

BES-116AC, 916AC, 1216AC

SERVICE MANUAL

BROTHER
EMBROIDERY
SYSTEMS

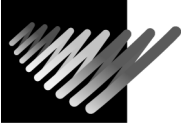

Please read this manual before making any adjustments.

SINGLE HEAD ELECTRONIC EMBROIDERY MACHINE

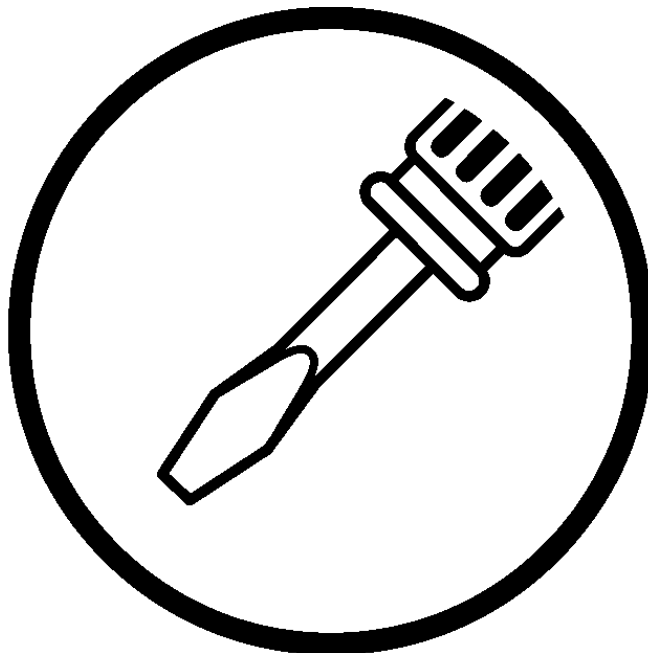

brother[®]

Thank you very much for buying a BROTHER sewing machine. Before using your new machine, please read the safety instructions below and the explanations given in the instruction manual.



With industrial sewing machines, it is normal to carry out work while positioned directly in front of moving parts such as the needle and thread take-up lever, and consequently there is always a danger of injury that can be caused by these parts. Follow the instructions from training personnel and instructions regarding safe and correct operation before operating the machine so that you will know how to use the machine correctly.

SAFETY INSTRUCTIONS

1. Safety indications and their meanings

This instruction manual and the indications and symbols that are used on the machine itself are provided in order to ensure safe operation of this machine and to prevent accidents and injury to yourself or other people. The meanings of these indications and symbols are given below.

Indications

 DANGER	The instructions which follow this term indicate situations where failure to follow the instructions will almost certainly result in death or severe injury.
 CAUTION	The instructions which follow this term indicate situations where failure to follow the instructions could cause injury when using the machine or physical damage to equipment and surroundings.

Symbols



----- This symbol (Δ) indicates something that you should be careful of. The picture inside the triangle indicates the nature of the caution that must be taken.
(For example, the symbol at left means "beware of injury".)



----- This symbol ($\textcircled{/}$) indicates something that you must not do.



----- This symbol (\bullet) indicates something that you must do. The picture inside the circle indicates the nature of the thing that must be done.
(For example, the symbol at left means "you must make the ground connection".)

2. Notes on safety

DANGER



Wait at least 5 minutes after turning off the power switch and disconnecting the power cord from the wall outlet before opening the face plate of the control box. Touching areas where high voltages are present can result in severe injury.

CAUTION

Environmental requirements



Use the sewing machine in an area which is free from sources of strong electrical noise such as high-frequency welders. Sources of strong electrical noise may cause problems with correct operation.



Any fluctuations in the power supply voltage should be within $\pm 10\%$ of the rated voltage for the machine. Voltage fluctuations which are greater than this may cause problems with correct operation.



The power supply capacity should be greater than the requirements for the sewing machine's electrical consumption. Insufficient power supply capacity may cause problems with correct operation.



The air supply should have a capacity greater than the machine air consumption. If air is not supplied sufficiently, a machine malfunction may occur.



The ambient temperature should be within the range of 5°C to 35°C during use. Temperatures which are lower or higher than this may cause problems with correct operation.



The relative humidity should be within the range of 45% to 85% during use, and no dew formation should occur in any devices. Excessively dry or humid environments and dew formation may cause problems with correct operation.



Avoid exposure to direct sunlight during use. Exposure to direct sunlight may cause problems with correct operation.



In the event of an electrical storm, turn off the power and disconnect the power cord from the wall outlet. Lightning may cause problems with correct operation.

Installation



Machine installation should only be carried out by a qualified technician.



Contact your Brother dealer or a qualified electrician for any electrical work that may need to be done.



The sewing machine weighs more than about 195 kg. The installation should be carried out by two or more people.



Do not connect the power cord until installation is complete, otherwise the machine may operate if the foot switch is depressed by mistake, which could result in injury.



Be sure to connect the ground. If the ground connection is not secure, you run the risk of receiving a serious electric shock.



When securing the cords, do not bend the cords excessively or fasten them too hard with staples, otherwise there is the danger that fire or electric shocks could occur.



Be sure to wear protective goggles and gloves when handling the lubricating oil and grease, so that they do not get into your eyes or onto your skin, otherwise inflammation can result. Furthermore, do not drink the oil or eat the grease under any circumstances, as they can cause vomiting and diarrhea. Keep the oil out of the reach of children.













Avoid setting up the sewing machine near sources of strong electrical noise such as high-frequency welding equipment. [If this precaution is not taken, incorrect machine operation may result.]





Secure the machine with the nuts when installing it so that it will not move by placing the leveling seat on the sound floor.

⚠ CAUTION







Sewing

	This sewing machine should only be used by operators who have received the necessary training in safe use beforehand.		Turn off the power switch at the following times, otherwise the machine may operate if the foot switch is depressed by mistake, which could result in injury. When threading the needle When replacing the bobbin and needle When not using the machine and when leaving the machine unattended
	Do not get on the table. Table may be damaged.		
	The sewing machine should not be used for any applications other than sewing.		Do not touch any of the pulse motor and sewing machine bed section during operation or for 30 minutes after operation. Otherwise burns may result
	Be sure to wear protective goggles when using the machine. If goggles are not worn, there is the danger that if a needle breaks, parts of the broken needle may enter your eyes and injury may result.		Secure the machine with the nuts when installing it so that it will not move by placing the leveling seat on the sound floor.
	Attach all safety devices before using the sewing machine. If the machine is used without these devices attached, injury may result.		If an error occurs in machine operation, or if abnormal noises or smells are noticed, immediately turn off the power switch. Then contact your nearest Brother dealer or a qualified technician.
	Do not touch any of the moving parts or press any objects against the machine while sewing, as this may result in personal injury or damage to the machine.		If the machine develops a problem, contact your nearest Brother dealer or a qualified technician.

Cleaning

	Turn off the power switch before starting any cleaning work, otherwise the machine may operate if the foot switch is depressed by mistake, which could result in injury.		Be sure to wear protective goggles and gloves when handling the lubricating oil and grease, so that they do not get into your eyes or onto your skin, otherwise inflammation can result. Furthermore, do not drink the oil or eat the grease under any circumstances, as they can cause vomiting and diarrhea. Keep the oil out of the reach of children.
---	--	---	---

Maintenance and inspection

	Maintenance and inspection of the sewing machine should only be carried out by a qualified technician.		If the power switch needs to be left on when carrying out some adjustment, be extremely careful to observe safety precautions.
	Ask your Brother dealer or a qualified electrician to carry out any maintenance and inspection of the electrical system.		Use only the proper replacement parts as specified by Brother.
	Turn off the power switch and disconnect the power cord from the wall outlet at the following times, otherwise the machine may operate if the foot switch is depressed by mistake, which could result in injury. <ul style="list-style-type: none"> - When carrying out inspection, adjustment and maintenance - When replacing consumable parts such as the rotary hook and knife 		If any safety devices have been removed, be absolutely sure to re-install them to their original positions and check that they operate correctly before using the machine.
			Any problems in machine operation which result from unauthorized modifications to the machine will not be covered by the warranty.

3. Warning labels

The following warning labels appear on the sewing machine. Please follow the instructions on the labels at all times when using the machine. If the labels have been removed or are difficult to read, please contact your nearest Brother dealer.

1 Safety devices: Thread take-up cover, Belt cover, etc.

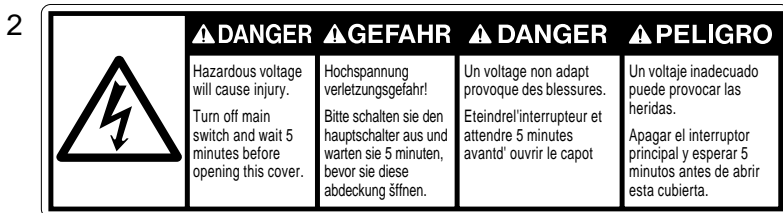
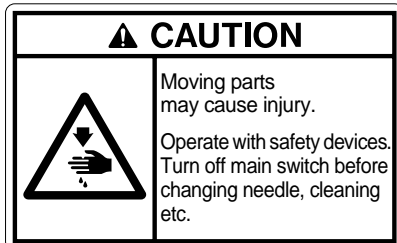

3  Never touch or push the thread take up during operation as it may result in injuries machine.

4  Never touch or push the needle bar during operation as it may result in injuries or damage to the sewing machine.

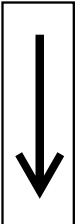
5  Direction of operation

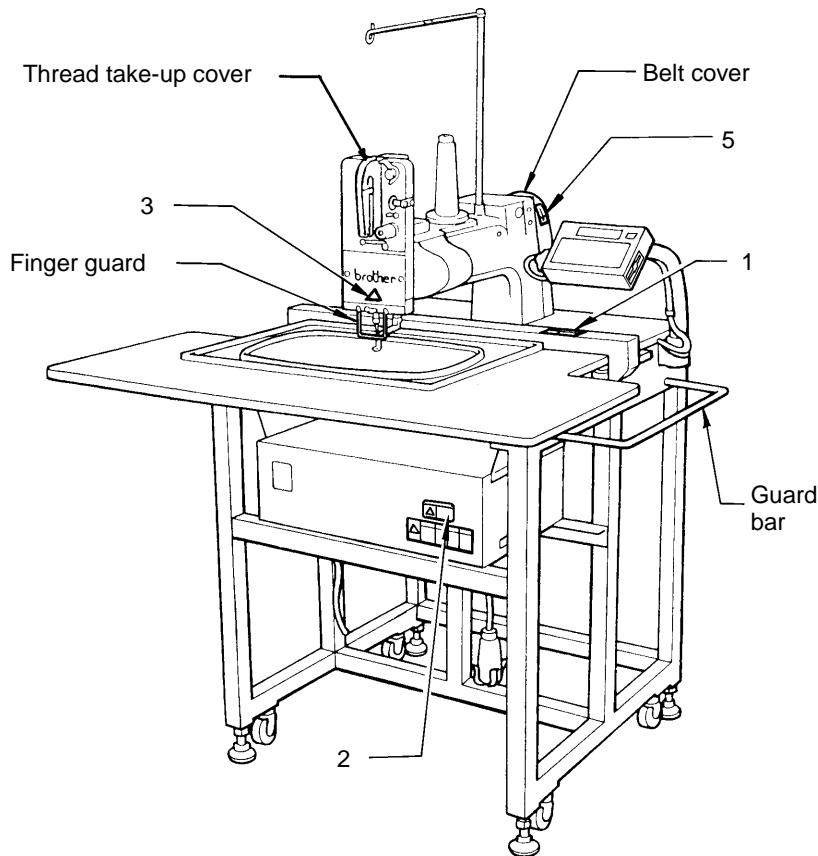

H0621

[BES-1216AC]

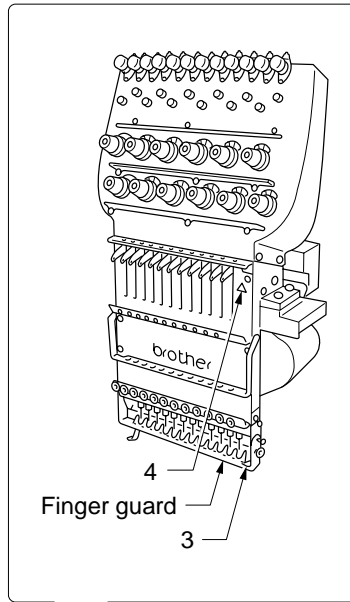

[BES-916AC]

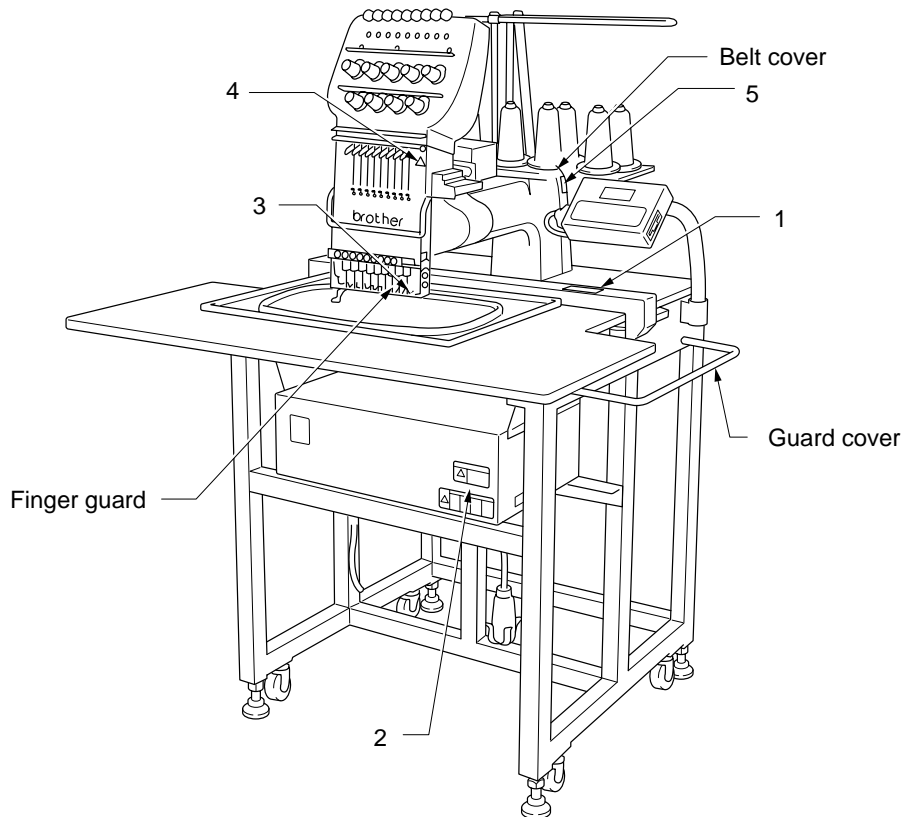

H0623

Contents

1. Part descriptions	1	3-10. Replacing and adjusting the parts related to the presser foot (BES-116AC, 916AC, 1216AC)	30
BES-116AC.....	1	3-10-1. Replacing the presser foot	30
BES-916AC, 1216AC	2	3-10-2. Replacing and adjusting the presser shaft when the needle bar case is attached.....	30
2. Mechanical descriptions.....	3	3-10-3. Adjusting the presser shaft when the needle bar case is attached.....	32
2-1. Upper shaft mechanism (BES-116AC, 916AC, 1216AC).....	3	3-10-4. Replacing the presser retracting lever.....	32
2-2. Lower shaft and rotary hook mechanism (BES-116AC, 916AC, 1216AC).....	4	3-10-5. Replacing the retracting solenoid lever	33
2-3. Thread trimmer mechanism (BES-116AC, 916AC, 1216AC).....	5	3-10-6. Adjusting the presser retracting lever and the retracting solenoid lever.....	33
2-4. Thread wiper mechanism (BES-916AC, 1216AC) .	6	3-10-7. Replacing the presser retracting solenoid	34
2-5. Needle bar case driving mechanism (BES-916AC, 1216AC)	7	3-10-8. Adjusting the presser retracting solenoid .	34
2-6. Picker mechanism (BES-116AC, 916AC, 1216AC).....	8	3-11. Replacing and adjusting the parts related to the needle bar flip-up mechanism (BES-916AC)....	35
2-7. Drive, (X) feed mechanism (BES-116AC, 916AC, 1216AC).....	9	3-11-1. Replacing the cam gear	35
2-8. Drive, (Y) feed mechanism (BES-116AC, 916AC, 1216AC).....	10	3-11-2. Assembly	36
2-9. Presser foot mechanism (BES-116AC, 916AC, 1216AC).....	11	Replacing and adjusting the parts related to the needle bar flip-up mechanism (BES-1216AC)	38
2-10. Cap frame device (optional).....	12	Replacing the cam gear	38
3. Parts replacement and adjustment.....	13	Assembly	40
3-1. Replacing and adjusting the machine head (BES-116AC, 916AC, 1216AC).....	13	4. Adjustment	43
3-2. Attaching X wire (BES-116AC, 916AC, 1216AC) .	15	4-1. Adjusting the needle bar height (BES-116AC, 916AC, 1216AC)	43
Removal	15	4-1-1. When using the bottom dead center gauge	45
Attachment.....	15	4-2. Adjusting the timing between the needle and the rotary hook [when the needle bar is raised 2mm] (BES-116AC, 916AC, 1216AC)	46
3-3. Attaching Y wire (BES-116AC, 916AC, 1216AC) .	17	4-3. Adjusting the presser foot height (BES-116AC, 916AC, 1216AC)	47
Remove Y wire L.....	17	4-4. Adjusting the spring.....	48
Attach Y wire L.....	17	4-5. Adjusting the picker (BES-116AC, 916AC, 1216AC)	49
Remove Y wire R.....	18	4-6. Adjusting the clearance between the rotary hook and the inner rotary hook stopper (BES-116AC, 916AC, 1216AC)	50
Attach Y wire R	18	4-7. Adjusting the movable knife and the fixed knife (BES-116AC, 916AC, 1216AC)	50
3-4. Adjusting the needle bar case position	19	4-8. Adjusting the thread wiper (BES-916AC, 1216AC).....	51
3-4-1. BES-116AC	19	4-9. Adjusting wire tension (BES-116AC, 916AC, 1216AC)	52
3-4-2. BES-916AC, 1216AC	20	4-9-1. X-feed wire.....	52
3-5. Replacing the thread take-up lever.....	21	4-9-2. Y-feed wire.....	53
3-5-1. BES-116AC.....	21	4-10. Adjusting the thread trimmer cam (BES-116AC, 916AC, 1216AC)	54
3-5-2. BES-916AC, 1216AC	22	4-11. Adjusting the thread sensor (BES-116AC)	55
3-6. Replacing the needle bar (BES-116AC, 916AC, 1216AC).....	24	4-12. Adjusting the wire of the cap frame device (BES-116AC, 916AC, 1216AC)	56
3-7. Replacing the jump bracket (BES-116AC, 916AC, 1216AC).....	25		
3-8. Replacing and adjusting the jump solenoid (BES-116AC, 96AC, 1216AC).....	26		
3-9. Replacing the synchronizer and the sensor circuit board (BES-116AC, 916AC, 1216AC)	28		

4-13. Replacing an adjusting the potentiometer assembly	56	8-3. Fuses.....	90
4-14. Adjusting the bobbin winder (BES-116AC, 916AC, 1216AC)	59	8-3-1. Position of fuses	90
4-14-1. Positioning the bobbin winder claw	59	8-3-2. Fuse type and capacity.....	90
4-14-2. Positioning the bobbin presser	60	8-3-3. Replacing fuse	91
5. Test Mode.....	61	8-4. About P-ROM (BES-116AC, 916AC, 1216AC)	92
5-1. Entering into the test mode	61	8-5. Connectors	93
5-2. Selecting the test mode menu.....	61	8-5-1. Min circuit board connectors.....	93
5-3. Function of the test mode.....	62	8-5-2. Power supply circuit board connectors	97
5-3-1. Needle bar moving test	62	8-5-3. Head PCB connectors	98
5-3-2. Carriage sensor test, stopper adjustment.	64	8-5-4. Panel PCB connectors.....	100
5-3-3. Encoder signal test.....	66	9. Error code list	102
5-3-4. Presser foot test	67	BES-116AC.....	102
5-3-5. Port, voltage check.....	68	BES-916AC, 1216AC	107
5-3-6. Solenoid test	69	10. Troubleshooting flowchart.....	112
5-3-7. Main shaft motor rotation test.....	70	10-1. Troubleshooting flowchart when the power is on	112
5-3-8. Detailed version of CPU in the machine...	70	10-2. Troubleshooting flowchart in thread trimming operation	114
5-4. Adjusting the rotary encoder and sensor PCB	71	10-3. Troubleshooting flowchart in sewing operation (1).....	116
5-4-1. Adjusting the machine stop position signal	71	10-4. Troubleshooting flowchart in sewing operation (2).....	118
5-4-2. Adjusting the synchronizing signal	72	10-5. Troubleshooting flowchart in data entry operation	120
5-5. Adjusting home position using home position plate	73	10-6. Troubleshooting flowchart of control panel display	122
5-6. Adjusting the overtravel sensor and flat hoop stopper using the home position plate	75	11. Voltage check	124
6. Upgrading version of machine program	76	11-1. Input voltage from transformer.....	124
6-1. Downloading the file	76	11-2. Output voltage to each board.....	125
6-2. Crating the installation disk	76	11-3. Tap voltages on the transformer.....	126
7. Lubrication.....	79	11-3-1. Tap voltage layout on the terminal block	126
7-1. Machine head.....	79	11-3-2. Voltage values	126
7-2. Feed guide mechanism (BES-116AC, 916AC, 1216AC)	81	12 Trouble shooting	127
7-3. Cleaning	82	Mechanical Section.....	127
8. Electric components	83	Electrical Section	131
8-1. Circuit board locations.....	83	Circuit block diagram	139
8-2. Replacing circuit boards	84		
8-2-1. Main circuit board.....	84		
8-2-2. Machine motor circuit board	85		
8-2-3. Replacing the power supply circuit board.....	86		
8-2-4. Replacing the panel PCB	87		
8-2-5. Replacing the control panel.....	88		
8-2-6. Replacing the TR breakage sensor PCB..	89		

1. Part descriptions

BES-116AC

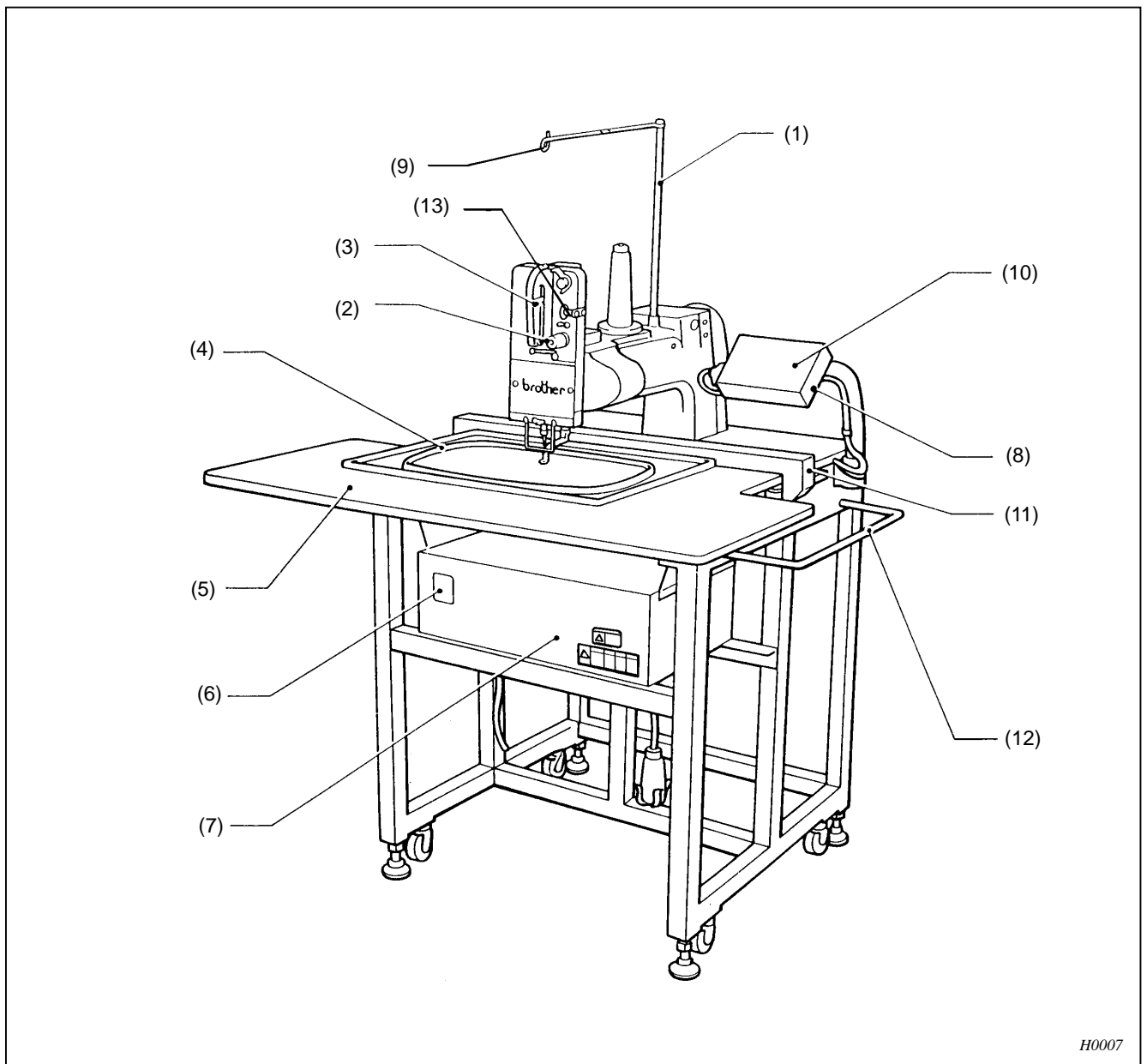

H0007

- | | | | |
|-----------------------------------|-------------------------|--------------------|---------------------|
| (1) Thread guide spool shaft | (2) Thread tension dial | (3) Thread take up | (4) Embroidery hoop |
| (5) Table | (6) Power switch | (7) Control box | (8) Disk drive |
| (9) Thread guide | (10) Control panel | (11) Carriages | (12) Guard bar |
| (13) Thread trimmer detect pulley | | | |

BES-916AC, 1216AC

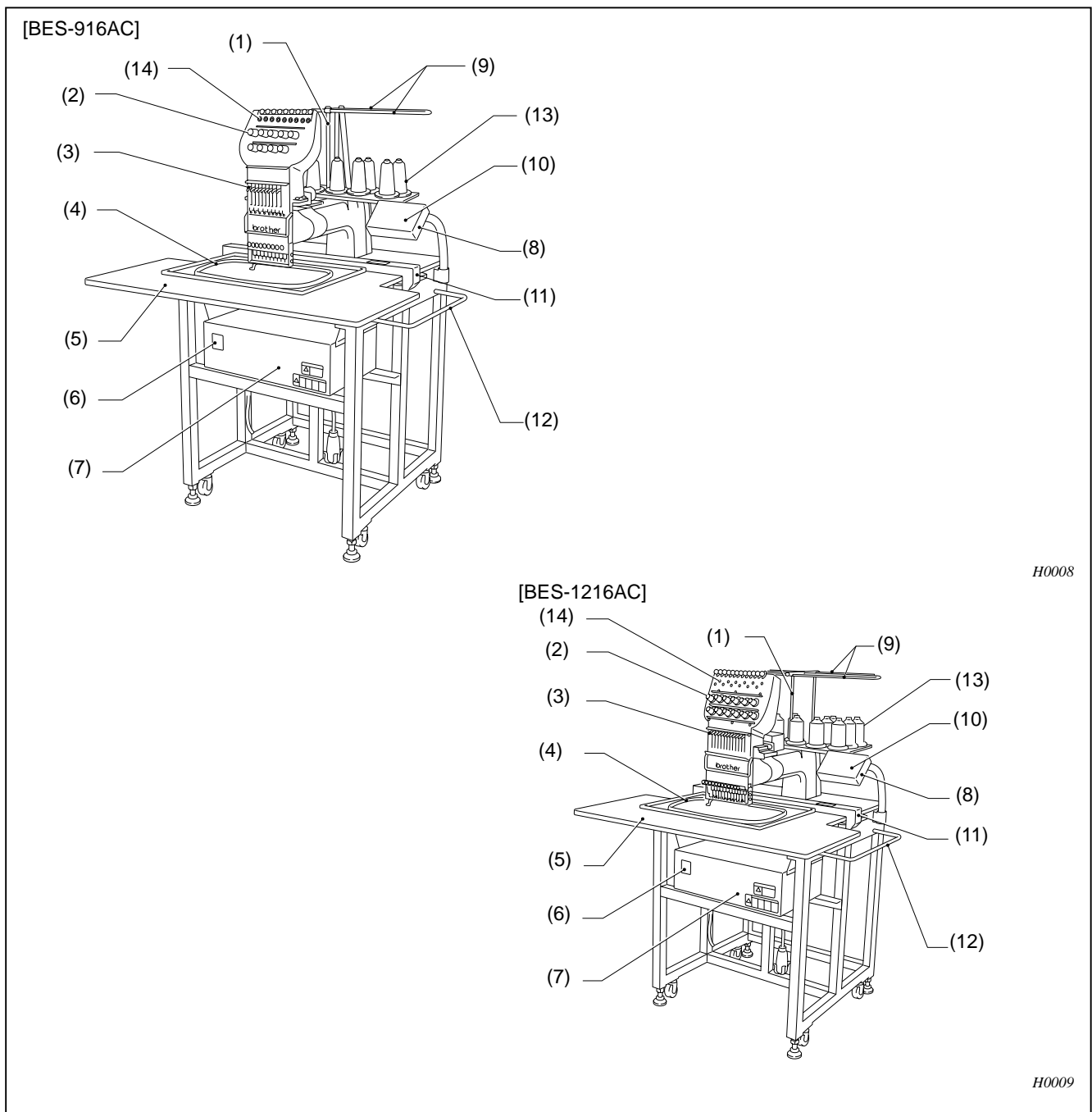

- | | | | |
|------------------------------|-----------------------------|--------------------|---------------------|
| (1) Thread guide spool shaft | (2) Thread tension dial | (3) Thread take up | (4) Embroidery hoop |
| (5) Table | (6) Power switch | (7) Control box | (8) Disk drive |
| (9) Thread guide | (10) Control panel | (11) Carriage | (12) Guard bar |
| (13) Cotton stand L | (14) Thread breakage sensor | | |

2. Mechanical descriptions

2-1. Upper shaft mechanism (BES-116AC, 916AC, 1216AC)

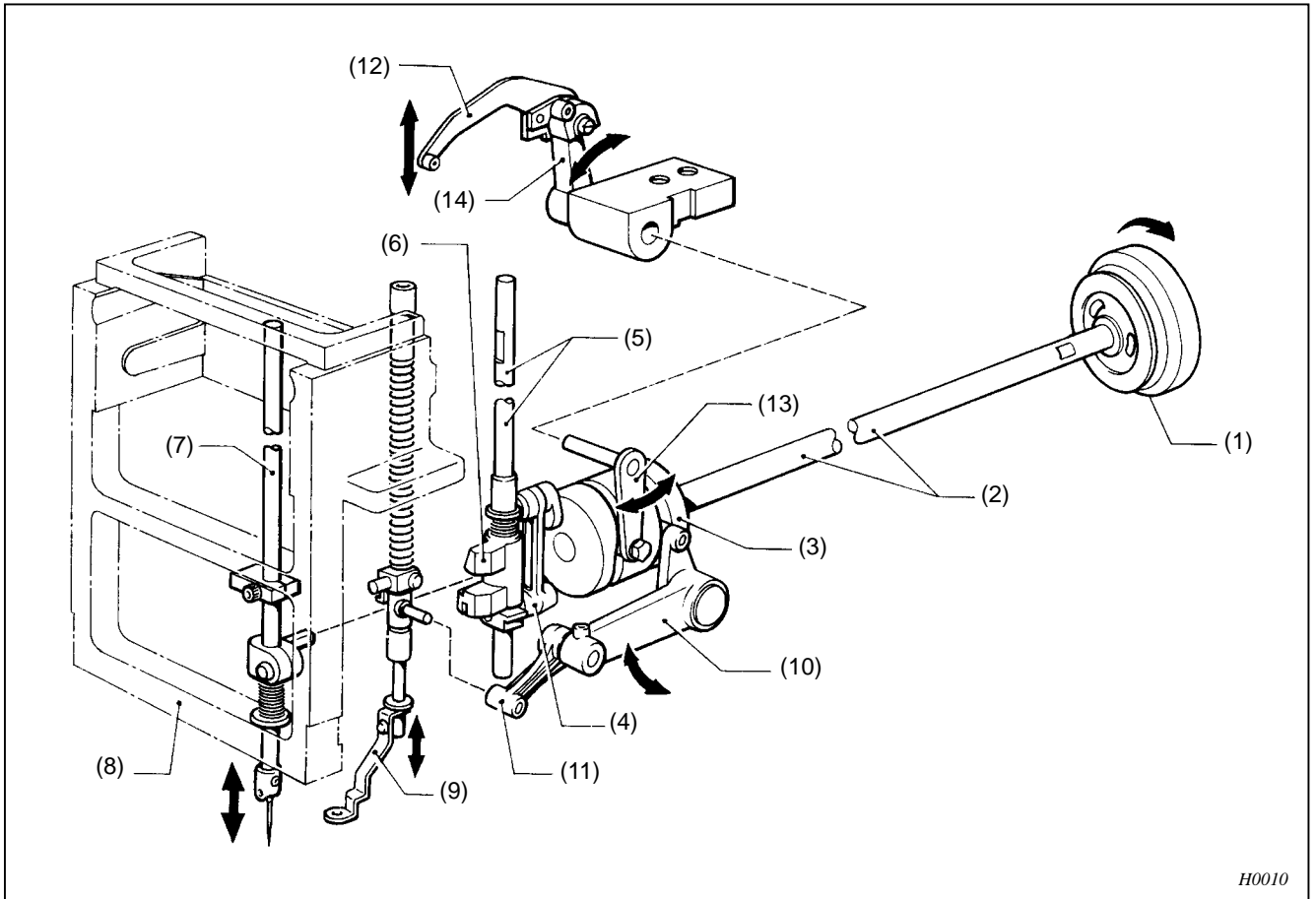

1. When the upper shaft pulley (1) is turned in the direction of the arrow, the motion is transmitted to the upper shaft (2), and the thread take-up cam (3) rotates.
2. The motion is transmitted to the needle bar crank rod (4) connected to the thread take-up cam (3).
3. The jump bracket (6) connected to the needle bar crank rod (4) moves the needle bar (7) via the base needle bar (5).
4. The needle bar (7) is guided by the needle bar case (8).
5. When the thread take-up cam (3) is turned, the presser driving lever (10) is moved back and forth, and the presser foot (9) is moved up and down via the presser differential link (11).
6. When the thread take-up cam (3) is turned, the thread take-up lever (12) is rocked via the thread take-up driving lever (13) and the thread take-up coupled driving lever (14).

2-2. Lower shaft and rotary hook mechanism (BES-116AC, 916AC, 1216AC)

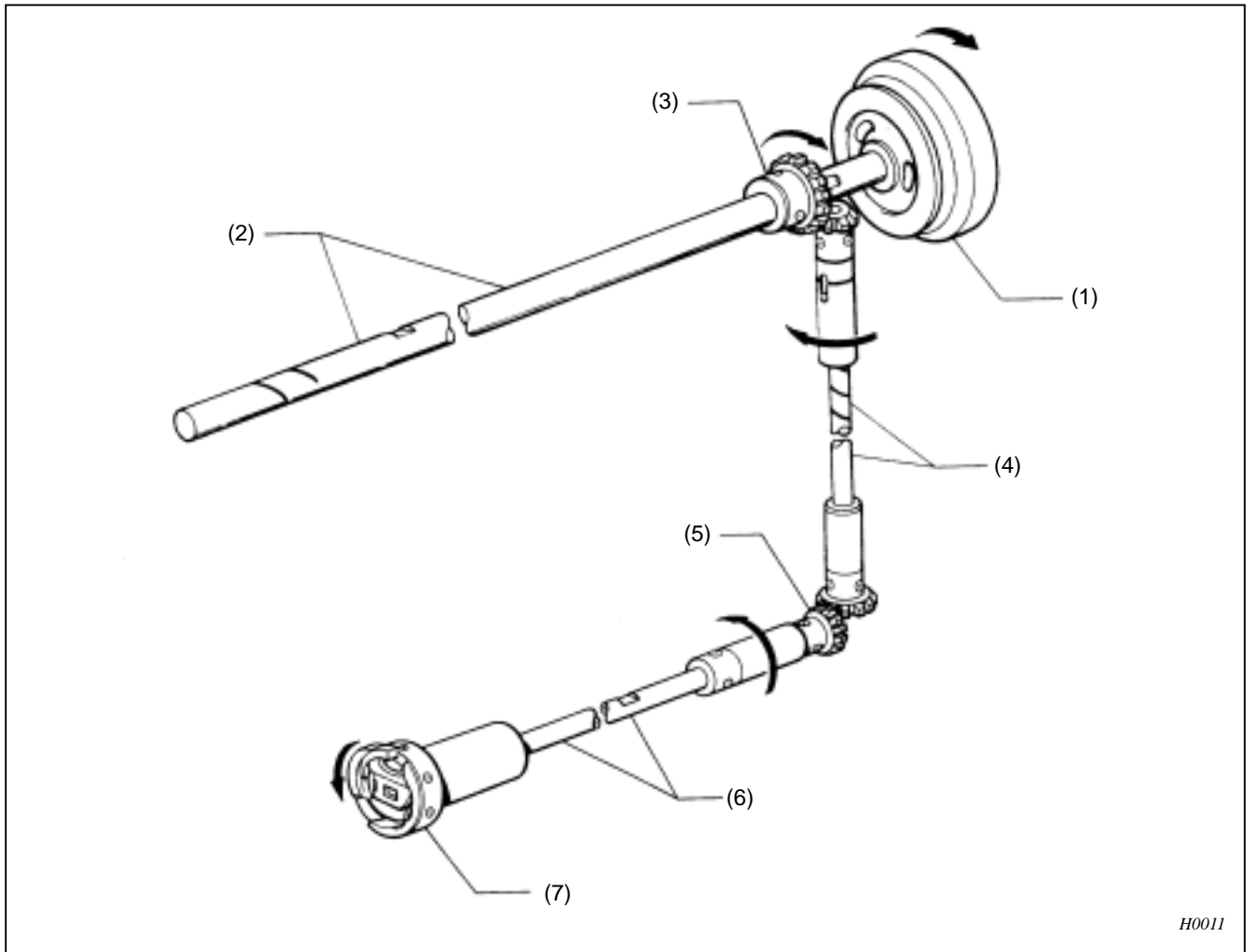

1. When the upper shaft pulley (1) rotates in the direction of the arrow, the motion is transmitted to bevel gear U (3) through the upper shaft (2).
 2. Bevel gear U (3) transmits the motion to bevel gear D (5) through the vertical shaft (4).
 3. Bevel gear D (5) transmits the motion to the attached lower shaft (6). Then the rotary hook (7), attached to the lower shaft (6), rotates in the direction of the arrow.
- * For BES-116AC, 916AC, 1216AC, the rotary hook makes two revolutions for each revolution made by the pulley.

2-3. Thread trimmer mechanism (BES-116AC, 916AC, 1216AC)

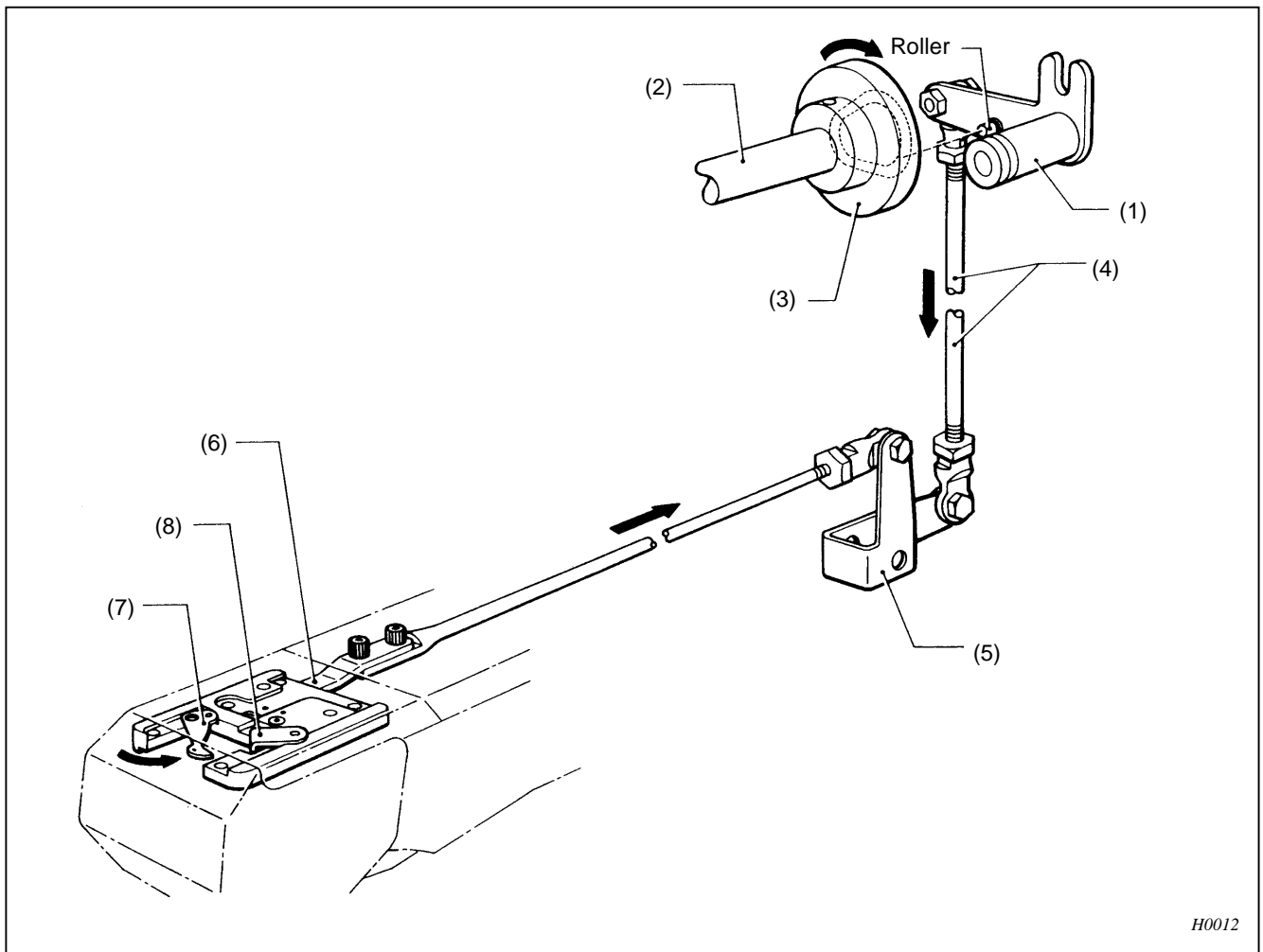

H0012

1. Upon making the final stitch, the roller of the thread trimmer diving lever (1) moves into the groove of the thread trimmer cam (3) on the upper shaft (2).
2. When the thread trimmer cam (3) rotates, the motion is transmitted to the thread trimmer connection rod (6) via the thread trimmer rod (4) and the thread trimmer lever (5).
3. The movable knife (7) and the fixed knife (8) engage each other to trim the thread.

2-4. Thread wiper mechanism (BES-916AC, 1216AC)

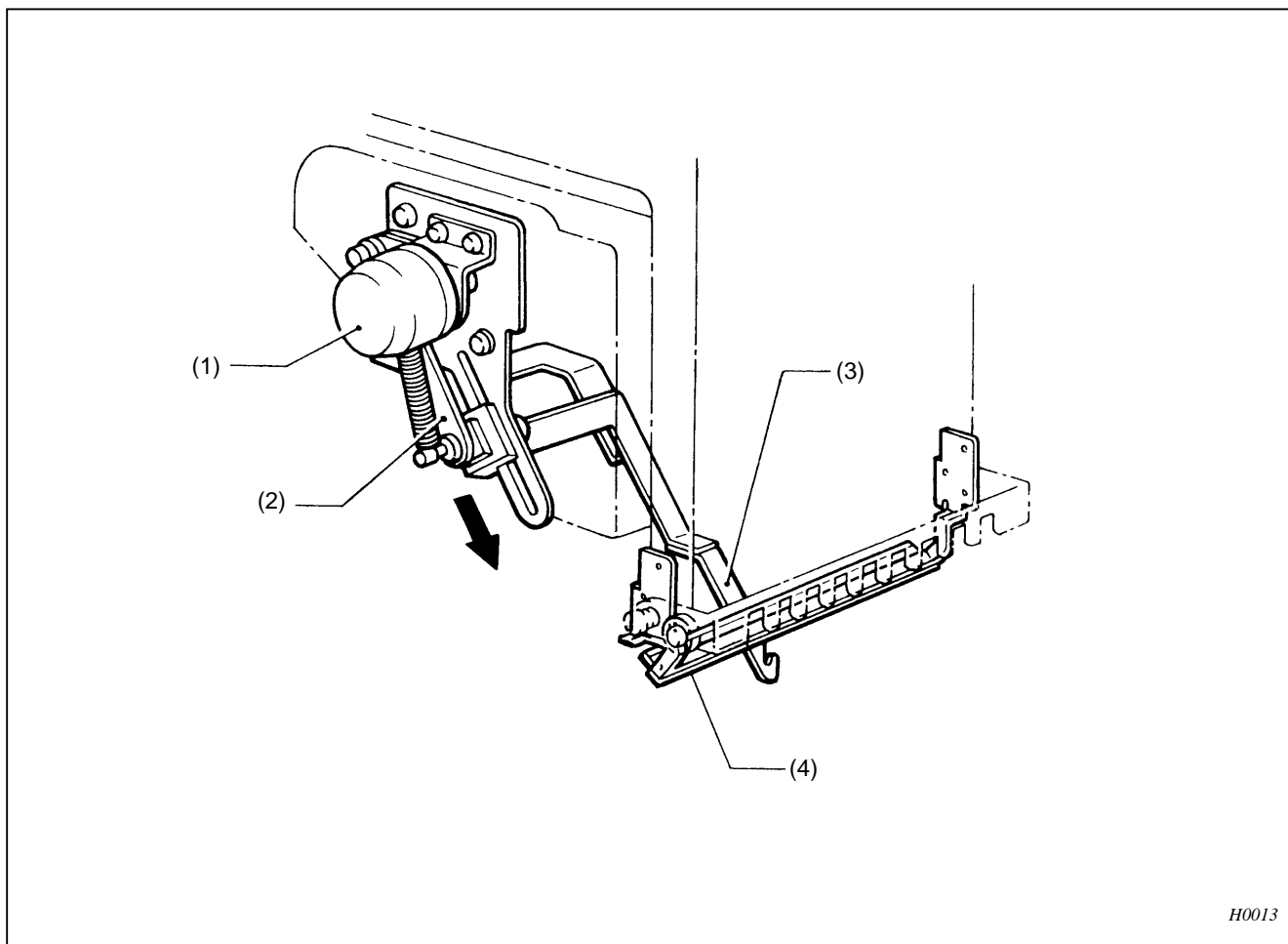

1. After sewing is finished, the wiper solenoid (1) moves the plate (2) in the direction of the arrow.
2. The upper thread guard hook (3) attached to the plate (2) brings the trimmed thread to the thread presser base (4). The thread presser base (4) secures the trimmed thread.

2-5. Needle bar case driving mechanism (BES-916AC, 1216AC)

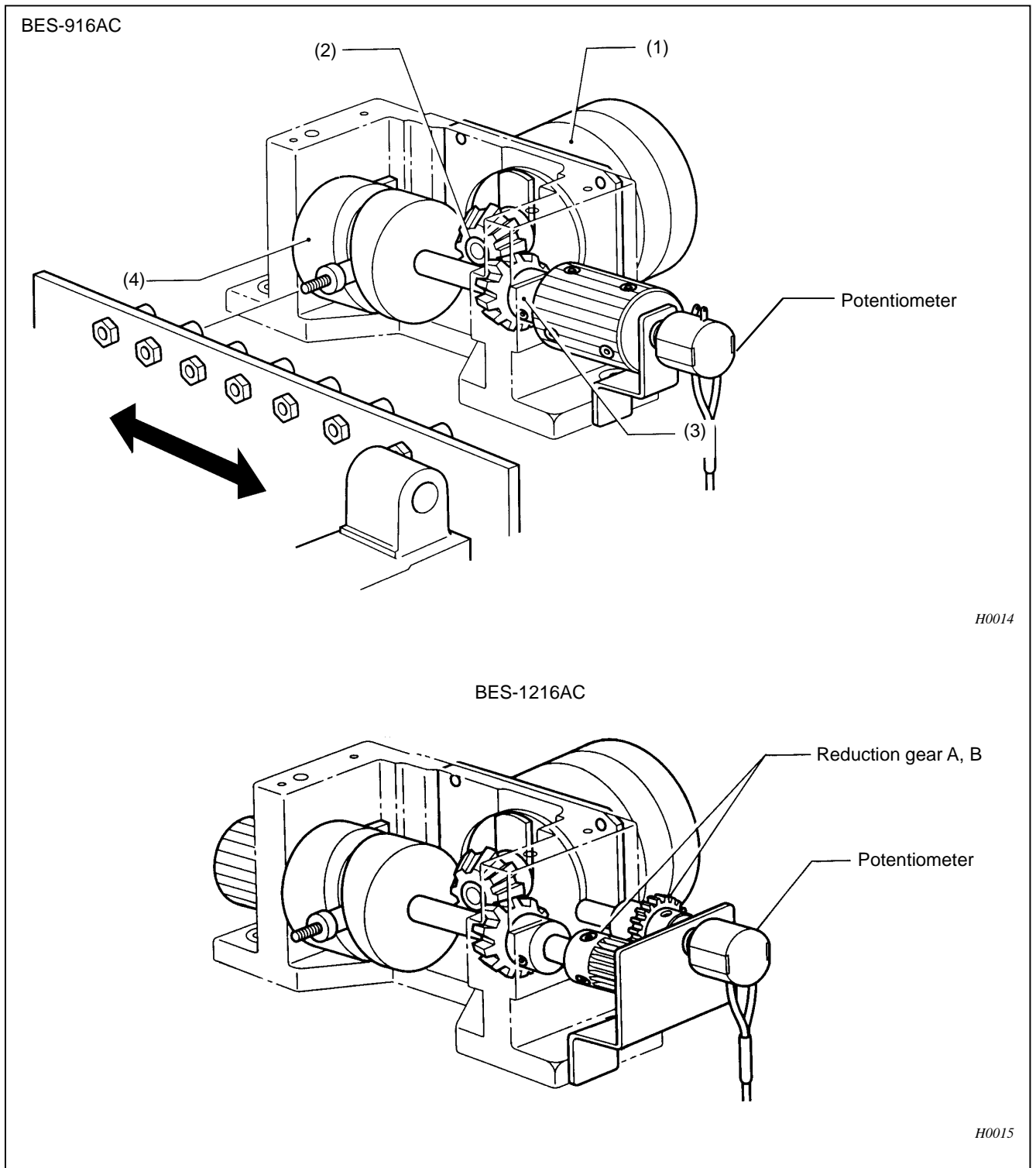

1. Stepping motor (1) drive the change cam (4) through cam gears A (2) and B (3).
2. The roller in the groove of change cam (4) drive the needle bar case in lateral direction.
3. Potentiometer feed back the position of needle bar case.

2-6. Picker mechanism (BES-116AC, 916AC, 1216AC)

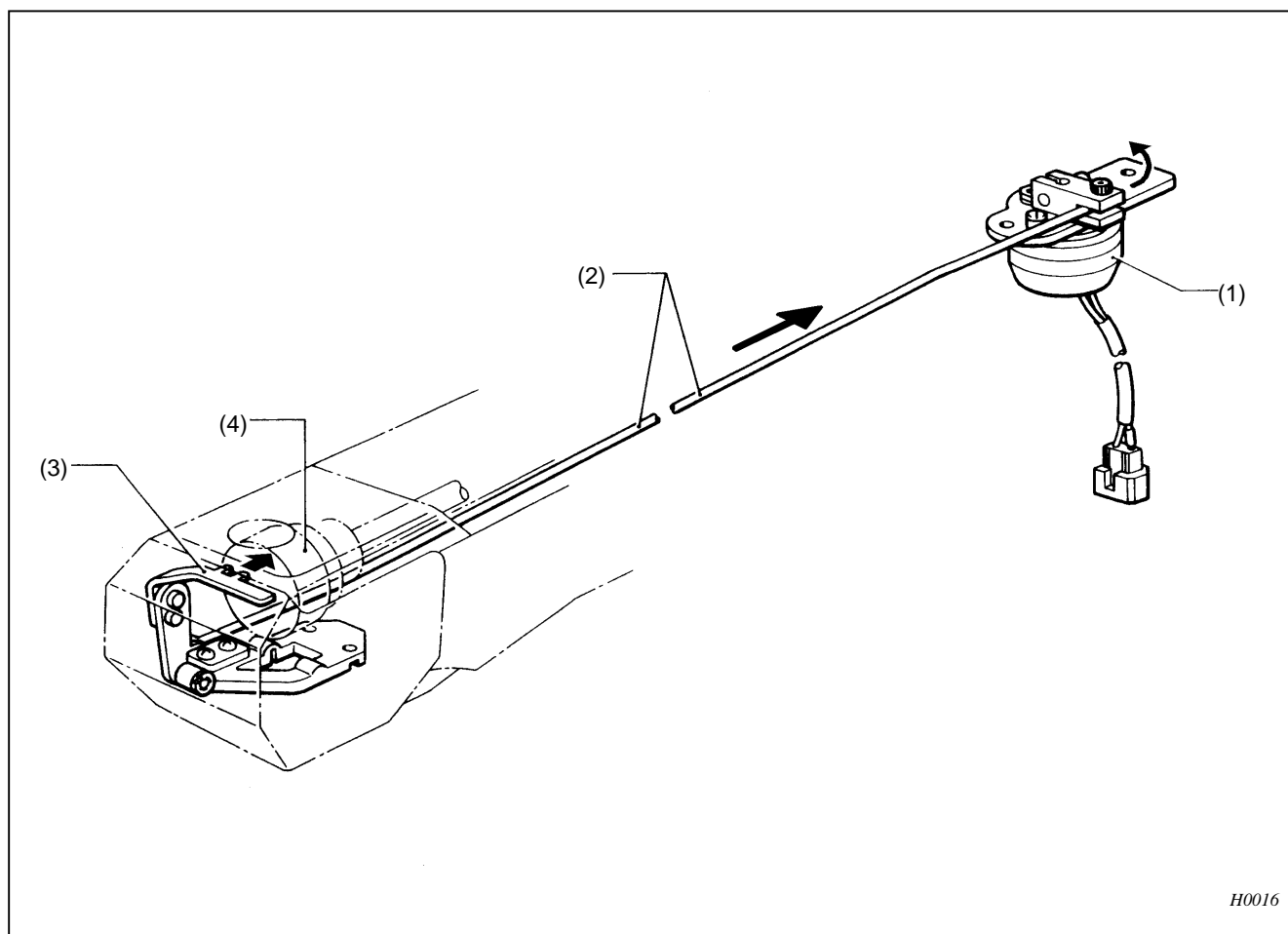

H0016

1. Rotary solenoid (1) pull the wire (2) so that the fork of picker lever (3) goes into the hook (4).
2. The fork of picker lever (3) catch the upper thread at the beginning of sewing to remain the end of thread underneath the fabric.
3. Also perform at the end of sewing to control thread tail length.

2-7. Drive, (X) feed mechanism (BES-116AC, 916AC, 1216AC)

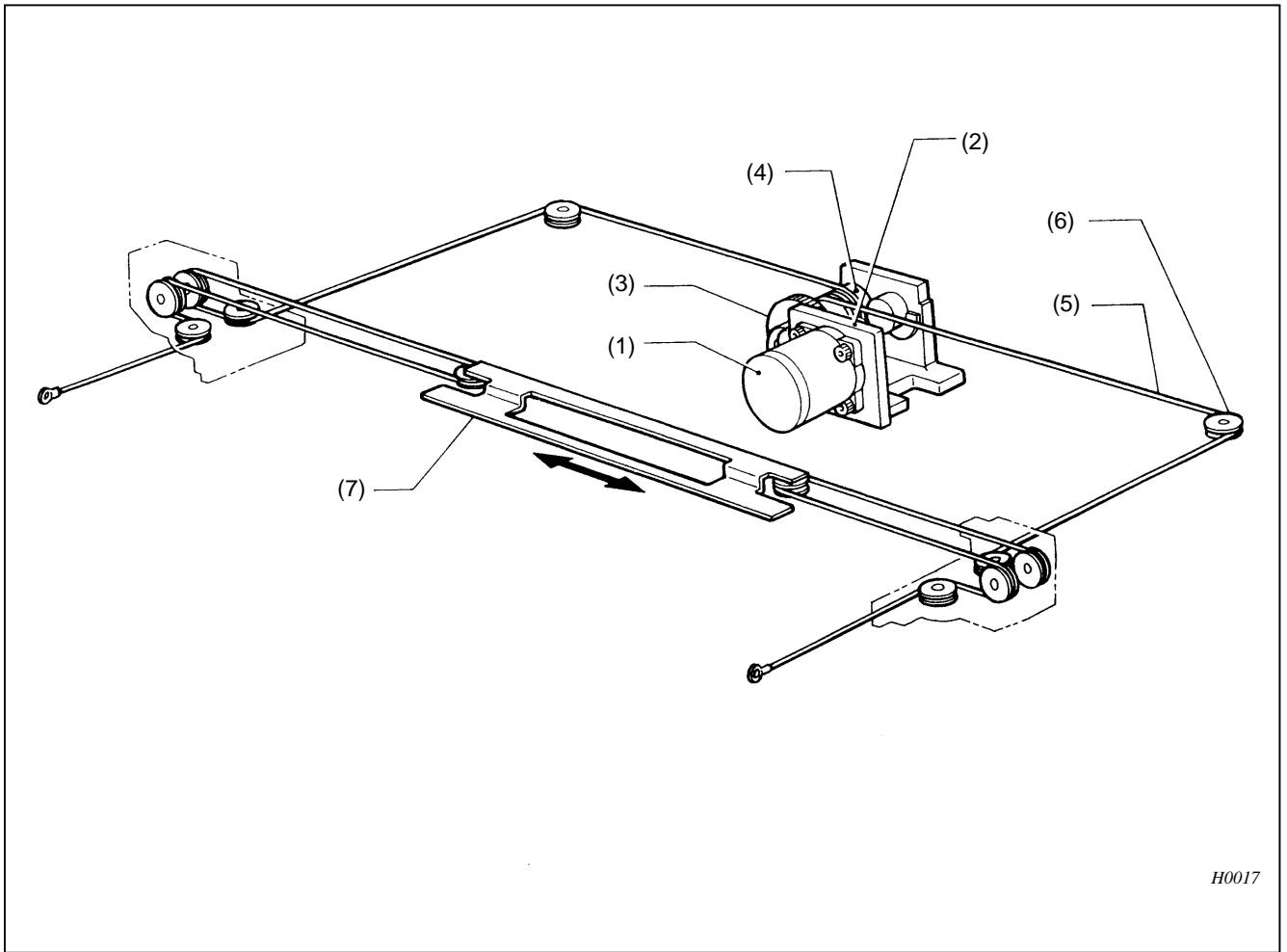

1. Pinion gear B (2) attached to the X-pulse motor (1) rotates, then transmits the rotation to idle gear A (3).
2. The wire drum X (4) driven by idle gear A (3) reel in the X wire (5) in either left or right direction.
3. X wire (5) drive the carriage (7) via pulley (6) in lateral direction.

2-8. Drive, (Y) feed mechanism (BES-116AC, 916AC, 1216AC)

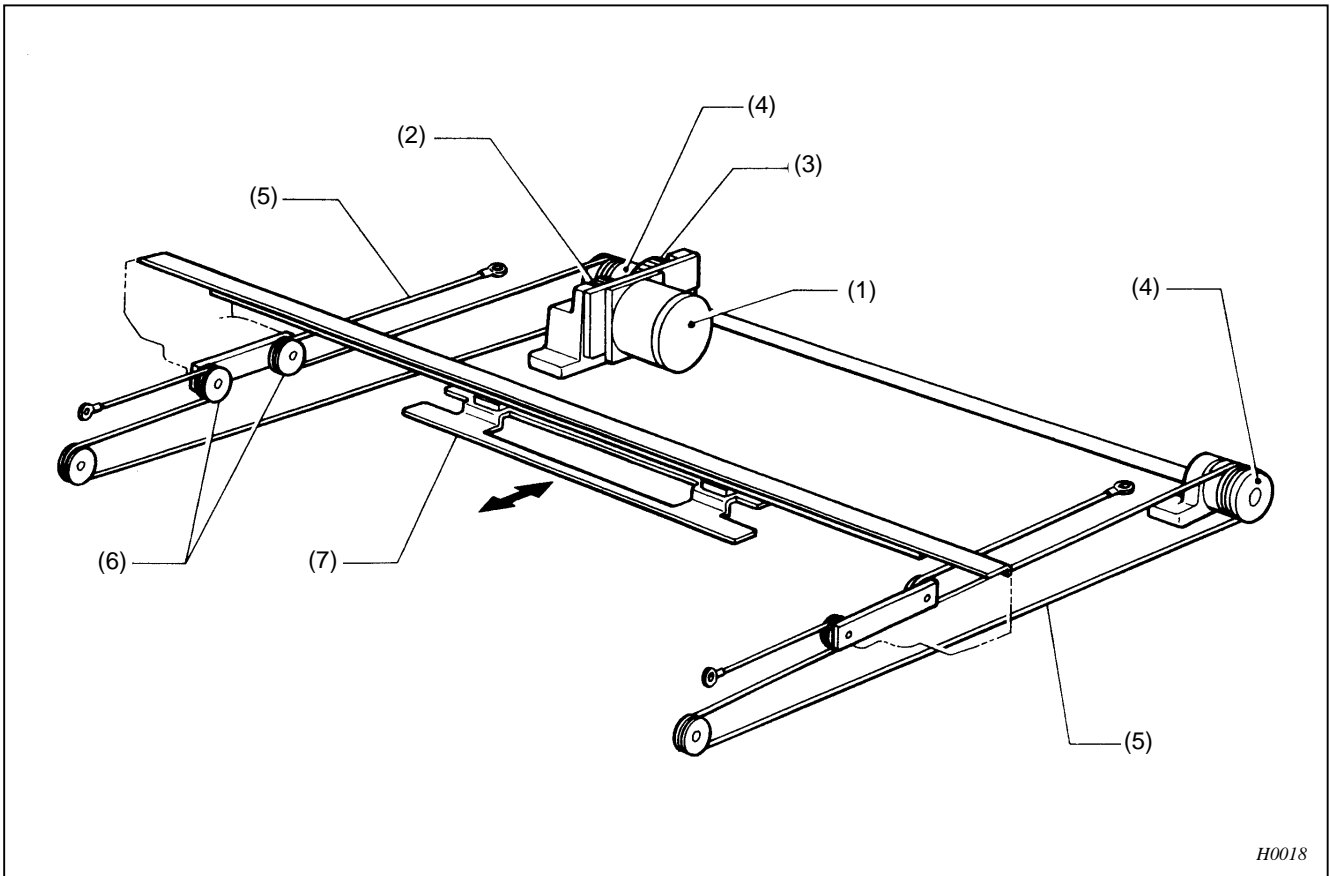

1. Pinion gear B (2) of the Y-pulse motor (1) rotates, then transmits the rotation to idle gear A (3).
2. Two wire drums (4) driven by idle gear A (3) reel in Y wires (5) on the left and right side.
3. Y wire (5) drive the carriage (7) via pulley (6) in vertical direction.

2-9. Presser foot mechanism (BES-116AC, 916AC, 1216AC)

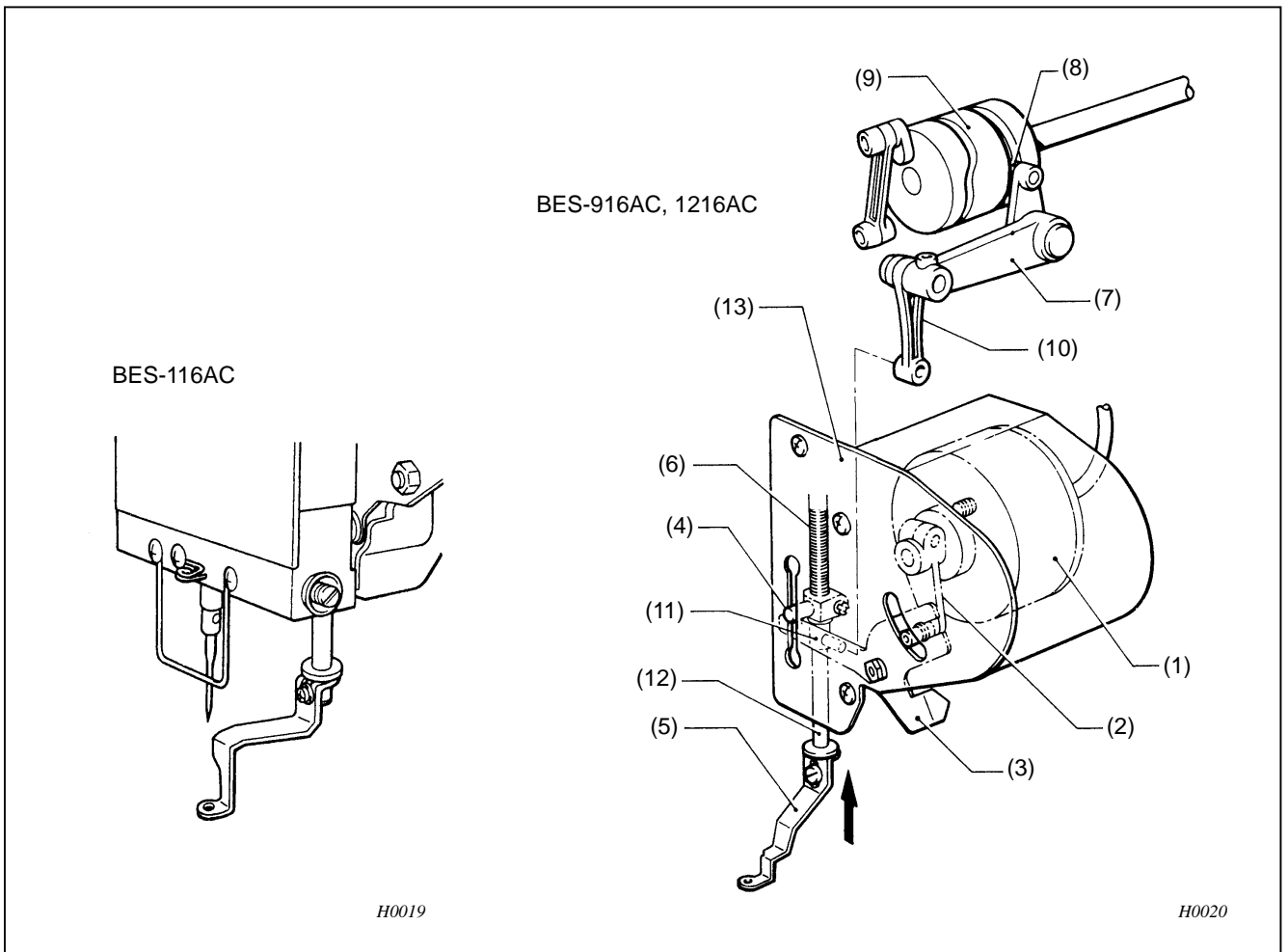

1. When the power is turned on, the presser retracting solenoid (1) rotate the retracting solenoid lever (2) anticlockwise.
2. The presser retracting lever (3) moves the presser shaft crank (4) and the presser foot (5) upward.
3. When sewing is started, the presser retracting solenoid (1) turns off, the presser foot (5) position is lowered by the spring (6) before the pulley rotates.
4. The roller (8) of the presser driving lever (7) transmits the motion of the thread take-up cam (9) to the presser operating link (10) via the presser driving lever (7).
5. The presser operating base (11) set in the presser operating link (10) and the presser shaft crank (4) fixed to the presser shaft (12) are moving together by the pressure from spring (6). They move the presser foot (5) up and down along the groove of the presser guide plate (13).
6. When sewing is finished, the presser retracting solenoid (1) raises the presser foot (5).

(MEMO) While the power is turned off, the presser foot (5) can be raised manually by pressing the presser retracting lever (3).



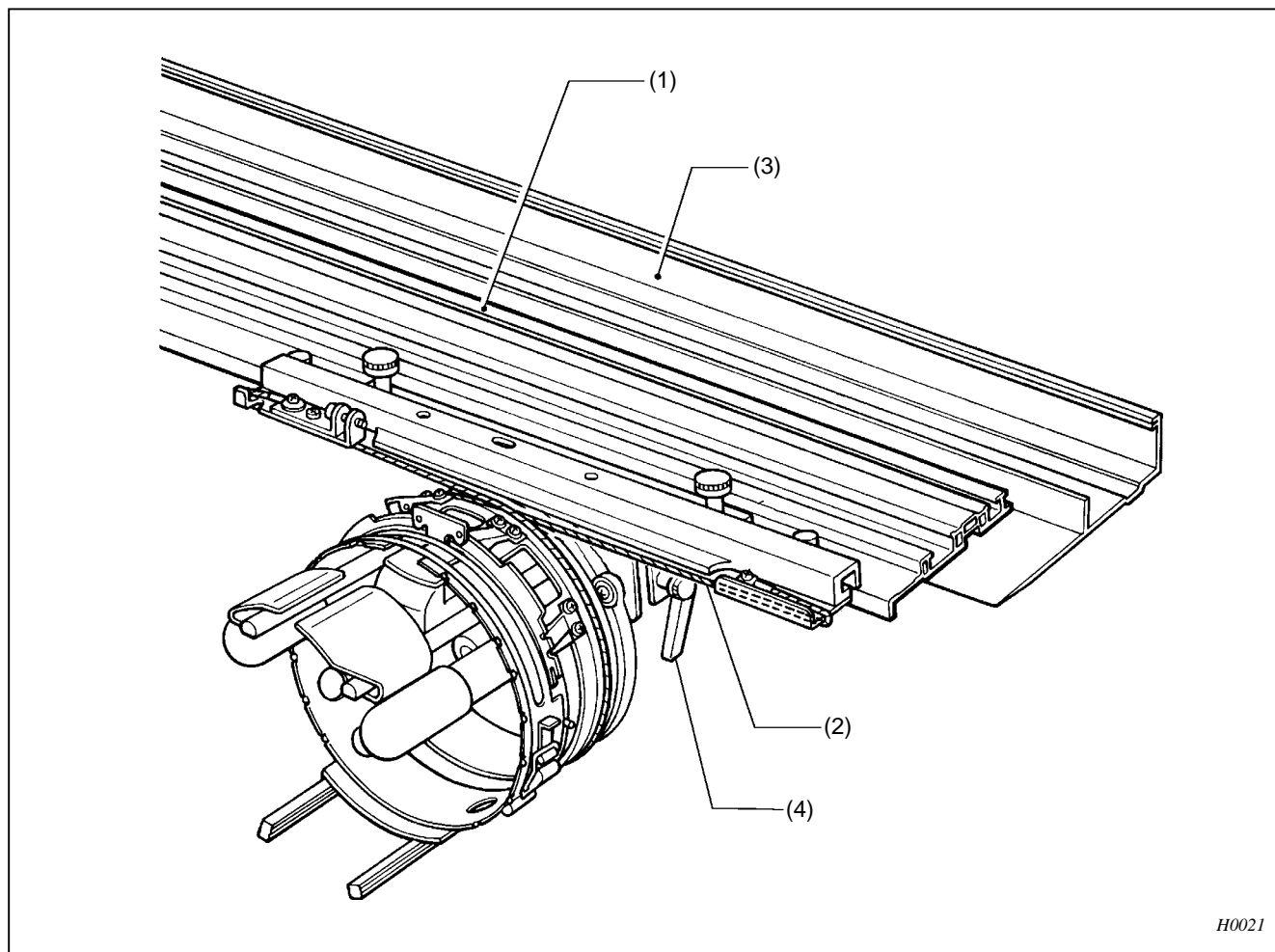



2-10. Cap frame device (optional)



H0021

1. The wire (2) fixed on X-carriage (1) drive the cap frame driver in rotation direction.
2. Motion in the Y direction is transmitted by driving arm (4) fixed to the Y-shaft driving rail (3).

3. Parts replacement and adjustment

! CAUTION	
<p> This sewing machine should only be used by operators who have received the necessary training in safe use beforehand.</p> <p> The sewing machine weighs more than 195kg. The installation should be carried out by two or more people.</p> <p> Turn off the power switch and disconnect the power cord from the wall outlet at the following times, otherwise the machine may operate if the start switch is pressed by mistake, which could result in injury.</p> <ul style="list-style-type: none"> - When carrying out inspection, adjustment and maintenance - When replacing consumable parts such as the rotary hook and knife 	<p> If the power switch needs to be left on when carrying out some adjustment, be extremely careful to observe all safety precautions.</p> <p> Use only the proper replacement parts as specified by Brother.</p> <p> If any safety devices have been removed, be absolutely sure to re-install them to their original positions and check that they operate correctly before using the machine.</p> <p> Any problems in machine operation which result from unauthorized modifications to the machine will not be covered by the warranty.</p>

3-1. Replacing and adjusting the machine head (BES-116AC, 916AC, 1216AC)

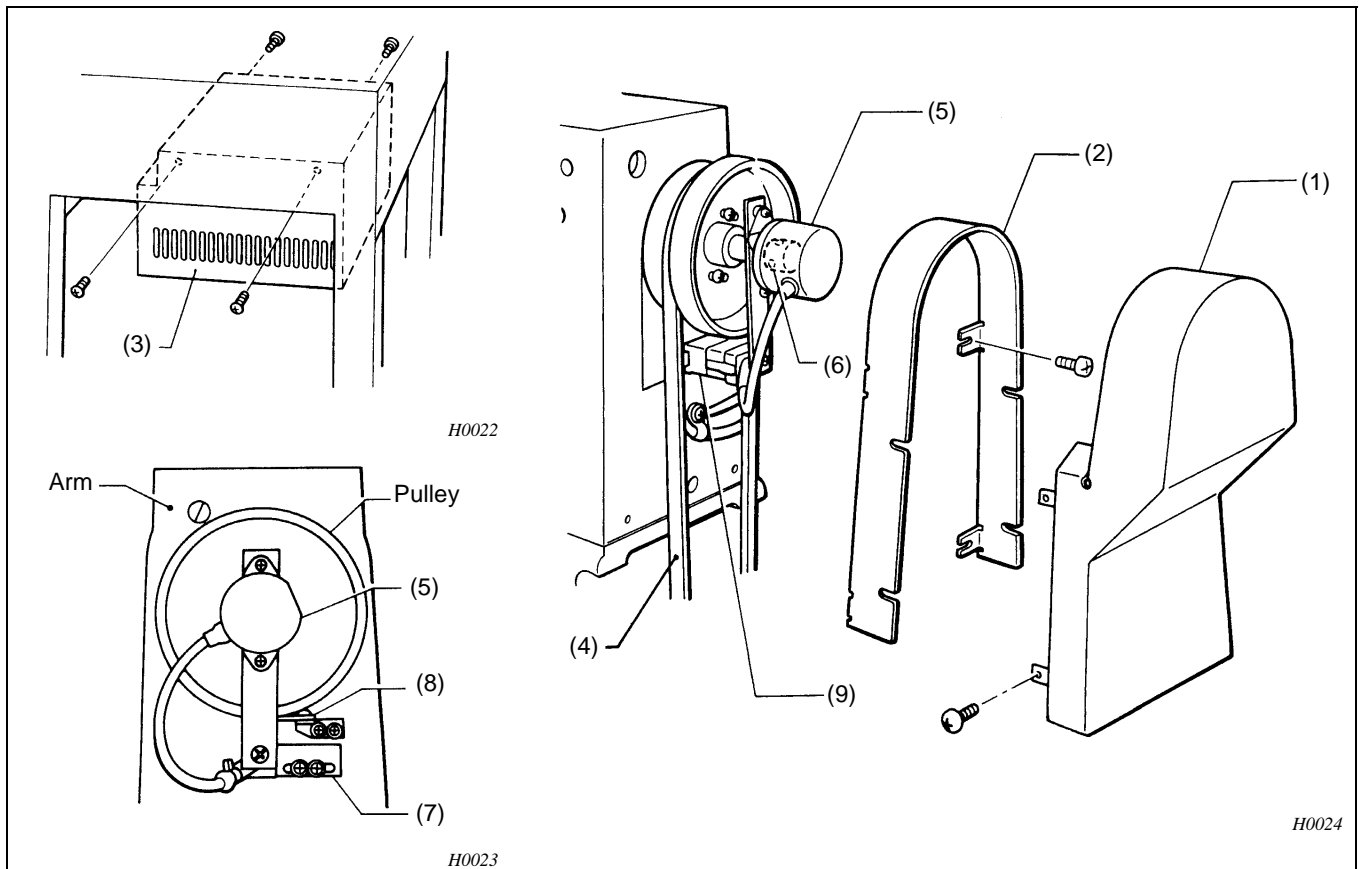

(NOTE) Be sure to remove all connectors attached to the machine head except for those for the feed mechanism.

1. Remove screws and belt cover B (1) and A (2).
2. Remove screws and the motor cover (3) attached to the bottom of the table leg.
3. Remove V belt (4).
4. Loosen two screws of rotary encoder (5) on rotary shaft (6), then remove screws and the encoder together with the encoder set plate (7) from the arm.
5. Remove screws from the arm. Remove the sensor circuit board (8) and the cord holder (9).

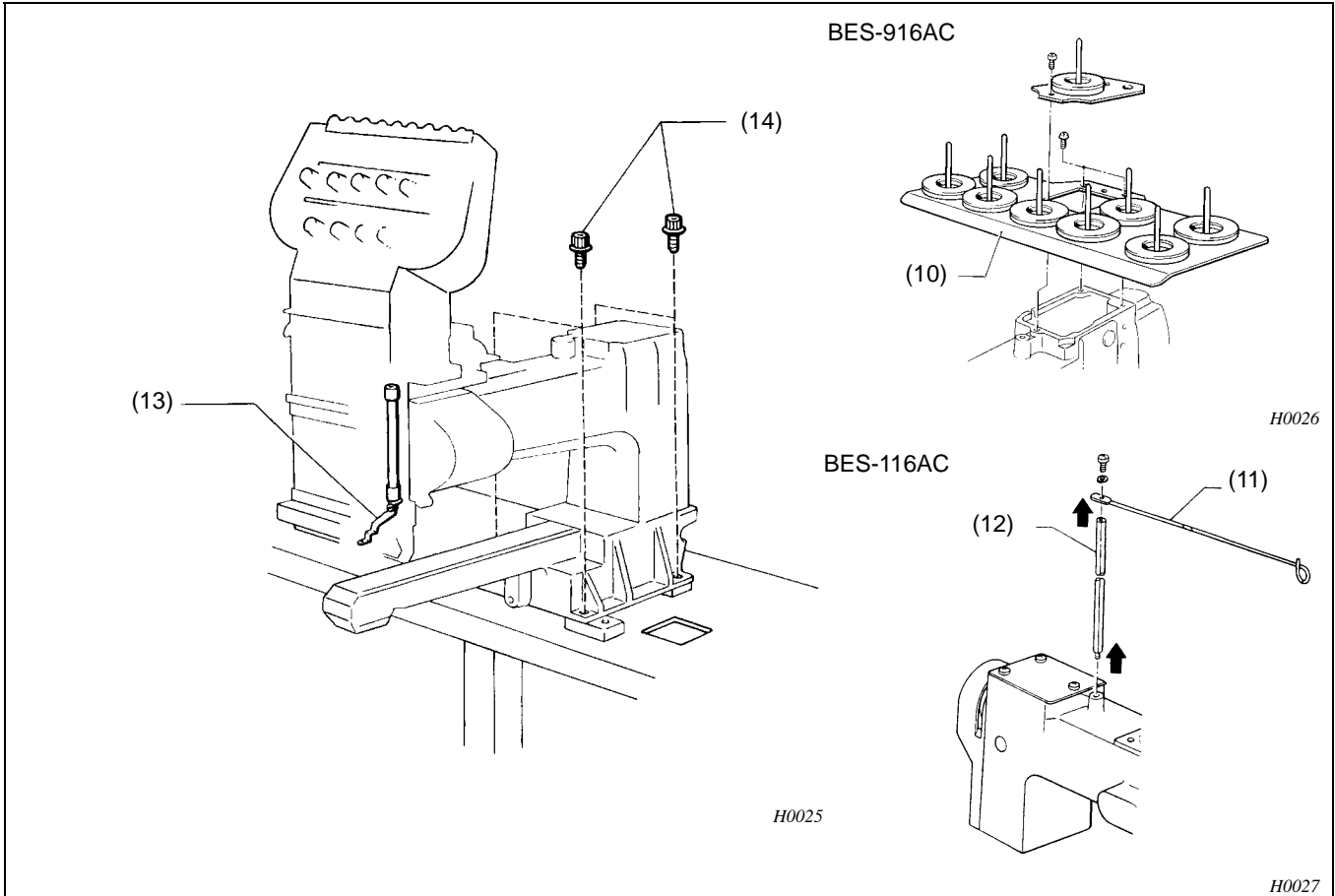

6. Remove screw and the cotton stand (10) from the machine head.
7. Remove the screw and the thread guide (11). Turn the thread guide bar (12) to remove it from the machine head. (BES-116AC)
8. Remove the presser foot (13). (Leave the feed mechanism position at all the way to the front.)
9. Remove four bolts (14) from the machine head. (Mark the position of the machine head on the steel frame so that it can be easily put back afterward.)
10. Remove the machine head from the rear of the steel frame.

(NOTE) Two or more persons are required to remove machine head because it weighs 50kg.

* After replacing the machine head with a new one, reverse the above procedure for assembly.

3-2. Attaching X wire (BES-116AC, 916AC, 1216AC)

(NOTE) Be careful not to scratch the wire as it is coated with resin and a scratch may decrease its durability.

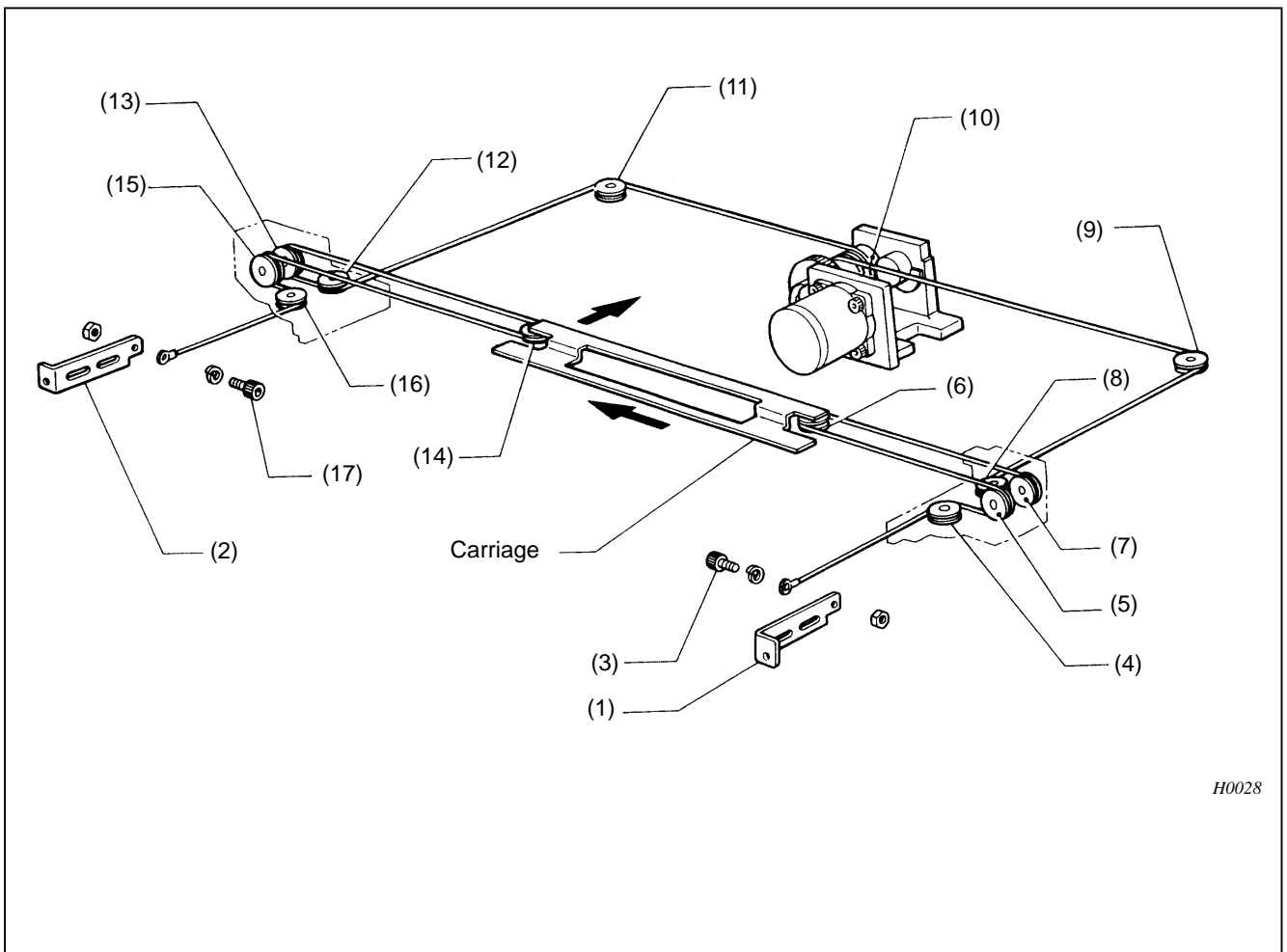

Removal

Remove bolts of hook RX (1) and hook LX (2), and remove the wire from the pulleys.

Attachment

1. Position the carriage at left backcorner of the machine and secure it not to move, making sure it does not move.
2. Attach the wire end (the end closer to the ball) to hook RK (1) with bolt (3).
3. Put through the wire around pulley (4) from the left side, then under pulley (5). Then put through it behind pulley (6) from the left side, and over pulley (7). Then, put through the wire around pulley (8) from the left, and finally wind it around pulley (9) from the right.
4. After winding the wire around pulley (9), apply some slack to the wire.

-
5. Put the ball on the wire into the hole of wire drum X (10).
Fit the wire completely into the groove, then wind the wire seven times around the wire drum.
(NOTE) The wire should be fed from the inner side when wounding around wire drum (X) (10).
 6. Feed the wire around the back of pulley (11), then around pulley (12) from the left.
Wind the wire onto pulley (13) from below, then around pulley (14) from the left.
Wind the wire over pulley (15) from above, then around pulley (16) from the left.
 7. Attach the wire to hook (LX) (2) with bolt (17).
 - * Exercise care to avoid destroying the resin layer that coats the wire.
The damaged layer may cause the wire to reduce durability.

3-3. Attaching Y wire (BES-116AC, 916AC, 1216AC)

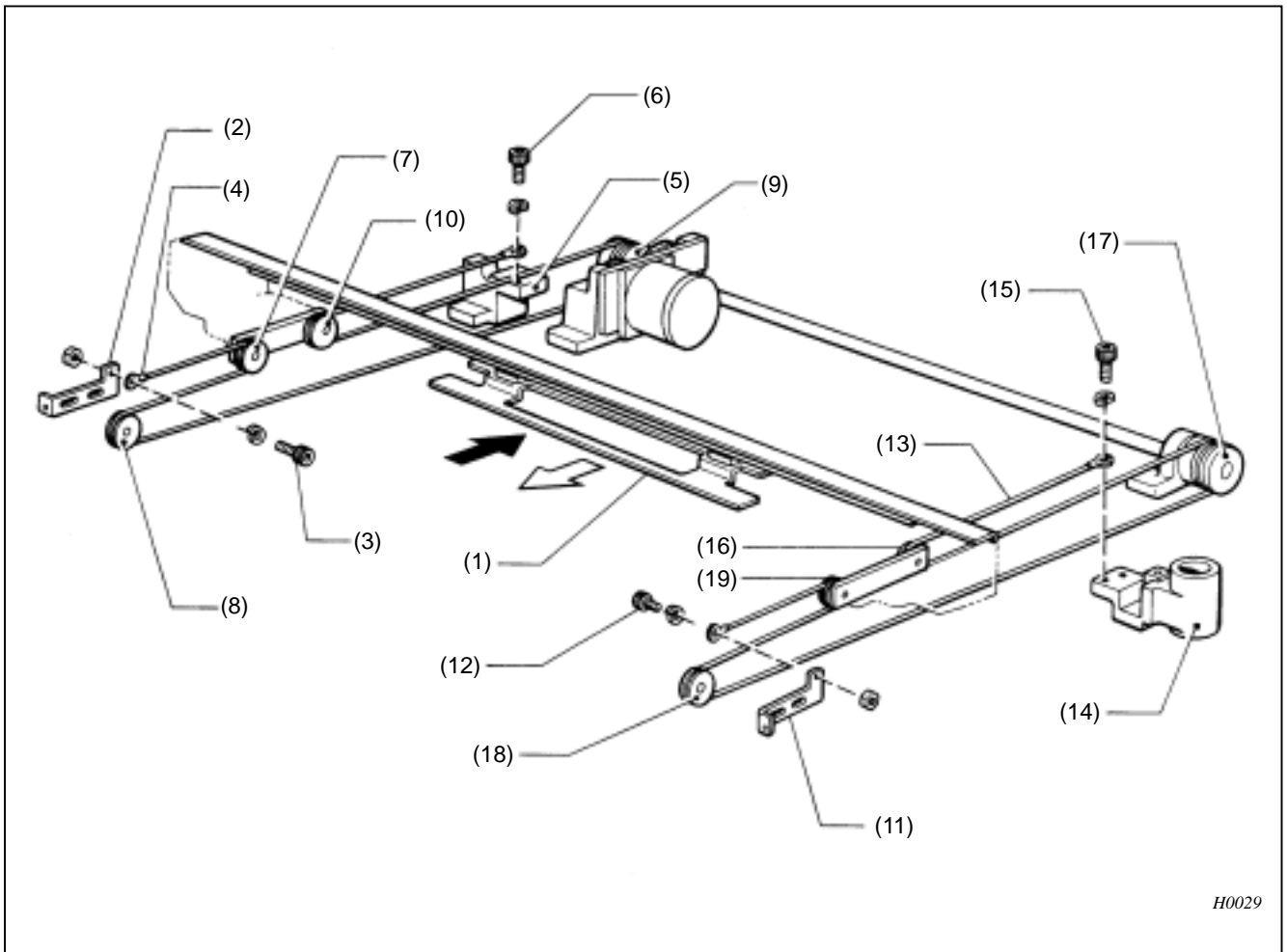

Remove Y wire L

1. Push the carriage (1) all the way to the back, and secure it.
2. Remove the bolt (3) of hook LY (2). Remove Y wire L (4) from both pulleys.
3. Remove the bolt (6) of stand RL (5).

Attach Y wire L

1. Attach Y wire L (4) end (the end furthest from the ball) to hook LY (2) using the bolt (3).
2. Put Y wire L (4) on pulleys (7) and (8), and place the wire ball into the hole of wire drum (Y) (9). Then wind the wire four times.
3. Put the wire around the pulley (10), and secure it to stand RL (5) using the bolt (6).

Remove Y wire R

1. Pull the carriage (1) forward and secure it.
2. Remove the bolt (12) from hook RY (11). Remove Y wire R (13) from both pulleys.
3. Remove the bolt (15) of stand RR (14), and Y wire R (13).

Attach Y wire R

1. Attach Y wire R (13) end (the end closest to the ball) to stand RR (14) using the bolt (15).
2. Put Y wire R (13) around the pulley (16), and place the wire ball into the hole of wire drum Y (17). Then wind the wire around the drum four times.
3. Feed the wire around the pulleys (18) and (19), and finally secure it to hook RY (11) using the bolt (12).

(MEMO) Y wires L and R are the same.

3-4. Adjusting the needle bar case position

3-4-1. BES-116AC

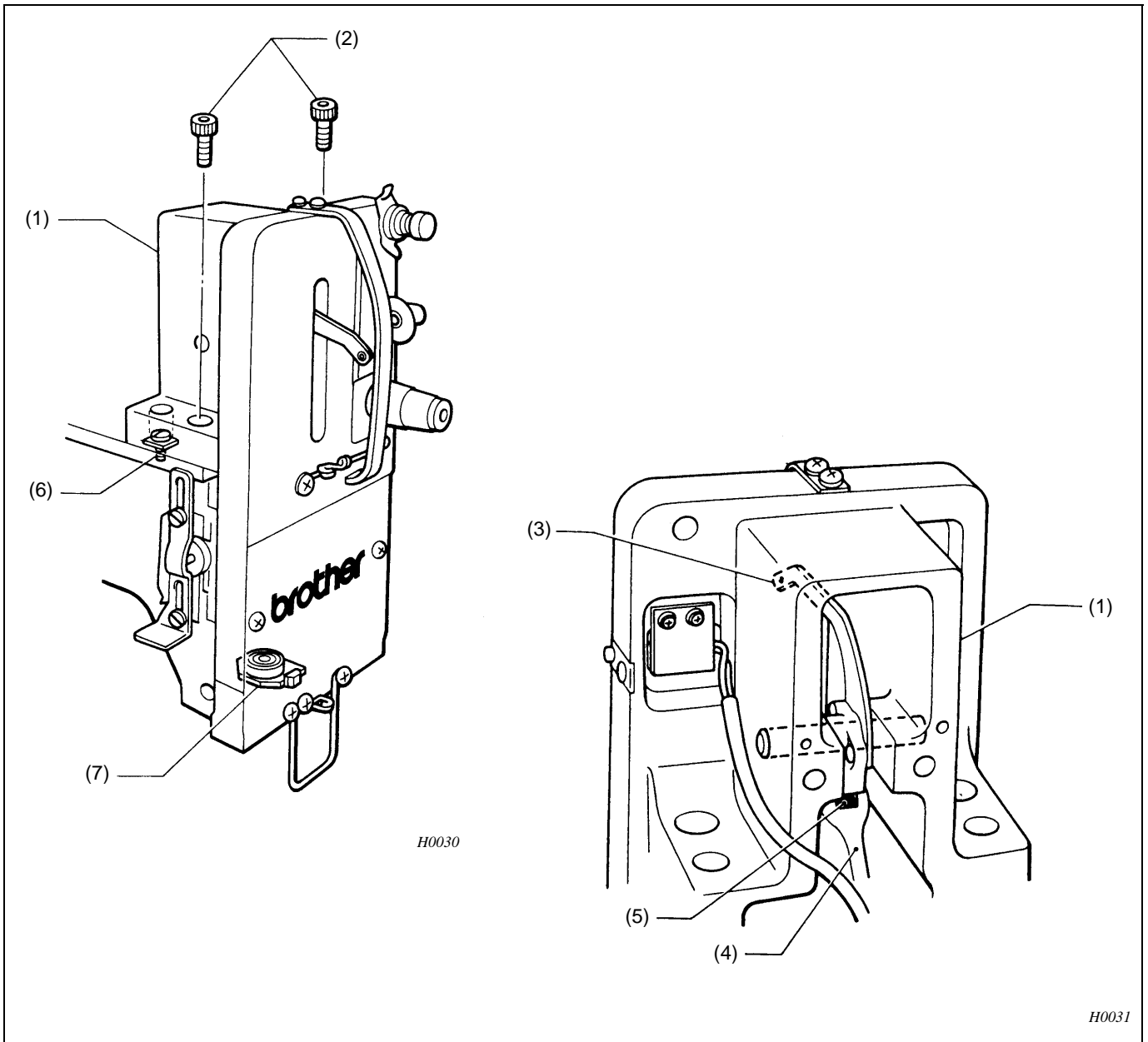

1. Remove two bolts (2), and the needle bar case (1).
2. When setting the needle bar case (1), make sure that the needle point is at the center of needle hole on the needle plate.
The thread take-up lever assembly (3) should be inserted into the roller (5) of the thread take-up driving lever (4).
3. Loosen two bolts (2) and two setscrews (6) to adjust the needle drop position.
4. Loosen two bolts 8 of the positioning plate (7) to adjust needle drop point to front or back.
(NOTE) Do not loosen the screws (6) unless it is really necessary.

3-4-2. BES-916AC, 1216AC

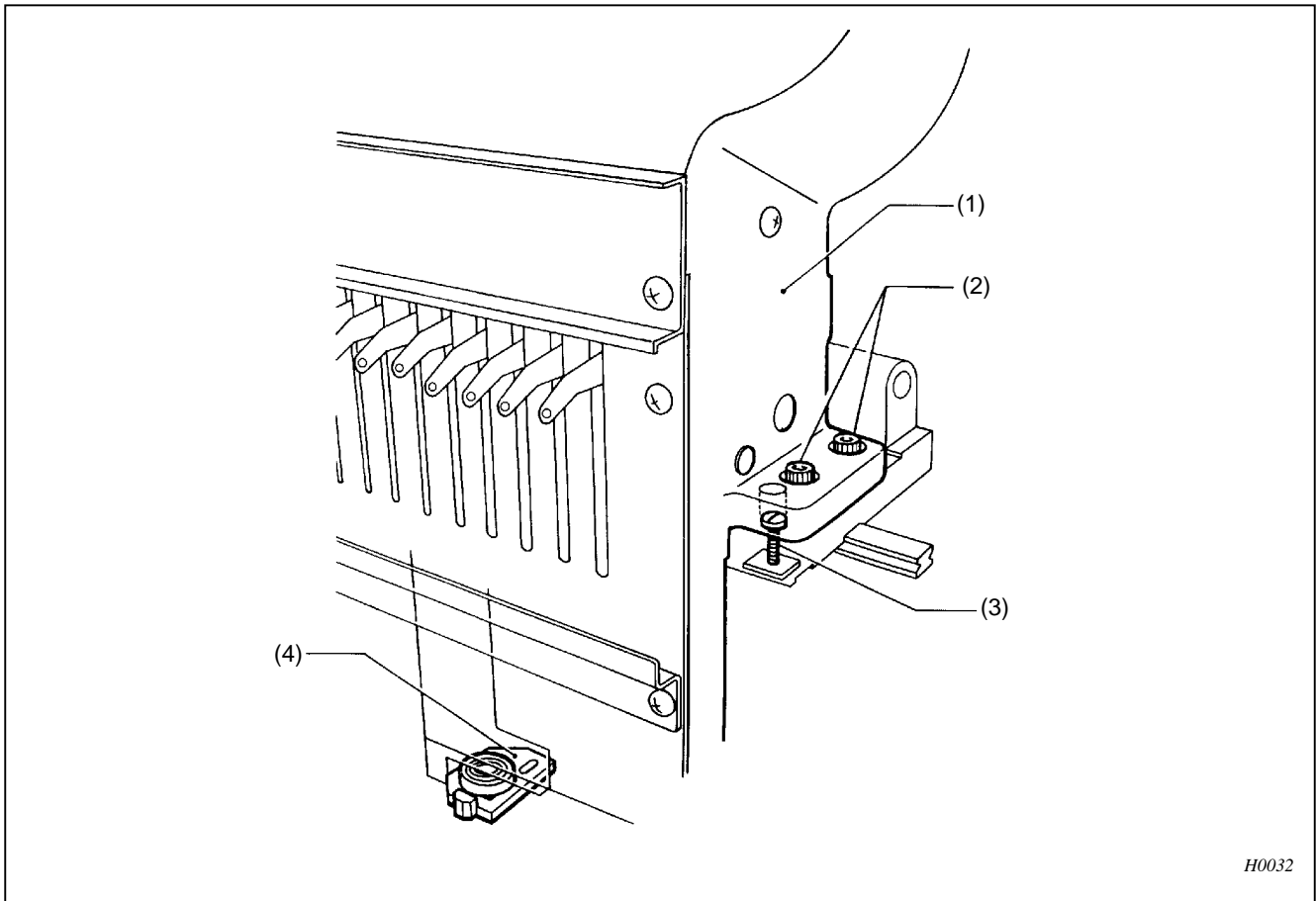

H0032

1. Remove the four bolts (2), and the needle bar case (1).
2. When setting the needle bar case, make sure the needle bar case has no clearance between its base, and the needle point is at the center of needle hole on the needle plate.
3. Loosen the two positioning pins (3) to adjust the needle bar case (1) movement or the needle movement; use the positioning plate (4) to adjust needle drop point to front or back.

(NOTE) Do not loosen the positioning pins (3) unless it is really necessary.

3-5. Replacing the thread take-up lever

3-5-1. BES-116AC

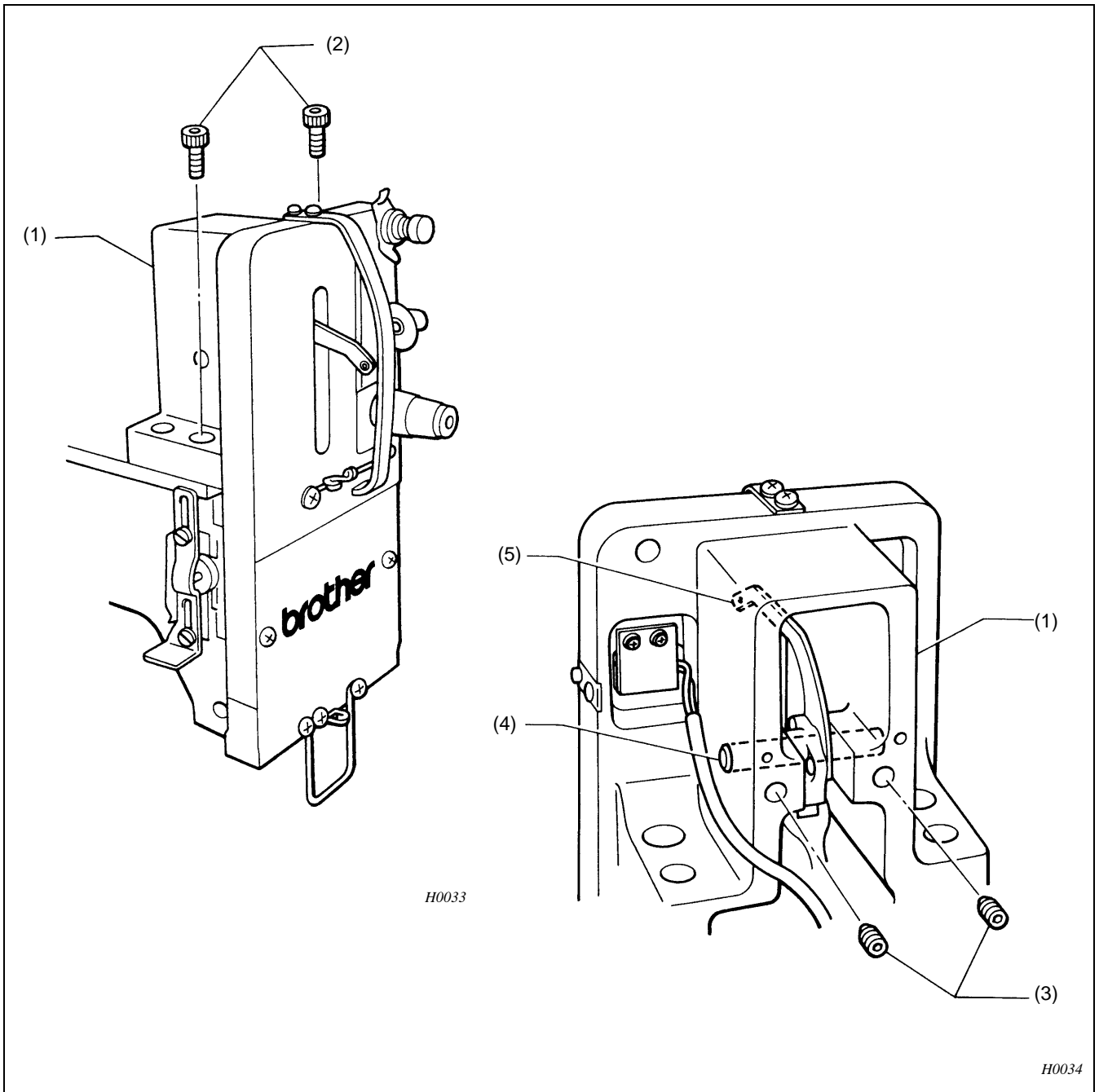

1. Remove the two bolts (2) and the needle bar case (1).
2. Loosen two set screws (3) from back of needle bar case.
3. Pull out the foot switch lever shaft (4), and remove the thread take-up lever (5).

* Reverse the above procedure for assembly.

3-5-2. BES-916AC, 1216AC

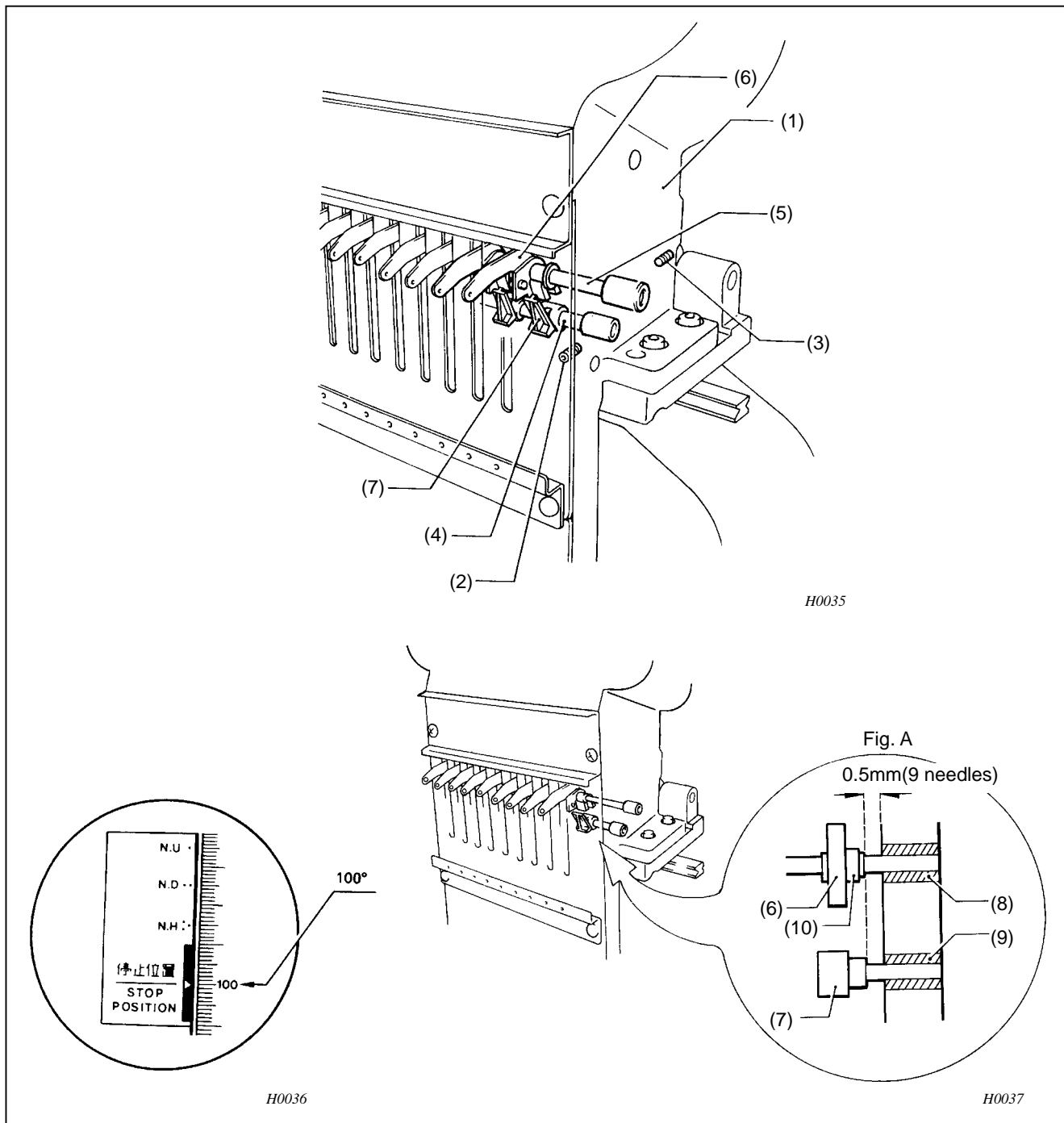

1. Loosen the set screw (2) on the right of the needle bar case (1) viewed from the front, and the set screws (3) on both sides from the rear of needle bar case (1).
2. Shift the thread take-up shaft (4) and the thread take-up bar shaft (5) 30-40mm in one direction, and remove the thread take-up lever (6) and thread take-up holding(s) (7).

(MEMO) Reverse the above procedure for assembly.

(NOTE) Notes on assembly.

- When attaching the thread take-up lever (6) and the thread take-up holding (7), set a clearance of 0.5 mm for 9-needle, 0.7 mm for 12-needle respectively, between the thread take-up shaft bush (8) and the thread take-up holding bush (9). The positions of the thread take-up holding (7) and the thread take-up lever (6) should be as shown in figure A; the thread take-up holding (7) should be inserted into the thread take-up boss (10) without getting on the thread take-up lever (6).
- When mark on the pulley is aligned with the one on the belt cover, all take-up levers should be aligned at their highest positions.

3-6. Replacing the needle bar (BES-116AC, 916AC, 1216AC)

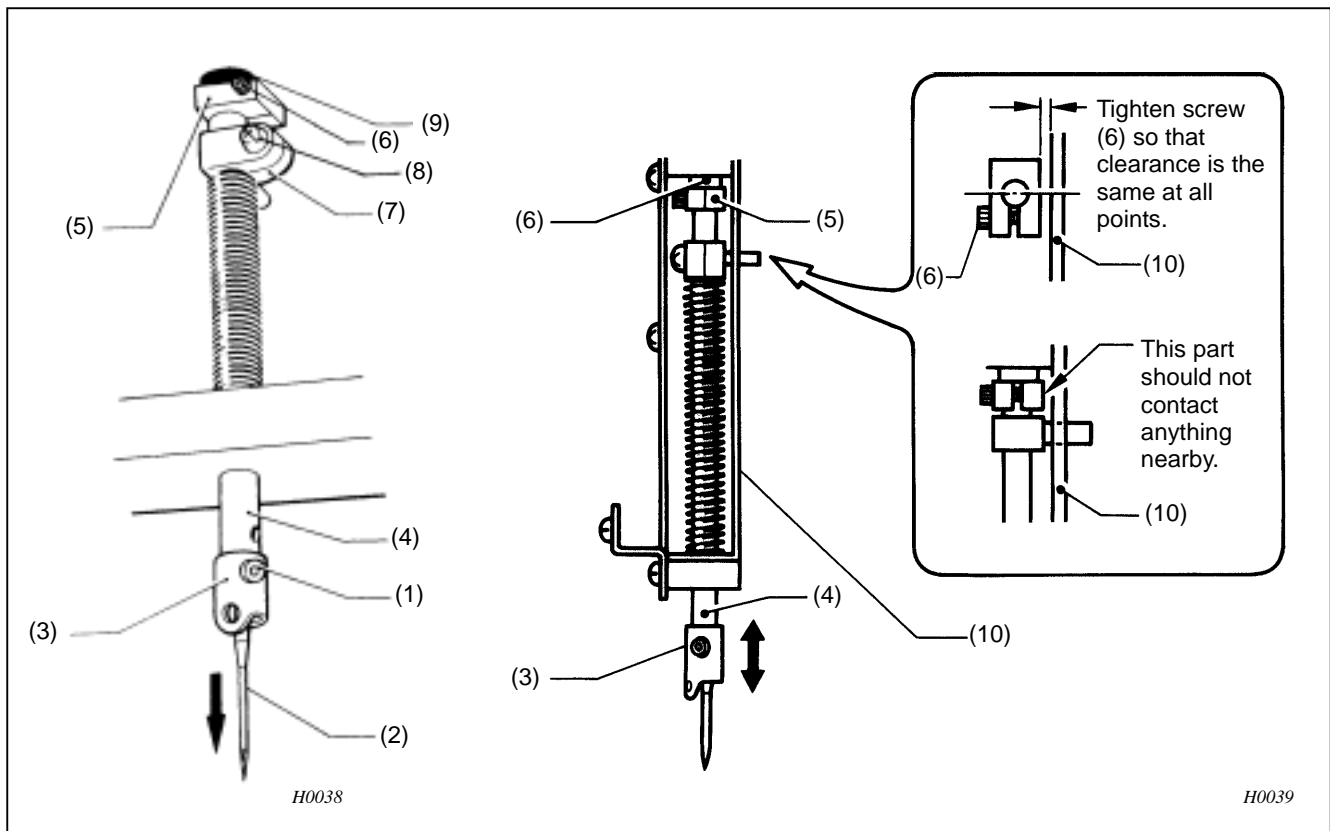

1. Remove the set screw (1), and the needle (2).
2. Remove the needle bar thread guide (3) from the needle bar (4).
3. Loosen the screw (6) of the top dead center stopper (5) and the screw (8) of the needle bar clamp (7).
4. Remove the needle bar (4) by pulling it downward. (the felt, the needle bar clamp (7), the spring, and the top dead center stopper (5), and the cushion rubber (9) will come off.)

(MEMO) Reverse the above procedure for assembly.

(NOTE) Notes on assembly.

- The needle bar thread guide (3) should be attached with its hole facing the front.
- The top dead center stopper (5) should be positioned so that it makes slight contact with the cushion rubber (9) when ■ mark on the pulley is aligned with the one on the belt cover, and that the needle bar (4) moves up and down smoothly.

Make sure that the top dead center stopper (5) does not make contact with the needle bar guide rail (10).

- Adjust the top dead center stopper when the jump bracket and the needle bar clamp are securely positioned.
- Refer to page 43 for adjusting the needle bar height.

3-7. Replacing the jump bracket (BES-116AC, 916AC, 1216AC)

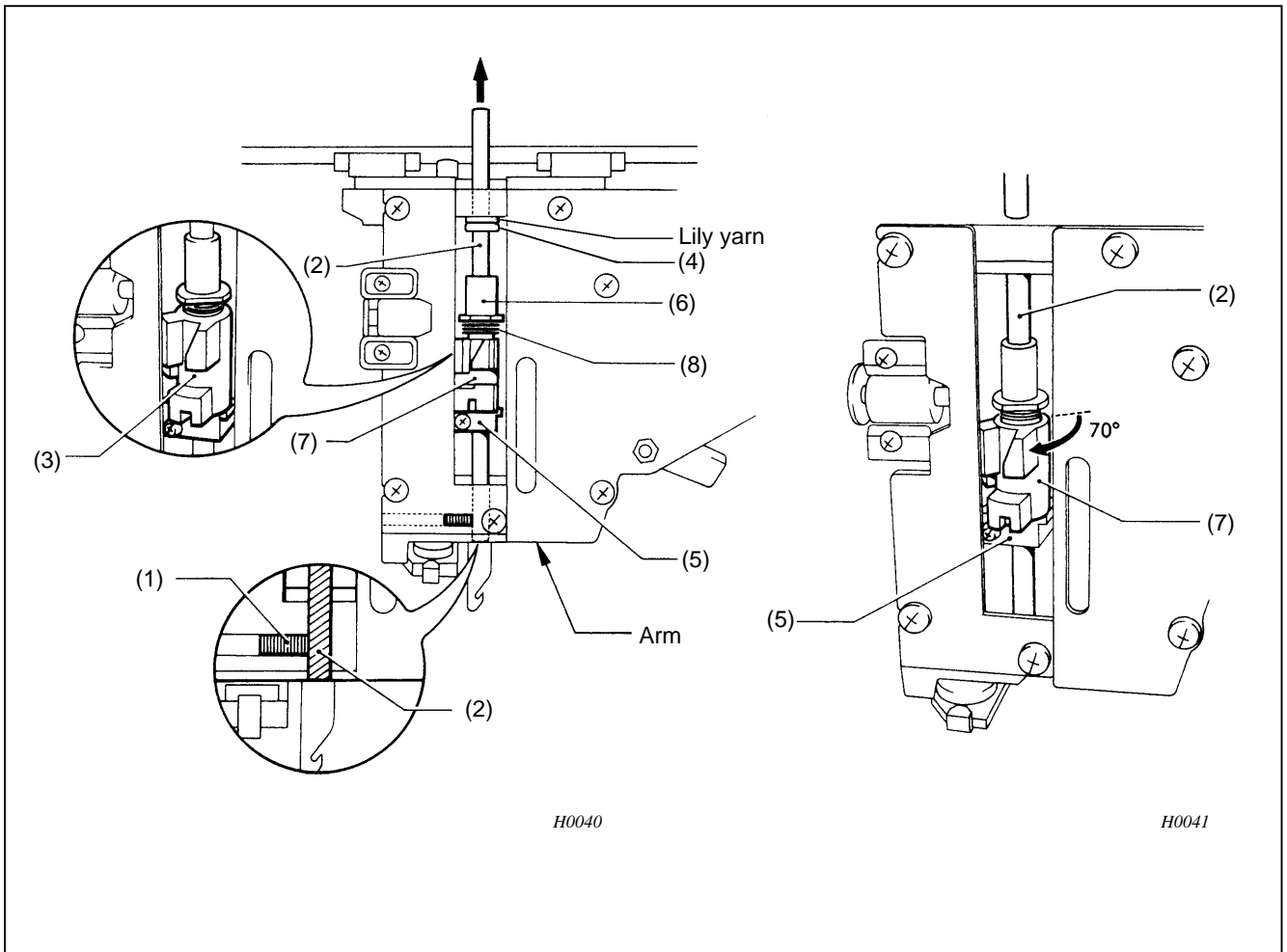

1. Loosen the screw (1) on the left of the machine head.
2. Pull out the base needle vertical-set bar (2) by lifting it from above.
The needle bar verticalset (3), the base needle bar felt (4) and the lily yarn will come off.
3. Loosen the screw of the jump clamp (5), and remove the jump clamp (5) and the jump bracket (7) from the base needle bar bush (6).
The spring (8) will come off.

(MEMO) Reverse the above procedure for assembly.

(NOTE) Notes on assembly:

- When loosening the screw of the jump clamp (5), pay attention to the position of the base needle bar bush (6) (the spring strength). The screw should be tightened so that the jump clamp can be moved easily without play (it can be moved vertically only 0.03 - 0.05 mm). When the jump bracket is turned 70° (where the flat surface of the base needle bar bush (6) faces the front).
- When attaching the base needle bar (2), align its bottom with the bottom of the arm.
- When attaching the base needle bar (2), be sure to thread a hoop of lily yarn through it.

3-8. Replacing and adjusting the jump solenoid (BES-116AC/96AC/1216AC)

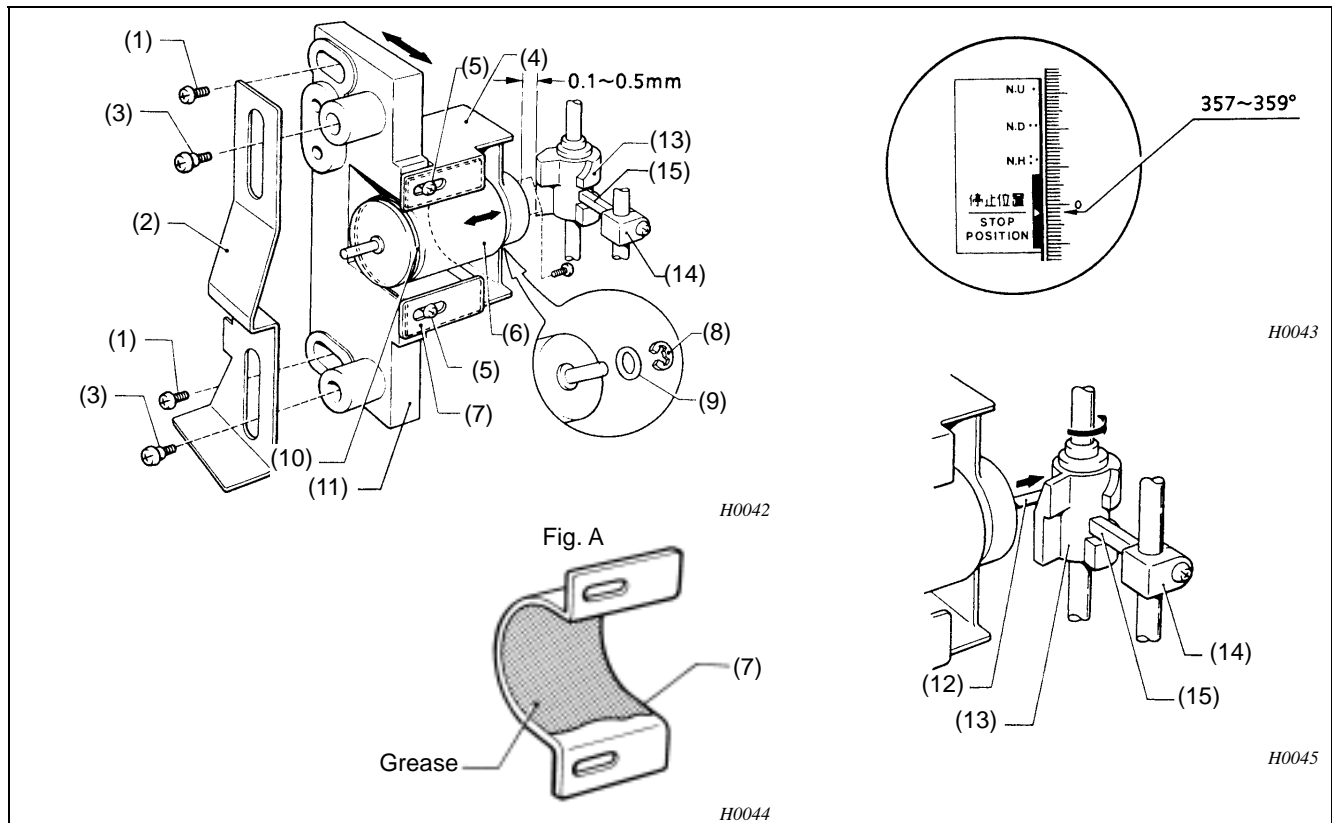

1. Remove the two screws (1) and the jump solenoid.
2. Remove the two shoulder screws (3) and the cam plate (2).
3. Remove the two screws (5) and the jump solenoid (6) from the jump solenoid bracket (4).
The jump solenoid heat slinger (7) will come off. (The jump solenoid and the jump solenoid heat slinger are coated with silicon grease.)
4. Remove the retaining ring (8) of the jump solenoid (6), and the O ring (9).
5. Remove the solenoid cushion (10) from the shaft of the jump solenoid (6).
6. Replace the jump solenoid (6) with a new one.
7. Attach the solenoid cushion (10), the O ring, and the retaining ring (8).
(NOTE) Do not forget to put the attached spring back.
8. Attach the replaced jump solenoid (6) to the jump solenoid heat slinger (7) after coating with silicon grease (equivalent to silicon grease G746 made by Shin-etsu Chemical Co.,Ltd.).
(NOTE) To apply silicon grease to the jump solenoid heat slinger (7), refer figure A.
9. Attach the jump solenoid (6) and the jump solenoid heat slinger (7) to the jump solenoid bracket (4) using the two screws.
(NOTE) Make sure that the jump solenoid works correctly by pressing it with a finger after tightening the screws.
(NOTE) Apply silicon grease to the contact surfaces of both the jump solenoid heat slinger (7) and the jump solenoid base (11).

-
10. Attach the cam plate (2) to the side of the machine head using the shoulder screw. Attach the jump solenoid to the side of the machine head using the two screws (1).

Secure the jump solenoid at the position where the jump bracket (12) is separated from the protrusion of the needle bar clamp (13) (when the pulley is turned 357° - 359°) when the pin (14) of the jump solenoid protrudes the most.

If it is hard to turn the pulley manually, slide up the cam plate (set the solenoid to jump condition), operate the machine at its lowest speed, and make sure that the needle is kept at its highest position without moving.

If the needle moves, move the jump solenoid toward you (toward the needle bar case) slightly.

11. Loosen the two screws of the jump solenoid bracket (4), move it in parallel with the jump bracket (12) to adjust the clearance between them to 0.1-0.5mm.

3-9. Replacing the synchronizer and the sensor circuit board(BES-116AC, 916AC, 1216AC)

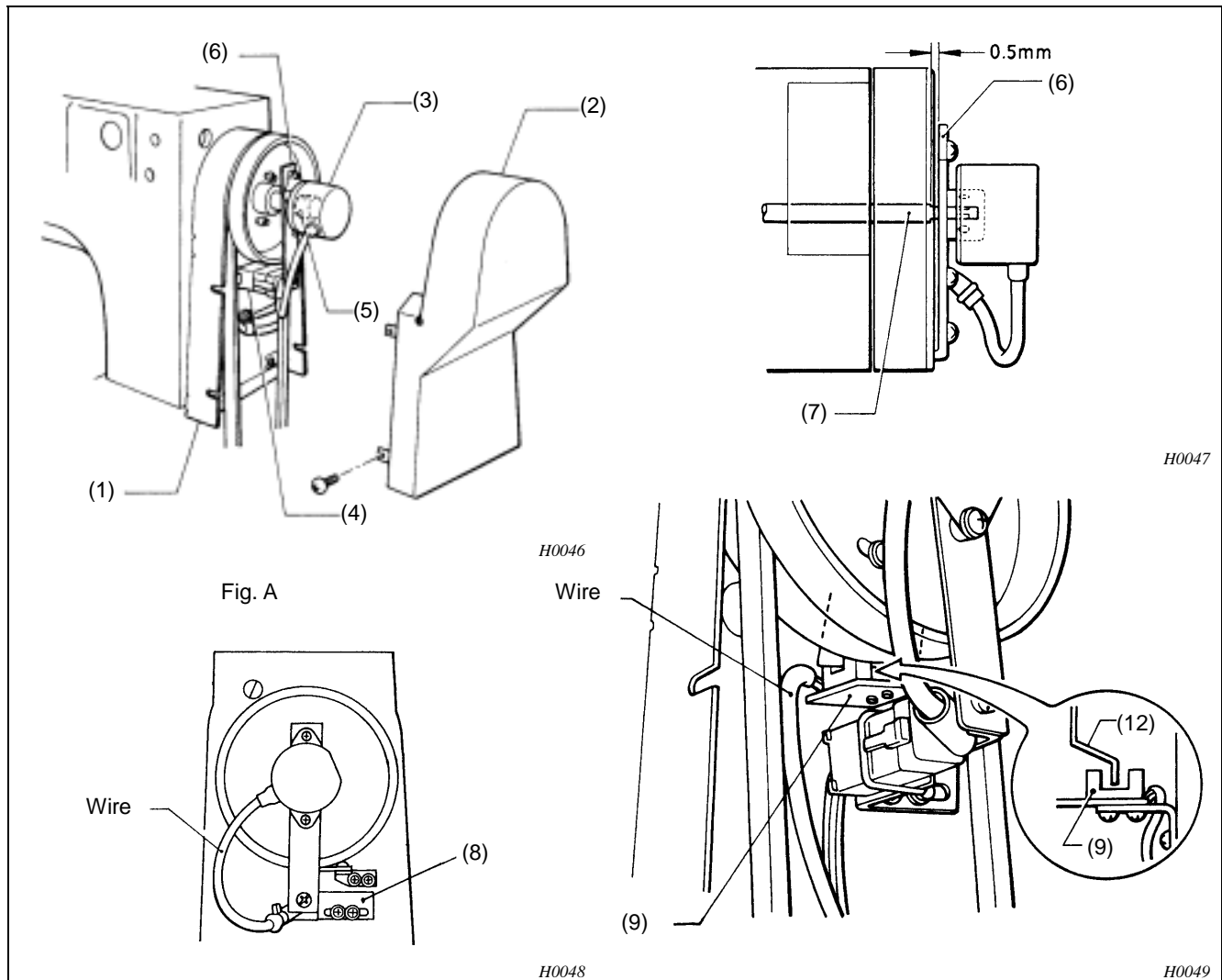

Replacing the synchronizer

1. Remove the four screws, and belt cover B (1) • A (2).
2. Remove the connector (4) of the rotary encoder (3) from the machine head.
3. Loosen the two set screws of the rotary shaft (5) attached to the rotary encoder (3).
4. Remove the two screws, and the rotary encoder (3) from the encoder bracket (6).

(MEMO) Reverse the above procedure for assembly.

(NOTE) Notes on assembly

- When attaching the rotary encoder, tighten the set screw of the rotary shaft so that the one which first comes in the rotation direction is aligned with the screw flat of the driving shaft.
- Ensure the clearance between the edge of the encoder bracket (6) and the edge of the driving shaft (7) is 0.5mm, and attach the rotary encoder so that it is perpendicular to the encoder set plate (8).
- The rotary encoder should be attached so that its cord is positioned to the left (when viewed from the rear) as shown in figure A.

Replacing the sensor circuit board

1. Remove the connector (10) of the sensor circuit board (9).
2. Remove the two screws, and the sensor circuit board (9) from the needle position sensor set plate (11).

(MEMO) When replacing the sensor circuit board, reverse the above procedure.

(NOTE) Note on assembly:

- Make sure that the zero bight needle locating dog (12) should be positioned in the center of the sensor circuit board (9). (Refer to "Adjusting the machine stop position signal")
- One end of the sensor circuit board (9) wire should be positioned at the arm.

3-10. Replacing and adjusting the parts related to the presser foot(BES-116AC, 916AC, 1216AC)

3-10-1. Replacing the presser foot

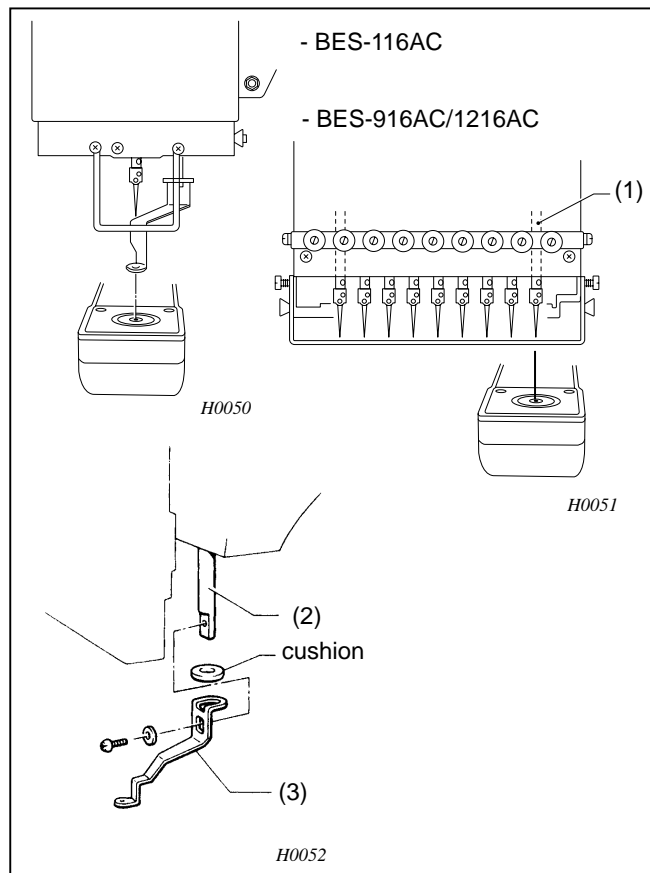

1. Select the first needle bar (1) for the BES-916AC and BES-1216AC.
2. Remove the screw, the washer, and the presser foot (3) from the presser shaft (2).
When removing the presser foot, the presser cushion will come off.

(MEMO) Reverse the above procedure for assembly.

3-10-2. Replacing and adjusting the presser shaft when the needle bar case is attached

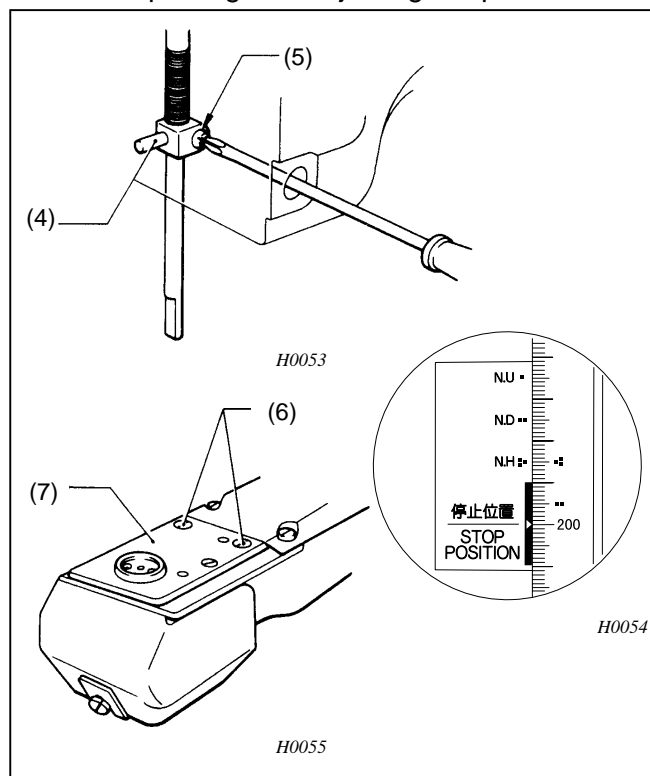

1. Select the first needle bar (1) for the BES-916AC and BES-1216AC.
2. Remove the presser foot (3) from the presser shaft (2).
3. Remove the oil cap on the side of the machine head, insert a screwdriver into the hole, and loosen the screw (5) of the presser shaft clamp (4) (when the presser foot is set to its lowest position).
4. Remove the screw (6), and the needle plate (7).

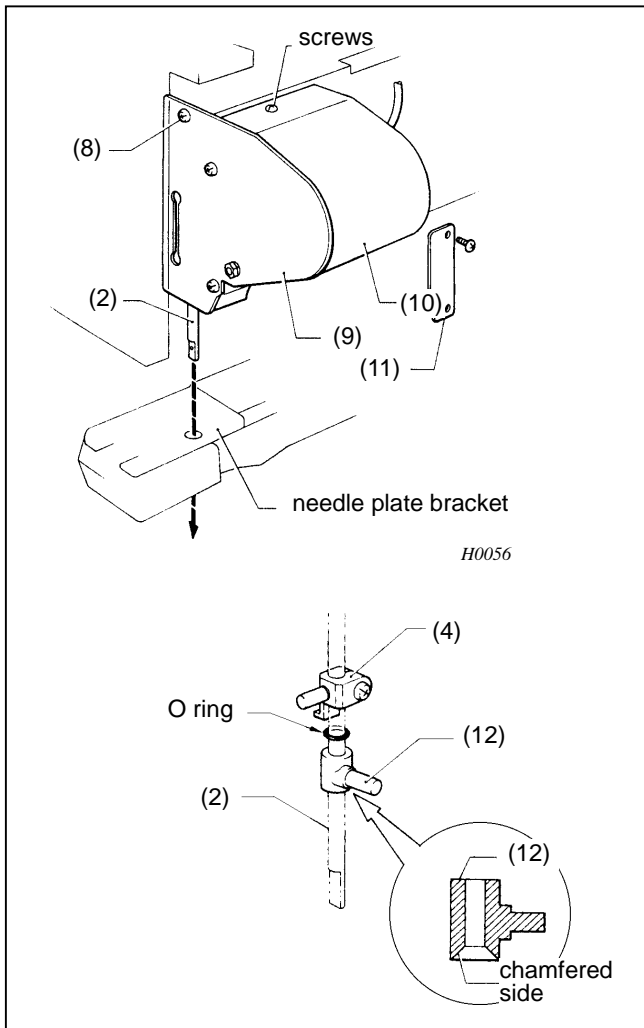

5. Remove the three screws (8), and the presser guide plate (9).
6. Remove the three screws, and the solenoid cover (10). Remove the two screws, and the presser cover (11).
7. Remove the presser shaft (2) by pulling it downward, and pass it through the hole of the needle plate bracket.

(NOTE) The presser shaft can also be removed from the above if it cannot be removed downward because of being bent.

(When removing the presser shaft from above, remove the needle bar case.)

(NOTE) When removing the presser shaft, the spring may pop out. Be careful.

(MEMO) Reverse the above procedure for assembly.

(NOTE) Notes on assembly

- The screw of the presser shaft clamp (4) should be kept loose.
- Be sure to insert the O ring between the presser shaft clamp (4) and the presser operating base (12) before attaching the presser shaft (2).
- When attaching the presser guide plate, apply adhesive to the portion, which touches the machine head.
- Attach the presser operating base (12) with the chamfered side facing down.

3-10-3. Adjusting the presser shaft when the needle bar case is attached

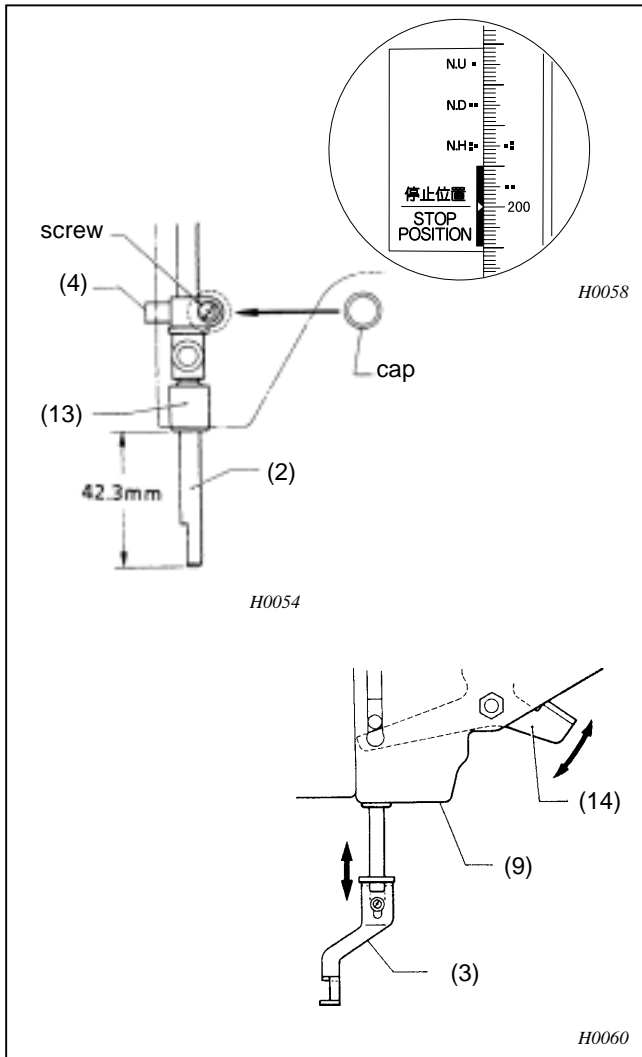

1. Turn the pulley to set the presser foot to its lowest position.
2. Move the presser shaft (2) up or down to adjust it so that the distance from the end of the bush (13) to the presser shaft (2) is 42.3mm.
3. Securely tighten the screw of the presser shaft clamp (4).
4. Cover the hole in the side of the machine head with the oil cap.
5. Make sure that the presser foot (3) rises and lowers smoothly by moving it manually (using the presser retracting lever (14)).

(NOTE) If the presser foot has stopped halfway while being raised, the presser guide plate (9) may be attached on an angle.

(NOTE) When tightening the screw of the presser shaft clamp, attach the presser foot to the end of the presser shaft, and position the hole in the needle plate in the center of the hole of the presser foot.

3-10-4. Replacing the presser retracting lever

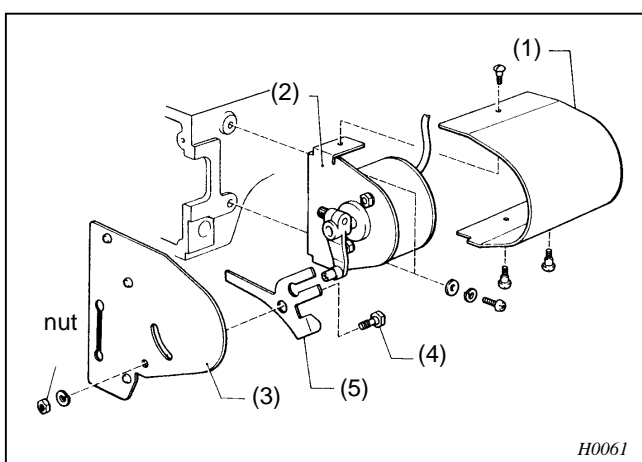

1. Remove the three screws, and the solenoid cover (1).
2. Remove the two screws, and the presser solenoid set plate (2) from the arm.
3. Remove the nut of the retracting lever shaft (4) from the presser guide plate (3), then the presser retracting lever (5).

(MEMO) Reverse the above procedure for assembly.

3-10-5. Replacing the retracting solenoid lever

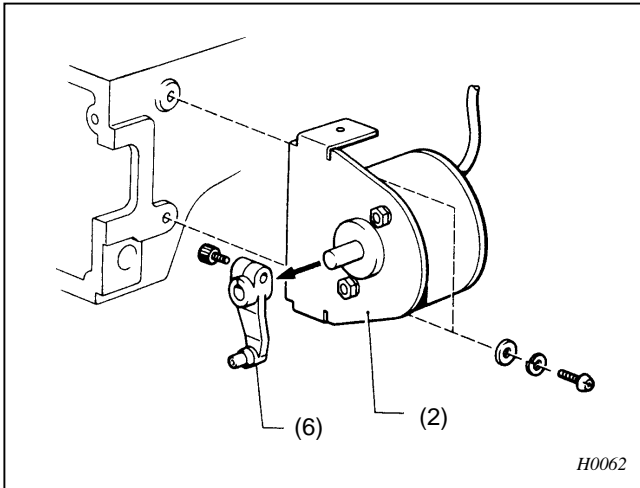

1. Remove the three screw, and the solenoid cover (1).
2. Remove the two screws, the presser solenoid set plate (2) along with the solenoid from the arm.
3. Loosen the screw, and remove the retracting solenoid lever (6) from the solenoid.

(MEMO) Reverse the above procedure for assembly.

3-10-6. Adjusting the presser retracting lever and the retracting solenoid lever

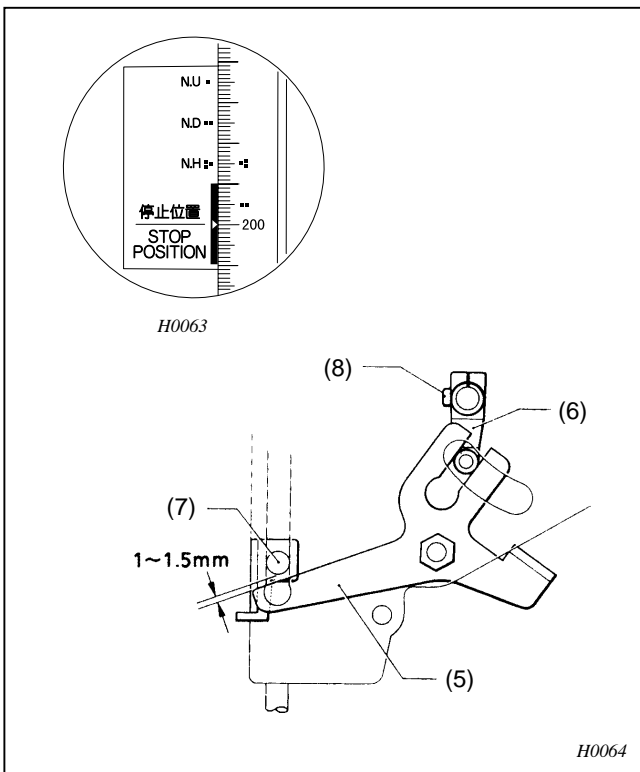

(NOTE) Before making this adjustment, turn off the solenoid.

When the presser foot is set to its lowest position by turning the pulley, there should be a 1-1.5mm clearance between the presser retracting lever (5) and the shaft of the presser shaft clamp (6). Loosen the screw (7) of the retracting solenoid lever (4) to adjust it.

3-10-7. Replacing the presser retracting solenoid

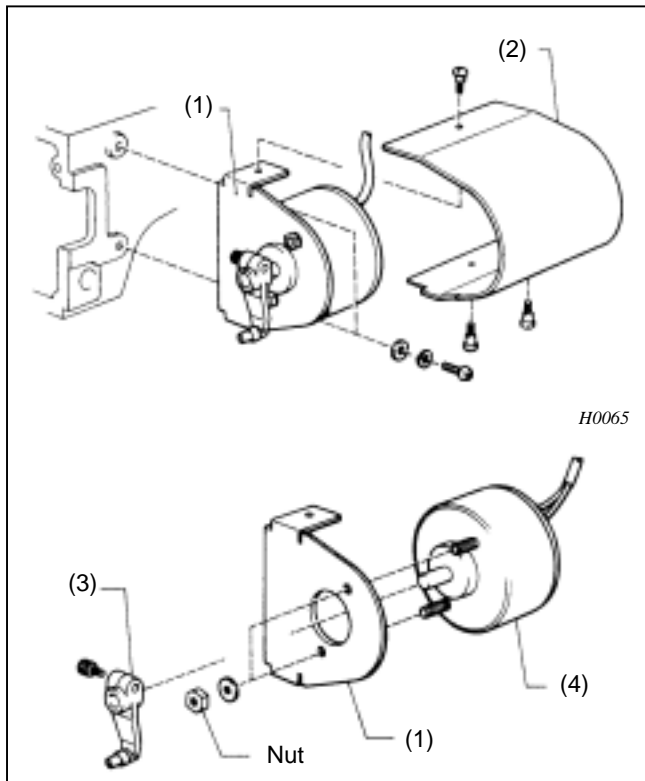

1. Remove the three screws, and the solenoid cover (2) from the presser solenoid set plate (1).
2. Remove the two screws, and the solenoid set plate (1) from the arm.
3. Loosen the bolt of the retracting solenoid lever (3), and remove it from the presser retracting solenoid (4).
4. Remove the two nuts, and the presser retracting solenoid (4) from the presser solenoid set plate (1).

(MEMO) Remove the connector along with it. Reverse the above procedure for assembly.

3-10-8. Adjusting the presser retracting solenoid

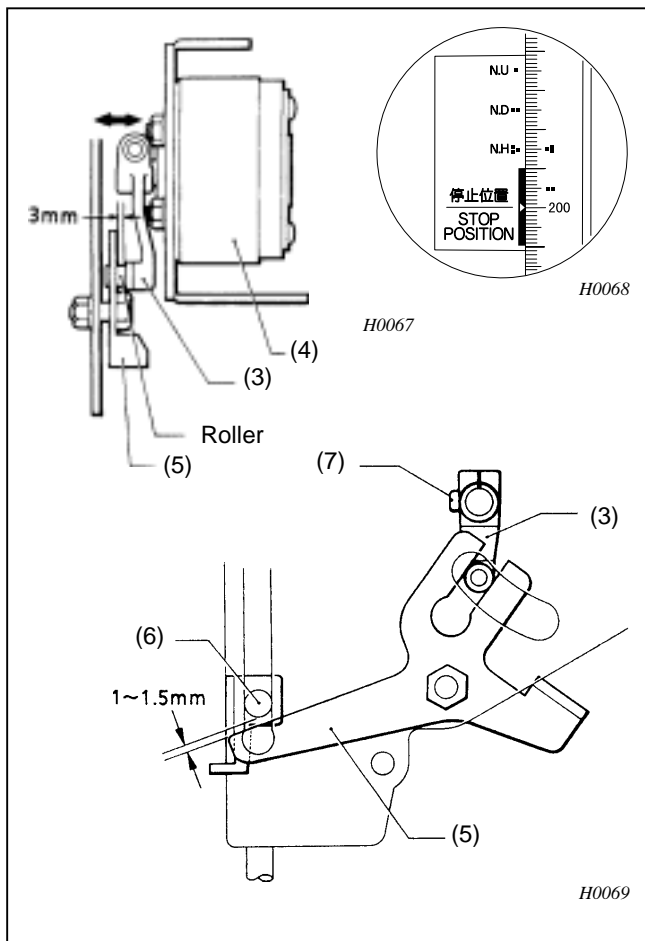

1. Move the retracting solenoid lever (3) back and forth to set the clearance between the roller of the retracting solenoid lever (3) and the presser retracting lever (5) to 3 mm (when presser retracting solenoid is off) after replacing the presser retracting solenoid (4).
2. Turn the pulley to set the presser foot in its lowest position. (Turn the pulley until ■ mark on the pulley is aligned with the one on the belt cover.) Loosen the screw (6) of the retracting solenoid lever (3), and adjust the clearance between the presser retracting lever (5) and the shaft of the presser shaft clamp (7) to 1-1.5mm.

3-11. Replacing and adjusting the parts related to the needle bar flip-up mechanism (BES-916AC)

3-11-1. Replacing the cam gear

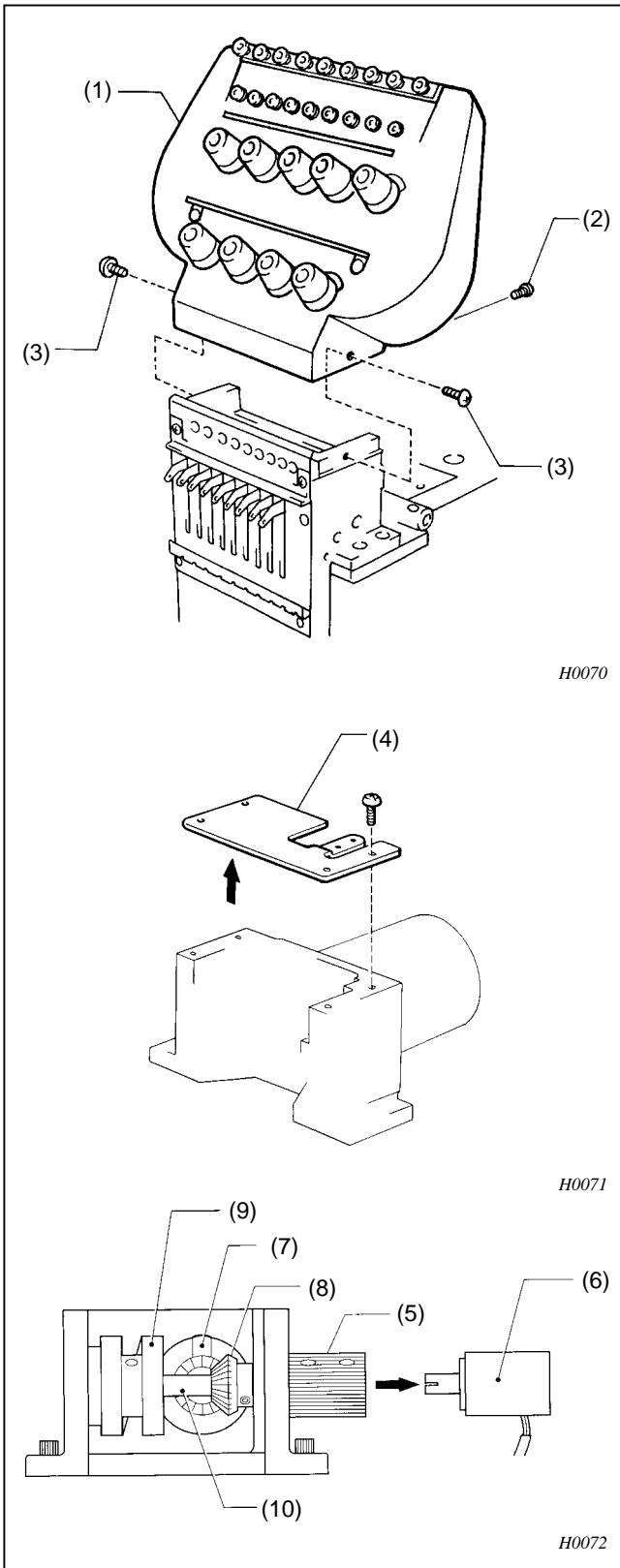

1. Remove the one connector from the rear of the adjustment base (1).
2. Remove the screws (3) right and left side loosen the screws (2) from the rear of the adjustment base (1).

(NOTE) BE sure to check the needle location before removing the adjustment base.

3. Remove the four screws, and the circuit board base (4).

4. Loosen the set screws, and remove the change collar (5) from the potentiometer (6).
5. Loosen each set screw of cam gears A (7) and B (8), and the change cam (9). Remove the cam shaft (10).

(NOTE) Do not remove the change collar (5).

3-11-2. Assembly

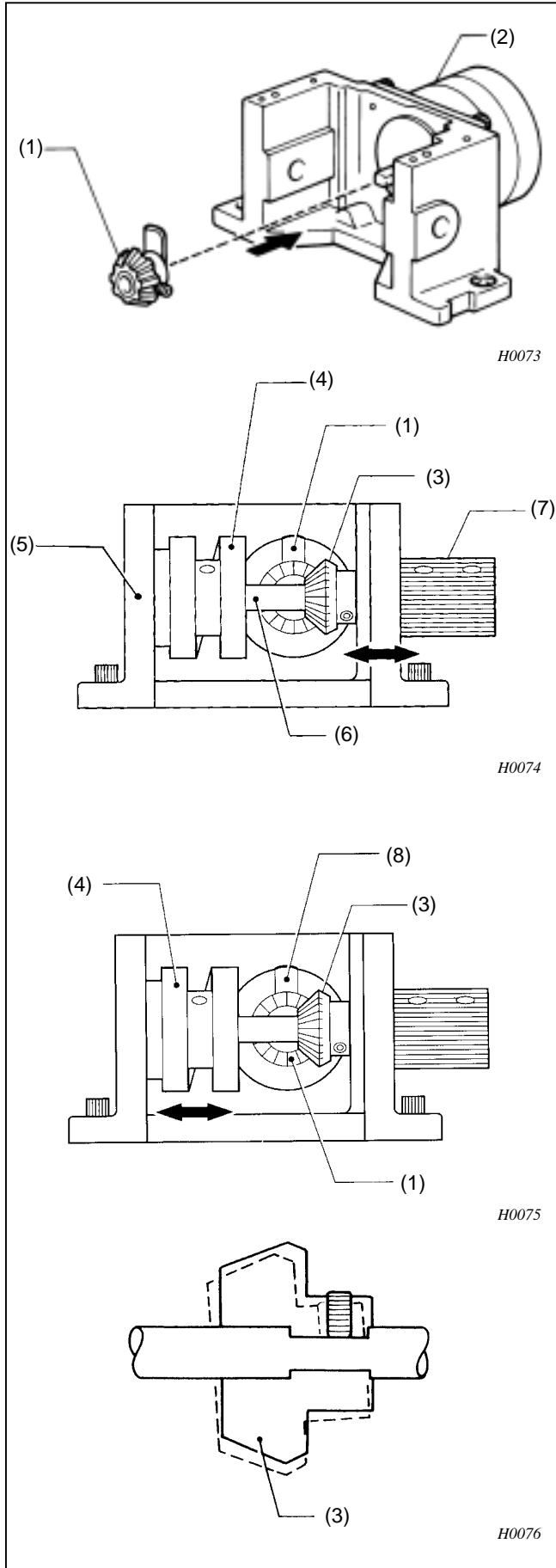

1. Temporarily attach cam gear A (1) to the shaft of the pulse motor (2).
2. Insert the cam shaft (6) into cam gear B (3) and the change cam. (4) inside of the change box (5), and temporarily attach the change cam (4) and cam gear B (3) using the set screws.
 Attach the change collar (7) and cam gear B (3) so that they are either side of the change box (5).
 Set a margin from 0.02 to 0.05mm in the direction of the shaft.

3. Turn the change cam (4) until it comes to the stop position (where the needle bar does not move) to check the needle location. If it has shifted, loosen the set screw of the change cam (4), and adjust its position by moving it in the direction of the shaft.
4. Put cam gear A (1) to cam gear B (3), and tighten the setscrew of cam gear A (1).
5. Loosen the set screw of cam gear B (3), and retighten it until the dog (8) of cam gear A (1) comes to the top.

- (NOTE) Make sure that cam gear B (3) is not inclined by its edge getting into the screw flat notch of the cam shaft. If it does, it cannot work smoothly.
- (NOTE) Make sure that all set screws are tightened.

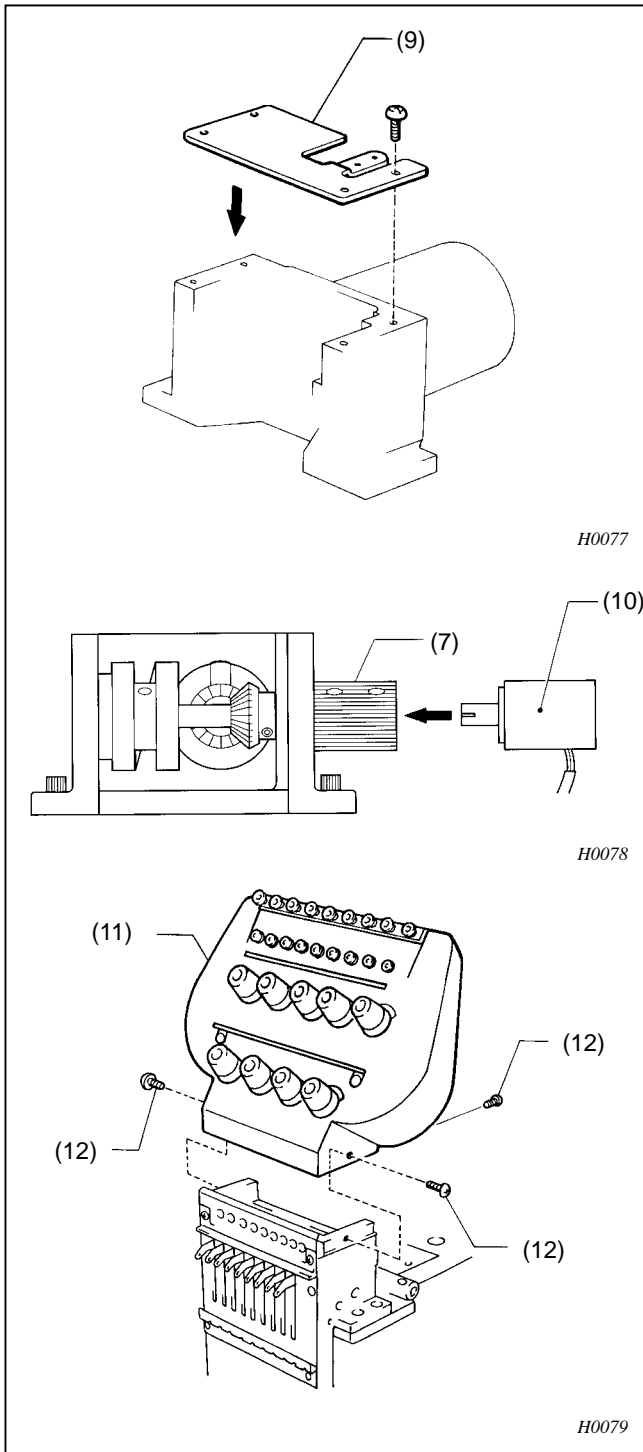

6. Attach the circuit board base (9) using the four screws.

7. Attach the change collar (7) to the potentiometer (10) with the set screws.

(NOTE) Refer to "Replacing an adjusting the potentiometer assembly"

8. Attach the adjustment base (11) using the four screws (12).

Replacing and adjusting the parts related to the needle bar flip-up mechanism (BES-1216AC)

Replacing the cam gear

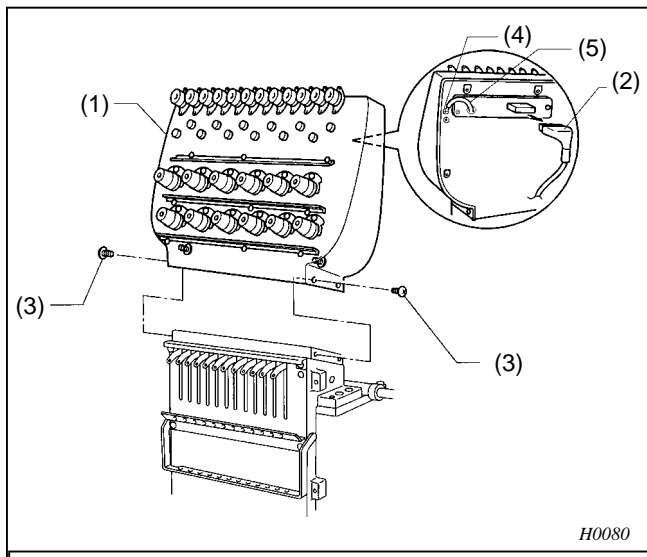

1. Remove the connector (2) from the rear of the adjustment base (1).
2. Loosen the bolt (4) and remove the earth cable(5).
3. Remove the two screws right and left side loosen the screws (3) from the rear of the adjustment base (1).

(NOTE) Be sure to check the needle location before removing the adjustment base (1).

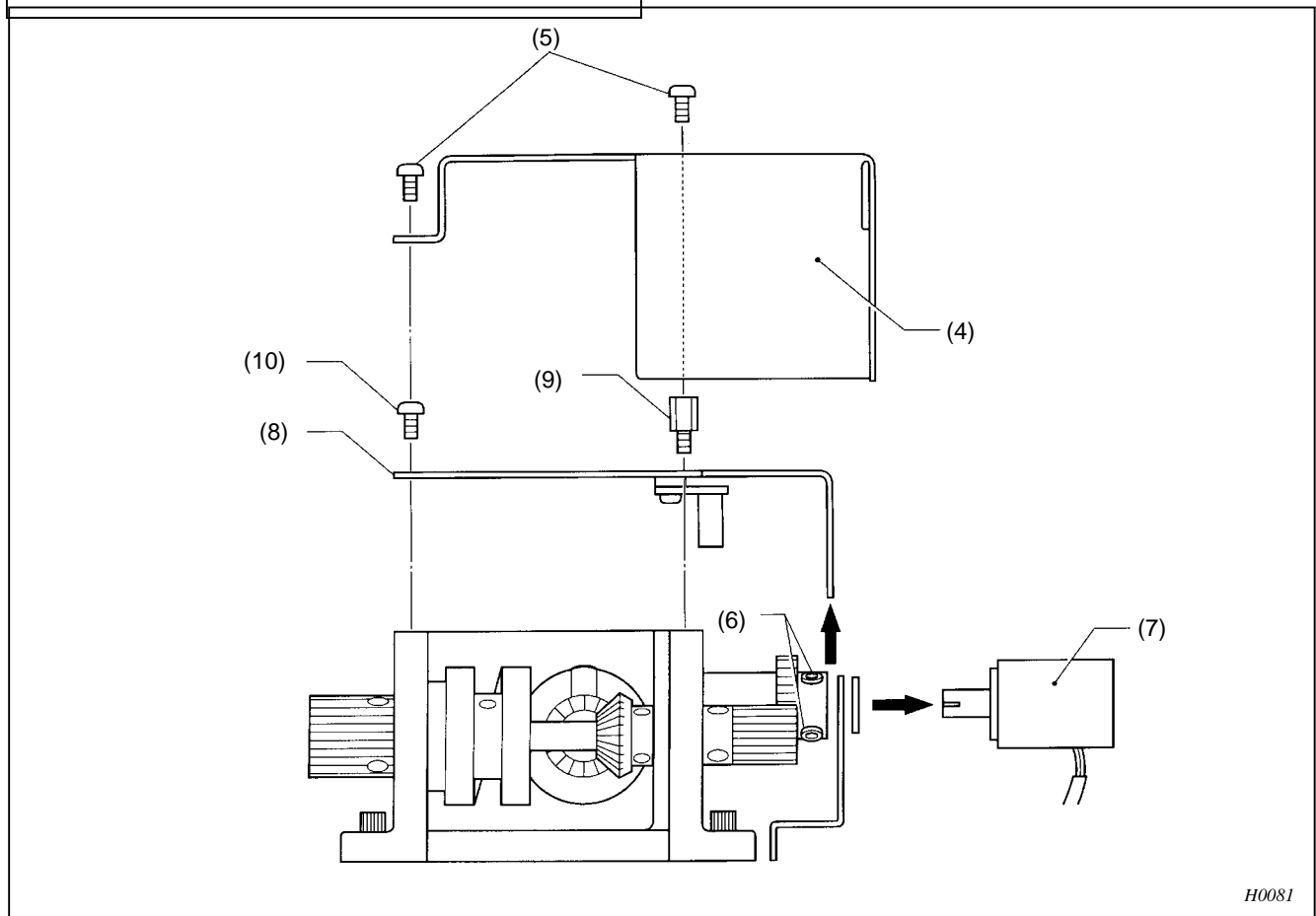

4. Remove the three screws (5) and the change box cover (4).
5. Loosen the set screws and remove the reduction gear B (6) the potentiometer (7).
6. Remove the two spacers (9) and the screw (10) and the base (8).

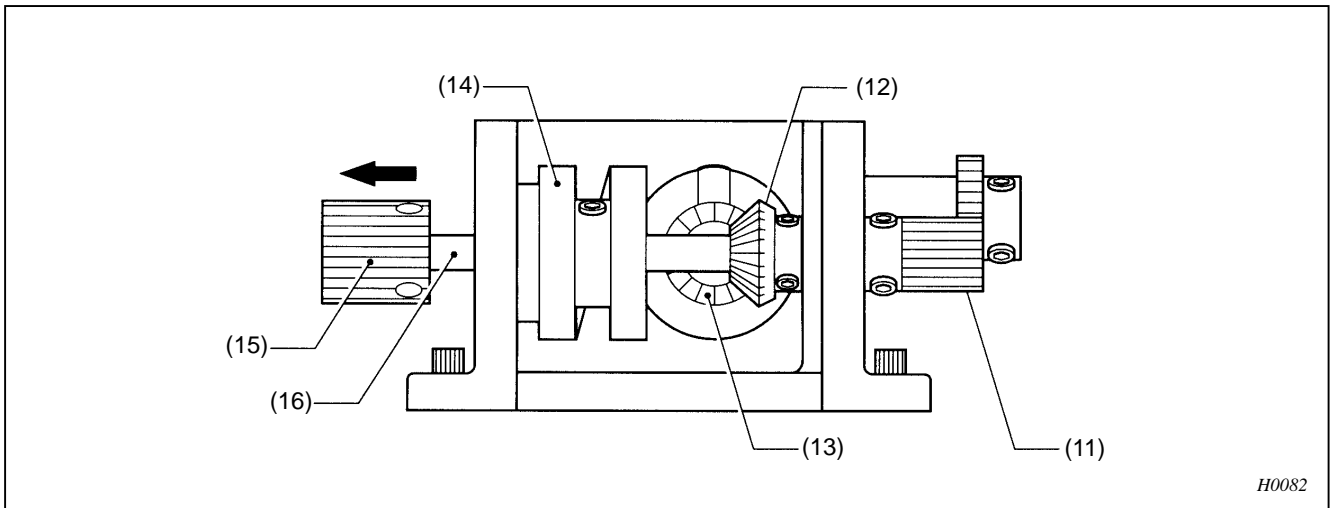

H0082

7. Loosen each set screws of cam gears A (13) and B (12), and reduction gear A (11) and the change cam (14) remove the cam shaft (16).

Assembly

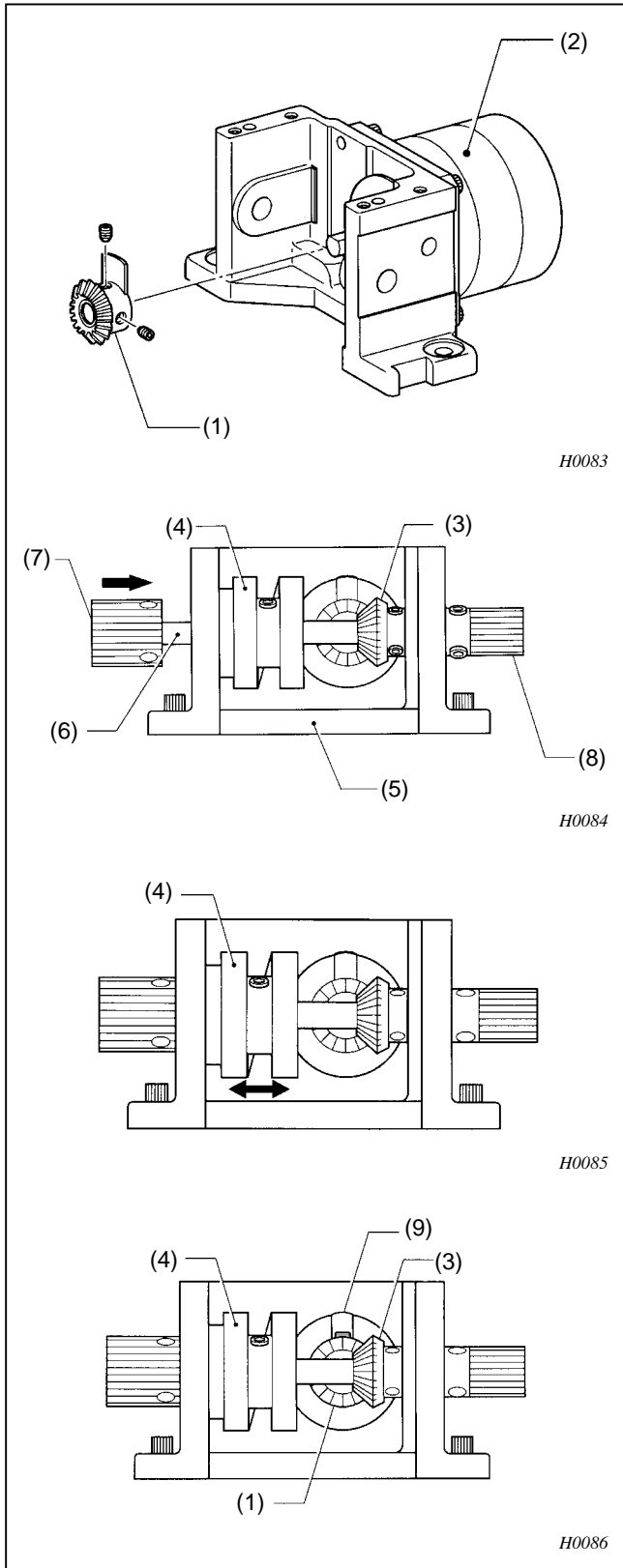

1. Temporarily attach cam gear A (1) to the shaft of the pulse motor (2).

2. Insert the cam shaft (6) into cam gear B (3) and the change cam (4) inside of the change box (5), and temporarily attach the change cam (4) and reduction gear A (8) using the set screws.

Attach the change collar (7) and cam gear B (3) so that they are either side of the change box (5).

Adjust the end play so that micrometer indicates from 0.02 to 0.05.

3. Turn the change cam (4) until it comes to the stop position (Where the needle bar does not move) to check the needle location. If it has shifted, loosen the set screw of the change cam (4), and adjust its position by moving it in the direction of the shaft.

4. Put cam gear A (1) to cam gear B (3), and tighten the set screw of cam gear A (1).

5. Loosen the set screw of cam gear B (3), and retighten it until the dog (9) of cam gear A (1) comes to the top.

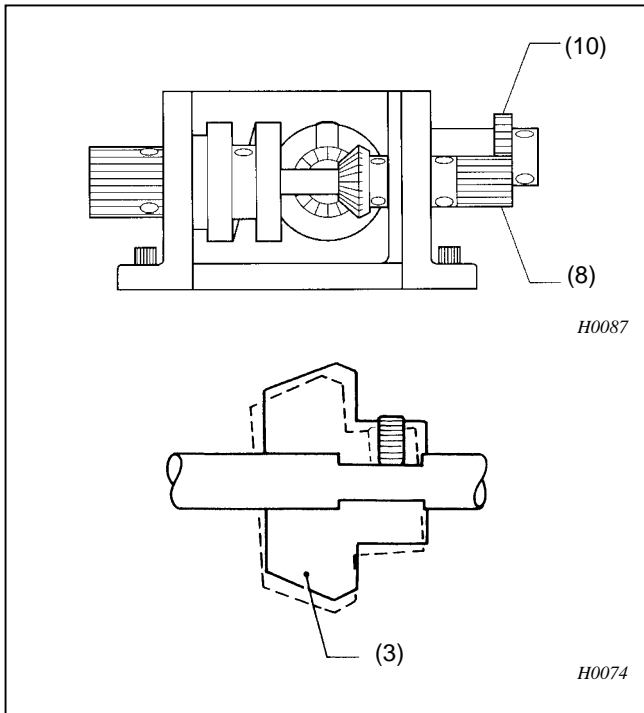

6. Loop the reduction gear A (8) around the reduction gear B (10) with the set screw.

(NOTE) Make sure that cam gear B (3) is not inclined by its edge getting into the screw flat notch of the cam shaft. If it does, it cannot work smoothly.

(NOTE) Make sure that all set screws are tightened.

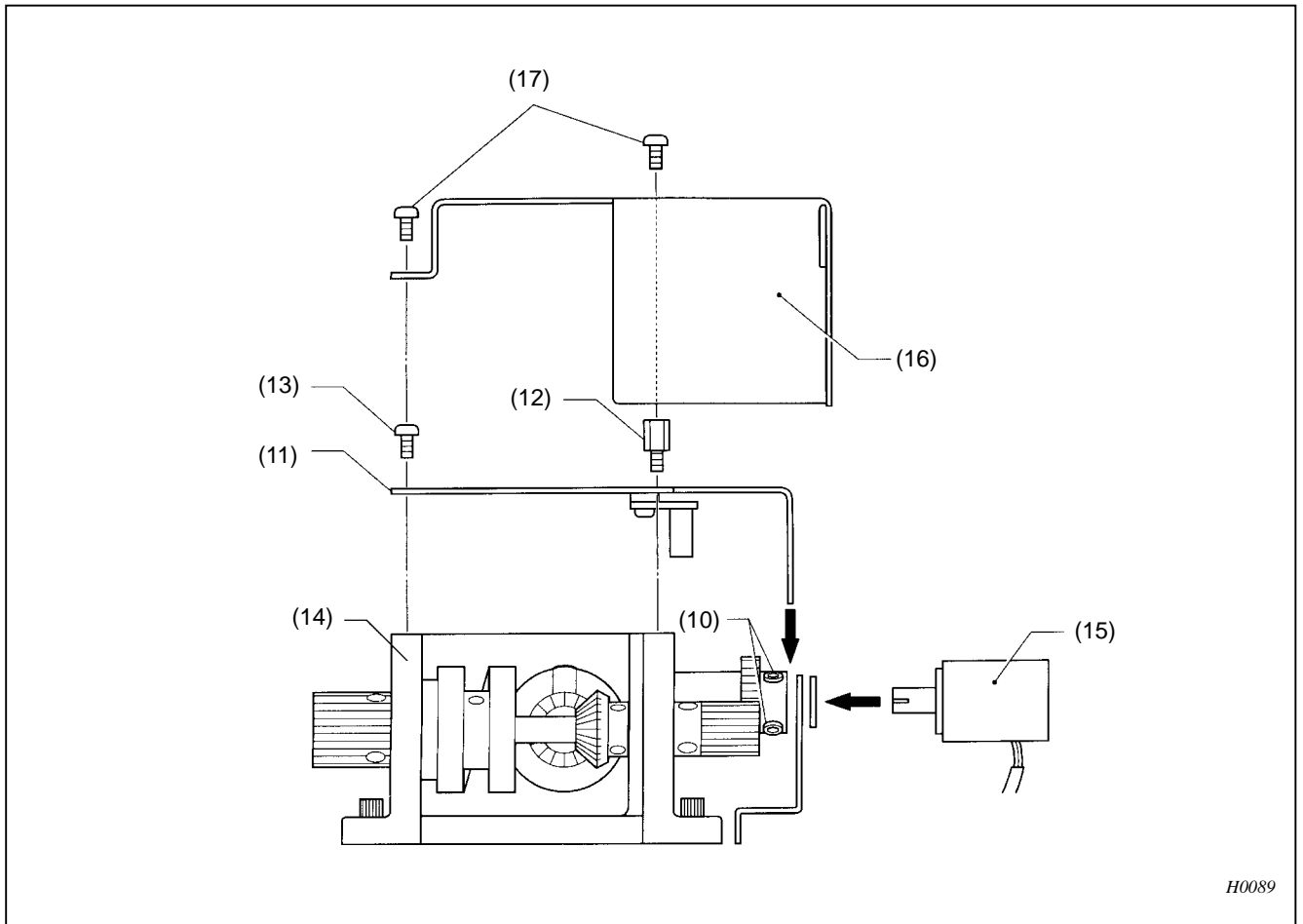

7. Attach the base (11) to the change box (14) using the two spacer (12) and screw (13).



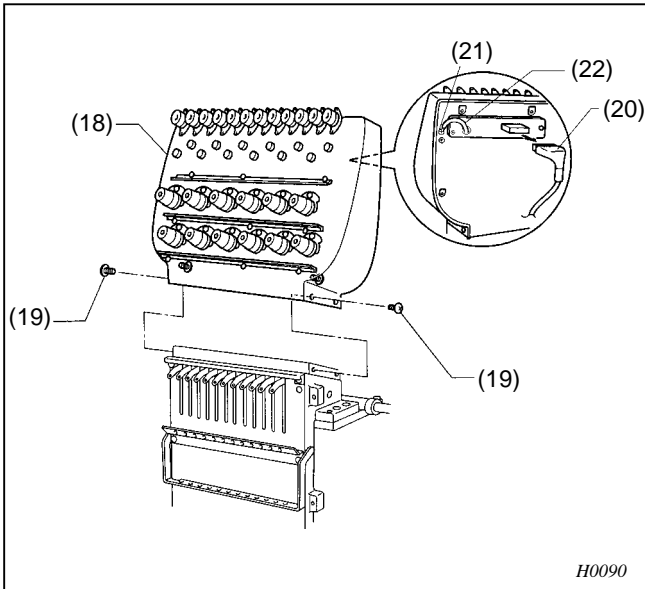

8. Attach the reduction gear B (10) to the potentiometer (15) with the set screws.

9. Set the change box cover (16) over the change box (14), with the screw (17).



10. Attach the adjustment base (18) using the four screws (19) and insert connector (20) into the rear of the adjustment base (18).
11. Attach the earth cable (22) using the screw (21).

4. Adjustment

 CAUTION	
	Turn off the power switch and disconnect the power cord from the wall outlet at the following times, otherwise the machine may operate if the start switch is pressed by mistake, which could result in injury.
	If the power switch needs to be left on when carrying out some adjustment, be extremely careful to observe all safety precautions.
	Maintenance and inspection of the sewing machine should only be carried out by a qualified technician.

4-1. Adjusting the needle bar height(BES-116AC, 916AC, 1216AC)

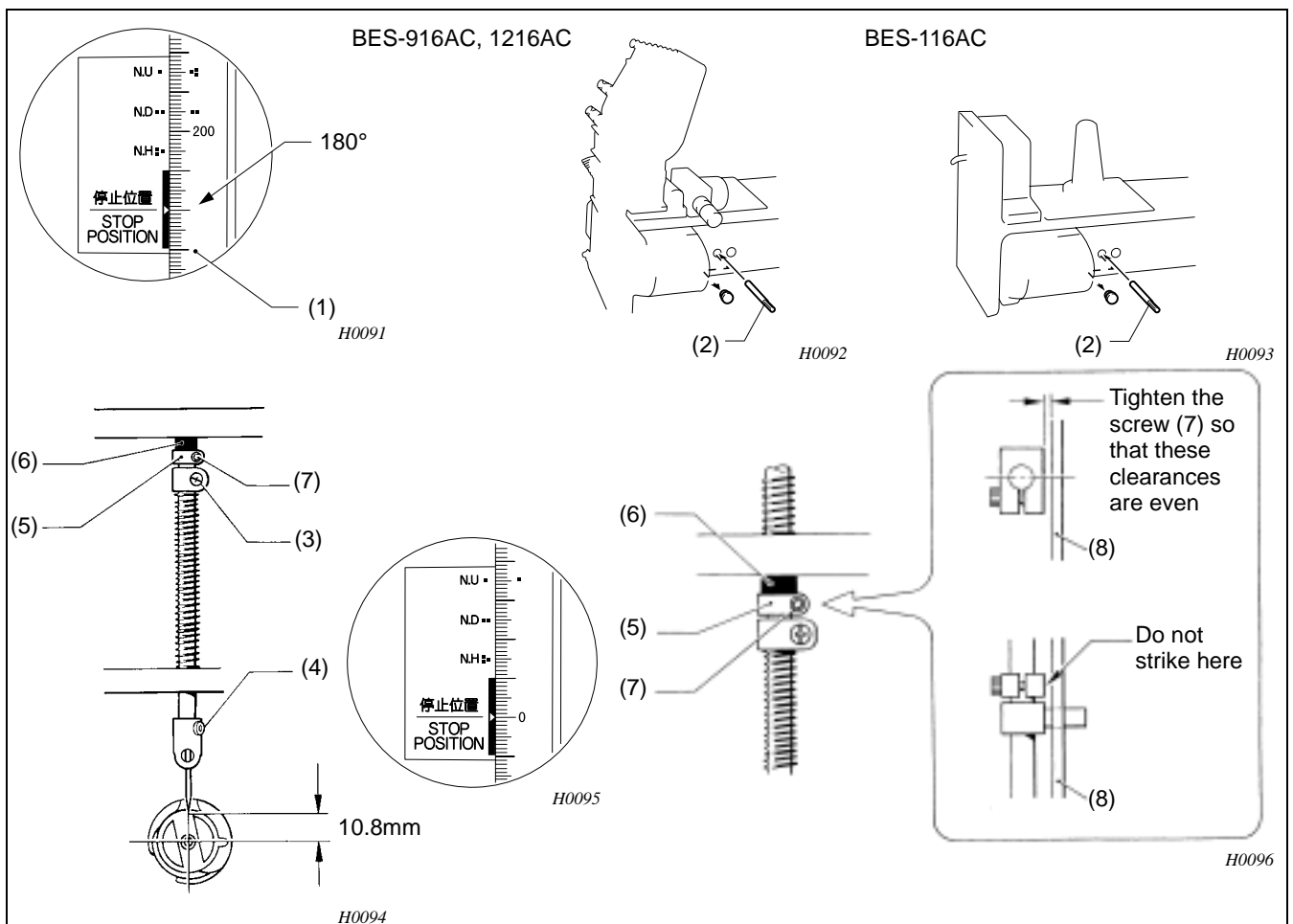

1. Turn the pulley (1) to set the needle bar to its lowest point. (Turn the pulley until ■■ mark on the pulley is aligned with the one on the belt cover.)
2. Insert the positioning bar (2) into the hole in the side of the machine head, and secure the upper shaft.

(NOTE) Turn the pulley tightly to the proper direction of rotation because it is easy to rattle.

-
3. Loosen the screw of the needle bar clamp (3) when the needle tip is positioned 10.8 mm above the center of the rotary shaft. Adjust the position of the needle bar thread guide so that the set screw (4) on it is turned 25° – 30° degrees to the right when viewed from the front. Tighten the screw of the needle bar clamp (3).
(NOTE) When tightening the screw of the needle bar clamp, the hole in the needle bar thread guide should face the front.
 4. Set the needle bar to its highest point. Lightly press the top dead center stopper (5) toward the cushion rubber (6), and tighten the bolt (7) so that it faces the front.
(NOTE) Make sure that the stopper does not strike the needle bar guide rail.
(NOTE) The movement of the needle bar may become slow and stiff when the screw of the top dead center stopper is over torqued.
 5. Remove the positioning bar (2) from the machine head.

4-2. Adjusting the timing between the needle and the rotary hook [when the needle bar is raised 2mm] (BES-116AC, 916AC, 1216AC)

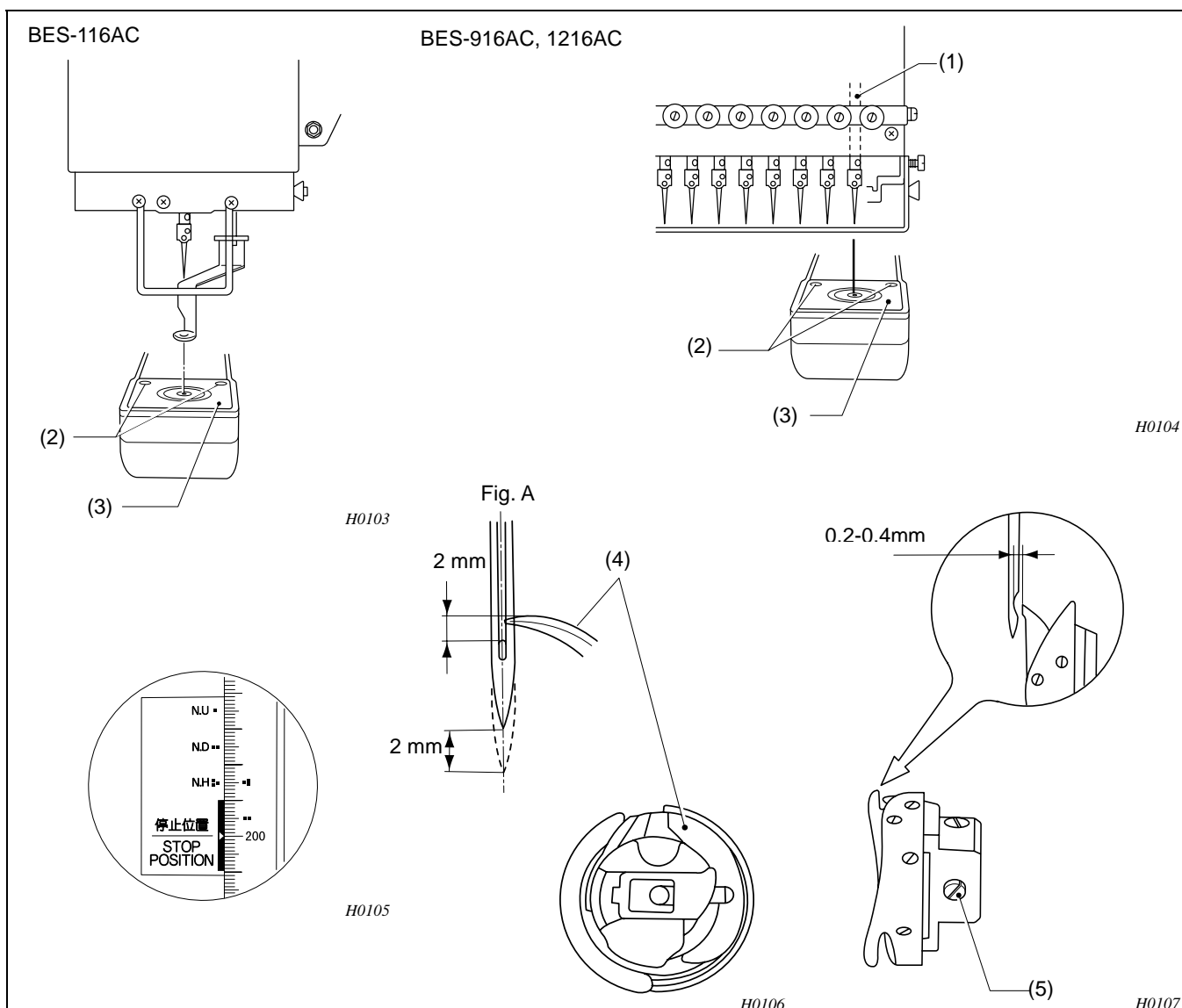

1. Select the first needle bar (1) (for the BES-916AC and 1216AC).
2. Remove the two screws (2), and the needle plate (3).
3. Loosen the set screw (5) of the rotary hook, and adjust the rotary hook (4) position so that there is a 0.2-0.4 mm clearance between the needle and the rotary hook point. Then tighten the two set screws. At this time, the needle bar will be raised 2 mm above its lowest position (as shown in figure A), and the ■■ mark on the pulley will be aligned with the one on the belt cover.
4. Make sure that the clearance between the needle and the rotary hook is 0.2-0.4 mm. Then tighten the three set screws (5) of the rotary hook.

(NOTE) For the BES-916AC and 1216AC

If the clearance between the needle and the rotary hook is not 0.2-0.4 mm, repeat step 3, and make sure that there is a 0.2-0.4 mm clearance between the needle and the rotary hook at both the first and ninth needle bars.

4-3. Adjusting the presser foot height(BES-116AC, 916AC, 1216AC)

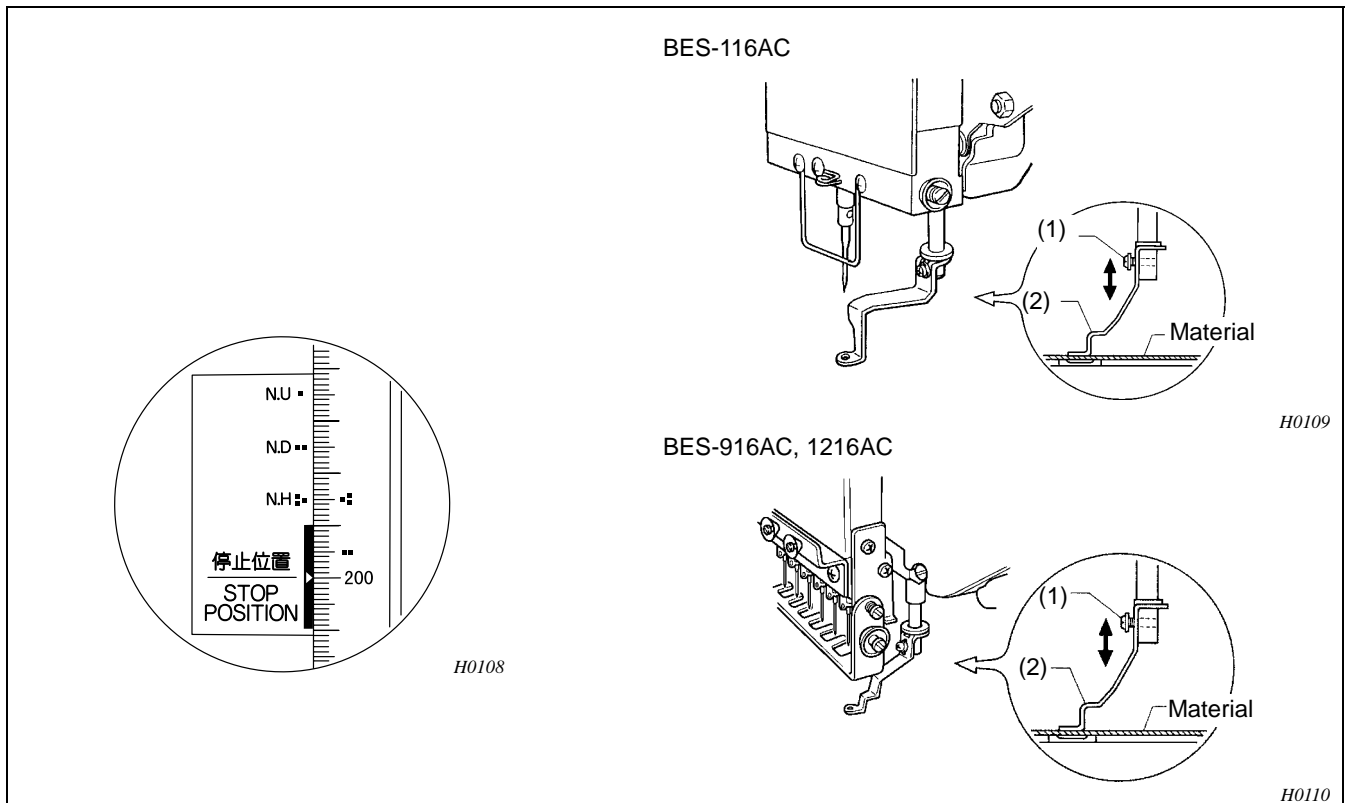

Adjust the presser foot (1) height by loosening the screw (2) so that the presser foot is above the material when the former is in its lowest position (when ■■ mark on the pulley is aligned with the one on the belt cover).

(NOTE) Select the first needle bar, and loosen the screw of the presser foot.
(BES-916AC, 1216AC)

(NOTE) While the power is turned on, lower the presser foot using the presser retracting lever.

Adjusting the position of the presser shaft

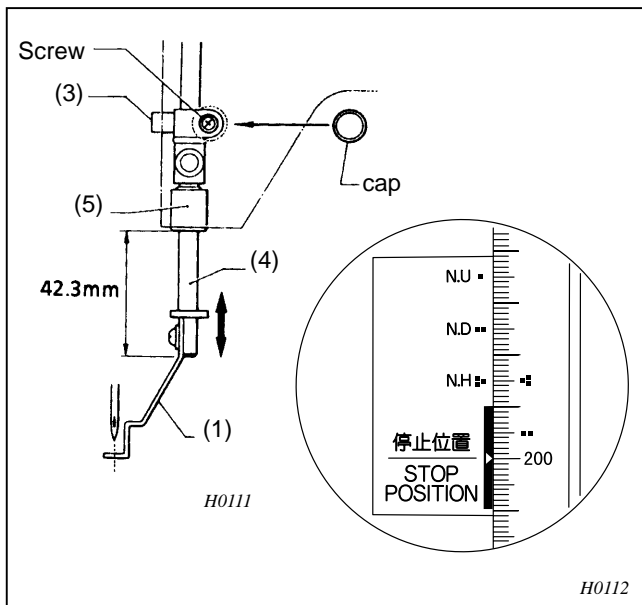

1. Turn the pulley to set the presser foot to its lowest position. (Turn the pulley until ■■ mark on the pulley is aligned with the one on the belt cover.)
2. Loosen the screw of the presser shaft clamp (3) using a screwdriver inserted through the hole in the side of the machine head. Adjust the position of the presser shaft (4) so that the distance from the end of the bush (5) to the end of the presser shaft (4) is 42.3 mm.
3. Securely tighten the screw of the presser shaft clamp (3).
4. Make sure that the needle is inserted into the center of the hole in the presser foot (1) when it is lowered.

4-4. Adjusting the spring

BES-116AC

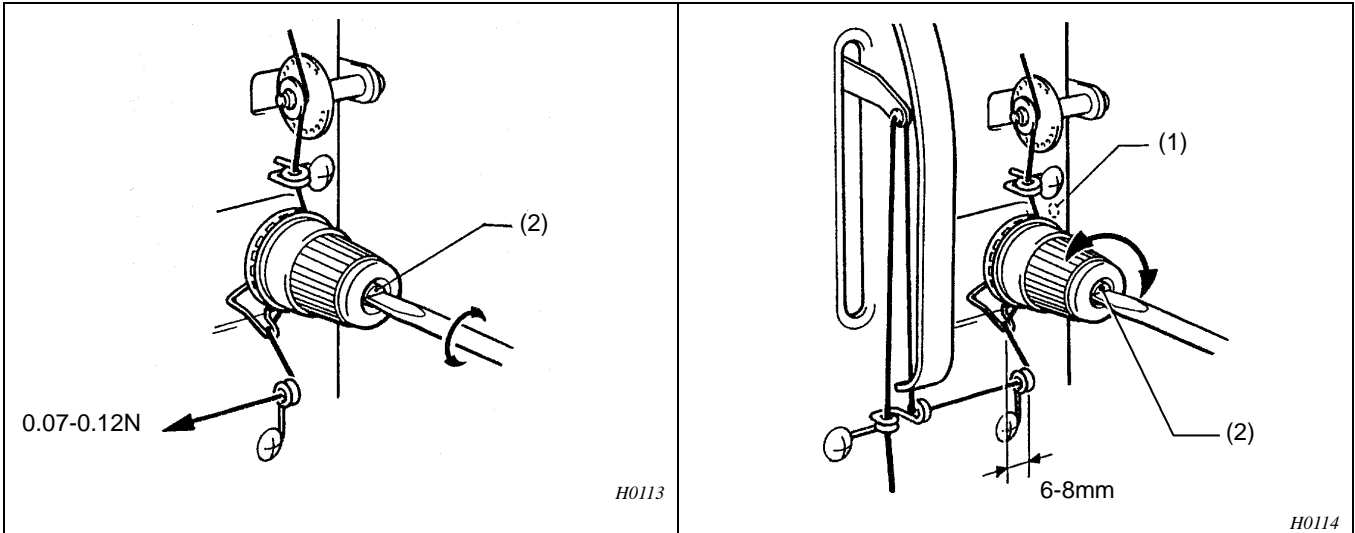

(MEMO) The standard operation range of the thread take-up spring is about 6-8 mm. The standard tension at this time is about 0.07N-0.12N.

1. To adjust the operation range of the thread take-up spring, loosen the screw (1), and turn the upper thread tension assembly.
2. To adjust the tension of the thread take-up spring, fit a screwdriver into the slot, and turn the tension stud (2) as appropriate.

BES-916AC, 1216AC

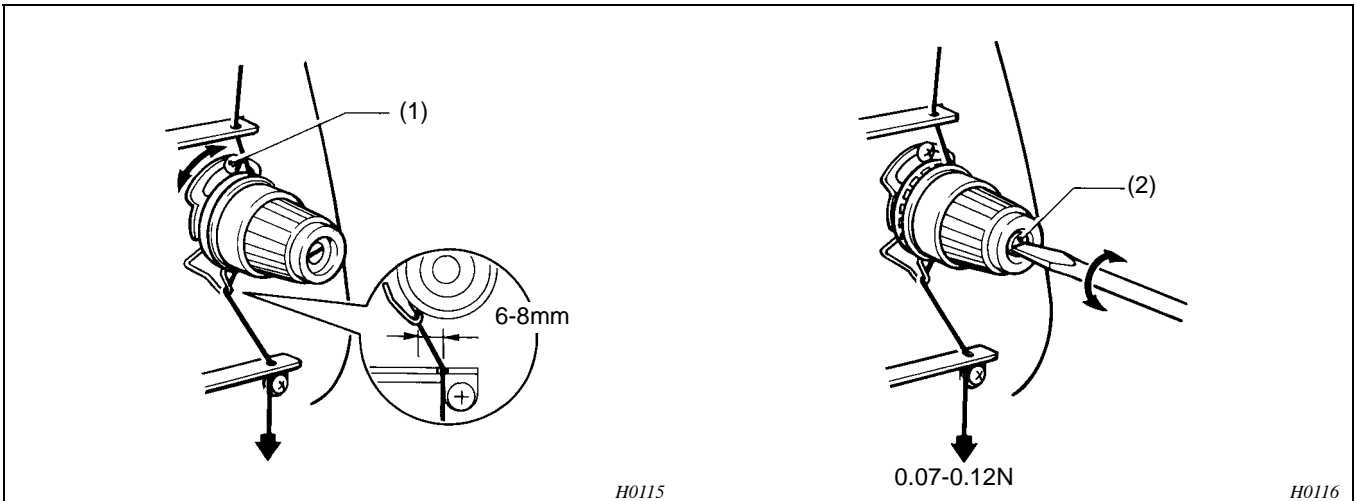

(MEMO) 6-8 mm in height The tension spring should be adjusted to and 0.07-0.12N in force.

1. For adjusting the height, loosen the screw (1) and turn the tension spring bracket (2).
2. For adjusting the tension spring force, insert a driver tip in the groove of the thread tension stud (3) and turn it.

(NOTE) The standard needle thread tension is 0.69N-1.27N(When # 120 thread is used).

(NOTE) It is necessary to adjust the needle thread tension according to the material thickness. Adjust the spring applied force as well as the needle thread tension.

4-5. Adjusting the picker (BES-116AC, 916AC, 1216AC)

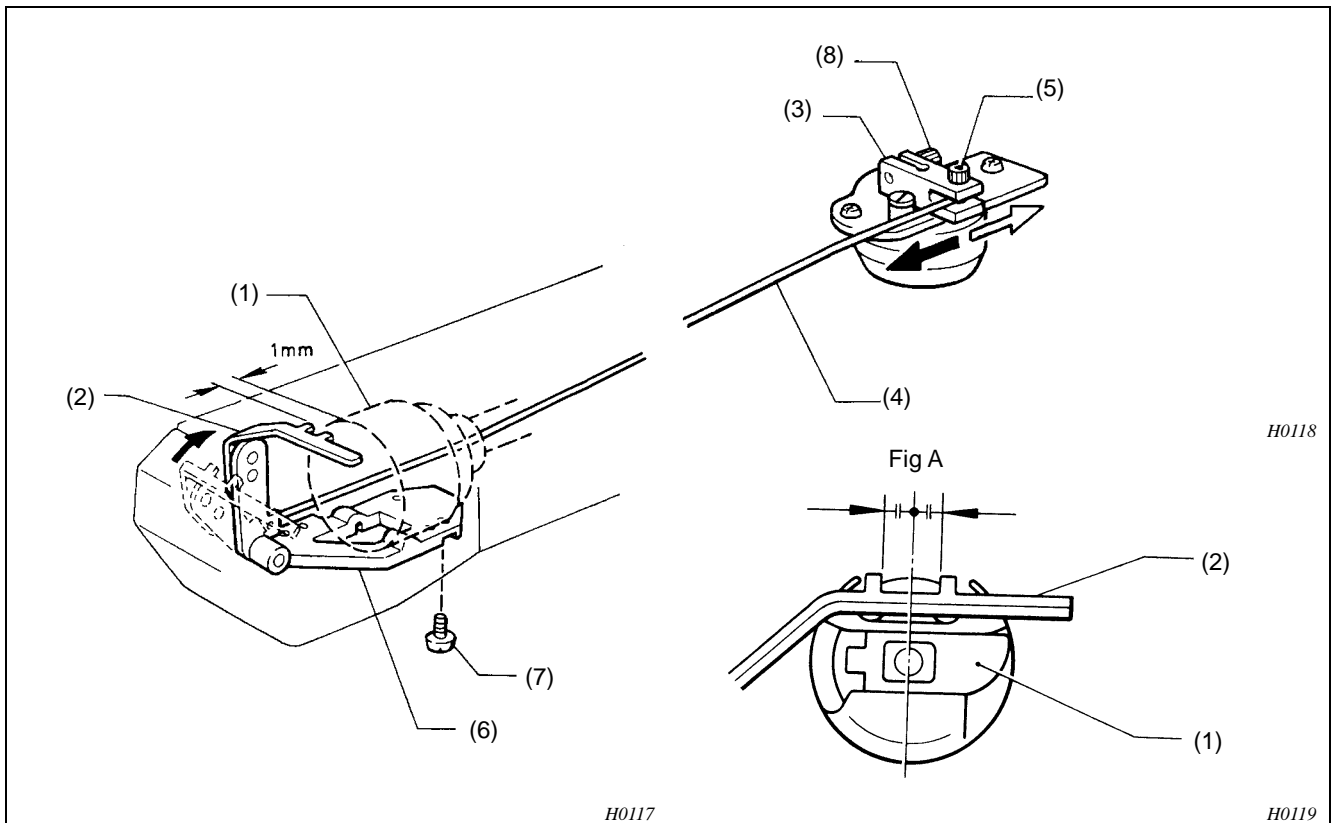

1. Insert the bobbin case (1) containing the bobbin into the rotary hook, and set the picker (2) position.
2. Leave the solenoid arm (3) pushed to the needle bar side, and secure the connecting wire (4) using the screw (5).
3. Secure the picker bracket (6) using the screw (7) so that the picker (2) moves easily without any play.
4. Set the clearance between the end of the picker (2) and the bobbin to 1 mm, leave the solenoid arm (3) pushed to the pulley side (leave the solenoid operated), and tighten the screw (8).
5. Adjust position of the picker (2) so that it is centered in the bobbin case (1).

(NOTE) When the picker is retracted (the solenoid is turned off), there should be a 17 mm clearance between the bobbin and the tip of the picker.

4-6. Adjusting the clearance between the rotary hook and the inner rotary hook stopper (BES-116AC, 916AC, 1216AC)

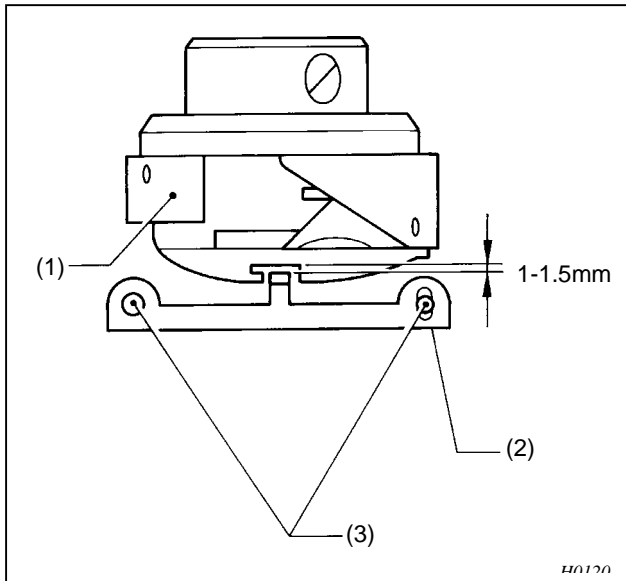

1. The clearance between the rotary hook (1) and the inner rotary hook stopper (2) should be enough to pass the thread through the clearance easily.
2. Loosen the two screws (3) to adjust the clearance between the rotary hook and the inner rotary hook stopper to 1-1.5 mm.
3. Lower the needle. Make sure that the inner rotary hook stopper (2) is inserted into the center of the groove of the rotary hook (1).

4-7. Adjusting the movable knife and the fixed knife (BES-116AC, 916AC, 1216AC)

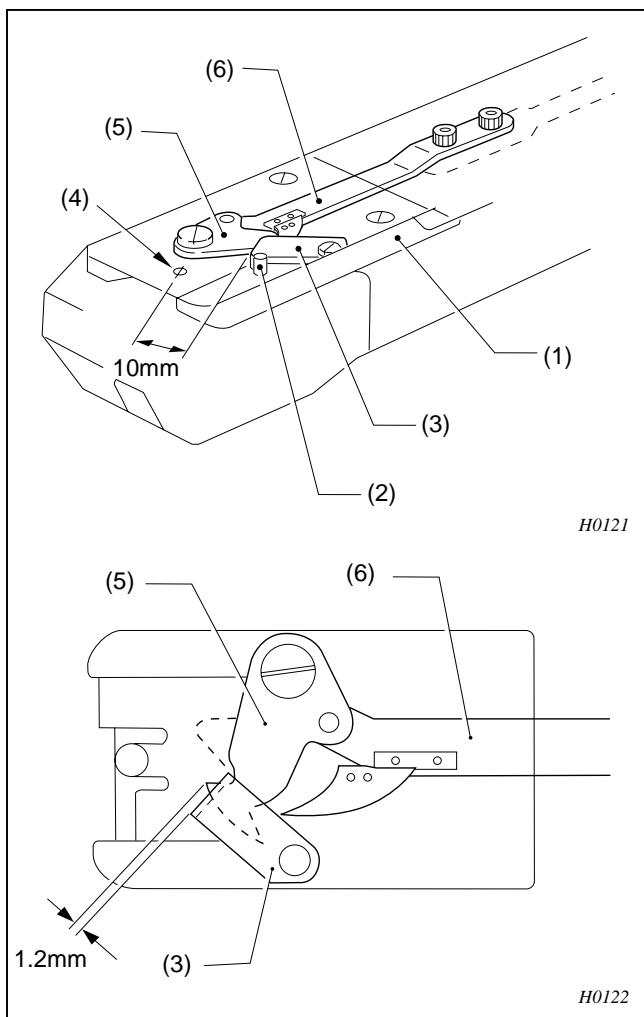

Attaching the fixed knife

Attach the fixed knife (3) to the spring roll pin (2) of the needle plate bracket (1) using the screw.

The fixed knife (3) should be positioned so that it is 10 mm from the hole (4) in the needle plate.

Movable knife position

The movable knife (5) always should be positioned so that it is projected 1.2 mm from the fixed knife (3).

Adjust the position of the movable knife (5) using the thread trimmer connecting rod (6) so that it is the same as after thread trimming.

4-8. Adjusting the thread wiper (BES-916AC, 1216AC)

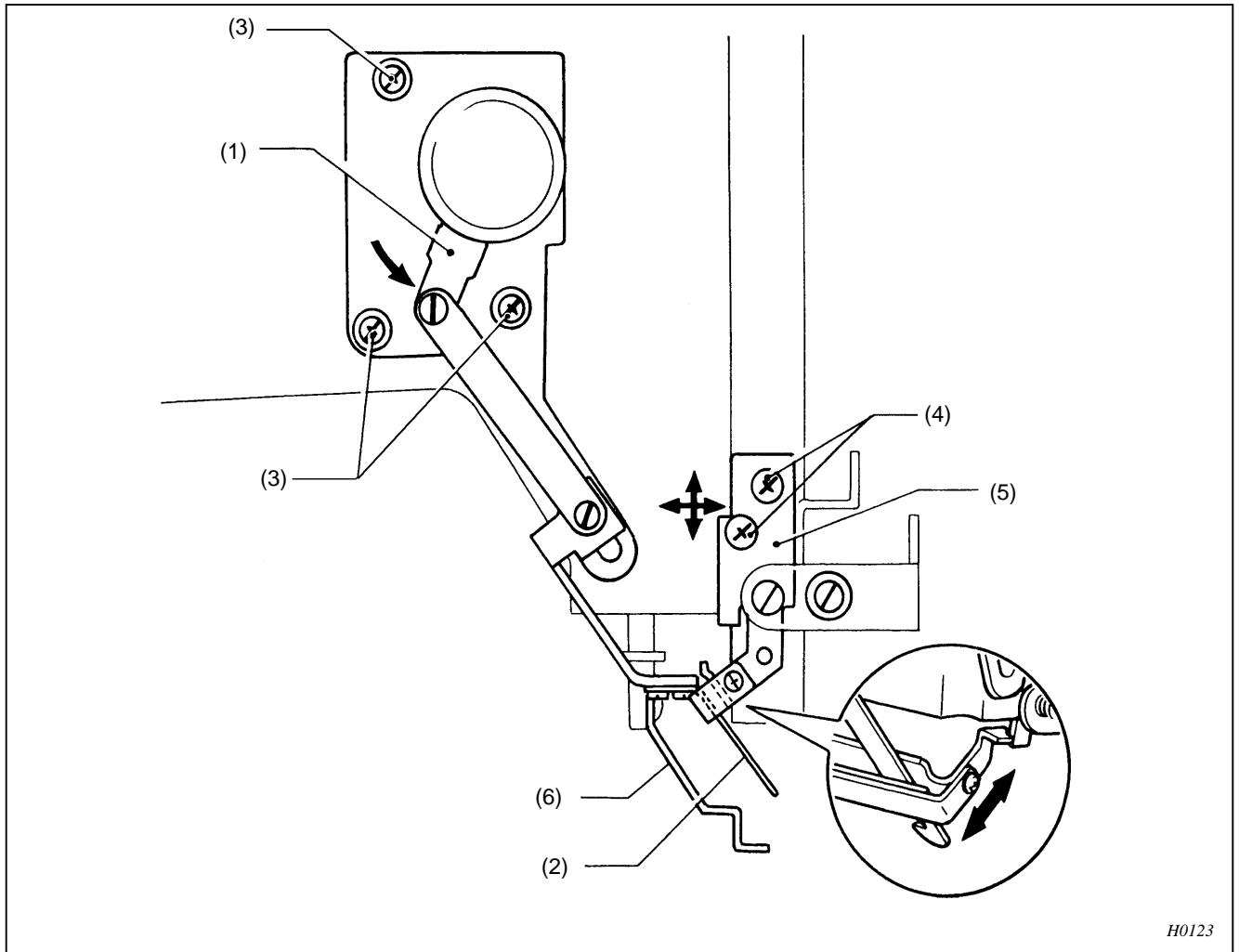

H0123

1. Move the solenoid arm (1) in the direction of the arrow with your finger. Loosen the three screws (3), and adjust the upper thread guard hook (2) so that it moves easily.
2. If the first and ninth (BES-1216AC No.12) needles operate differently, loosen the four screws (4), move the thread presser base (5) in the direction of either axis (as indicated), and adjust their positions, provided that the presser foot (6) does not hit the needle when raised by the solenoid.

4-9. Adjusting wire tension (BES-116AC, 916AC, 1216AC)

4-9-1. X-feed wire

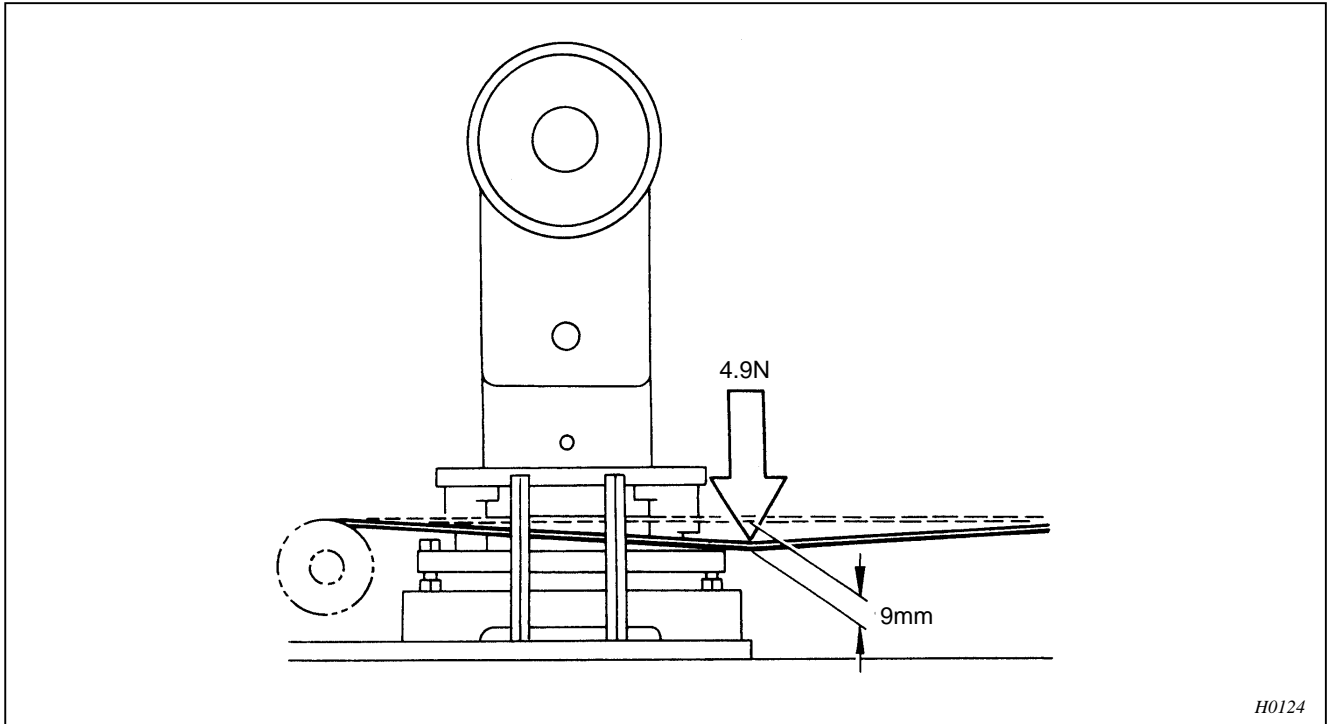

Pushing by 4.9N torque wrench or similar tool at the point illustrated above by the arrow, adjust so there is a deflection of approximately 9 mm.

How to adjust

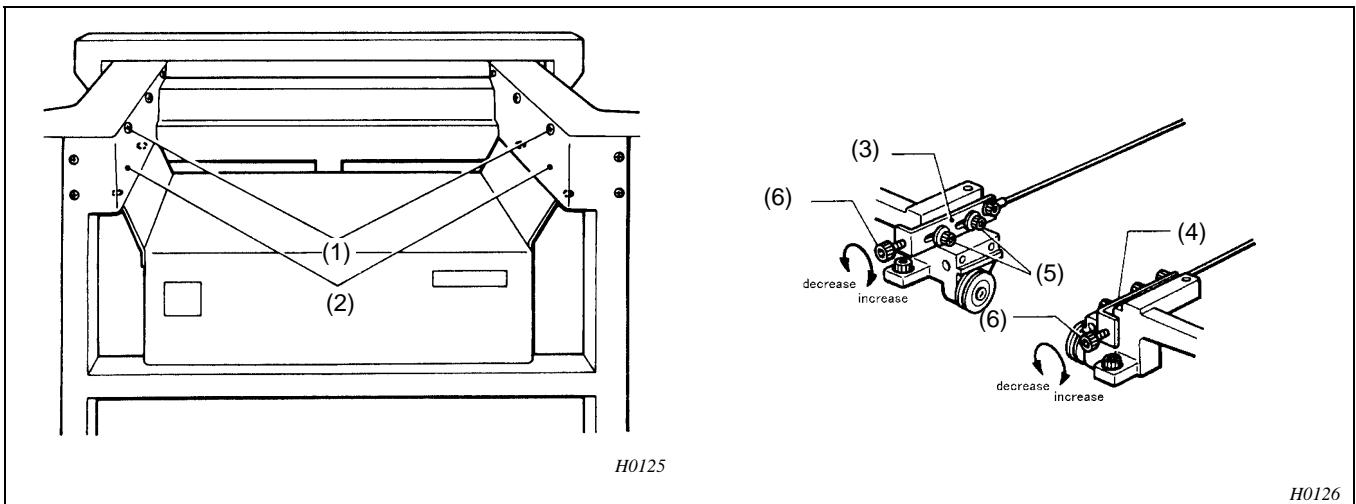

1. Remove the seven screws (1) and the two covers (LR, LL) (2).
2. Loosen the two bolts (5) of both hook (LX) (3) and hook (RX) (4).
3. There are two bolts (6) on the right and the left sides. Turning them clockwise will increase the tension and turning them counterclockwise will decrease the tension.
4. When the tension is proper, tighten bolts (5).
5. Firmly retighten bolt (5) so there is no looseness.

4-9-2. Y-feed wire

Pushing by 4.9N torque wrench or similar tool at the center point of wires, adjust so there is a deflection of approximately 13 mm.

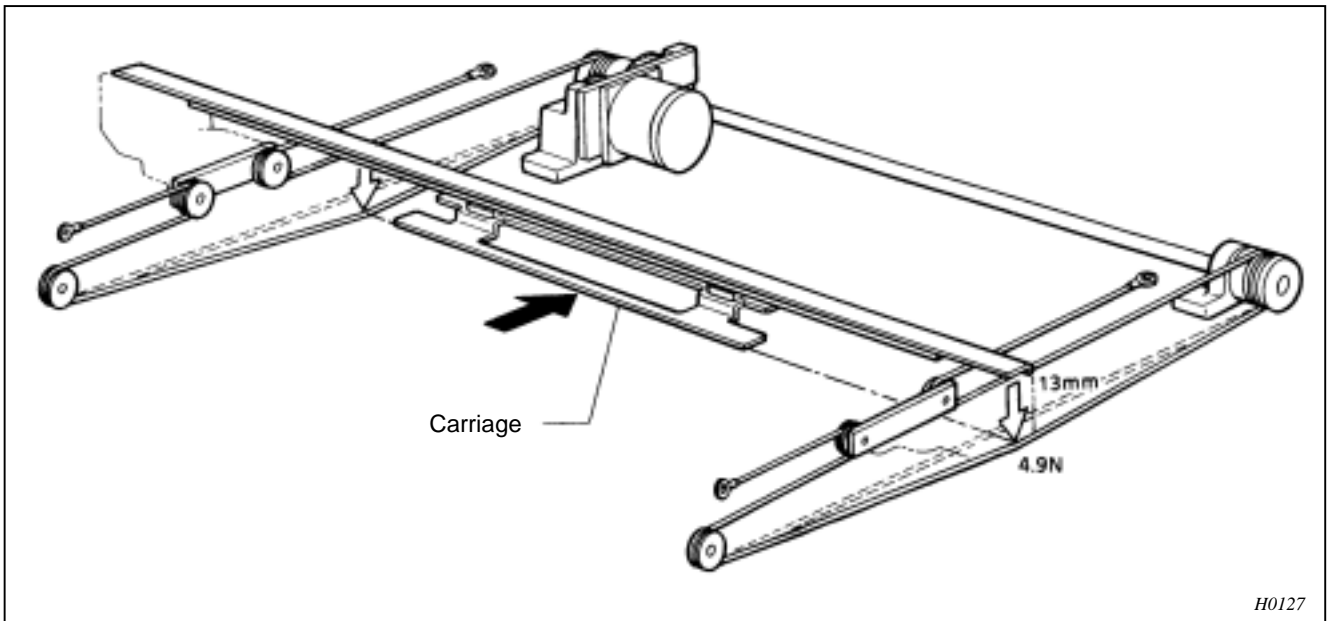

How to adjust

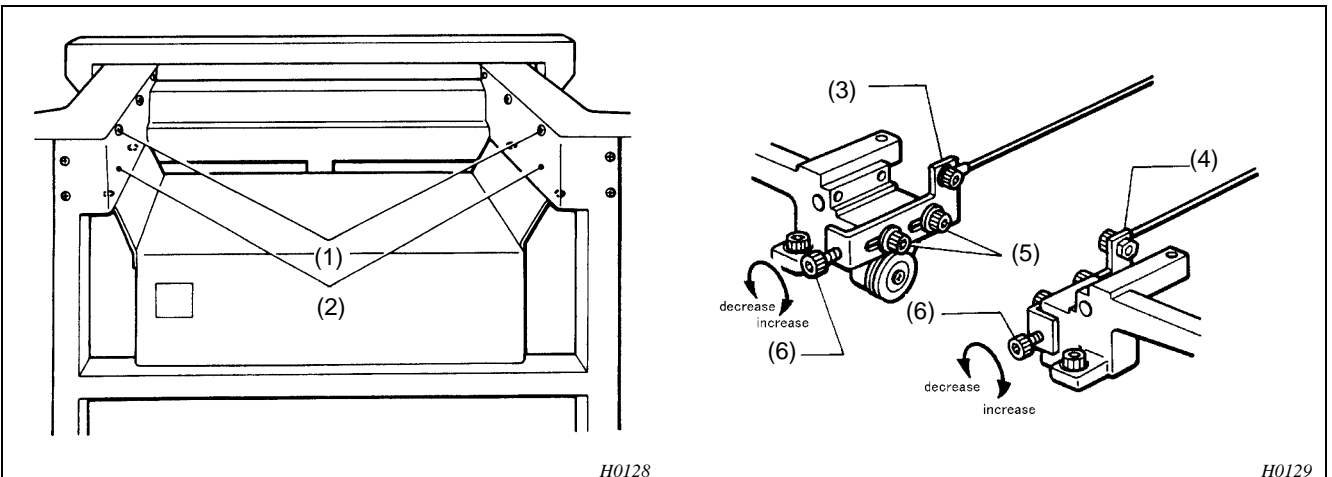

1. Remove the seven screws (1) and the two covers (LR, LL) (2).
2. Loosen the two bolts (5) of both hook (LY) (3) and hook (RY) (4).
3. There are two bolts (6) on the right and the left sides. Turning them clockwise will increase the tension and turning them counterclockwise will decrease the tension.
4. When the tension is proper, tighten bolts (5).
5. Firmly retighten bolt (5) so there is no looseness.

4-10. Adjusting the thread trimmer cam (BES-116AC, 916AC, 1216AC)

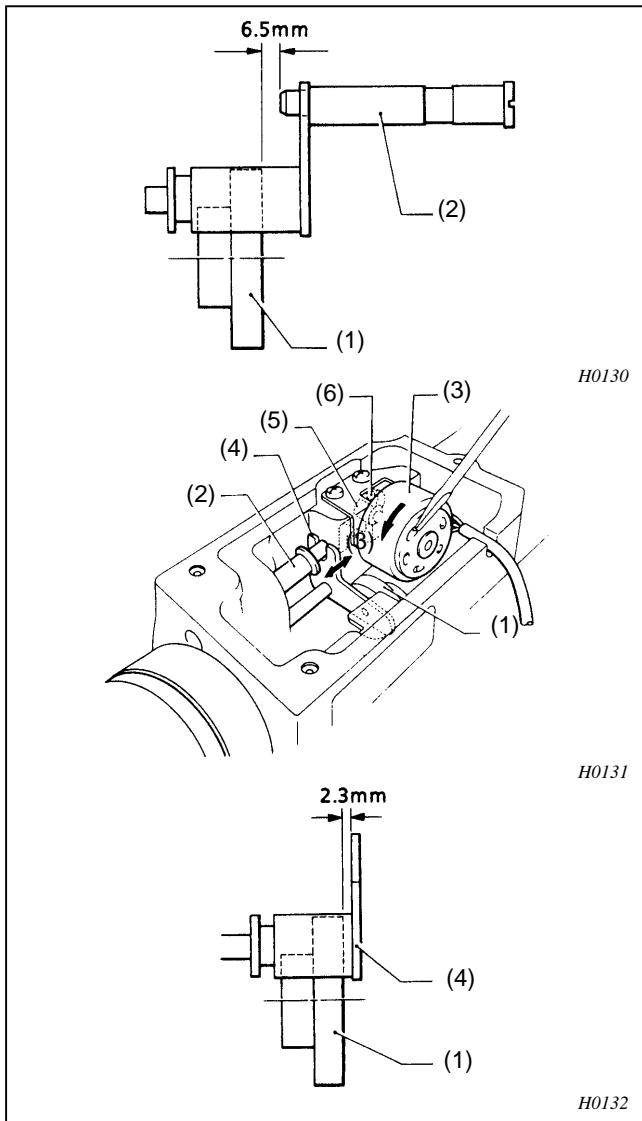

1. The clearance between the edge of the thread trimmer cam (1) and the edge of the positioning shaft (2) is 6.5 mm.
2. While pressing the rotating part of the thread trimmer solenoid (3) toward the solenoid using a screwdriver, turn the former to set it at the end of the stroke. Loosen the screw (6) of the solenoid lever (5), and move the thread trimmer driving lever (4) back and forth to adjust the clearance from the end of the thread trimmer cam (1) to the end of the thread trimmer driving lever (4) to 2.3 mm.
3. Securely tighten the screw (6) of the solenoid lever (5).

Adjusting the positioning shaft

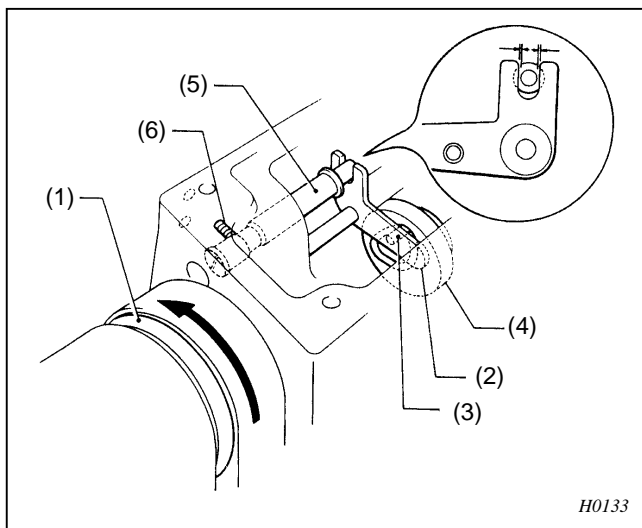

Turn the pulley (1) manually until the roller (3) of the thread trimmer driving lever (2) is inserted into the groove of the thread trimmer cam (4) to trim the thread. Loosen the set screw (6) in the side of the machine head, adjust the positioning shaft (5) by turning it using a screwdriver so that the groove of the thread trimmer driving lever (2) is easily inserted into the positioning shaft (5).

(NOTE) The positioning shaft is eccentric. Adjust the positioning shaft so that it is positioned above the groove of the thread trimmer driving lever.

4-11. Adjusting the thread sensor (BES-116AC)

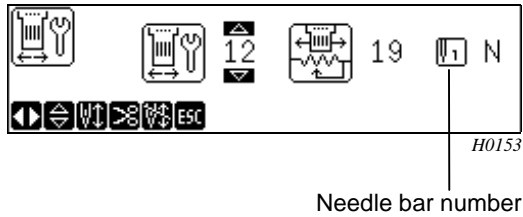

- Select the needle bar moving test mode.

- To turn the thread trimmer detect pulley (1), the needle bar number on screen will blink.

Loosen screw (3) of the thread breakage sensor plate (2). Turn the thread trimmer detect pulley (1) manually, and move the thread breakage sensor plate (2) in the direction of the arrow to adjust its position so that the buzzer will beep.

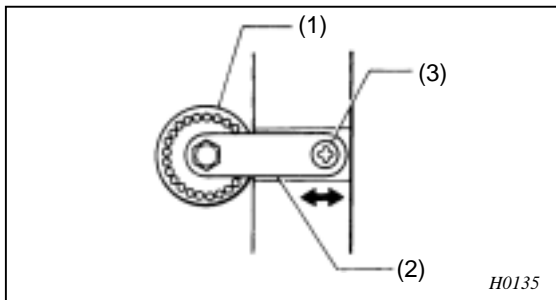

Press the <ESC> key to return to the port selection menu.

4-12. Adjusting the wire of the cap frame device (BES-116AC, 916AC, 1216AC)

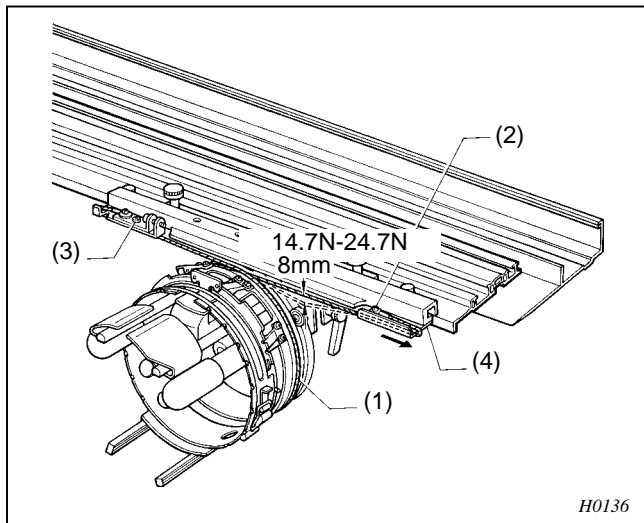

1. Loosen the screw (3), and adjust the wire tension by tightening the screws (2) so that the wire is equally pulled at each end. After adjustment, tighten the screw (3).
2. Shift the wire base (4) to one side.
3. Adjust the wire tension by tightening the screws so that the slack will be 8 mm with a load of 14.7-24.7N applied to the middle of the wire (1).

4-13. Replacing an adjusting the potentiometer assembly (BES-916AC, 1216AC)

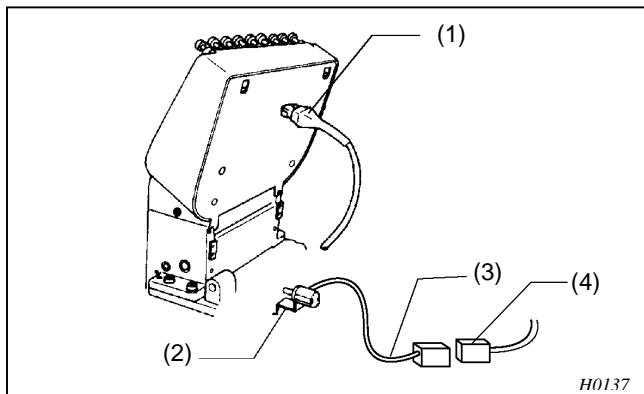

1. Connect the thread tension bracket harness connector (1) to the connector on the rear side of the thread tension bracket circuit board. Connect the connector (3) of the potentiometer (2) to the trunk cable (4).
(NOTE) Remove the potentiometer (2) from the sewing machine, and you can manipulate the knob on it by your hand.

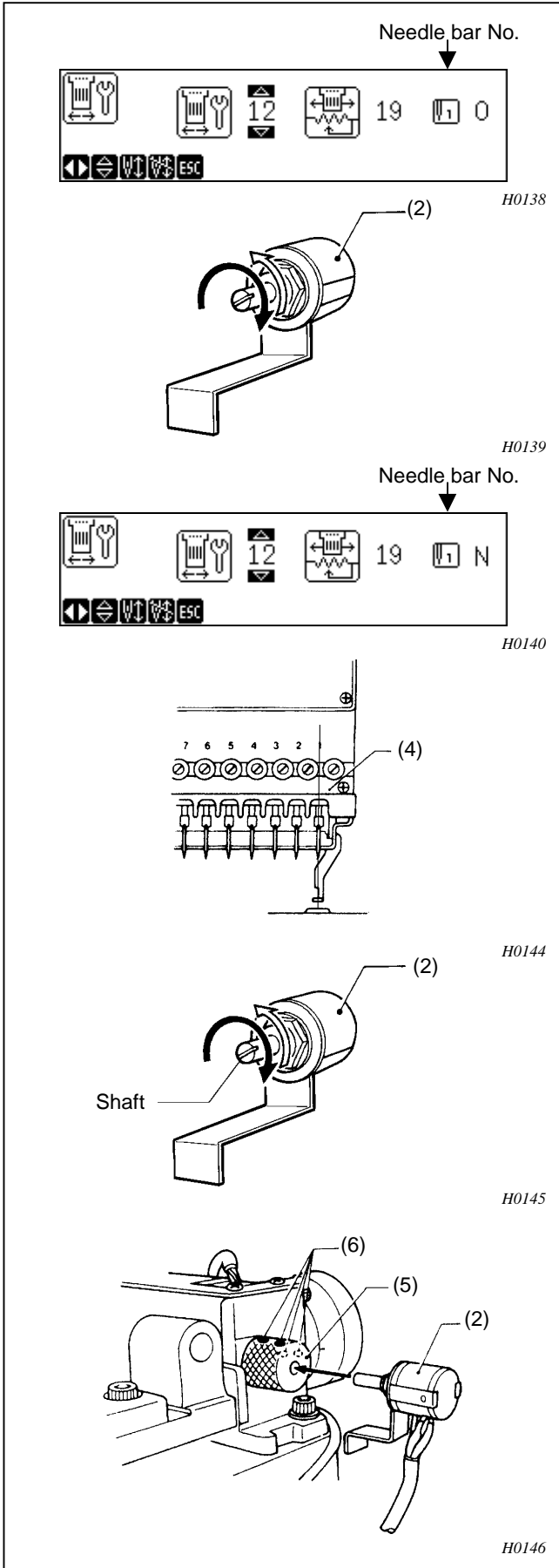

2. Turn on the power of the machine.
3. The machine starts the needle bar moving test in the test mode. Refer to "Test Mode" in chapter 4.
4. Turn the potentiometer (2) all the way to the right as shown in the illustration to the left. When it is then turned gently to the left the buzzer on the operation panel sounds.
5. The point where the buzzer sounds is the potentiometer (2) position for the first stitch. The operation panel will be displayed as shown in the illustration to the left at this time.
 "N" is shown on the right of 1, "19" is shown on the left.
6. Move the needle bar case (4) to the neutral position turn the reduction gear (5) (the position where the needle bar case (4) does not move).
7. In this condition, insert the shaft of the potentiometer (2) into the reduction gear (5) so that it does not move, and secure by tightening the set screw (6).
8. Check that the needle bars match the numbers in the display (No.1 to No.9) when the keys are used to move the needle bar case (4).
9. Once the operation has been checked and is okay, securely tighten the potentiometer (2) set screws (6).

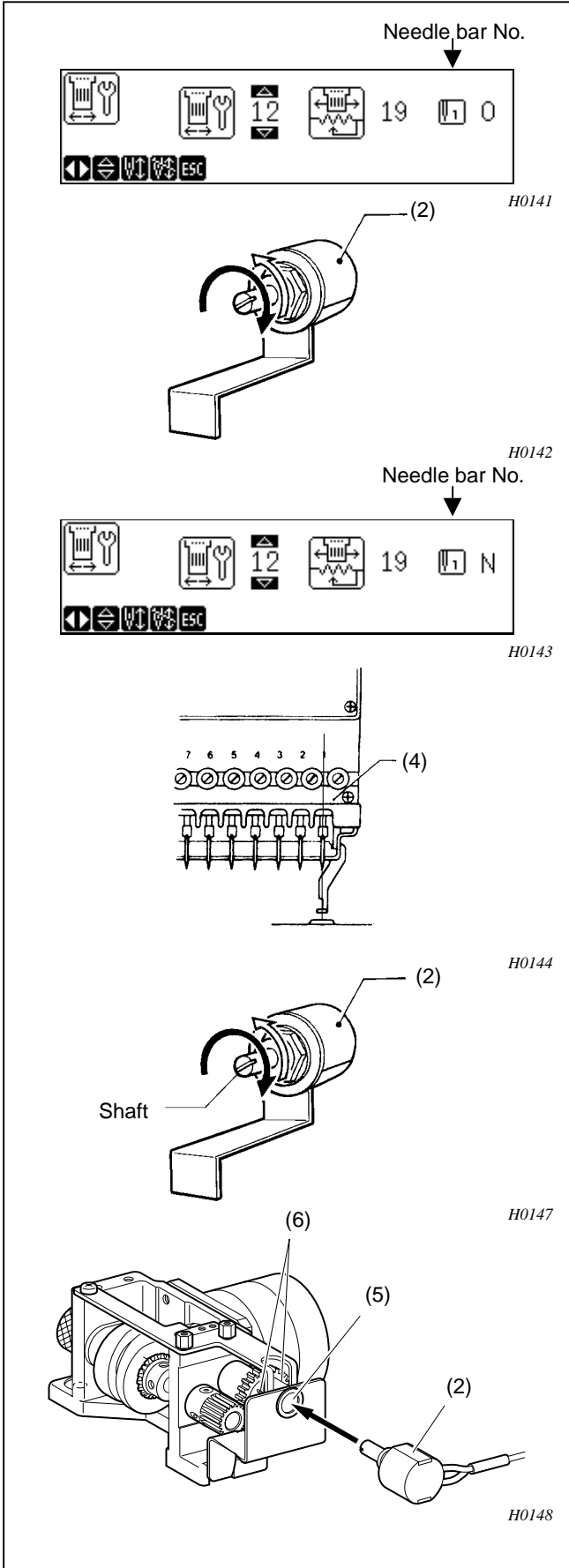

2. Turn on the power of the machine.
3. The machine starts the needle bar moving test in the test mode. Refer to "Test Mode" in chapter 4.
4. Turn the potentiometer (2) all the way to the left as shown in the illustration to the left. When it is then turned gently to the right, the buzzer on the operation panel sounds.
5. The point where the buzzer sounds is the potentiometer (2) position for the first stitch. The operation panel will be displayed as shown in the illustration to the left at this time.
 "N" is shown on the right of 1, "19" is shown on the left.
6. Move the needle bar case (4) to the neutral position turn the reduction gear (5) (the position where the needle bar case (4) does not move).
7. In this condition, insert the shaft of the potentiometer (2) into reduction gear (5) so that it does not move, and secure by tightening the set screw (6).
8. Check that the needle bars match the numbers in the display (No.1 to No.9) when the keys are used to move the needle bar case (4).
9. Once the operation has been checked and is okay, securely tighten the potentiometer (2) set screws (6).

4-14. Adjusting the bobbin winder (BES-116AC, 916AC, 1216AC)

4-14-1. Positioning the bobbin winder claw

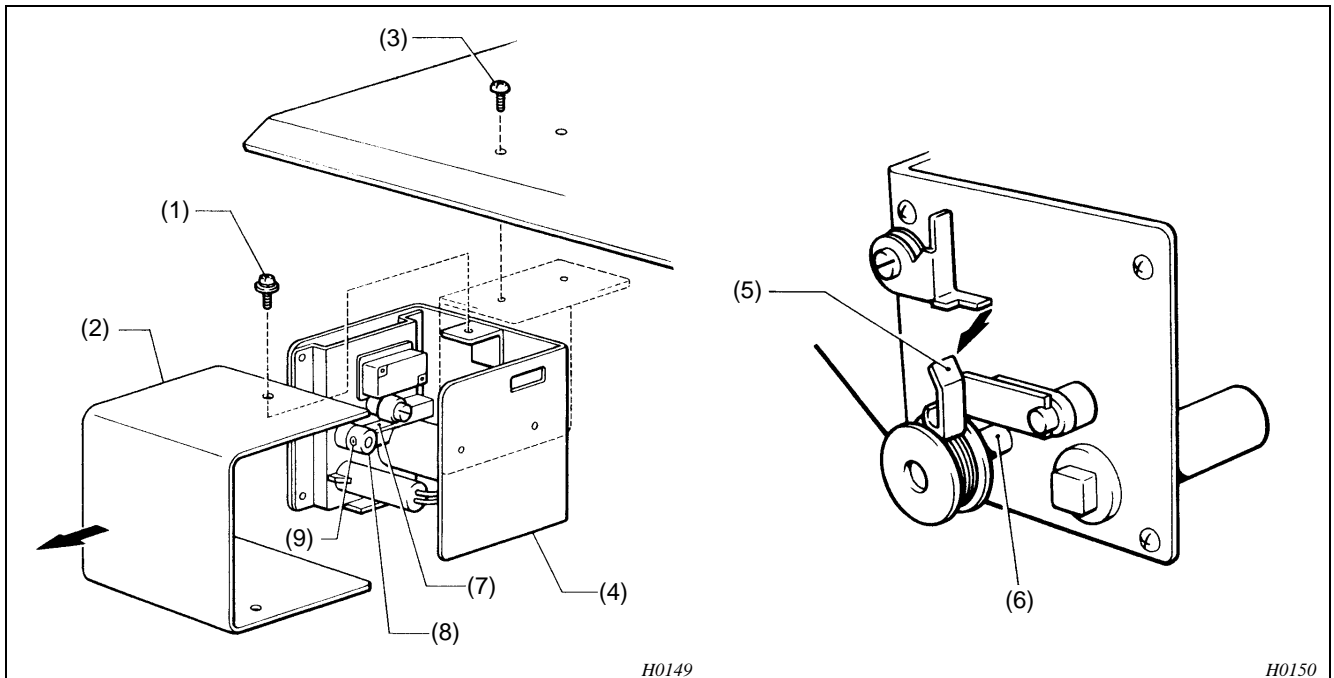

1. Remove the three screws (1), and the bobbin winder cover (2).
Remove the two screws (3), and the bobbin winder assembly (4).
2. Move the bobbin presser (5) toward the bobbin winder shaft (6) just before it reaches the position where thread winding ends.
3. Tighten the two screws (9) so that the plate spring (7) is at the stepped section of the bobbin winder claw (8).

4-14-2. Positioning the bobbin presser

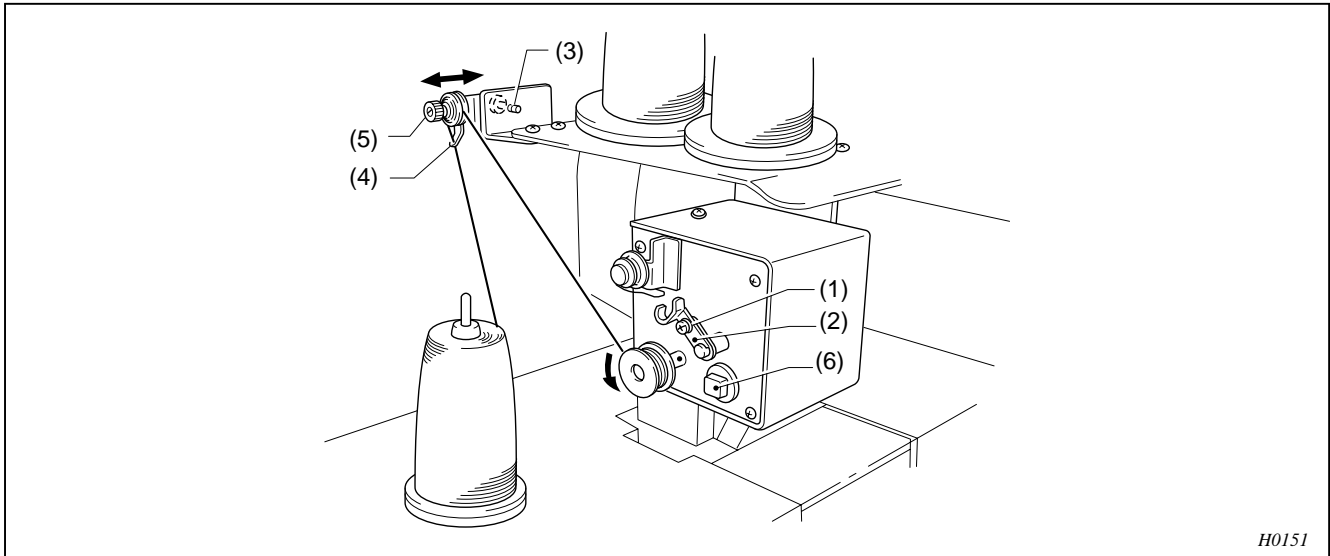





Loosen the screw (1), and adjust the bobbin presser (2) by moving it so that the proper amount of thread can be wound on the bobbin.

- (NOTE) If the thread is not wound evenly on the bobbin, loosen the screw (3) and move the thread guide (4) right and left. When winding more thread on the bobbin, loosen the screw (1), then move the bobbin presser (2).
- (NOTE) If the thread comes out from the thread guide (4), loosen the knob (5). If the thread is wound too loose, tighten the knob (5).
- (NOTE) The thread winder motor does not operate if the circuit protector activated. In that case, leave the protector until it's cooled off. Then, press the protector switch (6). (If the protector is not cooled off, the switch does not work.)

5. Test Mode

5-1. Entering into the test mode

1. Press the  key twice on the embroidery initial screen.
2. Select the  icon with the ◀ or ▶ jog key and press the  key.
3. Input “961” as the password and press the  key.

5-2. Selecting the test mode menu

There are the following three modes among the test mode.

Select each icon with the ◀ or ▶ jog key and press the  key.

The menus for each mode are as follows:

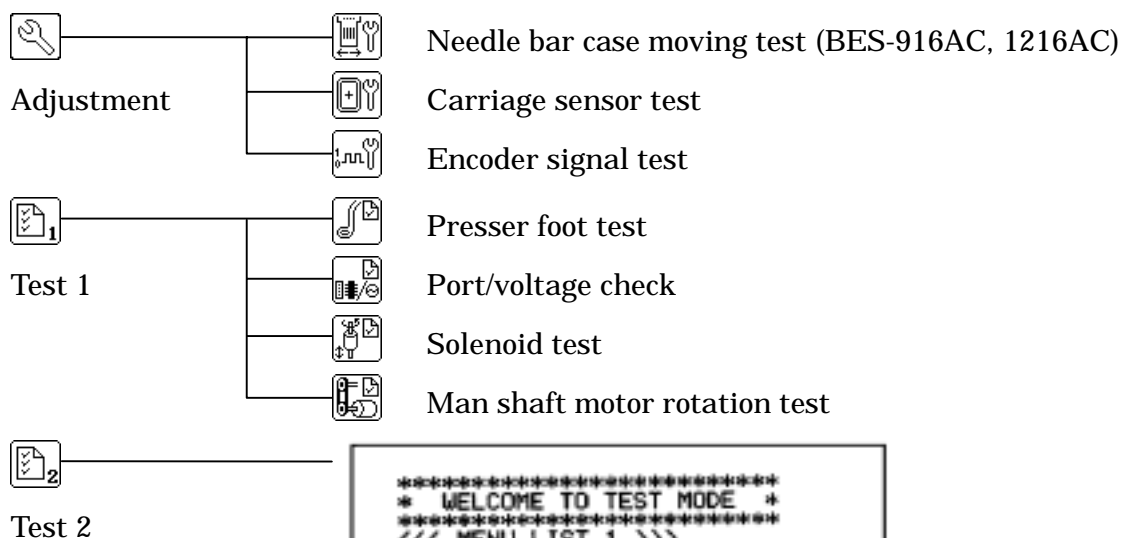





Select the menu by inputting the first figure of each menu with a numeric key.

Only six lines are displayed on the screen. However, the screen scrolls and the sections not displayed are shown if you press the ▲ or ▼ jog key.

It is switched to the highlighted “Result screen” if you select the item which displays the result.

Press the  key to return to the normal menu screen.

If you press the  key on the “Result screen”, the data on the result screen can be stored on the floppy disk. Moreover, pressing the  key will clear the displayed data on the result screen.

If “Insufficient memory” is displayed during the test, press the  key or  key on the “Result screen” and clear the displayed data on the result screen.

5-3. Function of the test mode

5-3-1. Needle bar moving test

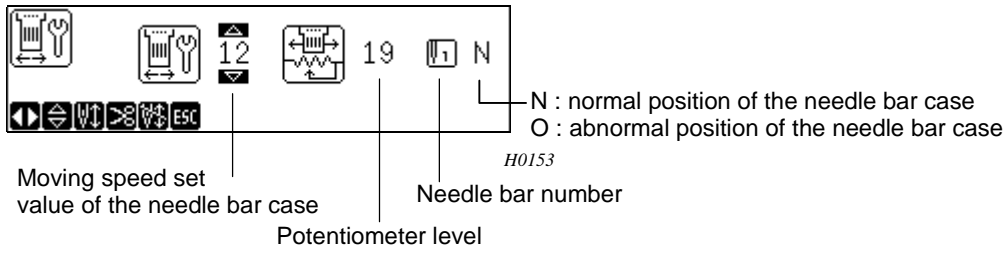

- If you press the left needle bar switch key, the number of the needle bar increases by one.

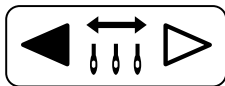

H0154

- If you press the right needle bar switch key, the number of the needle bar decreases by one.

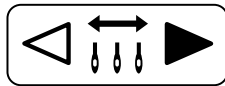

H0155

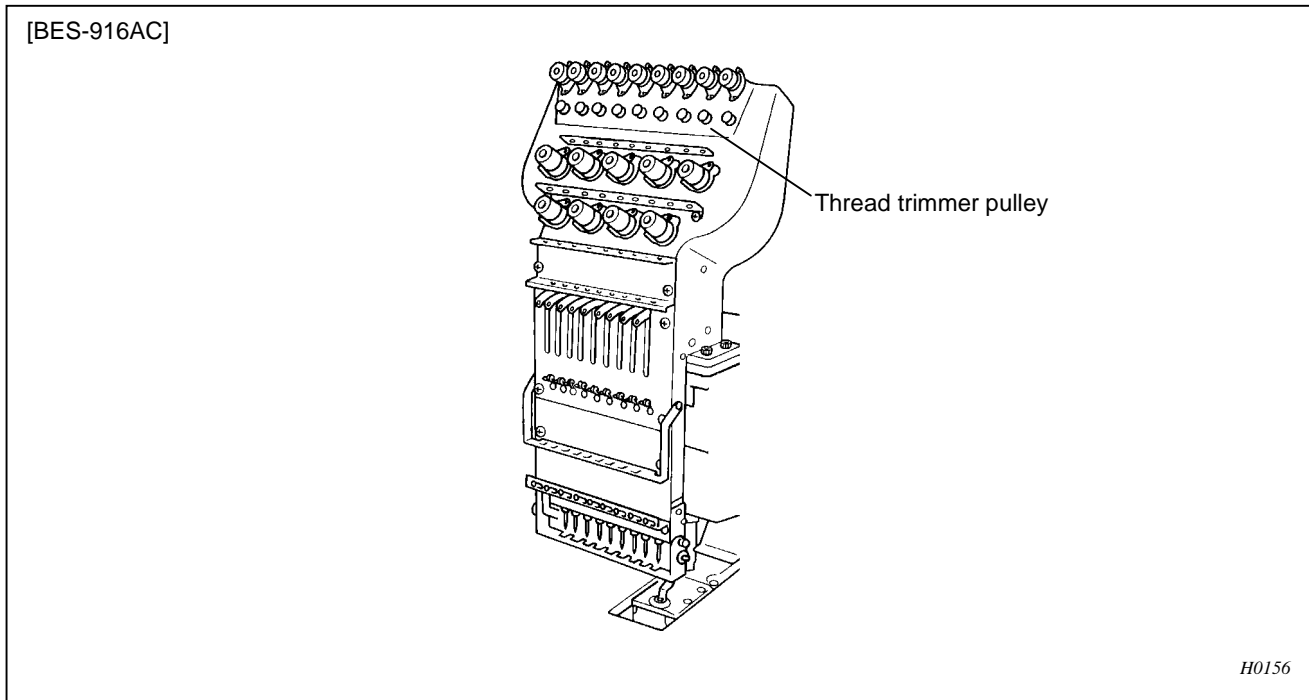

[BES-1216AC]

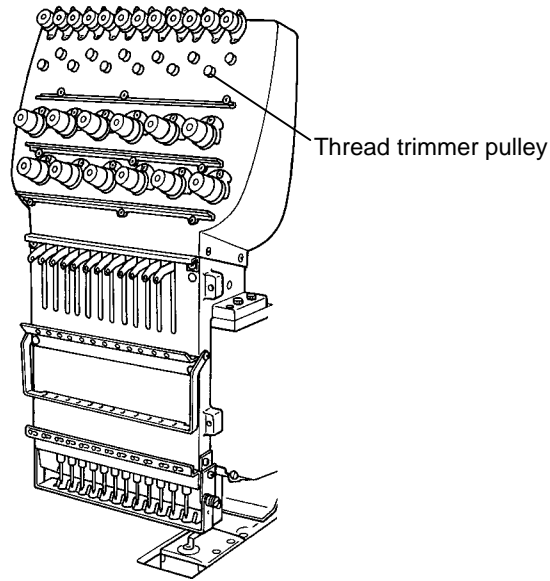



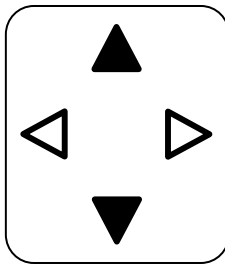

H0157

- When the thread trimmer pulley of the needle bar selected is turned, the icon of needle bar number blinks.
- When the \triangle or ∇ jog key is pressed, the needle bar's travel speed can be changed.



H0158

- Jog key(\triangle)----- increases the set value by one.
- Jog key(∇)----- decreases the set value by one.
- The set values can be set between 8 (fast) and 30 (slow). The standard set value is 12.
- When the  key is pressed, the contentious needle bar switching operation is repeated between one needle and nine needles (twelve needles for BES-1216AC).
- When the  key is pressed, the above operation stops.
- When the thread trimming key is pressed, the thread trimming operation is carried out starting from the first needle. When the operations for all needles are finished, operation returns to the state when the thread trimming key was pressed and the machine stops.
- When the  key is pressed during the operation, the operation is interrupted and the machine stops.
- When the  key is pressed, the display returns to the menu selection screen.

5-3-2. Carriage sensor test, stopper adjustment



H0159

Select the flat hoop or cap hoop icons with the jog keys (◀ and ▶).

When the  key is pressed, the hoop moves to the origin of the selected icon.

When the  key is pressed, the message, “The hoop moves” changes to the message, “Detecting the origin” and the machine starts the over-travel sensor test.



H0160

Select an icon with the jog keys (◀ and ▶) and press the  key. The message, “Moving frame” changes to the message, “Detecting home position” and the coordinate value of the stopper is displayed at the over-travel sensor and the Y direction.

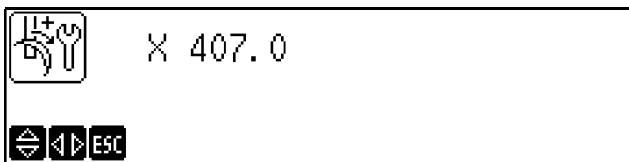

H0161

The hoop can be moved with the jog keys . The buzzer sounds when the screen shown at left is displayed if the installation position of the over-travel sensor and the sensor dog is properly adjusted.

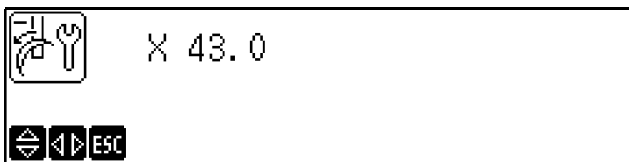

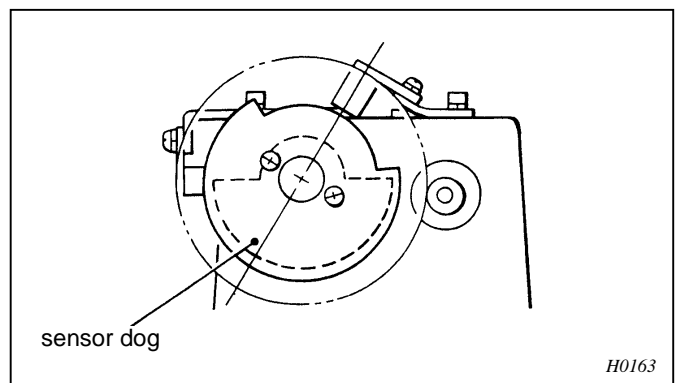

H0162

If the buzzer does not sound, adjust the over-travel sensor installation position and sensor dog so that the buzzer sounds between 406.5 to 407.5 and 42.5 to 43.5.



H0163

When the  key is pressed, the message, “Moving frame” changes to the message, “Detecting home position” and the machine returns to the over-travel sensor test.

When the  key is pressed again, the machine returns to the carriage sensor test.

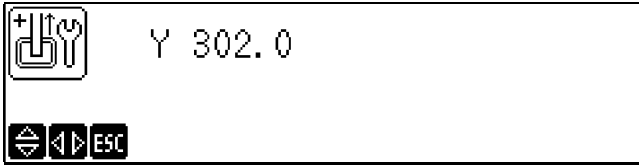

H0164

Adjust the right and left stopper in the back of the machine to make contact with the carriage at the point where Y302.0 is displayed.

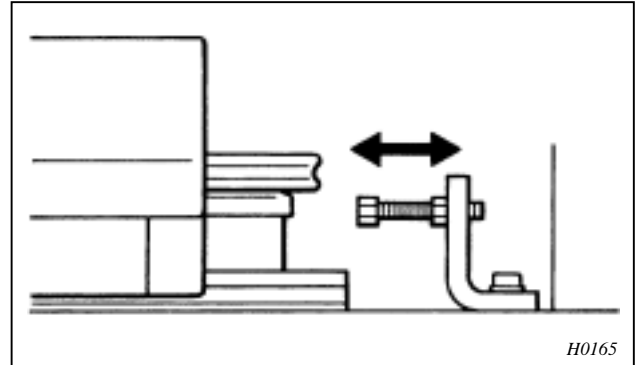

Press the key.

The presser shaft will be raised, the home position plate will be moved until the hole in it is almost aligned with the needle tip, and the presser shaft will be lowered.

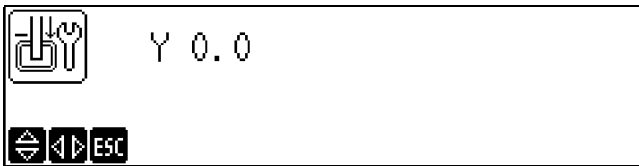

H0166

When Y0.0 is displayed, the machine was shipped by the state that it is in with the front mechanical stopper in the carriage about 11mm of openings.

This is a reference point for the X- and Y-carriages. Do not change this clearance.

5-3-3. Encoder signal test

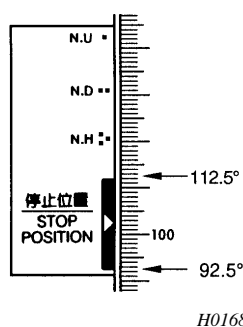
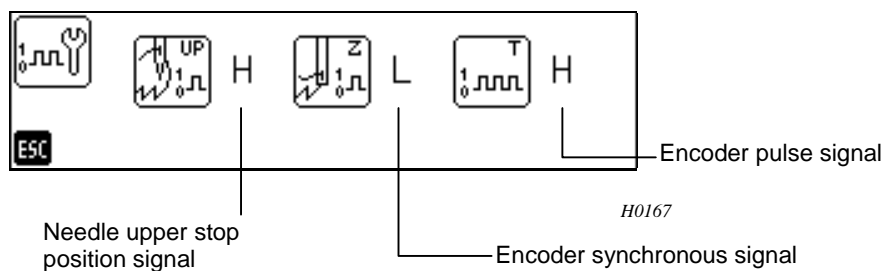

When the pulley is turned at the needle upper stop position (at 92.5 to 112.5 degrees of the scale on the pulley), the buzzer sounds and “H” is displayed.

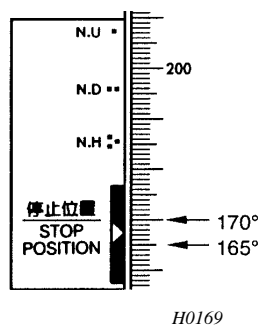

When the pulley is turned at the synchronous signal position (at 165 to 170 degrees of the scale on the pulley), “H” is displayed. When the pulley is turned, the pulse signal displays “H” or “L” alternatively.

When the key is pressed, the display returns to the menu selection screen.

(NOTE) The adjustment of the encoder is described in “5-4. Adjusting the rotary encoder and sensor PCB” on page 71.

5-3-4. Presser foot test



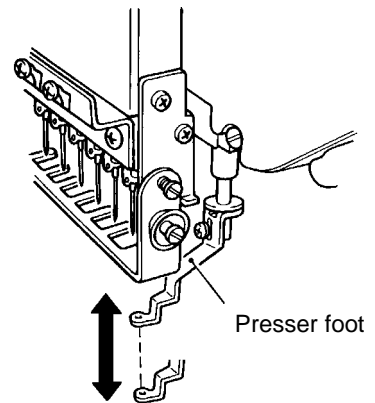

H0170



H0171

When the jog switch (\triangle) is pressed, the presser foot rises,  is displayed, and the buzzer sounds.

When the jog switch (∇) is pressed, the presser foot lowers and  is displayed.

When the  key is pressed, the presser foot rises and the display returns to the menu selection screen.

5-3-5. Port/voltage check

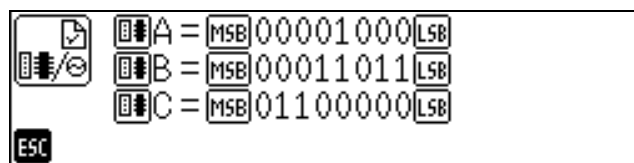

Displays the current status of ports A, B, and C.

H0172

Details of what are displayed are as follows:

	MSB	BIT7	BIT6	BIT5	BIT4	BIT3	BIT2	BIT1	BIT0	LSB
Port A		full-time 0	full-time 0	full-time 0	Thread trimmer detect pulley rotate =0,1 change	full-time 1	Cap 0V sensor Shielded= 1 opened=0	X origin sensor Shielded= 1 opened=0	Y origin sensor Shielded= 1 opened=0	

	MSB	BIT7	BIT6	BIT5	BIT4	BIT3	BIT2	BIT1	BIT0	LSB
Port B		full-time 1	full-time 1	full-time 1	full-time 1	full-time 1	full-time 1	full-time 1	full-time 1 or 0.1change (NOTE)	

(NOTE) When two cooling fans are installed in the control box, the number is changed by 0.1

(For BES-116AC, 916AC, 1216AC)

	MSB	BIT7	BIT6	BIT5	BIT4	BIT3	BIT2	BIT1	BIT0	LSB
Port C		full-time 1	full-time 1	full-time 0	Full-time 0	full-time 0	full-time 0	full-time 0	full-time 0	

(For BES-116AC with air clamper)

	MSB	BIT7	BIT6	BIT5	BIT4	BIT3	BIT2	BIT1	BIT0	LSB
Port C		full-time 0	foot SW OFF=1 ON=0	full-time 0	full-time 0	full-time 0	full-time 0	full-time 0	full-time 0	

(MEMO) As for each sensor signal, "1" indicates that the sensor is shielded and "0" indicates that the sensor receives light.

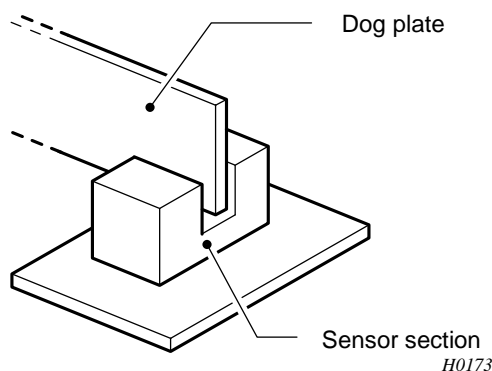

"Shielded" refer to the state when the sensor dog is in the sensor section.

"Receiving light" refers to the state when the sensor dog is removed from the sensor section.

H0173

5-3-6. Solenoid test

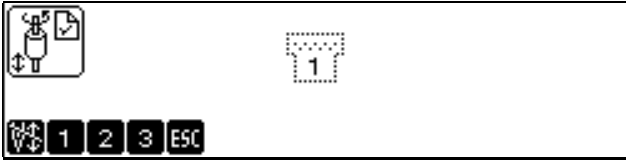

H0174

The presser foot lowers and the screen shown to the left is displayed.

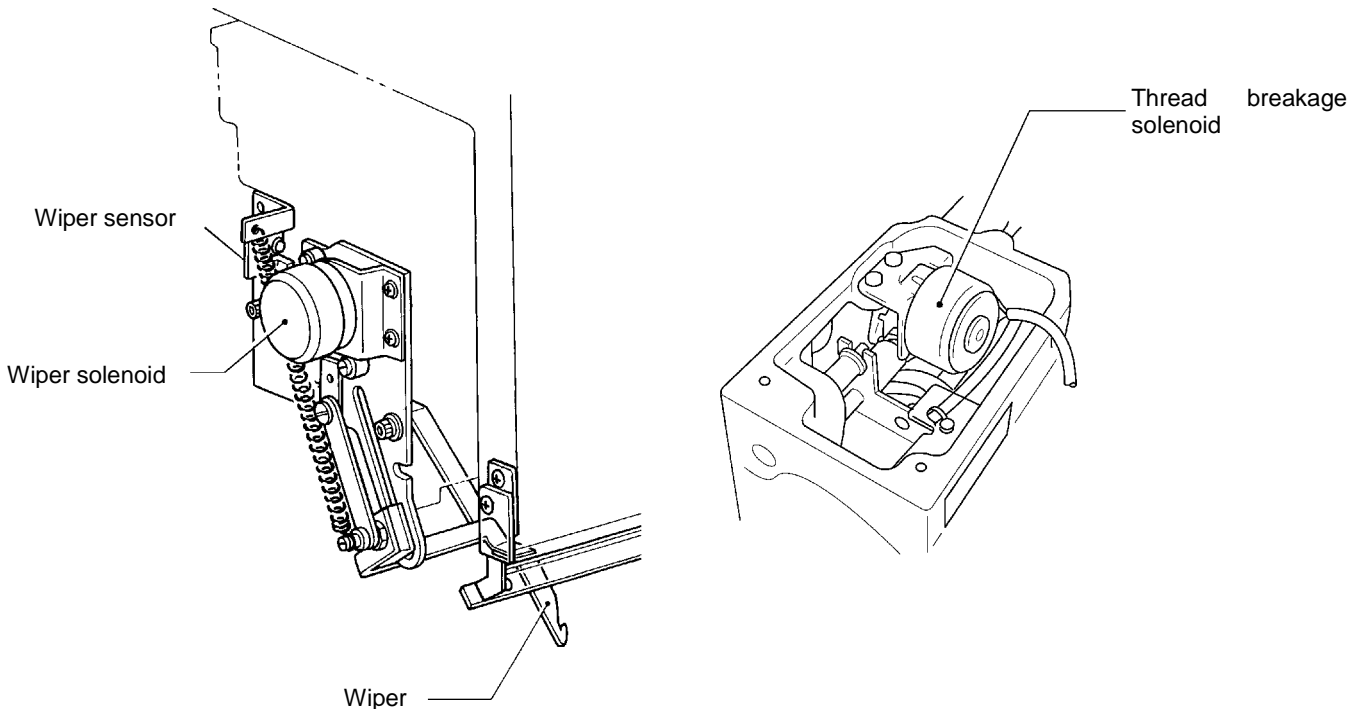

H0175

When the **1** key is pressed, the thread breakage solenoid and the wiper solenoid are moved once. **1** is displayed while the screen is highlighted, when the wiper is out.

The wiper sensor receives light (the sensor dog is removed) at this time.

When the **2** key is pressed, the jump solenoid and the picker solenoid repeats drive. When the **STOP** key is pressed, it stops.

When the **3** key is pressed, driving of the jump solenoid is maintained. When the **STOP** key is pressed, it is cancelled.

When the **ESC** key is pressed, the presser foot rises and the display returns to the menu selection screen.

5-3-7. Main shaft motor rotation test

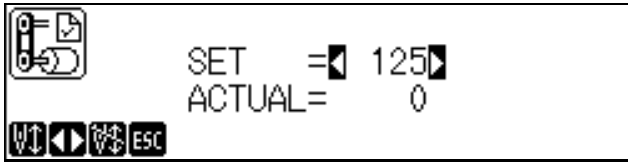

H0176

- [Left Arrow] [Up Arrow] [Right Arrow] steps up the set value of the speed.
- [Left Arrow] [Down Arrow] [Right Arrow] steps down the set value of the speed.

- When [START] is pressed, the main shaft starts rotating.
- When [STOP] is pressed, the main shaft stops rotating.

The actual rotation number is indicated after "ACTUAL=".

- When the [ESC] key is pressed, the display returns to the menu selection screen.

5-3-8. Detailed version of CPU in the machine

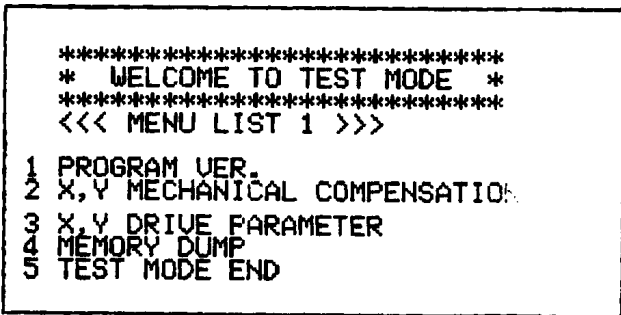

H0177

Select "1. PROGRAM VER." in <<MENU LIST 1>>.

(NOTE) Refer to "5-2. Selecting the test mode menu" to enter <<MENU LIST 1>>.

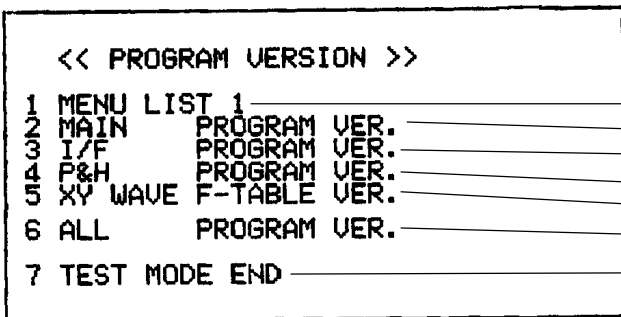

H0178

- Return to <<MENU LIST 1>>.
- Main CPU program
- Slave I/F CPU program
- Panel and head CPU program
- XY feed wave from table
- All CPU programs in the machine
- Exit the test mode.

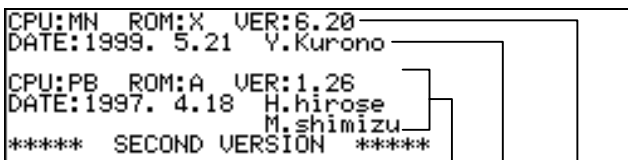

H0179

- Information of the base program of the selected CPU
- Production date Producer
- CPU type and simplified version
- Detailed version

When 2 to 7 is selected in <<PROGRAM VERSION>>, the screen shown to the left (example) is displayed.

When the [*] key is pressed, it returns to <<PROGRAM VERSION>>.

5-4. Adjusting the rotary encoder and sensor PCB

- The rotary encoder and sensor PCB is used to detect the needle stop position and synchronize hoop motion.
- When the machine stops after thread trimming or is stopped for an emergency during sewing, the needle bar is in the jump condition (stopped in the raised position), and the thread take-up stops at the position that is the same as eight of other (for BES-916AC).

5-4-1. Adjusting the machine stop position signal

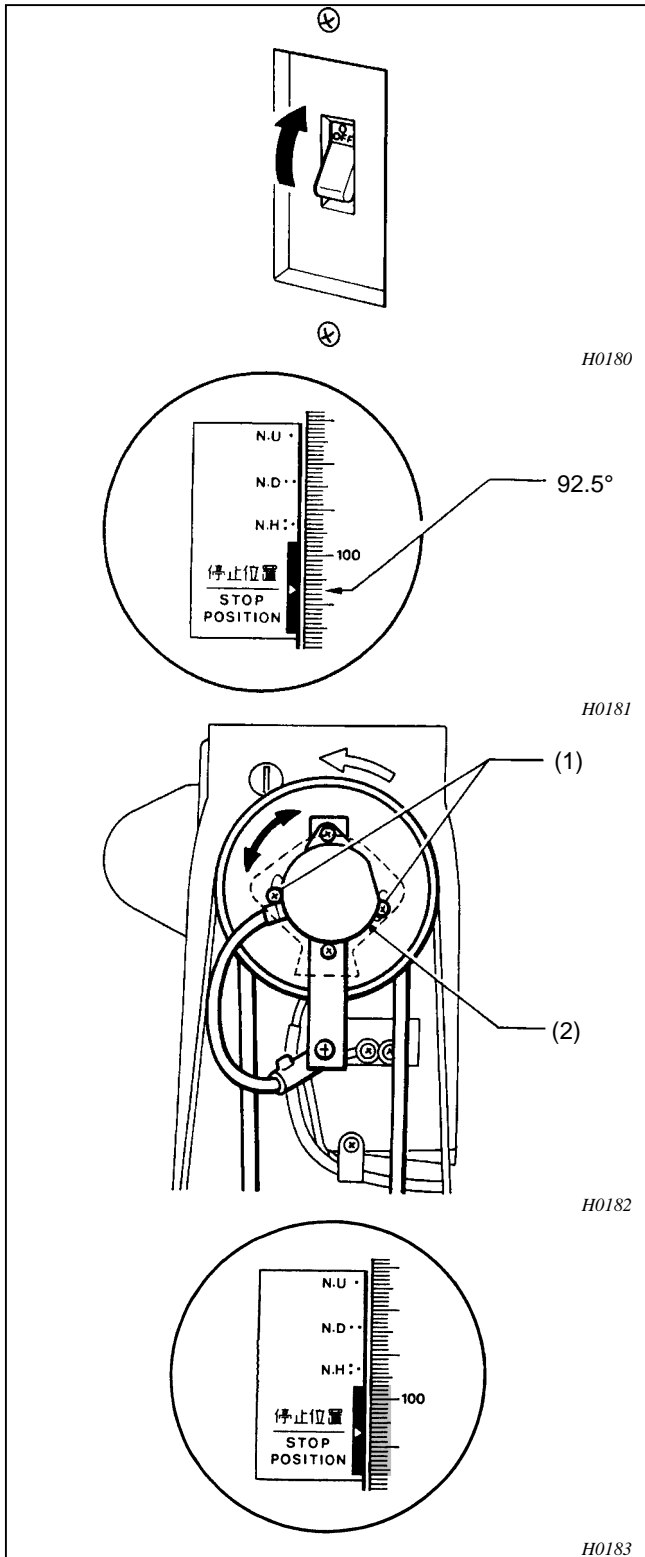

1. Turn on the power, and the machine starts the encoder signal test in the test mode.
Refer tot page 61, "Test mode".

2. Turn pulley B (1) in the normal direction. Loosen the screws (2) to adjust the dog (3) so that the buzzer starts sounding and  becomes "H" when the scale on the pulley indicates 92.5 degrees.

(MEMO) If the stop position signal is correctly adjusted,  becomes "H" and the buzzer sounds when the scale on the pulley indicates between 92.5 an 112.5 degrees.

5-4-2. Adjusting the synchronizing signal

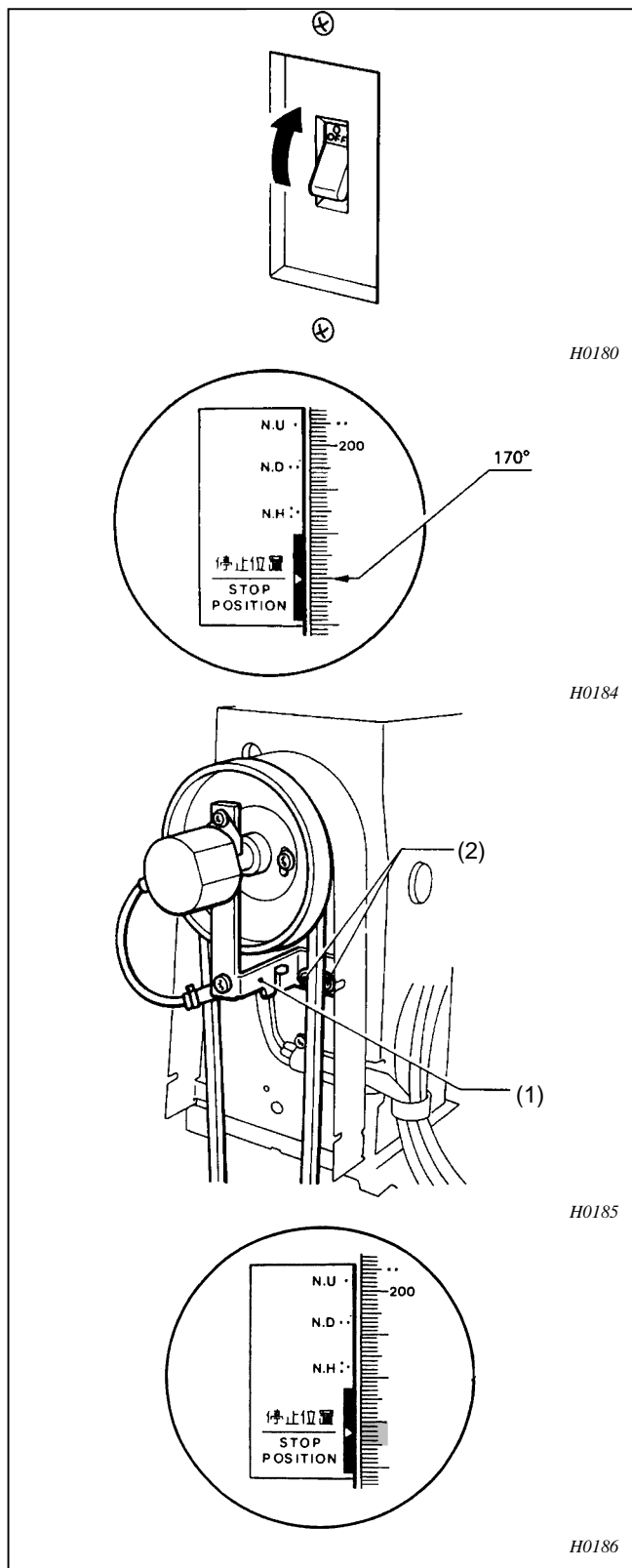

1. Turn on the power, and the machine starts the encoder signal test in the test mode. Refer tot page 61, "Test mode".

2. Loosen two screws (2) at the arm side of the encoder adjustment plate (1) to adjust the angle so that the buzzer stops and becomes "L" when the scale on the pulley indicates 170 degrees.

(MEMO) If the synchronous signal is correctly adjusted, becomes "H" and the buzzer sounds when the scale on the pulley indicates between 165 and 170 degrees.

5-5. Adjusting home position using home position plate





(NOTE) Use the XY-axis home position plate assembly (S36461-001 optional).

(NOTE) Before making this adjustment, turn the power switch off and prepare the attachment of the plate and the removal of the cover.

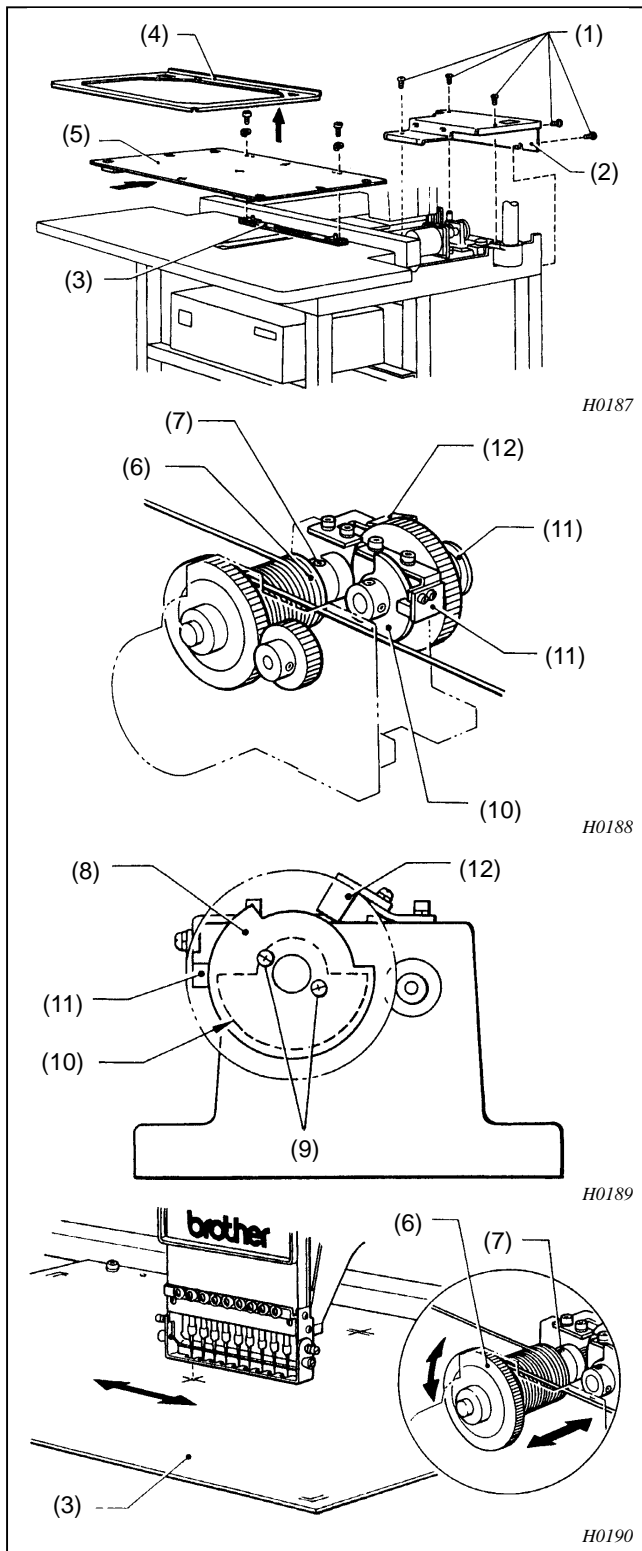
(NOTE) Be sure to remove the presser foot.





<X-direction>

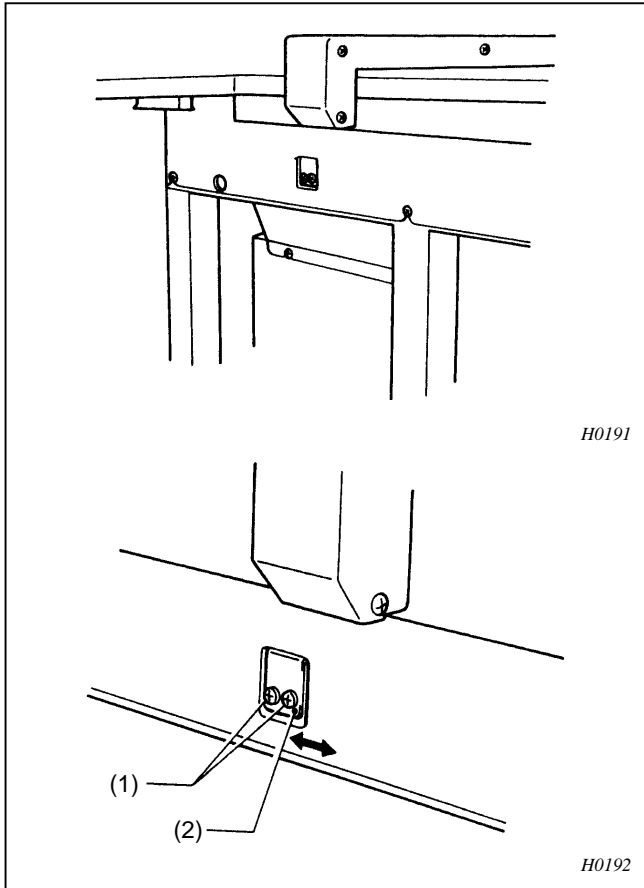

1. Remove the eight screws (1) and table R (2).
2. Remove the holder base (4) from the carriage (3), and then attach the XY-axis home position plate assembly (5).
3. Loosen set screw (7) of wire drum X (6) so that wire drum X (6) can turn idly.
4. Temporarily tighten the screw (9) so that the X-limit dog cap (8) is centered in its hole.
5. Attach the X-limit dog cap (8) so that its notch faces toward the sensor (12) when the X-axis home position dog (10) interrupts the sensor (11) light.
6. While pushing  key, turn on the power.
7. The machine detects the X-home position and the XY-axis home position plate (3) stops.
8. "Memory clear" is displayed. Push  key. "Deleting" is displayed, and the initial screen is displayed.
9. Turn XY-home position plate assembly (3) manually and adjust the needle tip position so that it is in the center of the cross of the XY-axis home position plate (3). Then, tighten screw (7) firmly so that there is no end play of the shaft.
10. While pushing  key and  key, the machine detects home position again.
11. Repeat the procedure 9 and 10 to adjust.

<Y-direction>



1. While pushing  key, turn on the power.
2. The machine detects the X-home position and the XY-axis home position plate 3 stops.
3. "Memory clear" is displayed. Push  key. "Deleting" is displayed, and the initial screen is displayed.
4. Loosen the screw (1) and adjust the sensor bracket (2) to move it for Y axis direction so that the needle tip position is aligned in the center of the cross of the X-Y axis home position plate.
5. While pushing  key and  key, the machine detects home position again.
6. Repeat the procedure 4 and 5 to adjust.
(NOTE) Move the sensor bracket (2) toward the center if the needle is not in the center of the cross.

5-6. Adjusting the overtravel sensor and flat hoop stopper using the home position plate

The sensor and stoppers are used for checking sewing area during sewing and for mechanism protection.

Cap frame overtravel sensor and flat hoop stopper positions.

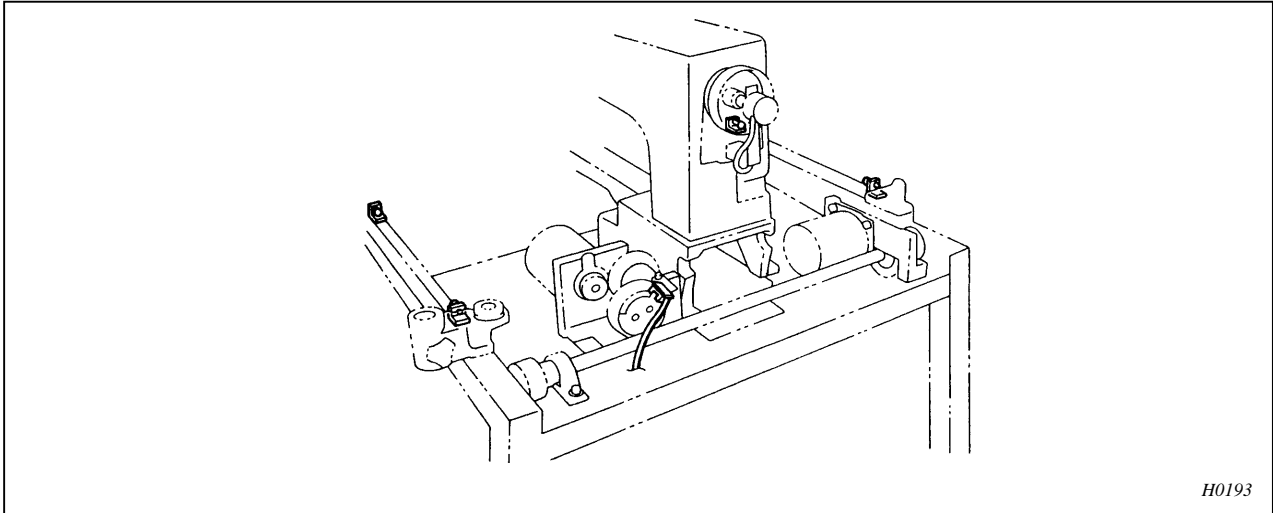

Adjusting cap frame overtravel sensor (X direction)

(MEMO) Use "Carriage sensor test" in the test mode.

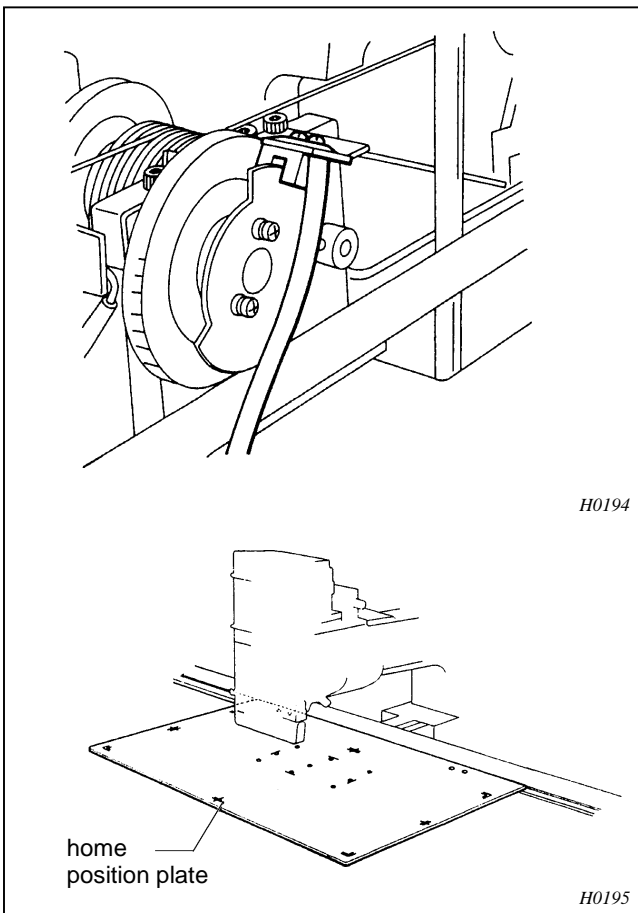

(NOTE) Be sure to remove the presser foot.

Attach the home position plate (S36461-001) to the carriage.

(NOTE) The home position plate is an optional part. Consult with your dealer.

6. Upgrading version of machine program

This chapter explains how to upgrade the version of programs using the upgrade file which is supplied on the floppy disk, or sent by e-mail.

6-1. Downloading the file

1. Create a temporary directory (i.e., C:\TEMP) to save a self-extracting file on the hard disk.
2. Click the language of the file to download and start downloading the file.
3. Designate the directory created in step 1 above to save the downloaded file.
4. Double-click the downloaded file to extract it.
The downloaded file can also be extracted by clicking the [Start] button and selecting [Run the file]. Input the directory created in step 1 above and the name of the downloaded file and click the [OK] button. (For example, "C:\TEMP\916V***" for nine needles and "C:\TEMP\1216V***" for twelve needles.)

6-2. Creating the installation disk

When the file is extracted according to "Downloading the file" above, the following three files are created.

		File name (BES-1216AC)	File name (BES-916AC)	File name (BES-116AC)
1	Setup disk	SETUP1216-***.bup	SETUP916-***.bup	SETUP116-***.bup
2	DISK1	1216AC-***M.bup	916AC-***M.bup	116AC-***M.bup
3	DISK2	SA1216-***P.bup	SA916-***P.bup	SA116-***P.bup

(***varies according to the version of the software downloaded.)



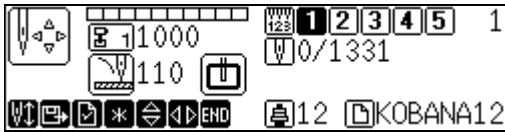

1. Prepare three empty 1.4MB floppy disks.
2. Copy all files separately to each disks.
3. Write down each file names on to disk labels.

6-3. Using the installation disk (upgrading the program)

1. Press the  key twice during standby.





H0196

2. Press the jog keys ( ) to select  (on the right end), and press the  key.
Do not insert the installation disk yet.



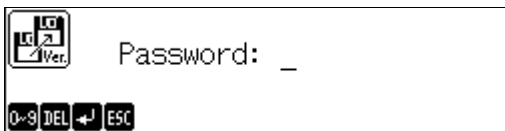

H0197

3. Input "961" as the password and press the  key.
Delete the incorrect password with the  key and input the correct one.



H0198

4. Select  and press the  key.



H0199

* This screen may not be displayed.

5. Press the  key to continue the upgrading procedure.

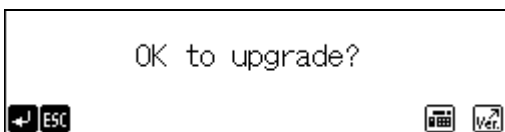

H0200

6. Insert the floppy disk with the label "SETUP***-***.BUP" when the following screen is displayed and press the  key.



H0201

Go to step 8 if the following screen is displayed.



H0202

7. Installation from "SETUP***-***.BUP" starts.

8. The following screen is displayed when installation is completed. Insert the floppy disk with "***AC-***M.BUP" ("1216AC-***M.BUP" for twelve needles) written on its label and press the  key.



H0203

9. Installation from "***AC-***M.BUP" ("1216AC-***M.BUP" for twelve needles) starts.

10. The following screen is displayed when installation is completed. Insert the floppy disk with "SA***-***P.BUP" written on its label and press the  key.

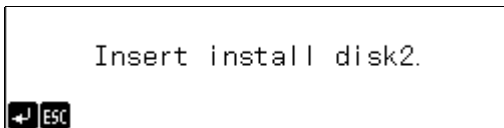

H0204

11. Installation from "SA***-***P.BUP" starts.

12. The following screen is displayed when installation is completed. Remove the floppy disk and turn off the power of the sewing machine. This completes the upgrading procedure.

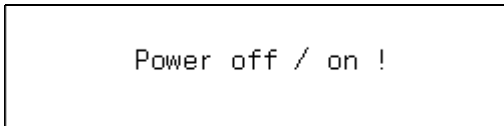

H0205

7. Lubrication

CAUTION



Turn off the power switch at the following times, otherwise the machine may operate if the start switch is pressed by mistake, which could result in injury.



Be sure to wear protective goggles and gloves when handling the lubricating oil and grease, so that they do not get into your eyes or onto your skin, otherwise inflammation can result.

Furthermore, do not drink the oil or eat the grease under any circumstances, as they can cause vomiting and diarrhea.

Keep the oil out of the reach of children.

7-1. Machine head

Lubrication is necessary for keeping the machine in good condition.

BES-116AC, 916AC, 1216AC has the lubrication system using wicks and an oil tank. Every day before using the machine, refill the oil tank with new oil if the oil level falls viewing through the oil window.

(NOTE) Be sure to use the Brother-specified sewing machine oil for lubrication.

(NOTE) Supplying too much oil may cause it to drip onto the material.

Lubricate each point indicated with the arrow when the machine is used for the first time after unpacking or if left machine unused for along period of time.

(MEMO) Confirming the remaining of oil in the tank, and lubricate when the tank is empty.

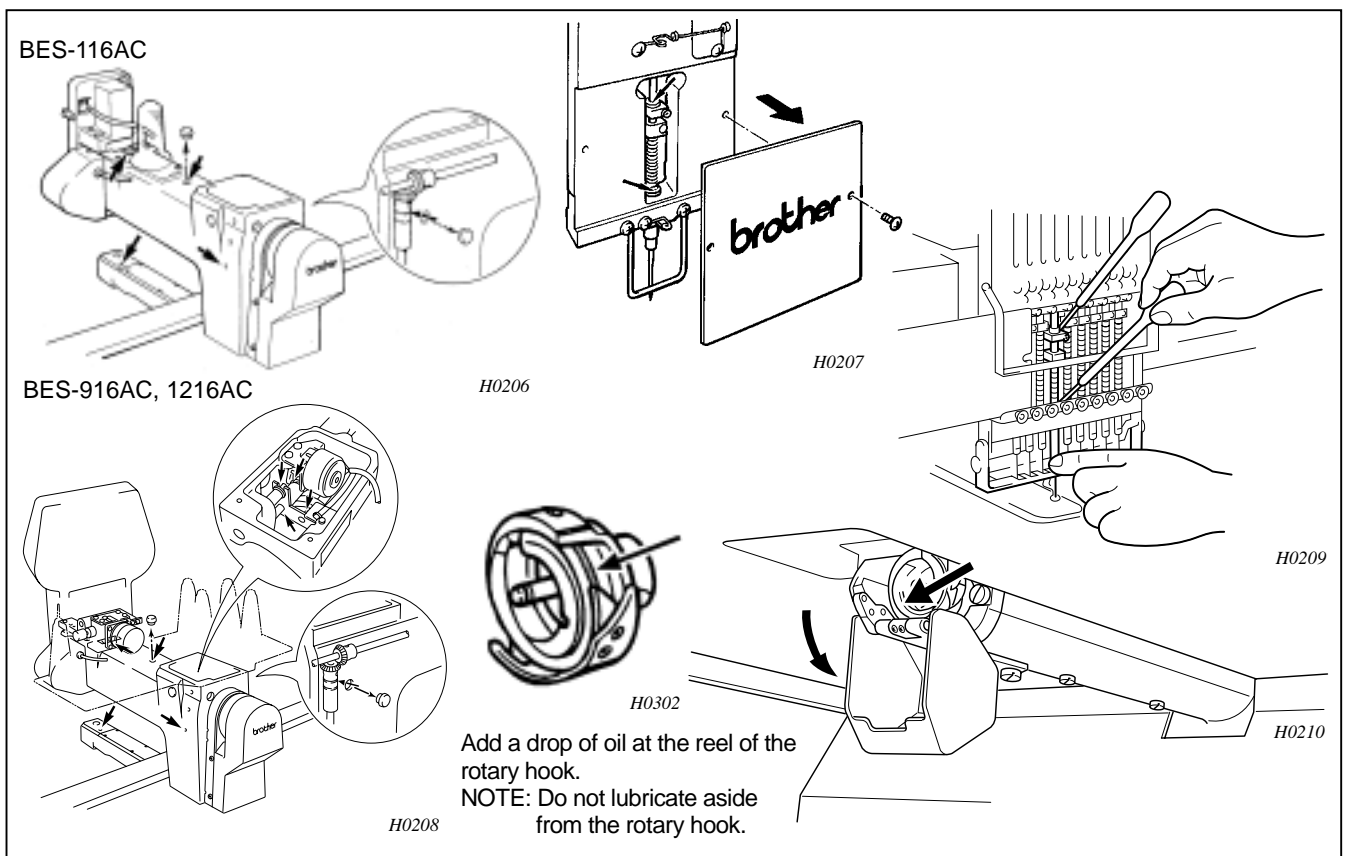

Refill with new oil from the holes indicated with arrows if necessary.

(NOTE) Replenish oil in the machine front oil tank once a week.

(NOTE) Oil may run out in the tank after one or two nouns of operation, but a part that can keep extra oil is incorporated into the machine front oil tank, so that even with no oil tank, oil can be supplied from this part little by little.

BES-116AC

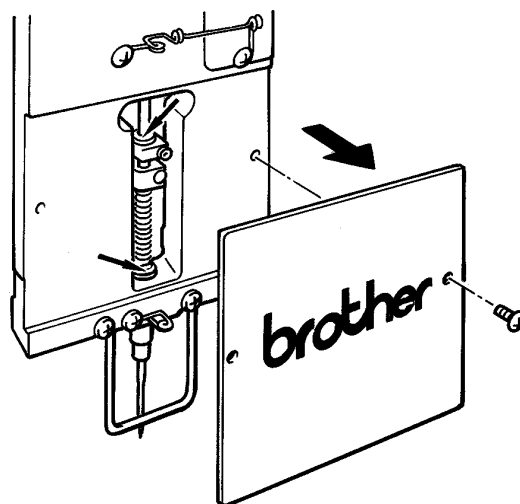
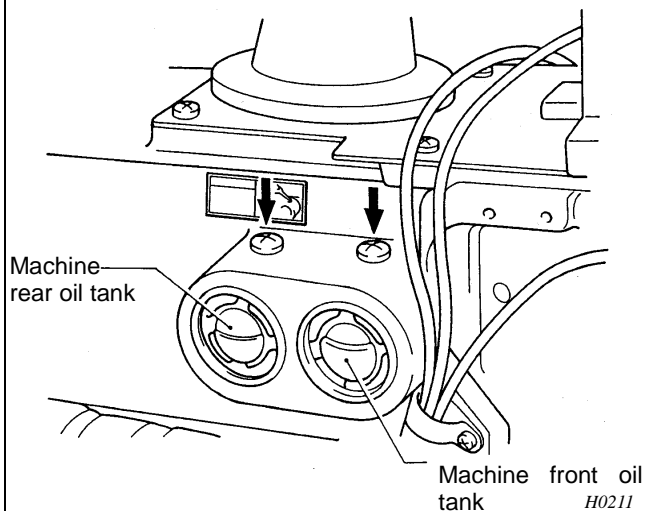

BES-916AC, 1216AC

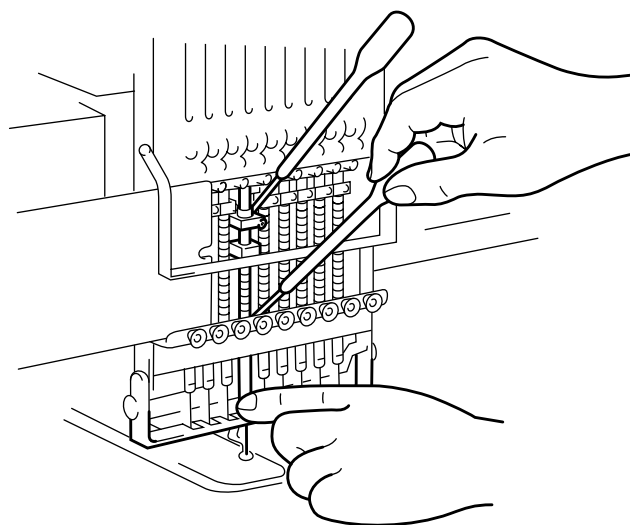
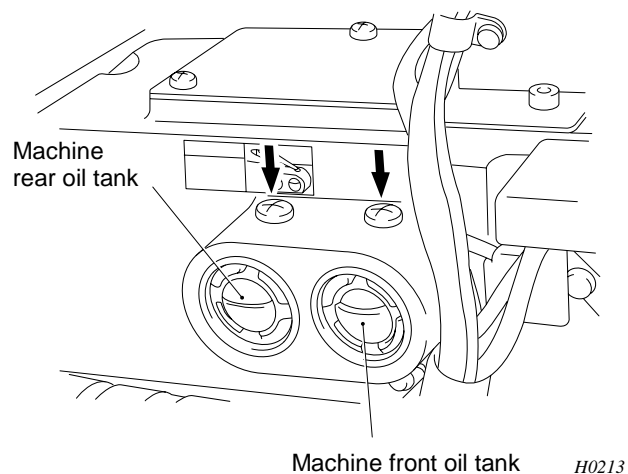

7-2. Feed guide mechanism (BES-116AC, 916AC, 1216AC)

Linear guide rail: X-axis

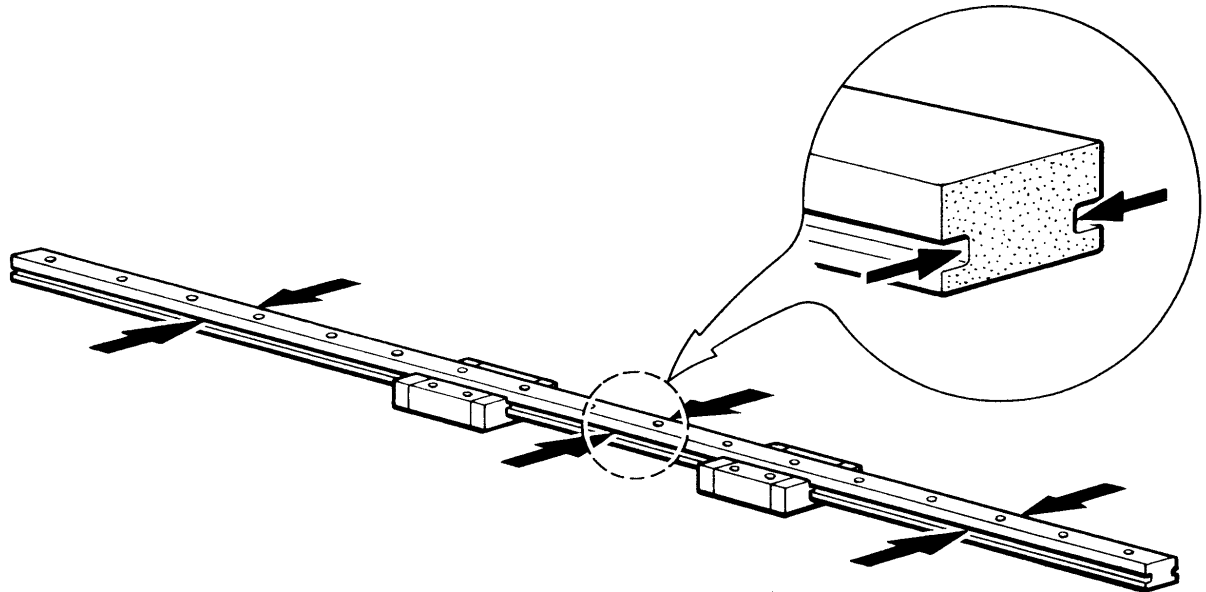

H0215

Linear guide rail: Y-axis

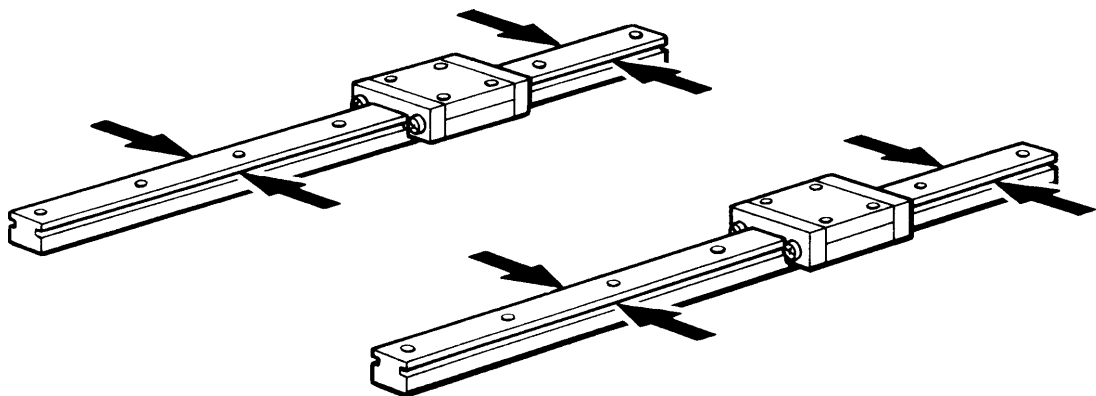

H0216

(NOTE) For lubrication, use Brother-specified grease tank 30.

(NOTE) Be sure to lubricate every 6 months.

(NOTE) After applying grease to the X-Y guide rail, move the X carriage right and left 2-3 times.

(NOTE) Before applying grease, remove covers to make the work easier.

7-3. Cleaning

Keep the machine clean and unclogged to prevent machine trouble.

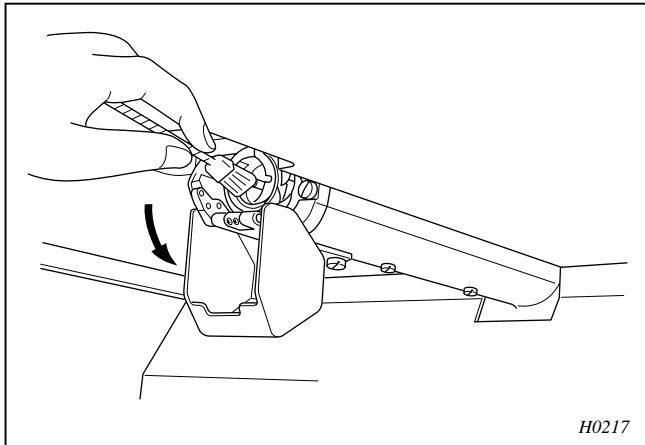

Keep the machine clean:

Remove dirt with a soft, dry cloth. If necessary, clean with a cloth soaked in detergent, then wipe off the detergent with a cloth dampened with (hot) water.

Caution:

Do not clean with benzene, thinner, or other volatile solvents.

Before working the machine, move the needle bar case all the way to the right and left, and remove oil and dirt around the needle bar guide rail and the shaft of the presser foot from the back of the needle bar case using a cloth.

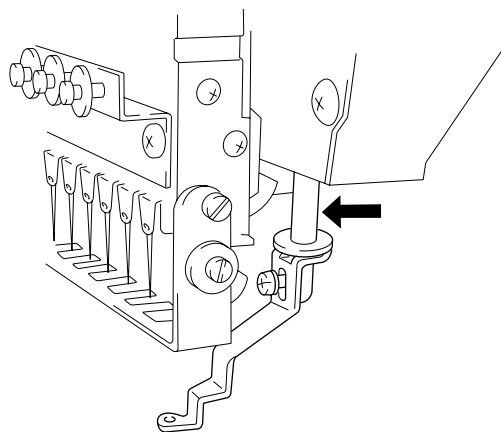
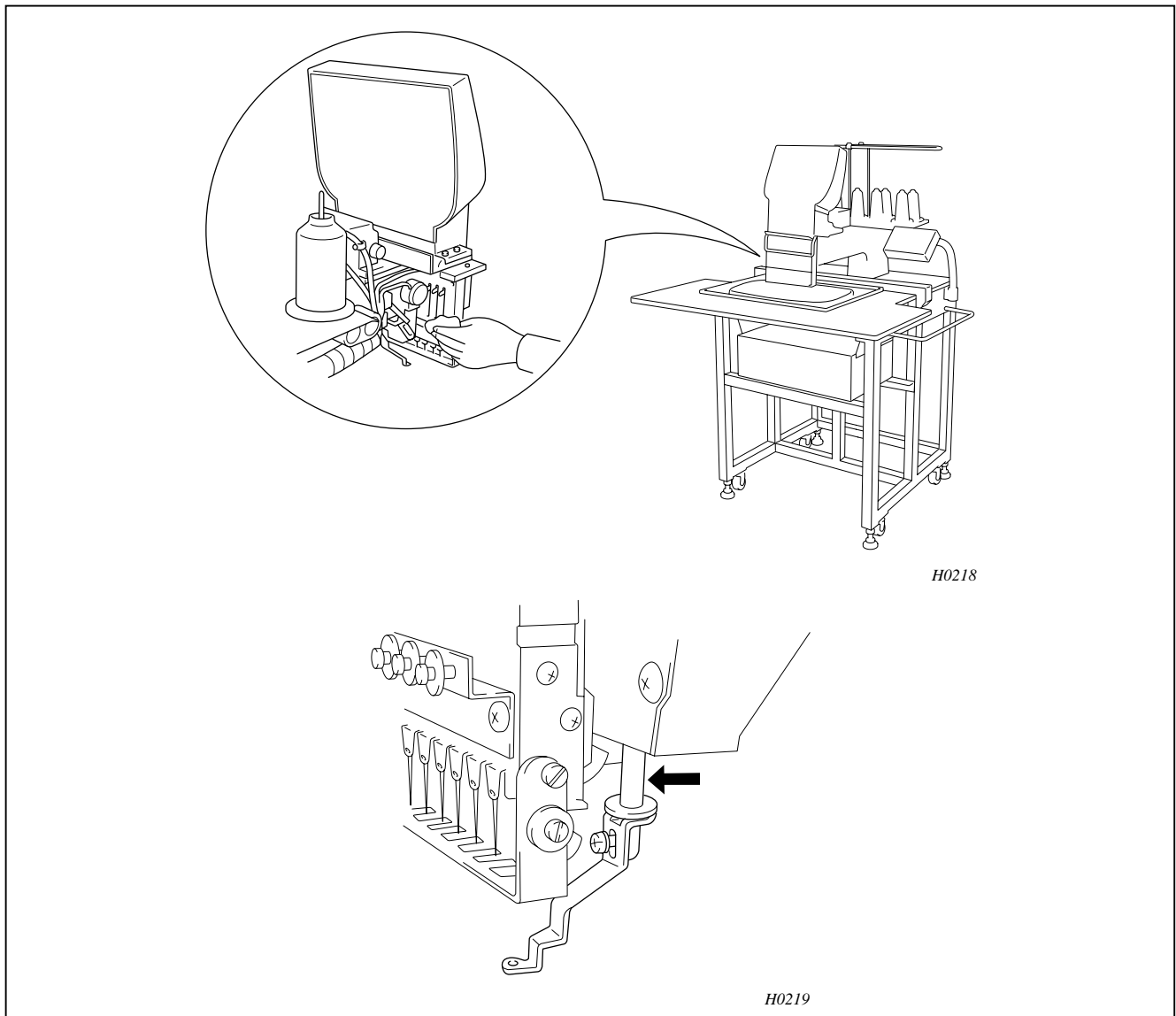

8. Electric components

DANGER



Wait at least 5 minutes after turning off the power switch and disconnecting the power cord from the wall outlet before opening the faceplate of the control box. Touching areas where high voltages are present can result in severe injury.

CAUTION



Contact your Brother dealer or a qualified electrician for any electrical work that may need to be done.



Be sure to connect the ground. If the ground connection is not secure, you run the risk of receiving a serious electric shock.

8-1. Circuit board locations

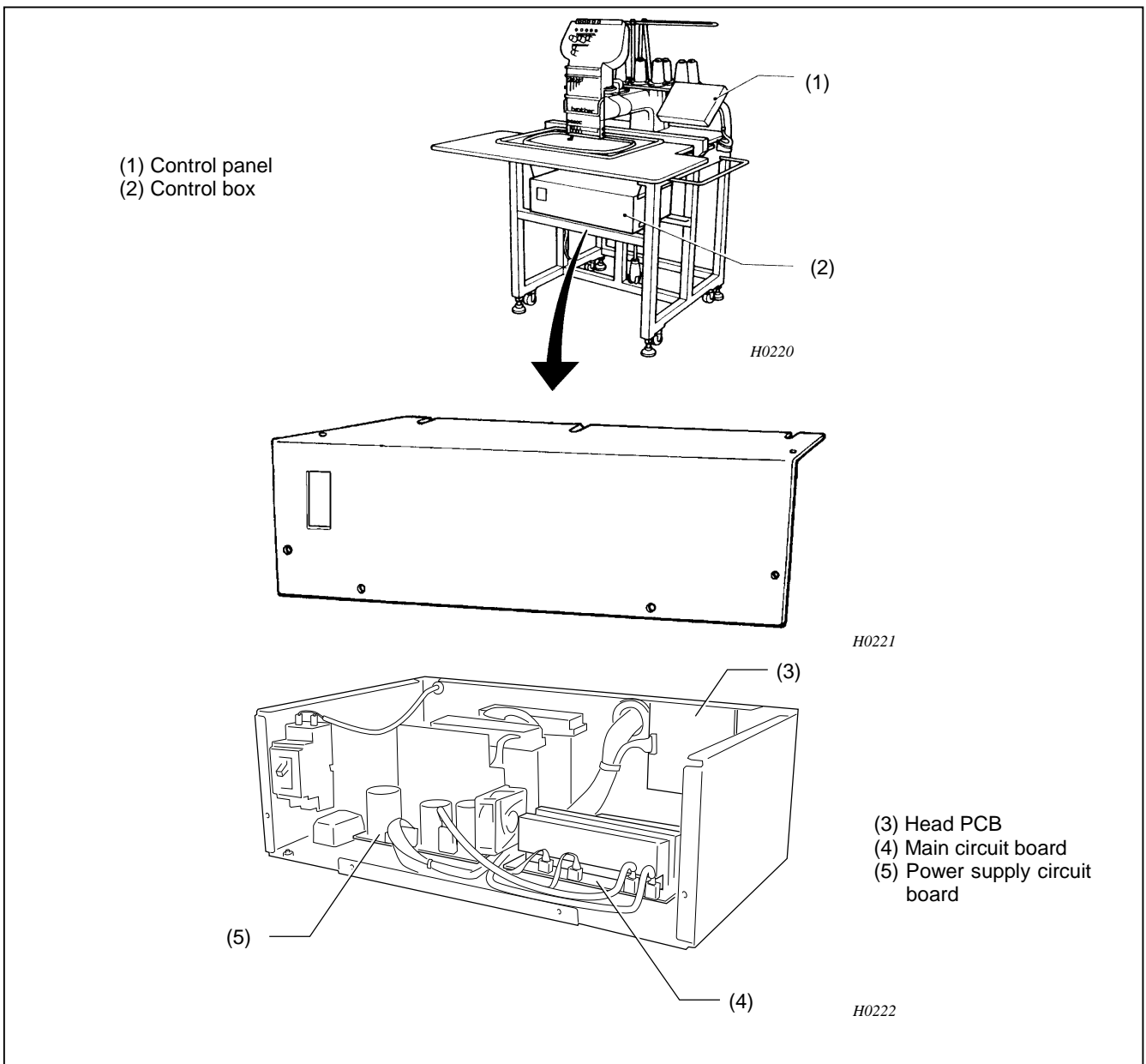

8-2. Replacing circuit boards

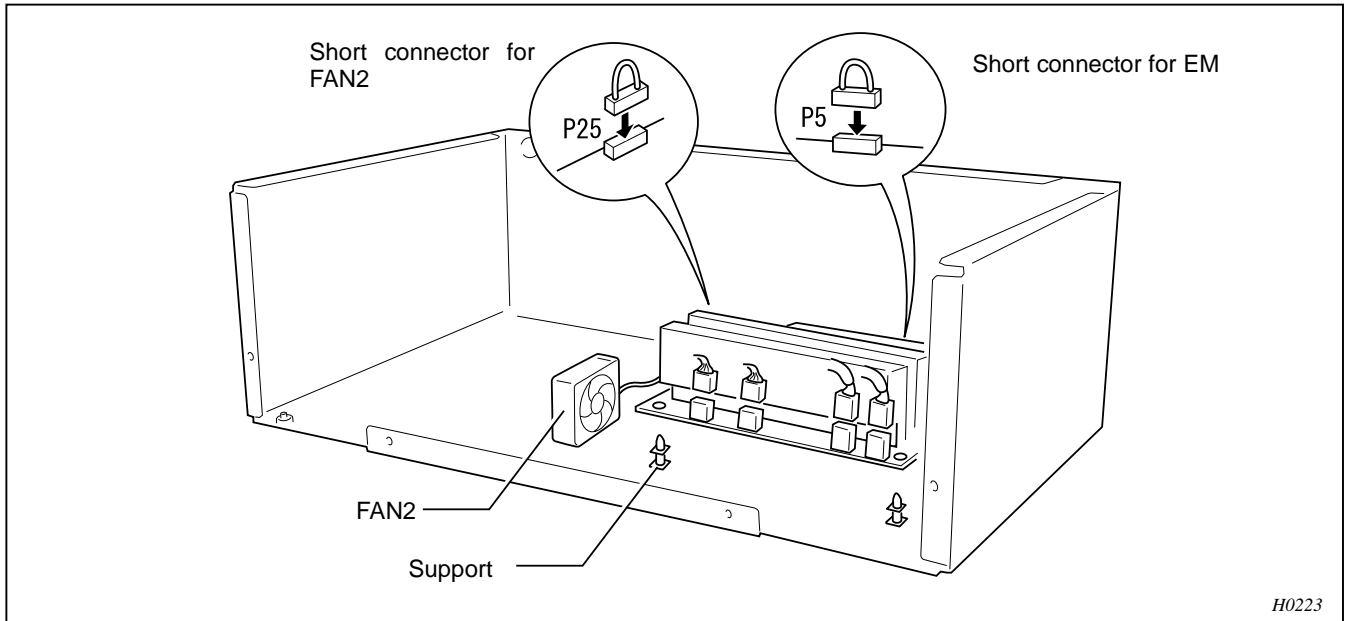

8-2-1. Main circuit board

(NOTE) Be sure to turn off the power and open the cover before replacement.

1. Disconnect all connectors.
2. Press the six circuit board support clamps inward and remove the main circuit board from the supports.
3. Replace the main circuit board.
4. Place new main circuit board on the supports.
Secure the circuit board by pushing down near each of the support clamps until it snaps into position.
5. Connect the connectors while supporting the circuit board from the back side.
Be sure not to treat the circuit board forcefully.

(NOTE) When replacing connectors, treat them carefully. Do not pull on the wires when detaching the connectors.

(NOTE) The connectors must be connected whenever the circuit board is replaced

(NOTE) Connectors of P13, P11, P10, P8, P4, P3 and P1 are not used and no cable is connected to them.

(NOTE) A cable isn't connected to the connector of P5, which is not used when an emergency stop switch is not attached. The short connectors are connected as substitute for the cable.

(NOTE) The short connector is connected to P25 when the cooling fan 2 is attached.

(NOTE) A cable isn't connected to the connector P23, which is not used when an air clumper (BES-116AC is optional) is not attached.

(NOTE) The Main Motor P-ROM (Refer to P.92), short connector of P5 and short connector of P25 are not attached to a new main circuit board. When replacing the main circuit board with a new one, be sure to remove them from the one replaced.

(NOTE) Treat the circuit boards carefully. CMOS-IC in the circuit boards is easily damaged by static electricity. Also, do not touch IC pins.

(NOTE) Do not bend circuit boards. The circuit pattern or IC may be broken by external force due to the large size of the circuit board.

(NOTE) The control program must be upgraded whenever the main circuit board is replaced.

8-2-2. Machine motor circuit board

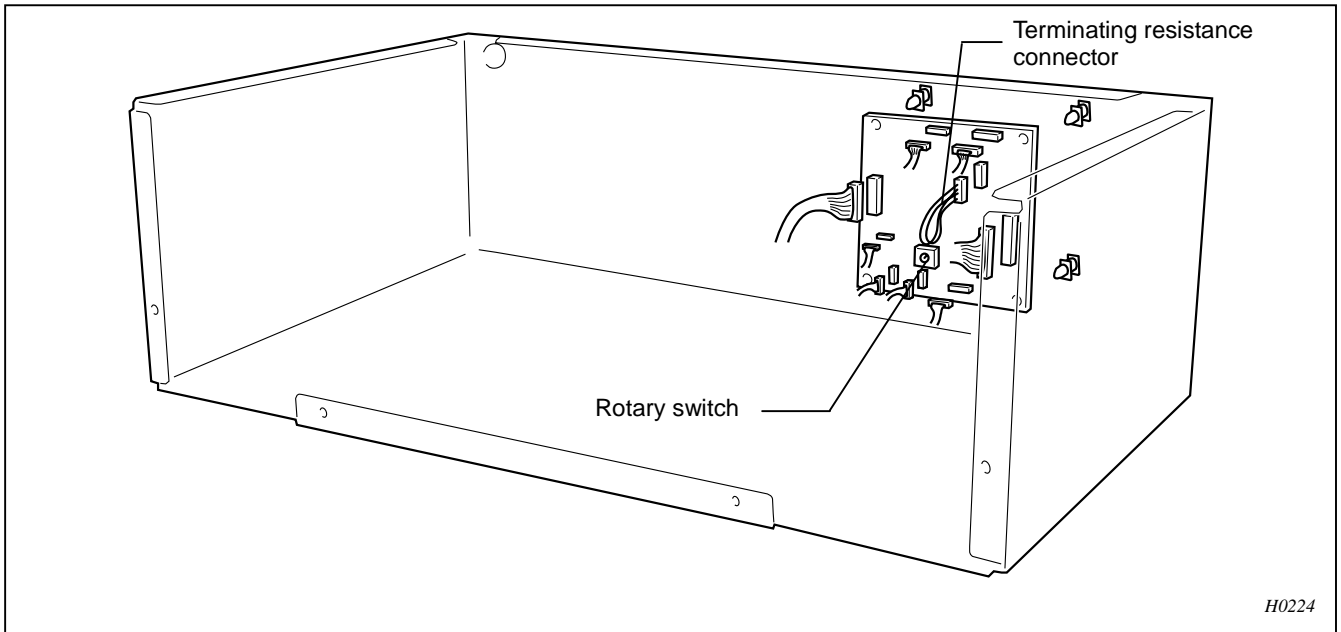

1. Disconnect the eight connectors. Disconnect the terminating resistance connector.
 2. Push the four circuit board supports towards the inside and remove the machine motor circuit board.
 3. Replace the machine motor circuit board.
 4. Place new machine motor circuit board on the supports.
Secure the circuit board by pushing down near each of the supports. The support tips will snap into position, securing the circuit board.
- (NOTE) The terminating resistance connector is not attached to a new machine motor circuit board. When replacing the machine motor circuit board with a new one, be sure to remove it from the one replaced.
- (NOTE) Be sure to set the rotary switch to 1.

8-2-3. Replacing the power supply circuit board

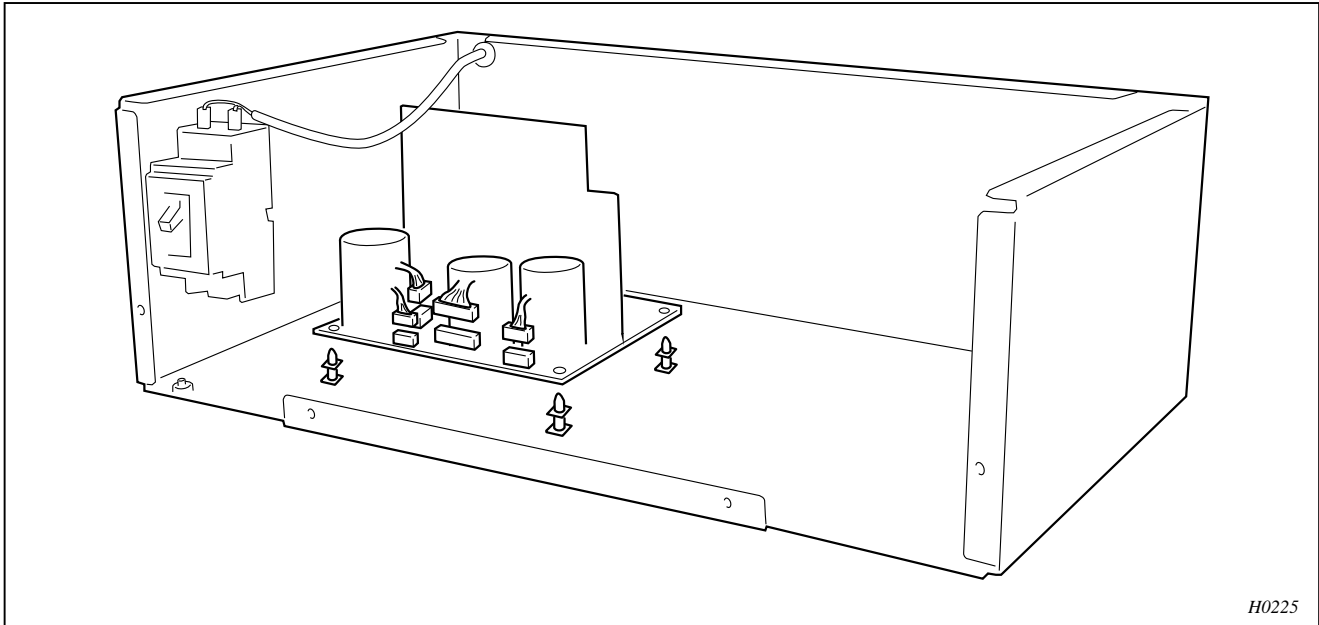

1. Remove all connectors of the power supply circuit board.
2. Remove the power supply circuit board while pressing the clamps of four circuit board supports inward.
3. Match the holes in the power supply circuit board with the circuit board supports, and connect the power supply circuit board to the base by pressing it next to each support.

(NOTE) When removing and reattaching connectors, be careful with them; do not pull on the wires.

(NOTE) Before removing and reattaching the circuit board, turn off the power, leave it as is for at least 5 minutes, and make sure that electrical charge of the capacitor on the circuit board has been released. Measurement should be taken across the terminals of connector P1; the voltage should be 1V or less.

(NOTE) Since an electrical charge may remain in the removed power supply circuit board, do not touch the bottom (soldered surface) of the circuit board and anything lead in part. As well, pay attention not to cause a short by putting the circuit board on anything metal.

8-2-4. Replacing the panel PCB

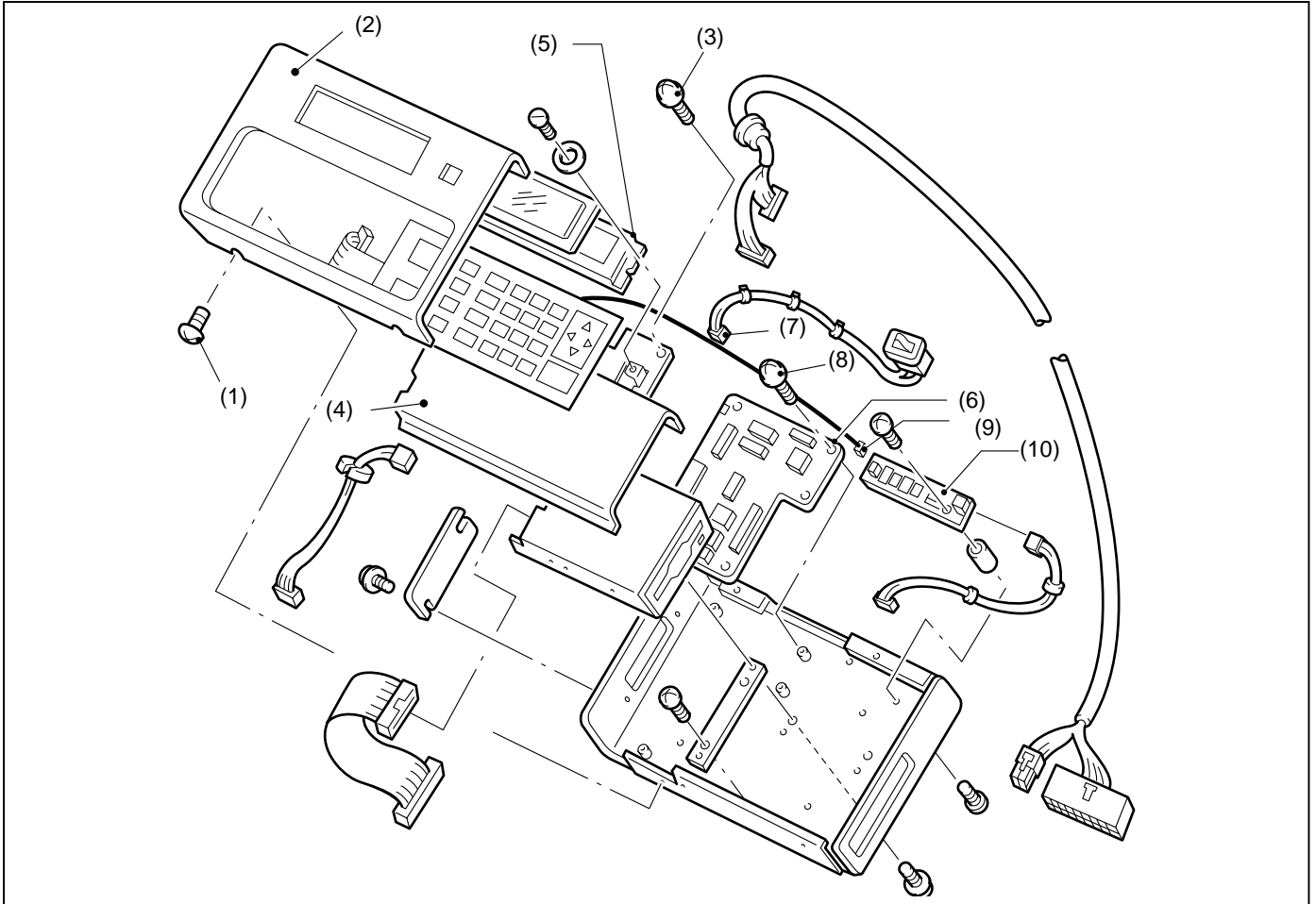

1. Loosen the four screws (1) securing the panel at the top and bottom, and lift the panel cap (2) by opening it from the key sheet side.
2. Remove two screws (3) and float the key sheet support (4) to disconnect the flat cable connecting the LCD (5) with the panel PCB (6).
3. Open the key sheet support (4) from the right end and disconnect the flat cable connecting the key sheet with the panel PCB (6). Remove the cable (9) connected the LCD(5) to the LCD Back light circuit board. Remove the key sheet support (4).
4. Disconnect the harness connector (7) connected to the switch on the operation panel and remove the panel cap (2).
5. Disconnect all the connectors connected to the panel PCB (6).
6. Remove five screws (8) and remove the panel PCB (6).
7. Replace the panel PCB (6) with a new one.

(MEMO) Reassemble the operation panel by reversing this procedure.

(NOTE) Be sure to reconnect all the cables after replacing the panel PCB (6).

(NOTE) When connecting or disconnecting cables, be sure to hold the connectors but do not pull on the cables.

(NOTE) Connect or disconnect the flat cable while holding it perpendicular to the connector. Especially avoid connecting the cable to the connector at a slant.

8-2-5. Replacing the control panel

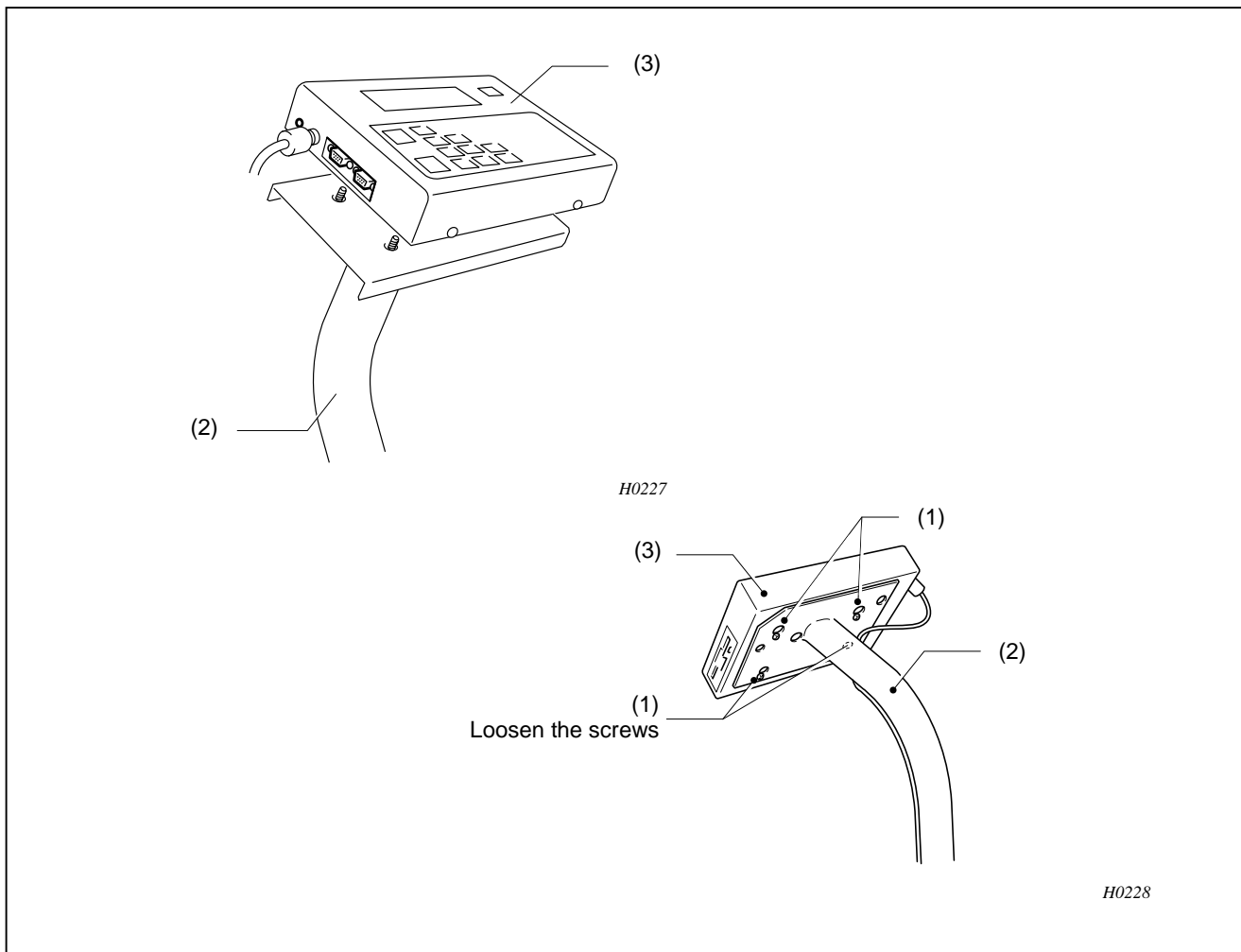

When replacing the whole control panel, follow the procedures below. Loosen the four screws (1) on the back side of the control panel (3). Then remove it from the arm (2). At this time, be careful not to drop the control panel (3).

(MEMO) When assembling, reverse the above procedure.

8-2-6. Replacing the TR breakage sensor PCB

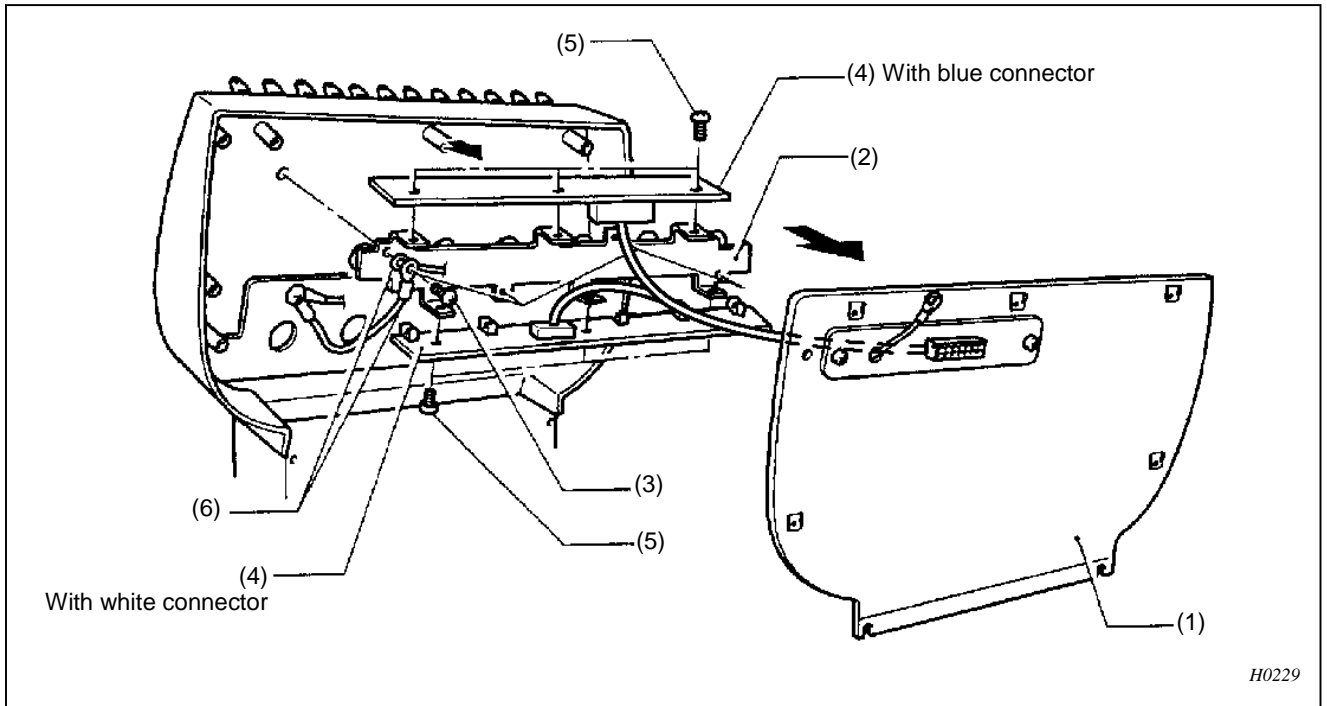

1. Remove the adjustment base cover (1).
2. Remove the four screws (3) securing the thread breakage plate (2).
3. Remove the thread breakage plate (2) and the TR breakage sensor PCBs (4) from the adjustment base cover (1).
4. Remove the connectors. Remove the six screws (5) securing the TR breakage sensor PCBs (4) to the thread breakage plate (2).
5. Remove the TR breakage sensor PCBs (4).

(MEMO) Reverse the above procedure for re-assembly.

(NOTE) Attach the ground wire (6) to the thread breakage plate (2) using the four screw (3).

(NOTE) After replacing the PCB, be sure to attach the ground wire (6) and connectors.

(NOTE) When removing and reattaching connectors, do not pull on the cables; hold the connectors.

(NOTE) The blue and the white connectors are attached to the upper and lower TR breakage sensor PCBs (4), respectively.

8-3. Fuses

8-3-1. Position of fuses

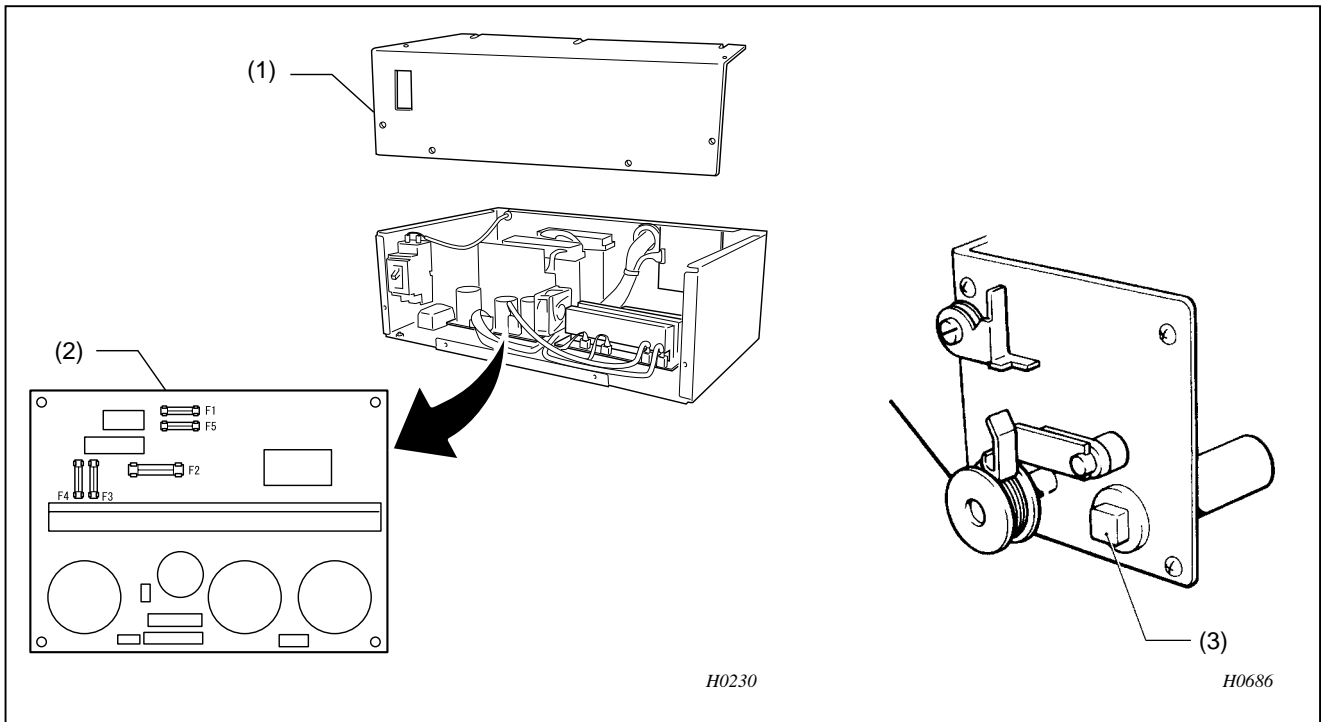

1. Remove cover (1).
2. There is a fuse holder in front of the transformer in the power supply unit (2). Five fuses are fixed in the fuse holder.

(NOTE) Be sure to turn off the power before replacing a fuse.

8-3-2. Fuse type and capacity

No.	Fuse type & capacity	Part code
F1, F5	Fuse 5A (Slow blow fuse)	415814001
F2	Fuse 15A (Glass tube fuse)	S02887000
F3	Fuse 5A (Slow blow fuse)	415814001
F4	Fuse 5A (Slow blow fuse)	415814001

(NOTE) Be sure to use only fuses of authorized types and capacities.

(NOTE) While the circuit protector (3) is activated, the thread winding motor will not rotate. Let the protector cool for a while before pushing it back. (Otherwise, it may trip again.)

8-3-3. Replacing fuse

(NOTE) The problems are listed below for your reference to replace a fuse.

(NOTE) Use the same type and rating of a fuse to replace.

(NOTE) Tighten a fuse socket securely when you replace a fuse.

Fuse No.	Problem
F1, F5	Sewing machine motor does not run at all. Overload.
F2	- X and Y carriages do not move at all. Home position detection error occurs. - Solenoid does not operate. (Thread trimmer does not function)
F3	- Needle bar case locking. - Bobbin winder motor does not operate. - Looling fan does not rotate. Fan motor error occurs.
F4	Operation panel display is blank and the sewing machine does not operate.

8-4. About P-ROM (BES-116AC, 916AC, 1216AC)

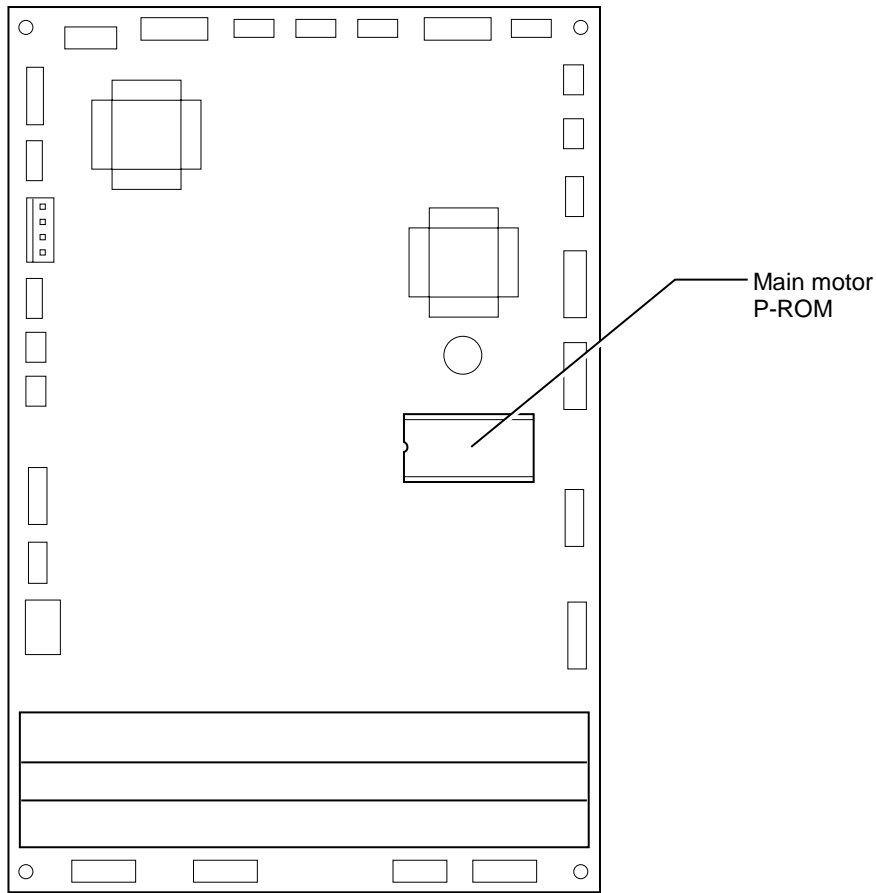

H0231

Main PCB

- (NOTE) Be sure to turn off the power before replacement.
- (NOTE) Use care when handling the P-ROMs.
Make sure the pins are properly inserted in the sockets.
- (NOTE) Do not apply excessive force when mounting the PROM on the circuit board.
- (NOTE) Confirm that the P-ROMs are in the correct position and direction.
- (NOTE) Use of the special PRMO removal tool is recommended when removing the PROM. If a screwdriver must be used, be careful not to damage the PROM socket and the circuit board. Carefully lift the PROM little by little from both sides. See the figure.

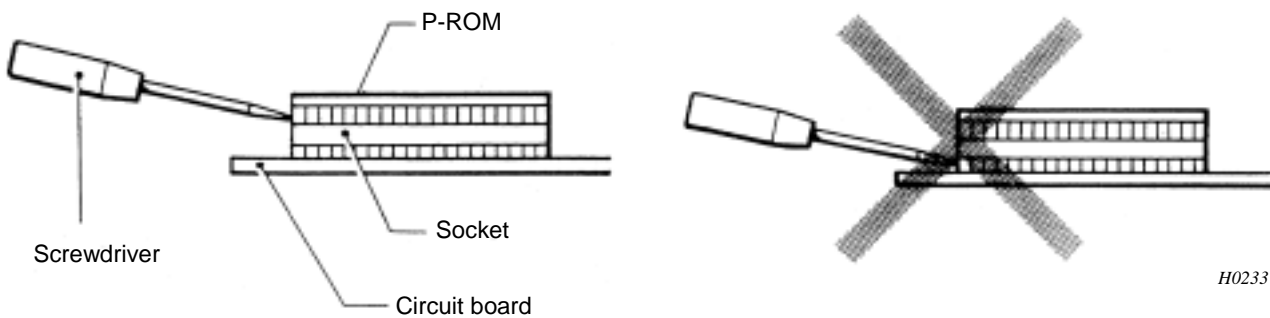

H0232

H0233

8-5. Connectors

8-5-1. Min circuit board connectors

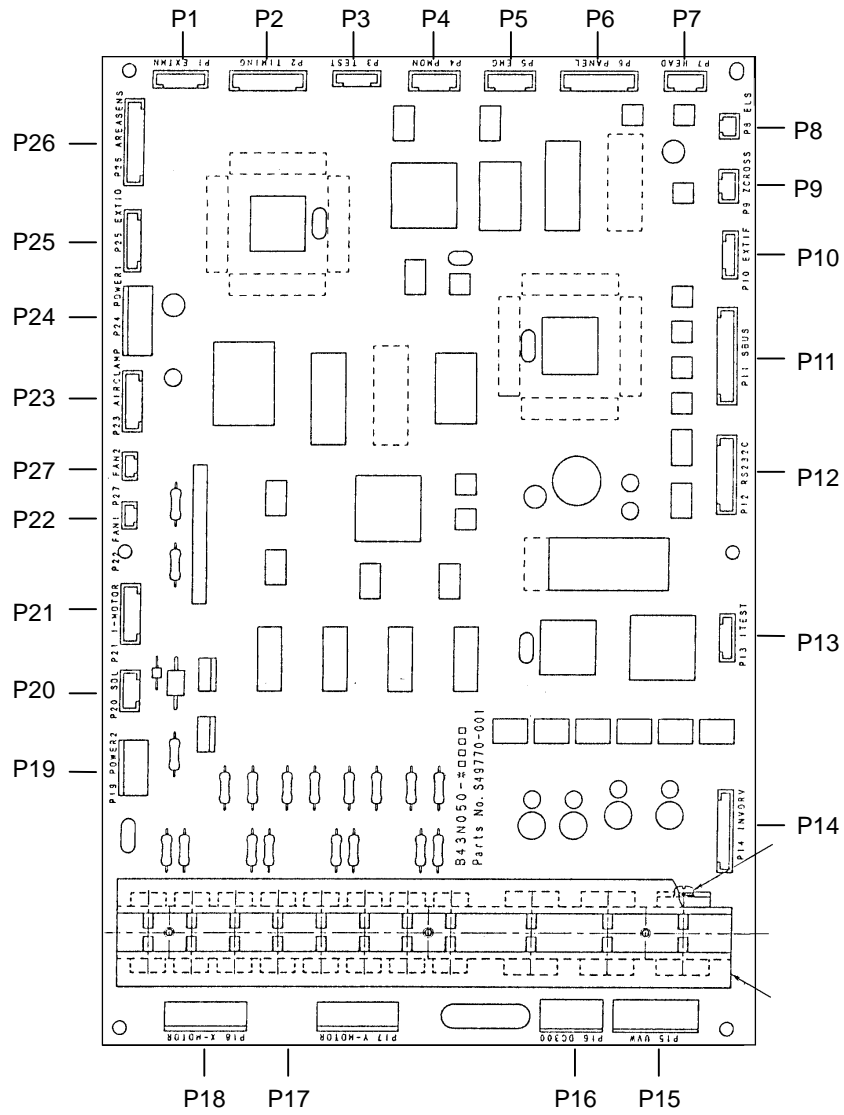

H0234

Connector No.	Connecting point	Drive signals	Symptoms resulting from bad connection
P2	Main circuit board - Rotary encoder - Stop position sensor	- Timing pulse motor signal - Synchronize signal - Stop position signal	- Hoop does not move during sewing. - Thread trimmer does not function correctly. - Pulley does not stop at correct position when machine motor is stopped.
P7	Main circuit board - Head PCB	- Head PCB communication signal	- Needle bar case does not move correctly. - Wiper does not retract. - Thread breakage error occurs when the thread is not broken. - Thread trimmer does not function correctly. - Machine does not operate.
P9	Main circuit board - Power transformation	- AC18V	- Power supply frequency error occurs. - Blackout error occurs.
P12	Main circuit board - Control panel	- Operation keyboard control signal	- Nothing happens after power is turned on. - Display is blank.
P14	Main circuit board - Power transformation	- AC14V	- Main shaft motor does not rotate. - Thread trimmer does not function correctly. - Motor lock occurs
P15	Main circuit board - Main shaft motor	- Motor output(UVW)	- Main shaft motor does not rotate. - Thread trimmer does not function correctly. - Motor lock occurs
P16	Main circuit board - Power supply circuit board	- Main shaft motor DC power	- Main shaft motor does not rotate. - Thread trimmer does not function correctly. - Motor lock occurs
P17	Main circuit board - Y-pulse motor	- Y-pulse motor driving power supply	- Y home position cannot be detected when power is turned on. - Unbalanced pattern
P18	Main circuit board - X-pulse motor	- X-pulse motor driving power supply	- X home position cannot be detected when power is turned on. - Unbalanced pattern

Connector No.	Connecting point	Drive signals	Symptoms resulting from bad connection
P19	Main circuit board - Power supply circuit board	- +5V(Whole main circuit board) - +24V (Pulse motor for needle replacement)	- Control function does not operate well, or does not operate at all. - Pulse motor for needle bar replacing does not run.(Needle bar does not move.)
P20	Main circuit board - solenoid	- Solenoid drive output	- Pressor foot solenoid and thread breakage solenoid does not operate.
P21	Main circuit board - Pulse motor for needle bar replacement (Unused for the BAS-401)	- Pulse motor driving output for needle bar replacement	- Needle bar case locking - Improper needle bar case position
P22	Main circuit board - Exhaust Fan motor	- Exhaust fan power - Exhaust fan stop alarm signal	- Fan error occurs during embroidering.
P24	Main circuit board - Power supply circuit board	- +60V (X-Y pulse motor) - +60V(Solenoid)	- X-axis pulse motor does not run. - Y-axis pulse motor does not run. - Solenoid does not operate.
P26	Main circuit board - X home position sensor Main circuit board - Y home position sensor Main circuit board - Cap frame overtravel sensor	- X-axis center detection - Y-axis center detection - Mechanical area over signal	- When power is turned on, "area over" is displayed. - When power is turned on, "area over" is displayed. - When power is turned on, "area over" is displayed although the needle is in the sewing area. (Cap frame mode) - During sewing, "area over" is displayed although the needle is in the sewing area. (Cap frame mode)
P27	Main circuit board - Cooling fan	- Cooling fan power - Cooling fan stop alarm signal	- Fan error occurs during embroidering.

Unused connector No.	P1,P3,P4,P5,P6,P8,P10,P11,P13	Do not connect any cable
----------------------	-------------------------------	--------------------------

Optional connector

P5	Main circuit board - Emergency stop SW	- Emergency stop signal	- Machine does not stopped when emergency stop SW is pushed
P23	Main circuit board - Air clamp SW - Air clamp valve	- Air clamp ON/OFF signal	- Mode is not changed to air clamp mode. - Air clamp frame does not rise or descent.

Short connector

P5	Main circuit board - Short connector		"Release Stop SW" error occurs.
P25	Main circuit board - Short connector		- The message "Cooling fan error" may be displayed.

8-5-2. Power supply circuit board connectors

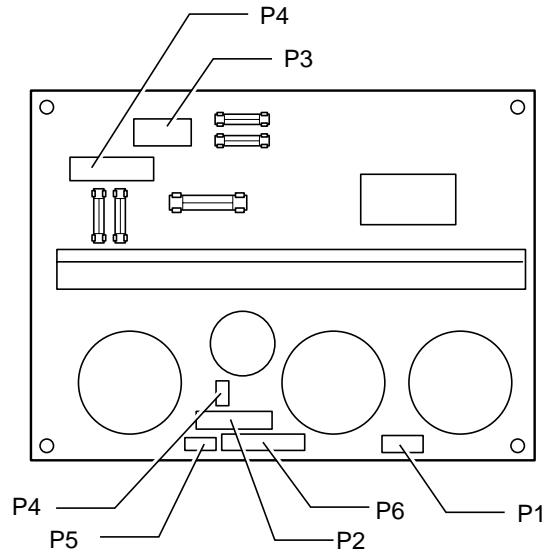

H0235

Connector No.	Connecting point	Drive signals	Symptoms resulting from improper Connection or breakage
P1	Power supply circuit board - Main circuit board (P16)	- Totally enclosed 3-phase motor DC power supply	- Totally enclosed 3-phase motor does not rotate. - Thread trimmer does not function. - Motor is locked.
P2	Power supply circuit board - Main circuit board (P19,P24)	- XY-pulse motor driving power supply - Solenoid driving power supply - Pulse motor driving Power supply - Main circuit board power supply	- X and Y home position cannot be detected when power is turned on. - Solenoid does not work. - Needle bar case is locked. - Control function does not operate well, or does operate at all.
P3	Power supply circuit board - Transformer	- X-pulse motor AC power supply - Y-pulse motor AC power supply - Solenoid AC power supply - Main circuit board AC power supply - Pulse motor driving power supply	- X and Y home position cannot be detected when power is turned on. - Solenoid does not work. - Control function does not work. - Needle bar case is locked.
P4	Power supply circuit board - Bobbin winder (optional)	- Bobbin winder motor driving power supply	- Bobbin winder motor does not rotate.
P5	Power supply circuit board - Control panel	- Control panel power	- Machine does not operate
P6	Power supply circuit board - Head PCB	- Head PCB control power	- Thread trimmer does not function correctly. - Machine does not operate.
P7	Power supply circuit board - Transformer	- Totally enclosed 3-phase motor AC power supply	- Totally enclosed 3-phase motor does not rotate. - Thread trimmer does not function. - Motor is locked.

8-5-3. Head PCB connectors

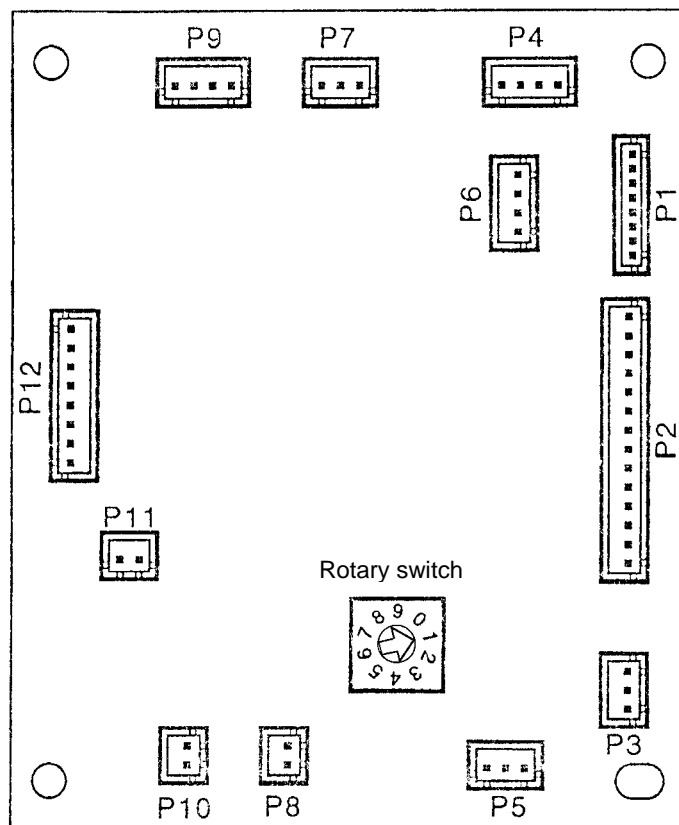

H0236

Set the rotary switch to 1.

Connector No.	Connecting point	Drive signal	Symptoms resulting from Improper connection or breakage
P1	Unused	- Power LED	Head LED is not lit.
P2	Head PCB – TR breakage sensor PCB	- Sensor selection signal - Sensor signal	Thread breakage detection often happens.
P3	Unused		
P4	Head PCB – Main PCB	- Communication line	Machine does not operate.
P5	Head PCB – Wiper sensor (Unused in BES-116AC)	- Wiper sensor	When wiper has not retracted properly, it is not regarded as an error.
P6	Head PCB – Terminating resistance connector		Machine does not operate. Communication error “E*” may be displayed
P7	Head PCB – Potentiometer	- Potentiometer	Error “Needle bar case lock” appears when power is turned on.
P8	Head PCB – Picker solenoid	- Picker solenoid out put	Picker solenoid does not operate.
P9	Unused		
P10	Head PCB – Jump solenoid	- Jump solenoid output	Needle bar does not jump.
P11	Head PCB – Wiper solenoid	- Wiper solenoid output	Wiper does not work. (NOTE) No error code appears.
P12	Head PCB – Power supply PCB	- +60V, +24V, +5V power supply	Machine does not operate.

8-5-4. Panel PCB connectors

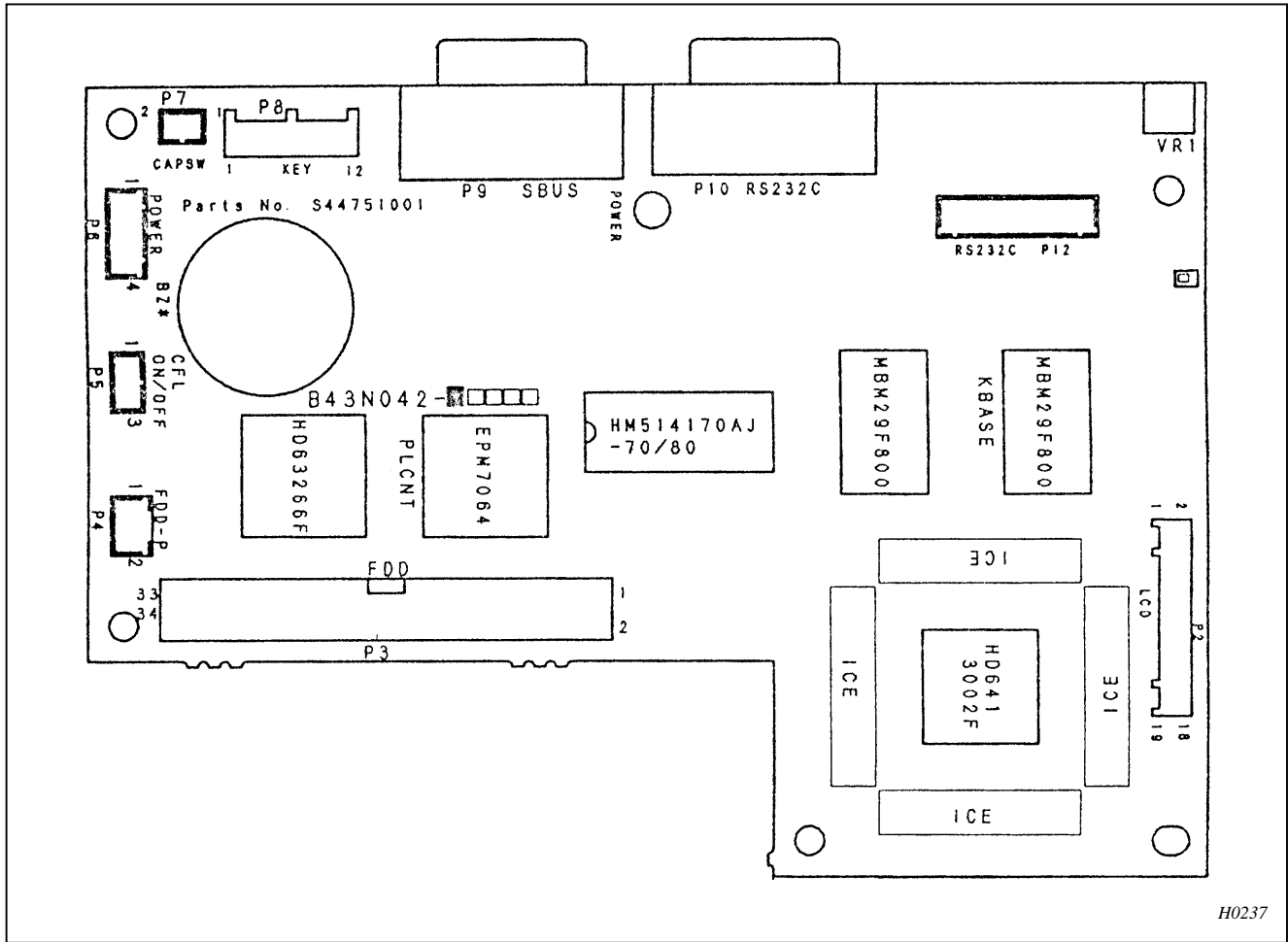





























Connector No.	Connecting point	Main signals	Symptoms resulting from Improper connection or breakage
P1	Not used		
P2	LCD unit(LCD)	- Control signal	The floppy disk cannot be read.
P3	Floppy disk drive	- Control signal	Nothing is displayed on LCD.
P4	Floppy disk drive	- +5V power supply	The floppy disk cannot be read.
P5	Power PCB for backlighting	- +5V power supply - Backlight ON/OFF signal	Backlighting LCD does not light.
P6	Control box	- +5V power supply	Backlighting LDC does not light. Nothing is displayed on LCD.
P7	Switch for cap frame	- +5V power supply	The setting is not switched to the hat hoop even if the power is turned on after it is switched to the hat hoop side.
P8	Sheet key switch	- Switch signals	Key operation is disabled.









Connector No.	Connecting point	Main signals	Symptoms resulting from Improper connection or breakage
P9	Not used (This is not used in this specification.)		
P10	Not connected(This is used when connecting to the PC.)	RS232C	
P11	Not connected	RS232C	
P12	Main PCB	RS232C	The initial screen remains displayed.
P13-16	Not connected		

9. Error code list

BES-116AC

Code	Error Messages	Error	Measures
E-00	ERROR 00	NO error occurs.	
E-01	ERROR 01	Either motor of main shaft, X- or Y-axis has locked.	This is not usually displayed.
E-02	Overtravel	Overtravel occurs during home position detecting movement.	Turn the power off and on once. If the same error occurs again, the area sensor is faulty.
E-03	Stop SW was pressed during home positioning	The stop switch is pressed during home position detecting movement.	Press the  to restart the home position detecting movement again.
E-04	Zero positioning is out of range	Zero detecting movement out of range	Turn the power off and on once. If the same error occurs again, the home position sensor is faulty.
E-05	Needle stop position error	Needle stop position error	Adjust the pulley stop position (100 degrees) above the needle and press the  .
E-09	X-axis home position error	X-axis home position detection error	Turn the power off and on once. If the same error occurs again, the X-axis mechanism is faulty.
E-0A	Thread breakage error	Thread breaking error	After passing through the thread, press the  .
E-0B	ERROR 0B	Stop or emergency stop during sewing	This is not usually displayed.
E-0C	ERROR 0C	Insufficient bobbin thread	
E-0D	ERROR 0D	The machine does not return to the home position.	
E-0F	ERROR 0F	Undefined error	
E-14	Y-axis home position error	Y-axis home position error	Turn the power off and on once. If the same error occurs again, the Y-axis mechanism is faulty.
E-15	Press  for restart.	Stop error during SSP processing (when pressing the stop key while the hoop is moving)	Hoop movement restarts if you press  .
E-16	ERROR 16	Needle with specified number is out of movable area.	This is not usually displayed.
E-17	ERROR 17	Speed Vol. No. is out of range.	
E-1A	ERROR 1A	Destination coordinates error	This is not usually displayed.







Code	Error Messages	Error	Measures
E-1C	Restart perimeter	The machine stops during mask tracing.	Tracing is cancelled if the  key is pressed when the machine is stopped during mask tracing. Press the  key to continue tracing.
E-1D	Stop while transferring to next repeat pattern	The machine stops while the needle is moving between patterns during repeat sewing	This is displayed when the stop switch is pressed while the hoop is moving. Press the  to move the hoop again. (It is necessary to press the  again to start sewing.)
Errors E-1C and E-1D are not displayed due to mechanical problems.			
E-21	Area over 	Hoop overhang(+X)	Pattern or the needle position is out of the embroidering area. Reset the embroidering area on the panel or move the hoop to the sewable position.
E-22	Area over 	Hoop overhang(+Y)	
E-23	Area over 	Hoop overhang(+X, +Y)	
E-24	Area over 	Hoop overhang(-X)	
E-25	Area over 	Hoop overhang(+X, -X)	
E-26	Area over 	Hoop overhang(-X, +Y)	
E-27	Area over 	Hoop overhang(+X, -X, +Y)	
E-28	Area over 	Hoop overhang(-Y)	
E-29	Area over 	Hoop overhang(+X, -Y)	
E-2A	Area over 	Hoop overhang(+Y, -Y)	
E-2B	Area over 	Hoop overhang(+X, +Y, -Y)	
E-2C	Area over 	Hoop overhang(-X, -Y)	
E-2D	Area over 	Hoop overhang(+X, -X, -Y)	
E-2E	Area over 	Hoop overhang(-X, +Y, -Y)	
E-2F	Area over 	Hoop overhang(+X, -X, +Y, -Y)	
E-31	Area over 	Needle overhang(+X)	
E-32	Area over 	Needle overhang(+Y)	
E-33	Area over 	Needle overhang(+X, +Y)	
E-34	Area over 	Needle overhang(-X)	
E-36	Area over 	Needle overhang(-X, +Y)	





















Code	Error Messages	Error	Measures
E-38	Area over 	Needle overhang(-Y)	Pattern or the needle position is out of the embroidering area. Reset the embroidering area on the panel or move the hoop to the sewable position.
E-39	Area over 	Needle overhang(+X, -Y)	
E-3C	Area over 	Needle overhang(-X, -Y)	
E-41	This function is not supported. Turn off the power	Invalid start-up error	Turn the power off and on once.
E-42	ERROR 42	XY movement error	Press the  .
E-43	Slave I/F EEPROM read error	Slave I/F EEPROM read error	Turn the power off and on once. If the same error occurs again, the main PC is faulty.
E-A1	Main (Z) motor lock	Spindle motor lock	Press the  . If it occurs frequently, the main shaft mechanism is faulty.
E-A5	ERROR A5	Spindle motor CPU error	This is not usually displayed.
E-A6	ERROR A6	Main shaft motor CPU communication command error	
E-A7	ERROR A7	Main shaft motor CPU send/receive error	
E-A8	ERROR A8	Main shaft stop position signal error	Adjust the pulley stop position (100 degrees) above the needle and press the  . If the error occurs frequently, the parts related to the main shaft stop position sensor are faulty.
E-A9	Spindle CPU parameter error	Spindle CPU parameter error	This is not usually displayed.
E-BA	Power supply frequency error	Power supply frequency error	Turn the power off and on once. If the same error occurs again, the main PCB is faulty. And check the connection of connector P9.
E-C1	ERROR C1	Area over during embroidering	Set the embroidering area again on the panel.
E-C3	ERROR C3	Embroidering data buffer empty	This is not usually displayed.
E-C9	Embroidering start error	Embroidering start error	
E-CA	ERROR CA	No sewing permission	
E-CB	Spindle rotation speed error	Spindle rotation speed error	Press the  to cancel the error and press the  . If the same error occurs again, there is a possibility that the spindle is overloaded.

Code	Error Messages	Error	Measures
E-CD	ERROR CD	Speed command can not be received.	Turn the power off and on once. If the same error occurs again, the main PCB is faulty.
E-E3	Exhaust fan motor stop	Cooling fan motor stop.	Turn off the power and check the fan harness. Turn on the power again. If the same error occurs again, the fan or the main PCB is faulty.
E-E5	ERROR E5	Over-run error during interfacing to main PCB CPU	This is not usually displayed.
E-E6	ERROR E6	Framing error during interfacing to main PCB CPU	
E-E7	ERROR E7	Parity error during interfacing to main PCB CPU	
E-E8	ERROR E8	Receiving time up error during interfacing to main PCB CPU	
E-E9	ERROR E9	Send/Receive inconsistent error during interfacing to main PCB CPU	
E-EA	ERROR EA	ACK code receiving error during interfacing to main PCB CPU	
E-EB	ERROR EB	Send/Receive ID code error during interfacing to main PCB CPU	
E-EC	ERROR EC	Send data checksum error during interfacing to main PCB CPU	
E-ED	ERROR ED	Data empty error during interfacing to main PCB CPU	
E-EF	ERROR EF	Receiving error on interface	
E-F1	ERROR F1	Send time up error	
E-F2	ERROR F2	Request-to-waiting time up error	
E-F3	ERROR F3	Request-to-receive time up error	
E-F4	ERROR F4	Receive command error	
E-F5	ERROR F5	NACK code receiving error	
E-F6	ERROR F6	Data requested for needle position can not be returned.	
E-F7	ERROR F7	It is not receive command for the request one.	
E-F8	ERROR F8	PRE code error	
E-F9	ERROR F9	No applicable command	



Code	Error Messages	Error	Measures
E-FA	ERROR FA	Interface receive data sum check error	This is not usually displayed.
E-FB	ERROR FB	Send time up error	
E-FF	ERROR FF	No status is returned from main shaft CPU.	

BES-916AC, 1216AC

Code	Error messages	Error	Measures
E-00	ERROR 00	No error occurs.	This is not usually displayed.
E-01	ERROR 01	Either motor of main shaft, X- or Y-axis has locked.	
E-02	Overtravel	Overtravel occurs during home position detecting movement.	Turn the power off and on once. If the same error occurs again, the area sensor is faulty.
E-03	Stop SW was pressed during home positioning	The stop switch is pressed during home position detecting movement.	Press the  to restart the home position detecting movement again.
E-04	Zero positioning is out of range	Zero detecting movement out of range	Turn the power off and on once. If the same error occurs again, the home position sensor is faulty.
E-05	Needle stop position error	Needle stop position error	Adjust the pulley stop position (100 degrees) above the needle and press the  .
E-06	Needle bar case position error	Needle bar case position error	This is not usually displayed.
E-07	Needle case lock	Needle bar case lock	Press the  . If the same error occurs again, the color change mechanism is faulty.
E-08	Stop while needle bar case transferring	Stop switch or emergency switch was pressed while the needle bar case is traveling.	This is not usually displayed.
E-09	X-axis home position error	X-axis home position detection error	Turn the power off and on once. If the same error occurs again, the X-axis mechanism is faulty.
E-0A	Thread breakage error	Thread breaking error	After passing through the thread, press the  .
E-0B	ERROR 0B	Stop or emergency stop during sewing	This is not usually displayed.
E-0C	ERROR 0C	Insufficient bobbin thread	
E-0D	ERROR 0D	The machine does not return to the home position.	
E-0F	ERROR 0F	Undefined error	
E-14	Y-axis home position error	Y-axis home position error	Turn the power off and on once. If the same error occurs again, the Y-axis mechanism is faulty.
E-15	Press  for reatart.	Stop error during SSP processing (when pressing the stop key while the hoop is moving)	Hoop movement restarts if you press  .
E-16	ERROR 16	Needle with specified number is out of movable area.	This is not usually displayed.

Code	Error messages	Error	Measures
E-17	ERROR 17	Speed Vol. No. is out of range.	This is not usually displayed.
E-1A	ERROR 1A	Destination coordinates error	
E-1C	Restart perimeter	The machine stops during mask tracing.	Tracing is cancelled if the  key is pressed when the machine is stopped during mask tracing. Press the  key to continue tracing.
E-1D	Stop while transferring to next repeat pattern	The machine stops while the needle is moving between patterns during repeat sewing.	This is displayed when the stop switch is pressed while the hoop is moving. Press the  to move the hoop again. (It is necessary to press the  again to start sewing.)
Errors E-1C and E-1D are not displayed due to mechanical problems.			
E-1F	Presser foot down error	Presser foot down error while searching for home position just after the power is turned on.	Press the  . If the same error occurs again, adjust the presser foot switch.
E-21	Area over 	Hoop overhang(+X)	Pattern or the needle position is out of the embroidering area. Reset the embroidering area on the panel or move the hoop to the sewable position.
E-22	Area over 	Hoop overhang(+Y)	
E-23	Area over 	Hoop overhang(+X, +Y)	
E-24	Area over 	Hoop overhang(-X)	
E-25	Area over 	Hoop overhang(+X, -X)	
E-26	Area over 	Hoop overhang(-X, +Y)	
E-27	Area over 	Hoop overhang(+X, -X, +Y)	
E-28	Area over 	Hoop overhang(-Y)	
E-29	Area over 	Hoop overhang(+X, -Y)	
E-2A	Area over 	Hoop overhang(+Y, -Y)	
E-2B	Area over 	Hoop overhang(+X, +Y, -Y)	
E-2C	Area over 	Hoop overhang(-X, -Y)	
E-2D	Area over 	Hoop overhang(+X, -X, -Y)	
E-2E	Area over 	Hoop overhang(-X, +Y, -Y)	
E-2F	Area over 	Hoop overhang(+X, -X, +Y, -Y)	

Code	Error messages	Error	Measures
E-31	Area over	Needle overhang(+X)	Pattern or the needle position is out of the embroidering area. Reset the embroidering area on the panel or move the hoop to the sewable position.
E-32	Area over	Needle overhang(+Y)	
E-33	Area over	Needle overhang(+X, +Y)	
E-34	Area over	Needle overhang(-X)	
E-36	Area over	Needle overhang(-X, +Y)	
E-38	Area over	Needle overhang(-Y)	
E-39	Area over	Needle overhang(+X, -Y)	
E-3C	Area over	Needle overhang(-X, -Y)	
E-41	This function is not supported. Turn off the power	Invalid start-up error	Turn the power off and on once.
E-42	ERROR 42	XY movement error	Press the
E-43	Slave I/F EEPROM read error	Slave I/F EEPROM read error	Turn the power off and on once. If the same error occurs again, the main PC is faulty.
E-A1	Main (Z) motor lock	Spindle motor lock	Press the . If it occurs frequently, the main shaft mechanism is faulty.
E-A5	ERROR A5	Spindle motor CPU error	This is not usually displayed.
E-A6	ERROR A6	Main shaft motor CPU communication command error	
E-A7	ERROR A7	Main shaft motor CPU send/receive error	
E-A8	ERROR A8	Main shaft stop position signal error	Adjust the pulley stop position (100 degrees) above the needle and press the . If the error occurs frequently, the parts related to the main shaft stop position sensor are faulty.
E-A9	Spindle CPU parameter error	Spindle CPU parameter error	This is not usually displayed.
E-BA	Power supply frequency error	Power supply frequency error	Turn the power off and on once. If the same error occurs again, the main PCB is faulty. And check the connection of connector P9.
E-C1	ERROR C1	Area over during embroidering	Set the embroidering area again on the panel.
E-C2	Wiper out error	Wiper out error	If the wiper is tangled with a thread, remove it. Press the .

Code	Error messages	Error	Measures
E-C3	ERROR C3	Embroidering data buffer empty	This is not usually displayed.
E-C9	Embroidering start error	Embroidering start error	
E-CA	ERROR CA	No sewing permission	
E-CB	Spindle rotation speed error	Spindle rotation speed error	Press the  to cancel the error and press the  . If the same error occurs again, there is a possibility that the spindle is overloaded.
E-CD	ERROR CD	Speed command can not be received.	Turn the power off and on once. If the same error occurs again, the main PCB is faulty.
E-E0	Cooling fan motor stop	Cooling fan motor stop	Turn off the power and check the fan harness. Turn on the power again. If the same error occurs again, the fan or the main PCB is faulty.
E-E3	Exhaust fan motor stop	Exhaust fan motor stop	
E-E5	ERROR E5	Over-run error during interfacing to main PCB CPU	This is not usually displayed.
E-E6	ERROR E6	Framing error during interfacing to main PCB CPU	
E-E7	ERROR E7	Parity error during interfacing to main PCB CPU	
E-E8	ERROR E8	Receiving time up error during interfacing to main PCB CPU	
E-E9	ERROR E9	Send/Receive inconsistent error during interfacing to main PCB CPU	
E-EA	ERROR EA	ACK code receiving error during interfacing to main PCB CPU	
E-EB	ERROR EB	Send/Receive ID code error during interfacing to main PCB CPU	
E-EC	ERROR EC	Send data checksum error during interfacing to main PCB CPU	
E-ED	ERROR ED	Data empty error during interfacing to main PCB CPU	
E-EF	ERROR EF	Receiving error on interface	
E-F1	ERROR F1	Send time up error	
E-F2	ERROR F2	Request-to-waiting time up error	

Code	Error messages	Error	Measures
E-F3	ERROR F3	Request-to-receive time up error	This is not usually displayed.
E-F4	ERROR F4	Receive command error	
E-F5	ERROR F5	NACK code receiving error	
E-F6	ERROR F6	Data requested for needle position can not be returned.	
E-F7	ERROR F7	It is not receive command for the request one.	
E-F8	ERROR F8	PRE code error	
E-F9	ERROR F9	No applicable command	
E-FA	ERROR FA	Interface receive data sum check error	
E-FB	ERROR FB	Send time up error	
E-FF	ERROR FF	No status is returned from main shaft CPU.	

10. Troubleshooting flowchart

10-1. Troubleshooting flowchart when the power is on

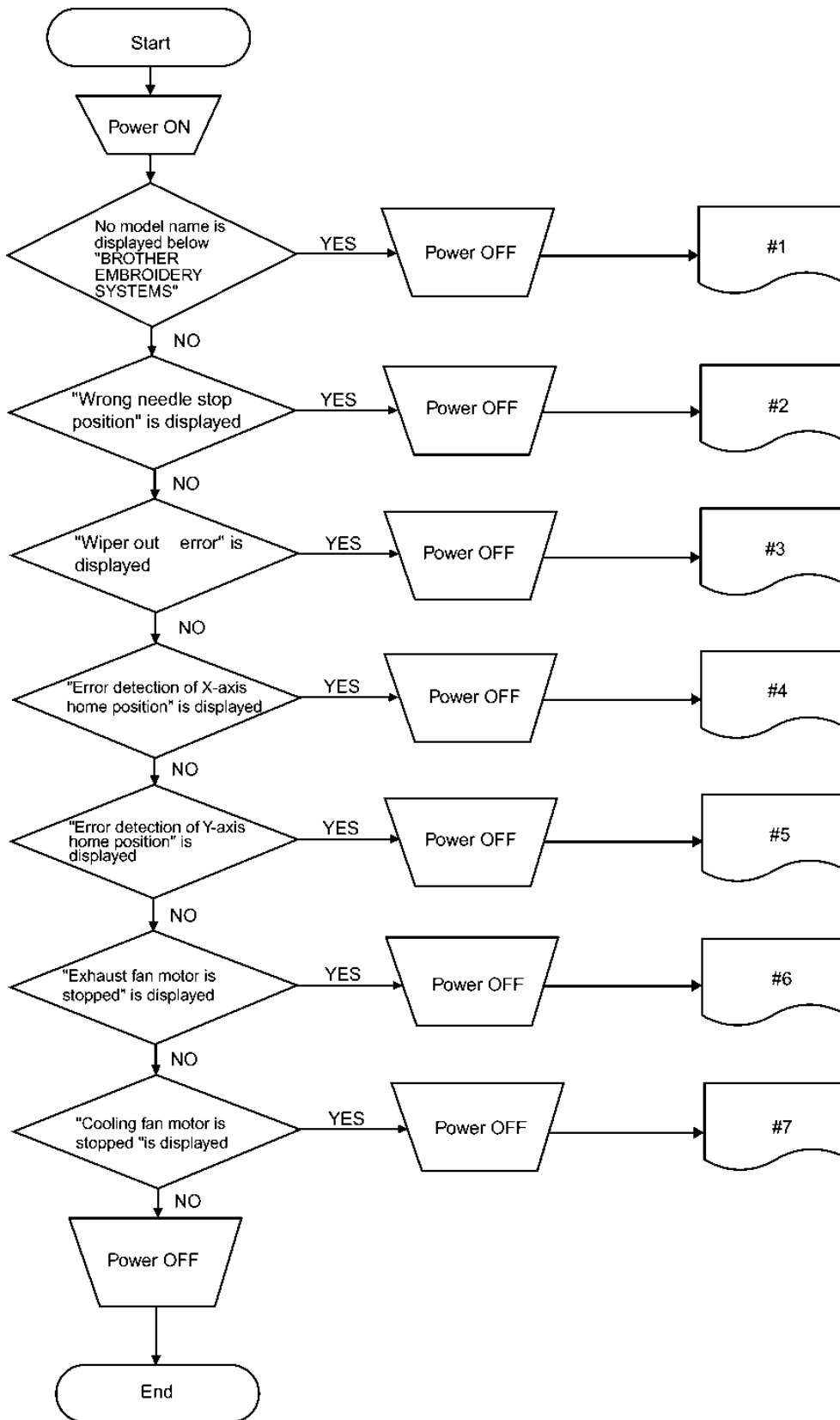

Check Item	Symptom	Check parts			
		Connector check	Energized harness	Board check	Other parts
#1	No model name is displayed below " BROT ER EMBROIDER Y S Y STEMS "	Main board:P12(RS232C) Control panel board:P11RS232C)	Floppy harness set	Main board Panel board	
#2	"Wrong needle stop position" is displayed	Stop position sensor board attached on the spindle pulley Main board:P2(TIMING)	Timing harness set	Main board Stop position sensor board	
#3	"Wiper out error" is displayed	Wiper sensor board attached on the rear internal wiper Head board:P5(WSENS)	Head sensor harness set	Wiper sensor board Head board	
#4	"Error detection of X-axis home position" is displayed	X-axis home position sensor board attached on the carriage Main board:P26(AREASENS)	XY area harness set	Main board X-axis home position sensor board	
		X-axis pulse motor connector Main board:P18(X-MOTOR)			X-axis pulse motor
		Main board:P19(POWER2) Power board:P2(MAIN)	Power harness MN set	Power board	Power board fuse:F2
#5	"Error detection of Y-axis home position" is displayed	Y-axis home position sensor board attached on the carriage Main board:P26(AREASENS)	XY area harness set	Main board	
		Y-axis pulse motor connector Main board:P17(X-MOTOR)			Y-axis pulse motor
		Main board:P19(POWER2) Power board:P2(MAIN)	Power harness MN set	Power board	Power board fuse:F2
#6	"Exhaust fan motor is stopped" is displayed	Cooling fan on the right of the heat sink on the main board Main board:P22(FAN1)	Power harness MN set	Main board	Cooling fan(right of the heat sink)
		Main board:P24(POWER1) Power board:P2(MAIN)	Power harness MN set	Power board	Power board fuse:F3
#7	"Cooling fan motor is stopped" is displayed	Cooling fan on the left of the heat sink on the main board Main board:P27(FAN2)	Power harness MN set	Main board	Cooling fan(left of the heat sink)
		Main board:P24(POWER1) Power board:P2(MAIN)	Power harness MN set	Power board	Power board fuse:F3

10-2. Troubleshooting flowchart in thread trimming operation

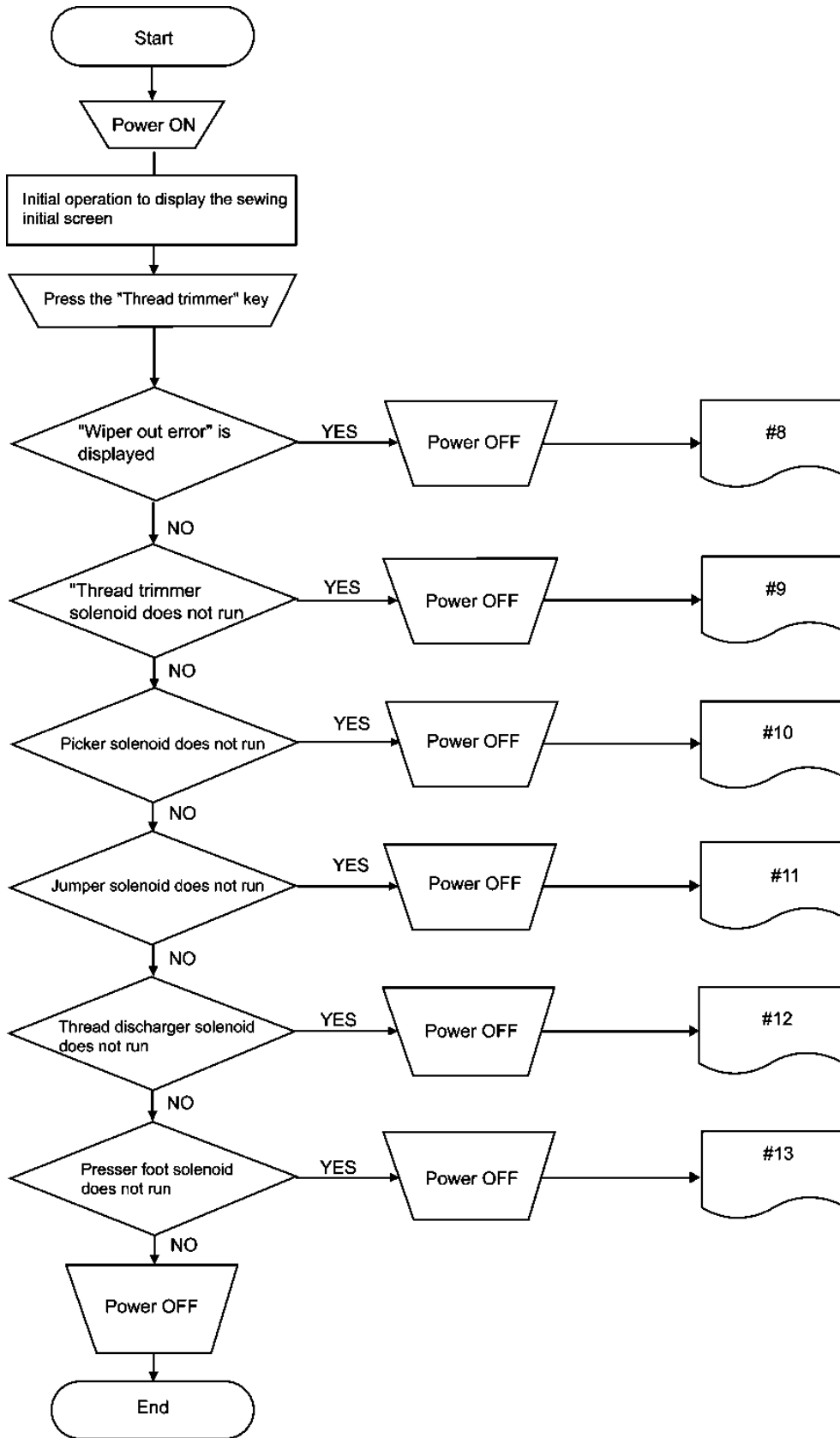

Check item	Symptom	Check parts			
		Connector check	Energized harness	Check board	Other parts
#8	"Wiper out error" is displayed	Wiper sensor board attached on the internal wiper Head board:P5(WSENS)	Sensor harness set of the head	Wiper sensor board Head board	
		Wiper solenoid of the head(W) Head board:P11(WIPER)	Solenoid harness set	Head board	Wiper (thread discharge) solenoid of the head Value of resistance:Approx.23Ω
#9	Thread trimmer solenoid does not run	Thread trimmer solenoid of the head(T) Main board:P20(SOL)	Solenoid harness set	Main board	Thread trimmer solenoid of head Value of resistance:Approx.30Ω
#10	Picker solenoid does not run	Picker solenoid of the head(P) Head board:P8(NDL)	Solenoid harness set	Head board	Picker solenoid of the head Value of resistance: Approx. 426Ω
#11	Jumper solenoid does not run	Jumper solenoid of the head(J) Head board:P10(JUMP)	Solenoid harness set	Head board	Jumper solenoid of the head Value of resistance:Approx.185Ω
#12	Thread discharger solenoid does not run	Wiper solenoid of the head(W) Head board:P11(WIPER)	Solenoid harness set	Head board	Wiper (thread discharge) solenoid of the head Value of resistance:Approx.23Ω
#13	Presser foot solenoid does not run	Presser foot solenoid of the head(F) Main board:P20(SOL)	Solenoid harness set	Main board	Presser foot solenoid of the head Value of resistance:Approx.81Ω

10-3. Troubleshooting flowchart in sewing operation (1)

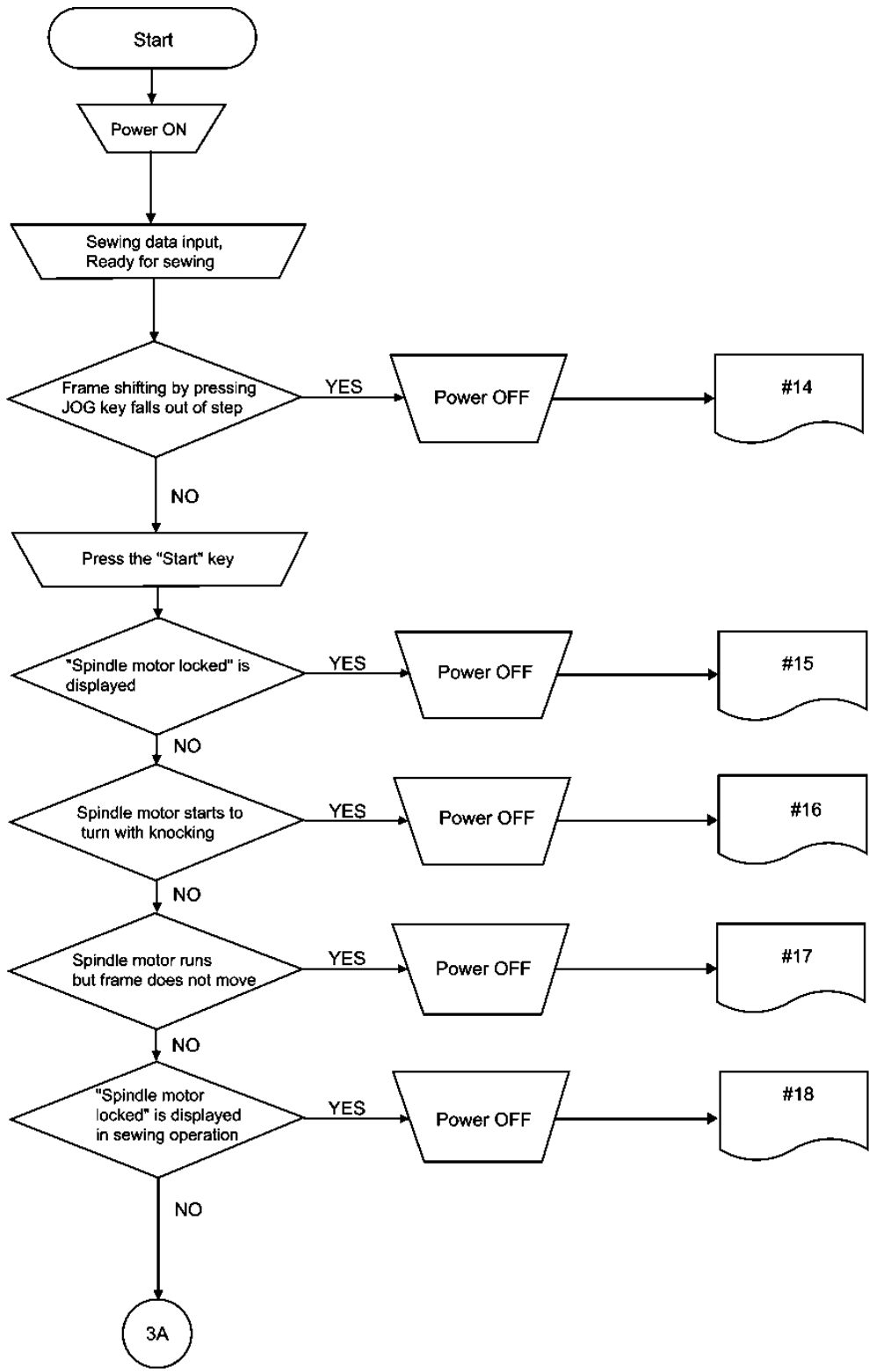

Check item	Symptom	Check parts			Other parts
		Connector check	Energized harness	Check board	
#14	Frame shifting by pressing JOG key falls out of step			Main board	
		X-axis pulse motor connector Main board:P18(X-MOTOR)			X-axis pulse motor
		Y-axis pulse motor connector Main board:P17(Y-MOTOR)			Y-axis pulse motor
#15	"Spindle motor locked" is displayed	Rotary encoder of the spindle pully Main board:P2(TIMING)	Timing harness set	Main board	Rotary encoder
#18	"Spindle motor locked" is displayed in sewing operation	Transformer(14V tap) Main board:P14(INVDRV)	Transformer harness M set		Transformer
		Main board:P16(DC300V) Power board:P1(INVERTER)	Power harness MT set	Main board Power board	Power board fuse:F1, F5
		Spindle motor Main board:P15(UVW)	Machine motor harness set	Main board	Spindle motor
#16	Spindle motor starts to turn with knocking	Transformer(14V tap) Main board:P14(INVDRV)	Transformer harness M set		Transformer
#17	Spindle motor runs but frame does not move	Rotary encoder of the spindle pully Main board:P2(TIMING)	Timing harness set	Main board	Rotary encoder
		X-axis pulse motor connector Main board:P18(X-MOTOR)		Main board	X-axis pulse motor
		Y-axis pulse motor connector Main board:P17(Y-MOTOR)		Main board	Y-axis pulse motor
		Main board:P19(POWER2) Power board:P2(MAIN)	Contorl panel board	Power board	Power board fuse:F2

10-4. Troubleshooting flowchart in sewing operation (2)

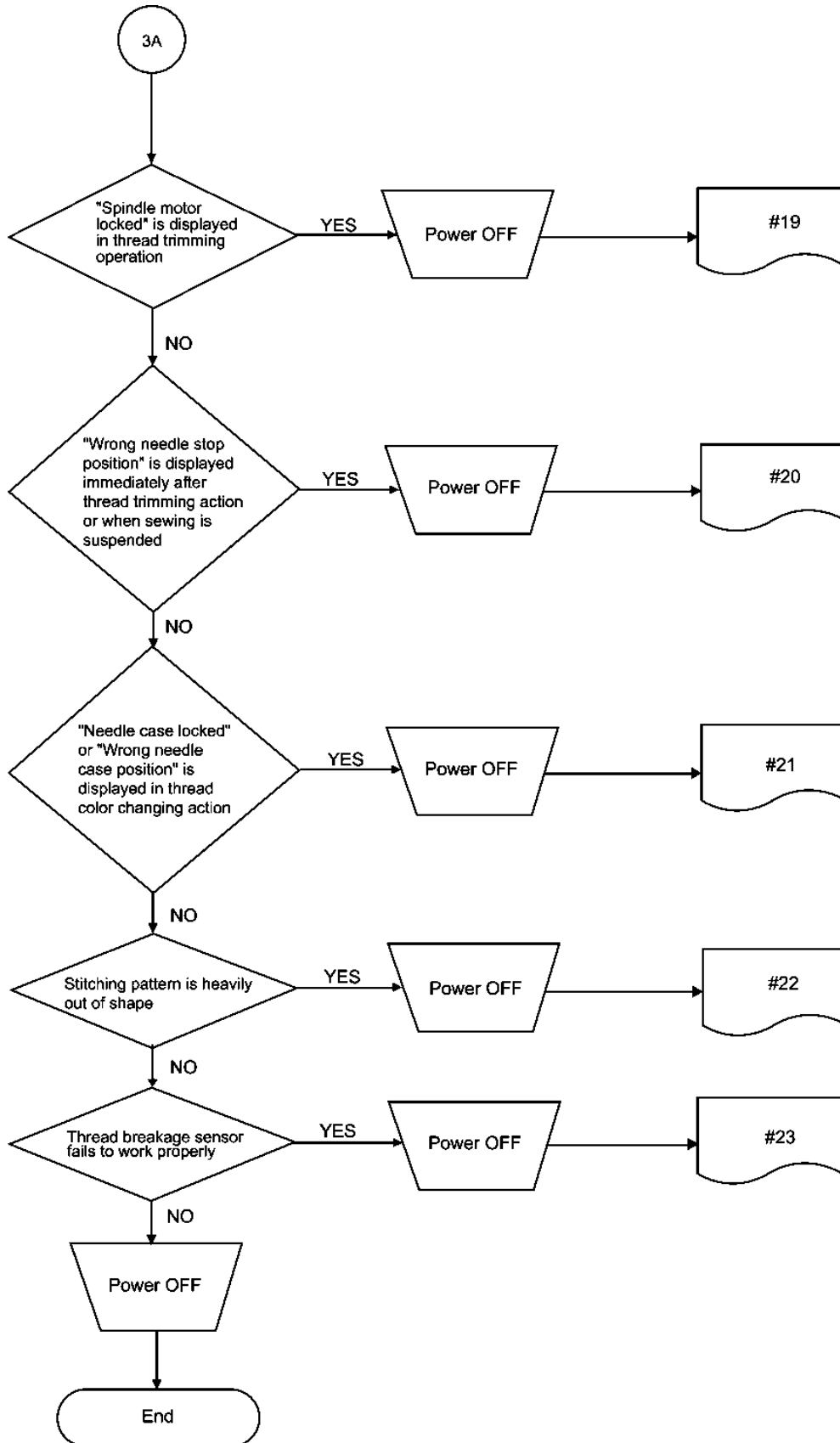

Check item	Symptom	Check parts			
		Connector check	Energized harness	Check board	Other parts
#19	"Spindle motor locked" is displayed in thread trimming operation	Rotary encoder of the spindle pully Main board:P2(TIMING)	Timing harness set	Main board	Rotary encoder
		Transformer (14V tap) Main board:P14(INVDRV)	Transformer harness M set		Transformer
		Main board:P16(DC300V) Power board:P1(INVERTER)	Power harness MT set	Main board Power board	
		Spindle motor Main board:P15(UVW)	Machine motor harness set	Main board	Spindle motor
#20	"Wrong needle stop position" is displayed immediately after thread trimming action or when sewing is suspended	Transformer (14V tap) Main board:P14(INVDRV)	Transformer harness M set		Transformer
		Rotary encoder of the spindle pully Main board:P2(TIMING)	Timing harness set	Main board	Rotary encoder
		Stop position sensor board of the spindle pully Main board:P2(TIMING)	Timing harness set	Main board Stop position sensor board	
#21	"Needle case locked" or "Wrong needle case position" is displayed in thread color changing action	Potentiometer Head board:P7(INDEX)	Head sensor harness set	Head board	Potentiometer
		Index pulse motor Main board:P21(I-MOTOR)	INDEX motor harness set	Main board	Index pulse motor
		Main board:P24(POWER1) Power board:P2(MAIN)	Contorl panel board	Power board	Power board fuse:F3
#22	Stitching pattern is heavily out of shape			Main board	
		Rotary encoder of the spindle pully Main board:P2(TIMING)	Timing harness set	Main board	Secure the rotary encoder looseness
		Main board:P19(POWER2) Power board:P2(MAIN)	Contorl panel board	Power board	Power board fuse:F2
#23	Thread breakage sensor fails to work properly	Thread breakage sensor board of the head Head board:P2(UPBRK)	Regulator harness set	Head board Thread breakage sensor board	

10-5. Troubleshooting flowchart in data entry operation

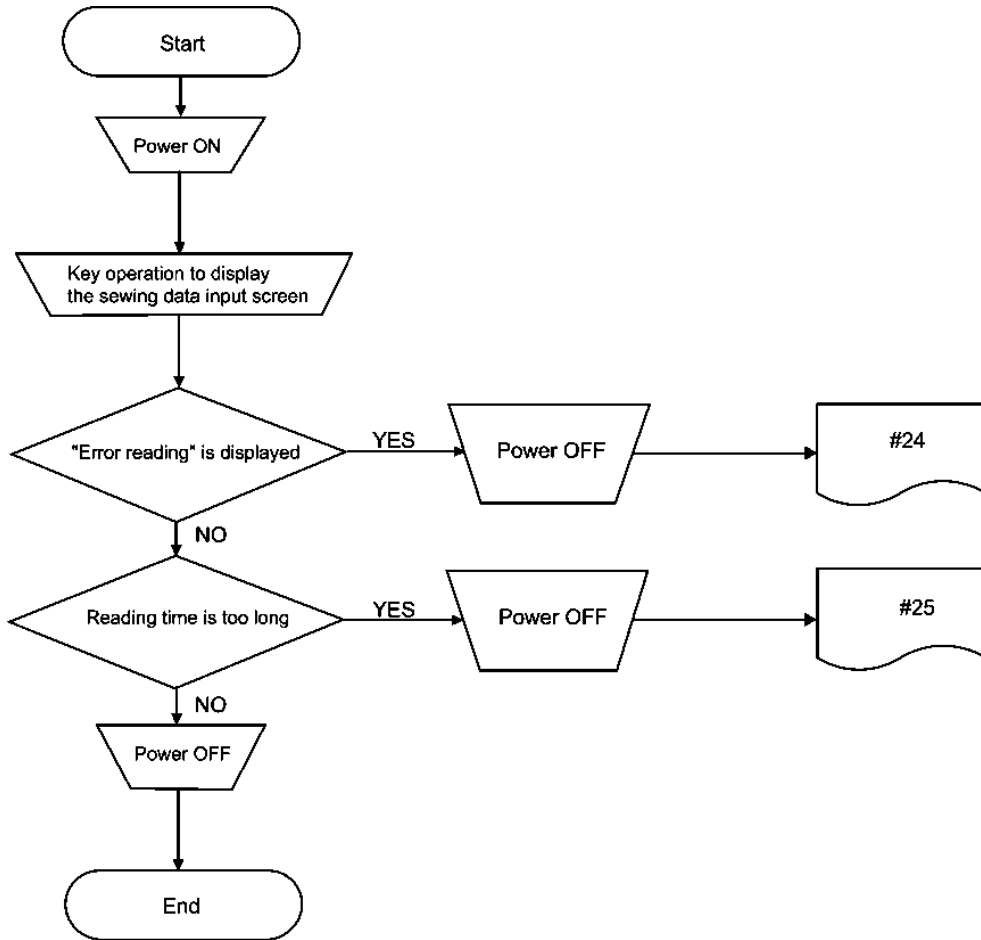

Check item	Symptom	Check parts			Other parts
		Connector check	Energized harness	Check board	
#24	"Error reading" is displayed	Control panel board:P4(FDD-P) Floppy drive 34-pin	Panel harness set	Control panel board	Floppy drive
		Control panel board:P3(FDD) Floppy drive 34-pin	FDD power harness set	Control panel board	Floppy drive
					Floppy drive fixing is
					Worn-out floppy disk
#25	Reading time is too long				Floppy drive
					Floppy drive fixing is
					Worn-out floppy disk

10-6. Troubleshooting flowchart of control panel display

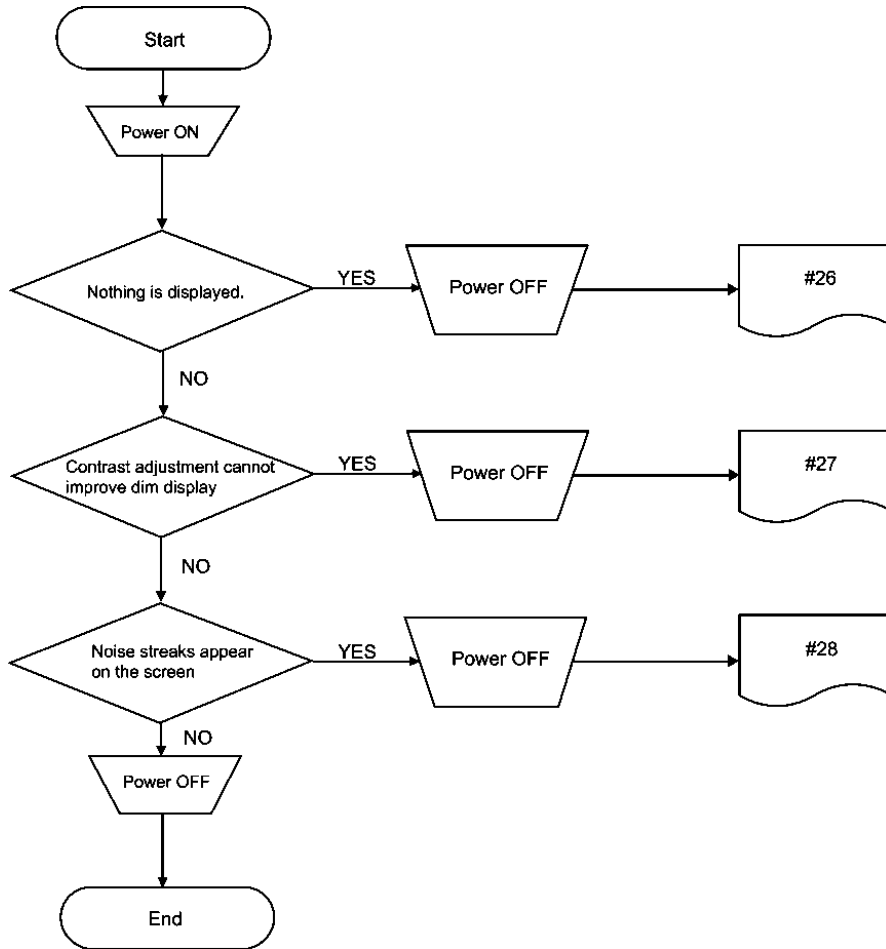

Check item	Symptom	Check parts			Other parts
		Connector check	Energized harness	Check board	
#26	Nothing is displayed.	Main board:P12(RS232C) Control panel board:P11(RS232C)	Panel harness set	Control panel board	
		Control panel board:P11(RS232C) Switching power connector in the control box Power board:P5(FDD-P)	Power harness SP set	Power board	
		Control panel board:P2(LCD) Liquid crystal display		Control panel board	Liquid crystal display(LCD)
#27	Contrast adjustment cannot improve dim display	Control panel board:P5(CFL ON/OFF) LCD inverter board	Inverter harness set	Control panel board LCD backlight board	
		Liquid crystal display LCD relay board LCD inverter board		LCD relay board LCD backlight board	Liquid crystal display(LCD)
#28	Noise streaks appear on the screen			Control panel board	Liquid crystal display(LCD)

11. Voltage check

Verify each connector voltage on the power board

11-1. Input voltage from transformer

Insert the connector into the each board and then carry out voltage measurements between specified pins from the top of the connector.

Connector number	Pin number	Signal	Normal voltage when the power is on	Symptoms by voltage anomalies (no voltage or down)
P7(AC220)	1	AC220	1-3=Approx. AC220V	(1) Main shaft does not turn. It is knocking. (2) Wrong stop position occurs frequently.
	2			
	3	AC220		
P3(TRANS)	1	AC9	1-2=Approx. AC9V	(1) The sewing machine does not run (No display on the screen).
	2	COM		
	3	AC18	3-2=Approx. AC18V	(1) The wind thread motor does not run correctly. (2) The fan does not run correctly. (3) Power failure occurs
	4	AC45	4,5-6,7=Approx. AC45V	(1) The solenoid does not operate correctly. (2) X, Y pulse motor does not run correctly. (3) Color change pulse motor does not run correctly.
	5			
	6	AC45		
7				

11-2. Output voltage to each board

Remove the connector from the board and then carry out voltage measurements between specified pins from the top of the connector.

Connector number	Pin number	Signal	Normal voltage when the power is on	Symptoms by voltage anomalies (no voltage or down)
P1(INVERTER)	1	0V	2-1=Approx. DC300V	(1) Main shaft does not turn. It is knocking.
	2	+300V		(2) Wrong stop position occurs frequently.
P2(MAIN)	1	+60V	1,2-3,4=Approx. DC60V	(1) The solenoid does not operate correctly.
	2			(2) X,Y pulse motor does not run correctly.
	3	0V		(3) Color change pulse motor does not run correctly.
	4			
	5	+24V	5-6=Approx. DC23V	
	6	0V		
	7	+5V	7-8=DC4 . 90V - 5. 10V	
	8	0V		
P4(TMOTOR)	1	+24V	1-4=Approx. DC23V	(1) The wind thread motor does not run correctly.
	2			
	3			
	4	0V		
P5(FDD-P)	1	+5V	1-3=DC4 . 90V - 5. 10V	(1) The sewing machine does not run (No display on the screen).
	2			
	3	0V		
P6(HEAD)	1	+60V	1,2-3,4=Approx. DC60V	(1) The solenoid does not operate correctly.
	2			
	3	0V		
	4			
	5	+24V	5-6=Approx. DC23V	Not used
	6	0V		
	7	0V	8-7=DC4 . 90V - 5. 10V	(1) The sewing machine does not run (No display on the screen).
	8	+5V		

11-3. Tap voltages on the transformer

11-3-1. Tap voltage layout on the terminal block

0.1A 14V	0V	0.1A 14V	0V	0.1A 14V	0V	0.1A 14V	0V	6A 45V	0V
(16)	(15)	(14)	(13)	(12)	(11)	(10)	(9)	(8)(8)	(7)(7)
		(17)			(3)		(6)(6)	(5)	(4)(4)
240V	230V	1.5A 220V	120V	0.2A 100V	0V		2A 18V	4A 9V	0V

11-3-2. Voltage values

Power on the machine and then carry out voltage measurements between specified taps on the terminal block of transformer.

Tap number	Normal voltage when the power is on	Symptoms by voltage anomalies (no voltage or down)
(16)-(15) (14)-(13) (12)-(11) (10)-(9)	Approx. AC14V	1. Main shaft does not turn. It is knocking. 2. Wrong stop position occurs frequently.
(8)-(7)	Approx. AC45V	1. The solenoid does not operate correctly. 2. X, Y pulse motor does not run correctly. 3. Color change pulse motor does not run correctly.
(17)-(3)	Approx. AC220V	1. Main shaft does not turn. It is knocking. 2. Wrong stop position occurs frequently.
(5)-(4)	Approx. AC9V	1. The sewing machine does not run (No display on the screen).
(6)-(4)	Approx. AC18V	1. The wind thread motor does not run correctly. 2. The fan does not run correctly. 3. Power failure occurs

12. Trouble shooting

Mechanical Section

BES-116AC

	Problem	Check Point
Check these points once again	- Thread breakage	<ul style="list-style-type: none"> - Is the machine properly threaded? - Is thread tension too high? - Is the rotary hook assembly clogged? - Is there thread in the bobbin? - Is the needle bent? - Is there a rough edge or flaw on the needle plate, rotary hook, or bobbin case that might cut the thread? - Is the needle installed correctly (direction, angle, etc.) - Is the presser foot in contact with the material? - Are the thread thickness and needle size correct? - Is a thread with right-hand twist being used? (If such a thread is used, replace with a thread with left-hand twist.) - Is there any adhesive on the needle? - Is the material tension too weak? - Is there too much play between the outer rotary hook and inner rotary hook? - Does the outer rotary hook turn smoothly? - Is the clearance between the rotary hook stopper and the rotary hook adjusted correctly? - Does the thread come out from the bobbin case smoothly?
	- Needle (presser foot) interference with embroidery hoop	<ul style="list-style-type: none"> - Is the embroidery hoop too small? - Check the size and needle start position in the sewing data.
	- Needle breakage	<ul style="list-style-type: none"> - Is the needle attached correctly (direction, height, etc.)? - Is the needle bent? - Is the rotary hook attached correctly? - Is the timing set correctly? - Is there any backlash with the needle bar case (back/forth and right/left)? - Is the rotary hook stopper correctly attached to stop the rotary hook? - Is the needle size correct and the tip sharp? - Does the thread pass through the hole center of the presser foot?
	- Not embroidered properly	<ul style="list-style-type: none"> - Is the material edge caught in the machine? (Are embroidery hoop and other related parts operating correctly?) - Is the material stretched properly? - Is thread tension proper? - Does the lower thread come out smoothly?

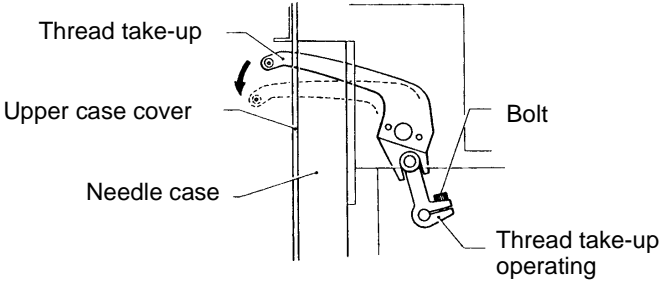
	Problem	Check Point
Check these points once again	- Machine operation abnormal	<ul style="list-style-type: none"> - Is any set screw of the rotary encoder loosened? - Is any set screw of the machine pulley loosened? - Is any set screw of the machine motor pulley loosened? - Is embroidery data normal? - Is the XY carriage wire loosened? - Is the XY carriage wire damaged? - Are any set screws for the XY pulley loosened? - Are any set screws or the coupling of the XY pulse motor loosened?
	- Upper shaft locks at a certain point in one cycle	<ul style="list-style-type: none"> - Is the thread take-up stopped due to interference with the upper case cover? <p>[Adjustment]</p>  <p style="text-align: right;"><i>H0238</i></p> <p>Loosen the hexagon socket head cap screw of the thread take-up operating lever and adjust the take-up movable range. Tighten it securely afterwards.</p> <ul style="list-style-type: none"> - Are the needle bar clamp and the top dead center stopper positioned correctly?
	- Upper shaft pulley does not turn.	<ul style="list-style-type: none"> - Is the presser foot lifted at a retract position when the power is turned on? <p>Lower the presser foot using the lever.</p>
	- Stitches cannot be made.	<ul style="list-style-type: none"> - Is the needle attached properly? - Is the timing of the needle and rotary hook correct?

	Problem	Check Point
Check these points once again	- Thread breakage	<ul style="list-style-type: none"> - Is the machine properly threaded? - Is thread tension too high? - Is the rotary hook assembly clogged? - Is there thread in the bobbin? - Is the needle bent? - Is there a rough edge or flaw on the needle plate, rotary hook, or bobbin case that might cut the thread? - Is the needle installed correctly (direction, angle, etc.) - Is the presser foot in contact with the material? - Are the thread thickness and needle size correct? - Is a thread with right-hand twist being used? (If such a thread is used, replace with a thread with left-hand twist.) - Is there any adhesive on the needle? - Is the material tension too weak? - Is there too much play between the outer rotary hook and inner rotary hook? - Does the outer rotary hook turn smoothly? - Is the clearance between the rotary hook stopper and the rotary hook adjusted correctly? - Does the thread come out from the bobbin case smoothly?
	- Needle (presser foot) interference with embroidery hoop	<ul style="list-style-type: none"> - Is the embroidery hoop too small? - Check the size and needle start position in the sewing data.
	- Needle breakage	<ul style="list-style-type: none"> - Is the needle attached correctly (direction, height, etc.)? - Is the needle bent? - Is the rotary hook attached correctly? - Is the timing set correctly? - Is there any backlash with the needle bar case (back/forth and right/left)? - Is the rotary hook stopper correctly attached to stop the rotary hook? - Is the needle size correct and the tip sharp? - Does the thread pass through the hole center of the presser foot?
	- Not embroidered properly	<ul style="list-style-type: none"> - Is the material edge caught in the machine? (Are embroidery hoop and other related parts operating correctly?) - Is the material stretched properly? - Is thread tension proper? - Does the lower thread come out smoothly?
	- Machine operation abnormal	<ul style="list-style-type: none"> - Is any set screw of the rotary encoder loosened? - Is any set screw of the machine pulley loosened? - Is any set screw of the machine motor pulley loosened? - Is embroidery data normal? - Is the XY carriage wire loosened? - Is the XY carriage wire damaged? - Are any set screws for the XY pulley loosened? - Are any set screws for the coupling of the XY pulse motor loosened?

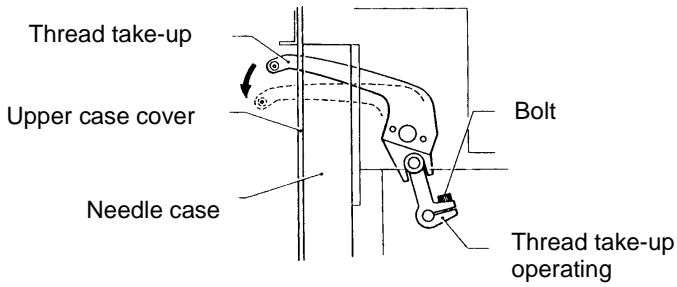

	Problem	Check Point
Check these points once again	- Upper shaft locks at a certain point in one cycle	<ul style="list-style-type: none"> - Is the thread take-up stopped due to interference with the upper case cover? <p>[Adjustment]</p>  <p style="text-align: right;"><i>H0238</i></p> <p>Loosen the hexagon socket head cap screw of the thread take-up operating lever and adjust the take-up movable range. Tighten it securely afterwards.</p> <ul style="list-style-type: none"> - Are the needle bar clamp and the top dead center stopper positioned correctly?
	- Upper shaft pulley does not turn.	<ul style="list-style-type: none"> - Is the presser foot lifted at a retract position when the power is turned on? <p>Lower the presser foot using the lever.</p>
	- Stitches cannot be mode.	<ul style="list-style-type: none"> - Is the needle attached properly? - Is the timing of the needle and rotary hook correct?

Electrical Section

BES-116AC

- (NOTE) Be sure to turn off the power of the machine and unplug the power cord before checking cable connections.
- (NOTE) When you check connection of the cables as instructed in this manual, also check connection and continuity between connectors.
- (NOTE) Carry out items described in the "Measures" section in order of appearance.
- (NOTE) Some checks and replacement works can be conducted only by repair people. In such cases, contact your dealer.

Symptom	Measures
The machine does not operate even if the power is turned on.	<ul style="list-style-type: none"> - Is the power cord of the machine plugged in? -> Plug in the power cord. - Is the connector in the control box connected? -> Connect it after checking the types and colors of the connectors. - Is fuse F1 or F5 on the power PCB in the control box blown? -> Replace the fuse with a new one. If the fuse is blown again, something is faulty. Check to see if the wiring is correct. Replace the control box with a new one.
<p>The machine does not operate even if the power is turned on.</p> <p>The message, "Release stop SW to operate!", is displayed on the panel.</p>	<ul style="list-style-type: none"> - Is the stop switch (Option) turned on? -> Reset the stop switch.
An overtravel error occurs.	<ul style="list-style-type: none"> - Is the frame within the cap frame area? -> Move the frame within the cap frame area and turn on the power. - Check to see if the signal of the X area sensor turns ON and OFF in PORT test mode. -> When the signal does not change, refer to the block diagram showing the cable connection and check to see if connection from the X cap sensor to the main PCB is proper. Replace the X cap sensor with a new one.
The needle stop position error occurs.	<ul style="list-style-type: none"> - Is the pulley manually turned and out of the stop angle? -> Turn the pulley, adjust the needle at the stop position, and reset the error. - Check the signal of the stop position sensor in the encoder test mode. -> Refer to the adjustment or cable connection block diagram and check connection from the needle position detention sensor to the main PCB. Replace the needle position detection sensor with a new one.

Symptom	Measures
X-axis or Y-axis home position detection error occurs.	<ul style="list-style-type: none"> - Was the XY carriage moving? -> If so, refer to the block diagram showing the cable connections and check to see if connection from the X and Y area sensor to the main PCB is proper. - Was the XY motor rotating? -> If so, check the XY carriage mechanism. - If the XY motor is not rotating, refer to the cable connection block diagram and check to see if connection from the XY motor to the main PCB is proper.
The thread breakage error frequently occurs although thread is not broken.	<ul style="list-style-type: none"> - Enter the needle bar case test mode by pressing  and , turn the thread breakage pulley. If the needle bar number icon is displayed reversely, lower the thread breakage sensitivity value of the machine controller. (The standard value is 0.) - Check connection from the thread breakage sensor PCB to the head PCB if the needle bar number icon is not displayed reversely. - Replace the thread breakage sensor PCB with a new one.
The main shaft motor lock error occurs.	<ul style="list-style-type: none"> - Enter the encoder signal mode and manually turn the main shaft pulley. -> If it is abnormally heavy, the main shaft mechanism is faulty. - Does the main shaft motor rotate at all when the error occurs? -> If it does not rotate at all, check fuse F1 and F5 on the power supply PCB in the control box. Refer to the block diagram showing the cable connection and check to see if connection from the main shaft motor to the main PCB is proper. Also check connection of connectors P15 and P16 of the main PCB and connectors P1 and P2 on the power PCB in the box, and connection from connector P14 of the main PCB to the 14v terminal of the power transformer. - Manually turn the main shaft pulley in the encoder signal test mode and check to see if the stop position signal and encoder signal are proper. -> If either of the signals does not change, refer to the block diagram showing the cable connections and check to see if connection from the encoder and stop position sensor to the main PCB is proper.
ERROR A8 frequently occurs.	<ul style="list-style-type: none"> - In the encoder signal test mode, manually turn the main shaft pulley and check to see that the stop position signal is correct. -> If the signal does not change, refer to the cable connection block diagram and check to see if connection from the stop position sensor to the main PCB is proper.
Main shaft rotation speed error occurs.	<ul style="list-style-type: none"> - Enter the encoder signal test mode and manually turn the main shaft pulley. -> If it is abnormally heavy, the main shaft mechanism is faulty. - Refer to the block diagram showing the cable connections and check to see if connection from the main shaft motor to the main PCB is proper. Also check the connection from connectors P14 of the main PCB to the 14v terminal of the power transformer.
Exhaust fan motor stops. Cooling fan motor stops.	<ul style="list-style-type: none"> - Refer to the block diagram showing the cable connections and check to see if connection of connector P22 and P27 of the main PCB in the control box is proper. - Check fuse F3 on the power supply PCB. -> If it is blown, replace it with a new one .If it becomes blown again, the 24v system circuit is faulty.

Symptom	Measures
ERROR E5 to ERROR FF frequently occur.	- Replace the main PCB with a new one.
All solenoids of head do not operate.	- Refer to the block diagram showing cable connections and check fuse F2 on the power supply PCB. -> If it is blown, replace it with a new one. The 60v circuit is faulty if the fuse is blown immediately after turning on the power even after replacing the fuse.
Jump solenoid does not operate.	- Check to see if connection from the jump solenoid to connector P10 of the head PCB is proper. - Check the resistance value of the jump solenoid, which does not operate with the connector section. The normal resistance value is approximately 185Ω. -> If it is faulty, replace the solenoid with a new one. In this case, the head PCB may also be faulty. Also replace the head PCB with a new one if it does not operate properly even after replacing the solenoid. - Replace the head PCB with a new one.
Picker solenoid does not operate.	- Check to see if connection from the picker solenoid to connector P8 of the head PCB is proper. - Check the resistance value of the picker solenoid, which does not operate with the connector section. The normal resistance value is approximately 426Ω. -> If it is faulty, replace the solenoid with a new one. In this case, the head PCB may also be faulty. Also replace the head PCB with a new one if it does not operate properly even after replacing the solenoid. - Replace the head PCB with a new one.
Thread trimmer solenoid does not operate.	- Check to see if connection from the thread trimmer solenoid to connector P20 of the main PCB is proper. - Check the resistance value of the thread trimmer solenoid, which does not operate with the connector section. The normal resistance value is approximately 30Ω. -> If it is faulty, replace the solenoid with a new one. In this case, the main PCB may also be faulty. Also replace the main PCB with a new one if it does not operate properly even after replacing the solenoid. - Replace the main PCB with a new one.
Presser foot solenoid does not operate.	- Check to see if connection from the presser foot solenoid to connector P20 of the main PCB is proper. - Check the resistance value of the presser foot solenoid, which does not operate with the connector section. The normal resistance value is approximately 81Ω. -> If it is faulty, replace the solenoid with a new one. In this case, the main PCB may also be faulty. Also replace the main PCB with a new one if it does not operate properly even after replacing the solenoid. - Replace the main PCB with a new one.

BES-916AC, 1216AC

- (NOTE) Be sure to turn off the power of the machine and unplug the power cord before checking cable connections.
- (NOTE) When you check connection of the cables as instructed in this manual, also check connection and continuity between connectors.
- (NOTE) Carry out items described in the "Measures" section in order of appearance.
- (NOTE) Some checks and replacement works can be conducted only by repair people. In such cases, contact your dealer.

Symptom	Measures
The machine does not operate even if the power is turned on.	<ul style="list-style-type: none"> - Is the power cord of the machine plugged in? -> Plug in the power cord. - Is the connector in the control box connected? ->Connect it after checking the types and colors of the connectors. - Is fuse F1 or F5 on the power PCB in the control box blown? -> Replace the fuse with a new one. If the fuse is blown again, something is faulty. Check to see if the wiring is correct. Replace the control box with a new one.
<p>The machine does not operate even if the power is turned on.</p> <p>The message, "Release stop SW to operate!", is displayed on the panel.</p>	<ul style="list-style-type: none"> - Is the stop switch (Option) turned on? -> Reset the stop switch.
An over travel error occurs.	<ul style="list-style-type: none"> - Is the frame within the cap frame area? -> Move the frame within the cap frame area and turn on the power. - Check to see if the signal of the X area sensor turns ON and OFF in PORT test mode. -> When the signal does not change, refer to the block diagram showing the cable connection and check to see if connection from the X cap sensor to the main PCB is proper. Replace the X cap sensor with a new one.
The needle stop position error occurs.	<ul style="list-style-type: none"> - Is the pulley manually turned and out of the stop angle? -> Turn the pulley, adjust the needle at the stop position, and reset the error. - Check the signal of the stop position sensor in the encoder test mode. -> Refer to the adjustment or cable connection block diagram and check connection from the needle position detention sensor to the main PCB. Replace the needle position detection sensor with a new one. - Are there any problems with the main shaft mechanism? (i.e. The screw of the main shaft pulley is loose.)

Symptom	Measures
The needle bar case lock error occurs.	<ul style="list-style-type: none"> - Is the INDEX motor rotating? -> If not, refer to the block diagram showing the cable connections and check to see if connection from the INDEX motor to the main PCB is proper. Check the resistance values of pins 1 and 2 and pins 3 and 4 at the connector section of the INDEX motor. The normal resistance value is approximately 10Ω. -> If it is not normal, replace the INDEX motor with a new one. Also replace the main PCB with a new one. - Manually turn the color change pulley. -> If it is abnormally heavy, adjust the color change mechanism and the needle bar case. - Start the machine after invalidating its initial setting and enter the needle bar case test mode. Do figures on the panel change when the color change pulley is manually turned? -> If not, check to see if connection from the needle bar position sensor to connector P7 of the head PCB is proper. - Replace the needle bar position sensor (potentiometer) with a new one. - Replace the head PCB with a new one.
X-axis or Y-axis home position detection error occurs.	<ul style="list-style-type: none"> - Was the XY carriage moving? -> If so, refer to the block diagram showing the cable connections and check to see if connection from the X and Y area sensor to the main PCB is proper. - Was the XY motor rotating? -> If so, check the XY carriage mechanism. - If the XY motor is not rotating, refer to the cable connection block diagram and check to see if connection from the XY motor to the main PCB is proper.
The thread breakage error frequently occurs although thread is not broken.	<ul style="list-style-type: none"> - Enter the needle bar case test mode and turn the thread breakage sensor pulley while switching the needle bar from number 1 in ascending order. -> If there is no problem, lower the thread breakage sensitivity value of the machine controller. (The standard value is 0.) - Check connection from the thread breakage sensor PCB to the head PCB if the number does not blink. - Replace the thread breakage sensor PCB with a new one.

Symptom	Measures
The main shaft motor lock error occurs.	<ul style="list-style-type: none"> - Enter the encoder signal mode and manually turn the main shaft pulley. -> If it is abnormally heavy, the main shaft mechanism is faulty. - Does the main shaft motor rotate at all when the error occurs? -> If it does not rotate at all, check fuses F1 and F5 on the power supply PCB in the control box. Refer to the block diagram showing the cable connections and check to see if connection from the main shaft motor to the main PCB is proper. Also check connection of connectors P15 and P16 of the main PCB and connectors P1 and P2 on the power PCB in the box, and connection from connector P14 of the main PCB to the 14v terminal of the power transformer. - Manually turn the main shaft pulley in the encoder signal test mode and check to see if the stop position signal and encoder signal are proper. -> If either of the signals does not change, refer to the block diagram showing the cable connections and check to see if connection from the encoder and stop position sensor to the main PCB is proper.
ERROR A8 frequently occurs.	<ul style="list-style-type: none"> - In the encoder signal test mode, manually turn the main shaft pulley and check to see that the stop position signal is correct. -> If the signal does not change, refer to the cable connection block diagram and check to see if connection from the stop position sensor to the main PCB is proper.
Wiper out error occurs.	<ul style="list-style-type: none"> - Does the wiper remain projected? -> If the wiper is tangled with a thread, remove it. If the wiper does not return smoothly, adjust it. - Enter the solenoid test mode and operate the wiper solenoid. Check the icon on the panel. -> If the panel is not changed, check to see if connection from the wiper sensor to the head PCB is proper. Replace the wiper sensor with a new one. Replace the head PCB with a new one.
Main shaft rotation speed error occurs.	<ul style="list-style-type: none"> - Enter the encoder signal test mode and manually turn the main shaft pulley. -> If it is abnormally heavy, the main shaft mechanism is faulty. - Refer to the block diagram showing the cable connections and check to see if connection from the main shaft motor to the main PCB is proper. Also check the connection from connectors P14 of the main PCB to the 14v terminal of the power transformer.
Exhaust fan motor stops.	<ul style="list-style-type: none"> - Refer to the block diagram showing the cable connections and check to see if connection of connector P22 of the main PCB in the control box is proper. - Check fuse F3 on the power supply PCB. -> If it is blown, replace it with a new one .If it becomes blown again, the 24v system circuit is faulty.
ERROR E5 to ERROR FF frequently occur.	<ul style="list-style-type: none"> - Replace the main PCB with a new one.
All solenoids of head do not operate.	<ul style="list-style-type: none"> - Refer to the block diagram showing cable connections and check fuse F2 on the power supply PCB. -> If it is blown, replace it with a new one. The 60v circuit is faulty if the fuse is blown immediately after turning on the power even after replacing the fuse.

Symptom	Measures
Jump solenoid does not operate.	<ul style="list-style-type: none"> - Check to see if connection from the jump solenoid to connector P10 of the head PCB is proper. - Check the resistance value of the jump solenoid, which does not operate with the connector section. The normal resistance value is approximately 185Ω. -> If it is faulty, replace the solenoid with a new one. In this case, the head PCB may also be faulty. Also replace the head PCB with a new one if it does not operate properly even after replacing the solenoid. - Replace the head PCB with a new one.
Wiper solenoid does not operate.	<ul style="list-style-type: none"> - Check to see if connection from the wiper solenoid to connector P11 of the head PCB is proper. - Check the resistance value of the wiper solenoid, which does not operate with the connector section. The normal resistance value is approximately 23Ω. -> If it is faulty, replace the solenoid with a new one. In this case, the head PCB may also be faulty. Also replace the head PCB with a new one if it does not operate properly even after replacing the solenoid. - Replace the head PCB with a new one.
Picker solenoid does not operate.	<ul style="list-style-type: none"> - Check to see if connection from the picker solenoid to connector P8 of the head PCB is proper. - Check the resistance value of the picker solenoid, which does not operate with the connector section. The normal resistance value is approximately 426Ω. -> If it is faulty, replace the solenoid with a new one. In this case, the head PCB may also be faulty. Also replace the head PCB with a new one if it does not operate properly even after replacing the solenoid. - Replace the head PCB with a new one.
Thread trimmer solenoid does not operate.	<ul style="list-style-type: none"> - Check to see if connection from the thread trimmer solenoid to connector P20 of the main PCB is proper. - Check the resistance value of the thread trimmer solenoid, which does not operate with the connector section. The normal resistance value is approximately 30Ω. -> If it is faulty, replace the solenoid with a new one. In this case, the main PCB may also be faulty. Also replace the main PCB with a new one if it does not operate properly even after replacing the solenoid. - Replace the main PCB with a new one.
Presser foot solenoid does not operate.	<ul style="list-style-type: none"> - Check to see if connection from the presser foot solenoid to connector P20 of the main PCB is proper. - Check the resistance value of the presser foot solenoid, which does not operate with the connector section. The normal resistance value is approximately 81Ω. -> If it is faulty, replace the solenoid with a new one. In this case, the main PCB may also be faulty. Also replace the main PCB with a new one if it does not operate properly even after replacing the solenoid. - Replace the main PCB with a new one.

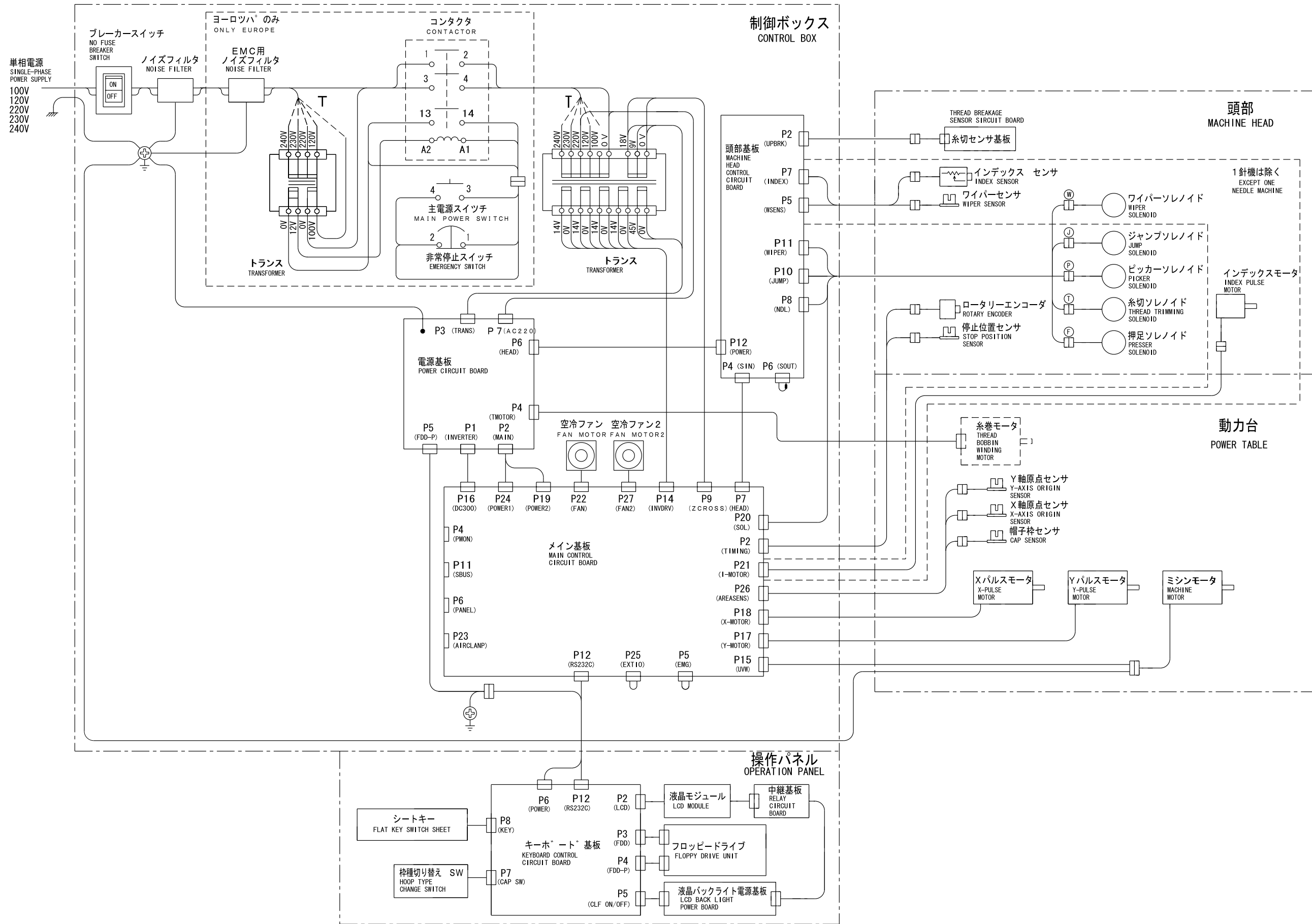

brother[®]

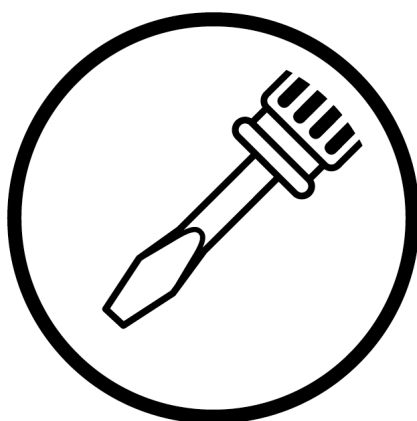

SERVICE MANUAL

BROTHER INDUSTRIES, LTD.

15-1, Naeshiro-cho, Mizuho-ku, Nagoya 467-8561, Japan. Phone: 81-52-824-2177

Printed in Japan

155-116, 916, C16
I1050809F
2001.08.F (1)