

# DT3-B291

Cylinder Bed Needle Feed  
Double Chain Stitcher



## Specifications

DT3 - B291 - **060** -

No. of needles & Needle gauge	
7	Twin needle, 31.8 mm (1 1/4)
8	Twin needle, 34.9 mm (1 3/8)
A	4 needle, 6.4-25.4-6.4 (1/4 - 1 1/4)

Sub-class	
060	For sewing waist bands (heavy materials)

Sub-class	-7	-8	-A
Use	For sewing waist bands jeans (for medium to heavy materials)		
No. of needles	2		4
Needle size	Schmetz Nm110 – Nm140 (#18 - #22)		
Needle gauge	Twin needle 31.8 mm (1 1/4)	Twin needle 34.9 mm (1 3/8)	4 needle 6.4 - 25.4 - 6.4 (1/4 - 1 1/4)
No. of threads	4		8
Max. stitch length	4.5 mm		
Presser foot lift height	10 mm		
Max. sewing speed	4,500 rpm		

## Optional parts

\*The optional parts listed below can all be installed to the sewing machine at any time after purchase.

\*The optional parts A to C listed below are pneumatic-type parts. Electronic control is not required for these parts, so that they can be used with clutch motors.

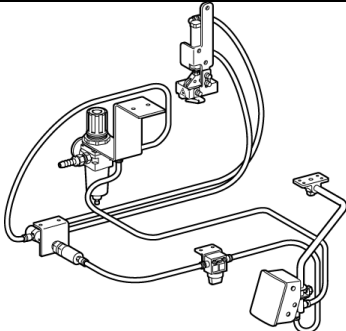
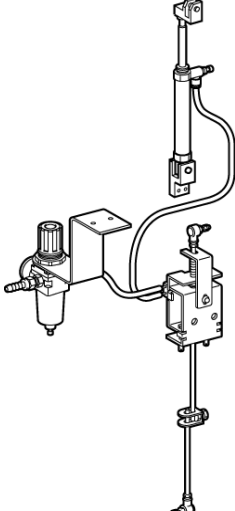
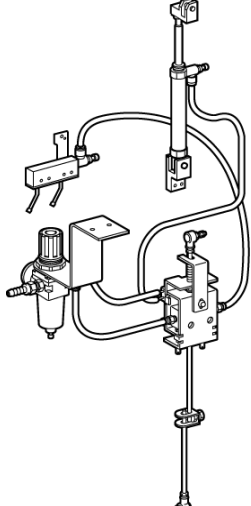
	Part name	Part code	Applicable subclass
A		S51748-001	060-7 060-8 060-A
B		S51721-001	060-7 060-8 060-A
C		S51735-001	060-7 060-8

## Optional parts

### Synchronizer

This lets you set the preferred needle stop position. When the sewing machine stops, The needle stops at the position that has been set.

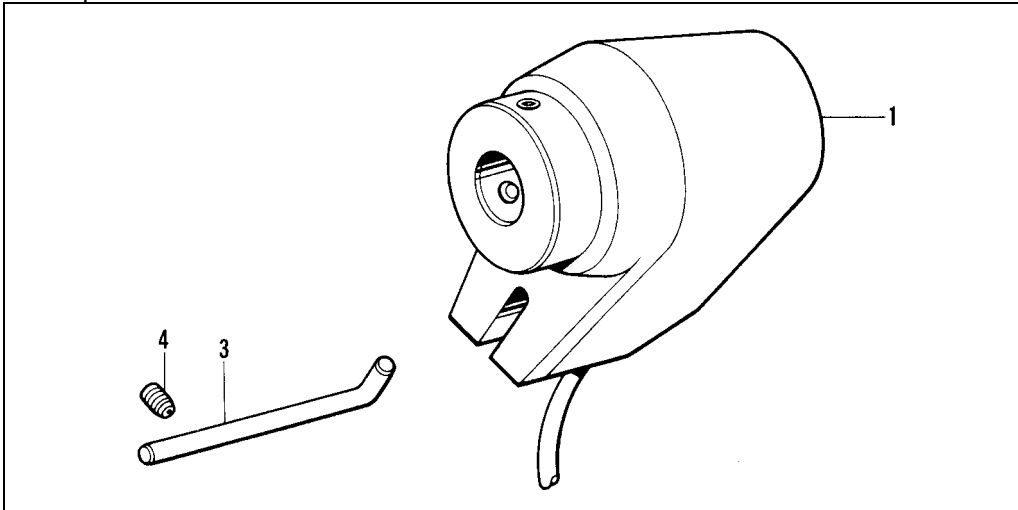

Ref. No.	Part name	Part code	Q'ty
1	Synchronizer #17-2	J80347-001	1
3	Synchronizer guide	S28963-001	1
4	Set screw, socket (CP) SM4.37	014680-622	1

\* Applicable subclasses are 060-7, 060-8, and 060-A.

\* When using the synchronizer, use the motor and V belt listed below.

\* Ref. No.3 and No.4 are packed together with the accessories for the machine.

### Motor

MD601R (Single phase)	The motor operating specifications must conform to these given below. Consult the place of purchase for details. <ul style="list-style-type: none"> <li>• Direction of rotation ..... Forward</li> <li>• Sewing speed ..... 4,500 rpm</li> </ul>
MD611R (3-phase)	

### V-belt

Pulley O. D. (mm)	90	105 (Standard)
Belt size (inches)	M38	M39

### Lapper

\* Since lapper and lapper set bracket are not optional parts, please order.

## When converting from 2-needle specification to 4-needle specification

If a customer who has already purchased 2-needle specification would like to change it to 4-needle specification, order the parts listed below.

### Thread tension

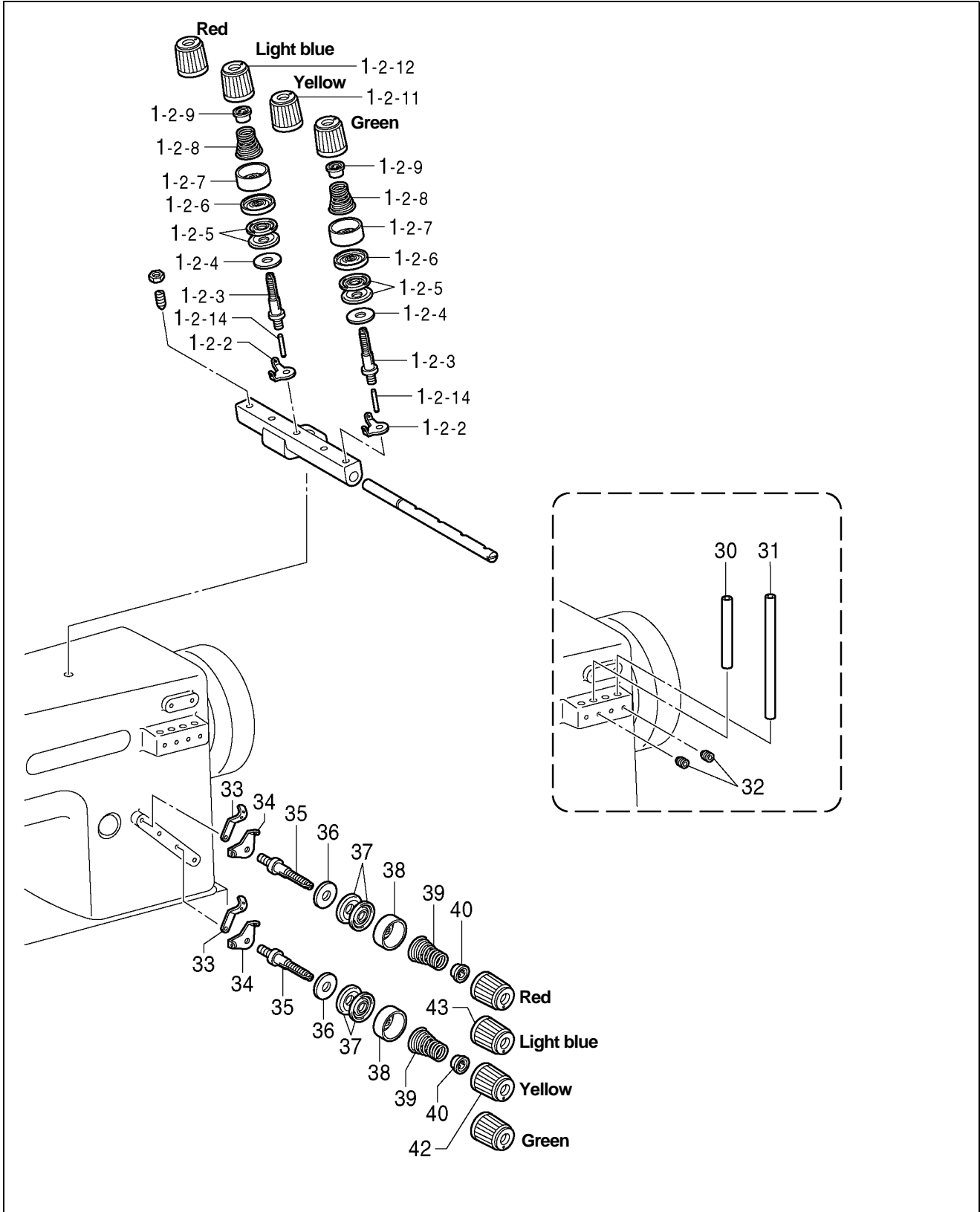

Ref.No.	Parts code	Q'ty	Name of parts
1-2-2	S38737-001	2	Thread guide
1-2-3	145440-001	2	Tension stud
1-2-4	110832-009	2	Felt, ;T-disc
1-2-5	145446-001	4	Disc, tension
1-2-6	159805-001	2	Disc presser, ;tension
1-2-7	144103-009	2	Disc presser, ;tension
1-2-8	148851-001	2	Tension spring
1-2-9	S30564-000	2	Washer
1-2-11	S30565-004	1	Tension nut, yellow
1-2-12	S30565-001	1	Tension nut, light blue
1-2-14	105231-000	2	Tension release pin
30	150644-009	1	Thread guide pipe, S
31	150645-009	1	Thread guide pipe, L
32	014680-432	2	Set screw, socket (CP) SM4.37
33	S08963-001	2	Thread guide, ;T-bracket
34	110813-001	2	Thread guide, ;needle
35	159574-101	2	Tension stud
36	110832-009	2	Felt, ;T-disc
37	145446-001	4	Disc, tension
38	144103-009	2	Disc presser, ;tension
39	144110-001	2	Tension adjusting spring
40	S30564-000	2	Washer
42	S30565-004	1	Tension nut, yellow
43	S30565-001	1	Tension nut, light blue

# When converting from 2-needle specification to 4-needle specification

## Cotton stand

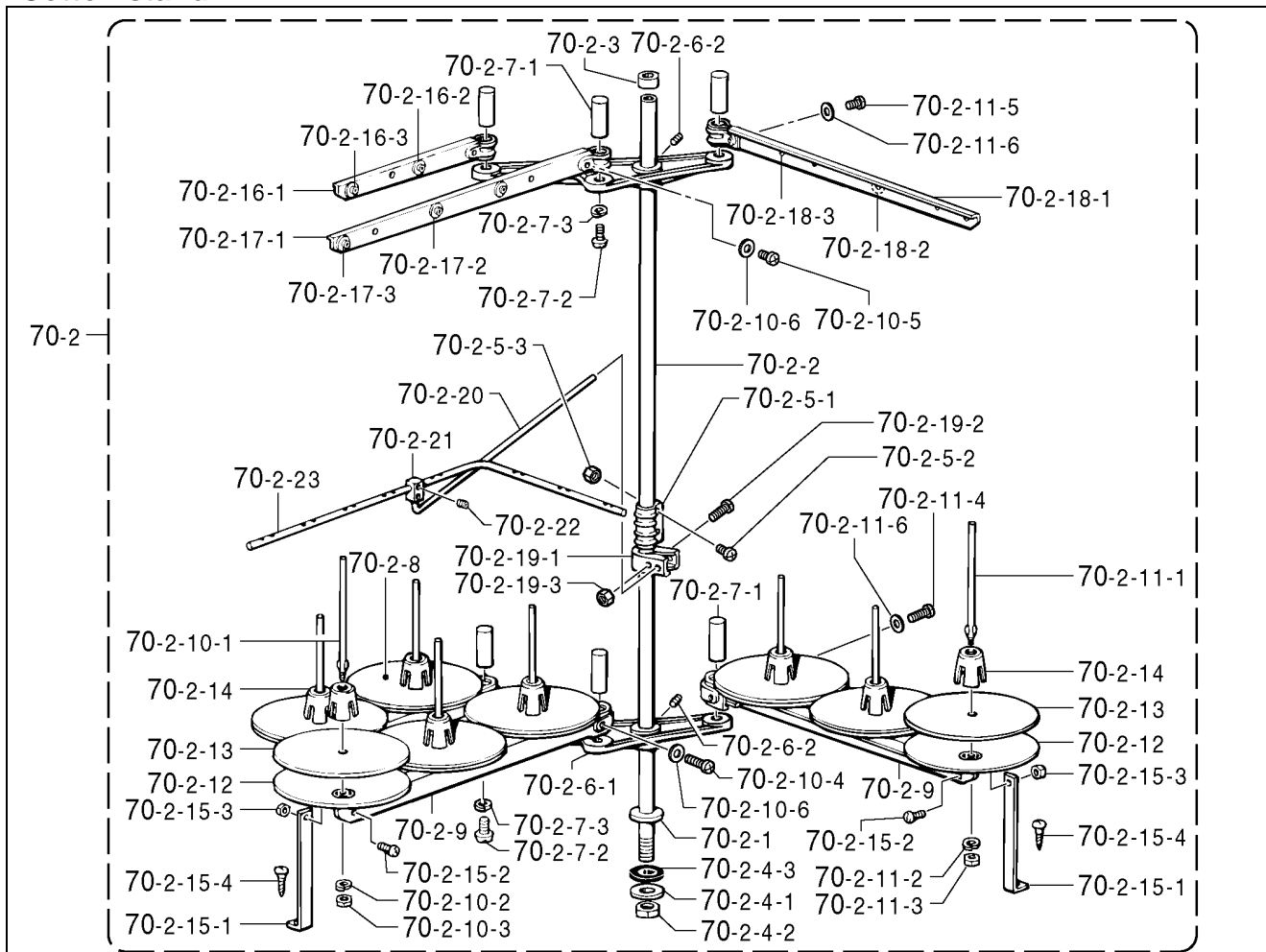

Ref.No.	Parts code	Q'ty	Name of parts
70-2	S12810-109	1	Cotton stand assy, 8th
70-2-1	156112-003	1	Column pipe, D
70-2-2	150172-003	1	Column pipe
70-2-3	150174-000	1	Column cap
70-2-4	S13794-001	1	Pipe & screw set, A
70-2-4-1	150206-000	1	Washer, plain 16
70-2-4-2	S38648-001	1	Nut, U5/8-28
70-2-4-3	S01005-000	1	Rubber washer
70-2-5	150106-003	1	Column joint assy
70-2-5-1	150173-003	1	Column joint
70-2-5-2	062501-406	2	Screw, pan M5×14
70-2-5-3	021500-106	2	Nut, 1 M5
70-2-6	S13173-009	2	Holder support bracket assy
70-2-6-1	S13174-109	2	Holder support bracket
70-2-6-2	014060-632	2	Set screw, socket (CP) M6×6
70-2-7	S13175-001	6	Holder shaft assy, S
70-2-7-1	S13176-001	6	Holder shaft, S
70-2-7-2	062502-002	6	Screw, pan M5×20
70-2-7-3	028050-242	6	Washer, spring 2-5
70-2-8	S02778-002	1	Spool holder, 2
70-2-9	S02779-009	2	Spool holder, 3

Ref.No.	Parts code	Q'ty	Name of parts
70-2-10	S02780-001	1	Spool screw, set, 2
70-2-10-1	150179-002	2	Spool shaft, B
70-2-10-2	028050-246	2	Washer, spring 2-5
70-2-10-3	021500-106	4	Nut, 1 M5
70-2-10-4	062503-506	1	Screw, pan M5×35
70-2-10-5	062501-406	1	Screw, pan M5×14
70-2-10-6	026050-136	2	Washer, plain S5
70-2-11	S02782-001	2	Spool & screw set, 3
70-2-11-1	150179-002	3	Spool shaft, B
70-2-11-2	028050-246	3	Washer, spring 2-5
70-2-11-3	021500-106	5	Nut, 1 M5
70-2-11-4	062503-506	1	Screw, pan M5×35
70-2-11-5	062501-406	1	Screw, pan M5×14
70-2-11-6	026050-136	2	Washer, plain S5
70-2-12	S51283-001	8	Spool stand base
70-2-13	150182-000	8	Spool mat
70-2-14	S51282-001	8	Spool cushion
70-2-15	S02784-009	2	Holder support set, A
70-2-15-1	150188-009	2	Spool holder support, A
70-2-15-2	062501-006	2	Screw, pan M5×10
70-2-15-3	021500-106	2	Nut, 1M5
70-2-15-4	031452-206	2	Wood screw, round M4.5×22
70-2-16	S02786-002	1	Thread hanger assy, 2
70-2-16-1	S02787-002	1	Thread hanger, 2
70-2-16-2	150183-000	2	Thread hanger base
70-2-16-3	142990-001	2	Thread bush
70-2-17	S02788-009	1	Thread hanger assy, 3
70-2-17-1	S02789-009	1	Thread hanger, 3
70-2-17-2	150183-000	5	Thread hanger base
70-2-17-3	142990-001	3	Thread bush
70-2-18	S13666-009	1	Thread hanger assy 3-5
70-2-18-1	S02789-009	1	Thread hanger, 3
70-2-18-2	150183-000	5	Thread hanger base
70-2-18-3	142990-001	5	Thread bush
70-2-19	150145-009	1	Thread guide holder assy
70-2-19-1	150185-009	1	Thread guide holder
70-2-19-2	062503-506	1	Screw, pan M5×35
70-2-19-3	021500-106	1	Nut, 1M5
70-2-20	S04109-001	1	Support bar,;TR-guide
70-2-21	138843-001	1	Joint
70-2-22	014060-632	2	Set screw, socket (CP) M6×6
70-2-23	S13172-001	1	Thread guide, 8

## When converting from 2-needle specification to 4-needle specification

### Gauge parts for 4-needle specification

Needle gauge: 6.4 - 25.4 - 6.4 mm

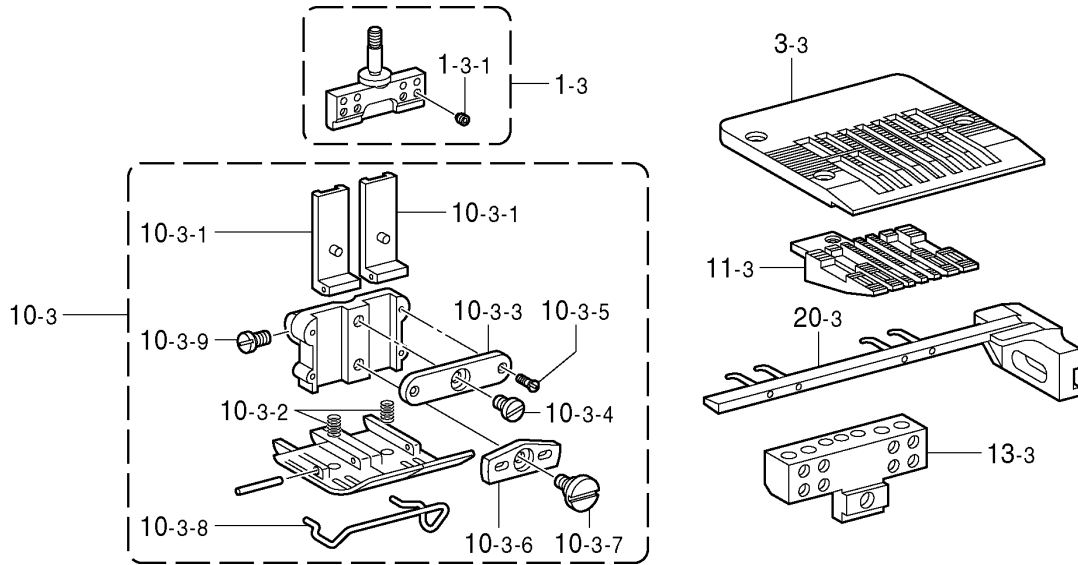



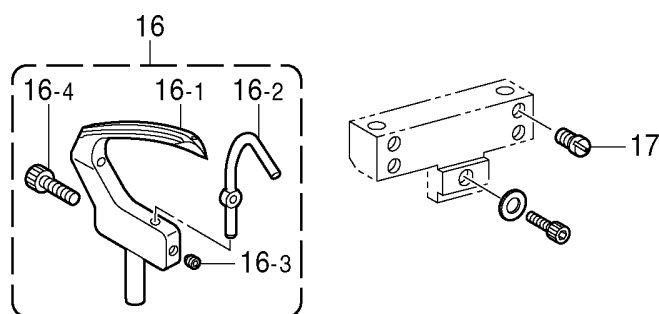

Ref.No.	Parts code	Q'ty	Name of parts
1-3	S55853-001	1	Needle clamp assy, 1/4-1-1/4
1-3-1	146427-001	4	Set screw, socket (CP) SM3.18
3-3	S55855-001	1	Needle plate, 1/4-1-1/4; four
10-3	S55856-001	1	Presser foot assy, 1/4-1-1/4
10-3-1	S51598-001	1	Holder bracket, ;P-foot
10-3-2	S51603-001	2	Spring, compression
10-3-3	S51605-001	1	Holder plate
10-3-4	S51626-001	1	Screw, SM4.37-40×3.8
10-3-5	S51625-001	2	Screw, flat SM2.38-56×6
10-3-6	S51606-001	1	Holder plate, ;movable
10-3-7	S51607-001	1	Shoulder screw, SM4.76
10-3-8	S51608-101	1	Finger guard
10-3-9	S51627-001	1	Screw, M5×7.1
11-3	S55859-001	1	Feed dog, 1/4-1-1/4; four
13-3	S55860-001	1	Looper holder, 1/4-1-1/4; four
20-3	S55861-101	1	Retainer assy, 1/4-1-1/4; four



Ref.No.	Parts code	Q'ty	Name of parts
16	S51616-001	2	Looper assy
16-1	S51617-001	2	Looper
16-2	S51618-001	2	Needle guard,; looper
16-3	014300-322	2	Set screw, socket (CP) M3×3
16-4	018301-222	2	Bolt, socket M3×12
17	100366-002	4	Set screw, (FT) SM4.37×5

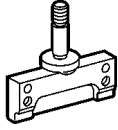
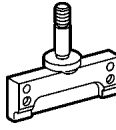
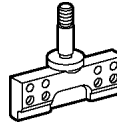
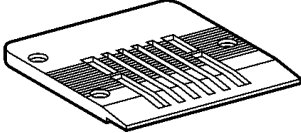
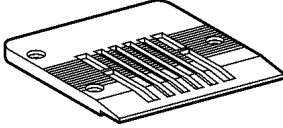
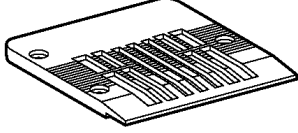
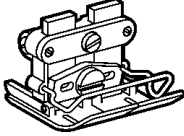
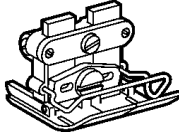
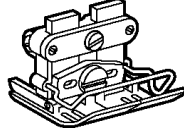

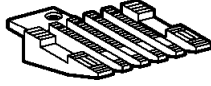
## Gauge parts list

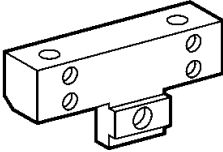
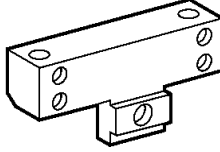
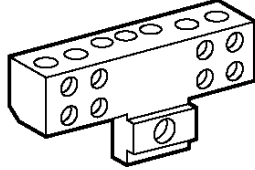
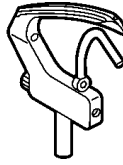
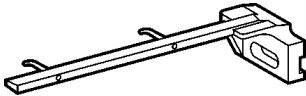
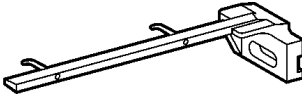
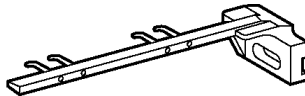
Specifications	060-7	060-8	060-A
Label	S28933-015	S28933-016	
Application	For sewing waist bands jeans (for medium to heavy materials)		
No. of needles	2	2	4
Needle gauge	31.8 mm	34.9 mm	6.4-25.4-6.4 mm
Needle clamp assy	 S51592-001	 S51590-001	 S55853-001
Needle plate	 S50596-101	 S51595-101	 S55855-001
Presser foot assy	 S51609-101	 S51597-101	 S55856001
Feed dog	 S51613-101	 S51612-101	 S55859-001
Looper holder	 S51615-001	 S51614-001	 S55860-001
Looper	 S51616-001		
Retainer	 S51622-001	 S51619-001	 S55861-101