

brother

SERVICE MANUAL

FOR

B706

B707

B714

B716

B747

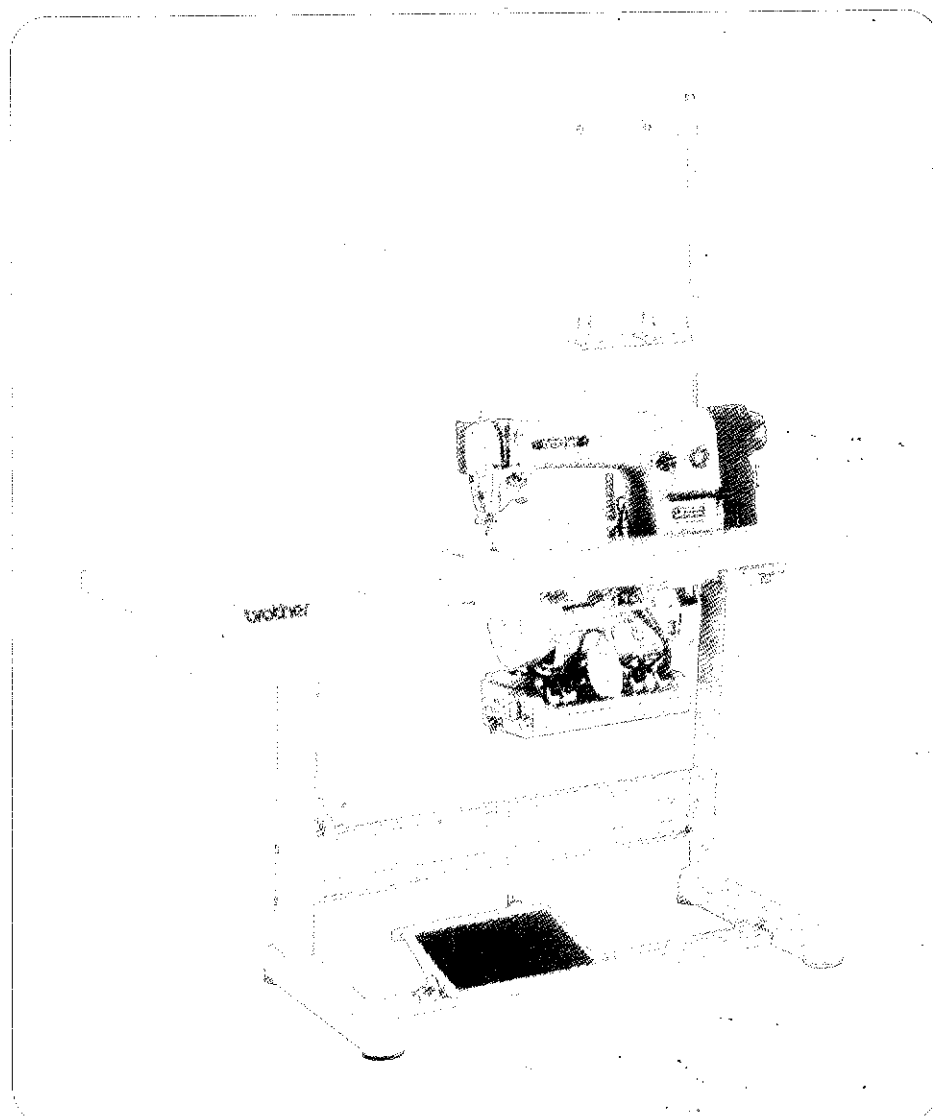

BROTHER INDUSTRIES, LTD.

NAGOYA, JAPAN

CONTENTS

MECHANISM	1	ASSEMBLY	14
1 Upper shaft and needle bar mechanism	1	1 Needle bar	14
2 Lower shaft and rotary hook mechanism	1	2 Feed mechanism (B706/B707)	15
3 Feed mechanism (B714/ B716/ B747)	2	2 Feed mechanism (B714/ B716/ B747)	16
3 Feed mechanism (B706/ B707)	3	3 Thread trimmer	17
4 Lubrication mechanism	4	4 Rotary hook	18
5 Thread trimmer mechanism	6	5 Presser mechanism	19
6 Thread tension release lever (B707/ B716/ B747)	9	6 Cover	19
7 Thread wiper mechanism	9	ADJUSTMENTS	20
8 Quick-back mechanism	9	1 Needle and rotary hook timing adjustments	20
9 Automatic presser lifter mechanism	9	2 Feed dog height adjustment	21
DISASSEMBLY	10	3 Feed timing adjustment	21
1 Cover	10	4 Presser height adjustment	21
2 Presser	10	5 Synchronizer adjustment	22
3 Rotary hook	11	6 Thread trimmer adjustment	23
4 Thread trimmer	11	7 Tension release lever adjustment	24
5 Feed mechanism (B706/ B707)	12	8 Thread wiper adjustment	24
5 Feed mechanism (B714/ B716/ B747)	13	9 Automatic presser foot lifter adjustment (—900; electromagnetic type)	24
6 Needle bar mechanism	13	TROUBLESHOOTING GUIDE ...	25

MECHANISM

1 Upper shaft and needle bar mechanism

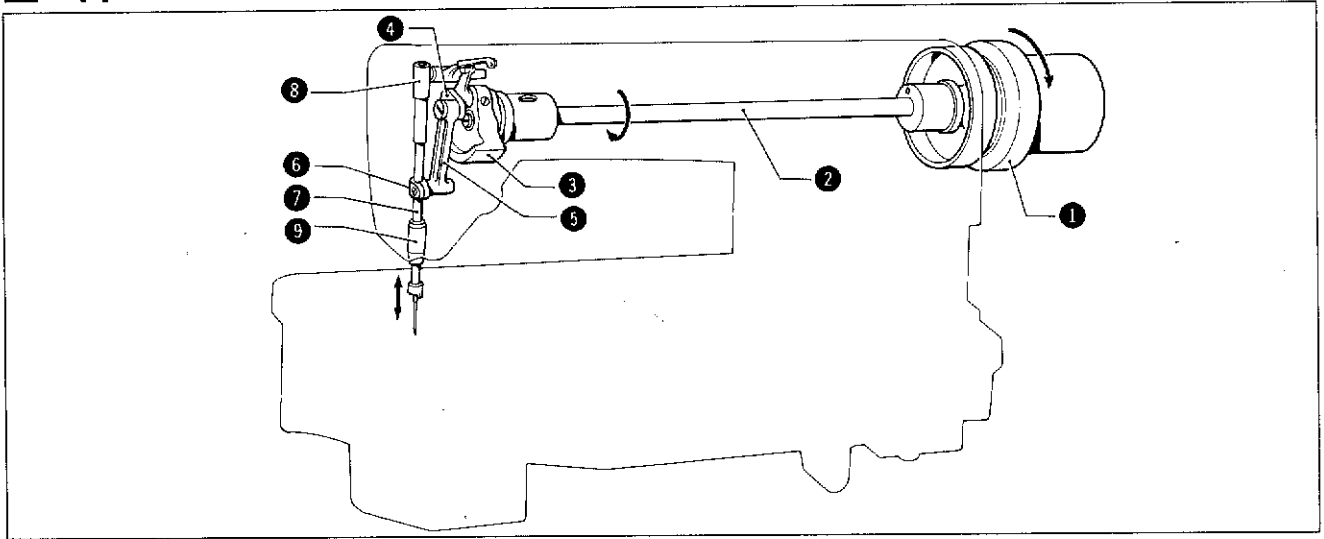

1. When the pulley ① turns in the direction indicated by the arrow, the movement is transmitted to the upper shaft ② and causes the counter weight ③ to turn.
2. The movement is transmitted to the needle bar connecting rod ⑤ via the needle bar crank ④ connected to the counter weight.
3. The needle bar ⑦ connected to the needle bar clamp ⑥ is moved up and down.
4. The needle bar is guided by needle bar bushing U ⑧ and needle bar bushing D ⑨.

2 Lower shaft and rotating hook mechanism

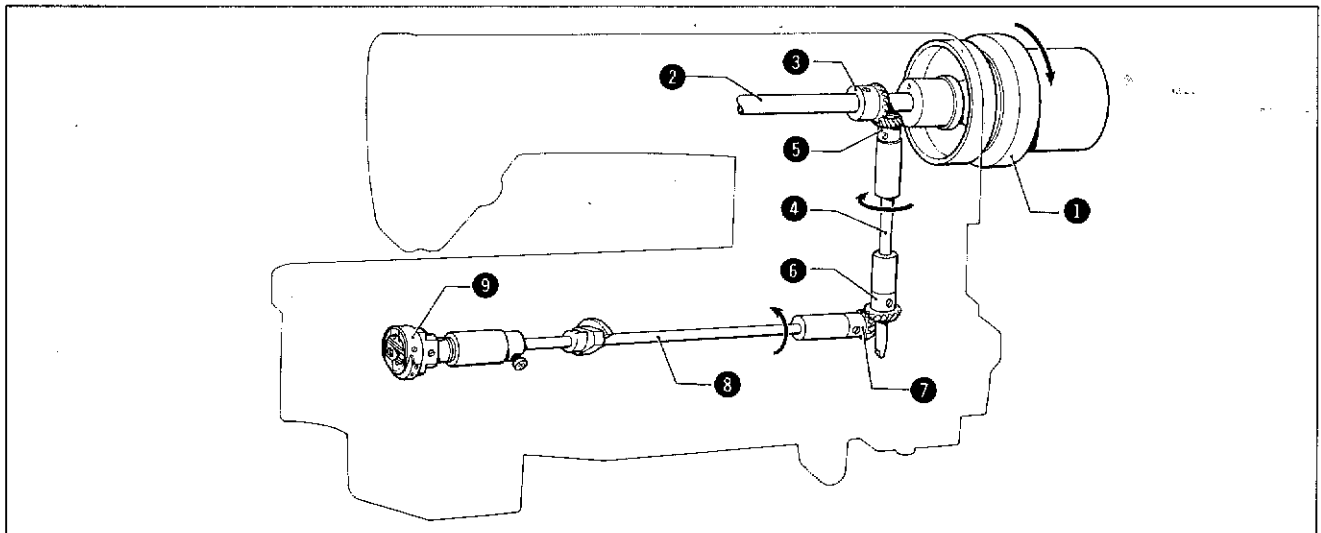

1. When the pulley ① turns in the direction indicated by the arrow, the movement is transmitted by the upper shaft bevel gear ③ mounted to the upper shaft ② to vertical shaft bevel gear U ⑤ mounted on the top of the vertical shaft ④.
2. The movement is then transmitted by vertical shaft bevel gear D ⑥ mounted on the bottom of the vertical shaft ④ to the lower shaft ⑧ via the lower shaft bevel gear ⑦.
3. The rotary hook ⑨ is then caused to rotate in a full circle by the lower shaft ⑧.

3 Feed mechanism (B714/B716/B747)

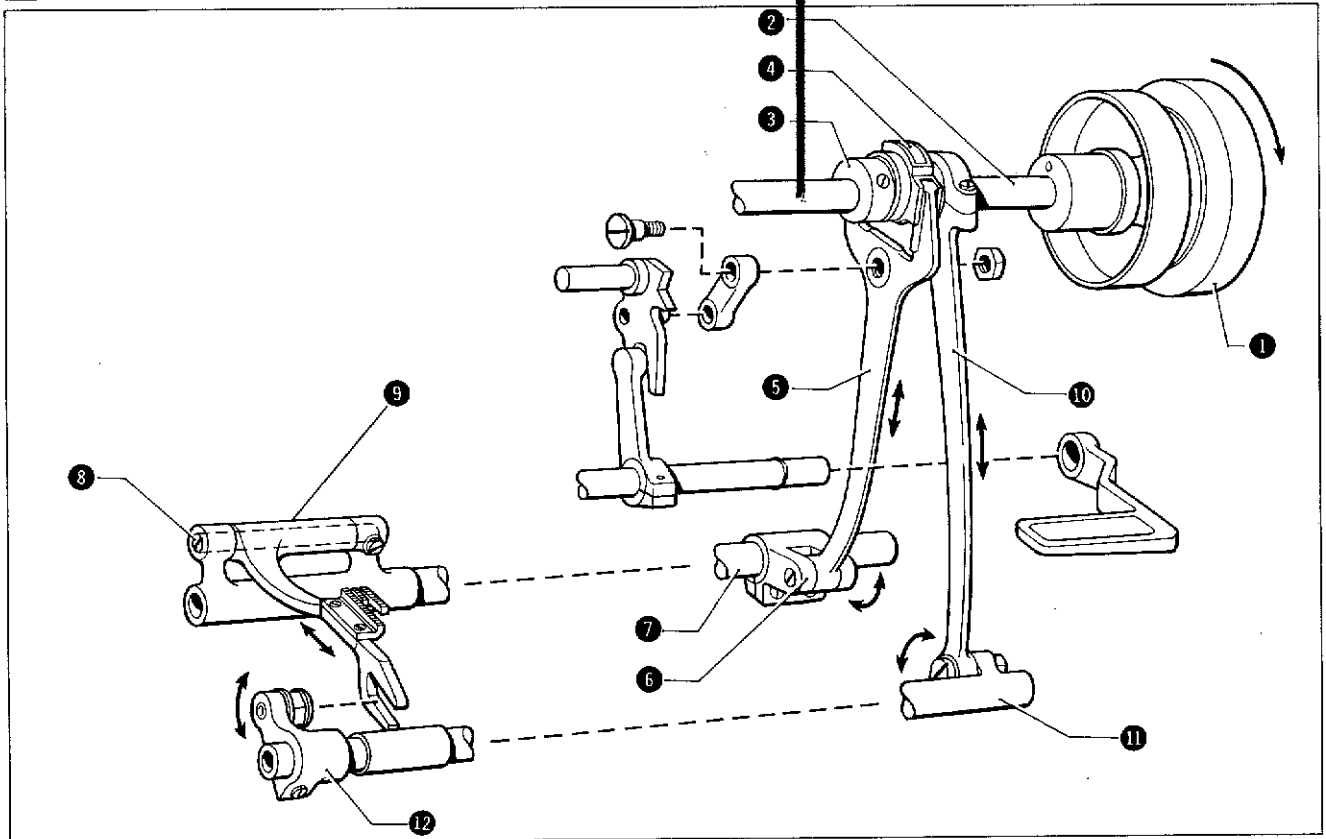

1. When the pulley ① turns in the direction indicated by the arrow, vertical movement is transmitted by the feed cam ③ mounted to the upper shaft ② to the forked connector ⑤ via the feed cam sleeve ④.
2. The horizontal feed rocker arm ⑥ connected to the forked connector ⑤ is then moved in a circular arc.
3. The feed bar ⑨ is moved back and forth by the horizontal feed bar shaft ⑧ mounted to the horizontal feed rocker shaft ⑦.
4. The crank rod ⑩ is moved up and down by the feed cam ③.
5. The horizontal feed shaft ⑪ connected to the crank rod ⑩ is then moved in a circular arc.
6. The horizontal feed arm ⑫ connected to the feed shaft ⑪ is also moved in a circular arc.
7. The movement of the feed dog mounted to the feed bar ⑨ is determined by the combined action of steps 3 and 6.

3 Feed mechanism (B706/B707)

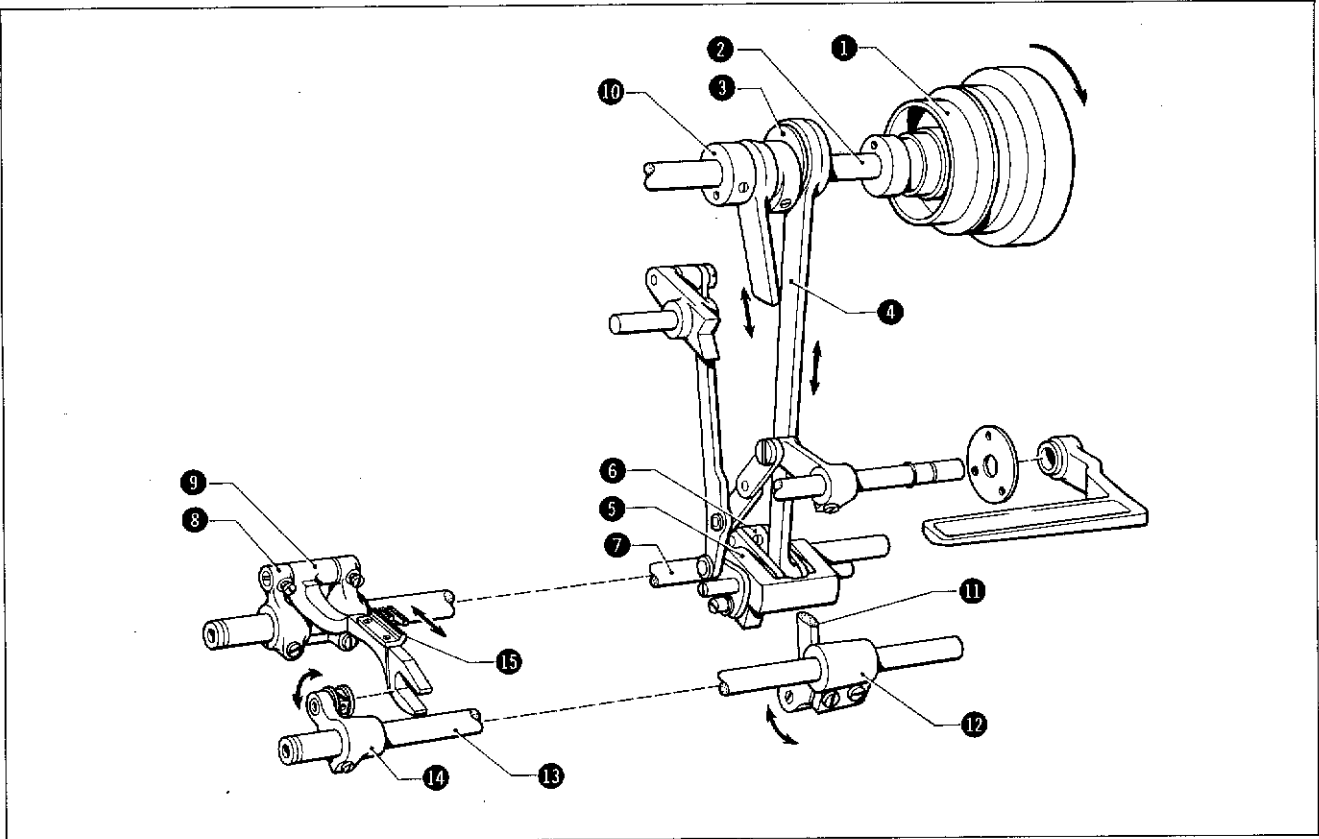

1. When the pulley ① turns in the direction indicated by the arrow, the level feed connecting rod ④ is moved up and down by the level feed eccentric wheel ③ mounted to the upper shaft ②.
2. The feed rocker shaft arm ⑥ is moved in a circular arc by the level feed arm link assembly ⑤ mounted to the level feed connecting rod ④.
3. The feed bar ⑨ is moved back and forth by the wick hanger ⑧ mounted to the feed rocker shaft ⑦.
4. The vertical feed connecting rod ⑪ is moved up and down by the vertical feed eccentric wheel ⑩ mounted to the upper shaft ②.
5. The feed lifting rocker shaft arm ⑫ is moved in a circular arc by the vertical feed connecting rod ⑪.
6. The feed bar ⑨ is moved up and down by the feed lifting arm ⑭ mounted to the feed lifting rocker shaft ⑬.
7. The movement of the feed dog ⑮ mounted to the feed bar ⑨ is determined by the combined action of steps 3 and 6.

4 Lubrication mechanism

1. Upper shaft oil supply

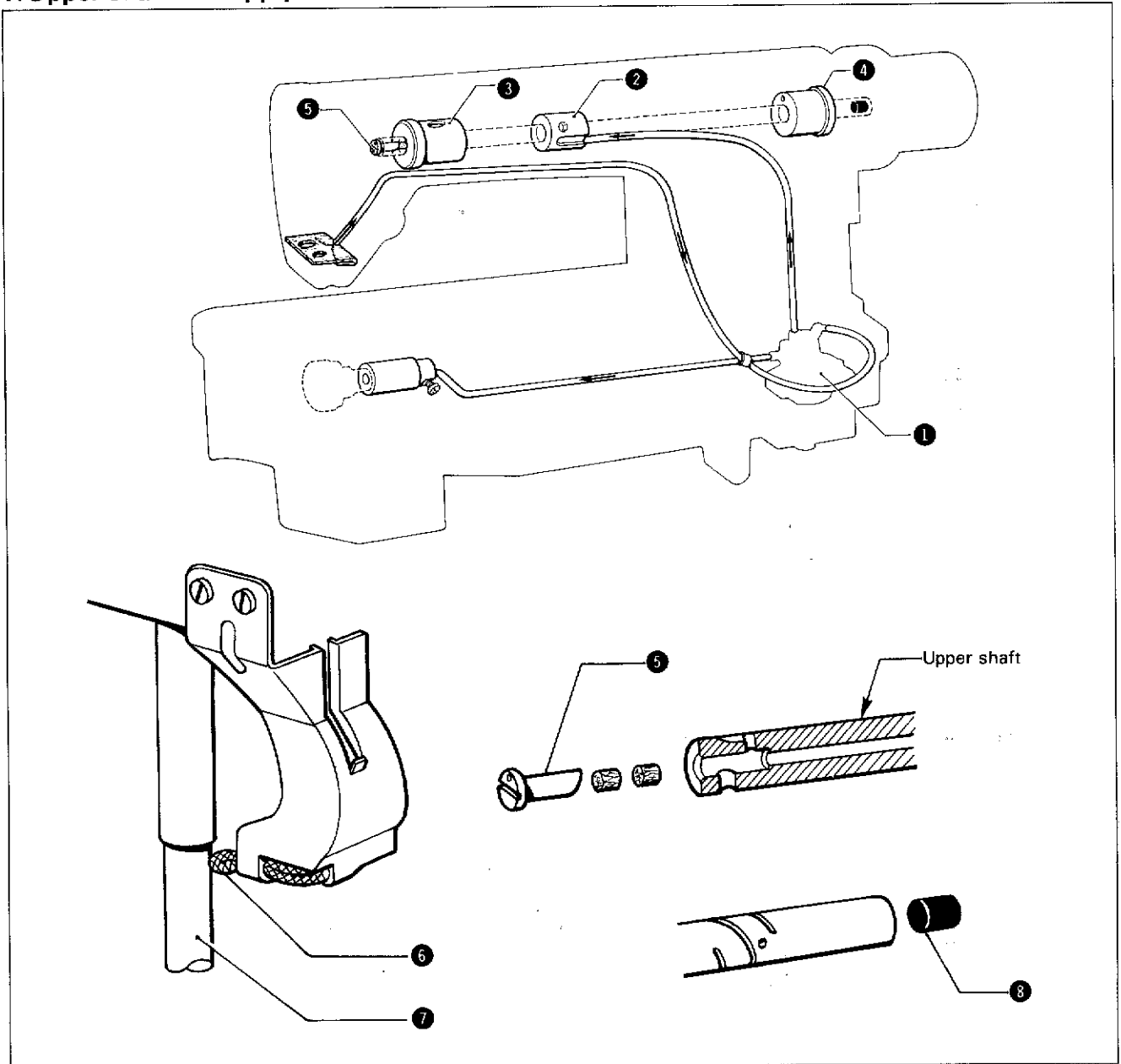

- (1) The oil from the pump ① passes through upper shaft bushing M ②, enters the center of the upper shaft, and from there is supplied to upper shaft bushing L ③ and upper shaft bushing R ④.
The oil dispersed in the arm column is supplied to the feed adjuster.
- (2) An oil adjusting valve ⑤ is provided at the left end of the upper shaft, and oil is supplied to the thread take-up arm via the counterweight and needle bar crank.
- (3) Felt is mounted on the needle bar crank in order to prevent excess oil discharge or oil clogging, and oil is supplied to the needle bar connecting rod.
- (4) The oil that accumulates in the thread take-up shield is supplied to the needle bar ⑦ and needle bar bushings U and D via the oil wick ⑥.
- (5) The oil is held inside by the rubber stopper ⑧ in the pulley presser screw at the right end of the upper shaft.
- (6) The oil that accumulates at the dip in the arm is drawn back to the pump ① via a felt and a tube.

2. Lower shaft oil supply

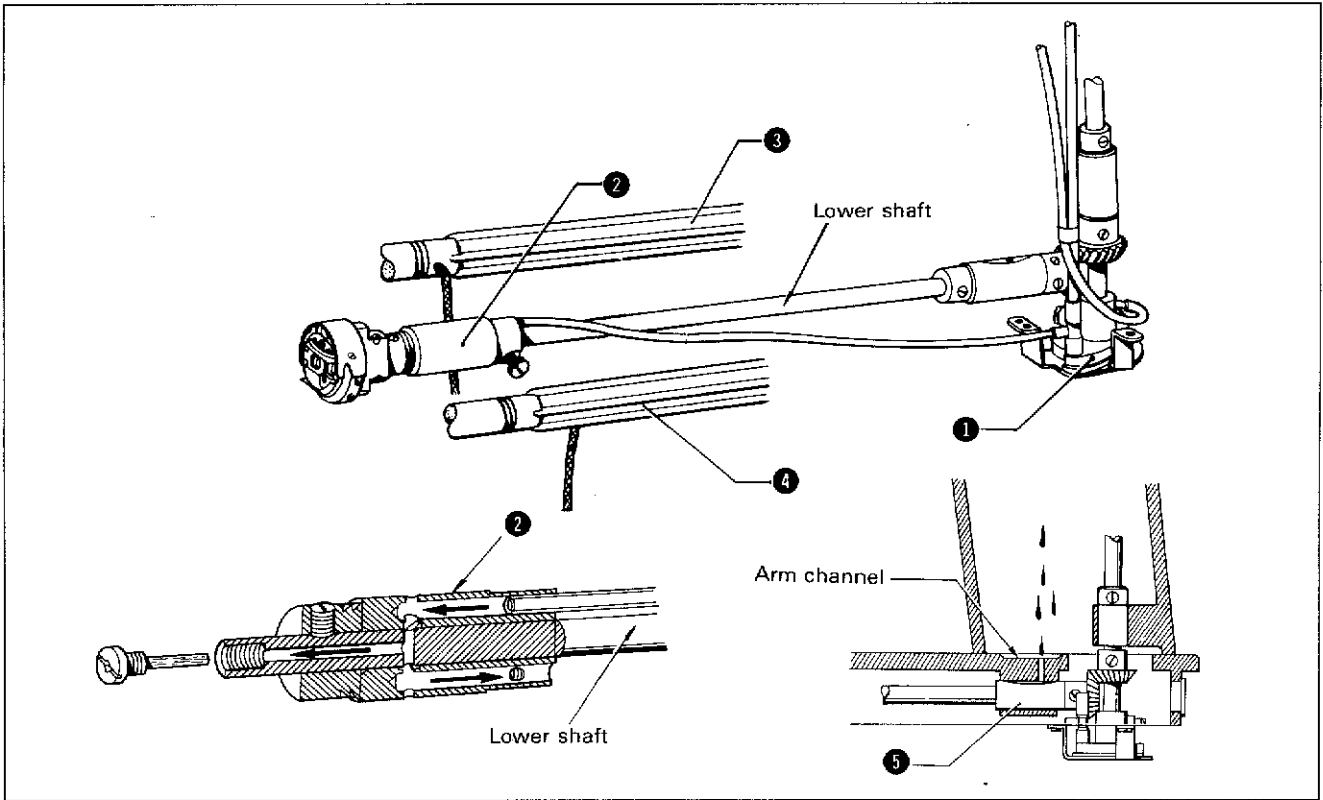

- (1) The oil is supplied by the pump to the lower shaft and lower shaft bushing L ②.
- (2) Part of the oil from lower shaft bushing L ② flows through the lower shaft to the rotary hook. Also, the oil ejected from lower shaft bushing L ② is supplied to the horizontal feed rocker shaft ③ and the vertical feed shaft ④ via a wick.
- (3) The oil dispersed in the arm column is supplied to lower shaft bushing R ⑤, the horizontal feed rocker shaft ③, and the vertical feed shaft ④ via the arm channel.

3. Pump mechanism

When the vanes at the bottom of the vertical shaft turn, the centrifugal force sucks the oil up through the hole in the center. The oil is then expelled from the outlets at the ends of the spinal chambers to the various oil tubes.

In addition, a plunger pump attached to the pump body draws oil which accumulates in the dip in the arm back to the pump.

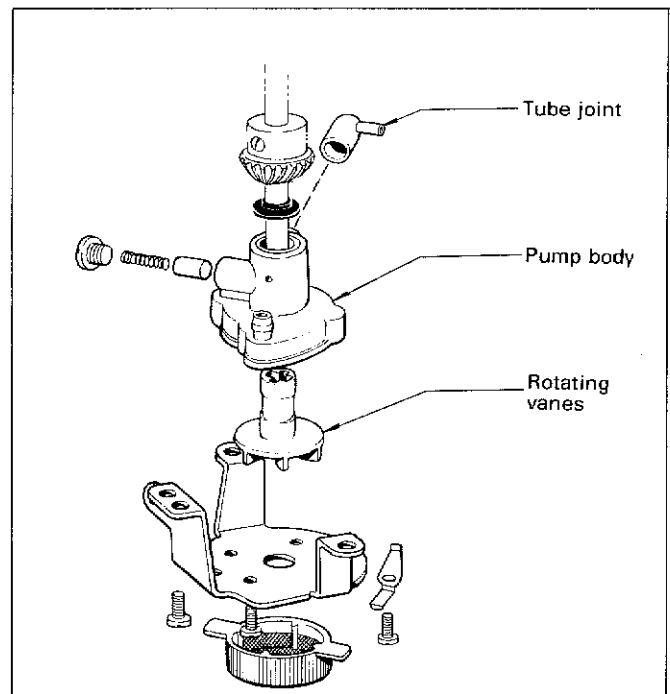

5 Thread trimmer mechanism

1. Thread trimmer mechanism

As shown in the illustration, the thread trimmer mechanism consists of the movable knife ①, the fixed knife ②, a lower thread finger ③, the movable knife holder ④, the knife holder assembly ⑤, the trimmer forked shaft ⑥, the trimmer cam lever assembly ⑦, the trimmer cam ⑧, and the trimmer solenoid ⑨.

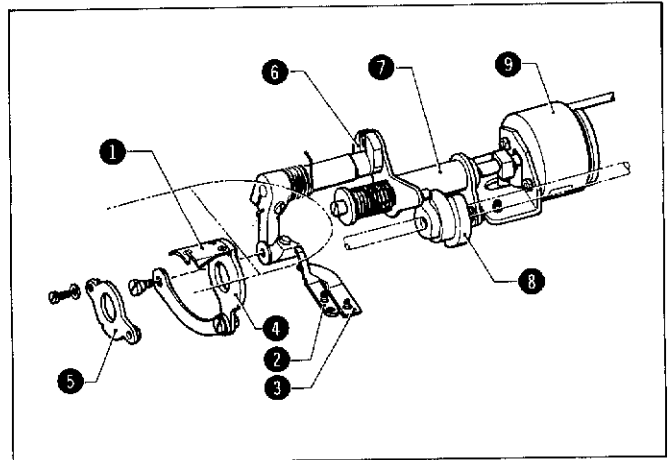

2. Operation of the trimmer mechanism (The following illustrations are with the high-speed rotating hook removed.)

(1) Condition during high-speed operation

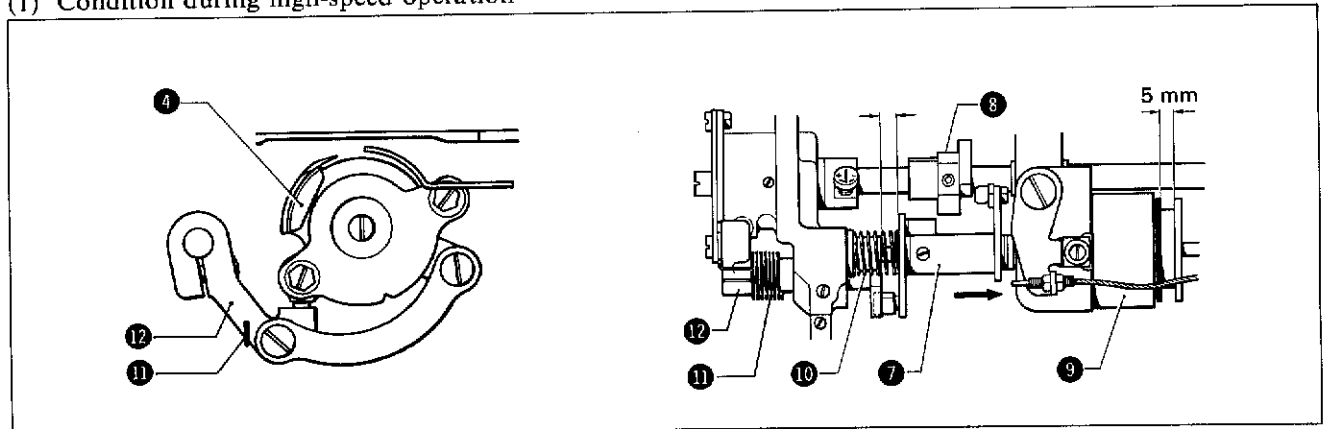

- ★ Because the trimmer cam lever assembly ⑦ is kept pressed toward the trimmer solenoid ⑨ by the cam lever return spring ⑩, the trimmer cam lever assembly ⑦ does not engage with the trimmer cam ⑧ and the movable knife holder ④ does not function.
- In addition, the trimmer lever ⑫ is pressed by the trimmer lever spring ⑪ so that the movable knife holder ④ does not move.

(2) Condition when a trim signal is input

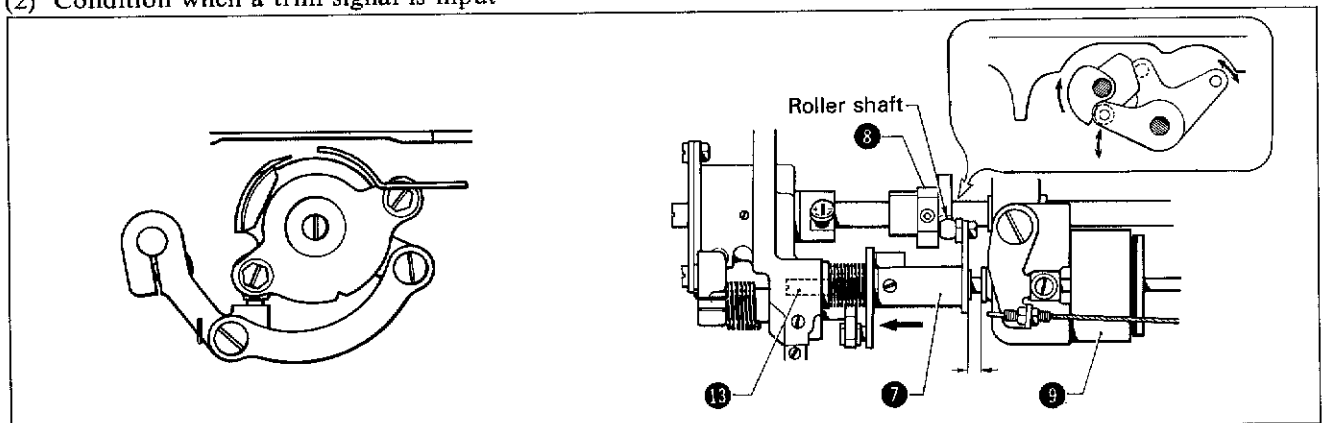

- ★ When the foot Pedal is depressed again and the trim signal is input, the trimmer solenoid ⑨ pushes the trimmer cam lever shaft ⑬. The roller shaft (right side) of the trimmer cam lever assembly ⑦ that is connected to the trimmer cam lever shaft ⑬ moves around the outside of the trimmer cam ⑧.

(3) Movement of the trimmer holder

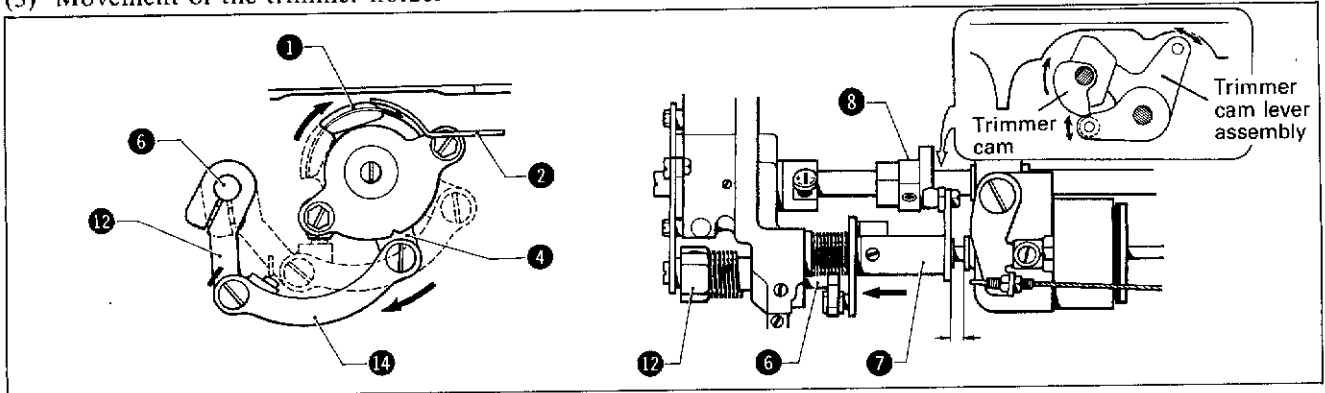

- ★ When the lower shaft turns and the trimmer cam 8 pushes the roller shaft (right side) upward, the movement is transmitted to the trimmer forked shaft 6 via the trimmer cam lever assembly 7.
- ★ The movement is transmitted to the trimmer connecting rod 14 and the movable knife holder 4 via the trimmer lever 12 mounted to the trimmer forked shaft 6.
- ★ The movable knife 1 mounted to the movable knife holder 4 moves in the direction indicated by the arrow and overlaps with the fixed knife 2.

(4) Trimming completion and stop

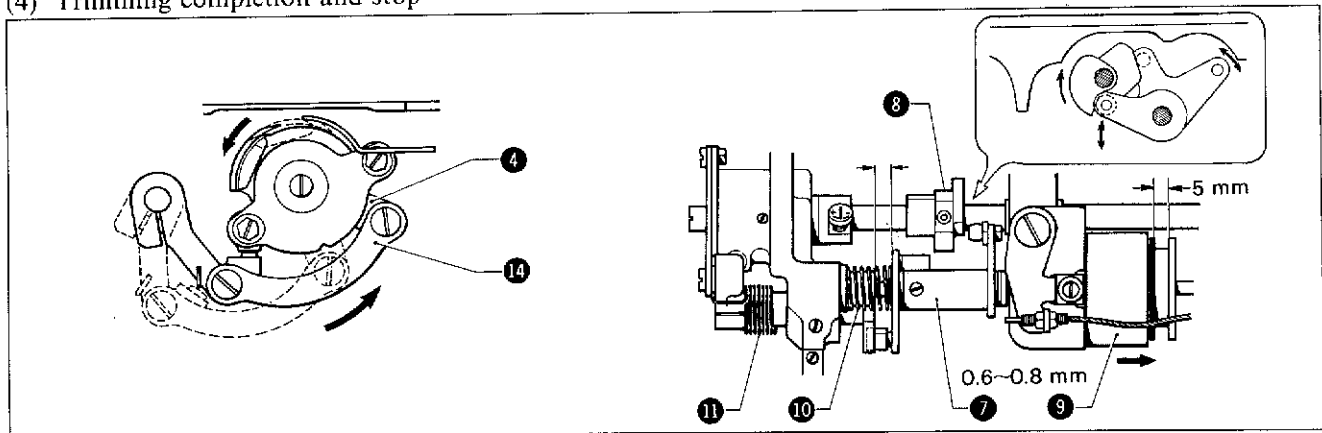

- ★ When the trim signal stops, the trimmer solenoid 9 returns, the trimmer cam lever assembly 7 is pushed by the cam lever return spring 10, and the roller shaft of the trimmer cam lever assembly 7 separates from the trimmer cam 8.
- ★ The trimmer connecting rod 14 and the movable knife holder 4 are returned to their original positions (in the directions indicated by the arrows) by the trimmer lever spring 11.

(5) Thread trimmer safety device

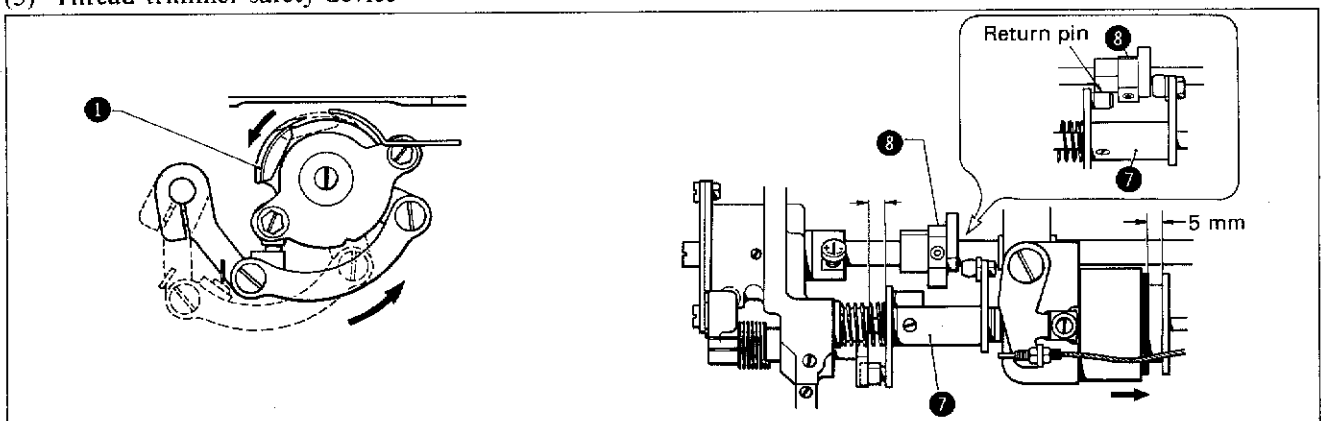

- ★ If the moving knife 1 does not return to its original position, the return pin (left side) of the trimmer cam lever assembly 7 and the trimmer cam 8 function to return the movable knife 1 to a position where it will not come in contact with the needle.

3. Operation for trimming of the needle thread and bobbin thread

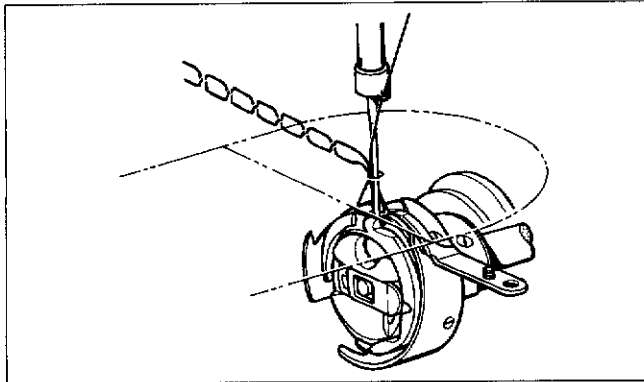

(1) The needle rises to a point 2.2 mm above the lowermost point and the tip of the rotary hook the loop formed by the needle.

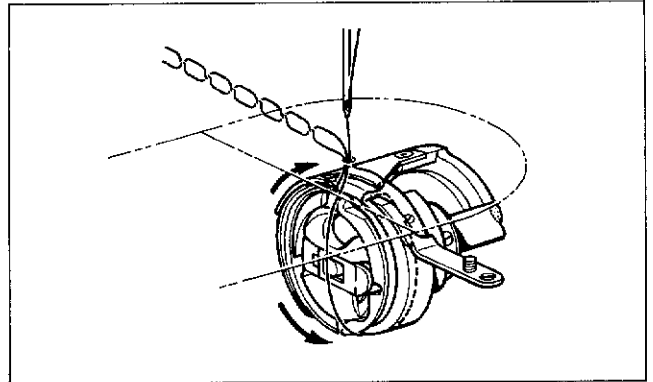

(2) The trim signal is input, and the trimmer cam causes the movable knife to move. The needle thread is caught by the rotary hook and passes through the inner hook.

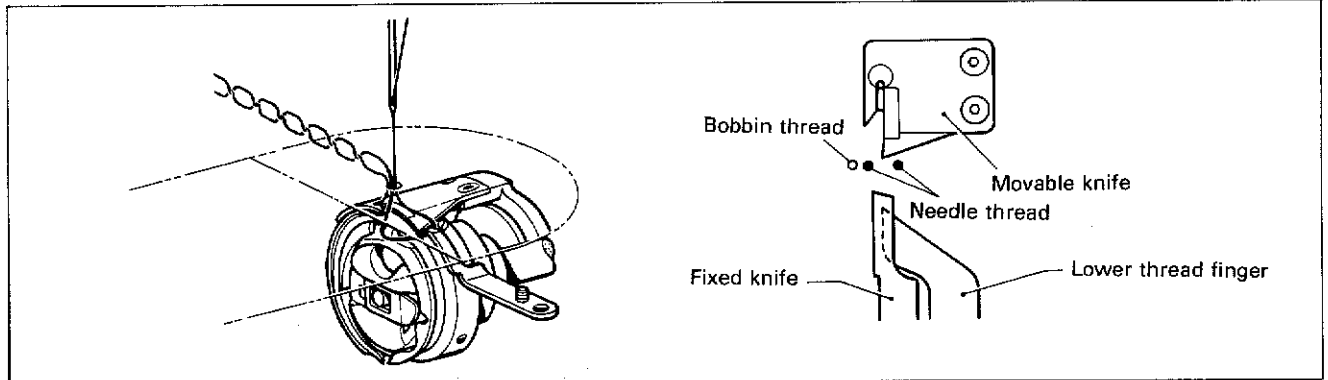

(3) The tip of the movable knife goes into the triangular loop formed by the needle and bobbin threads divided by the tip of the rotary hook at the needle hole plate, and spreads the needle and bobbin threads. At this time, the thread take-up is slightly above the lowermost position and the needle thread is separated by the movable knives as shown in the illustration. If the timing for the above operation is too early, it will affect the loop spreading of the movable knives and errors in thread trimming may occur.

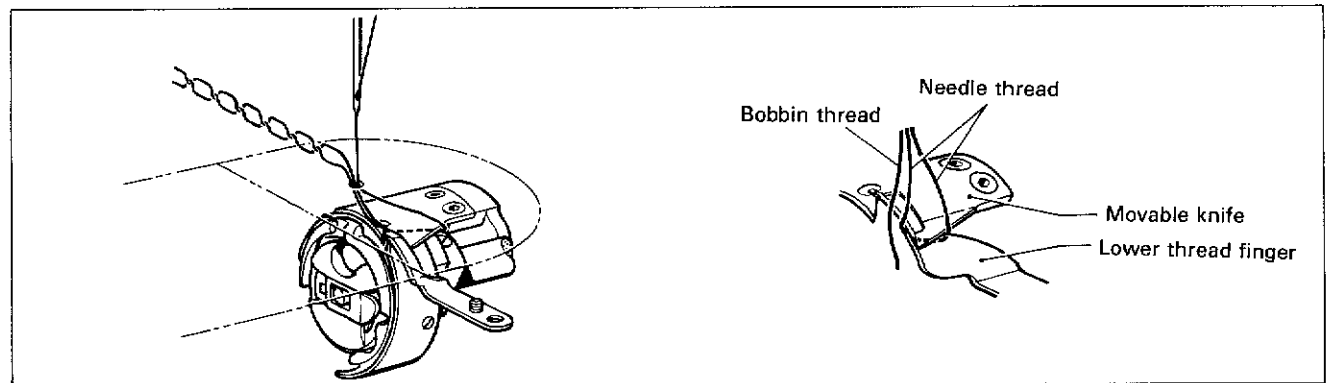
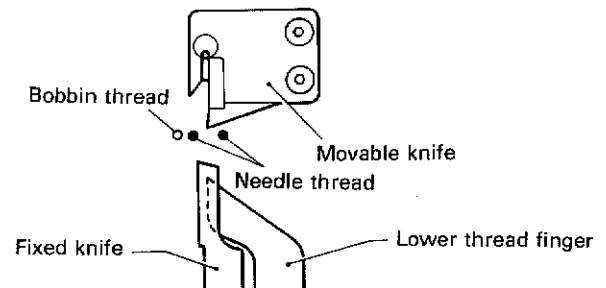

(4) The needle and bobbin threads hooked by the movable knife in step (3) are spread out to a fan shape by the shape of the knife, and as they are spread out gradually by the thread spreader, they are cut by the tip of the fixed knife. At this time, the thread take-up is almost at the uppermost position. At the same time that the knife is spreading out the thread, the tension release lever functions to let the needle thread out smoothly and prevent excessive slack. Note that the amount of thread determined at the movable knife becomes the length of thread remaining for the needle thread and in the bobbin case after thread trimming, and this in turn influences the composition of the stitch the next time sewing is begun.

6 Thread tension release lever mechanism (B707/B716/B747)

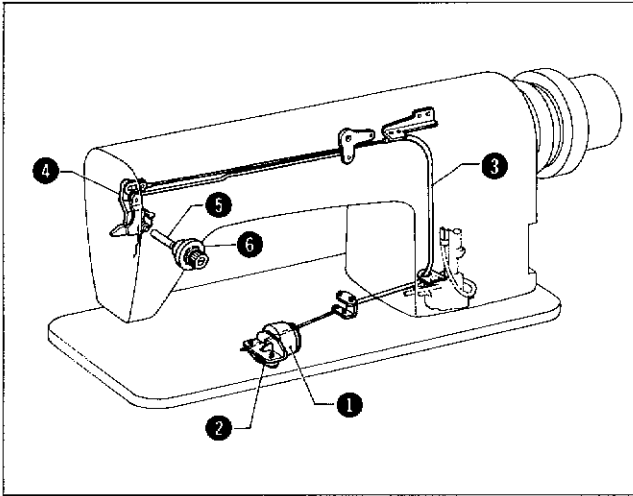

★ When trim signal is input, the trimmer solenoid ① functions, the tension release plate ④ pushes the tension release bar ⑤ via the tension release lever ② and the tension release wire ③ and opens the tension disc.

When the needle upper stop signal is input, current no longer flows to the thread trimmer solenoid, and the tension disc closes.

7 Thread wiper mechanism (B707/B716/B747)

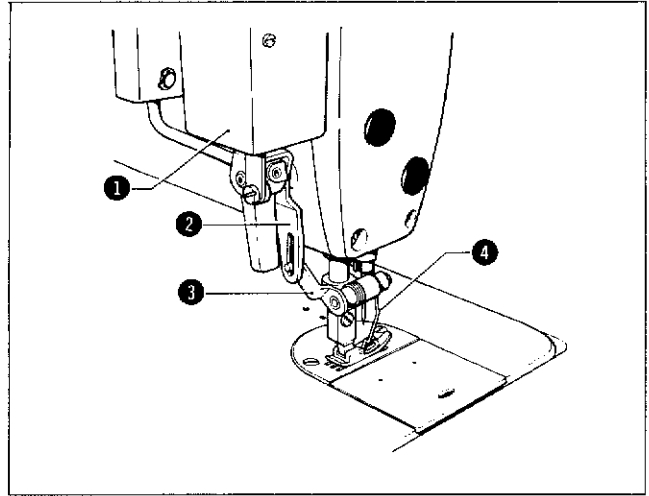

★ When the needle upper stop signal is input, there is a delay of 85 ms, and then the solenoid ① functions, the thread wiper lever ② moves the thread wiper ④ via the grooved link ③, and the needle thread is wiped on top of the material after thread trimming.

When the current stops flowing to the solenoid, the thread wiper is returned to its original position by a spring.

8 Quick-back mechanism

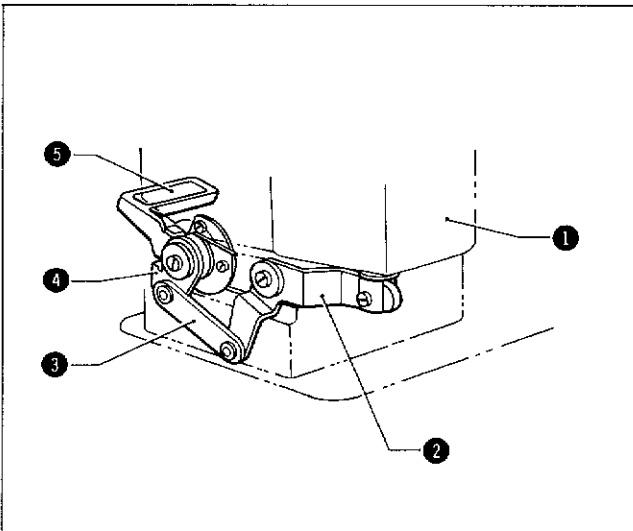

★ When the quick-back switch is pressed, the reverse solenoid ① functions, the solenoid lever plate ④ is pulled via the solenoid lever ② and the connecting link ③, and the reverse lever ⑤ is pulled downward.

While the quick-back switch remains pressed, the machine does reverse stitching. When the switch is released, it is returned to its original position by a return spring and the machine resumes forward stitching.

9 Automatic presser lifter mechanism

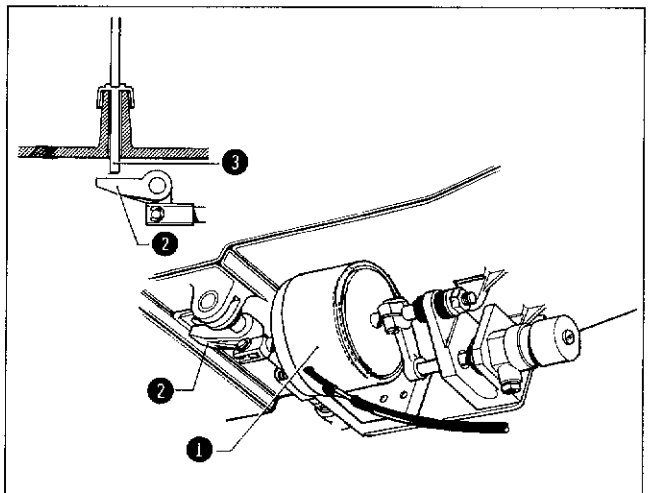

★ When the power switch is turned on, the presser lifter solenoid ① functions (ON) and the knee lifter presser bar ③ is pressed upward via the presser lifter link ②.

★ When the upper part of the foot pedal is depressed lightly, the presser lifter solenoid ① becomes OFF, the presser lifter link ② returns, and the presser drops back down.

DISASSEMBLY

1 Cover (If equipped with a thread wiper, refer to the instructions in parentheses.)

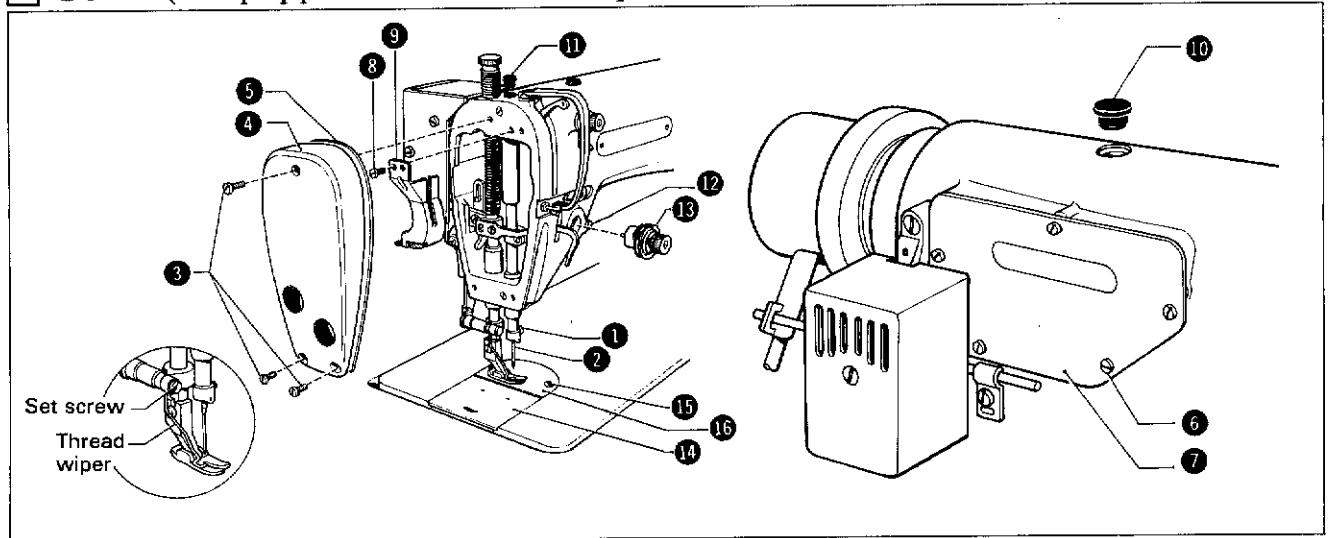

1. Loosen the set screw ① and remove the needle ②. (Loosen the set and remove the thread wiper.)
2. Remove the three screws ③, and then remove the face plate ④ and the packing ⑤.
3. Remove the five screws ⑥ and then remove the side cover ⑦.
4. Remove the two screws ⑧, and then remove the oil stopper plate ⑨.
5. Remove the oil cap ⑩ and the oil cap ⑪.
6. Loosen the set screw ⑫ and remove the tension regulator assembly ⑬.
7. Remove the slide plate ⑭.
8. Remove the two screws ⑮, and then remove the needle plate ⑯.

2 Presser

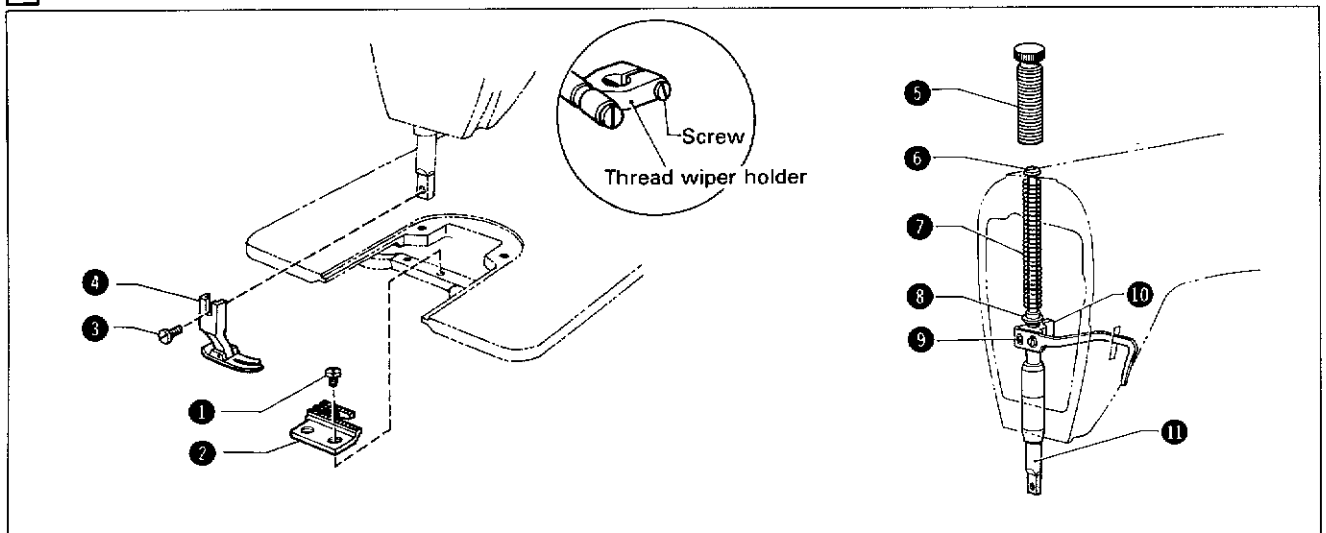

1. Loosen the two set screws ① and remove the feed dog ②. (Use the presser lifter lever to raise the presser assembly.)
2. Loosen the set screws ③ and remove the presser foot ④. (Remove the screw, and then remove the thread wiper holder.)
3. Remove the screw ⑤, and then remove the presser spring bar ⑥, the presser spring ⑦, and the washer ⑧.
4. Loosen the set screw ⑨ and remove the presser bar clamp ⑩.
5. Remove the presser bar ⑪ by extracting it from the top of the arm.

3 Rotary hook

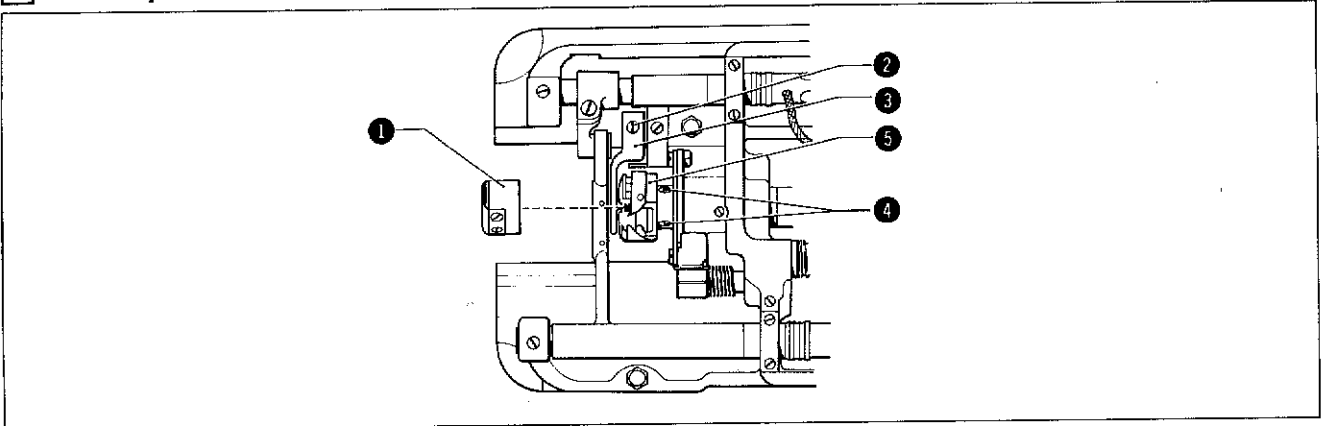

1. Tilt the machine.
2. Remove the bobbin case ①.
3. Remove the screw ②, and then remove the rotary hook position bracket.
4. Loosen the three set screws ④ and remove the rotary hook ⑤.

4 Thread trimmer

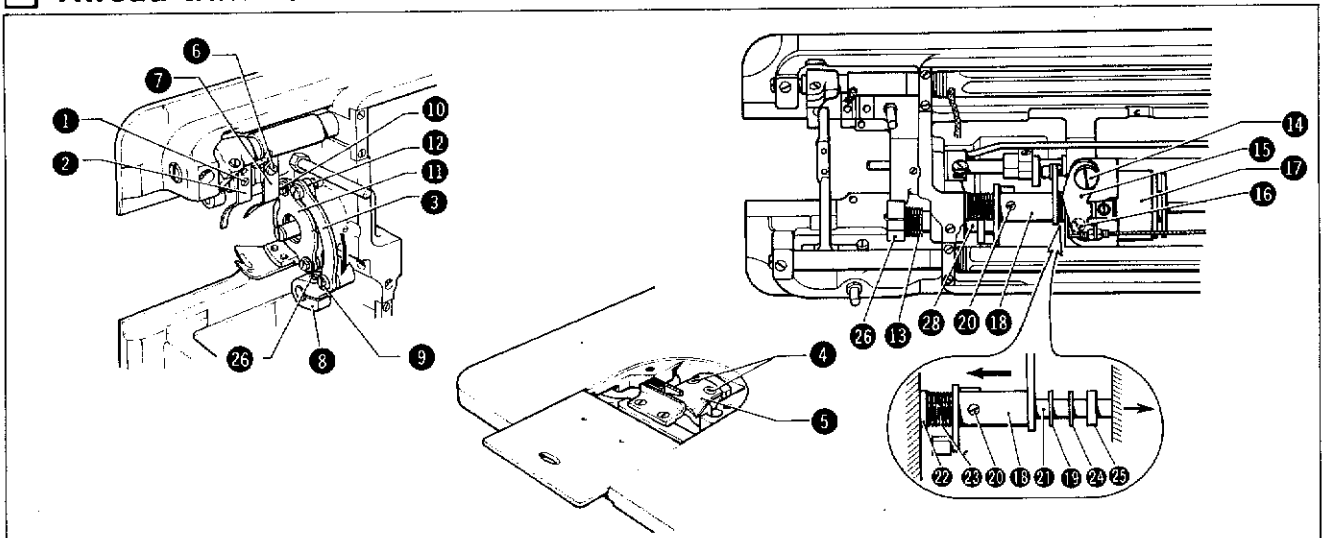

1. Remove the screw ①, and then remove the fixed knife ②.
2. Push the thread trimmer connecting rod ③ in the direction indicated by the arrow, and then position the two screws ④ where they can be seen.
3. Remove the screws ④, and then remove the movable knife ⑤.
4. Remove the screw ⑥, and then remove the lower thread finger ⑦.
5. Remove the screw ⑨ on the thread trimmer lever ⑧ side.
6. Remove the bolt ⑩, and then remove the knife holder assembly ⑪, the movable knife holder ⑫, and the trimmer connecting rod ③.
7. Remove the trimmer lever spring ⑬.
8. Remove the screw ⑭, and then remove the thread tension lever ⑮.
9. Remove the screw ⑯, and then remove the trimmer solenoid ⑰.
10. Move the trimmer cam lever assembly ⑱ in the direction indicated by the arrow, and then remove the stop ring ⑲.
11. Loosen the set screw ⑳, and then remove the trimmer cam lever shaft ㉑ toward the right side (the trimmer solenoid side).
12. Remove the collar ㉒, the cam lever return spring ㉓, the trimmer cam lever assembly ⑱, the washer ㉔, and the cushion ㉕.
13. Remove the screw ㉖, and then remove the trimmer lever ⑧, the trimmer lever spring ⑬, and the forked shaft ㉗.

5 Feed mechanism (B706/B707)

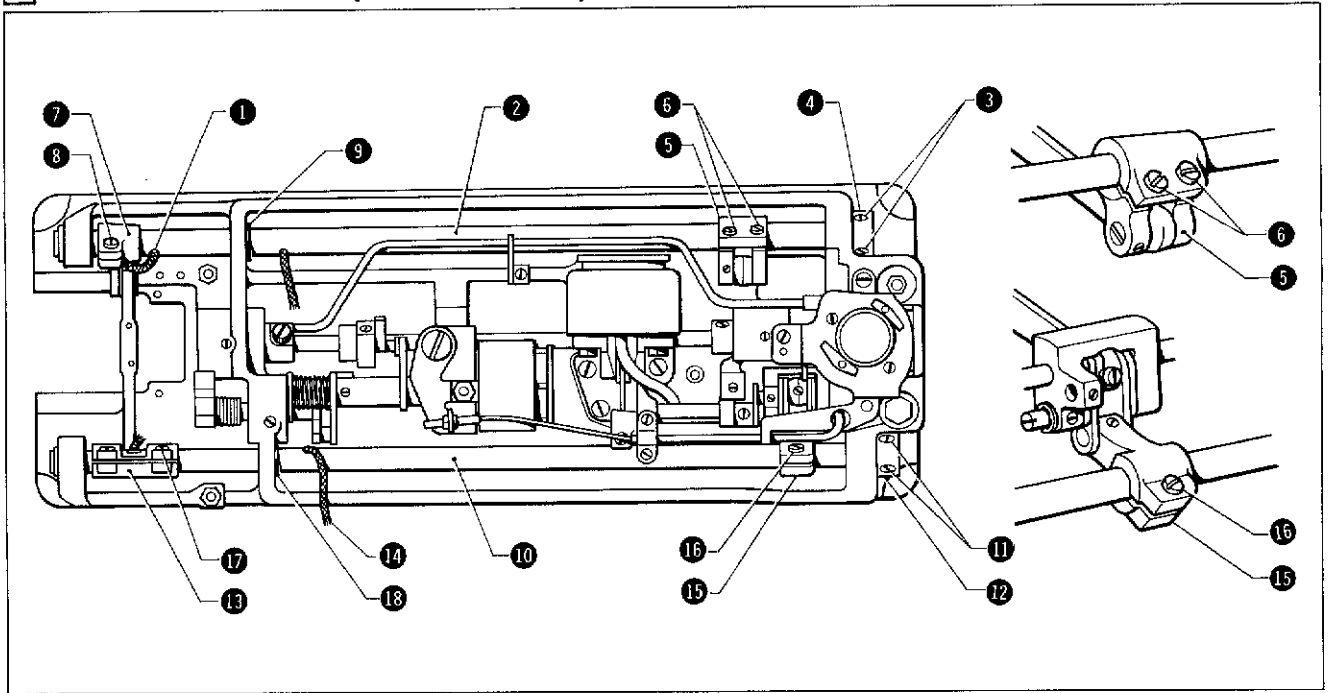

1. Remove the wick 1.
2. Loosen the two set screws 3 on the right side of the feed lifting rock shaft 2, and then remove the collar 4.
3. Loosen the two set screws 6 on the feed lifting rock shaft arm 5 and the three set screws 8 on the feed lifting arm 7.
4. Tap wedges into the notches of the feed lifting rock shaft arm 5 and the feed lifting arm 7, and then remove the feed lifting rock shaft 2 toward the left side. (The oil rejector 9 and the feed lifting arm 7 will also come off.)
5. Loosen the two set screws 11 on the right side of the feed rock shaft 10, and then remove the collar 12.
6. Remove the wick 14 from the feed bar arm 13.
7. Loosen the set screw 16 on the feed rock shaft arm 15 and the two set screws 17 on the feed bar arm 13.
8. Tap wedges into the notches in the feed rock shaft arm 15 and the feed bar arm 13, and then remove the feed rocker shaft j toward the left. (The oil rejector 18 and the feed bar arm 13 will also come off.)

5 Feed mechanism (B714/B716/B747)

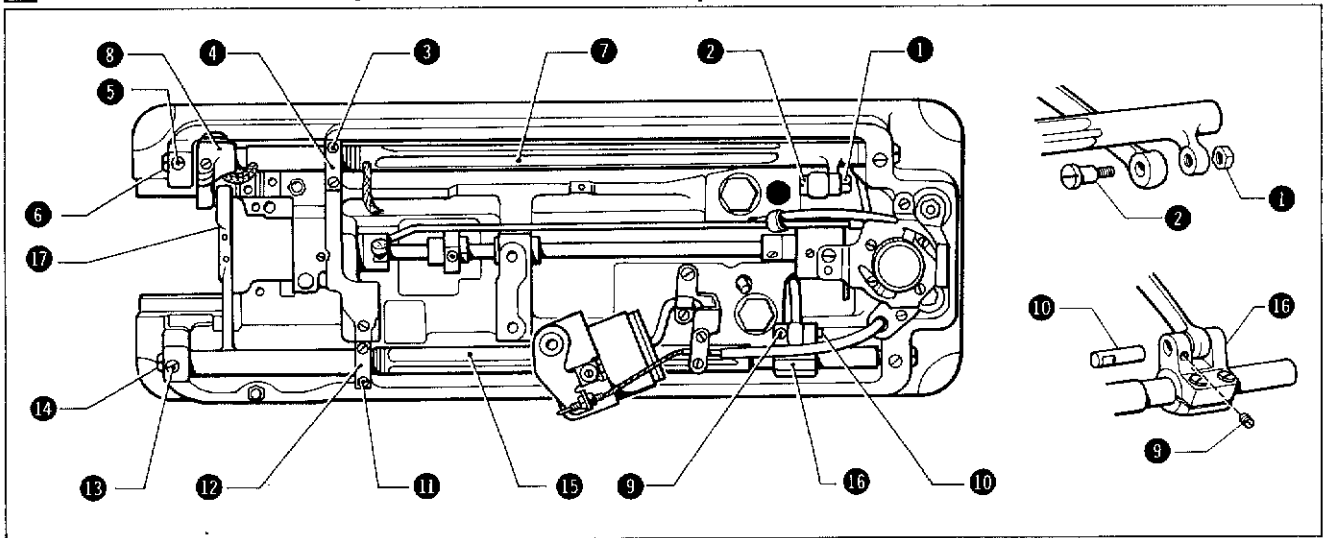

1. Loosen the nut ①, and remove the screw ②.
2. Remove the two set screws ③, and remove the oil stopper ④.
3. Loosen the set screw ⑤, rotate the taper pin ⑥, and remove the feed lifting rock shaft ⑦ and feed lifting arm ⑧.
4. Loosen the set screw ⑨, and remove the feed arm pin ⑩.
5. Remove the two set screws ⑪, and remove the oil stopper ⑫.
6. Loosen the set screw ⑬, disconnect the taper pin ⑭, and remove the feed rock shaft ⑮, feed rock shaft arm ⑯, and feed bar ⑰.

6 Needle bar mechanism

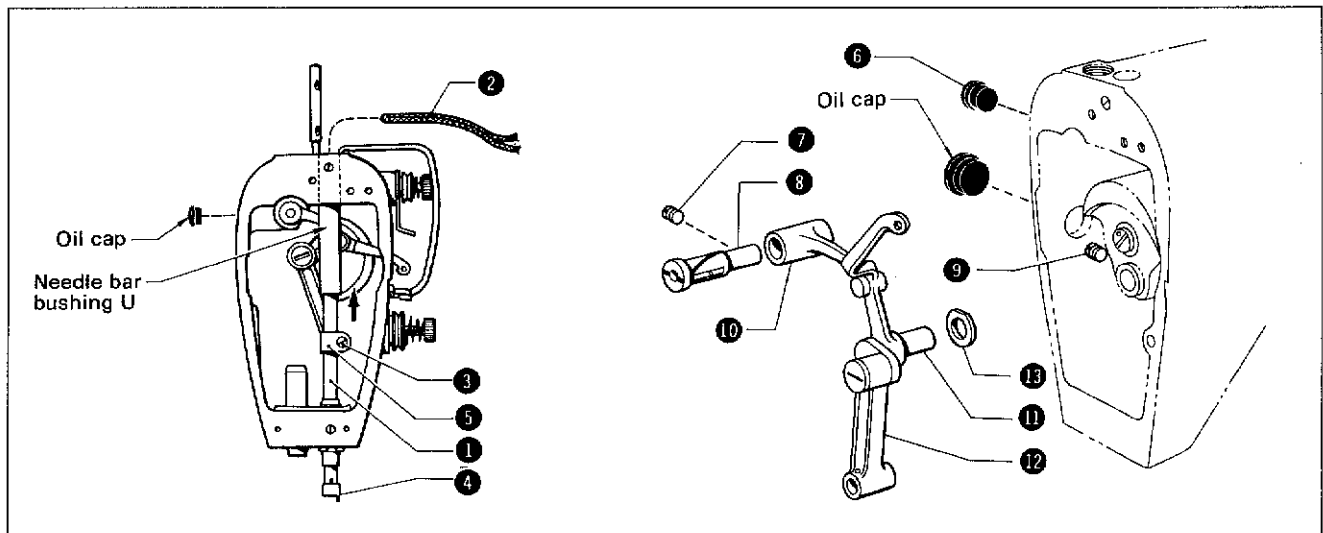

1. Tilt the machine.
2. Remove the needle bar thread guide ④.
3. Remove the wick ② from the top of the needle bar bushing U.
4. Loosen the set screw ③, and remove the needle bar ①, and needle bar clamp ⑤. (Remove the slide block.)
5. Remove the oil cap ⑥, loosen the set screw ⑦ and remove the thread take-up support pin ⑧.
6. Remove the oil cap and loosen the two set screws ⑨. Now remove the thread take-up rocking arm ⑩, needle bar crank ⑪, needle bar connecting rod ⑫, and washer ⑬.

ASSEMBLY

1 Needle bar

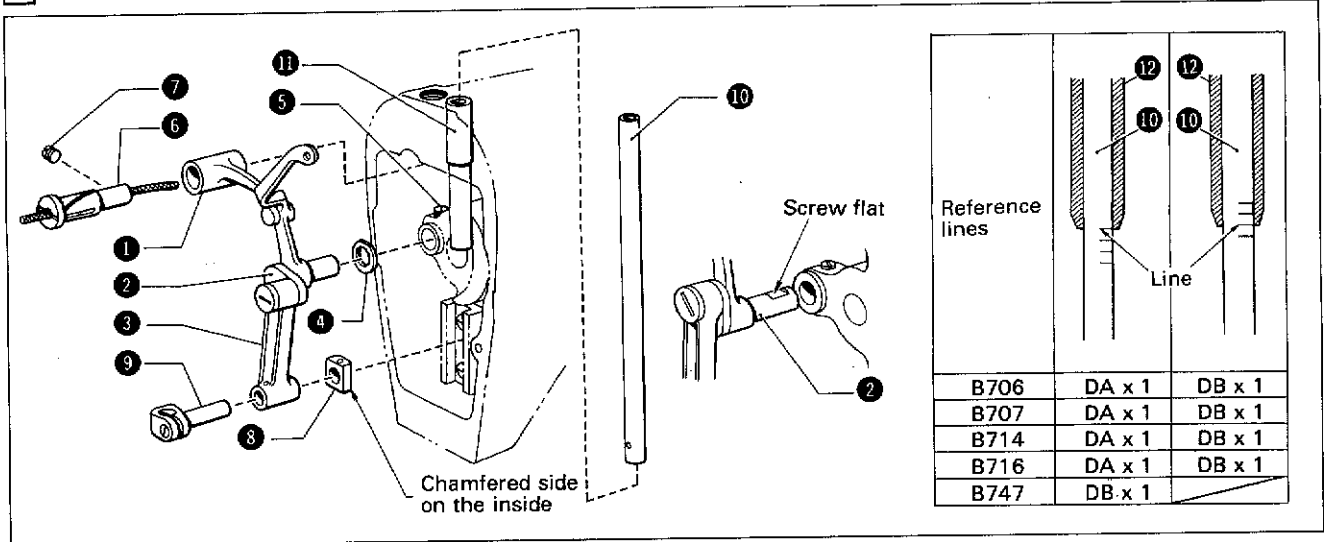

1. Install the thread take-up arm assembly ①, the needle bar crank ②, the needle bar connecting rod ③, and the washer ④ with the set screw ⑤.
- * Refer to the above illustration for the position of the needle bar crank ② screw flat.
2. Thread the wick through the thread take-up lever support shaft ⑥. (Refer to the illustration.)
3. Fit the thread take-up lever support shaft ⑥ through the thread take-up arm assembly ①, and then secure it with the set screw ⑦.
4. Fit the block ⑧ into the groove, and then fit the needle bar clamp ⑨ through the needle bar connecting rod ③ and the block ⑧.
(Fit the block into the groove with the chamfered side toward the inside.)
5. Fit the needle bar ⑩ into needle bar bushing U ⑪ from the top, and then pass it through the needle bar clamp ⑨.
6. Pass the wick through from needle bar bushing U ⑪. (Refer to the illustration.)
7. Turn the pulley and set the needle bar to the lowermost position.
8. Align the second reference line from the bottom on the needle bar ⑩ with the bottom end of needle bar bushing D ⑫.

⊙ Threading the wicks

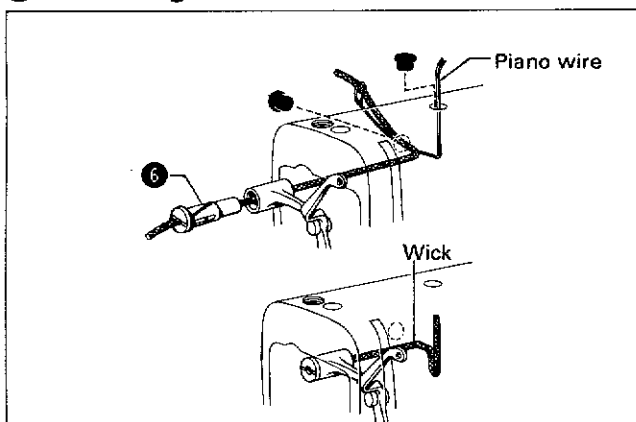

- (1) Thread the wick through the thread take-up arm assembly ⑥.
- (2) Thread the wick into the machine while installing the thread take-up arm assembly ⑥.
- (3) Insert a length of piano wire into the oil hole and pull out the wick as shown in the illustration.
- (4) Align the end of the wick with the edge of the thread take-up arm assembly ⑥ and insert the rest of the wick into the oil hole.

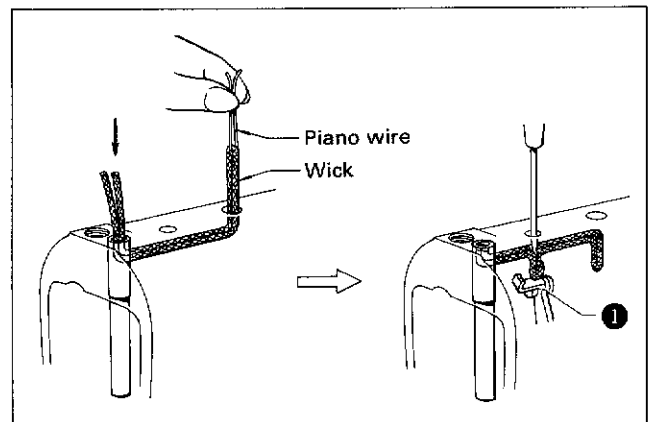

- (1) Thread the wick through the upper end of the needle bar bushing.
- (2) Manually turn the pulley and set the thread take-up to the uppermost position.
- (3) As shown in the illustration, insert the wick until it contacts the top of the thread take-up arm assembly ①.
- (4) Insert the end of the wick into the oil hole.

2 Feed mechanism (B706/B707)

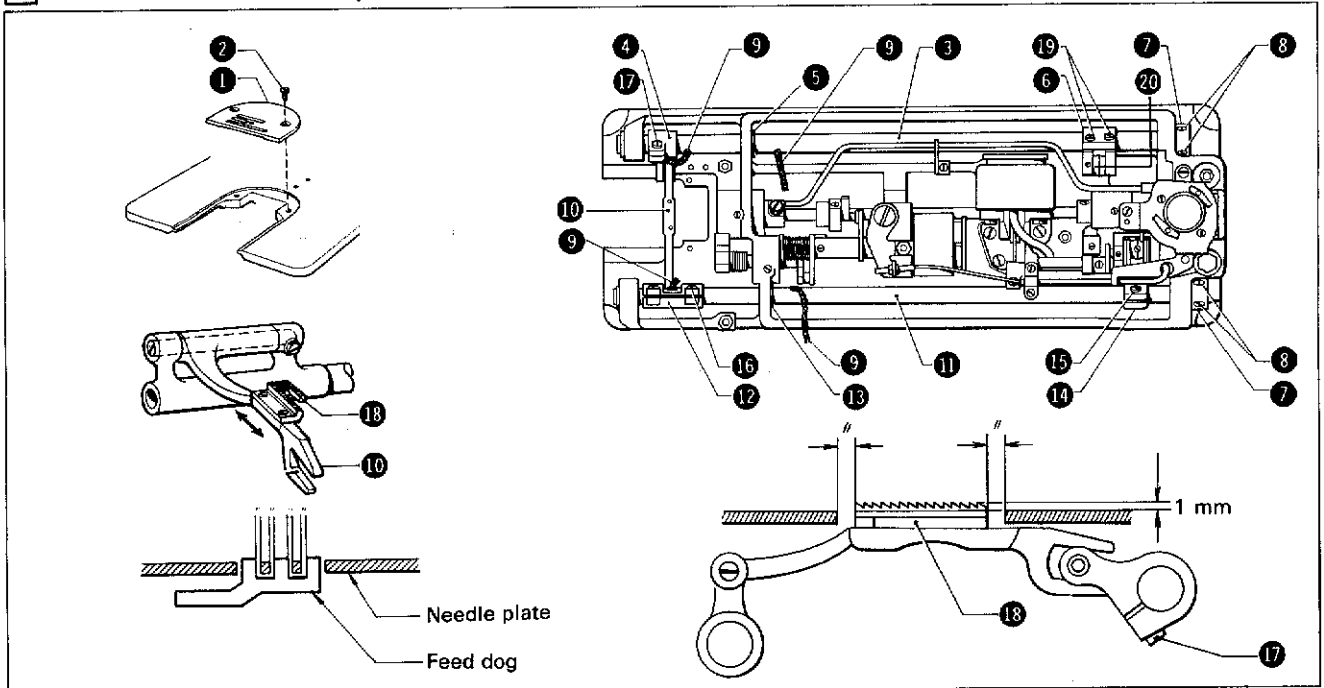

1. Install the needle plate ① with the screws ②.
2. Tilt the machine.
3. Mount the feed lifting rock shaft ③ (from the left side), the feed lifting arm ④, the oil rejector ⑤, and the feed lifting rock shaft arm ⑥.
4. Mount the set collar ⑦ onto the feed lifting rock shaft ③, and then secure it with the screw ⑧ so that it moves easily with no play.
5. Connect the wick ⑨ to feed lifting rock shaft ③. (Refer to the illustration below.)
6. Fit the forked part of the feed bar ⑩ onto the roller on the end of the feed lifting arm ④.
7. Mount the feed rock shaft ⑪ (from the left side), the feed bar arm ⑫, the oil rejector ⑬, and the horizontal feed rock shaft arm ⑭.
8. Fit the feed rock shaft ⑪ into the set collar ⑦, and then secure it with the screw ⑧ so that it moves easily with no play.
- * Secure the feed rock shaft arm ⑭ with the screw ⑮ in a position where the level feed arm link assembly moves easily.
- * Secure the feed lifting arm ④ and the feed bar arm ⑫ with the screws ⑯ in a position where the feed dog ⑱ divides the groove in the needle plate ① front to back and left to right. In addition, tighten the screw ⑰ so that the feed dog ⑱ projects 1 mm out of the needle plate ①.
9. Connect the wick ⑨ to the feed lifting rock shaft ③. (Refer to the diagram below.)
- * Secure the feed lifting rock shaft arm ⑥ with the screws ⑲ in a position where the vertical feed connecting rod ⑳ moves easily.

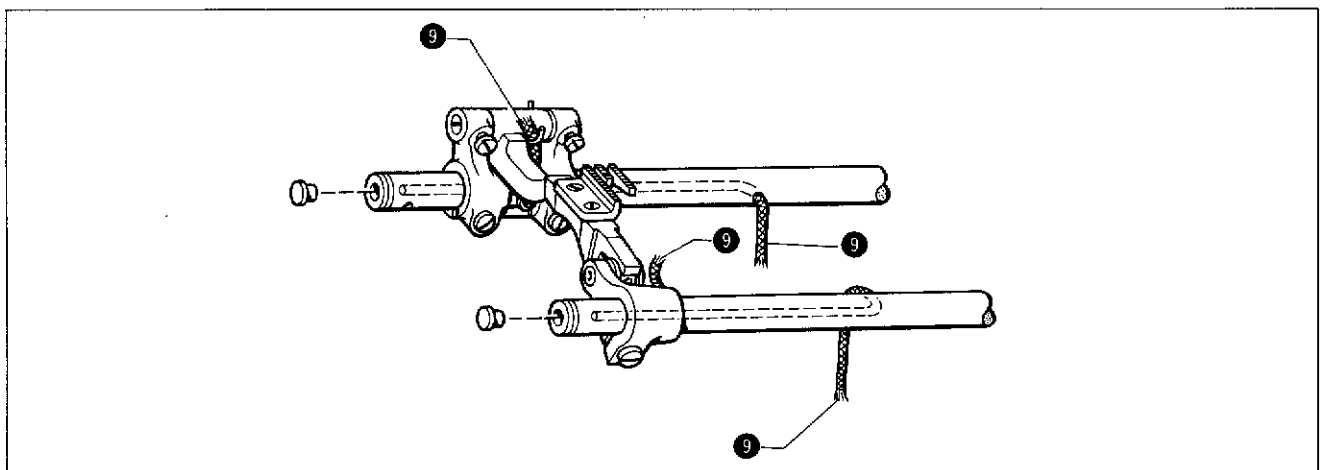

2 Feed mechanism (B714/B716/B747)

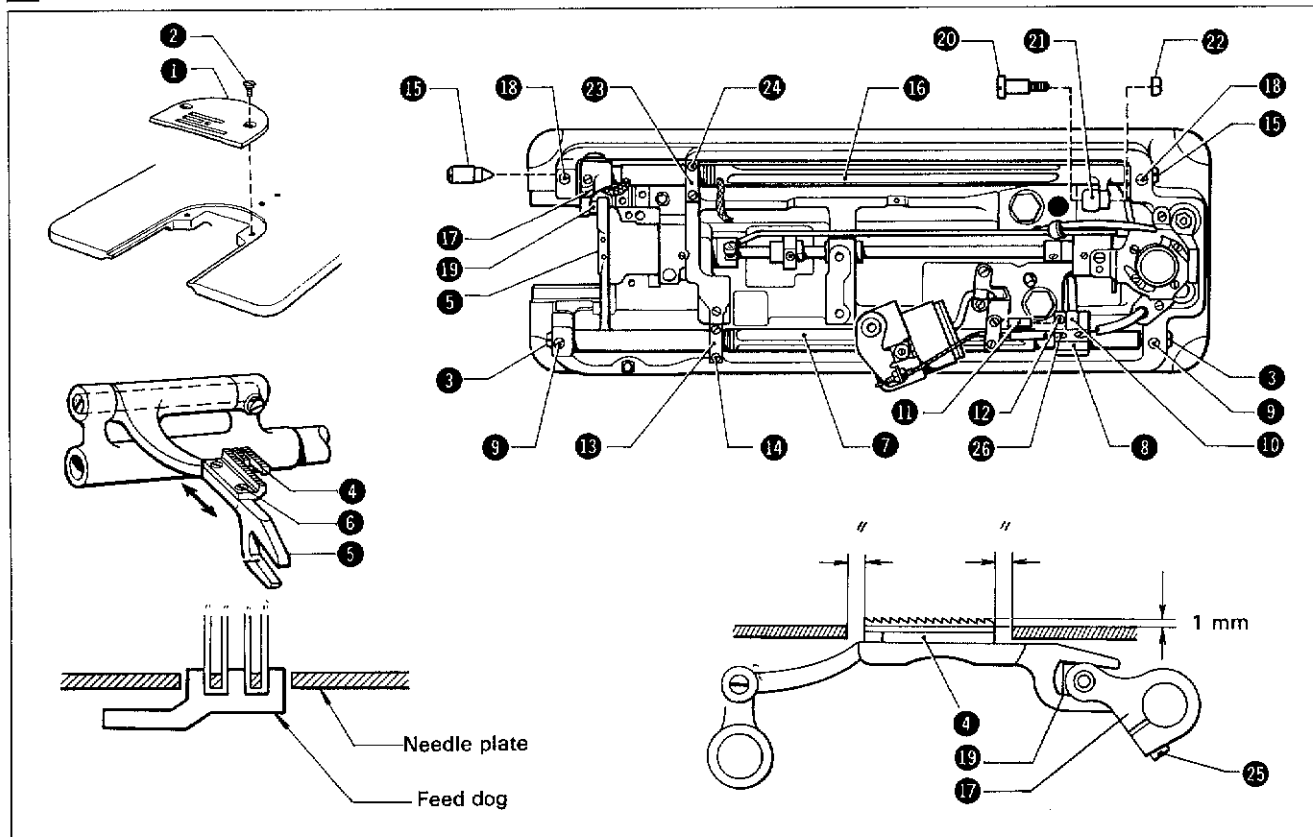

1. Install the needle plate ① with the screws ②.
2. Tilt the machine.
3. Mount the taper pin ③ onto the arm bed.
4. Mount the feed dog ④ onto the feed bar ⑤ with the screws ⑥.
5. Secure the feed rock shaft ⑦, the feed rock shaft arm ⑧, and the feed bar ⑤, with the set screw ⑨ so that they move easily with no play on the taper pin ③. (At this time, adjust the feed dog ④ so that it divides the groove in the throat plate into left and right.)
6. Fit the forked shaft ⑩ into the forked part of the feed rock shaft arm ⑧, and then secure the feed rock shaft arm pin ⑪ with the set screw ⑫.
7. Mount the oil stopper ⑬ with the screws ⑭.
8. Mount the taper pin ⑮ onto the arm bed.
9. Mount the feed lifting rock shaft ⑯ and the feed lifting arm ⑰ with the set screw ⑱ so that they move easily with not play on the taper pin ⑮.
10. Fit the side block ⑲ of the feed lifting arm ⑰ into the forked part of the feed bar ⑤, and then confirm that it slides easily.
11. Fit the screw ⑳ into the crank rod ㉑ and the feed lifting rock shaft ⑯, and then secure it with the nut ㉒.
12. Install the oil stopper ㉓ with the screws ㉔.
13. Turn the pulley and loosen the screw ㉕ to adjust the feed dog ④ so that it extends 1 mm out of the top of the needle plate.
14. Set the length control dial to the highest setting and turn the pulley.
15. Loosen the screw ㉖ and adjust the feed rock shaft ⑦ so that the feed dog ④ divides the groove in the needle plate in half front to back.

3 Thread trimmer

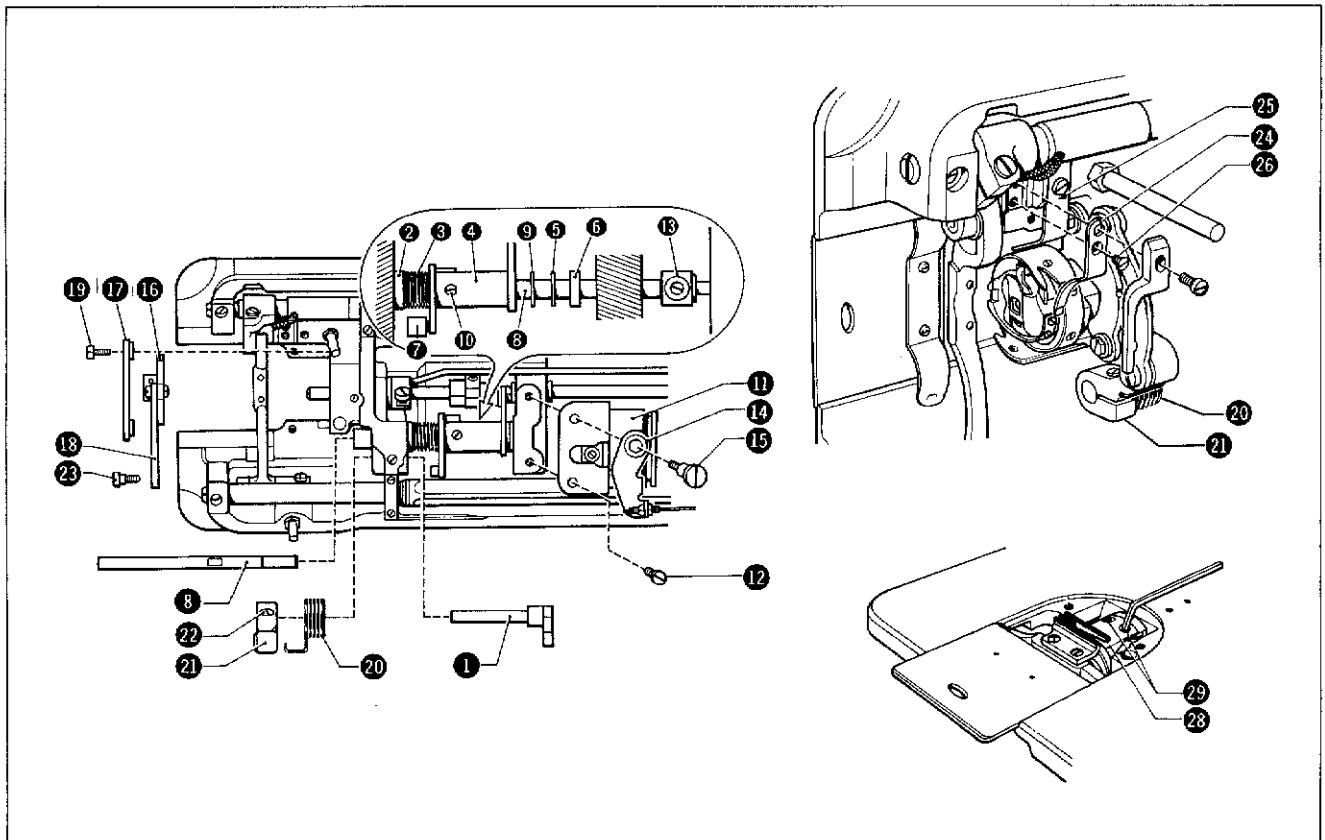

1. Fit the forked shaft ① into the arm bed.
 2. Mount the collar ②, the cam lever return spring ③, the trimmer cam lever assembly ④, the washer ⑤ and the cushion ⑥ onto the arm bed, and then mount the trimmer cam lever shaft ⑧ (after fitting the slide block ⑦ of the trimmer cam lever assembly ④ into the fork of the forked shaft ①).
 3. Fit the stop ring ⑨ onto the trimmer cam lever shaft ⑧.
 4. Tighten the set screw ⑩.
 5. Mount the thread trimmer solenoid ⑪ to the arm bed with the screw ⑫.
Mount the solenoid so that the gap between the trimmer cam lever shaft ⑧ and the solenoid lever ⑬ on the trimmer solenoid ⑪ is as small as possible.
 6. Mount the tension releasing lever ⑭ with the screw ⑮. (Refer to p.23 for instructions on adjusting the tension releasing lever.)
 7. Mount the movable knife holder ⑯ onto the arm bed, and then mount the knife holder assembly ⑰ (and then trimmer connecting rod ⑱) with the bolt ⑲.
 8. Mount the trimmer lever spring ⑳ and the trimmer lever ㉑ onto the forked shaft ① and secure them with the screw ㉒.
 9. Mount the thread trimmer connecting rod ⑲ to the thread trimmer lever ㉑ with the screw ㉓.
 10. Mount the lower thread finger ㉔ to the arm bed with the screw ㉕.
 11. Mount the fixed knife ㉖ to the arm bed with the screws ㉗.
 12. Mount the movable knife ㉘ to the movable knife holder ⑯ with the screws ㉙.
 13. Hook the trimmer lever spring ㉒ onto the trimmer lever ㉑.
 14. Confirm that the position of the trimmer cam is correct.
- * Move the lower thread finger ㉔ towards the movable knife in order to maintain the space between it and the rotary hook.

◆ Thread trimmer timing adjustment

1. Thread trimmer cam position adjustment

★ Turn the pulley, and then when the needle bar rises 5 mm above the lowermost position, press the thread trimmer solenoid 11 and adjust the thread trimmer cam 30 so that the roller shaft contacts the cut out part of the thread trimmer cam 30 and the end of the cam and the end of the roller shaft is 0.6 to 0.8 mm when the thread trimmer cam lever assembly returns.

2. Fixed knife and moving knife position adjustments

★ The end of the fixed knife 26 and the blade of the movable knife 28 must be in the position shown in Fig. A when the roller shaft of the thread trimmer cam lever assembly 4 moves up the thread trimmer cam 30. (The mating mark on the movable knife holder 16 must be in alignment with the mating mark on the knife holder assembly 17). If the positions do not agree with those in Fig. A, move the thread trimmer lever 21 and tighten the screw 22 so that the end of the fixed knife 26 and the blade of the movable knife 28 agree with the position in Fig. A when the roller shaft moves up the thread trimmer cam 30.

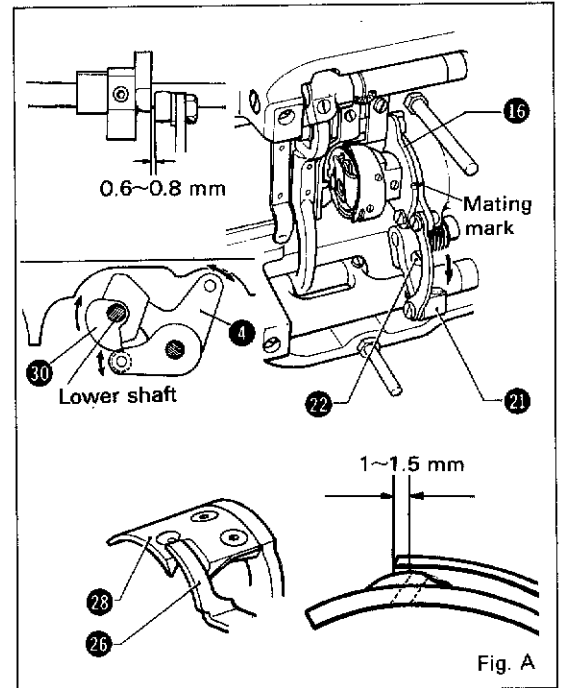

4 Rotary hook

Bottom of the needle bar bushing

Reference lines	12	12
B706	DA x 1	DB x 1
B707	DA x 1	DB x 1
B714	DA x 1	DB x 1
B716	DA x 1	DB x 1
B747	DB x 1	

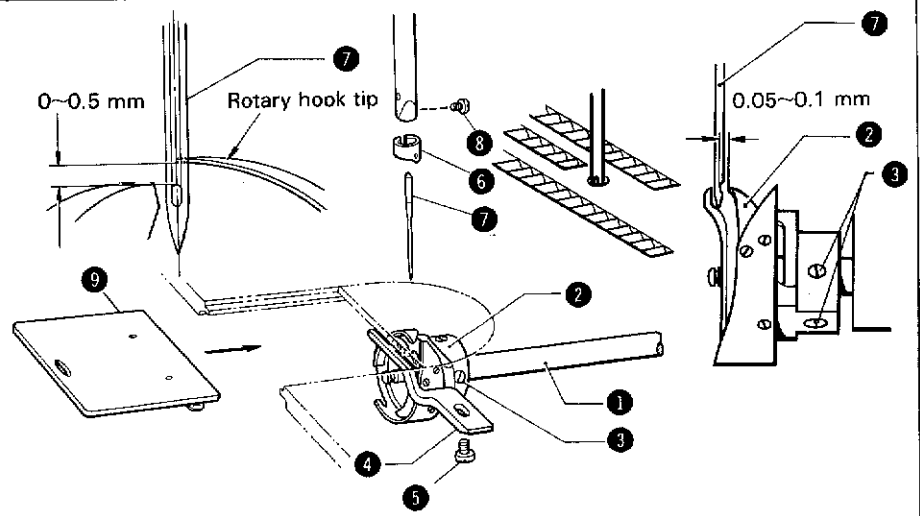

1. Mount the needle plate.
 2. Mount the rotary hook 2 onto the lower shaft 1 and secure it with the screw 3.
 3. Mount the rotary hook position bracket 4 with the screws 5.
 4. Mount the needle bar thread guard 6 onto the needle bar, and then secure the needle 7 with the set screw 8.
 5. Turn the pulley so that the needle bar rises from the lowermost position and align the needle bar reference line with the bottom of the needle bar bushing as shown in the illustration.
 6. Align the rotary hook point with the center of the needle 7.
At this time, adjust so that the distance between the rotary hook point and the upper edge of the eye of the needle is 0 to 0.5 mm and the distance between the needle 7 and the rotary hook tip is 0.05 to 0.1 mm.
 7. Mount the needle plate.
 8. Mount the slide plate 9.
 9. Adjust the feed timing.
Turn the pulley forward and adjust so that the tip of the needle is aligned with the upper surface of the needle plate when the feed dog finishes the feed and begins to retract and the tip of the feed dog is aligned with the upper surface of the needle plate. (Refer to the timing adjustment on p.21.)
- * Confirm that the gap between the rotary hook position bracket 4 and the rotary hook 2 is just enough for the thread being used to pass through easily.

5 Presser mechanism

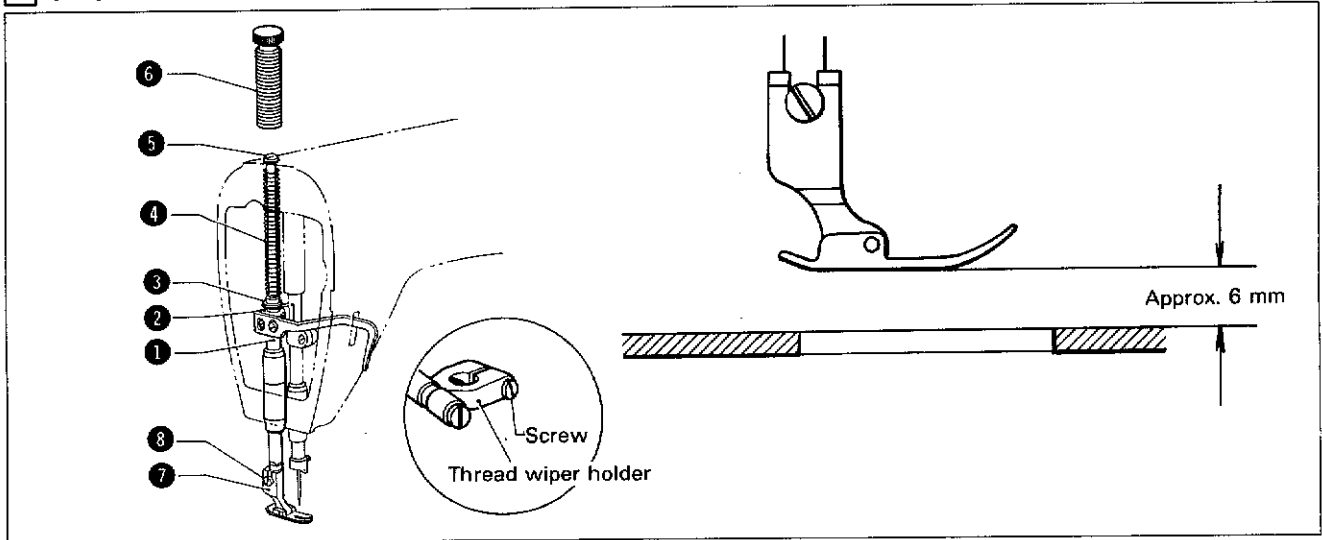

1. Insert the presser bar ① from the top of the arm.
2. Mount the presser bar guide bracket ② onto the groove in the arm, and then pass the presser bar ① through the presser bar guide bracket ②.
3. Mount the washer ③, the presser bar spring ④, and the presser bar spring guide ⑤, and then tighten the presser foot adjustment screw ⑥.
(Mount the thread wiper holder onto the presser bar ① and secure it with the screw.)
4. Mount the presser foot ⑦ onto the presser bar ① with the screw ⑧.
5. Adjust the height of the presser foot ⑦ to approximately 6 mm.

6 Cover

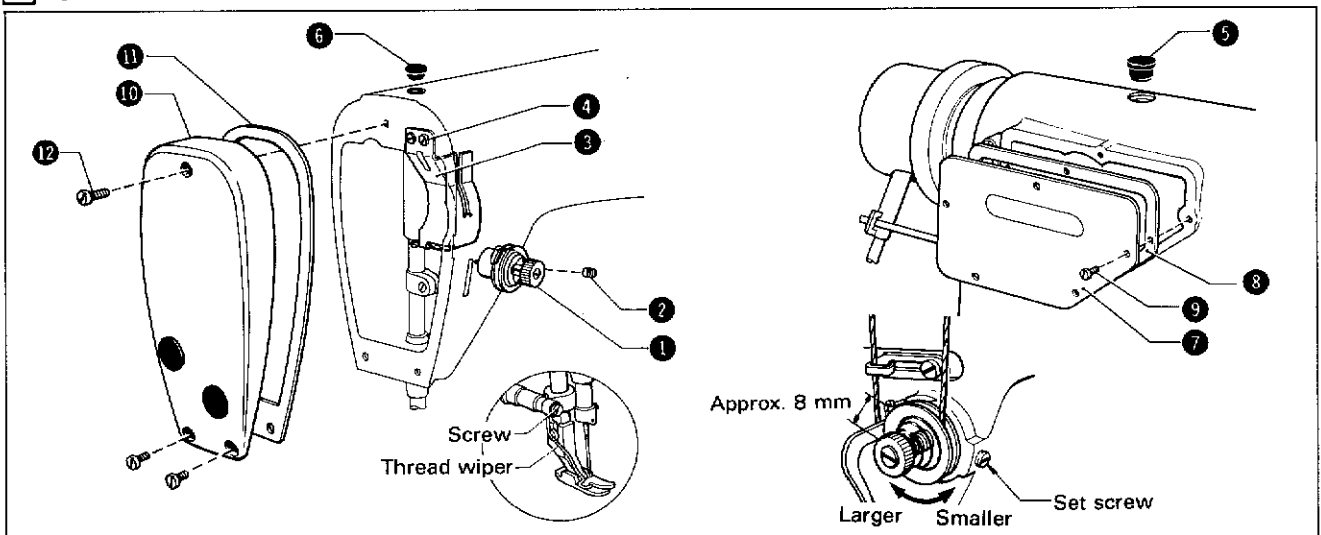

1. Mount the tension regulator assembly ① with the screw ②.
(The thread take-up spring operating range is 8 mm and the tension is 20 to 30 kg.)
2. Mount the oil stopper plate ③ with the screws ④.
3. Mount the oil cap ⑤ and the oil cap ⑥.
4. Mount the rear cover ⑦ and the packing ⑧ with the screws ⑨.
5. Mount the face plate ⑩ and the packing ⑪ with the screws ⑫.
(Mount the thread wiper with the screw.)

ADJUSTMENTS

I Needle and rotary hook timing adjustments

In order for the tip of the rotary hook to catch the loop in the needle thread when the needle rises from the lowest point, the needle and rotary hook must be correct.

1. Needle bar height

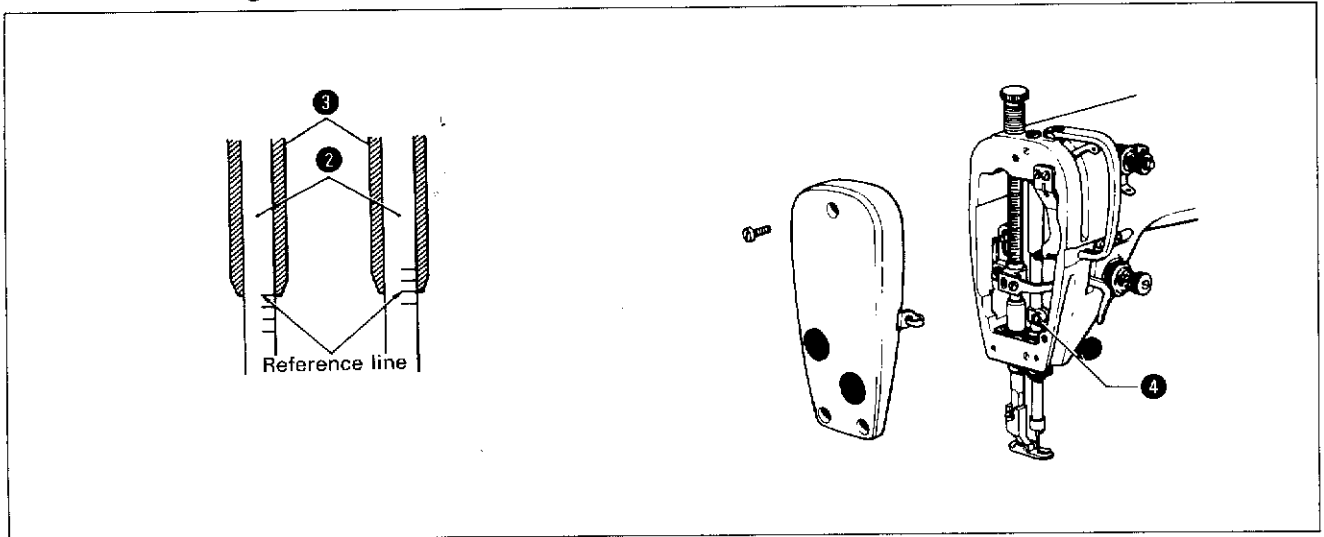

- ★ Turn the pulley slowly, and lower the needle bar ② to the needle down position. Confirm that the second from bottom reference line on the needle bar ② is aligned with the bottom of the needle bar bushing.
- Loosen set screw ④ and align this second reference line with the bottom of the needle bar bushing ③. After adjusting, firmly tighten set screw ④.

2. Rotary hook position

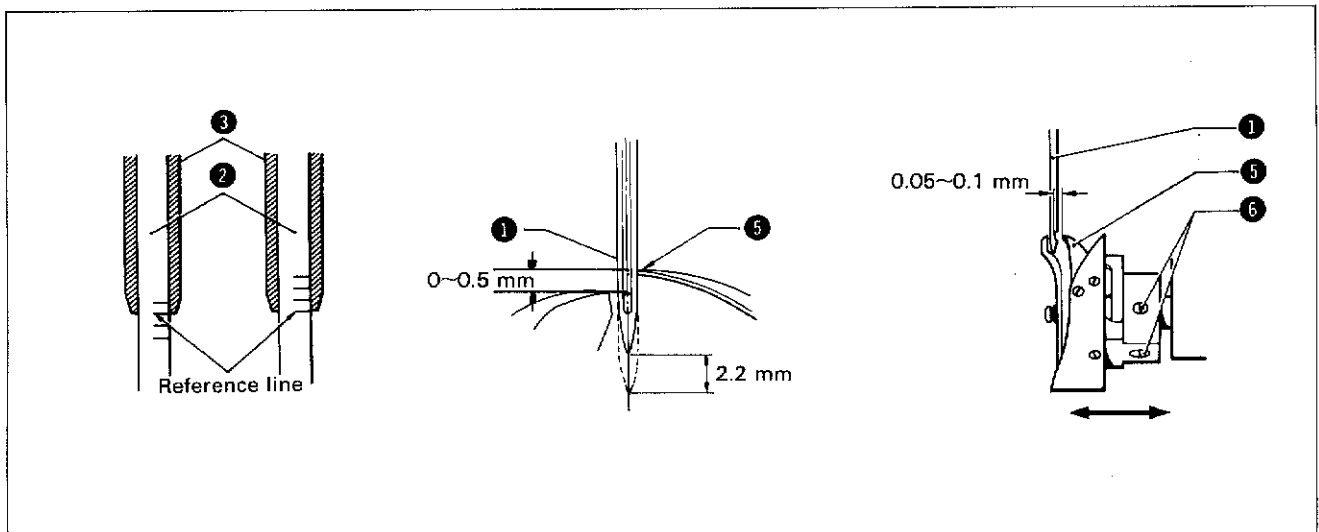

- ★ Turn the pulley slowly, and align the bottom reference line on the needle bar ② with the bottom of the needle bar bushing ③. With the needle bar in this position, check that the rotary hook point ⑤ is aligned with the needle center ① and that the needle ① to rotary hook point ⑤ gap is between 0.05 ~ 0.1 mm.
- Loosen set screw ⑥ and after aligning the rotary hook point ⑤ with the needle center ①, adjust the needle ① to rotary hook point ⑤ gap to between 0.05 ~ 0.1 mm. Firmly tighten set screw ⑥.
- * Always perform the steps for rotary hook lubrication adjustment after replacing the rotary hook.

2 Feed dog height adjustment

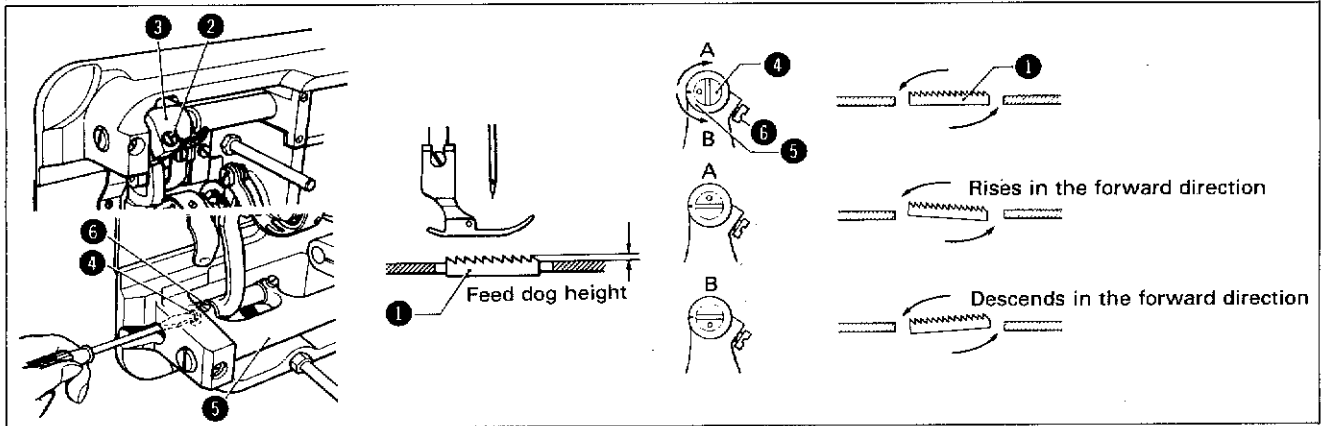

Feed dog height

1. The standard height of the feed dog for sewing thin materials is 0.8 mm, for medium materials 1.0 mm, and for thick materials 1.2 mm (when the stitch length is set to the maximum).
2. Adjust the feed dog height by loosening the screw ② when the feed dog ① is at its height position from the needle plate surface, and move the feed lifting arm ③ up and down.

Feed dog angle

1. The standard angle of the feed dog ① (horizontal to the needle plate surface when the feed dog is at its highest position) is obtained by matching the "O" mark of the feed plate shaft ④ with the notch on the feed bar arm ⑤.
 - In order to prevent packering, raise the feed dog ① in the forward direction.
 - In order to prevent the material from slipping, slant the feed dog ① in the forward direction.
 2. In order to adjust the feed dog angle, loosen the screws ⑥ and then turn the feed plate shaft ④ 90° in the directions indicated by the arrows.
- * When the feed dog angle has been adjusted, check to confirm that its height has not changed.

3 Feed timing adjustment

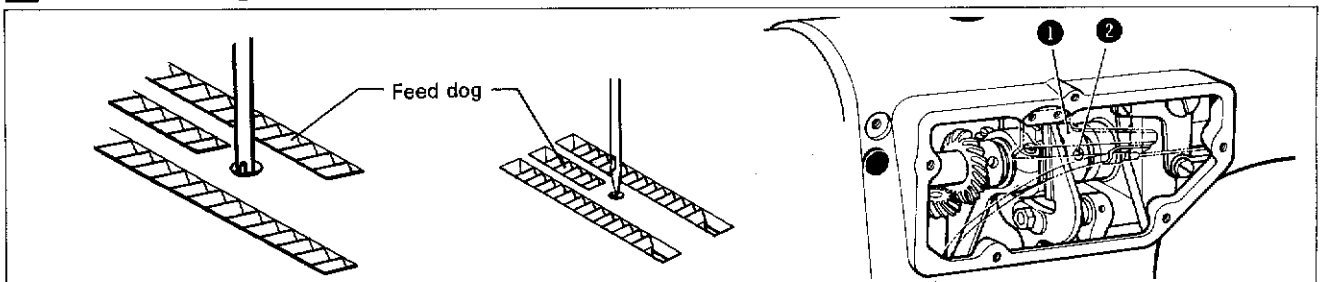

1. Turn the pulley manually; the area of the needle between the tip and the lower edge of the eye should be in alignment with the top surface of the needle plate when the feed dog completes the feed and retracts so that the tip of the feed dog is level with the top surface of the needle plate.
2. If the feed timing is not correct, loosen the set screw ② of the feed cam ① and adjust.
 - If the feed dog retracts too early, turn the feed cam slightly in the opposite direction from which the machine turns; if the feed dog retracts too late, turn the feed cam slightly in the same direction as that in which the machine turns.
3. After adjusting the timing, tighten the screw securely.

4 Presser height adjustment

- ★ The amount of presser foot rise should be 6 mm when the presser foot ① is raised by the presser bar lifter lever ②.
- Turn the presser regulating screw ③ and lower the presser bar lifter lever ②.
- Remove the cap ④ from the front cover, loosen the screw ④, and move the presser bar ⑥ up and down to adjust it.

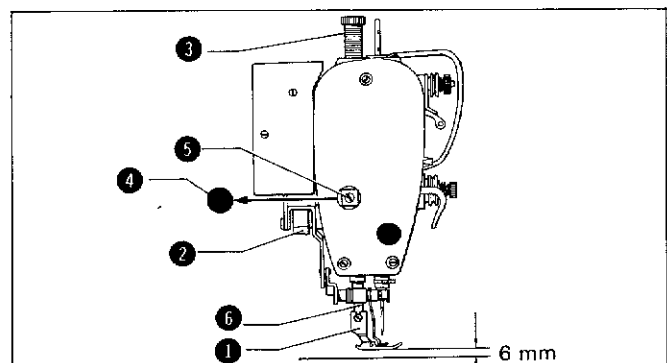

5 Synchronizer adjustment

1. Position adjustment of the thread trimmer signal

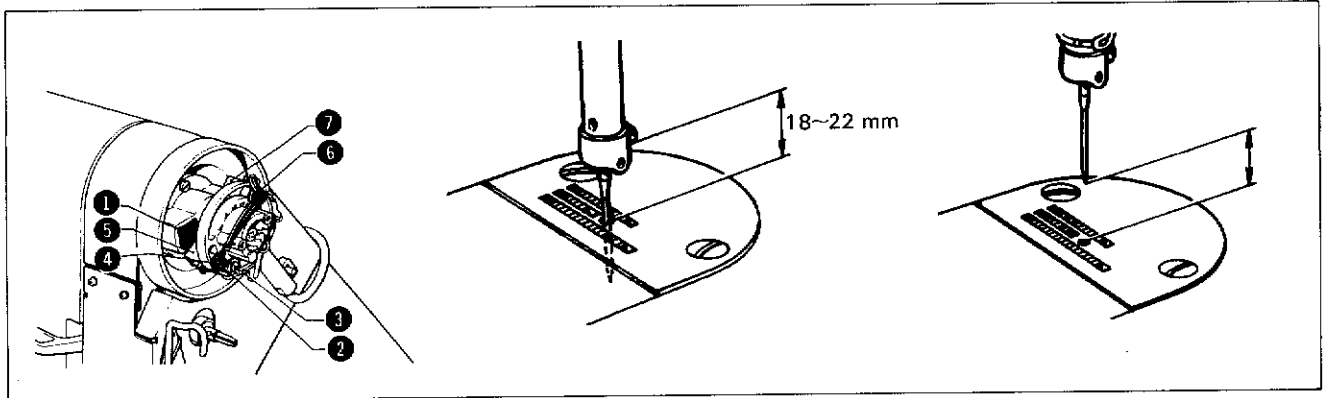

Synchronizer Adjustment (B707/B716)

1. Turn off the power of the machine.
(If the hole IC's are to be adjusted, it is important that the power first be turned off.)
 2. Remove the synchronizer cover.
 3. Rotate the pulley towards you and stop the needle 5 mm above its lowest point. The lower end of the magnet ① must be aligned at this time with the upper edge of the thread-trimmer hole IC ②.
If the lower end of the magnet ① and the upper edge of the thread-trimmer hole IC ② are not aligned, adjust by loosening the screw ③ and moving the thread-trimmer hole IC.
 4. Turn on the power and stop the machine at the needle-down position. At this time the needle bar must stop 18 ~ 22 mm above the surface of the needle plate.
If the needle bar does not stop at this position, adjust by loosening the screw ④ and moving the needle-down hole IC ⑤.
 5. Stop the machine at the needle-up position. The point of the needle must stop 9 ~ 11 mm above the needle plate for thin and medium thickness materials, and 10 ~ 12 mm above the needle plate for thick materials.
If the point of the needle does not stop at this position, adjust by loosening the screw ⑥ and moving the needle-up hole IC ⑦.
- ★ The needle bar will lower when hole IC ⑤ and hole IC ⑦ are moved in the direction of machine rotation, and rise when they are moved in the opposite direction.

Synchronizer Adjustment (B747)

1. Turn off the power of the machine.
(If the hole IC's are to be adjusted, it is important that the power first be turned off.)
 2. Remove the synchronizer cover.
 3. Rotate the pulley towards you and stop the needle 7 mm above its lowest point. The lower end of the magnet ① must be aligned at this time with the upper edge of the thread-trimmer hole IC ②.
If the lower end of the magnet ① and the upper edge of the thread-trimmer hole IC ② are not aligned, adjust by loosening the screw ③ and moving the thread-trimmer hole IC.
 4. Turn on the power and stop the machine at the needle-down position. At this time the needle bar must stop 18 ~ 22 mm above the surface of the needle plate.
If the needle bar does not stop at this position, adjust by loosening the screw ④ and moving the needle-down hole IC ⑤.
 5. Stop the machine at the needle-up position. The point of the needle must stop 9 ~ 11 mm above the needle plate for thin and medium thickness materials, and 10 ~ 12 mm above the needle plate for thick materials.
If the point of the needle does not stop at this position, adjust by loosening the screw ⑥ and moving the needle-up hole IC ⑦.
- ★ The needle bar will lower when hole IC ⑤ and hole IC ⑦ are moved in the direction of machine rotation, and rise when they are moved in the opposite direction.

6 Thread trimmer adjustment

1. Replacement of the fixed knife and movable knife

* Turn off the power.

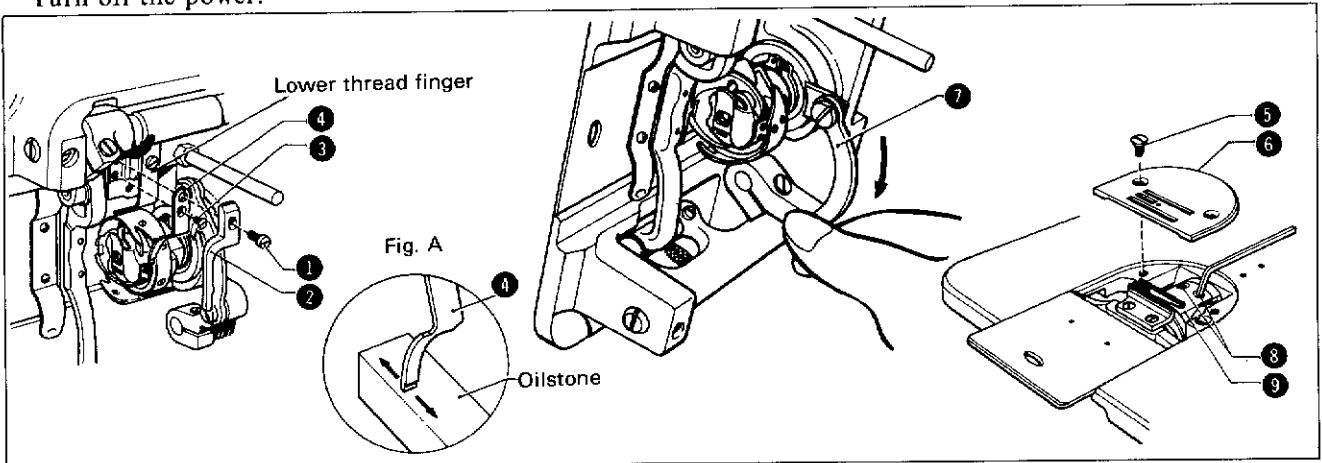

Removal of the fixed knife

- (1) Tip the machine of its side.
 - (2) Remove the screw ① and the rotary hook position bracket ②.
 - (3) Remove the screw ③ and the fixed knife ④.
- ◎ If the thread trimmer should need sharpening, sharpen the fixed knife ④ as shown in Fig. A.

Removal of the movable knife

- (1) Use the presser foot lifter lever to lift the presser foot.
- (2) Remove the screw ⑤ and the needle plate ⑥.
- (3) Turn the pulley until the needle bar is at its highest position.
- (4) Press the thread trimmer connecting bar ⑦ in the direction of the arrow and stop in at the point where the screw ⑧ can be seen.
- (5) Remove the screw ⑧ and the movable knife ⑨.

* Remove the needle plate ⑥ and the movable knife ⑨ only after the needle has been removed.

* Assemble in the reverse order of disassembly.

2. Adjustment of the fixed knife, movable knife, and lower thread finger

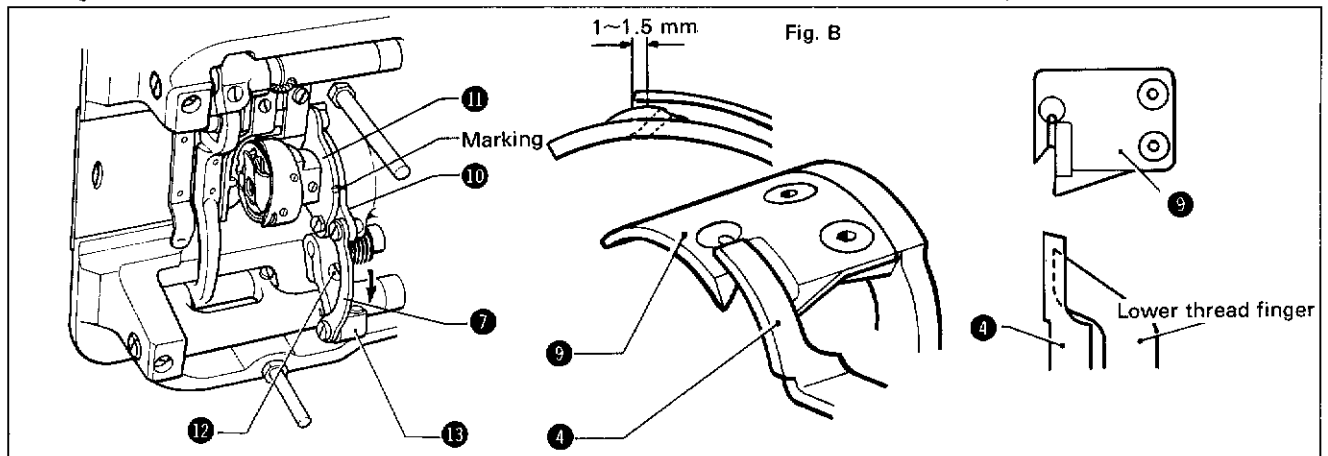

- (1) After attaching the movable knife ⑨ and the fixed knife ④, depress the thread trimmer connecting rod ⑦, and match up the marking on the movable knife holder ⑩ with the marking on the knife holder assembly ⑪. At this time the relationship between the end of the fixed knife ④ and the blade of the movable knife ⑨ must be as shown in Fig. B.

If it is not, loosen the screw ⑫ and adjust the thread trimmer lever ⑬.

* If the above adjustment cannot be performed, refer to thread trimmer timing adjustment on p.16.

* In order to maintain the distance between the lower thread finger and the rotary hook, move the lower thread finger towards the movable knife ⑨.

7 Tension release lever adjustment

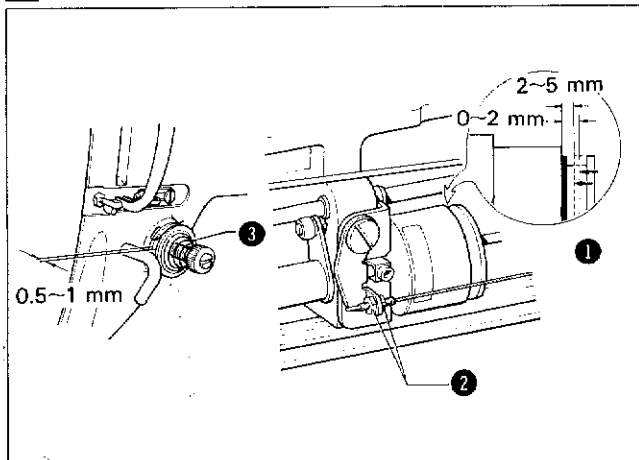

- ★ Adjust the nut ② so that the thread trimmer solenoid ① moves easily for the first 0 ~ 2 mm (tension release lever does not operate) and resists moving for the next 2 ~ 5 mm. Confirm that the tension disc ③ opens 0.5 ~ 1 mm at this time. Also, when the solenoid is not operating, confirm that the disc is firmly closed.

8 Thread wiper adjustment

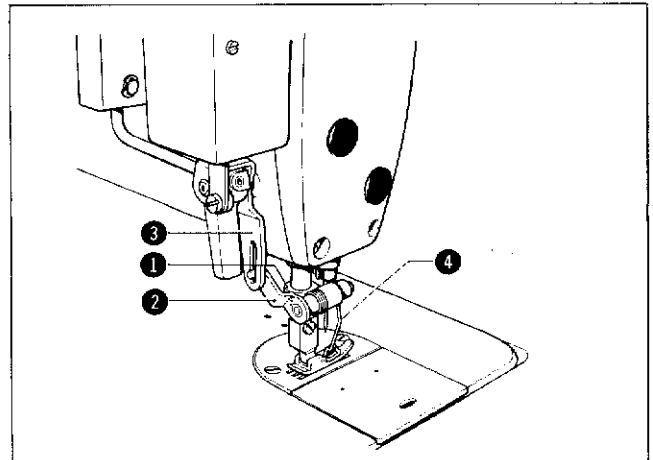

1. Attach the thread wiper bearing ① so that when the presser foot is lifted with the knee lifter, it does not come in contact with the presser bar.
2. Loosen the thread wiper lever screw and position the thread wiper lever ② so that the groove of the grooved link ③ is vertical to the bed surface.
3. Attach the thread wiper ④ so that the end of it does not come in contact with the presser foot when the presser foot is raised.

9 Automatic presser foot lifter adjustment (—900; electromagnetic type)

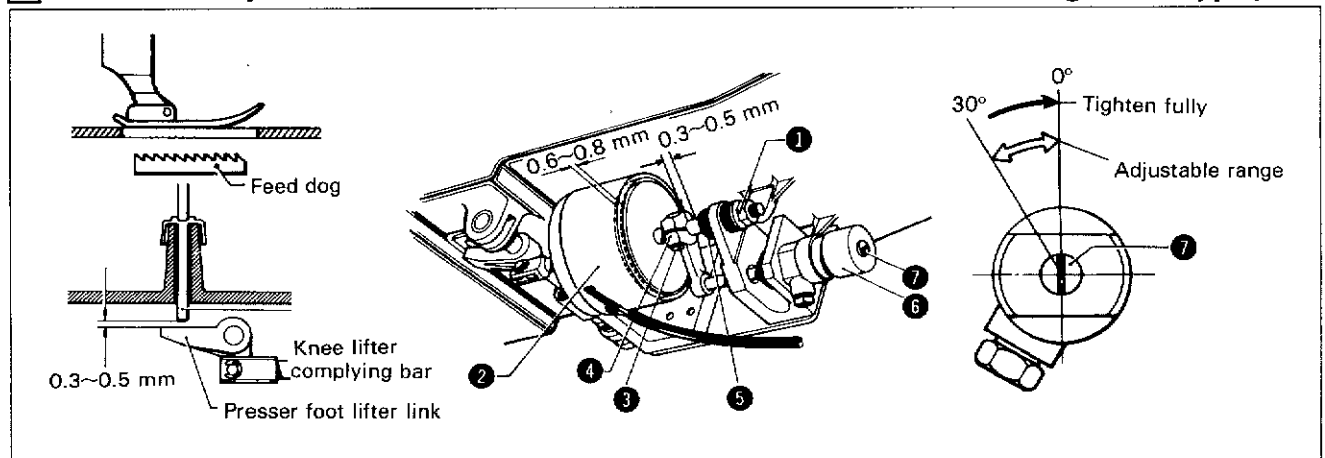

1. Adjustment of the solenoid and plunger
Adjust so that the noise (impact noise) made by the presser foot when it is lifted is small.
Turn the adjustment nut ① so that the space between the solenoid and the plunger ② is 0.6 ~ 0.8 mm.
 2. Damper support joint adjustment
Adjust so that the noise (impact noise) made by the presser foot when it comes down is small.
Set the feed dog in its lowest position.
Loosen the screw ③, and after adjusting the space between the knee lifter push bar and the presser foot lifter link to 0.3 ~ 0.5 mm, match up the damper support joint ④ with the rubber cushion ⑤.
 3. Damper adjustment
Adjust the speed the presser foot comes down with the adjustment screw ⑦ of the damper ⑥. Adjust the adjustment screw ⑦ to approximately 30° from the fully tightened position.
- * When the adjustment screw ⑦ is too tight, the presser foot will not come down (will not press against the material).
 - If this screw is too loose, the presser foot will come down too fast, thus making an impact noise and possibly damaging the material being sewn.
 - * The above procedure (1 ~ 3) is the standard adjustment; however, there may be subsequent variations due to changes in presser foot pressure and power supply voltage.

TROUBLESHOOTING GUIDE

I Machine head

Trouble	Cause	Check	Solution	Page
Needle breaks	Improper needle installation	Needle bias, height	Reinstall properly	/
	Bent needle, blunt needle tip, blocked needle hole	Needle	Replace needle	/
	Improper feed timing	Is material fed when needle is in material?	Adjust timing	21
	Improper needle to rotary hook timing	Needle bar lift stroke	Refer to "Needle and Rotary Hook Timing Adjustment"	20
		Needle bar height	Refer to "Needle and Rotary Hook Timing Adjustment"	20
		Needle to rotary hook gap	Refer to "Needle and Rotary Hook Timing Adjustment"	20
Thread breaks	Improper threading	Threading	Rethread properly	/
	Bent needle, blunt needle tip, blocked needle hole	Needle	Replace needle	/
	Improper needle installation	Needle bias, height	Reinstall properly	/
	Excessive upper thread tension	Upper thread tension	Adjust tension	/
	Excessive lower thread tension	Lower thread tension	Adjust tension	/
	Loose upper thread	Thread take-up spring stroke	Adjust take-up spring	/
Thread frays	Burr in thread path		Remove with sandpaper	/
	Blunt needle tip		Replace needle	/

Trouble	Cause	Check	Solution	Page
Skipped stitches	Improper needle installation	Needle bias, height	Reinstall properly	/
	Bent needle or blunt needle tip	Needle bias, height	Replace needle	/
	Improper threading	Threading	Rethread properly	/
	Improper needle to rotary hook timing	Needle bar lift stroke	Refer to "Needle and Rotary Hook Timing Adjustment"	20
		Needle lift length	Refer to "Needle and Rotary Hook Timing Adjustment"	20
		Needle to rotary hook gap	Refer to "Needle and Rotary Hook Timing Adjustment"	20
	Upper thread left at needle is too short and doesn't remain in material		Adjust pretension	/
	Bobbin idles and bobbin thread is too short to rise during thread trimming	Bobbin case idler prevention screw	Replace idler prevention spring	/
	Thread take-up spring is too weak to lift bobbin thread	Thread take-up spring tension	Adjust thread take-up spring	/
	Upper thread does not tighten	Upper thread tension too weak		Increase upper thread tension
Excessive upper thread tension			Decrease bobbin thread tension	/
Lower thread does not tighten	Excessive upper thread tension		Decrease upper thread tension	/
	Lower thread tension too weak		Increase bobbin thread tension	/

Trouble	Cause	Check	Solution	Page
Thread trimmer misses	Movable and fixed knives do not meet	Check alignment of thread trimmer holder and thread trimmer holder presser index marks	Align movable and fixed knives	23
a. neither upper or lower thread is cut	Movable and fixed knife blades are burred or abraded	Movable and fixed knife blades	Replace movable and fixed knives	23
	Movable and fixed knife does not move	Is thread trimmer signal output?	Check electrical circuitry	
	Improper needle installation	Needle bias	Reinstall properly	
b. upper thread is not cut	Stitch skips at last stitch and upper thread trimmer does not catch upper thread	Thread take-up spring stroke	Adjust thread take-up spring	
	Movable and fixed knives do not meet	Check alignment of thread trimmer holder and thread trimmer holder presser index marks	Align movable and fixed knives	23
	Poor cutting by movable and fixed knives	Movable and fixed knife blades	Replace movable and fixed knives	23
c. lower thread is not cut	Movable and fixed knives do not meet	Check alignment of thread trimmer holder and thread trimmer holder presser index marks	Align movable and fixed knives	23
	Insufficient tension disc opening	Tension disc opening	Adjust tension release lever	24
Upper thread casts off at sewing start	Excessive pretension		Adjust pulley tension	
	Thread too thick for needle hole		Needle size	
	Needle upper stop position is too high and thread left by thread take-up	Thread take-up height when machine is in needle upper stop position	Delay needle up stop	22

Trouble	Cause	Check	Solution	Page
Thread cutter does not move	Thread trimmer signal not output		Check circuits	/
	Upper thread too long		Check and adjust pretension	/
Thread wiper does not pull upper thread up from material	Excessive material and presser foot resistance		Replace with presser foot with rear gap	/
	Early timing; pulls off before tension disc closes		Adjust operating time	/
	Thread wiper operating time too short		Adjust operating time	/
Thread wiper strikes needle and does not return	Thread wiper operating time too long		Adjust operating time	/
	Automatic presser foot rises too quickly		Adjust operating time of presser foot	/

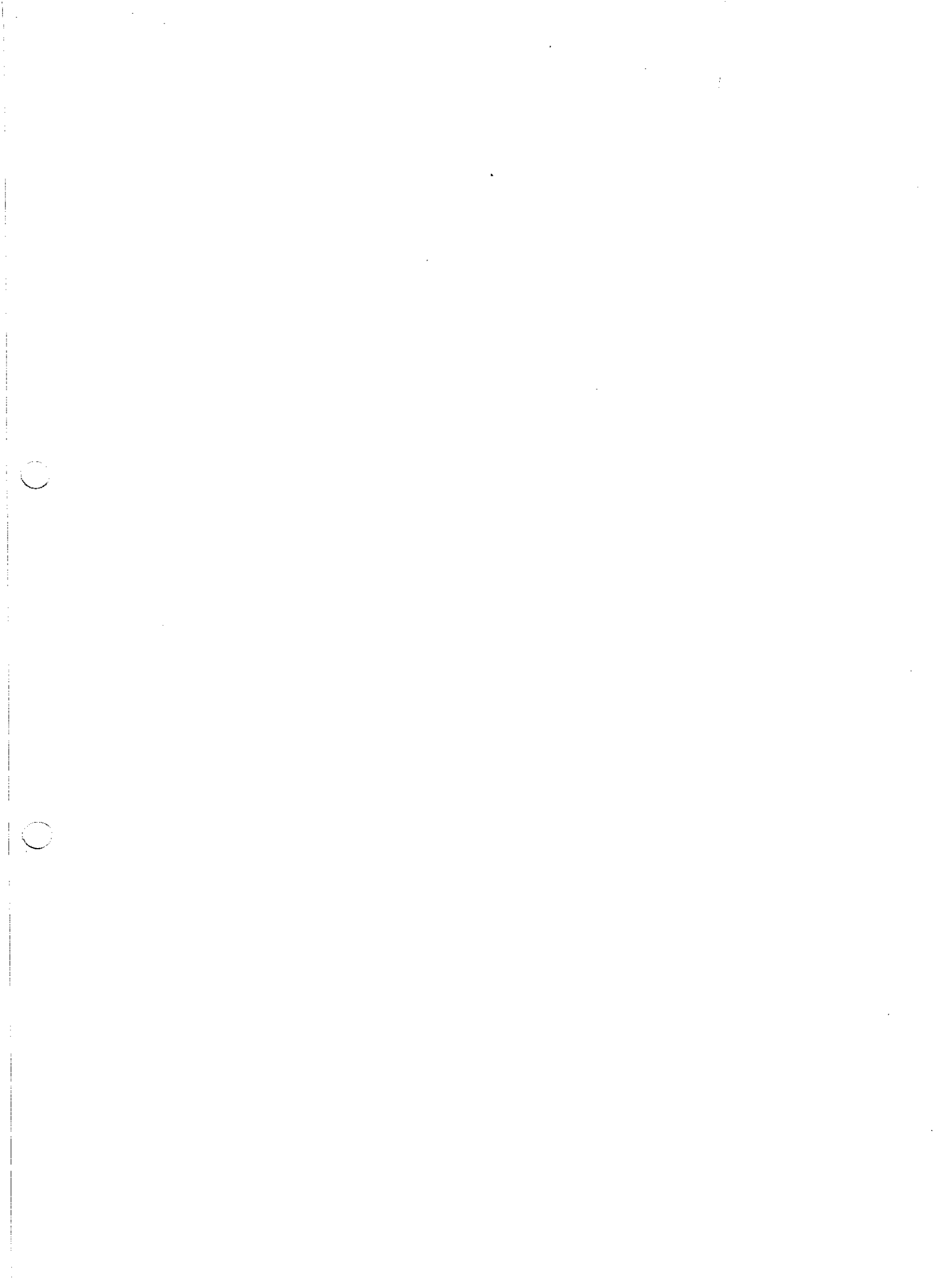



BROTHER INDUSTRIES, LTD.

HEAD OFFICE: No. 35, 9-CHOME,
HORITA-DORI, MIZUHO-KU, NAGOYA, JAPAN 467
CABLE: BROTHER NAGOYA,
TELEX: BROTHER 4473696J & J59743