

brother

# AUTOMATIC BUTTONHOLE SEWING UNIT

BAS-510

INSTRUCTION MANUAL

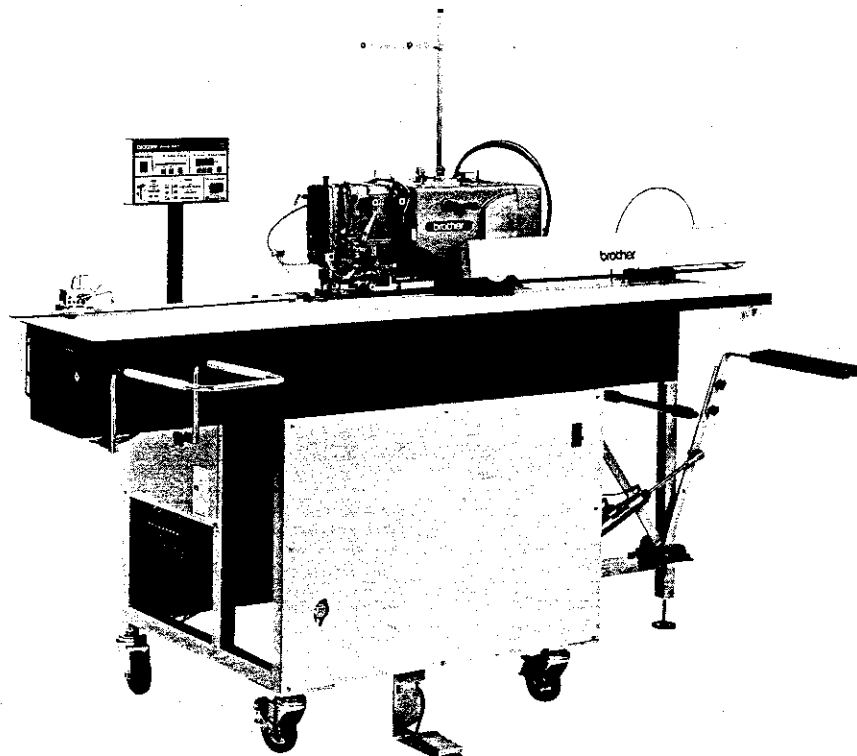

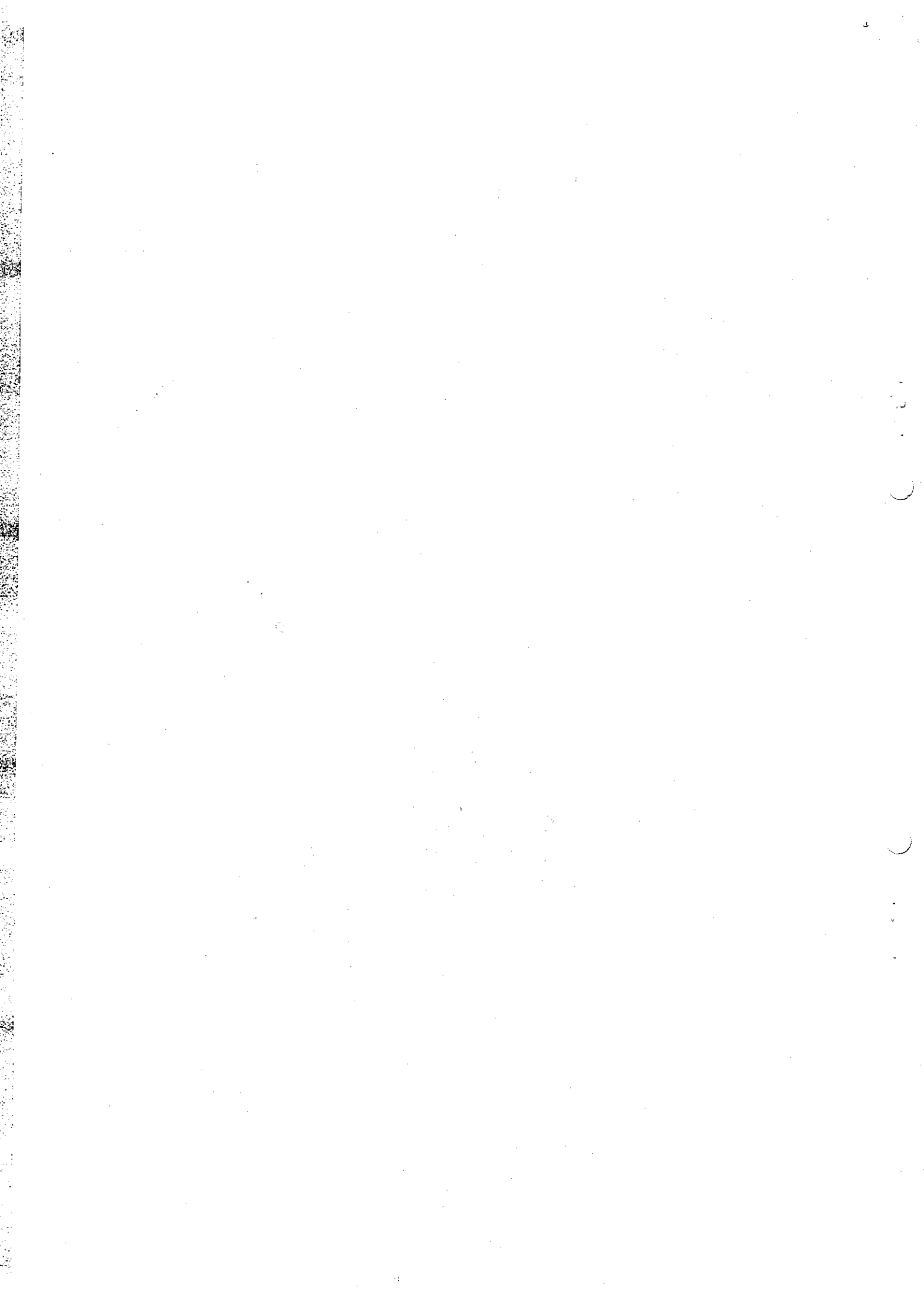

## **BAS-510 FEATURES**

The BAS-510 automatic buttonhole sewing machine is a high performance, automatic machine combining a buttonhole sewing machine, material feed mechanism, and a stacker. The BAS-510 makes front placket buttonhole sewing on dresses, shirts, men's dress shirts, and other garments more accurate and efficient with the added touch of fashion needed in today's garment market.

A proprietary microcomputer control system developed by Brother makes it as easy to match button positions after the first and second buttonholes to original designs as it is to set an equal interval between buttonholes. In addition, up to ten different sewing patterns can be stored in memory. The material feed table moves from 150 to 600 (1150) mm horizontally with smooth, precise positioning assured by DC servo motor drive. A standard stacker enables easy overlap work, and makes it easier for a single operator to maintain multiple machines.

## Table of Contents

	<b>MAIN PART NAMES</b> .....	1
	<b>OPERATION PANEL DESCRIPTION</b> .....	2
	<b>SET-UP</b> .....	4
1	Positioning the machine .....	4
2	Foot switch installation .....	4
3	Spool stand installation .....	4
5	Stacker height adjustment .....	4
6	Air hose and plug connections .....	5
7	Bodice support .....	5
8	One-pedal adapter installation .....	6
	<b>CORRECT OPERATION</b> .....	7
1	Air pressure adjustment .....	7
2	Threading .....	7
3	Air flow adjustment .....	8
4	Setting the workpiece .....	9
5	Margin-to-seam width adjustment .....	10
	<b>OPERATION</b> .....	11
1	Standard operations .....	11
2	Determining dimension A, the number of holes, and the distance .....	12
	Sewing buttonholes at even intervals .....	12
	Sewing buttonholes at irregular intervals .....	13
	Men's and ladies' garment selection .....	15
	Programming errors .....	15
3	Trial sewing .....	15
4	Sewing .....	16
	Using the emergency stop function .....	16
	Needle thread breakage .....	17
5	Setting the thread counter .....	19
6	Using the stacker .....	20
7	Checking clamp movement and stacker operation .....	21
8	Clamp L adjustment .....	22
9	Leading edge guide timing adjustment .....	23
10	Sewing counter .....	24
11	Sewing long garments .....	24
12	Adjusting the air vents .....	25
13	Tilting the machine head .....	26
14	To change the buttonhole size .....	27
15	Other precautions .....	31

# MAIN PART NAMES

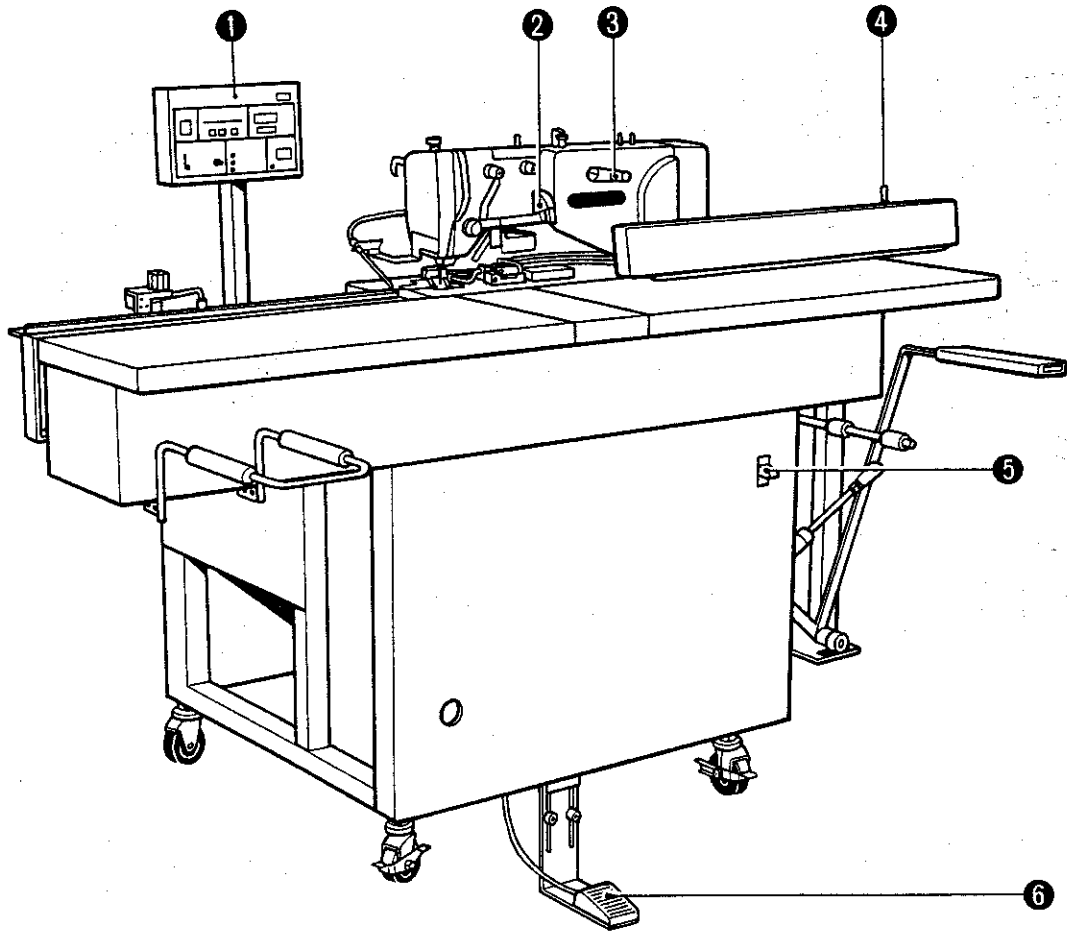

- ① Operation panel
- ② Start switch
- ③ Handle
- ④ Stacker switch
- ⑤ Power switch
- ⑥ Foot switch

Model	LH4-B805A
Buttonhole length (knife width)	11-22mm
Dimension A	45-429mm
B	7-20mm
C	150-600 (1150) mm
D	25-600mm
Buttonhole number	2-10
Pattern storage capacity	10 patterns
Workpiece feed	Clamp feed
Presser bar stroke	10mm
Needle	S Y 1906

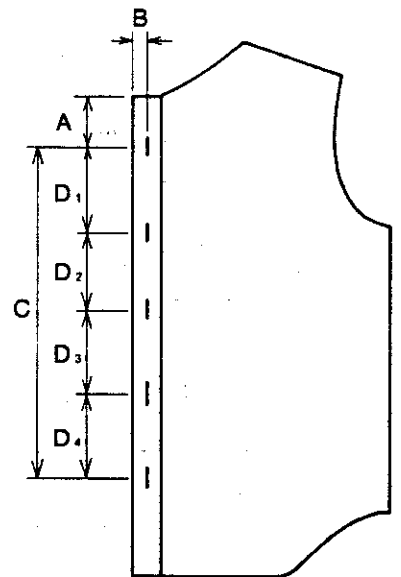

※ Refer to the instruction manual for sewing machine model LH4-B815 for machine operation.

# OPERATION PANEL DESCRIPTION

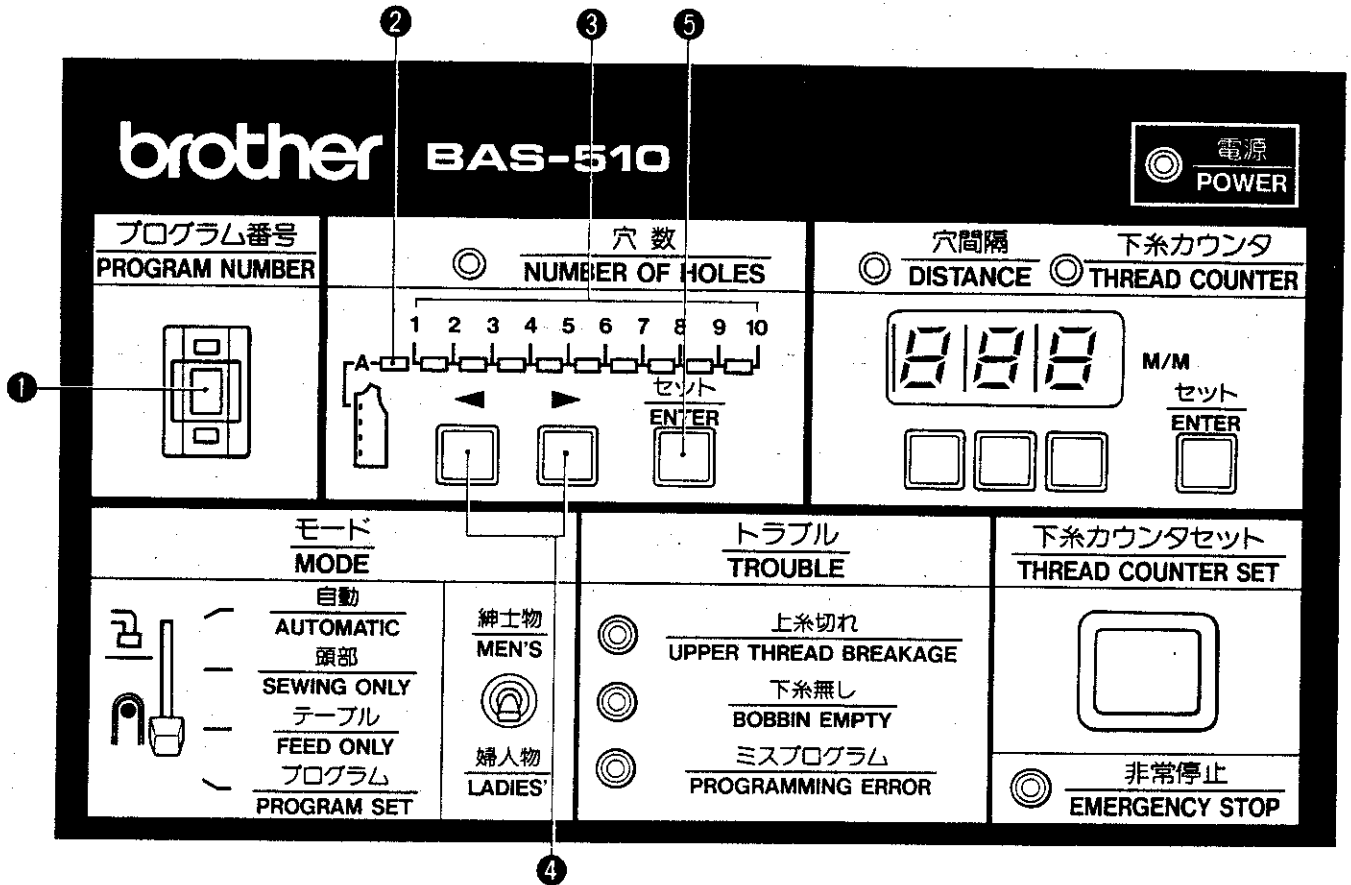

## 1. PROGRAM NUMBER

Program number (0-9) selectors

- ★ Used to select one of ten sewing pattern programs stored in memory. Program number 0 is used for even interval buttonholes.
- ★ Press the lower button to decrease the program number (0-9), the upper button to increase the program number.

## 2. Dimension A indicator

Dimension A is programmable while the indicator is on.

## 3. NUMBER OF HOLES indicators

Indicates the number of holes (number of feeds); the current feed position is indicated with a blinking indicator (number of holes, distance).

## 4. Arrow buttons

Used to increase or decrease the number of holes, to shift the clamp position, and to restart after an emergency stop.

## 5. ENTER

Used to enter the number of holes at uneven intervals.

brother BAS-510

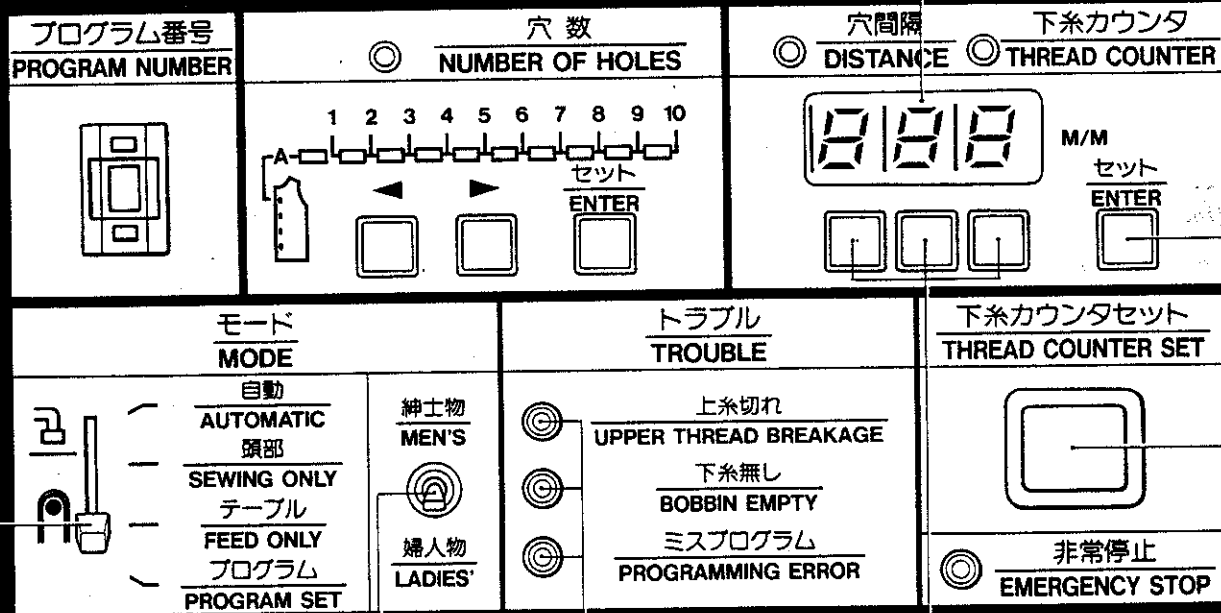

6. LED selector buttons  
Used to change the number in the LED display (distance, thread counter).
7. LED display  
Displays the buttonhole interval (distance), the thread counter, and the number of workpieces.
8. ENTER  
Used when entering the buttonhole interval for irregular buttonholes, and when setting the bobbin thread counter.
9. THREAD COUNTER SET, EMERGENCY STOP switch  
Used to change the bobbin thread counter, to activate and cancel an emergency stop, and to clear the workpiece counter.
10. TROUBLE indicators  
The respective indicator lights when the upper thread breaks, the bobbin is empty, or there is a programming error.
11. MODE selector
 

AUTOMATIC	Set here for automatic sewing.
SEWING ONLY	Set here for trial sewing or manual sewing.
FEED ONLY	Set here to operate the clamp only.
PROGRAM SET	Set here when programming a pattern.
12. Garment type selector
 

MEN'S	Set here when sewing front plackets on men's garments.
LADIES'	Set here when sewing front plackets on women's garments.

※ The machine cannot be operated until the power is turned on and the start switch is pressed. (See page 11 for standard operation.)

## SET-UP

### 1 Positioning the machine

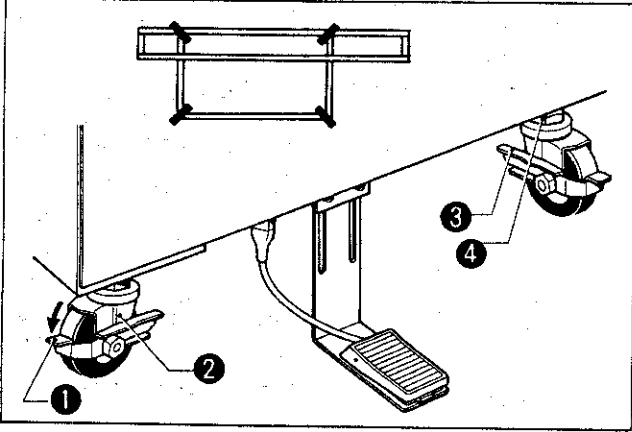

1. After deciding where the power table is to be installed, lower lever 1 to lock caster 2. Lower lever 3 to disengage the lock and roll the caster.
2. To adjust the table height, loosen nut 4, and turn caster 2,  
\* Be sure to firmly retighten nut 4 after adjusting the height.
3. Set the casters 2 at an angle to the table.  
(See the figure at left.)

### 2 Foot switch installation

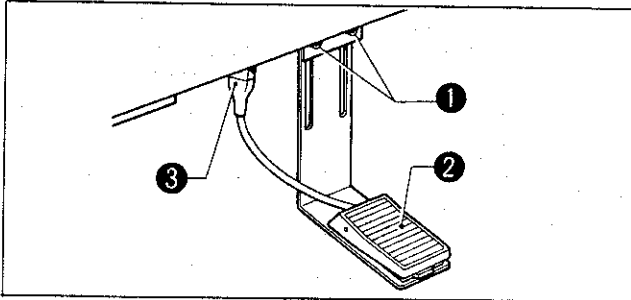

1. Loosen Allen bolt 1, and lower foot switch 2 to the floor.
2. Tighten Allen bolt 1.
3. Connect connector 3.

### 3 Spool stand installation

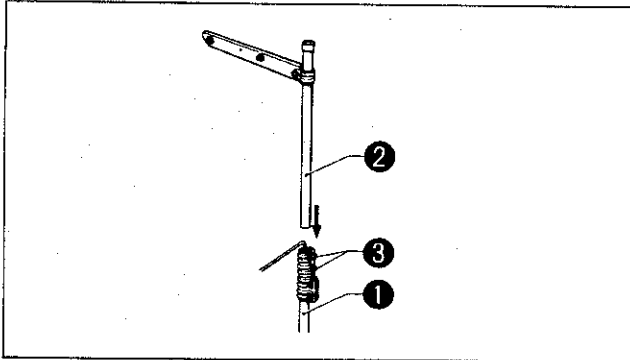

1. Insert column pipe 2 into column pipe D 1, and then tighten the two screws 3.

### 4 Stacker height adjustment

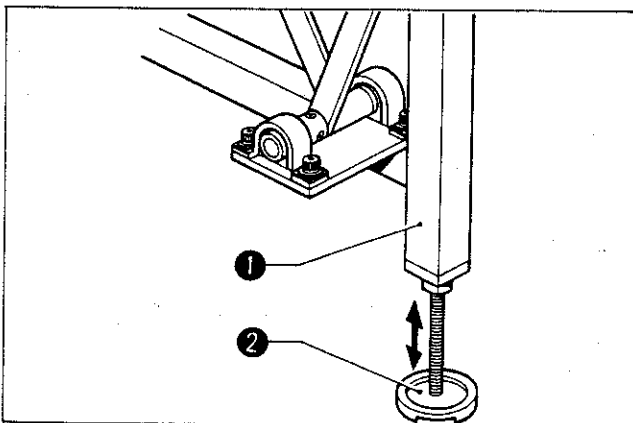

1. Adjust level seat 2 so that the stacker 1 does not tilt.



## 5 Air hose and plug connections

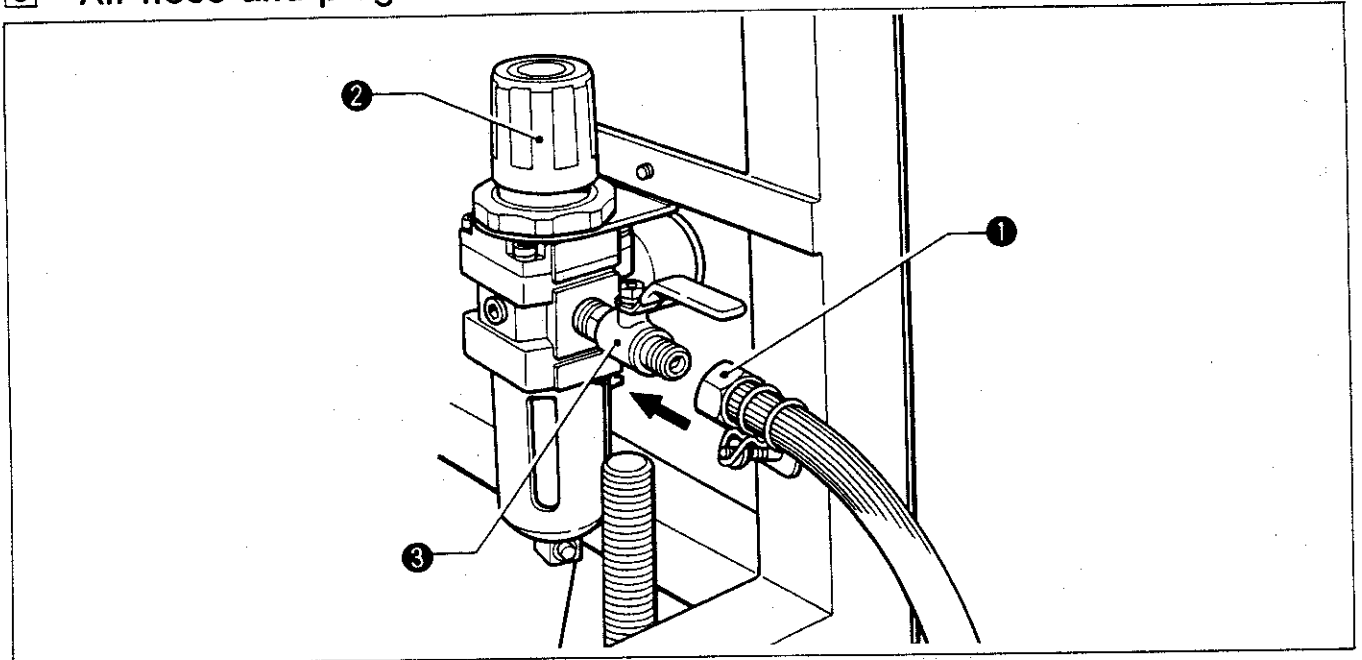

1. Connect hose ① to connector ③ of air unit assembly ②.

## 6 Bodice support

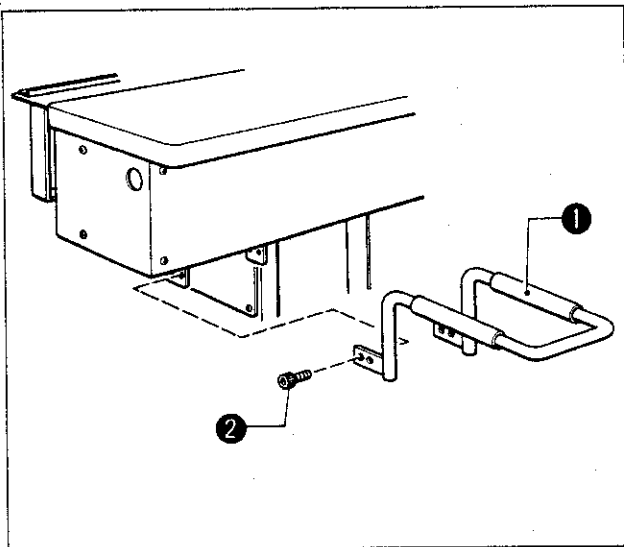

1. Install the bodice support ① with four Allen bolts ②.

## 7 One-pedal adapter installation

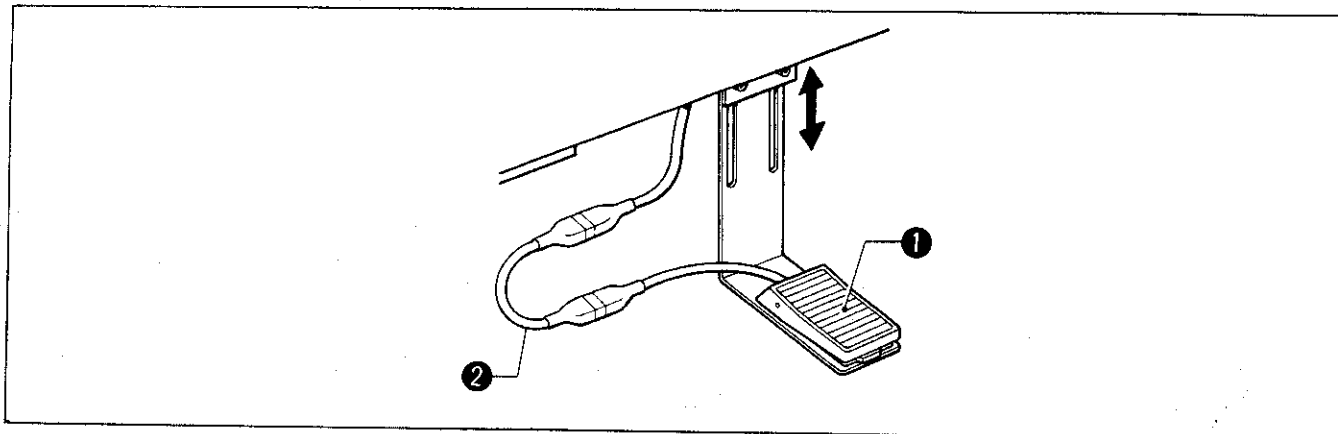

- ※ Disconnect the 4P connector of foot switch ①, and connect the one-pedal adapter ② included in the accessories.
  - ※ The foot switch and start switch will now have the same functions.
1. When the MODE selector is at FEED ONLY
    - (1) When the foot switch is pressed once, clamps L and R will descend and clamp the work piece, and the stacker will move to the material clamp position.
    - (2) Continue pressing the foot switch to move the clamp and check stacker operation.
  2. When the MODE selector is at SEWING ONLY
    - (1) When the foot switch is pressed and then released quickly, the material clamp will descend. The material clamp will rise when the foot switch is pressed lightly again.
    - (2) When the foot switch is pressed and held, the material clamp will descend, and a buttonhole will be sewn.
  3. When the MODE selector is at AUTOMATIC

The programmed buttonhole pattern will be sewn automatically when the foot switch is pressed.
- ※ Both the foot switch and the start switch will function as above.
  - ※ Remember that the material cannot be reset (except in 2-(1) above). Be sure to position the material before pressing the foot switch or start switch.
  - ※ When the MODE selector is at AUTOMATIC the programmed pattern will be sewn automatically when the foot switch is pressed. Be careful not to press the foot switch by mistake.

## CORRECT OPERATION

- ★ When the machine is purchased and at one month after operation begins the capacitor used to back-up the memory must be recharged. To do this, turn the power on and do not use the machine for 15 minutes. If the PROGRAMMING ERROR indicator lights, the display goes out, or the program contents are not properly displayed, refer to page 31.

### 1 Air pressure adjustment

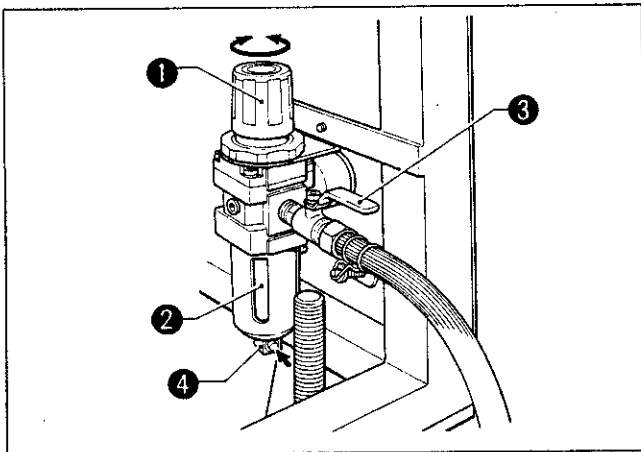

1. Use with the air pressure set at 5 kg/cm<sup>2</sup>. To adjust, lift handle 1.
2. If water collects inside the bottle 2, close cock 3, and press drain cock 4 in the direction of the arrow to drain the water.  
※ When cock 3 is opened, the stacker will rise.  
Be careful.

### 2 Threading

- ★ Thread the machine as shown in the figure below.

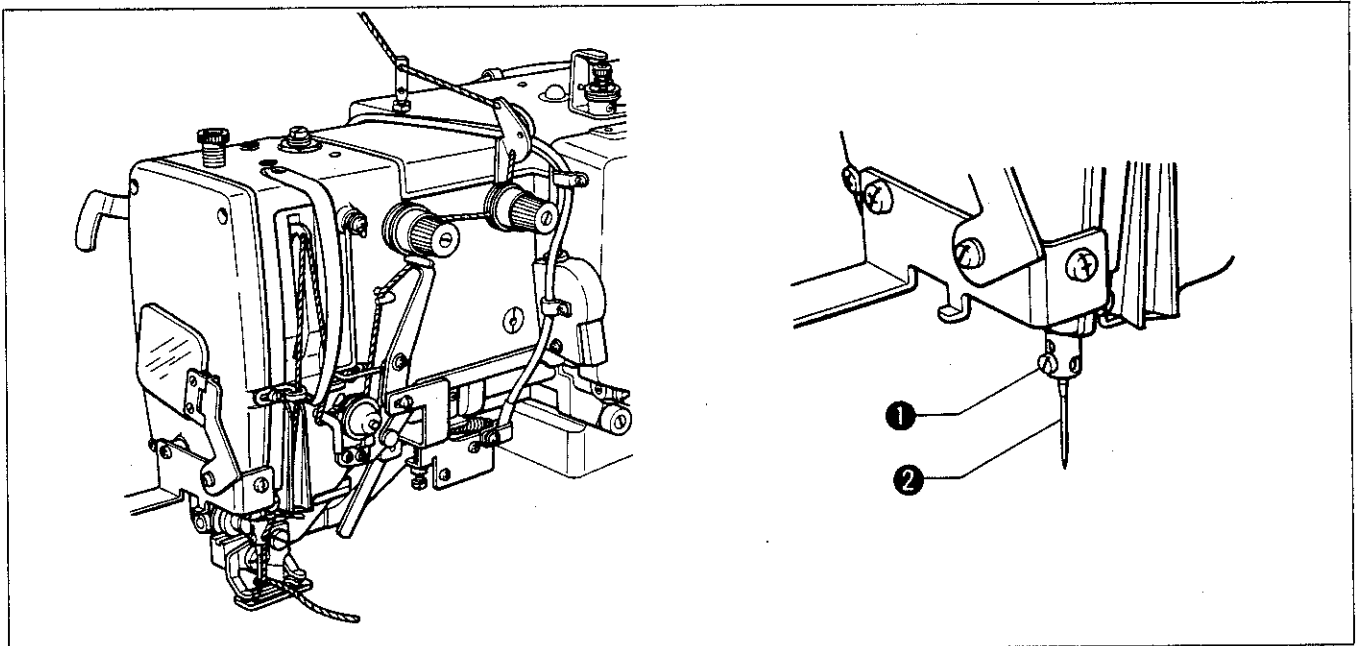

- ★ To replace the needle, loosen screw 1 in the figure above and replace the needle 2.

### 3 Air flow adjustment

Turn cocks ① and ② to adjust the air flow.

Soft materials ..... Decrease the air flow.

Stiff materials ..... Increase the air flow.

Strong curves ..... Increase the air flow.

※ 1. Adjust the air flow so that it strikes the top of the brush.

Raising the brush height will improve the material feed, but if the brush is too high, it will be hard to set the material in place. About 2-3 mm above the surface is usually best.

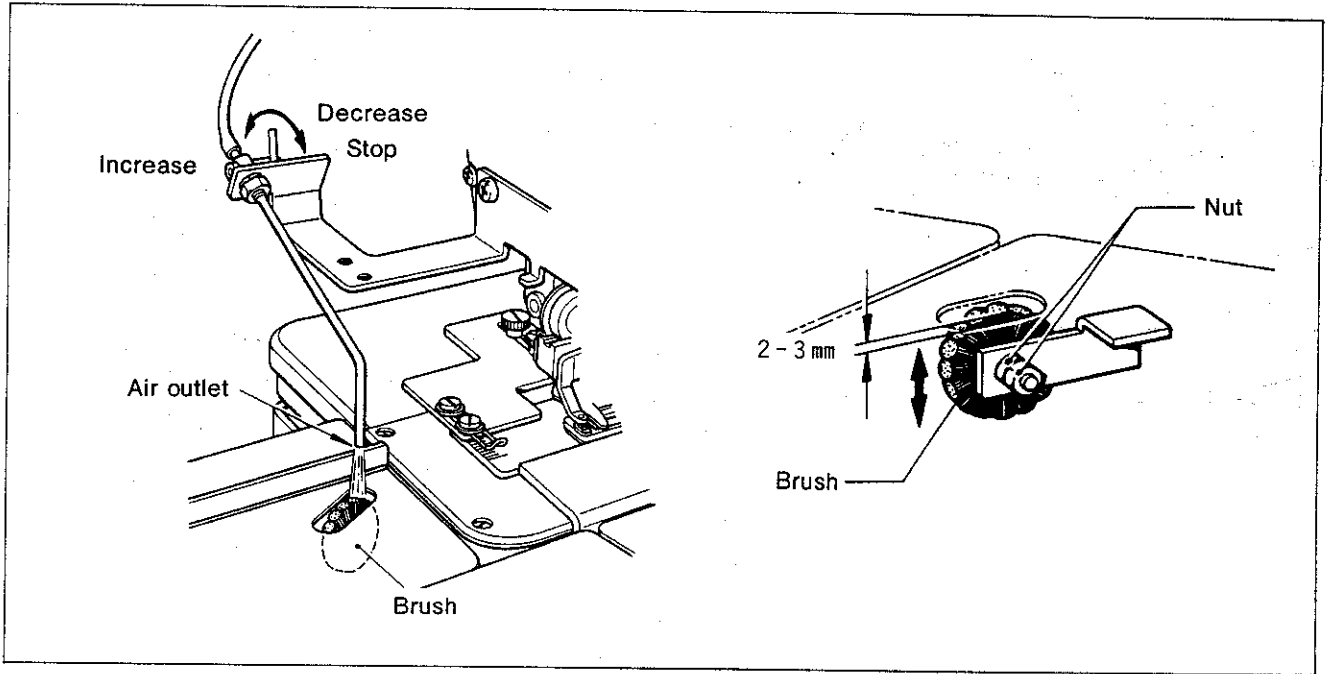

#### 4 Setting the workpiece

- ★ The buttonhole length is set to approximately 16 mm at the factory. (The cutter length is approximately 12.7 mm.)
- ★ Set the free material scale for the clamp to 17 mm.  
Turn the power switch on. The material clamp will rise.  
Set the men's/women's garment type selector ① as desired.  
Press the start switch. Clamp L ② will move left, and will then return to the programmed position.  
See page 12 for programming guidelines.  
(Men's garments)..... Set the selector to MEN'S.

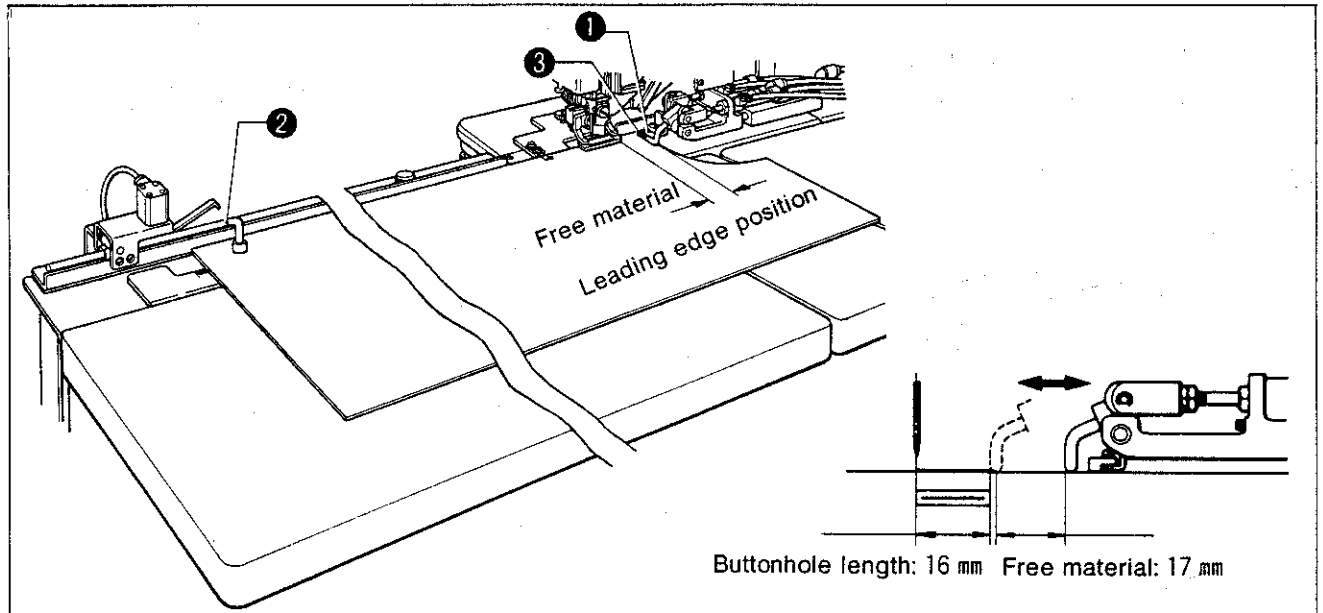

Align the material with the leading edge guide ①, and then press the foot switch. Clamps L ② and R ③ will hold the material. If clamp adjustment is required, refer to the below.  
(Ladies' garments)..... Set the selector to LADIES'.

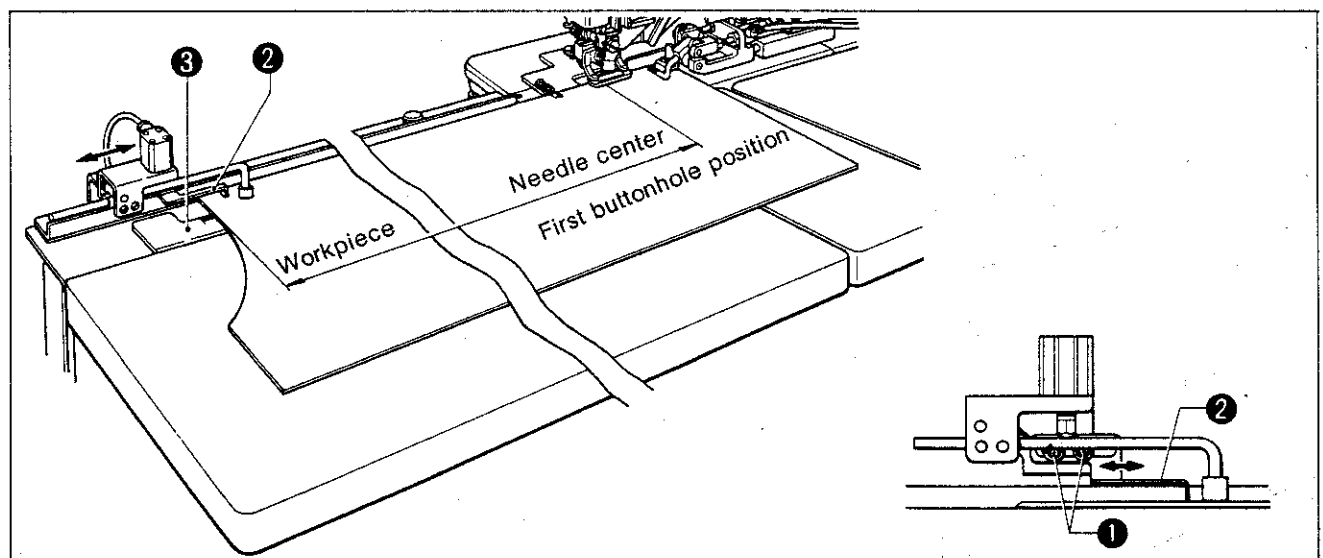

1. Position the women's garment guide ② with the two set screws ① so that it is at the first buttonhole position.
2. Align the leading edge of women's garment guide ② with the index on left clamp presser A ③. (Adjust it to dimension A.)

## 6 Margin-to-seam width adjustment

- ★ The margin-to-seam width should be adjusted so that the distance from the center of the buttonhole to the material edge is from 7 to 20 mm.
- ★ Turn the power switch off before making the adjustment.

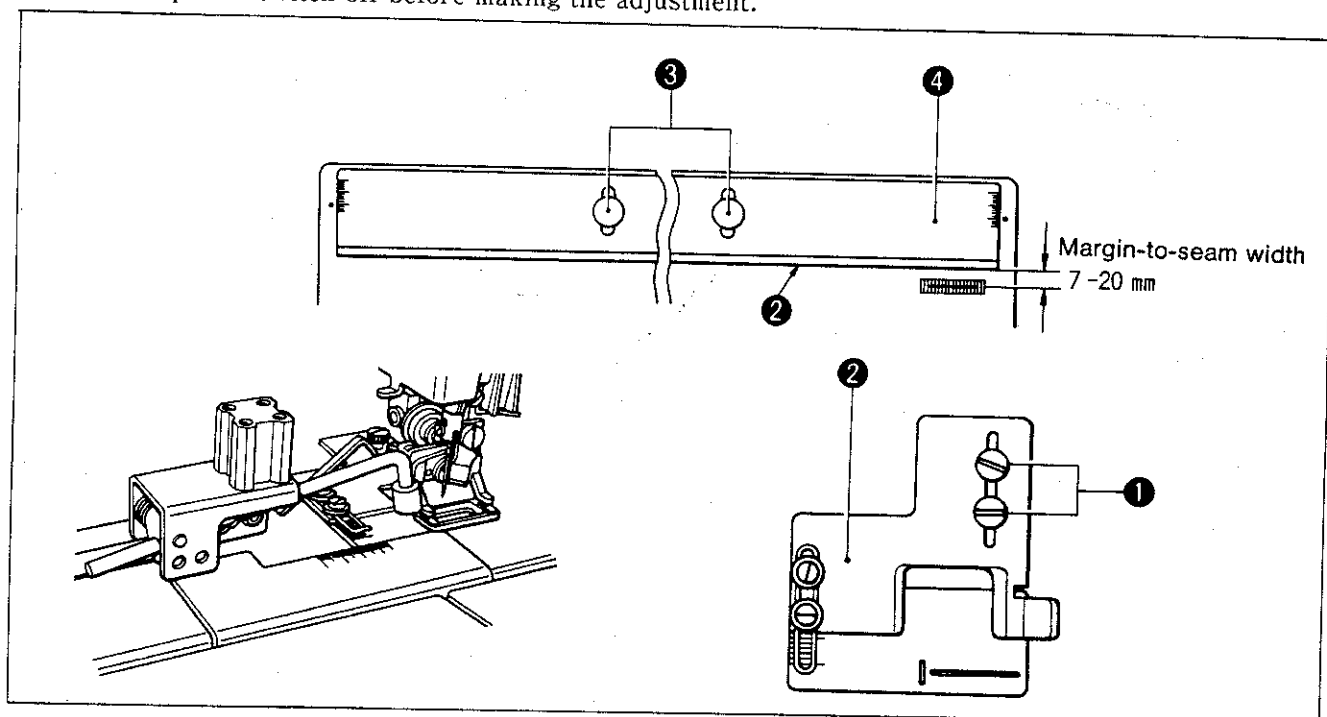

1. Loosen two screws ①, and align the edge of vertical ruler ② with the index on the needle plate.
2. Loosen two screws ③, and move and move bodice guide ④ to align it with the red index on the bodice guide ruler.

- ★ If the bodice on men's dress shirts is buckled

If the bodice is buckled, the margin-to-seam width (dimension A in the figure) will not be even. Adjust as follows.

- ※ Turn the power switch off.

Slide bodice guide ④ dimension B plus 1 mm in the direction of the arrow, and secure the bodice guide aligned with the red index on the ruler.

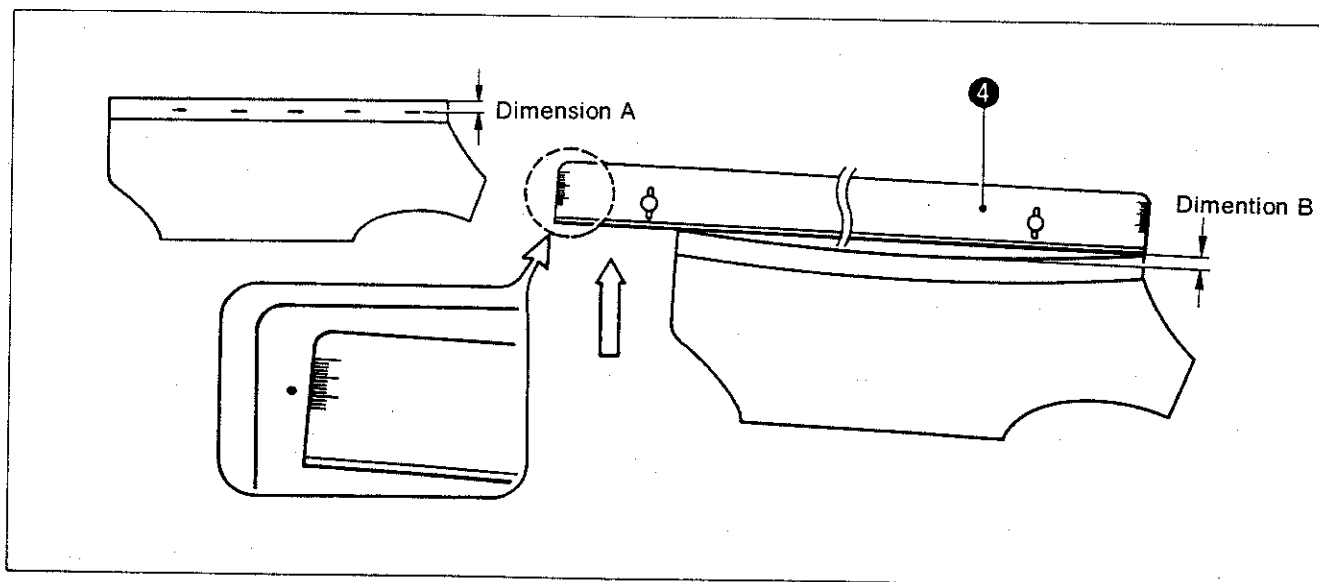

# OPERATION

## 1 Standard operations

★ Turn the power switch ① on.

Set garment type selector ⑬ according to whether it is a men's or women's garment that will be sewn.  
(See page 14.)

★ Press start switch ②. Move the clamp to the start position (material set position).

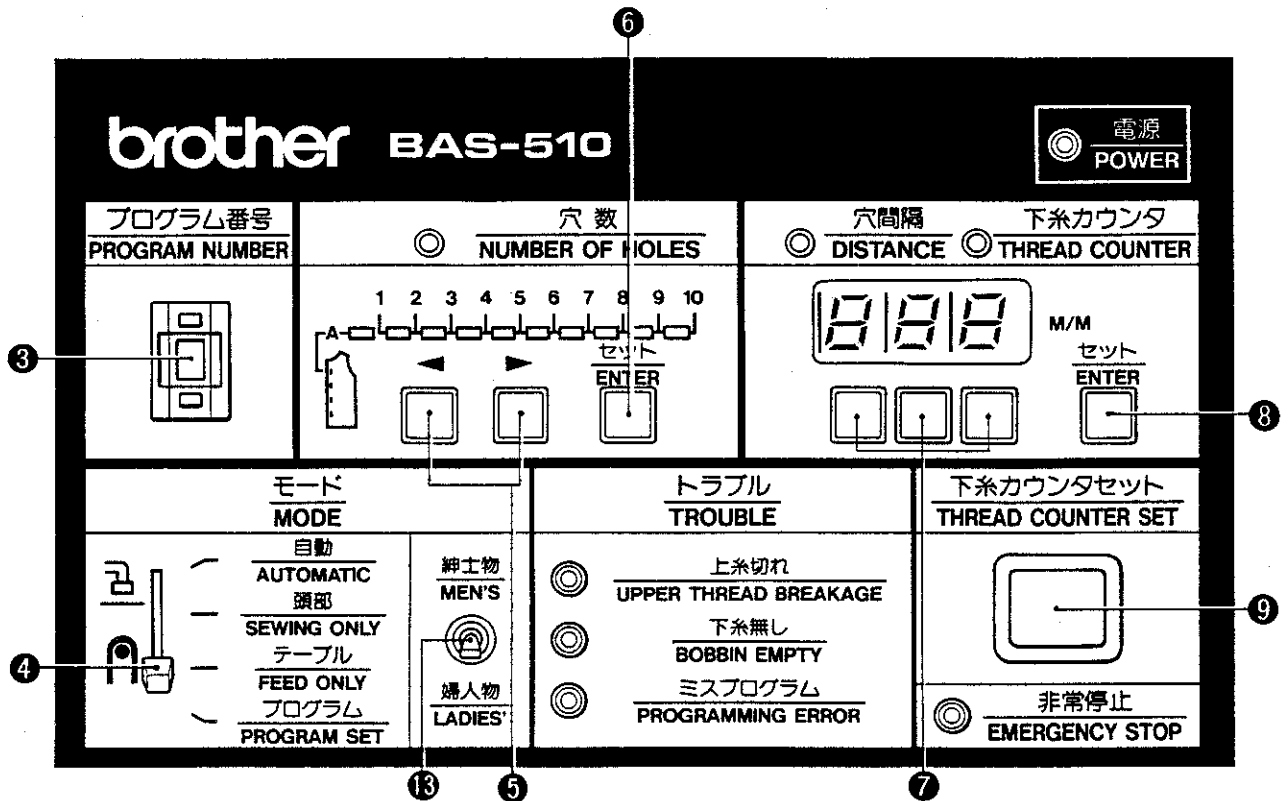
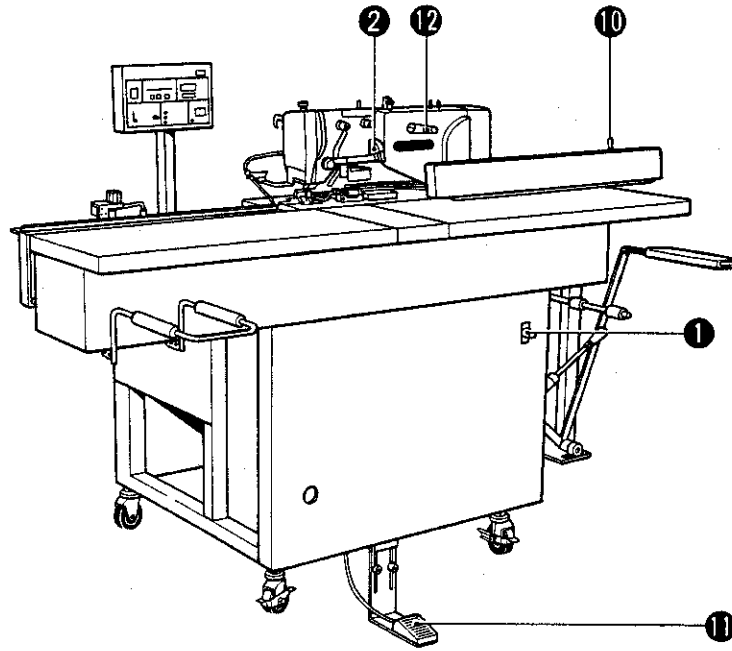

## 2 Determining dimension A, the number of holes, and the distance

### [Sewing buttonholes at even intervals]

- (1) Press program number selector ③ so that the program number is 0. (Numbers 1-9 are for irregular buttonhole spacings.)
- (2) Set MODE selector ④ to PROGRAM SET.  
The dimension A indicator will light and the distance indicator will blink.
- (3) Use switches ⑦ to set dimension A.  
※ If dimension A is not to be changed, skip step (3).
- (4) Press ENTER ⑧ to fix dimension A.  
The NUMBER OF HOLES and DISTANCE indicator will blink.
- (5) Press arrow switches ⑤ to enter the number of holes.  
Press ▶ ⑤ to increase, ◀ ⑤ to decrease the number.  
The number of buttonholes will be indicated by the number that becomes on above the display. The number of indicators that light shows the number of feed intervals.
- (6) Press switches ⑦ to set the feed.
- (7) Set the MODE selector ④ to any position other than PROGRAM SET.  
The program will not be stored until the MODE selector is switched from PROGRAM SET.

Ex. 1. Press switch ⑦ in step (3) above to set dimension A to 100, and then press ENTER ⑧.  
(Dimension A has now been set at 100 mm.)

Press ◀ ▶ ⑤ to set the number of holes to 4. (Four buttonholes will be sewn.)

Press switch ⑦ so the LED display shows 150. (This sets the distance between buttonholes to 150 mm.)

※ If the PROGRAMMING ERROR indicator lights during program entry, see p. 15.

※ Dimension A must be set to between 60 and 399 mm.

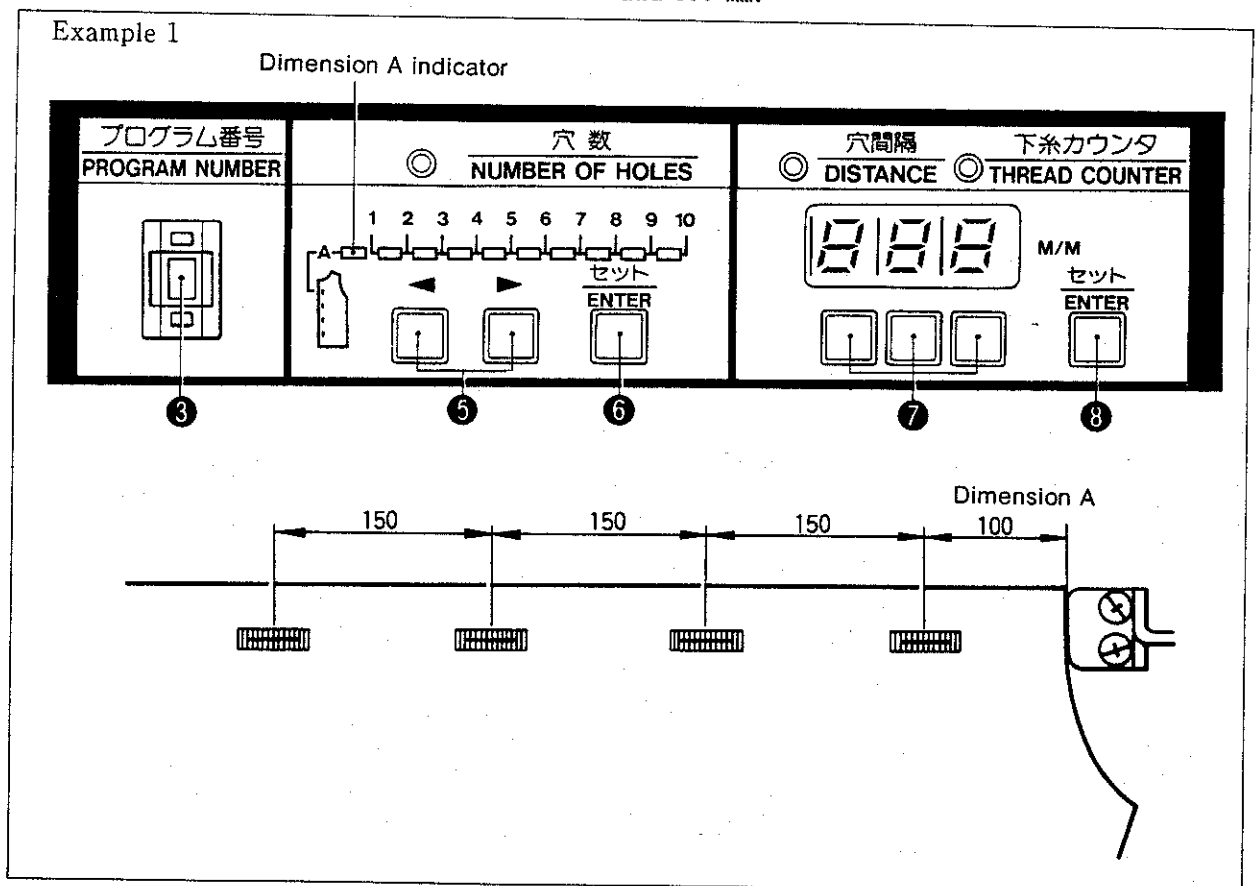



### [Sewing buttonholes at irregular intervals]

- (1) Press program number selector **3** so that the program number is any number from 1-9. (Number 0 is for even buttonhole spacings.)
- (2) Set the MODE selector **4** to PROGRAM SET.  
The dimension A indicator will light and the distance indicator will blink.
- (3) Use switches **7** to set dimension A.
- (4) Press ENTER **8** to store dimension A.  
The NUMBER OF HOLES indicator will blink.
- (5) Press arrow switches **5** to enter the number of holes.
- (6) Press **▶ 5** to increase, **◀ 5** to decrease the number.  
The number of buttonholes will be indicated by the number that becomes on above the display. The number of indicators that light shows the number of feed intervals.
- (7) Press ENTER **6** to store the number of holes.  
The NUMBER OF HOLES indicator will light steady, and the DISTANCE indicator and the indicator for the gap between holes 1-2 will blink.
- (8) The feed distance for the interval indicated by the blinking indicator can now be set.
- (9) Press switch **7** to set the feed distance for interval 1-2.
- (10) Press ENTER **8**. (The position of the second buttonhole is now set.)
- (11) Press **▶ 5** so that the indicator for interval 2-3 blinks.
- (12) Press switch **7** to set the feed distance for interval 2-3.
- (13) Press ENTER **8**. (The position of the third buttonhole is now set.)
- (14) Press **▶ 5** so that the indicator for interval 3-4 blinks.
- (15) Press switch **7** to set the feed distance for interval 3-4.
- (16) Press ENTER **8**. (The position of the fourth buttonhole is now set.)  
※ Repeat steps (13) - (15) for each of the button intervals.
- (17) Set the MODE selector **4** to any position other than PROGRAM SET.

The program will not be stored until the MODE selector is switched from PROGRAM SET.

Ex. 2. Press switch **7** to set dimension A to 100, and then press ENTER **8**.

Press **5** to set the number of holes to 4, and press ENTER **6**.

Press switch **7** so the LED display shows 80, and press ENTER **8**. Press **5**. Press switch **7** so the LED display shows 150, and press ENTER **8**. Press **5**. Press switch **7** so the LED display shows 150, and press ENTER **8**.

※ If the PROGRAMMING ERROR indicator lights during program entry, see p. 15.

※ Dimension A must be set to between 60 and 399 mm.

Example 2

Dimension A indicator

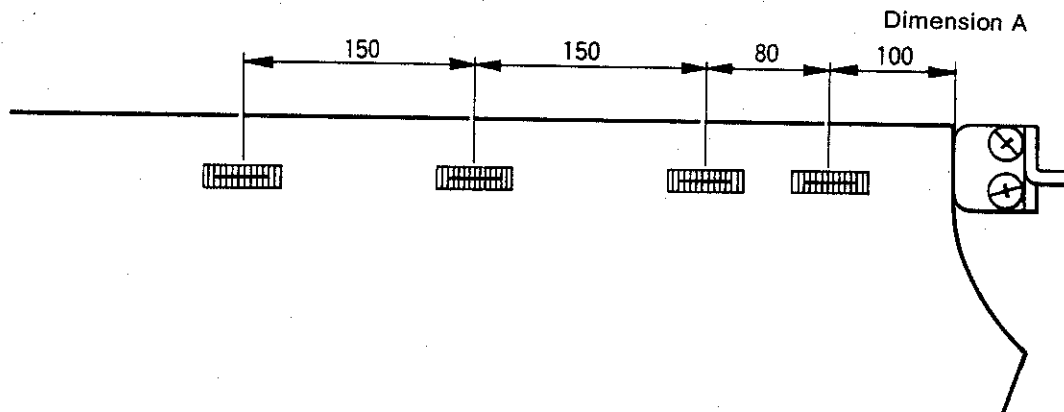
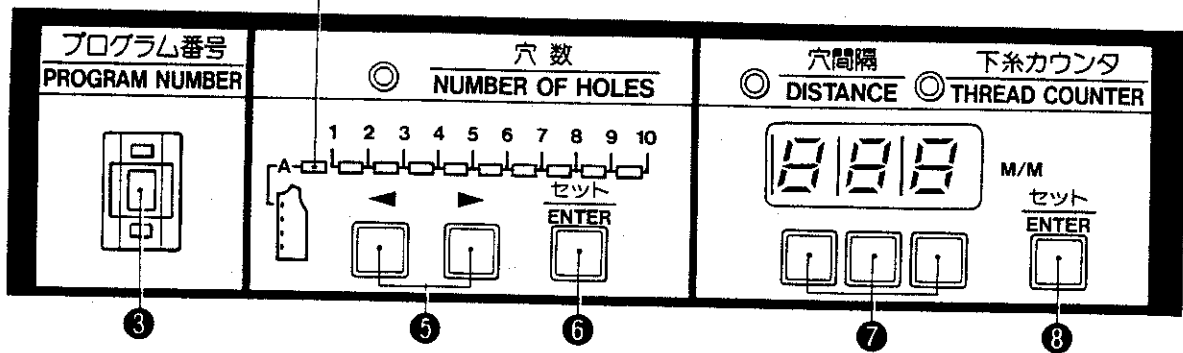

『Men's and ladies' garment selection』

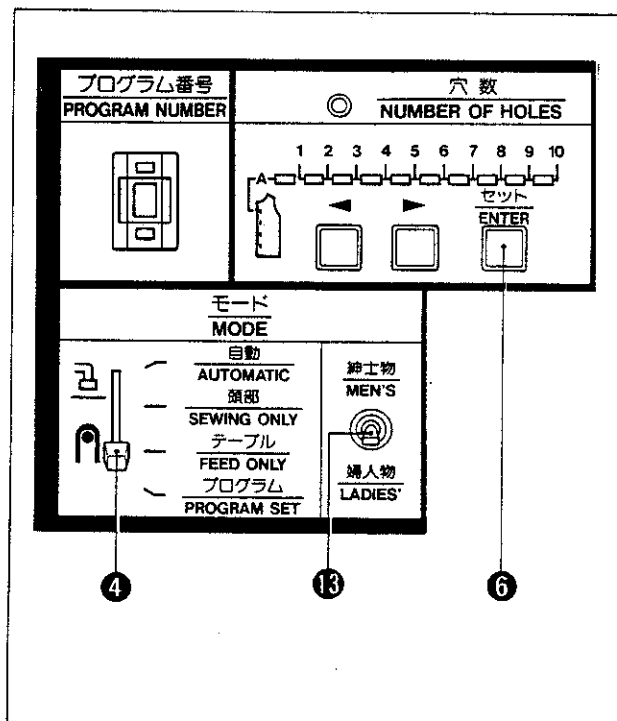

- (1) Set the garment type selector 13 to either MEN'S or LADIES' according to the type of garment being sewn.
- (2) Set the MODE selector 4 to PROGRAM SET.
- (3) Enter the program.
  - ※ When sewing men's garments, the leading edge guide will descend.
  - ※ When sewing women's garments, the leading edge guide will rise.
  - ※ To change an entered program from a men's to a ladies' garment or vice versa, set MODE selector 4 to PROGRAM SET, and then press ENTER 6 twice.
  - ※ The format of a programmed pattern cannot be changed by simply resetting the garment type selector 1 (MEN'S, LADIES') in the AUTOMATIC or FEED ONLY modes.

### [Programming errors]

- ★ When the DISTANCE indicator is on, the feed distance will be displayed in the LED display in millimeters. When the indicator is blinking, the feed length can be changed.
- ★ The total feed length must be from 150 mm to 600 (1150) mm. A PROGRAMMING ERROR will be indicated if the total feed length is not within this range, and sewing will not be possible. The program must be re-entered.

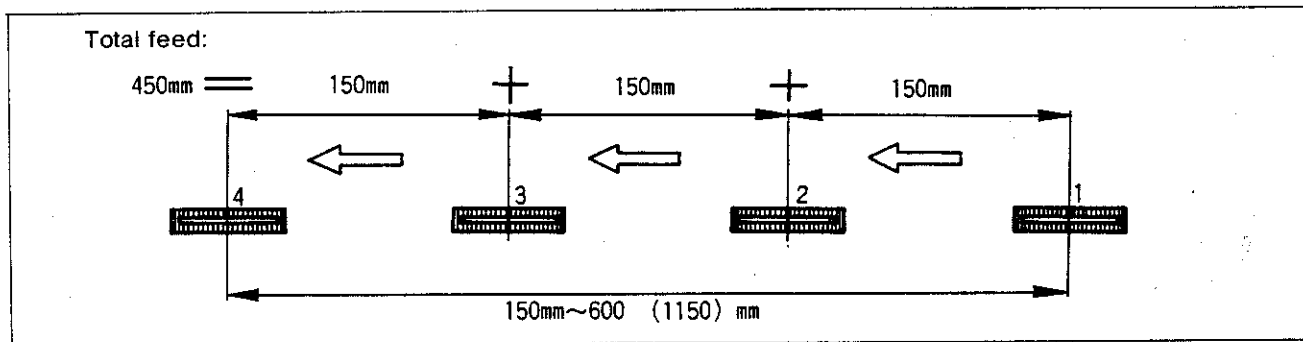

### 3 Trial sewing

1. Set the MODE selector ④ to SEWING ONLY.
2. Press ► ⑤ to move the clamp to an easier sewing position.
  - ※ To return to the home position, set MODE selector ④ to any position other than SEWING ONLY.
3. Insert a piece of material under the material clamp, and press start switch ②. One buttonhole will be sewn. The material can be clamped if the foot switch is pressed at this time.

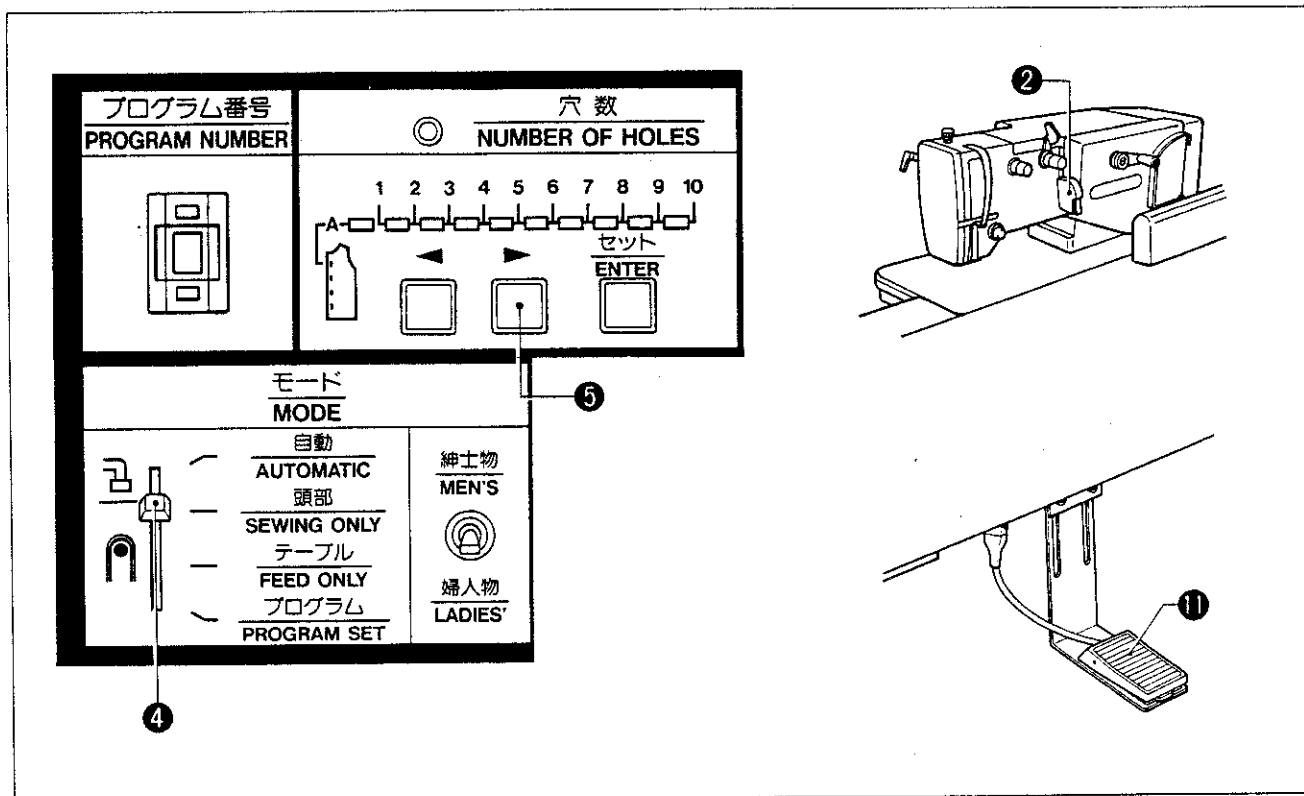

## 4 Sewing

1. Set MODE selector ④ to AUTOMATIC.  
Align the material with the material positioning guide and bodice guide, and under the material clamp.  
Press the foot switch ① to set the material.
2. Press the start switch ②.  
The programmed buttonhole(s) will be sewn automatically.

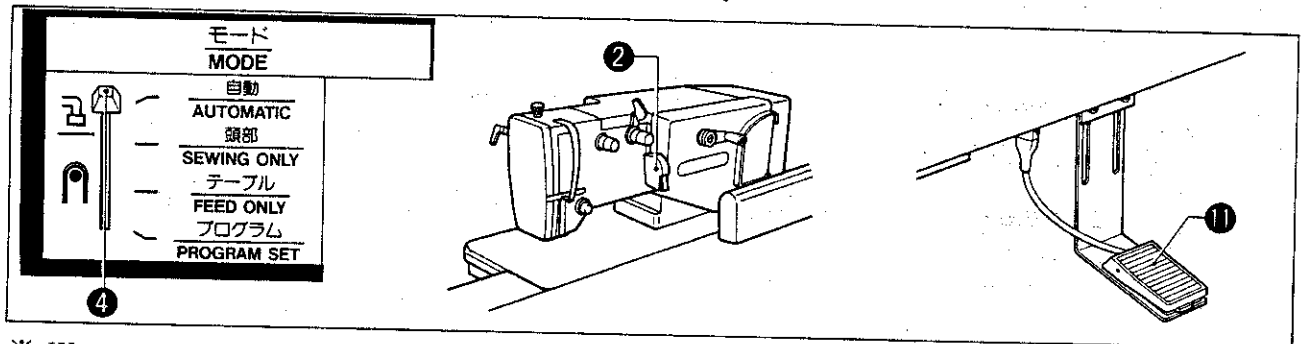

### ※ Women's garments

When sewing women's garments, set the material in the position opposite to that used when sewing men's garments. Note also that the standard position of the buttonhole at dimension A is different for men's and women's garments.

For standard garments, the women's garment guide should be set to 60 mm. (Dimension A can be adjusted from 40 to 199 mm.)

### 〔Using the emergency stop function〕

- ★ When the EMERGENCY STOP ⑨ button is pressed:  
The machine will stop after completion of the present cycle if sewing is in progress, or after clamp movement has stopped if the clamp is moving when the EMERGENCY STOP button is pressed, and the indicator will blink.
- ★ To restart
  - a. If the machine was stopped while the clamp was moving.  
To restart sewing from the stop position, press switch ⑨. The EMERGENCY STOP indicator will go out. Now press the start switch ②, and the remaining part of the program will be sewn automatically.
  - b. If the machine was stopped while sewing was in progress  
Press switch ⑨ to restart sewing from the buttonhole position, turn the EMERGENCY STOP indicator out, press one of the arrow switches ▶ ⑤, and then press the start switch ②.  
The remaining part of the program will be completed automatically.

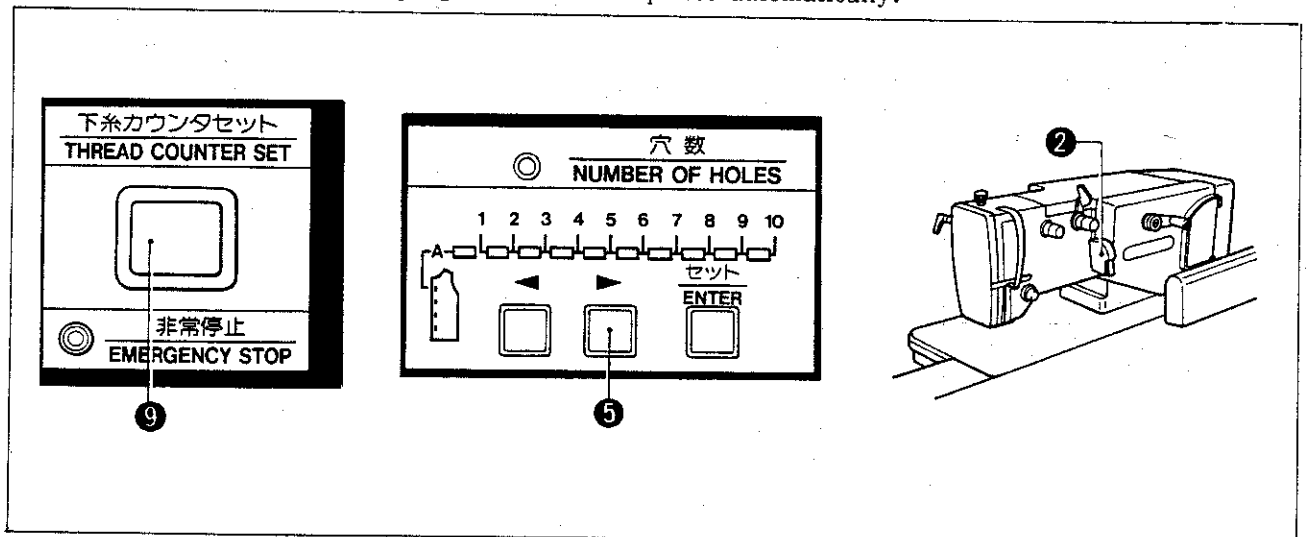

### 『Needle thread breakage』

- ★ If the needle thread breaks while sewing, the UPPER THREAD BREAKAGE indicator will light, the EMERGENCY STOP indicator will blink, and the machine will stop automatically after one cycle is completed
- ★ To restart
  - (1) Thread the needle thread.
  - (2) Press switch ⑨. The UPPER THREAD BREAKAGE and EMERGENCY STOP indicators will go out.
  - (3) a. To restart sewing from the beginning of the buttonhole at which sewing stopped, press the start switch ②. After resewing the buttonhole, the rest of the program will be sewn automatically.
  - b. To restart sewing from the point at which the thread broke in the same buttonhole, turn handle ⑫ to some point before where the thread broke and press the start switch ②. After sewing the buttonhole where the thread broke, the rest of the program will be sewn automatically.
  - c. To restart sewing from the buttonhole following that at which the thread broke, press ▶ ⑤ and press the start switch ②. The rest of the pattern will be sewn automatically after feeding to the next buttonhole position.
- ★ If thread breakage occurs during AUTOMATIC sewing and the EMERGENCY STOP indicator lights due to an unprogrammed stop

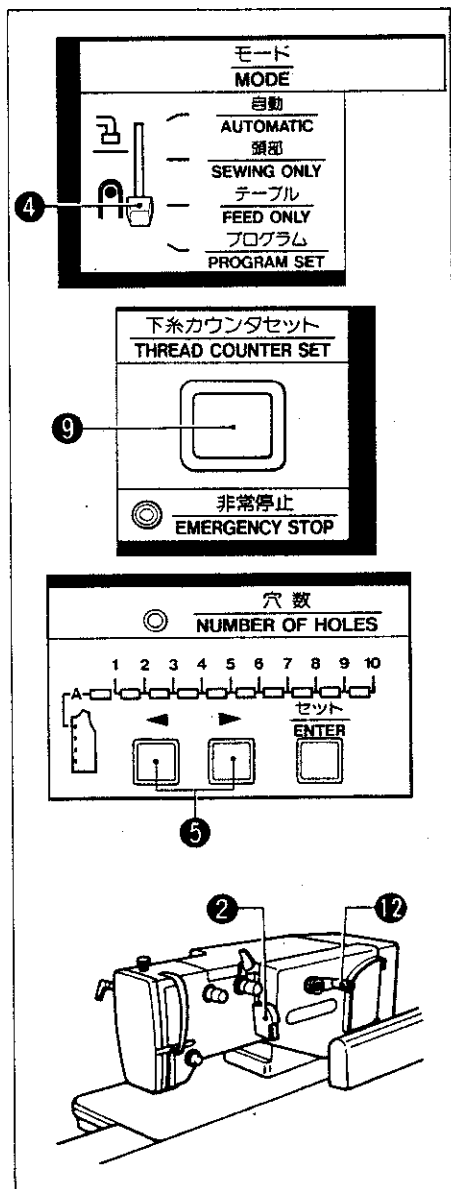

#### 〔Function A〕 Stop sewing and return to home position

- (1) Thread the needle thread when it breaks.
- (2) Reset the MODE selector ④ from AUTOMATIC to FEED ONLY.
- (3) Press EMERGENCY STOP switch ⑨.  
The EMERGENCY STOP indicator will go out, and the material clamp will rise.
- (4) Press the start switch ②.  
The clamp will feed without sewing to the final sewing position and then stop.
- (5) Press the start switch ②.  
The clamp will return to the home position.

#### 〔Function B〕 To sew from one buttonhole before

- (1) Thread the needle thread when it breaks.
  - (2) Press EMERGENCY STOP switch ⑨.  
The EMERGENCY STOP indicator will go out.
  - (3) Press ◀ ⑤. The material clamp will rise.
  - (4) Press the start switch ②.  
The clamp will return to the previous buttonhole.
  - (5) To check the buttonhole position, the material clamp can be raised or lowered using the foot switch ⑪.
- ※ If the clamp is at the home position, the clamp will function when the foot switch ⑪ is pressed.

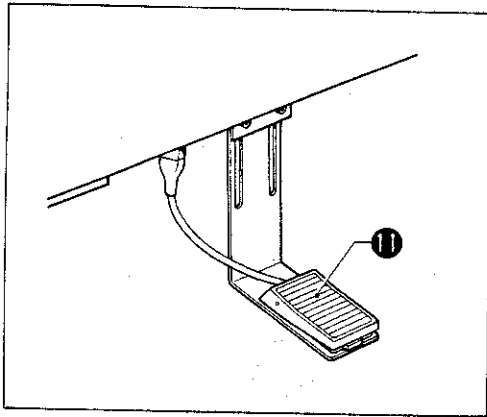

- (6) Press the start switch ② until the machine starts. Continue sewing to the last buttonhole.

★ To feed to and sew from any desired position with FEED ONLY  
 [Function C] To sew from midprogram

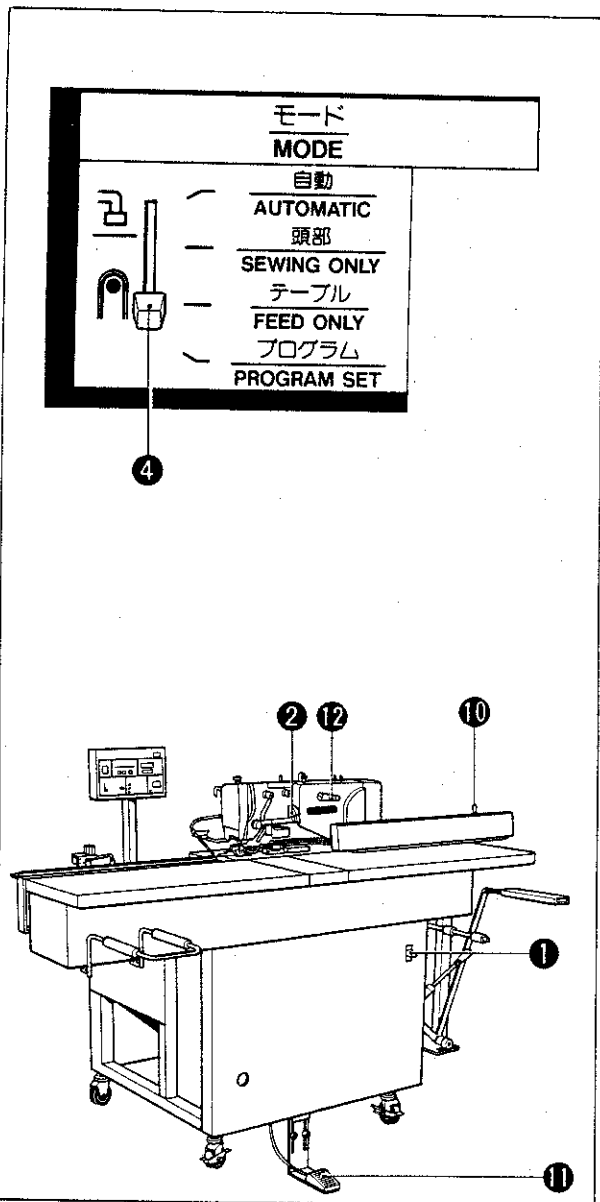

- (1) Set the MODE selector ④ TO FEED ONLY.
- (2) Press foot switch ⑪ and set the material.
- (3) Press the start switch ②. The clamp will move once. Press the start switch ② until the clamp reaches the desired sewing position.
- (4) Reset the MODE selector ④ from FEED ONLY to AUTOMATIC.
- (5) To confirm the buttonhole position, raise and lower the clamp with foot switch ⑪.
- (6) Press start switch ② until sewing starts. Sew one buttonhole.

※ To continue sewing the next buttonhole

- (7) Press start switch ②. The clamp will move once. Repeat steps (6), (7) and (8).

※ To not sew another buttonhole

- (8) Reset the MODE selector ④ from AUTOMATIC to FEED ONLY.
- (9) Press the start switch ②. The clamp will move once. Continue pressing the start switch ② to the last buttonhole position.

※ Using the one-pedal adapter

The foot switch and start switch can be set to operate the same. Functions A, B and C on page 16 and 17 can be used with some slight differences in operation. Those differences are noted below.

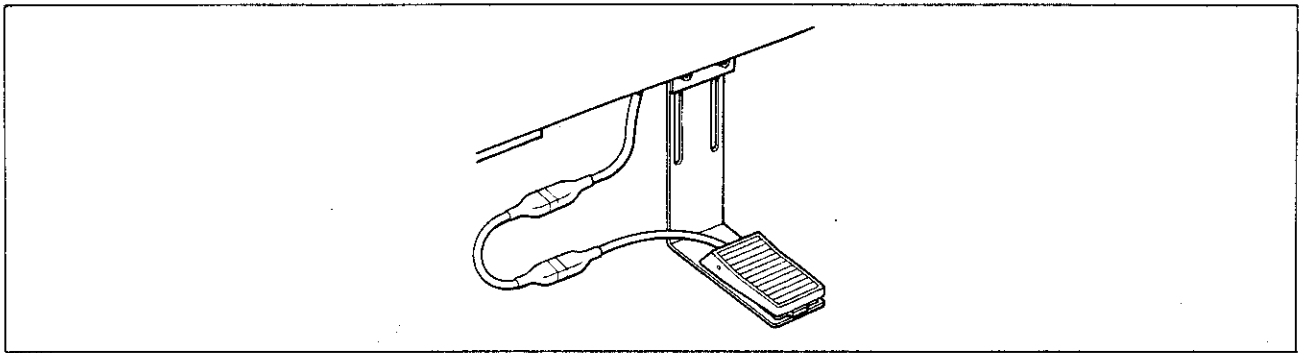

1. [Function B] In step 5, buttonhole position confirmation, press the foot switch and release to raise and lower the clamp; press and hold to continue sewing to the last buttonhole.
2. [Function C] In step 2, pressing the foot switch to set the material will also cause the stacker to move if the stacker is on.
3. [Function C] In step 6, buttonhole position confirmation, press the foot switch and release to raise and lower the clamp; press and hold to sew one buttonhole.

## 5 Setting the thread counter

- ★ The thread counter tells the number of buttonholes which can be sewn with a single bobbin. The counter should be set to the number of buttonholes which can be sewn.
- ★ Set the MODE selector ④ to AUTOMATIC or SEWING ONLY. When the THREAD COUNTER indicator is on, the LED display will show the remaining number of buttonholes that can be sewn with the current bobbin.
- ★ When the thread counter is low or it is not possible to sew a complete workpiece in the AUTOMATIC mode, or if the counter reads [0] when in the SEWING ONLY mode, the BOBBIN EMPTY indicator will flash and sewing will not be possible. Replace the bobbin.
- ★ To replace the bobbin, be sure to follow the procedure below.
  1. Change the bobbin.
  2. To continue operating with the same settings as before, press ENTER ⑤.
  3. To change the thread, needle, buttonhole width, or other parameters, reset the number of buttonholes which can be sewn.

※ To change the thread counter display, use the following procedure.

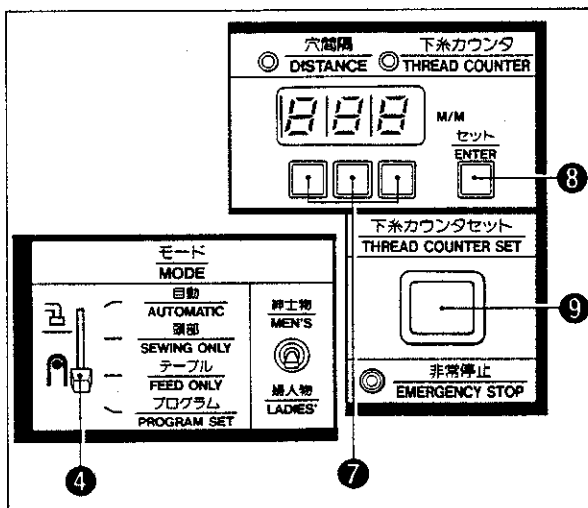

- (1) Set the MODE selector ④ to AUTOMATIC or SEWING ONLY.
- (2) Press switch ⑨.  
The BOBBIN EMPTY indicator will light, and the THREAD COUNTER indicator will flash.
- (3) Use switches ⑦ to change the counter display.  
Pressing switches ⑦ once increments that digit one. Set the counter between 000 and 999.
- (4) Press ENTER ⑧.

## 6 Using the stacker

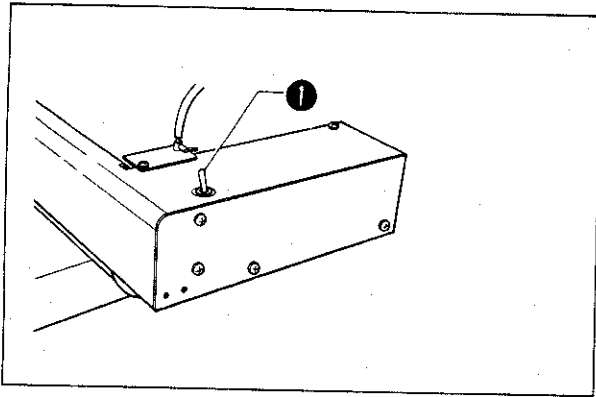

1. Turn the stacker switch ① on. After sewing is completed, the stacker will operate and the workpiece will be draped on the stacker.
  2. Turn the stacker switch ① off to remove the material from the stacker.
- ※ When the clamp is in the material set position when in the AUTOMATIC mode, the stacker can be operated alone by pressing ENTER ⑥.

### Stacker timing adjustment

★ The stacker timing is automatically calculated and stored when dimension A, the number of holes, and the distance are set in the PROGRAM mode and the MODE selector is then reset away from PROGRAM. However, the stacker timing is calculated assuming a standard pattern design, and when sewing non-standard patterns the workpiece may not be evenly stacked as shown below.

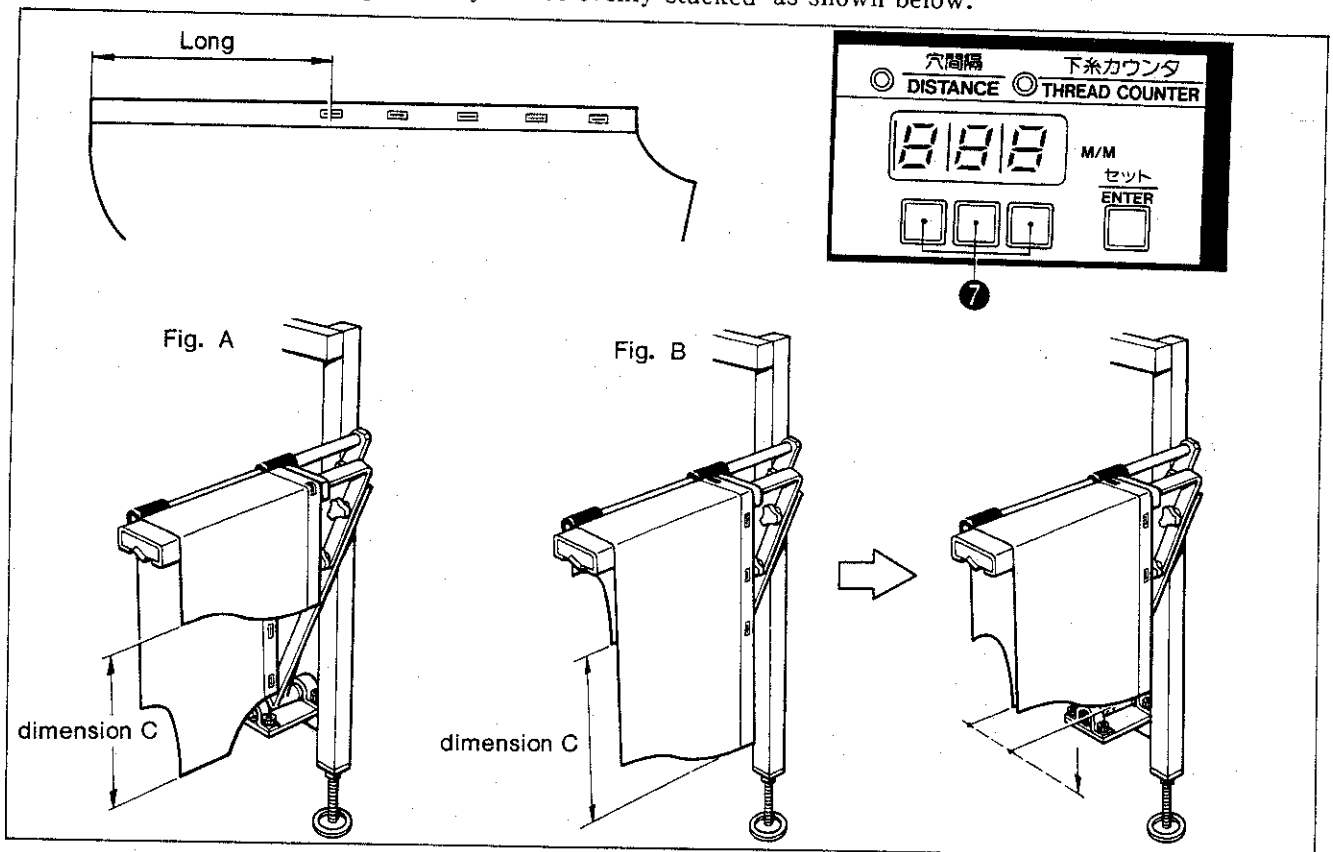

★ Adjustments can be made as follows if the material is particularly uneven when the material is draped over the stacker.

If the clamp is in the material set position when in the FEED ONLY mode, the stacker timing will be displayed in millimeters in the LED display. Switches ⑦ below the display can be used at this time to adjust the timing of the stacker, and therefore the drape of the material.

If the material drapes as in Fig. A, DECREASE the displayed timing.

If the material drapes as in Fig. B, INCREASE the displayed timing.

The displayed number indicates millimeters (mm).

If in Fig. A, dimension C = 100 mm, increase the display by  $100 \div 2 = 50$  mm.

If in Fig. B, dimension C = 100 mm, decrease the display by  $100 \div 2 = 50$  mm.



## 7 Checking clamp movement and stacker operation

- (1) Set the MODE selector ④ to FEED ONLY.
- (2) Set the stacker switch ⑩ on.
- (3) Insert the material under the material clamp and aligned with the leading edge guide, and press the foot switch ⑪. Clamps R and L will descend and clamp the material.
  - ※ To reset the material, press the foot switch ⑪ again. The clamp will rise.
- (4) Press start switch ②.
- The clamp will move to the right the feed distance between the buttonhole positions.
- (5) Press start switch ② until the clamp is fed to the final feed position.
- (6) Press start switch ②.
- The clamp will return to the material set position (start position), and the stacker will operate.
- (7) If the clamp is holding the material and MODE selector ④ is set to FEED ONLY, the position held by the clamp will be displayed in the LED in millimeters.
  - ※ To change the stacker clamp position, see stacker timing adjustment on page 20.
- (8) Set stacker switch ⑩ to OFF to remove the material.
  - ※ If clamp movement is checked and the clamp is returned to the material clamp position with the stacker switch ⑩ off, the leading edge guide may descend and clamp the material. If this happens, set MODE selector ④ to SEWING ONLY; the leading edge guide will rise and the material can be removed. (This is the same as during automatic sewing.)

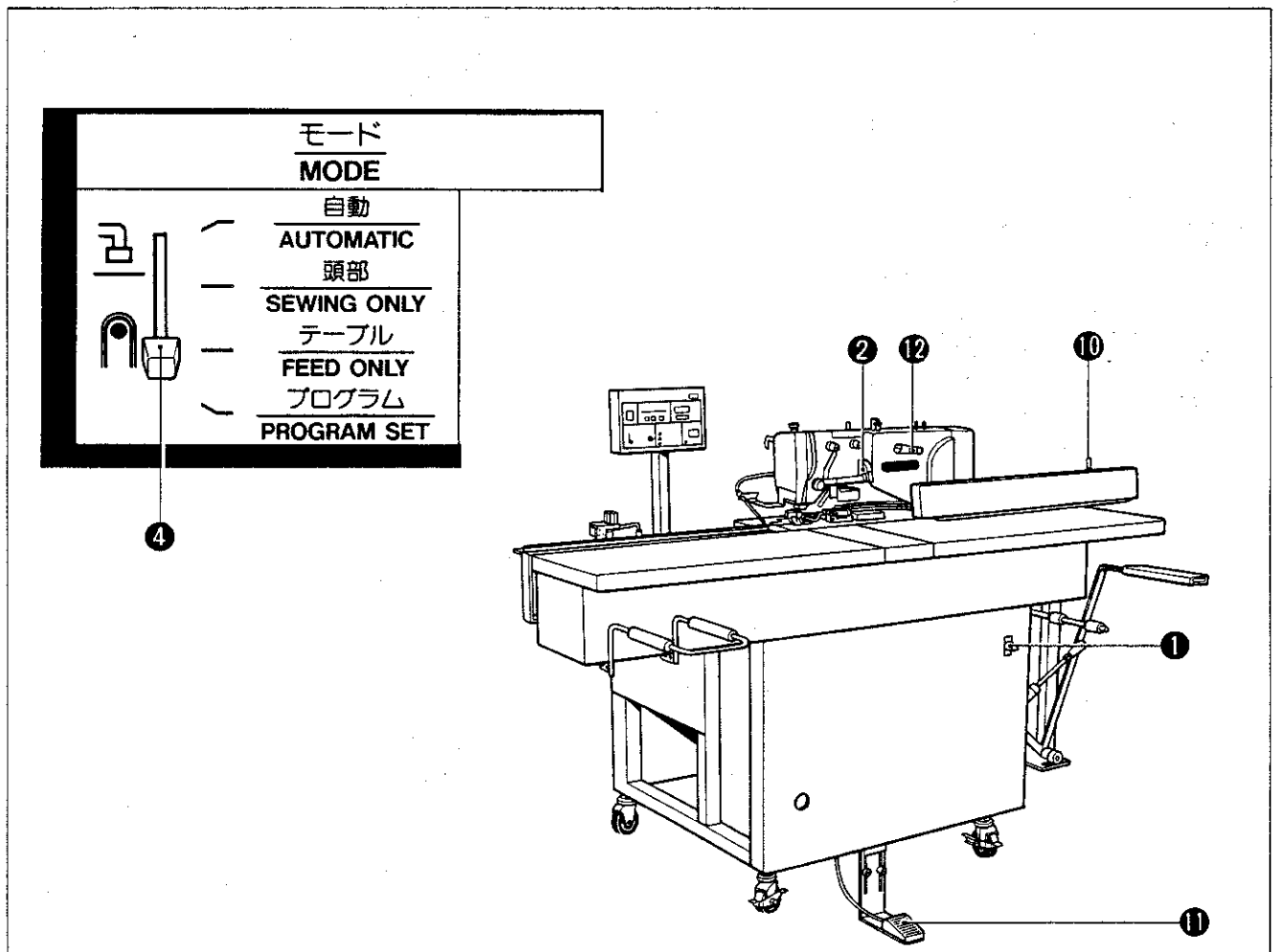

## 8 Clamp L adjustment

★ Clamp L ① is designed so that its position relative to the buttonhole can be changed with the pulse motor.

### 1. Calculating clamp L position

When the MODE selector is set to any position other than PROGRAM after setting dimension A, the number of holes, and the interval in the PROGRAM mode, the position of clamp L will be 40 mm after the last buttonhole position. This position is automatically calculated and stored in memory.

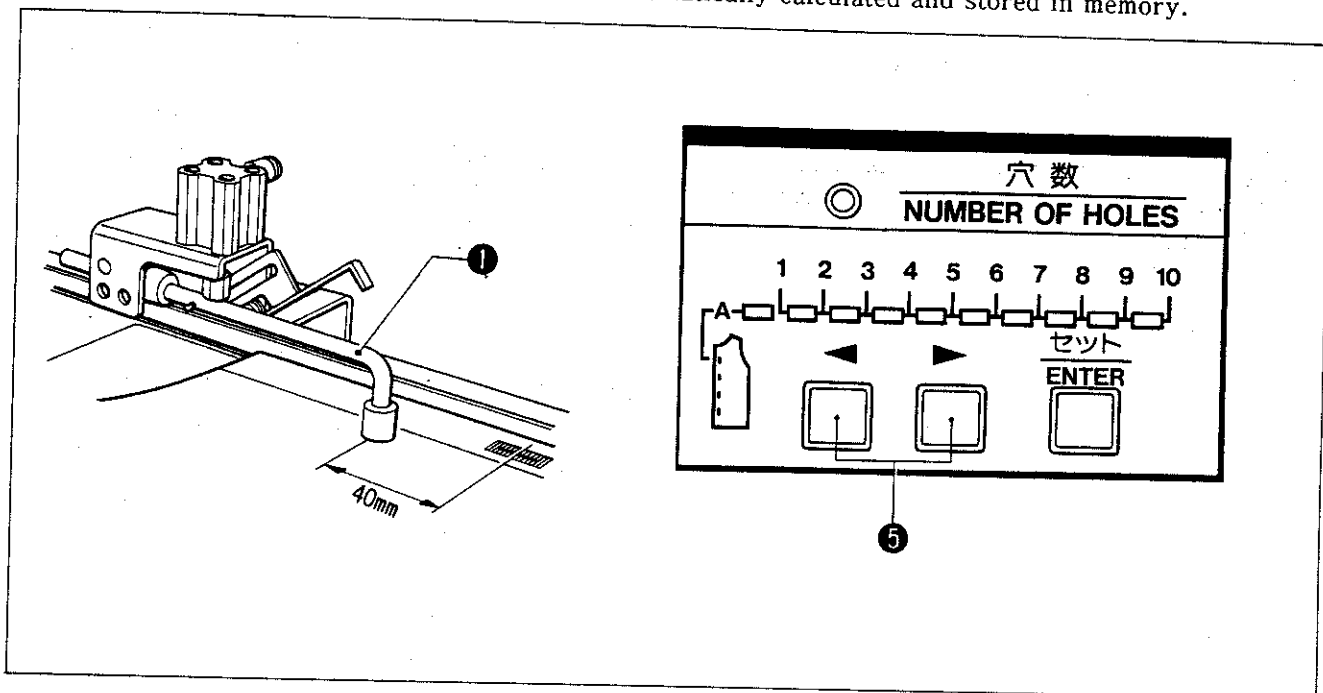

### 2. To change the position of clamp L

※ The position of clamp L ① can be changed with the AUTOMATIC mode switch before the material is set.

The arrow switches ◀ and ▶ ⑤ will shift clamp L  $\pm 3$  mm each time the switch is pressed; the new position will be automatically stored.

Press ◀ ⑤ to shorten the distance 3 mm ( $-3$  mm), and ▶ ⑤ to lengthen the distance 3 mm ( $+3$  mm).

※ When the sewing program is reset in the PROGRAM mode, the position of clamp L ① will be automatically recalculated and any change which had been made will be lost.

※ The shortest mechanical distance possible between clamp L ① and the center of the buttonhole is 40 mm. Attempting to set any shorter distance will cause a PROGRAMMING ERROR to be indicated, and the setting will be ignored.

Also, clamp L can be shifted to the left by pressing ◀ ⑤ until the home position sensor is tripped.

When the home position switch is tripped, a PROGRAMMING ERROR will be indicated. Release ◀ ⑤ to cancel the PROGRAMMING ERROR indicator.

※ The position of clamp L cannot be changed when the garment type selector is set to LADIES'.

## 9 Leading edge guide timing adjustment

- ★ If the garment type selector 13 is set for LADIES' garments, the leading edge guide will be raised.
- ★ The leading edge guide 2 will be raised after the first buttonhole is sewn when in the MEN'S garment mode and the MODE selector is at AUTOMATIC.

The leading edge guide will descend again when:

- a. The start switch is turned on

The leading edge guide will descend after the stacker roller carries the material to the stacker and material is placed under the leading edge guide.

- ※ If the distance from the last button to the material edge is greater than 250 mm, set DIP switch 1 3 on the main circuit board off.

- ★ If the distance from the last button to the material edge is less than 250 mm and DIP switch 1 3 is off

- (1) The cycle time will be increased.
- (2) Wear of the stacker roller belt will increase.

Due to these problems, if the distance from the last button to the material edge is less than 250 mm, make sure DIP switch 1 3 is ON.

- b. If the stacker switch is OFF

The leading edge guide will descend approximately 2 seconds after sewing is completed. Remove the material before the leading edge guide descends.

- ★ When the leading edge guide descends, the next workpiece can be set and sewing can be started even if the stacker is still operating.

- ★ Set the MODE selector to SEWING ONLY to remove the material if the leading edge guide descends and clamps the material. The leading edge guide will rise.

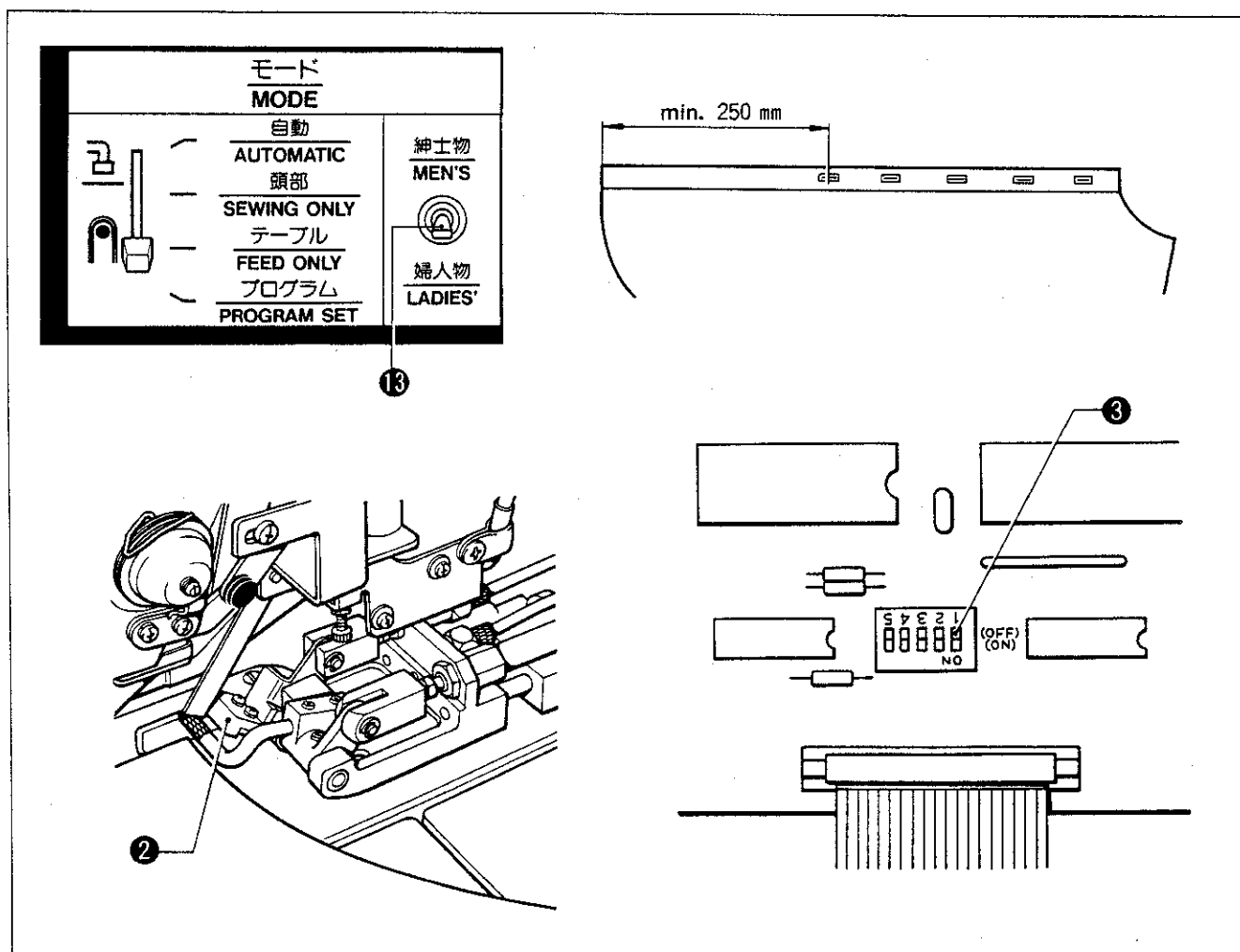

## 10 Sewing counter

- ★ The number of pieces (0 - 999) to be sewn is displayed in the LED when the MODE selector ④ is at AUTOMATIC, the clamp is at the material set position, and ENTER ⑧ is pressed.
- ※ The sewing counter increments 1 each time a complete piece is sewn when MODE selector ④ is set to AUTOMATIC.
- ※ To clear the sewing counter (reset it to 0), press and hold ENTER ⑧ and press the EMERGENCY STOP switch ⑨.
- ※ The contents of the sewing counter will be retained even after the power switch ① is turned off.
- ※ When the number of work pieces sewn exceeds 999, a decimal point will be displayed.

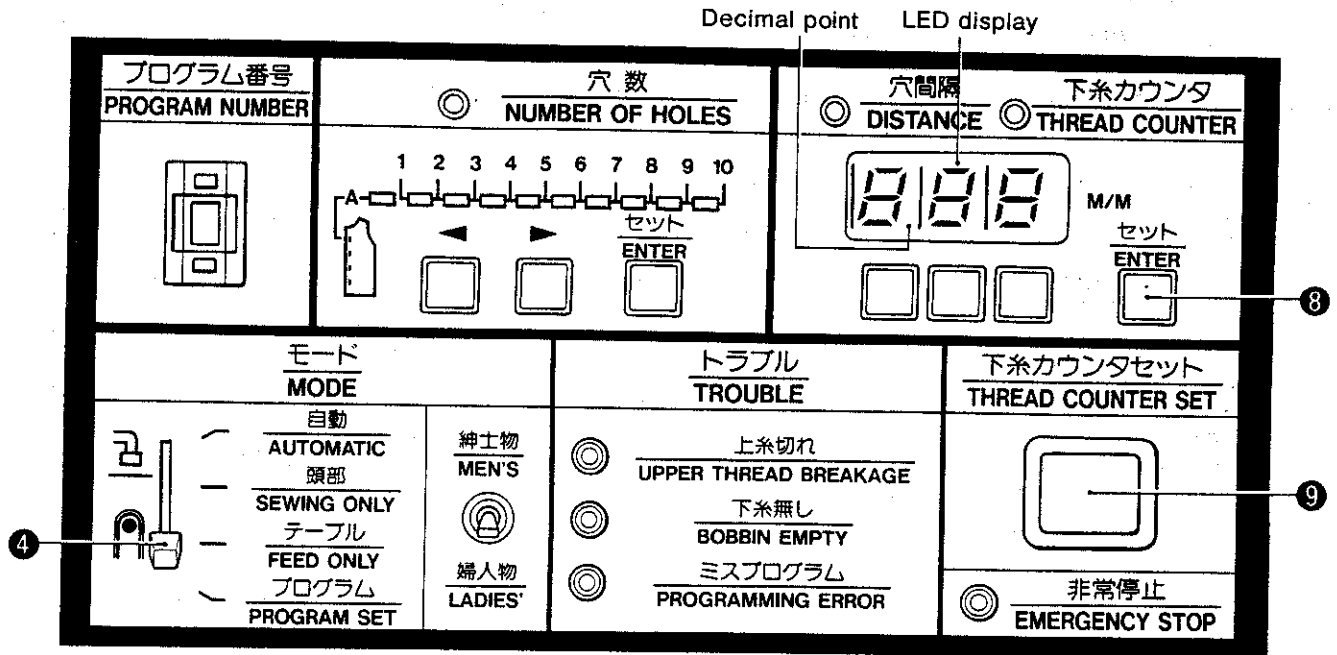

## 11 Sewing long garments

- ※ When DIP switch 2 ① on the control circuit board is OFF, the maximum clamp stroke is 600 mm. To sew longer garments, turn DIP switch 2 ① ON. This will set the maximum clamp stroke to 1150 mm. The maximum distance which can be covered by the clamp in a single operation is 600 mm. To travel distances greater than 600 mm, the clamp will automatically reset and reclamp the workpiece. A decimal point will be displayed in the LED when the clamp has shifted and reclamped the workpiece.

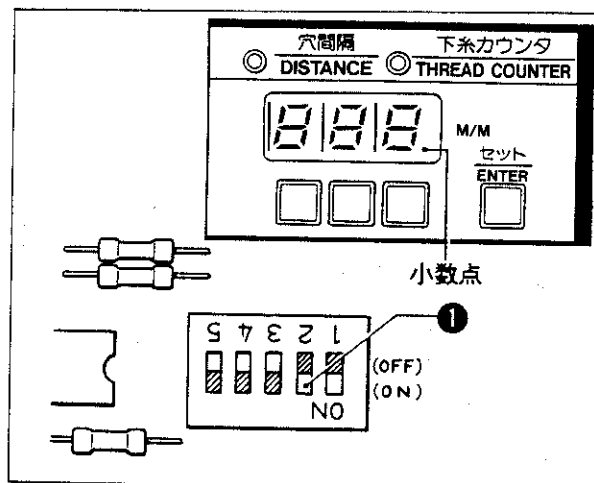

- ※ Turn the power switch off before resetting DIP switch 2 ①.

- (1) Remove the set screw, and remove the side cover to the control box.
  - (2) To sew long garments, turn DIP switch 2 ON. Set DIP switch 2 OFF.
  - (3) Input the sewing program before sewing.
- ※ DIP switch 2 is set OFF at the factory prior to shipping.

## 12 Adjusting the air vents

The air flow through the air vents can be adjusted with the air cocks to make it easier to work with light materials.

If the material seems to turn or fold, turn air cocks 2 and 4 in the direction of the arrow to close air vents 2 and 4. (See the figure below.)

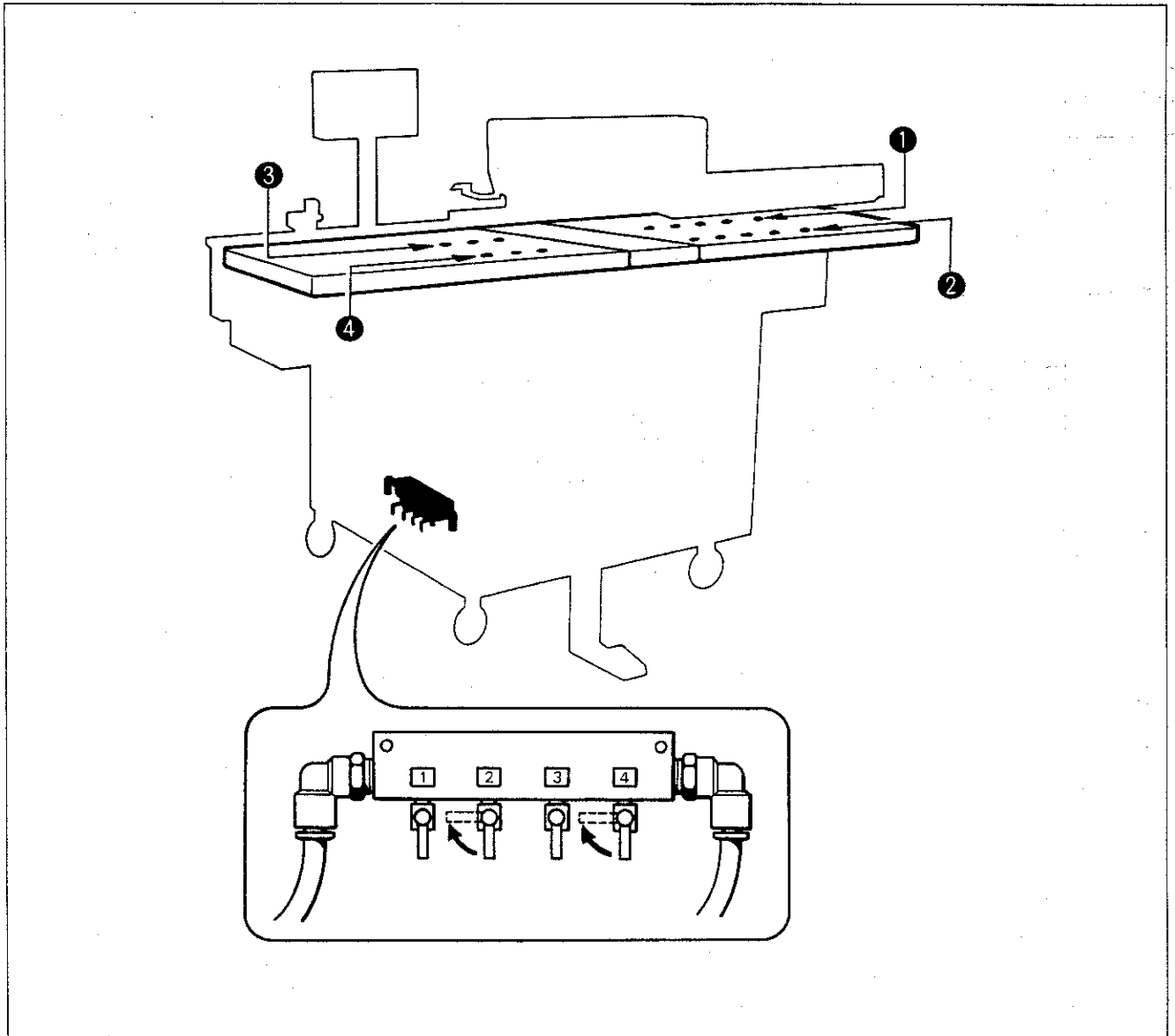

### 13 Tilting the machine head

Follow the procedure below to tilt the machine head.

1. Turn power switch ① on.
2. Press the start switch ②, and move the clamp to the start position.
3. Set the MODE selector ③ to SEWING ONLY.
4. Press ► ④, and move clamp R to the right.
5. TURN THE POWER OFF.
6. Loosen the two thumb screws ⑥ in bodice support rear ⑤, and then slide bodice support rear ⑤ in the direction of the arrow to remove.
7. Move belt cover ⑦ in the direction of the arrow to remove.
8. Tilt the head.

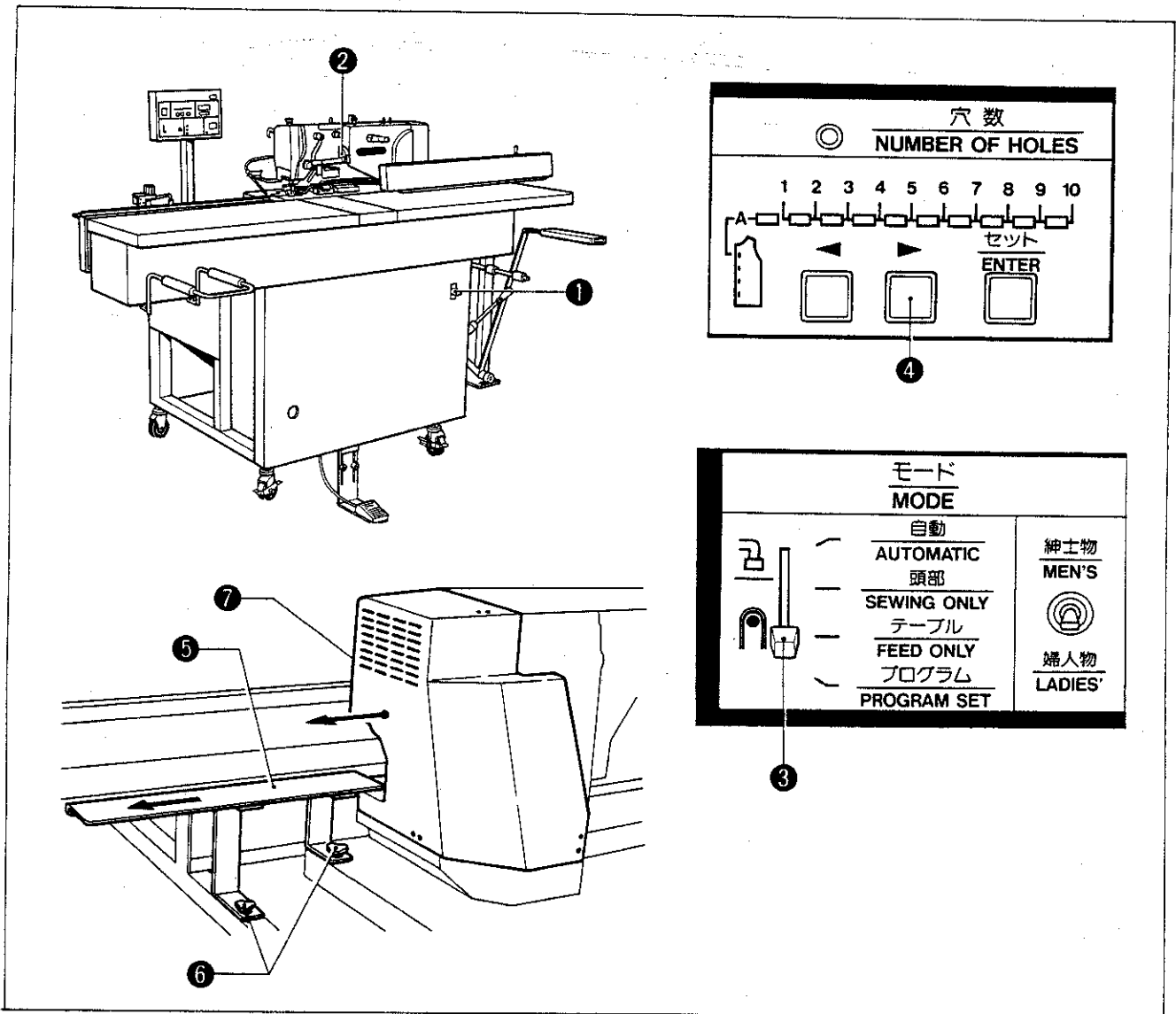

## 14 To change the buttonhole size

1. Refer to the table below to determine the correct gauge parts when replacing a gauge.

Size	Cutter	Material clamp assembly (size)	Needle plate (size)	Base needle plate
3/8" (9.5mm)	109837-001	S00643-001 (12.7mm)	(1.4mm) S00652-001	S00647-001
7/16" (11mm)	107204-001		or S00646-001 (1.2mm)	
1/2" (13mm)	107200-001			
5/8" (16mm)	107205-001	159072-001 (16mm)	S00996-001 (1.4mm)	
3/4" (19mm)	107207-001	159074-001 (22mm)	S01001-001 (1.4mm)	S01000-001
7/8" (22mm)	109838-001			

★ Follow the procedure below to change gauge parts.

1. Loosen screw ①, and remove needle ②.
2. Remove screw ③, and remove cutter ④.
3. Remove presser foot adjustment screw ⑤.
4. Manually raise length feed arm ⑥, and place a block under the arm ⑥.
5. Remove screw ⑧, and remove material clamp ⑦. (Be careful not to lose spring ⑭.)
6. Remove thumbscrew ⑨, and remove vertical ruler ⑩.
7. Remove screw ⑪, and remove needle plate ⑫.

※ The base needle plate ⑬ must also be changed to sew buttonholes 3/4" (19 mm) or 7/8" (22 mm) long. (See the following page.)

To reassemble, note the precautions and reverse the above order.

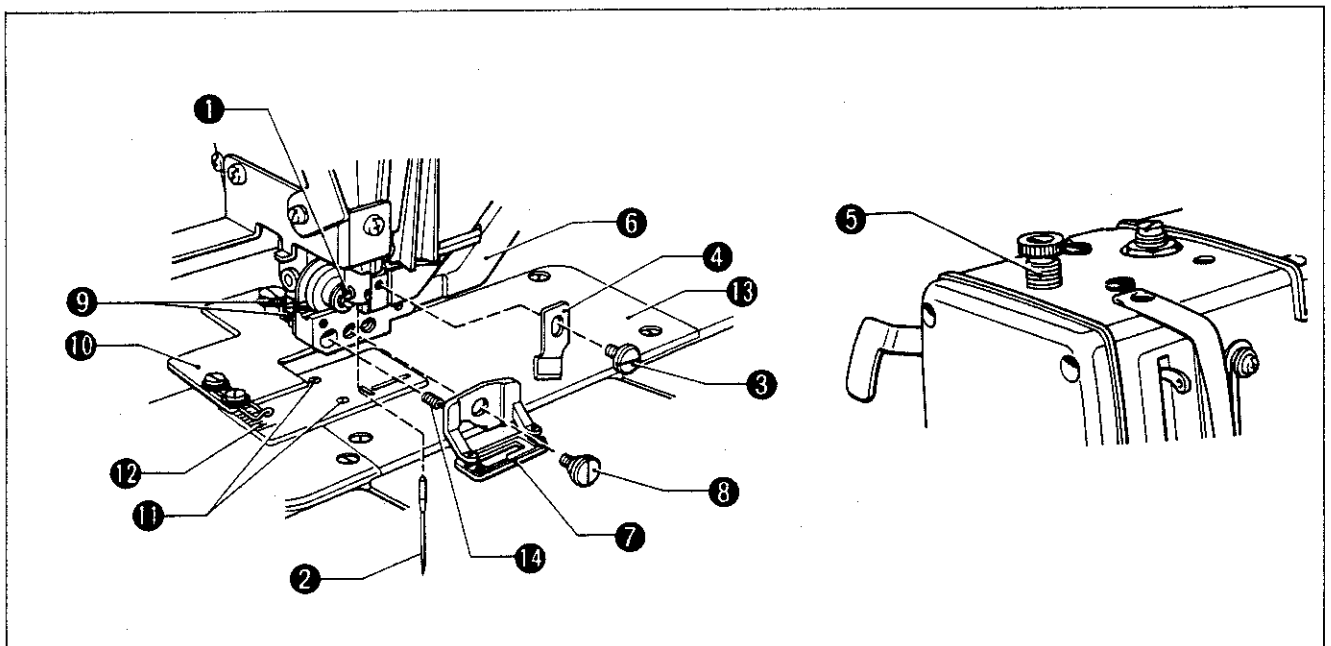

## Removing the base needle plate

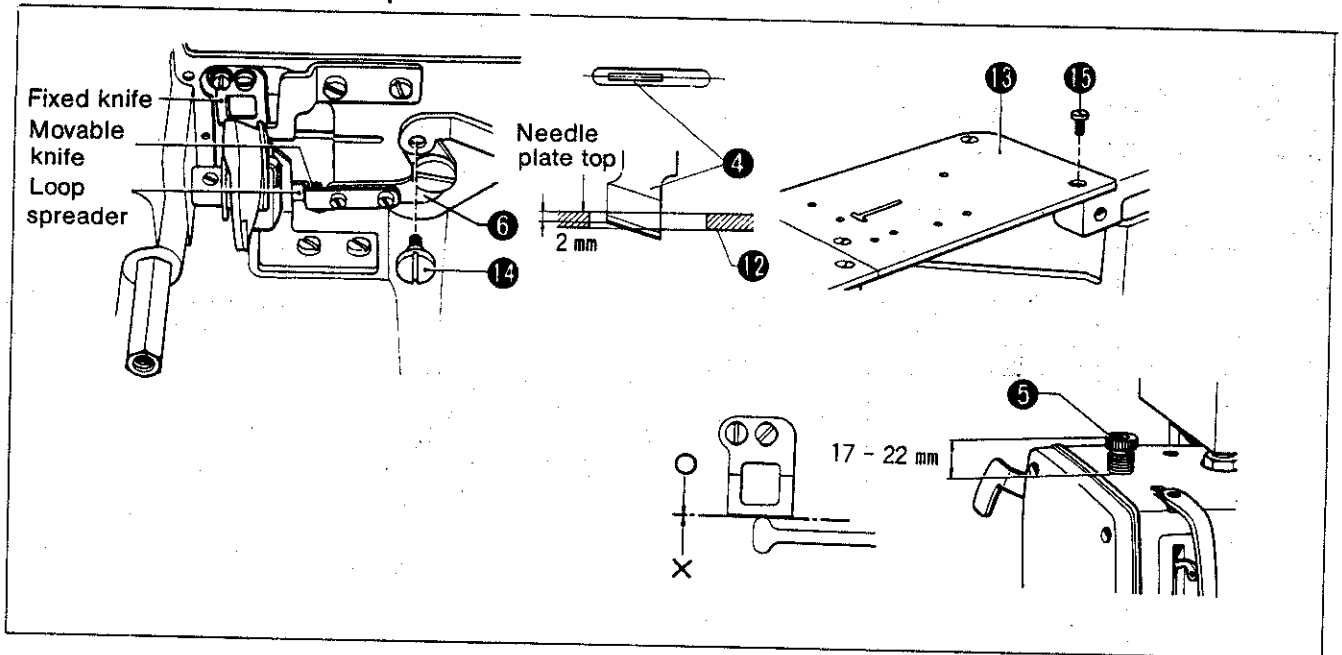

8. Remove set screw 15, and remove base needle plate 13.
9. To change base needle plate 13, remove the movable knife, loop spreader, and fixed knife, and then install the new base needle plate.

※ See page 26 for tilting the machine head.

### ◎ Cautions on installing the base needle plate

1. Adjust the height of cutter 4.  
Install cutter 4 so that there is a 2 mm gap from the blade of cutter 4 to the top of needle plate 12 when the cutter 4 is fully lowered.
  2. Loosen set screw 15 and move base needle plate 13 so that the cutter is aligned with the center of the cutter groove when the cutter 4 enters the cutter groove in the needle plate 12.
  3. Adjust the height of presser foot adjustment screw 5 to 17 - 22 mm as shown in the figure.  
※ When replacing base needle plate 13, make sure the fixed knife does not extend to the cutter groove side.  
Make sure knife operating lever 16 moves lightly.  
Tighten step screw 14 firmly.  
Make sure the gap between the shuttle body and shuttle body stop is 1 - 1.5 mm. (See page 10 in the LH4-B815 instruction manual to adjust.)
- ※ See the LH4-B815 instruction manual regarding adjustment of the stitch number, buttonhole length, buttonhole width, and reference buttonhole position.



★ Adjust the position of the slide base ①.

(1) Set the MODE selector ⑨ to SEWING ONLY.

(2) Press ► ⑩ to move clamp R ③ to the right.

(3) Loosen the two screws ④, and set the gap between slide base ① and needle late ② to 1 mm at the home position.

※ Make sure slide base ① does not contact the head when the clamp R ③ moves right and left.

※ Test run the machine, and check the buttonhole length.

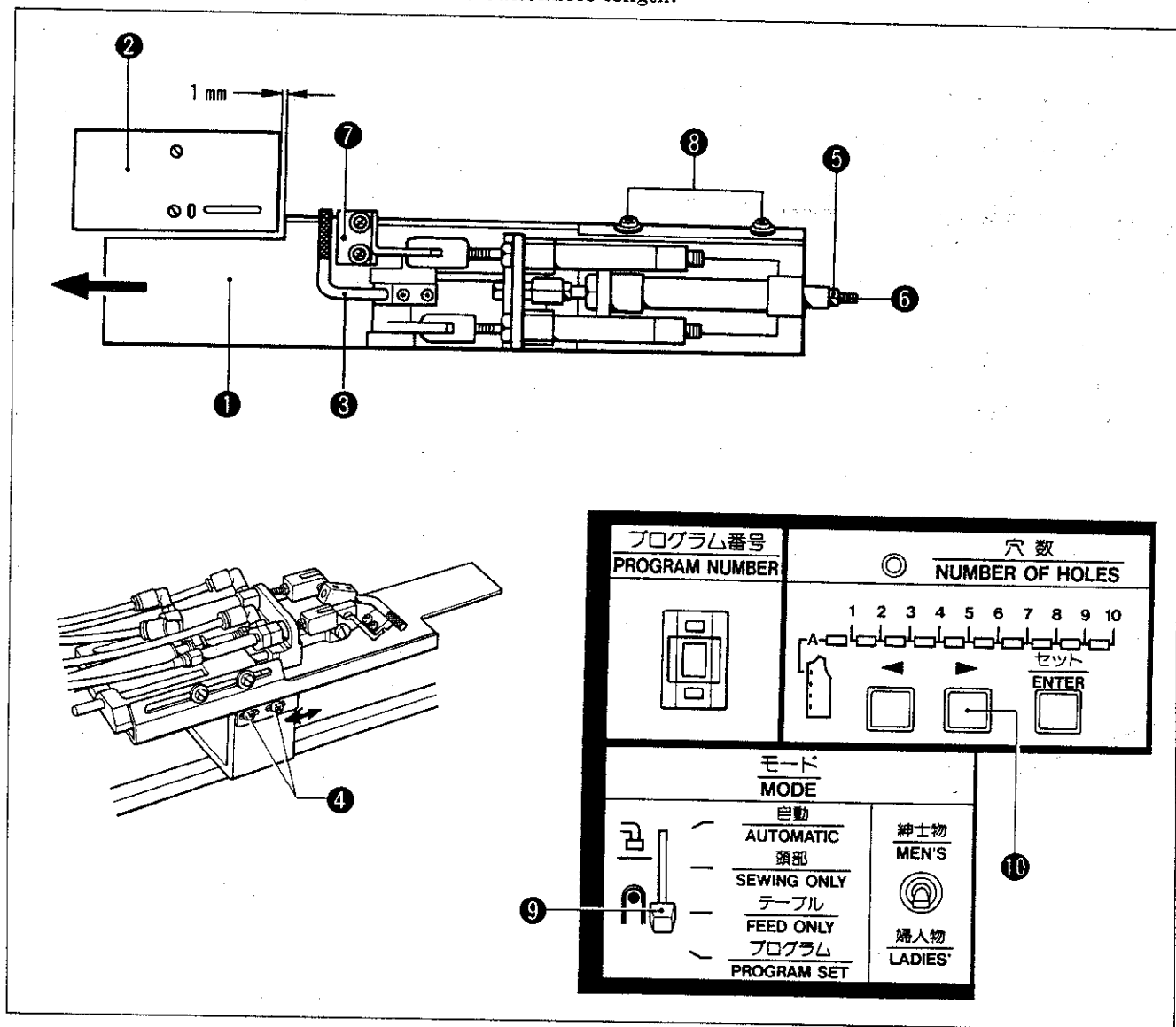

2. Adjust the free material area.

- (1) Loosen nut ⑤, measure the length of the threads on air cylinder shaft ⑥, and adjust the size of the free material area.

※ If the thread length (a) is 16 mm, the free area will be 30 mm.

$$\text{Free area} = a + 14 \text{ mm}$$

For example, to set the free area to 17 mm, set thread (a) to 3 mm. Use the provided scale to adjust the free area.

$$17 \text{ mm} = a + 14 \text{ mm}$$

$$a = 17 \text{ mm (free area)} - 14 \text{ mm}$$

$$a = 3 \text{ mm}$$

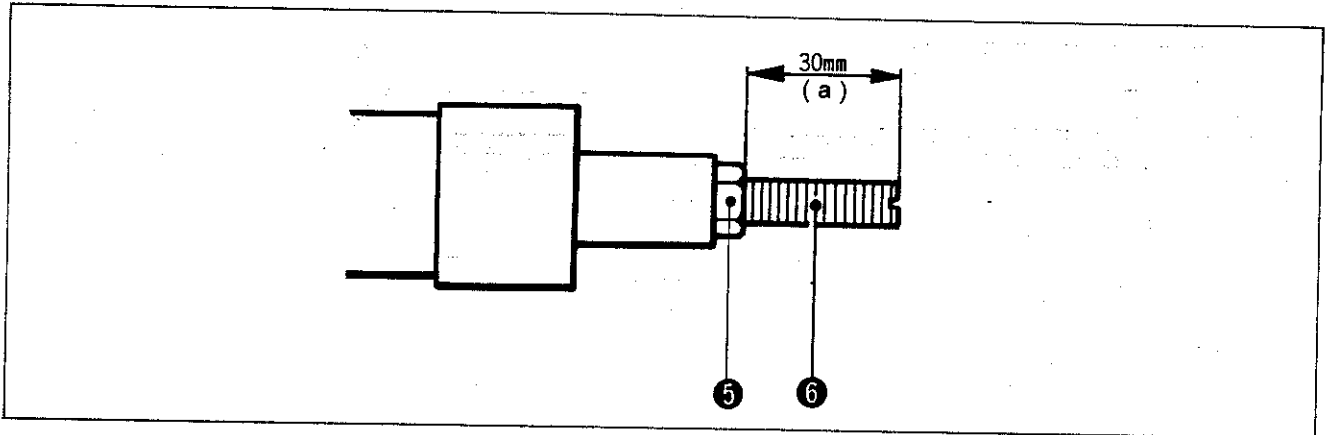

3. Adjust the leading edge guide ⑦ position.

- (1) Loosen the two set screws ⑧, move clamp R ③, and use the provided scale to adjust the position of leading edge guide ⑦.

※ The position of leading edge guide ⑦ is: dimension A +  $\frac{b(\text{buttonhole length})}{2}$

For example, if the buttonhole length is 16 mm, then the position of the leading edge guide is:

$$\text{dimension A} + \frac{16}{2} =$$

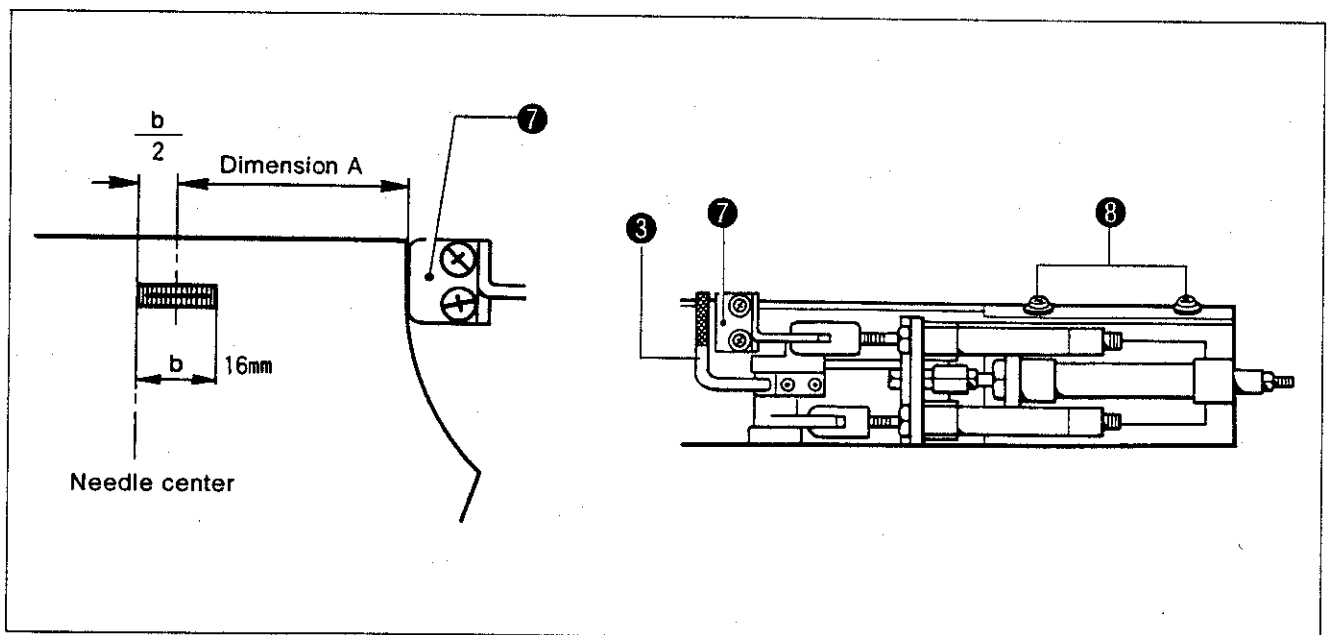

## 15 Other precautions

1. If the machine is not used for an extended period of time (1 - 2 months), data may be erased from memory. Be sure to turn the power on for at least 15 minutes once a month.
  2. Programs in memory can be affected by electrical noise caused by lightning. Disconnect the power cord during lightning storms.
  3. If non-program characters are displayed in the LED display when the power is turned on or during sewing, the machine will not operate. Contact your Brother dealer for service.
- If an error message is displayed on the operation panel display, refer to the table below.

### ERROR MESSAGES

Display	Problem
E-1	Start switch is already on when the power switch is turned on.
E-2	Foot switch is already on when the power switch is turned on.
E-3	The home position sensor is on (interrupted) during home search even though the clamp is not at the home position, or the sensor is not on when at the home position.
E-4	The clamp position sensor is on (interrupted) during home search even though the clamp is not at the home position.
E-5	The clamp position sensor does not come on during home search even though the clamp is at the home position.
E-6	The machine stop switch is off during home position search.
E-7	The machine stop switch is on even after sewing starts during the AUTOMATIC and SEWING ONLY modes.
E-8	Clamp feed (feed motor) does not stop within the specified time during feed in the AUTOMATIC and FEED ONLY modes.
E-9	When the power is turned on, the stacker motor signal is not output, or the stacker does not operate at the right time.
E-A	Material clamp does not rise though sewing is completed in the AUTOMATIC and SEWING ONLY modes.
E-C	Machine stop switch does not come on even though sewing is completed in the AUTOMATIC and SEWING ONLY modes.
E-F	Control circuit board element defect.

#### Alphanumeric display sample

	0	1	2	3	4	5	6	7	8	9	-	A	b	C	d	E	F
LED display	0	1	2	3	4	5	6	7	8	9	-	A	b	C	d	E	F

### What to do when the memory fails

- (1) Voltage drop in the backup capacitor for the main circuit board (caused by long-term non-use)
- (2) Lightning or power line noise caused (particularly when the power supply is not properly grounded)

In the event of either (1) or (2) above, memory contents may change or be deleted. If this happens, the following may occur.

- ① When the power switch is turned on, the LED on the operation panel and the sewing counter will blink, and the clamp will not move to the start position even if the start switch is pressed.
- ② After the clamp moves to the start position, the PROGRAMMING ERROR indicator will light, and automatic sewing will not be possible.
- ③ When the program number is changed, the PROGRAMMING ERROR indicator will light, and automatic sewing will not be possible.

If any of the above occur, do the following to restore the memory contents.

A. In the event of ① above, the sewing counter will have changed.  
Press ENTER **6**. The sewing counter indicator will stop blinking, and the clamp will return to the start position when the start switch is pressed.

B. In the event of ② and ③ above, the contents of the program stored at the selected program number have changed. Follow the procedure for a programming error and reprogram the sequence.

※1. Only a 3 digit number can be displayed in the LED, but it is possible for a number greater than 0 to be in the 4th digit.

※2. Only a single digit in the LED may have disappeared.

In the event of ※1 or ※2 above, press switches **7** to advance through the numbers 0 → 1 → 2 ... 9 → 9 → 0 and reset the display to the contents of the program.

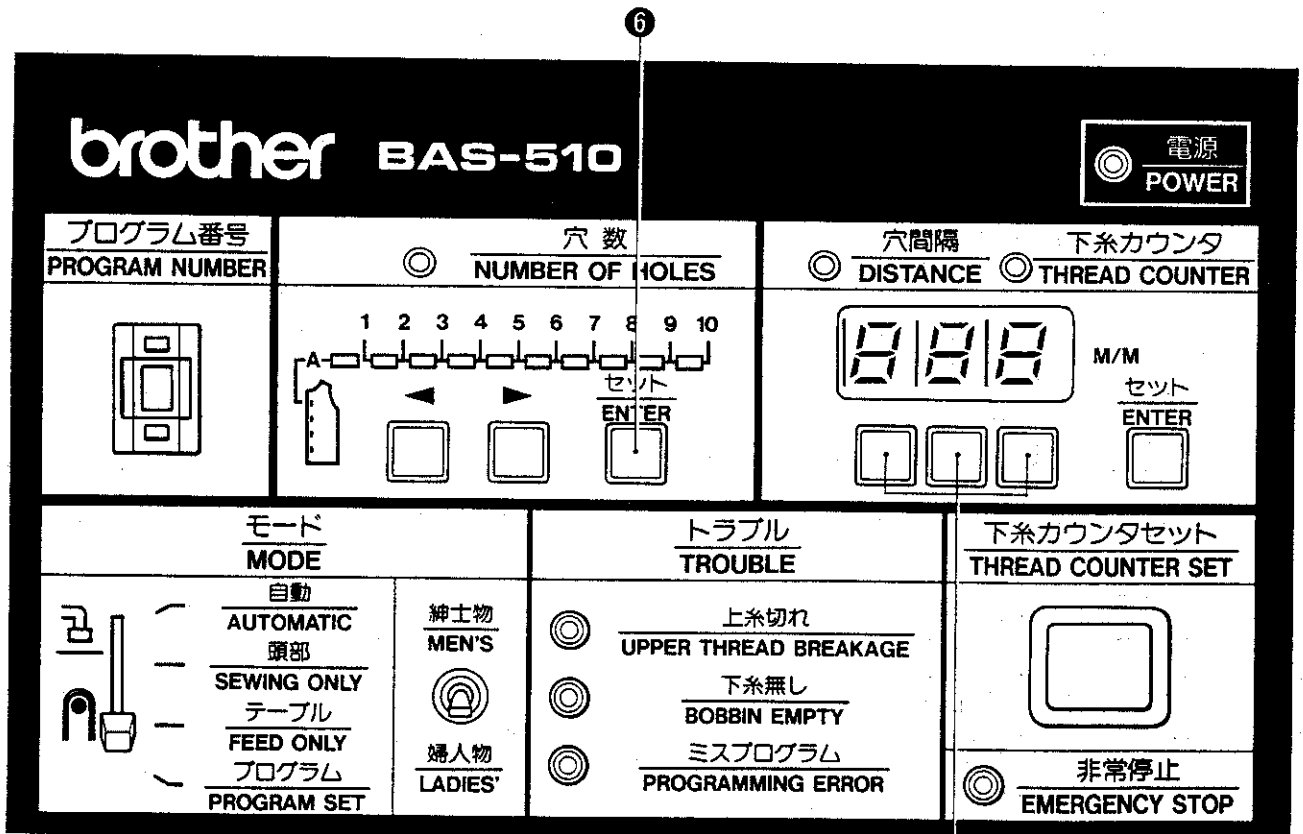

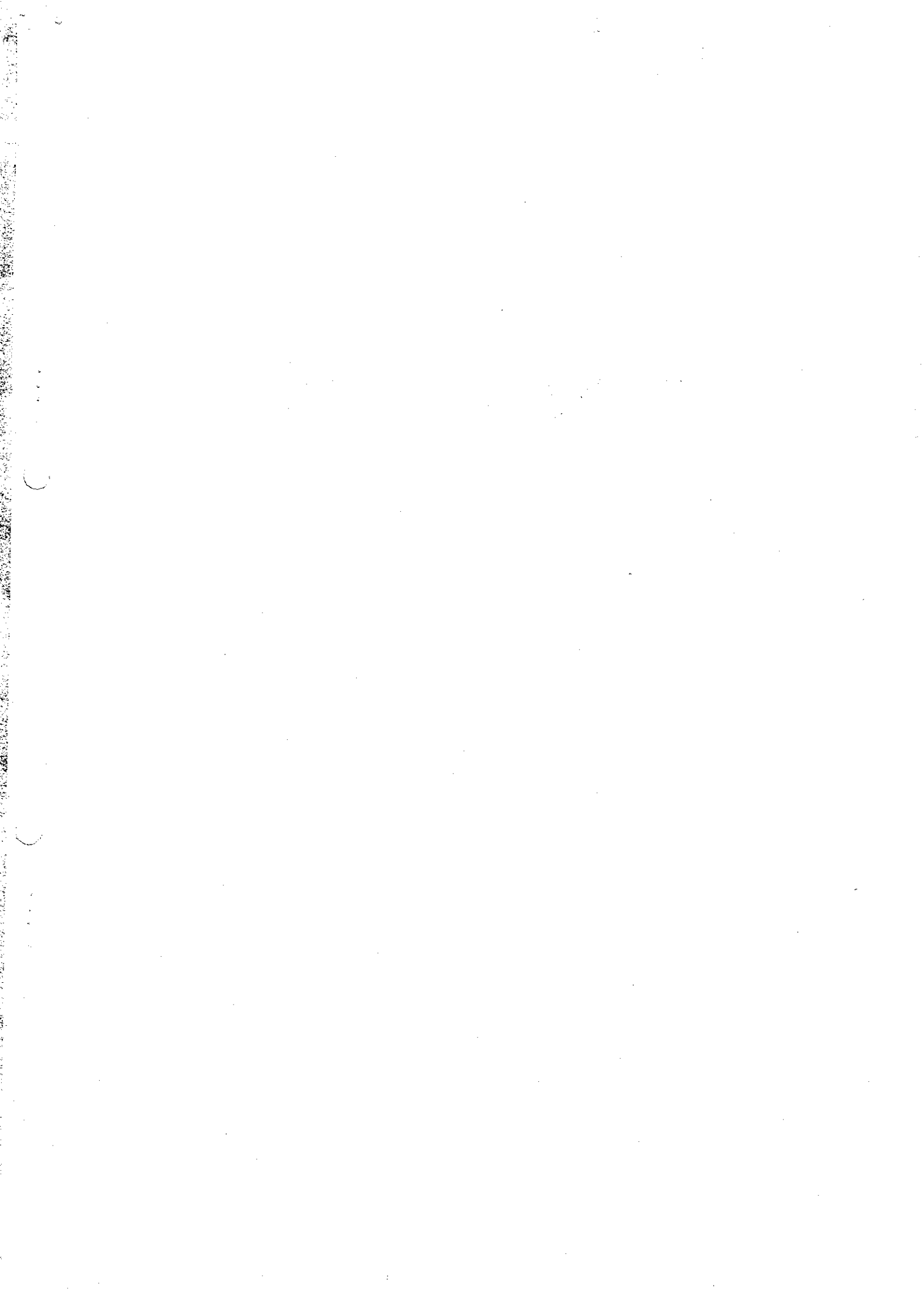

06 09 82 33 48