

**JUKI**

**1-Needle, Post-Bed, Lockstitch Machine with Wheel  
Feed, Driven Roller Presser, Reverse Feed  
Mechanism and Automatic Thread Trimmer**

**PLW-1246-6**

**ENGINEER'S MANUAL**

---



## PREFACE

This Engineer's Manual is written for the technical personnel who are responsible for the service and maintenance of the machines. The Instruction Manual for these machines intended for the maintenance personnel and operators at an apparel factory contains detailed operating instruction. And this manual describes "How to Adjust", "Effects of Adjustment", and other information which are not covered by the Instruction Manual. It is advisable to use the pertinent Instruction Manual and Parts List together with this Engineer's Manual when carrying out the maintenance of these machines. This manual mainly consist of three sections; the first section presents "Standard Adjustment", the second section, "How to Adjust", and the third, "Results of Improper Adjustment".

1.	SPECIFICATIONS . . . . .	1
2.	STANDARD ADJUSTMENTS . . . . .	3
	(1) Needle bar . . . . .	3
	1) Needle entry point . . . . .	3
	2) Height of the needle bar . . . . .	3
	(2) Timing between the needle and the hook . . . . .	5
	1), 2) Rising amount of the needle and the position of the blade point . . . . .	5
	3) Clearance between the needle and the blade point of the hook . . . . .	5
	(3) Bobbin case opening lever . . . . .	7
	(4) Clearance between the throat plate and the bobbin case stopper . . . . .	7
	(5) Timing of the cloth feed movement . . . . .	9
	(6) Height of the bottom roller . . . . .	9
	(7) Position of the top roller . . . . .	11
	(8) Adjusting the top feed amount . . . . .	11
	(9) Lower clutch . . . . .	13
	(10) Timing of main shaft vs. intermediate shaft vs. hook driving shaft . . . . .	15
	(11) Safety mechanism . . . . .	17
	1) Releasing the safety mechanism . . . . .	17
	2) Adjusting the safety mechanism . . . . .	17
3.	ADJUSTMENTS OF ADDITIONAL DEVICES . . . . .	19
	(1) Thread trimmer . . . . .	19
	1) Initial position of the rotary knife . . . . .	19
	2) Stroke of the rotary knife . . . . .	21
	3) Position of the thread trimming cam . . . . .	21
	4) Thread trimming timing . . . . .	21
	5) Clearance between the periphery of the thread trimming cam and the cam roller . . . . .	23
	6) Adjusting the pressure of the counter knife . . . . .	25
	7) Adjusting the clamp spring pressure . . . . .	25
	8) Automatic reverse feed device . . . . .	27
	(2) Tension disc floating device . . . . .	29
	1) Floating amount of the disc . . . . .	29
4.	ADJUSTMENT VALUES FOR THE SPECIAL TYPE APPLICATION . . . . .	31
	1) When using andaria thread . . . . .	31
	2) When using nylon bond thread . . . . .	32
5.	LIST OF SELECTABLE JOINING PART . . . . .	33
6.	LIST OF CONSUMABLES . . . . .	33
7.	POINTS TO BE APPLIED WITH LOCKTITE . . . . .	33
8.	OTHER SPECIAL INFORMATION . . . . .	34

9.	TROUBLES IN SEWING OPERATION AND CORRECTIVE MEASURES . . . . .	35
10.	TROUBLE IN FUNCTIONS OF ADDITIONAL DEVICES AND CORRECTIVE MEASURES . . .	45
11.	TABLE DIMENSIONAL DIAGRAM . . . . .	50
12.	TABLE OF EXCHANGING GAUGE PARTS . . . . .	51

No.	Item	Specification
1	Model	PLW-1246-6
2	Name	1-needle, post-bed, wheel-feed, reverse-feed lockstitch machine with an automatic thread trimmer
3	Application	Sewing shoe toe caps
4	Sewing speed	Up to 2,500 s.p.m. (Max. 2,500 s.p.m.) (Normal 2,000 s.p.m.)
5	Needle	SCHMETZ 134LR Nm65 to Nm125 (standard Nm90)
6	Thread	#8 to #40 (standard #20)
7	Width of needle hole in throat plate	1.2, 1.6, 2.1 (standard 1.6)
8	Stitch length	0.8 mm (0.031") to 4.5 mm (0.177")
9	Lift of presser foot	By the hand lifter: 7 mm (0.276") By the knee lifter: 9 mm (0.354")
10	Stitch adjustment mechanism	Push-button system
11	Reverse feed	By the external magnet (touch-back device with manual lever)
12	Thread take-up	Link-type thread take-up
13	Needle bar stroke	38 mm (1.496")
14	Hook	Thread trimming vertical axis hood with a bobbin case
15	Opener	Interlocked with the hook shaft eccentric cam
16	Feed mechanism	Wheel feed and driven roller presser intermittent feed
17	Hook drive mechanism	By bevel gear system
18	Drive of the main shaft and hook drive shaft	Timing belt system
19	Lubrication	Semi-automatic
20	Circulation system	By felt
21	Thread trimming mechanism	Side face of the hook oscillation system
22	Disc floating mechanism	By the external magnet
23	Lubrication oil	New Defrix Oil No.1
24	Sewing area	260 mm (10.236") x 285 mm (11.220")
25	Bed size	178 mm (7.008") x 517 mm (20.354")
26	Height of post	179 mm (7.047")
27	Weight of machine head	54 kgf
28	Motor	AC servo motor for heavy-weight materials (K7H)
29	Transmission belt	M type V belt (M40)
30	Auto-lifter (optional)	Driven by external pneumatic system (AK-69A (by knee lifter), AK-69B (interlocked with the foot pedal))
31	Miscellaneous	Provided with safety device

Name of the machine head for the PLW

# PLW-1246

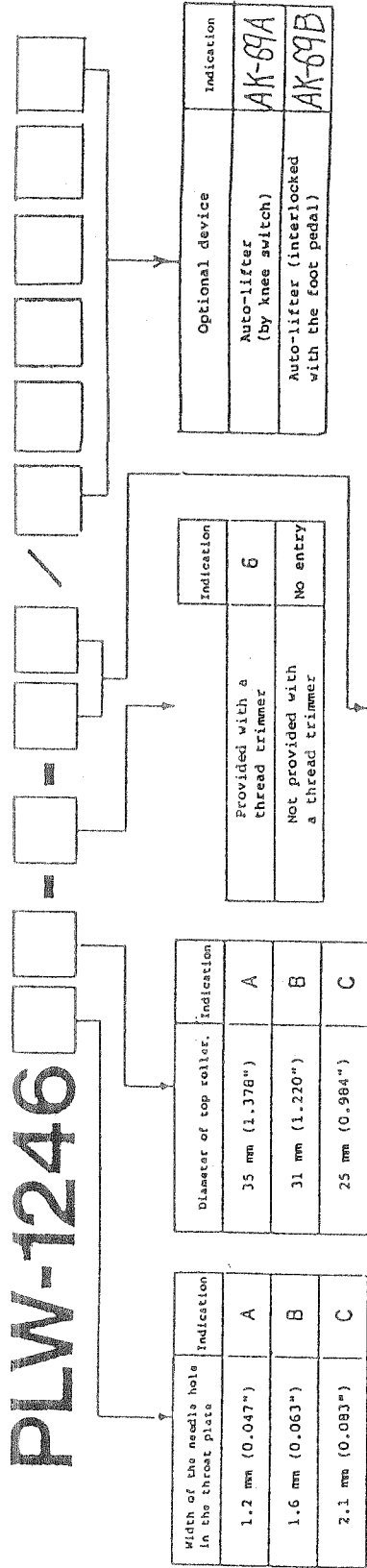

	Indication
Provided with a thread trimmer	6
Not provided with a thread trimmer	No entry

Thread trimming	Indication
Provided with touch-back device	00
Not provided with touch-back device	0B

Table showing the needle number vs the widths of the needle hole in the throat plate

Type	Width of the needle hole in the throat plate	Corresponding count of needle (SCHMETZ 134LR)	Application
A	1.2 mm (0.047")	#65 to #75	For light-weight materials
B	1.6 mm (0.063")	#75 to #110	For medium-weight materials
C	2.1 mm (0.083")	#110 to #125	For heavy-weight materials



STANDARD ADJUSTMENTS

- (1) Needle bar  
 1) Needle entry point

① Lateral direction

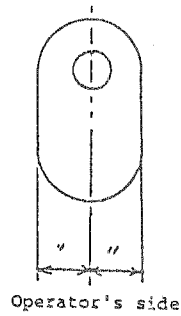

Conditions

\* The needle should enter the center of the needle hole in the throat plate.

- 2) Height of the needle bar

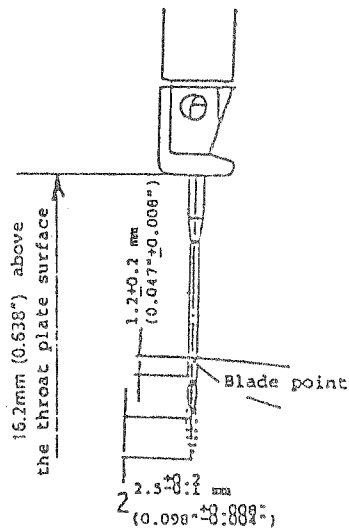

Conditions

\* The needle bar goes up from the lowest position of its stroke by  $2.5^{+0.2}_{-0.1}$  mm ( $0.098^{+0.008}_{-0.004}$ ").

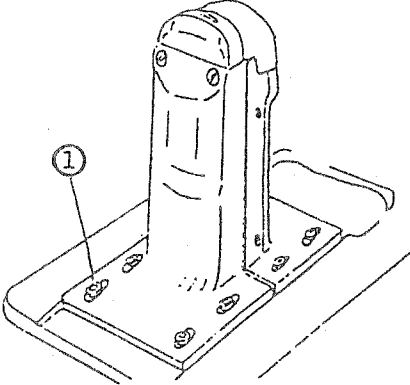
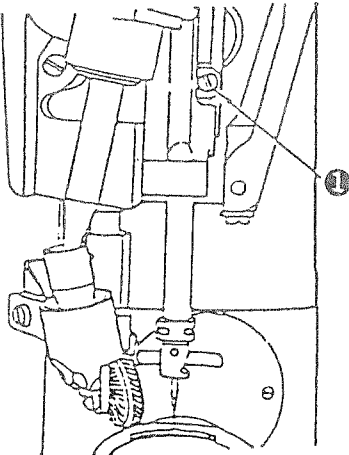

HOW TO ADJUST	RESULTS OF IMPROPER ADJUSTMENT
<p>1) Needle entry point</p> <p>o Lateral direction</p> <ol style="list-style-type: none"> <li>1. Turn the handwheel until the needle bar is carried to its lowest dead point.</li> <li>2. Loosen four screws ①, and adjust so that the needle comes to the position where the specified distance in the lateral direction is obtained.</li> <li>3. After the adjustment, tighten screws ①.</li> </ol> 	<ul style="list-style-type: none"> <li>o Stitch skipping and thread breakage may result.</li> <li>o Loose stitches may result.</li> </ul>
<ol style="list-style-type: none"> <li>1. Turn the handwheel until the needle bar is carried to its lowest dead point.</li> <li>2. Loosen clamping screw ①, and adjust the height of the needle bar by turning the handwheel so that the blade point of the hook is positioned higher than the top end of the needle eyelet by 1.2 mm (0.047") when the needle bar ascends from the lowest position of its stroke by 2.5 mm (0.098"). Now, tighten clamping screw ①.</li> </ol> 	<ul style="list-style-type: none"> <li>o Stitch skipping and thread breakage may result.</li> </ul>

(2) Timing between the needle and the hook

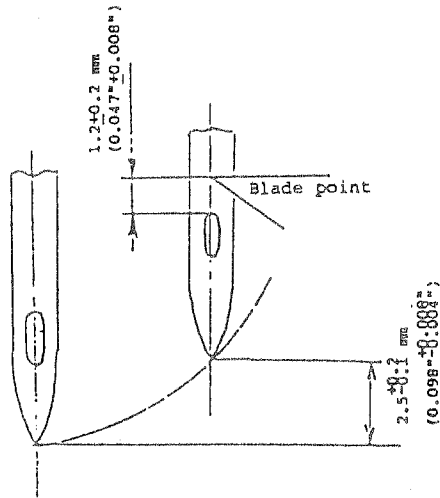

1), 2) Rising amount of the needle and the position of the blade point

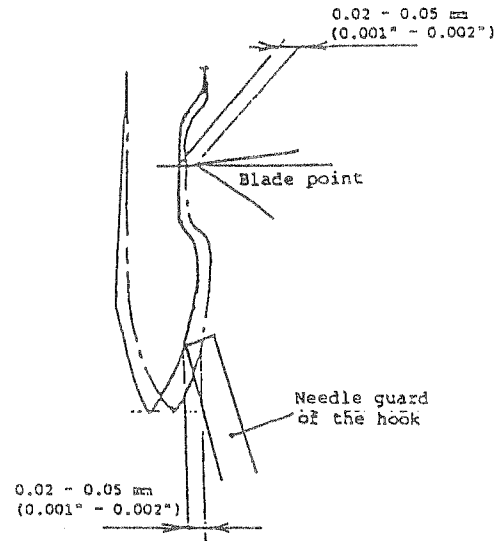

3) Clearance between the needle and the blade point of the hook

Conditions

\* The needle bar goes up from the lowest dead point of its stroke.

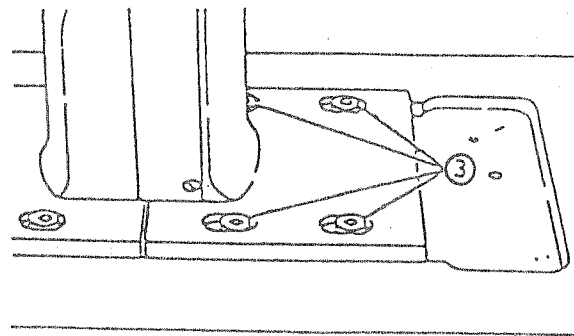
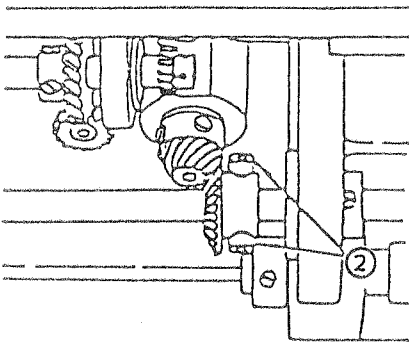

(Bend inward)

(Bend outward)

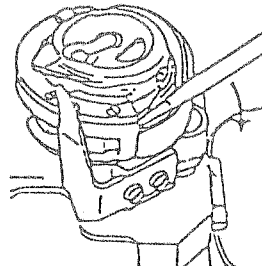
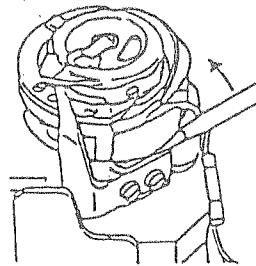

## HOW TO ADJUST

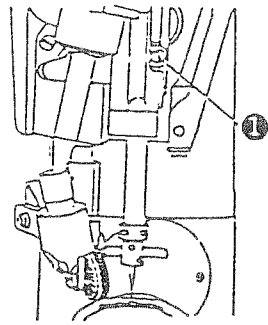

i) Position of the needle and the blade point of the hook

1. Loosen clamping screw ①, and move the needle bar up and down little by little until the specified distance is obtained.
2. Tighten clamping screw ①.

ii) Lifting amount of the needle

1. Loosen three bevel gears ② in the hook driving shaft.
2. Turn the handwheel to make the needle bar ascend from its lowest dead point until the specified distance is reached. Then tighten three screws ②.

iii) Clearance between the needle and the blade point of the hook

1. Loosen four screws ③ in the saddle of the hook driving shaft, and slightly move (arrow direction) the saddle until the specified distance is reached. Then tighten screws ③.

Adjust the clearance between needle and needle guard to the specified distance.

\* Moving the saddle may change the backlash in the gear. Consequently, the bevel gear in the hook driving shaft should be adjusted with regard to the axial direction.  
(Backlash 1.5°)

## RESULTS OF IMPROPER ADJUSTMENT

- o An uneven material feed, stitch skipping, or thread breakage may result.
- o An uneven material feed is eliminated by slightly delaying the hook timing.
- o An isolated idling loop occurs when the hook timing is too early or too late.
- o Defective thread trimming (needle thread is not trimmed) may result.

If the needle contact with needle guard is excessive :

- o The needle may have worn out sooner than normal.
- o Needle breakage may result.

If the needle contact with the needle guard is insufficient :

- o Stitch skipping or thread breakage may result.

Needle bar goes up by 2.5 mm (0.098").

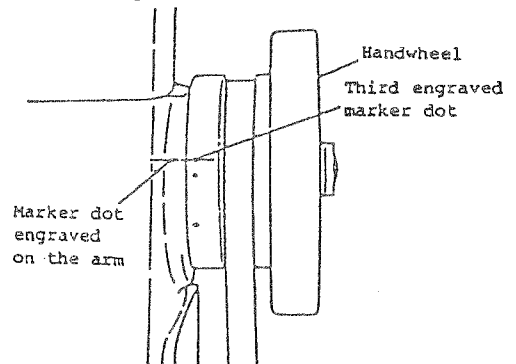

- o As reference of the lifting amount of the needle, the needle goes up by 2.5 mm (0.098") when the third marker dot (no color) engraved on the handwheel is aligned with the marker dot engraved on the arm.

(3) Bobbin case opening lever

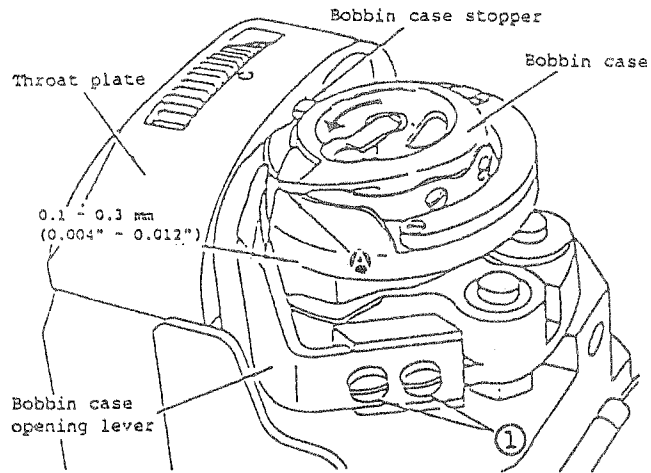

Conditions

- \* The bobbin case opening lever must be at its backward end.
- \* Press the bobbin case stopper toward the groove in the throat plate.

(4) Clearance between the throat plate and the bobbin case stopper

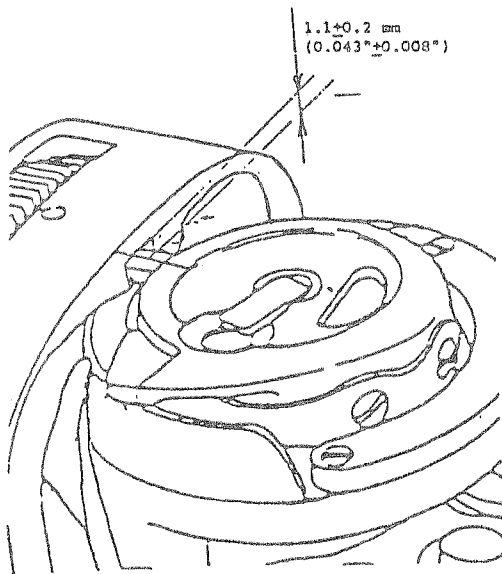

Condition

- \* Clearance between the top end of the bobbin case resting groove on the throat plate and the top face of the bobbin case stopper of the shuttle :  $1.1 \pm 0.2 \text{ mm}$  ( $0.043'' \pm 0.008''$ )

HOW TO ADJUST	RESULTS OF IMPROPER ADJUSTMENT
<ol style="list-style-type: none"> <li>1. Turn the handwheel toward the operator so that the bobbin case opening lever reaches its backward end.</li> <li>2. Turn the bobbin case in the direction opposite to the normal rotational direction of the hook (in the direction of the arrow in the figure) so that the bobbin case stopper is pressed against the rib on the throat plate.</li> <li>3. Loosen two screws ①, and adjust the clearance between the bobbin case opening lever and protruding section ② of the bobbin case to the specified distance.</li> <li>4. After the adjustment, tighten two screws ①.</li> </ol>	<p>If the clearance is too large :</p> <ul style="list-style-type: none"> <li>o Looping or an isolated idling loop may result.</li> </ul> <p>If the clearance is too small :</p> <ul style="list-style-type: none"> <li>o The hook breakage may result.</li> </ul>

<ol style="list-style-type: none"> <li>1. Remove the throat plate.</li> <li>2. Remove the bobbin case opening lever.</li> <li>3. After the thread path holder has been removed, remove the inner hook.</li> <li>4. Loosen screw ①, and remove the hook.</li> <li>5. Select appropriate spacer ② for adjusting the height of the hook, and adjust the clearance. (Refer to the list of spacers given in "5." on page 35.)</li> <li>6. After making the adjustment, confirm the standard adjustment value described in the "Timing between the needle and the hook" on page and the "bobbin case opening lever" on page , and then adjust the clearance again.</li> </ol>	<p>If the clearance is too great :</p> <ul style="list-style-type: none"> <li>o The inner hook may come off the throat plate.</li> </ul> <p>If the clearance is too small :</p> <ul style="list-style-type: none"> <li>o Loose stitches (isolated idling loops) may result.</li> </ul>
---	--

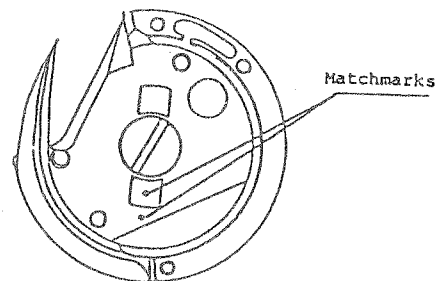
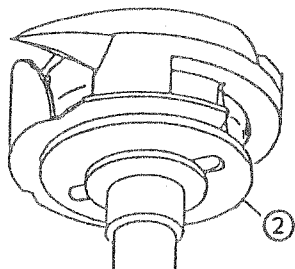
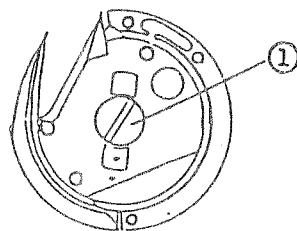

- o When setting the hook in position, be sure to align the matchmark on the hook with the matchmark on the hook driving shaft.

(5) Timing of the cloth feed movement

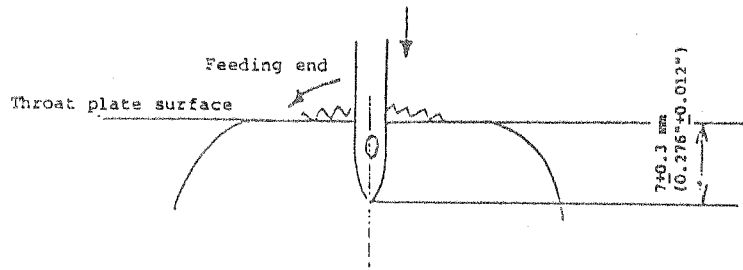

Condition

- \* When the needle is descending, the roller should stop feeding when the tip of the needle comes down  $7 \pm 0.3 \text{ mm}$  ( $0.276 \pm 0.012 \text{ inches}$ ) below the throat plate surface.

(6) Height of the bottom roller

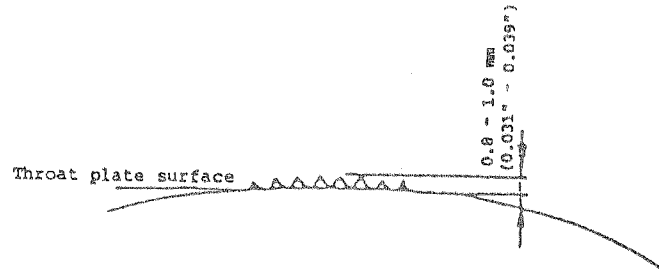

Condition

- \* The top end of the feed dog protrudes 0.8 to 1.0 mm ( $0.031 \text{ inches}$  to  $0.039 \text{ inches}$ ) from the surface of the throat plate.

HOW TO ADJUST	RESULTS OF IMPROPER ADJUSTMENT
---------------	--------------------------------

1. Set the feed amount to the maximum value (4.5 mm (0.177")).
2. Loosen two screws ①, and temporarily tighten them.
3. Turn the handwheel toward the operator to make the needle come down until the tip of the needle is  $7 \pm 0.2$  mm ( $0.276 \pm 0.008$ ") below the throat plate surface. Now stop turning the handwheel.
4. Keeping the handwheel at that position, feed adjuster unit toward the operator so that the feeding arm is fully moved in the direction of the arrow until it will go no further. Now tighten screw ①.

\* When the feed timing has been changed, be sure to adjust the position of the scale plate.

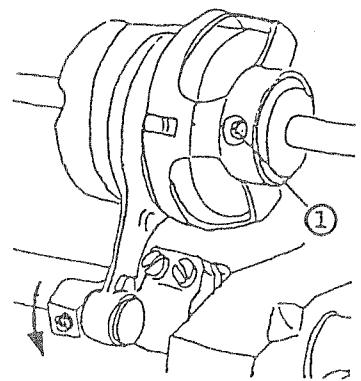

If the feed timing is too early:

- o Loose stitches may result.

If the feed timing is too late:

- o Loose stitches may result.
- o If the timing of the cloth feed movement is excessively delayed, the needle might break.

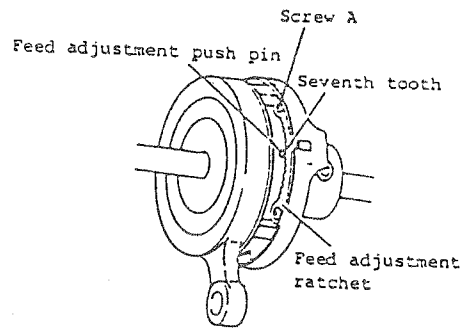

- o As reference of the feeding amount, the feed pitch indicated on the scale plate will be "3" when the feed adjustment push pin is set to the seventh tooth of the feed adjustment ratchet (taking screw A as reference).

1. Loosen two screws ① and remove cover ②.
2. Loosen screws ③ and ④, and adjust the height of the bottom roller to the specified value by turning height adjustment screw ⑤.
3. After making the adjustment, tighten screws ④ and ③ in the written order.

\* When the bottom of the tooth of the bottom roller is aligned with the top surface of the throat plate, the height of the bottom roller will be approximately 1.0 mm (0.039").

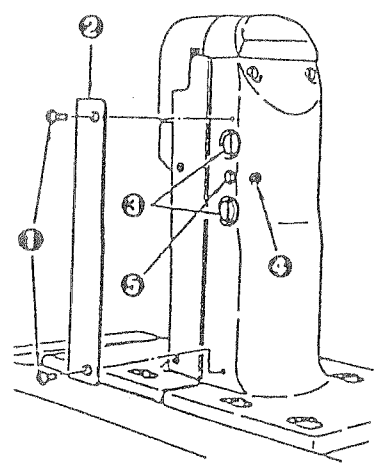

If the bottom roller is positioned too high :

- o An uneven material feed, stitch skipping, or thread breakage may result.

If the bottom roller is positioned too low :

- o The material will not be fed smoothly.

\* When sewing light-weight material, sewing will be facilitated with the bottom roller positioned comparatively low.

(7) Position of the top roller

1) Longitudinal direction

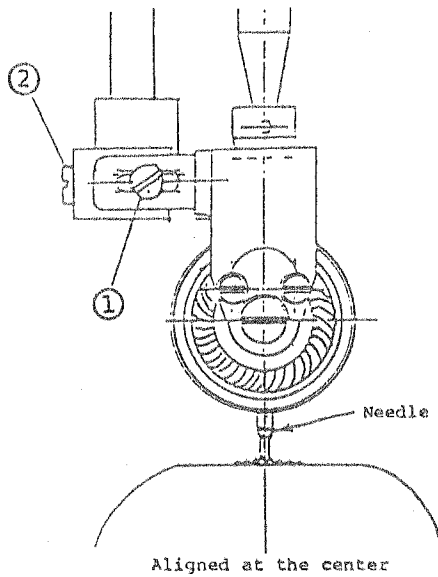

2) Lateral direction

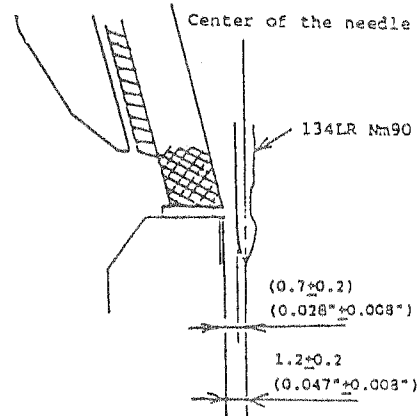

Condition

\* Needle : SCHMETZ 134LR Nm90

Conditions

\* The center of the needle is aligned with the center of the top roller when the needle bar is in the lowest position of its stroke.

(8) Adjusting the top feed amount

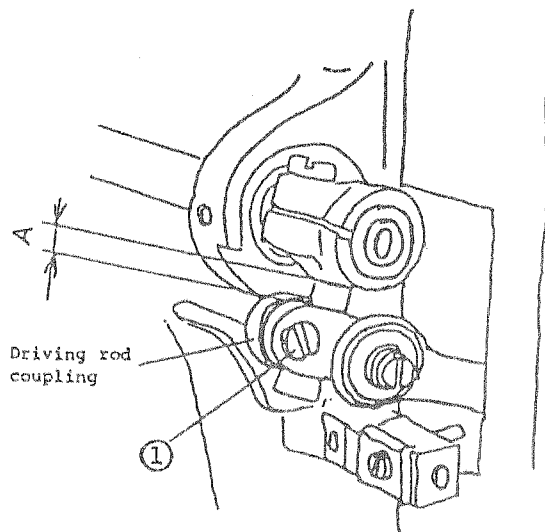



Conditions

\* Feed amount : 3.0 mm (0.118")

\* The feed amount of the bottom roller and the feed amount of the top roller should be the same.

\* Standard adjustment value of distance A :  $4 \pm 0.2$  mm ( $0.157'' \pm 0.008''$ )

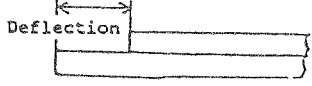

HOW TO ADJUST	RESULTS OF IMPROPER ADJUSTMENT
<p>i) Longitudinal direction</p> <ol style="list-style-type: none"> <li>1. Turn the handwheel toward the operator to make the needle bar come down to its lowest dead point.</li> <li>2. Loosen screw (1), and adjust the position of the top roller so that the center of the top roller is aligned with the center of the needle.</li> <li>3. Tighten screw (1).</li> </ol> <p>ii) Lateral direction</p> <ol style="list-style-type: none"> <li>1. Turn the handwheel toward the operator to make the needle bar to come down to its lowest dead point.</li> <li>2. Loosen screw (2), and adjust the clearance between the top roller and the needle to the specified value.</li> <li>3. After making the adjustment, tighten screw (2).</li> </ol> <p>* Be sure to confirm that there is a clearance between the needle clamp holder and the top roller when the presser lifter is raised with the needle bar in its lowest dead point.</p>	<ul style="list-style-type: none"> <li>o Stitch failure may result.</li> <li>o If the top roller is too close to the operator, stitch skipping may result at the sewing start.</li> <li>o If stitch skipping at the sewing start or needle thread remains at the sewing start when using tetron thread of #40, move the top roller to its backward end position and set the remaining length of needle thread to 50 to 55 mm (1.969" to 2.165"). This will reduce the frequency of the said trouble.</li> </ul> <p>If the clearance is too large :</p> <ul style="list-style-type: none"> <li>o Stitch skipping or thread breakage may result.</li> </ul> <p>If the clearance is too small :</p> <ul style="list-style-type: none"> <li>o Top end of the roller may come in contact with the needle.</li> <li>o Thread breakage may result</li> </ul>
<ol style="list-style-type: none"> <li>1. Set the feed amount to 3.0 mm (0.118").</li> <li>2. Sew the workpieces, and compare the entire sewing length of the two plies of the workpieces finished.</li> <li>3. Loosen clamping screw (1), and increase distance A to increase the top feed amount or decrease distance A to decrease it.</li> <li>4. After making the adjustment, tighten screw (1).</li> </ol> <p>* Take care not to allow the driving rod coupling is tilted against the front arm of the presser foot driving shaft.</p>	<p>If the top feed amount is larger than the bottom feed amount :</p>  <p>The sewing product will warp in the direction of the arrow.</p> <p>If the top feed amount is smaller than the bottom feed amount :</p>  <p>The sewing product will warp in the direction of the arrow.</p>

(9) Lower clutch

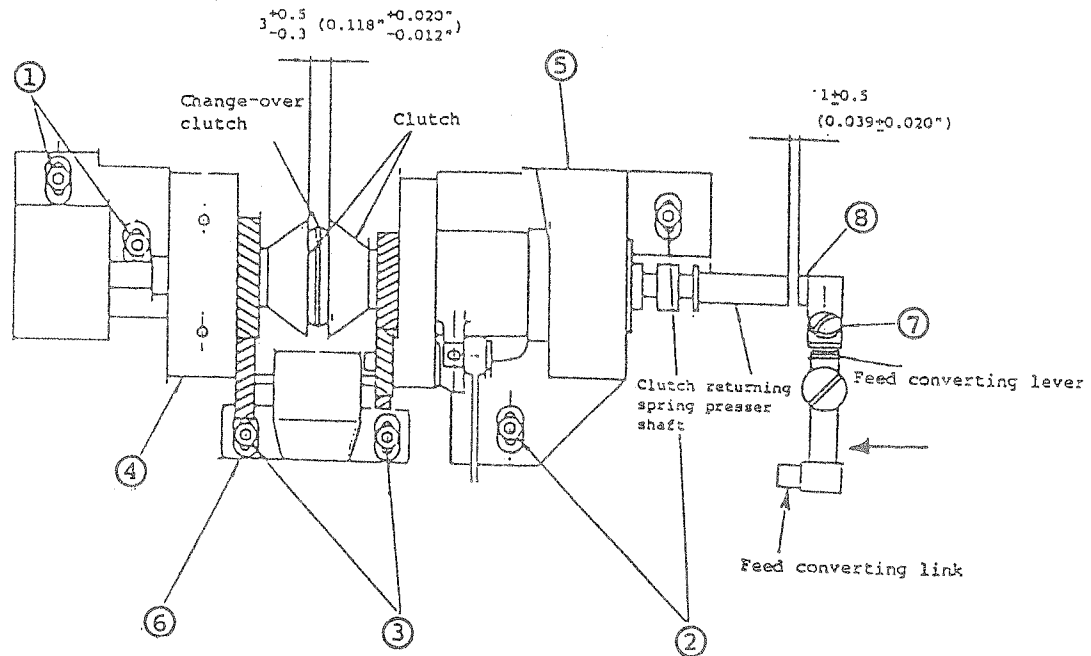

Conditions

\* Clearance in the clutch:  $3^{+0.5}_{-0.3}$  mm (0.118"  $^{+0.020}_{-0.012}$ )

\* Clearance between the feed converting lever and the clutch returning spring:  $1^{+0.5}$  mm (0.039"  $^{+0.020}$ )

HOW TO ADJUST	RESULTS OF IMPROPER ADJUSTMENT
<p>1) Clearance in the lower clutch</p> <ol style="list-style-type: none"> <li>1. Loosen screws ①, ② and ③.</li> <li>2. Temporarily tighten screw ①.</li> <li>3. Adjust the clearance in the clutch to the specified value by moving base ⑤. Then temporarily tighten screw ②.</li> <li>4. Move base ⑥, and let the gear of base ⑥ engage with the gears of bases ④ and ⑤. Then temporarily tighten screw ③.</li> <li>5. Turning the handwheel, press the reverse feed lever several times and confirm that the lower roller normally rotates both in the normal direction and in the reverse direction.</li> <li>6. After the confirmation, tighten screws ①, ② and ③.</li> </ol> <p>(Caution)</p> <ul style="list-style-type: none"> <li>* If the axial center of base ④ is not align with that of base ⑤, the machine may fail to feed normally.</li> <li>* If the backlash of the gear is excessively eliminated, the clutch may fail to actuate normally.</li> </ul>	<p>If the clearance is too small:</p> <ul style="list-style-type: none"> <li>* Change-over clutch may fail to separate. As a result, the reverse feed mechanism may not actuate.</li> </ul> <p>If the clearance is too great:</p> <ul style="list-style-type: none"> <li>* Change-over clutch may fail to come in contact with the clutch. As a result, the reverse feed mechanism may not actuate.</li> </ul>
<p>2) Clearance between the clutch returning spring pressing shaft and the feed converting lever adjustment screw</p> <ol style="list-style-type: none"> <li>1. Loosen screw ⑦.</li> <li>2. Press the feed converting lever against the feed converting link (in the direction of the arrow in the figure), and adjust the clearance between the clutch returning spring pressing shaft and the end face of screw ⑧ in the top end of the feed converting lever to the specified value by turning screw ⑧.</li> <li>3. After making the adjustment, tighten screw ⑦.</li> </ol>	<p>If the clearance is too small:</p> <ul style="list-style-type: none"> <li>* Defective performance of the normal feed mechanism may result.</li> </ul> <p>If the clearance is too large:</p> <ul style="list-style-type: none"> <li>* Defective performance of the reverse feed mechanism may occur.</li> </ul>

(10) Timing of main shaft vs. intermediate shaft vs. hook driving shaft (How to install the timing belt)

If the belt is removed during machine disassembly or on other occasions, re-install the timing belt in according with the following figure.

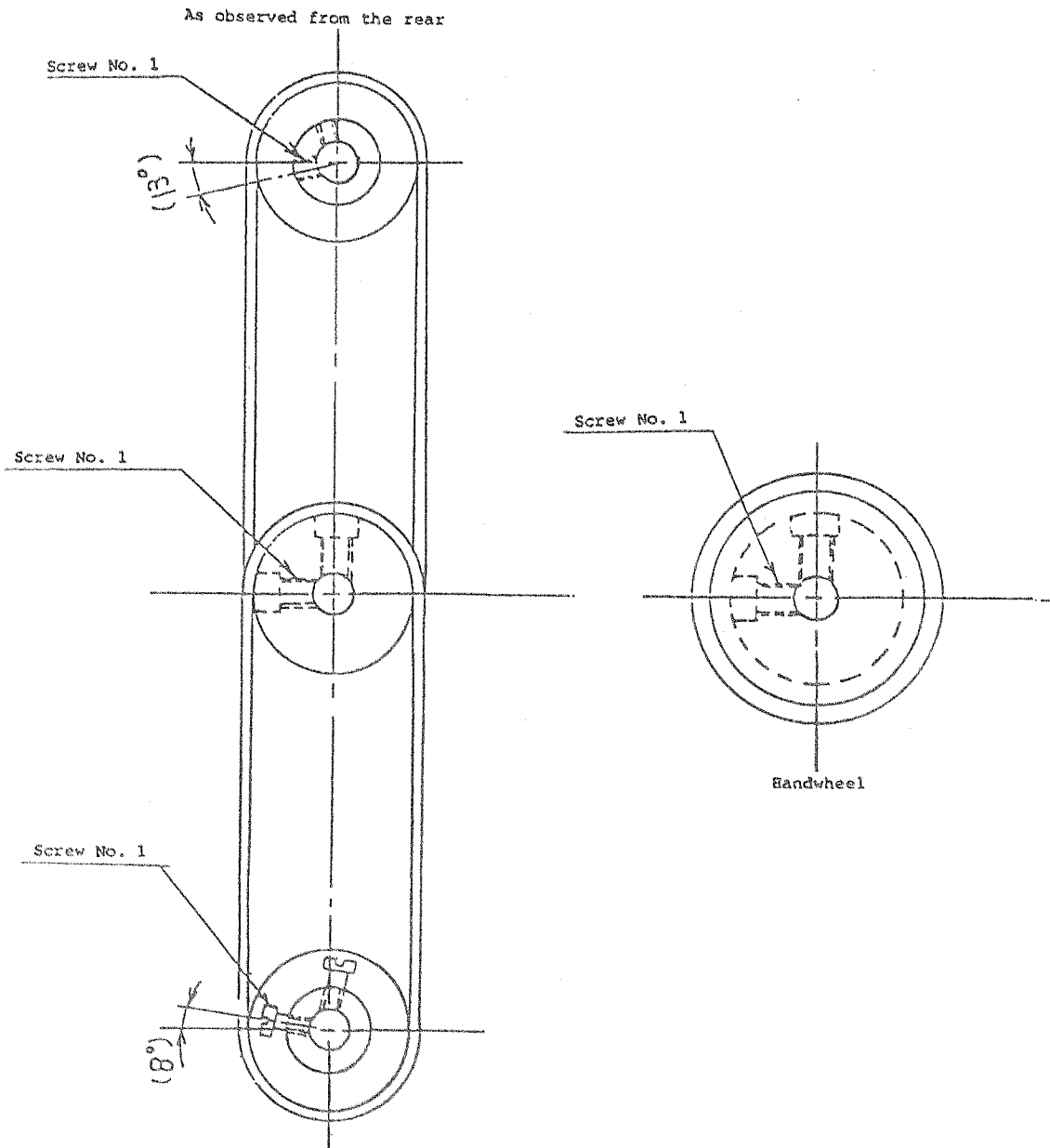

The teeth of the sprocket wheel are spaced at every 30° angle increase so use the teeth as an angle guide indicator.

HOW TO ADJUST	RESULTS OF IMPROPER ADJUSTMENT
<p>i) Main shaft vs. intermediate shaft (how to install the upper timing belt)</p> <ol style="list-style-type: none"> <li>1. Turn the main shaft toward the operator until the needle bar ascends from its lowest dead point by <math>9 \pm 0.2</math> mm (<math>0.354 \pm 0.008</math>").</li> <li>2. Install the upper timing belt so that the screw No. 1 on the handwheel comes just in front of the operator.</li> </ol> <p>ii) Intermediate shaft vs. hook driving shaft (how to install the lower timing belt)</p> <ol style="list-style-type: none"> <li>1. Turn the handwheel toward the operator until the screw No. 1 on the handwheel comes just in front of the operator. Now stop turning the handwheel.</li> <li>2. Install the lower timing belt so that the screw No. 1 in the lower sprocket almost faces toward the operator (<math>8^\circ</math>).</li> </ol>	<p>o If the belt is improperly installed, the value indicated on the scale plate of the handwheel will be different from the actual feed amount of the sewing machine.</p>

(11) Safety mechanism

1) Releasing the safety mechanism

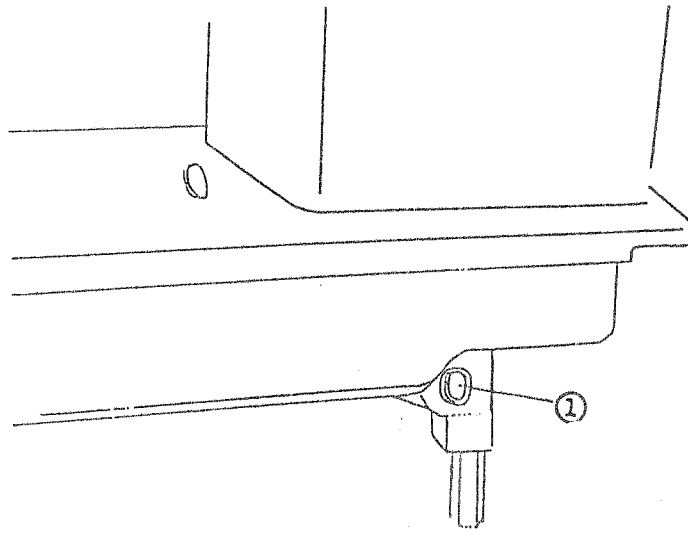

2) Adjusting the safety mechanism

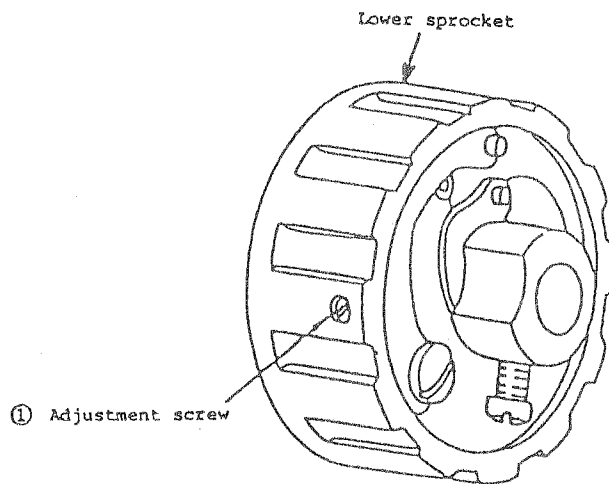

HOW TO ADJUST	RESULTS OF IMPROPER ADJUSTMENT
<p>1) Releasing the safety mechanism</p> <ol style="list-style-type: none"> <li>1. Tilt the sewing machine head.</li> <li>2. Turn the handwheel in the reverse direction strongly with the safety mechanism push-button ① held down.</li> <li>3. Keep turning the handwheel until it clicks.</li> <li>4. Make sure that the handwheel is set in position and is ready to start. (Turning the handweel toward the operator will make the feed components or hook move.</li> </ol>	
<p>2) Adjusting the safety mechanism</p> <p>Re-adjust the pressure of the safety mechanism (when it is difficult to release or it is likely to release) following the below-stated steps of procedure.</p> <ol style="list-style-type: none"> <li>1. Remove the lower timing belt.</li> <li>2. Tighten adjustment screw ① will increase the pressure of the safety mechanism, or loosening the screw will decrease it.</li> <li>3. After making the adjustment, install the timing belt. (Refer to "Main shaft vs. intermediate shaft vs. hook driving shaft" on page for how to install the timing belt.)</li> </ol> <p>* The releasing torque of the safety mechanism has been adjusted to 80 kgfcm ± 10 kgfcm</p>	

STANDARD ADJUSTMENTS

(1) Thread trimmer

1) Initial position of the rotary knife

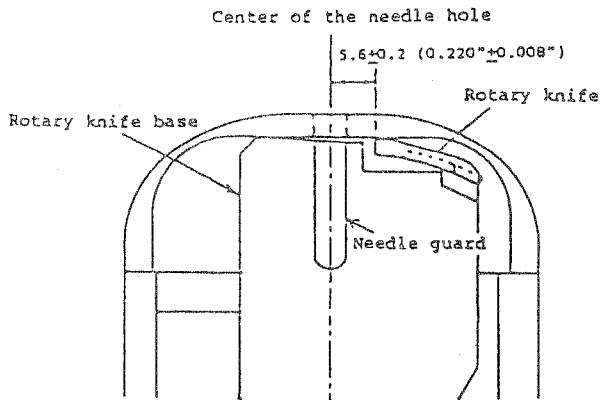

Condition

- \* The initial position of the rotary knife is the position where the distance of  $5.6 \pm 0.2$  mm ( $0.220'' \pm 0.008''$ ) is provided between the top end of the rotary knife and the center of the needle hole.

2) Stroke of rotary knife

Reference for the initial position of the rotary knife and the forward travel end of the rotary knife

\* Initial position :

Distance between the front end of the blade of the counter knife and the top end of the rotary knife. ( $0 \sim 0.3$ mm)

\* Forward travel end :

Clearance between the side face of the rotary knife base and the side face of the feed bar. ( $0.7 \pm 0.2$ mm)

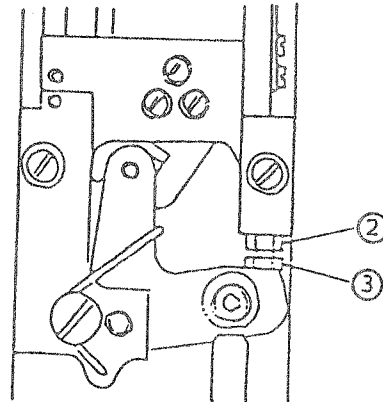
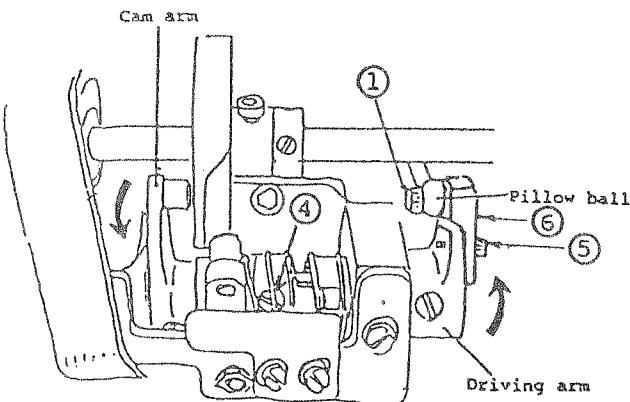
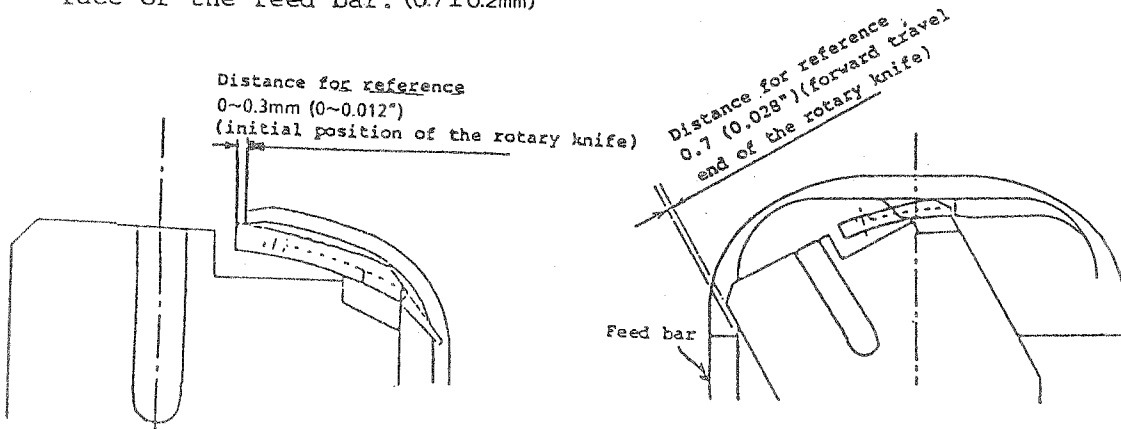

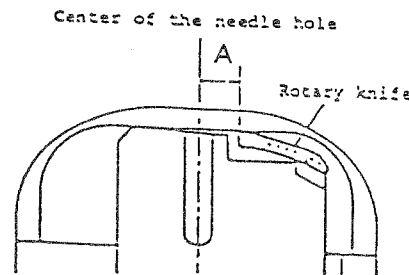
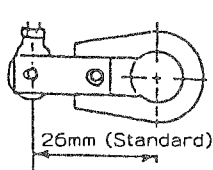
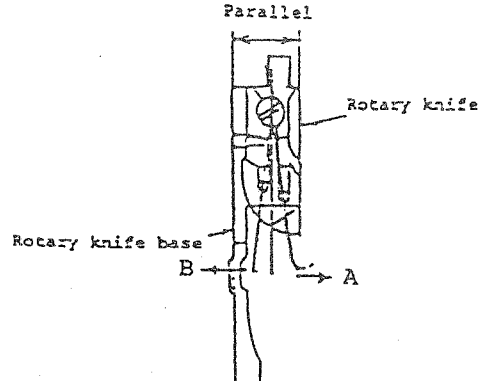

HOW TO ADJUST	RESULTS OF IMPROPER ADJUSTMENT
<ol style="list-style-type: none"> <li>1. Release connection of the driving arm and the pillow ball by loosening screw ①.</li> <li>2. Remove the feed bar from the machine.</li> <li>3. Loosen locknut ②.</li> <li>4. Adjust top end of the rotary knife to the specified value by turning stopper screw ③. Tightening the screw : Distance A in the figure is increased. Loosening the screw : Distance A in the figure is decreased.</li> <li>5. After the adjustment, fix screw ③ using locknut ②.</li> <li>6. Set the feed bar in position. (When setting the feed bar, check the needle entry point.)</li> <li>7. Loosen two screws ④ to make the driving arm to be released.</li> <li>8. Connect the pillow ball and the driving arm.</li> <li>9. Turn the driving arm and the cam arm in the direction of the arrow illustrated in the figure respectively so that a play in each part is eliminated. Then tighten screws ④.</li> </ol> <p>[Point to be confirmed] After the adjustment, make the machine perform thread trimming and check whether the thread trimming mechanism smoothly works. Needle entry should be also confirmed.</p>	 <p>If distance A is too great :</p> <ul style="list-style-type: none"> <li>o Defective thread trimming (needle thread is not cut, or bobbin thread is not cut) may result.</li> </ul> <p>If distance A is too small :</p> <ul style="list-style-type: none"> <li>o Rotary knife base comes in contact with the feed bar.</li> </ul>
<ol style="list-style-type: none"> <li>1. Make the machine perform thread trimming by hand operated and stop the rotary knife at its forward travel end.</li> <li>2. Loosen screw ⑤ and adjust the distance between the feed bar and the rotary knife base to the specified value by changing position of the adjusting plate ⑥.</li> <li>3. After adjustment, tighten screw ⑤.</li> </ol> 	<p>* If the rotary knife is installed with tilted, defective thread trimming may result. So be careful.</p> 
<ol style="list-style-type: none"> <li>4. Make the machine perform thread trimming by hand operated again, and re-check the position of the forward travel end of the rotary knife base.</li> </ol>	<p>If the rotary knife is installed with tilted in direction A :</p> <ul style="list-style-type: none"> <li>o The rotary knife may come in contact with the inner hook.</li> </ul> <p>If the rotary knife is installed with tilted in direction B :</p> <ul style="list-style-type: none"> <li>o Bobbin thread may fail to be cut.</li> </ul> <p>* If the stroke of the rotary knife is too short:</p> <ul style="list-style-type: none"> <li>o Defective thread trimming (needle thread is not cut, or bobbin thread is not cut) may result.</li> </ul> <p>* If the stroke of the rotary knife is too long:</p> <ul style="list-style-type: none"> <li>o Rotary knife base comes in contact with the feed bar.</li> </ul>

## 2) Position of the thread trimming cam

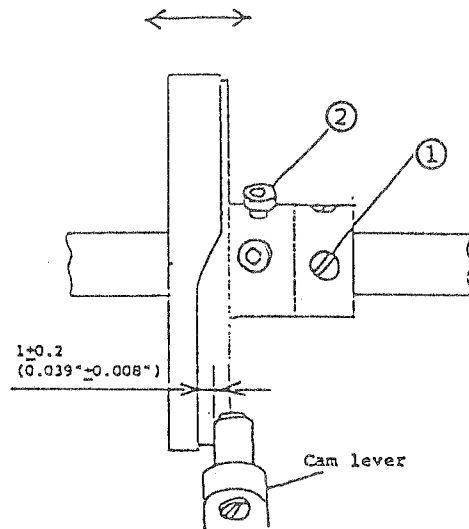

### Condition

- \* The clearance between the periphery of the cam roller shaft and the thread trimming cam should be  $1 \pm 0.2$  mm ( $0.039 \pm 0.008$  inches).

## 3) Thread trimming timing

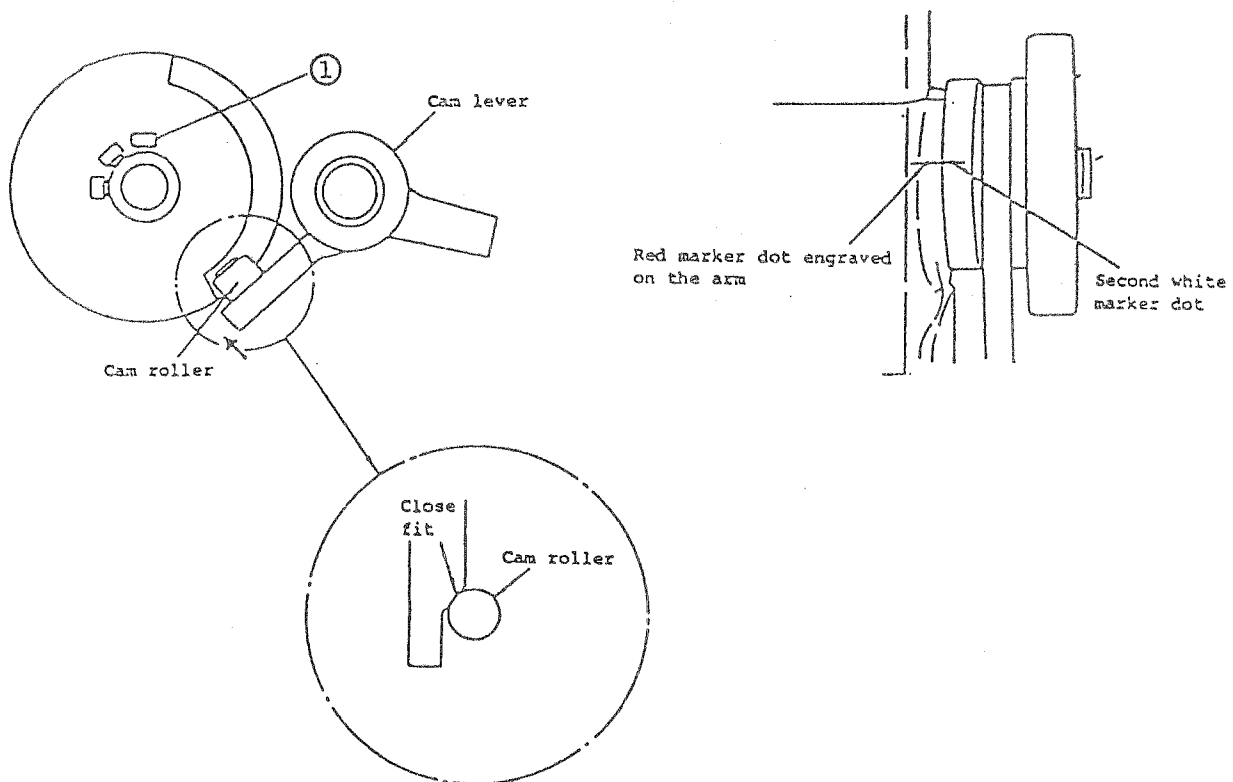

### Condition

- \* When the red marker dot engraved on the arm is aligned with the second white marker dot engraved on the handwheel, the cam roller should be closely fitted to the slope of the periphery of the thread trimming cam. (Degree of angle :  $275^\circ$  when the highest dead point of the needle bar is taken as  $0^\circ$ .)

HOW TO ADJUST	RESULTS OF IMPROPER ADJUSTMENT
<ol style="list-style-type: none"> <li>1. Loosen two screws ① .</li> <li>2. Loosen screw ② .</li> <li>3. Press the cam lever in its rotational direction. At this time, adjust the clearance between the periphery of the cam roller shaft in the cam lever and the end face of the thread trimming cam to the specified value by sliding the thread trimming cam in the lateral direction. Then temporarily tighten screw ② .</li> <li>4. Closely fitting the thrust collar to the end face of the boss in thread trimming cam, tighten screws ① .</li> </ol> <p>* Securely tighten screw ② in the thread trimming cam when adjusting the timing of thread trimming.</p>	<p>If the clearance is excessive :</p> <ul style="list-style-type: none"> <li>o Defective performance of the thread trimmer may result.</li> </ul> <p>If the clearance is insufficient :</p> <ul style="list-style-type: none"> <li>o Defective performance of the thread trimmer may result.</li> </ul>
<ol style="list-style-type: none"> <li>1. Loosen three screws ① in the thread trimming cam.</li> <li>2. Align the second white marker dot engraved on the handwheel with the red marker dot engraved on the arm.</li> <li>3. Press the cam lever in the direction of the arrow until the slant surface of the thread trimming cam is closely fitted to the periphery of the cam roller. Now tighten three screws ① in the thread trimming cam.</li> </ol>	<p>If the timing of thread trimming is too early :</p> <ul style="list-style-type: none"> <li>o Needle thread may come off the needle eyelet. (Double trimming)</li> </ul> <p>If the timing of thread trimming is too late :</p> <ul style="list-style-type: none"> <li>o Thread may not be properly spreaded.</li> <li>o If the timing is excessively slow, the blade point of the hook may come in contact with the rotary knife base, thereby breaking the blade point of the hook.</li> </ul>

4) Clearance between the periphery of the thread trimming cam and the cam roller

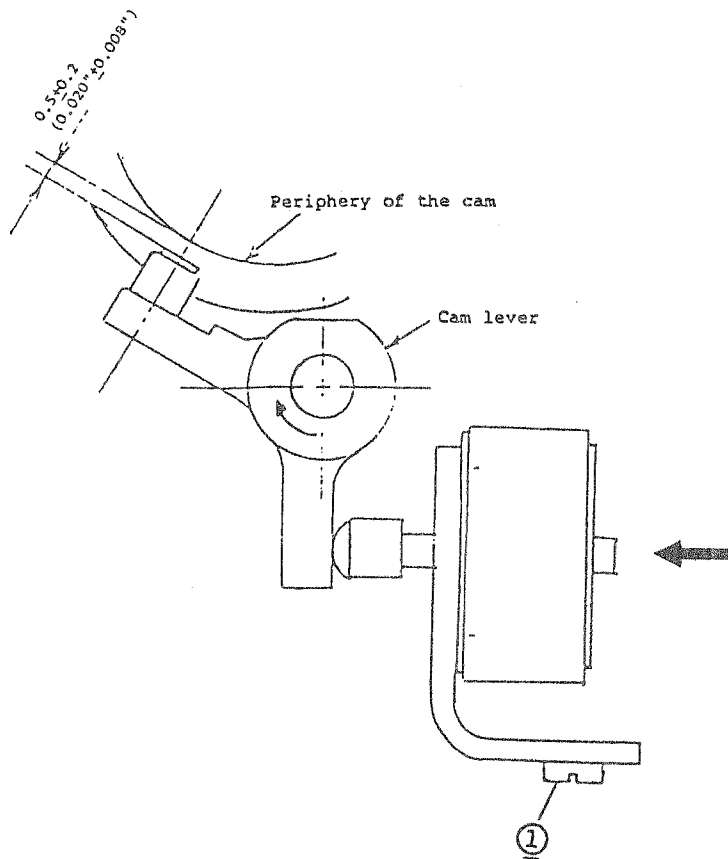

Condition

\* When the thread trimming solenoid actuating stroke is maximized, a clearance of  $0.5 \pm 0.2$  mm ( $0.020 \pm 0.008$  inches) should be provided between the cam roller and the periphery of the cam.

HOW TO ADJUST	RESULTS OF IMPROPER ADJUSTMENT
<ol style="list-style-type: none"> <li>1. Loosen two screws ① in the solenoid mounting base so that they are temporarily fixed.</li> <li>2. Press the armature of the thread trimming solenoid in the direction of the arrow to make the cam roller actuate.</li> <li>3. Once the armature is fully pressed until it will go no further, adjust the position of the solenoid mounting base so that a clearance of the specified value is provided between the periphery of the cam and the end face of the cam roller.</li> <li>4. After making the adjustment, tighten screws ①.</li> </ol>	<p>If the clearance is insufficient :</p> <ul style="list-style-type: none"> <li>o End face of the cam roller may be worn out earlier than usual.</li> </ul> <p>If the clearance is excessive :</p> <ul style="list-style-type: none"> <li>o Defective performance of the thread trimmer may result.</li> </ul>

6) Adjusting the pressure of the counter knife

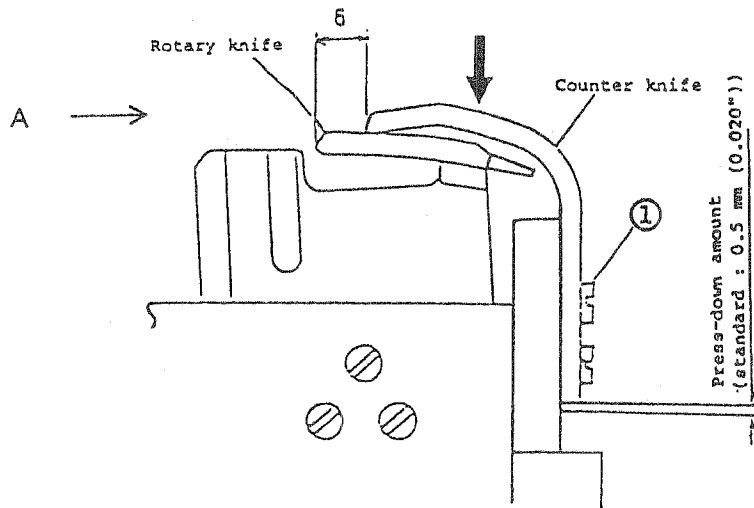

(view from A) : Contact surface of knives.

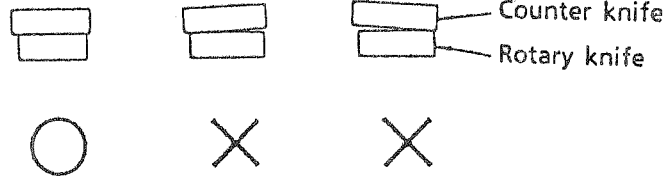

7) Adjusting the clamp spring pressure

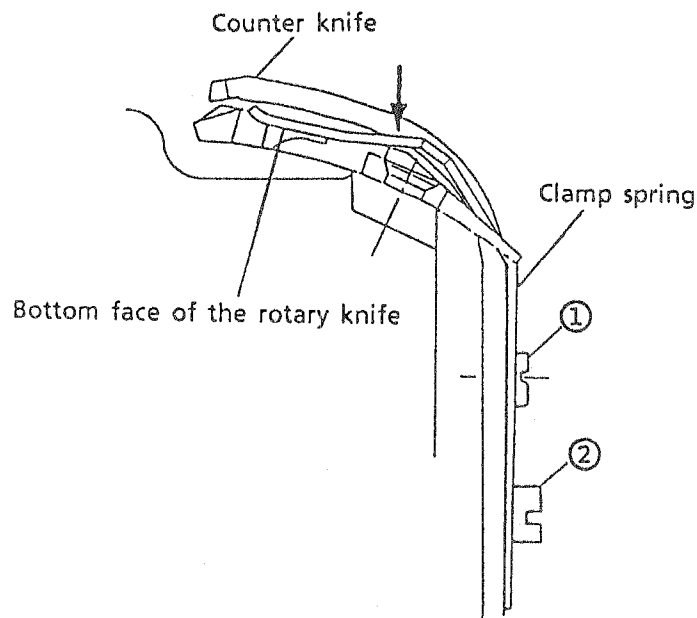

\* Reference value of the clamp spring pressure  
80 gf to 100 gf when using tetron thread #20

HOW TO ADJUST.	RESULTS OF IMPROPER ADJUSTMENT
<p>1. Make the machine perform thread trimming by hand. Then stop the rotary knife when it is 6 mm (0.236") away from the top end of the blade of the counter knife.</p> <p>2. Loosen two screws ① in the counter knife so that they are temporarily tightened.</p> <p>3. Press the counter knife toward the direction of the arrow until the counter knife come down by 0.5 mm (0.020"). Now tighten screws ①. (This is a mere standard adjustment value. Further lower the counter knife if the knife does not cut sharp.)</p> <p>Caution</p> <p>① If the blade plane of the counter knife is tilted with regard to the top surface of the rotary knife, quality of the knife will never be improved how high the knife pressure is increased. So be careful.</p> <p>② The knife pressure is desired to be minimized as long as the knife cuts both needle thread and bobbin thread.</p>	<p>If the knife pressure is inadequate :</p> <ul style="list-style-type: none"> <li>o The knife may fail to cut needle thread and bobbin thread.</li> </ul> <p>If the knife pressure is excessive :</p> <ul style="list-style-type: none"> <li>o The machine may be locked.</li> </ul>
<p>1. Loosen screw ①, ②.</p> <p>2. Press the clamp spring in the direction of the arrow slightly, so that the clamp spring will be contacted to the bottom face of the rotary knife.</p> <p>3. Tighten screw ① temporarily.</p> <p>4. Tighten screw ② firstly and ① secondly.</p> <p>(Caution)</p> <p>Concerning the installation position of the clamp spring in the lateral direction, the clearance between the clamp spring and the groove in the rotary knife should be equal in the left-hand and right-hand sides of the clamp spring.</p> <div data-bbox="243 1596 893 2079" data-label="Diagram"> </div>	<p>If the clamp spring pressure is inadequate :</p> <ul style="list-style-type: none"> <li>o Stitch skipping at the sewing start may result.</li> <li>o Bobbin thread may be loosened at the sewing start.</li> </ul> <p>If the clamp spring pressure is excessive :</p> <ul style="list-style-type: none"> <li>o Clamp spring may break.</li> </ul>

## 8) Automatic reverse feed device

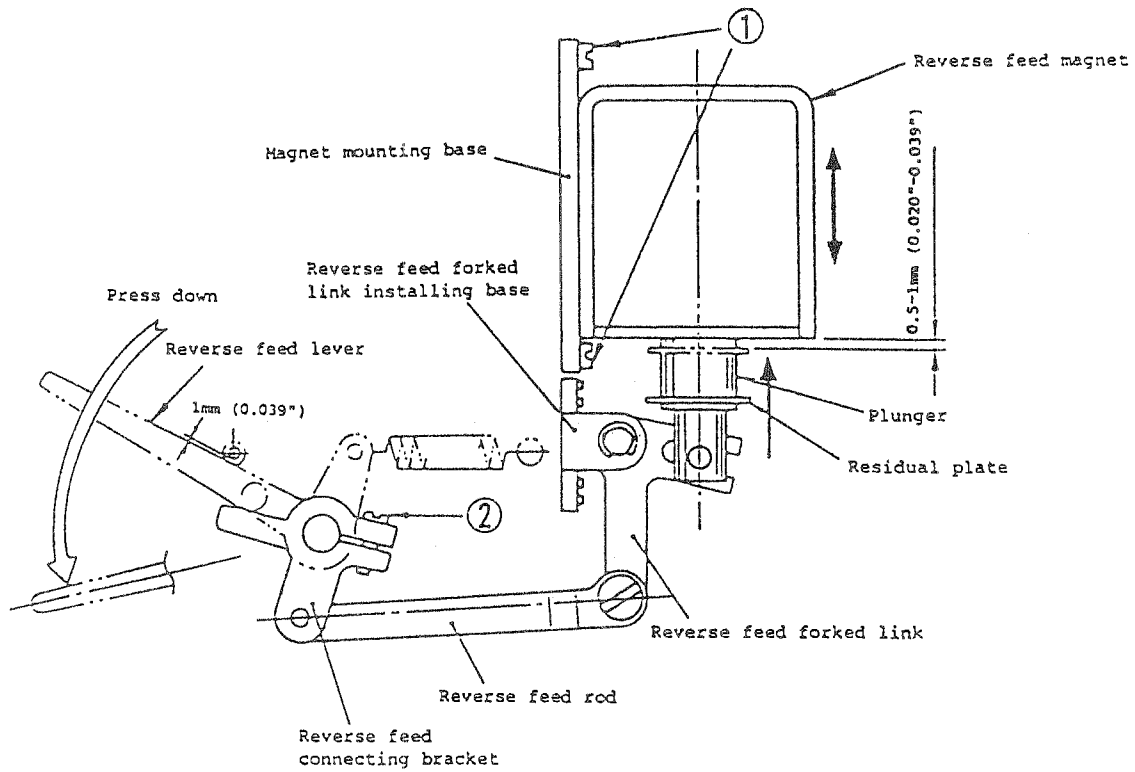

### Condition

\* When pressing the reverse feed lever until it will go no further, a 0.5 to 1 mm (0.020" to 0.039") clearance is obtained between the reverse feed magnet and the plunger residual plate.



HOW TO ADJUST	RESULTS OF IMPROPER ADJUSTMENT
<ol style="list-style-type: none"> <li>1. Loosen screw ① in the magnet mounting base.</li> <li>2. Press the reverse feed lever until it will go no further, and move the magnet mounting base up and down to adjust so that a clearance of 0.5 to 1 mm (0.020" to 0.039") is provided between the residual plate on the plunger and the inside of the reverse feed magnet.</li> </ol>	<p>If the clearance is too large:</p> <ul style="list-style-type: none"> <li>* Attracting force of the magnet will be decreased, and the reverse feed mechanism may not be actuated.</li> </ul> <p>If the clearance is too small:</p> <ul style="list-style-type: none"> <li>* Stitch length at the time of reverse feed stitching may be smaller than the stitch length at the time of normal feed stitching.</li> </ul>

(2) Tension disc floating device

1) Floating amount of the disc

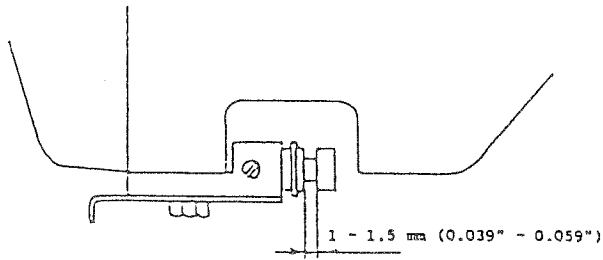

Condition

\* The device works to float the disc as far as 1 to 1.5 mm (0.039" to 0.059").

### HOW TO ADJUST

1. Make the machine perform thread trimming so that the disc is released.
2. Loosen two screws ① in the converter base.
3. Move the converter base in direction A to increase the opening amount, or in direction B to decrease it.
4. After the adjustment, tighten screws ①.

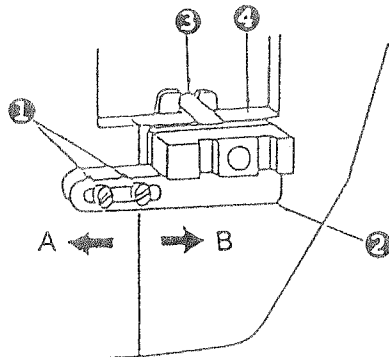

(Caution) Attention should be attached not to allow pin ③ to come into contact with notched surface ④ of the face plate.

- \* (1) After the adjustment, actuate the disc floating device in order to confirm that the disc is completely closed when the machine starts sewing third stitch counting from the sewing start.
- (2) The standard adjustment value of the thread guide holder pressure is 3 to 4 g of passage resistance when using tetron thread #20.
- (3) When using andaria thread, nylon bond thread, tetron thread #40 or the like, it is recommended to increase the holder pressure. This will stabilize the remaining length of the needle thread after thread trimming. Adjust the holder pressure following the procedure stated below. After the adjustment, confirm the floating amount of the disc again.
1. Loosen screw ① in the thread guide shaft.
  2. Move the thread guide shaft in direction A to increase the pressure, or in direction B to decrease it.
  3. After the adjustment, tighten screw ①.

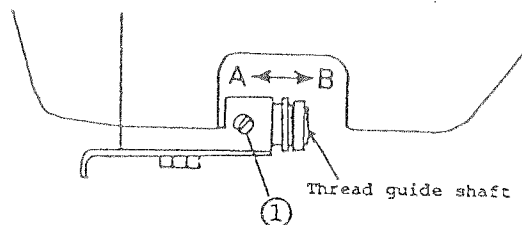

### RESULTS OF IMPROPER ADJUSTMENT

- If the disc is not released enough to float :
- o Stitch skipping at the sewing start may result.
- If the disc is released to float excessively :
- o The disc may fail to close after the actuation. As a result, the needle thread may come off.

STANDARD ADJUSTMENTS

If using andaria thread, nylon bond thread or the like, be sure to carry out the special adjustment stated below. If only the standard adjustment has been made, defective stitches, defective thread trimming may result.

1) When using andaria thread

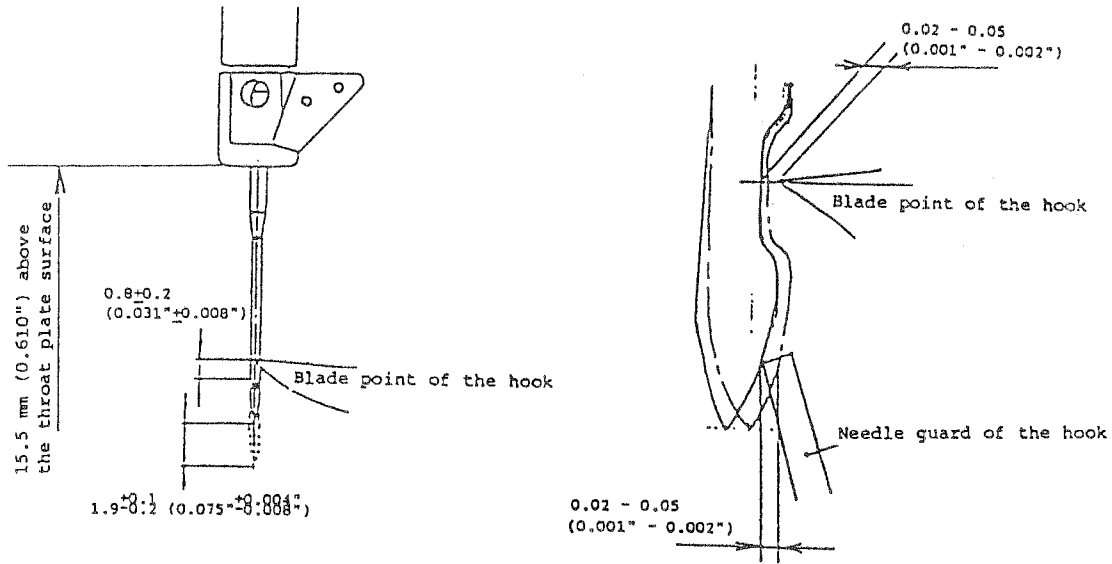

(1) Timing between the needle and the hook

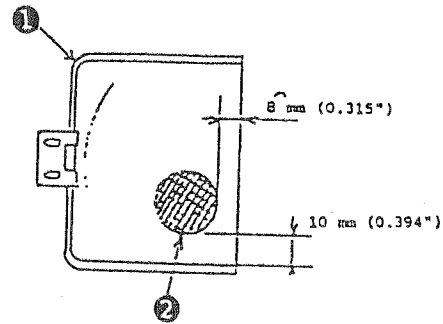
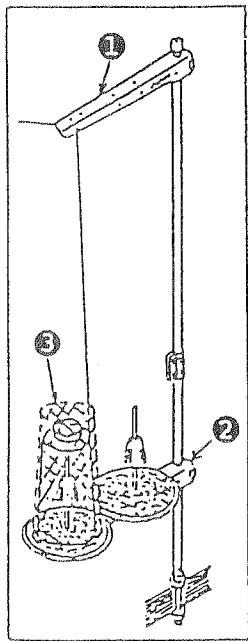

(2) Attaching Velcro

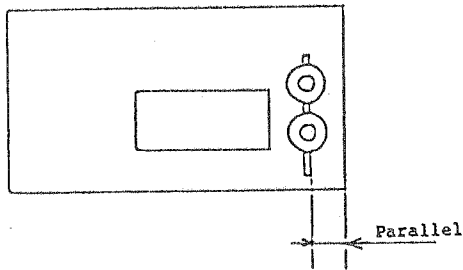

(3) Position of the thread stand and threading the machine head

## HOW TO ADJUST

## RESULTS OF IMPROPER ADJUSTMENT

Thread the machine head in the order as illustrated.  
(Thread take-up lever has two holes. Thread the outside hole.)

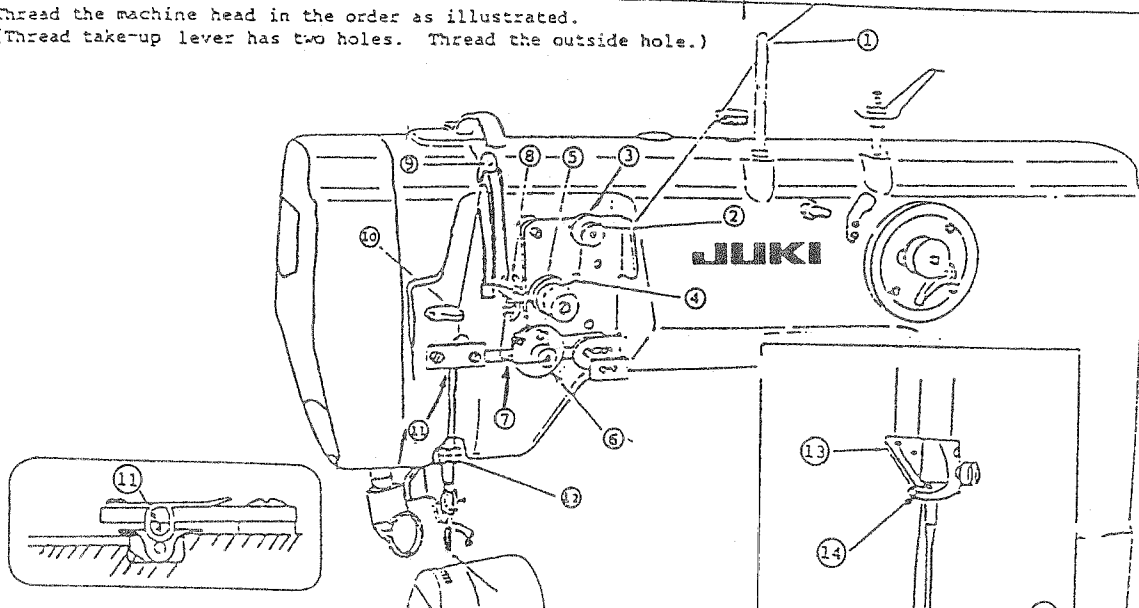

- (1) Timing between the needle and the hook
  1. Replace the needle clamp with the needle clamp supplied with the machine.
  2. Adjust the timing to the standard adjustment value according to the explanation given in "Timing between the needle and the hook" on page . (As reference value of the lifting amount of the needle, the needle should ascend from its lowest dead point by 1.9 mm (0.075") when the yellow marker dot engraved on the handwheel is aligned with the marker dot engraved on the arm.)
- (2) Attaching Velcro
  1. Attach Velcro (2) supplied with the machine onto the reverse face of hook cover (1) to the location indicated by the specified dimensions.
- (3) Position of the thread stand and threading the machine head
  1. Install the thread stand so that it is approximately in parallel to the table.
  2. Install thread stand rod (asm.) (1) and thread stand rod (2) with the distance between them maximized.
  3. Put net (3) over the bobbin winder. Set the net opening above the bobbin winder.
  4. Thread the machine head in the order illustrated in the figure.

- \* The needle thread of the last stitch may become loose at the time of thread trimming. This is caused by the property of the thread.
- \* If the needle thread become loose, increase the bobbin thread tension.

- 2) When using nylon bond thread
  - (1) Position of the thread stand and threading the machine head  
Same as the explanation concerning andaria thread.  
The net, however, is not used.

(Caution)

For the adjustment of timing of the hook, carry out the adjustment procedure same as the

Name of part	Part No.	Engraved mark	Dimensional tolerance
Needle bar frame shaft bushing washer	B1438512A00		1.35 ± 0.05
	B1438512B00 (standard)		1.5 ± 0.05
	B1438512C00		1.65 ± 0.05
Roller inner wheel B spacer	10507903 (standard)		0.4 ± 0.05
	10508802		0.5 ± 0.05
	10508901		0.6 ± 0.05
Hook height adjusting spacer	10573608	A	0.3 ± 0.03
	10573707	B	0.4 ± 0.03
	10573806 (standard)	C	0.5 ± 0.03
	10573905	D	0.6 ± 0.03
	10574002	E	0.7 ± 0.03
Take-up crank spacer	10548501	E	1.0 ± 0.02
	10548600 (standard)	F	1.03 ± 0.02
	10548709	G	1.06 ± 0.02
	10548808	H	1.09 ± 0.02

## 6. LIST OF CONSUMABLES

Name of part	Part No.
Needle (SCHMETZ134LRNm90)	MC2005A0900
Hook (asm.)	10545655
Bobbin	10544708
Rotary knife	10543528
Counter knife	10543619
Clamp spring	10543718

## 7. POINTS TO BE APPLIED WITH LOCKTITE

The following parts are fixed with LOCKTITE 242. If any of these parts is disassembled, be sure to clean the adhering plane using thinner and then thoroughly dry it up. When assembling, be sure to apply the LOCKTITE 242 to the adhering plane.

If the part fixed applying LOCKTITE 242 will not be disassembled, warm the part using a torch lamp or the like. This will help disassemble the part.

(Caution)

It is advisable not to disassemble the following parts.

Take-up crank pin	[Part No. 10524106]
Bobbin case opening lever crank pin	[Part No. B1821051000]
Cam roller shaft	[Part No. 10563401]
Stopper screw	[Part No. SS6110510SP] (to be assembled to the cam arm 10540607)
Locknut in take-up disc floating driving wheel	[Part No. MN6040000SB] (to be assembled to the driving wheel 10565059)

## 8. OTHER SPECIAL INFORMATION

- o Comparison table of SCHMETZ needles and ORGAN needles

Standard needle for this machine is SCHMETZ needles. If using ORGAN needles for the circumstance's sake, apply the followings.

SCHMETZ code	ORGAN code
134LR	PF x 134LR
134(R)	DP x 134 or DP x 5

Comparison table of count of needle

SCHMETZ	Nm	65	70	75	80	85	90	100	110	120	125
ORGAN	#	9	10	11	12	13	14	16	18	19	20

(Caution)

The standard needle for this machine is SCHMETZ's needle. Using a needle other than SCHMETZ needle may impair the stitch quality.

- o How to use the silicon oil tank

If using the silicon oil according to the type of sewing product or thread to be used, install the silicon oil tank as illustrated below.

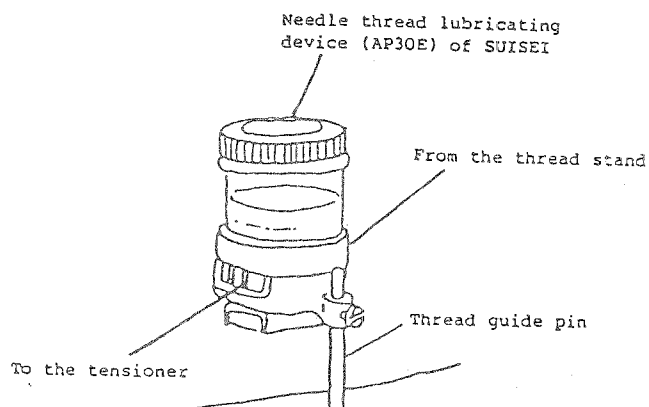

9. TROUBLES IN SEWING OPERATION AND CORRECTIVE MEASURES

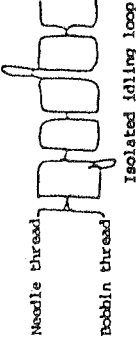
PROBLEM	DESCRIPTION	CAUSE (1)	CAUSE (2)	CORRECTIVE MEASURES
1. Isolated idling loop (loose stitches, looping)	<p>Knotting points of sewing threads abruptly appears on the front side or wrong side of the cloth in the form of loop.</p>  <p>Needle thread</p> <p>Bobbin thread</p> <p>Isolated idling loop</p>	Improper thread tension		Increase the thread tension.
		Improper adjustment of take-up spring.	Stroke of the thread take-up spring is inadequate.	Adjust the stroke to be larger.
			Needle thread tension is insufficient.	Increase the thread tension.
		Stroke of thread take-up lever is too large.		Move the thread guide of the arm upward, thereby decreasing the feed amount of the needle of the thread take-up lever.
		Defective hook components.	Clearance between hook and bobbin case opening lever is too small.	Lower the hook using hook height adjusting spacer.
			Defective hook (thread is caught in the hook).	Replace the hook.
		Defective thread path	Thread path is not finished smoothly.	Finish the thread path appropriately.
			Thread path has scratches on it.	Finish the thread path appropriately.
			Thread path is catchy.	Correct the thread path.



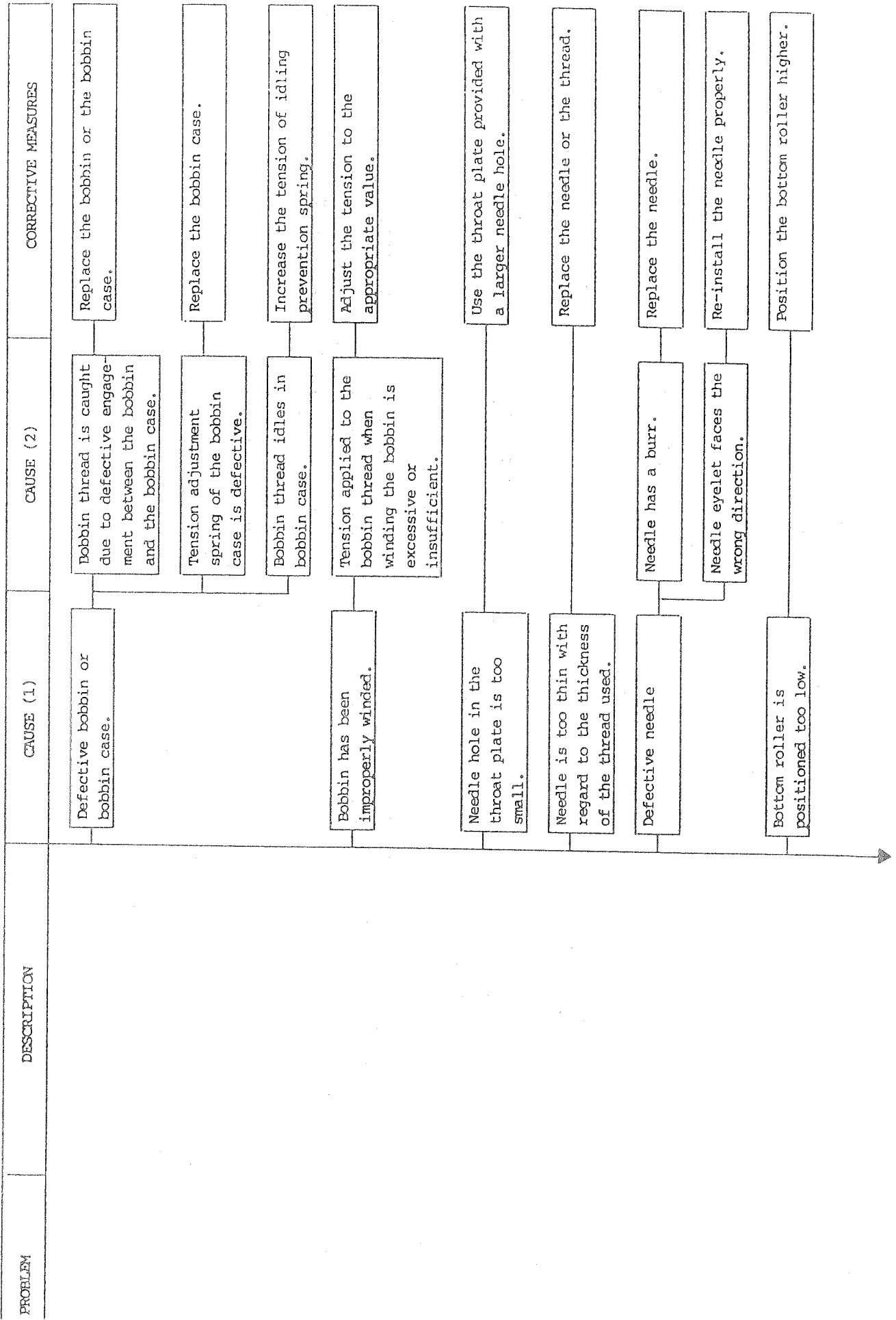

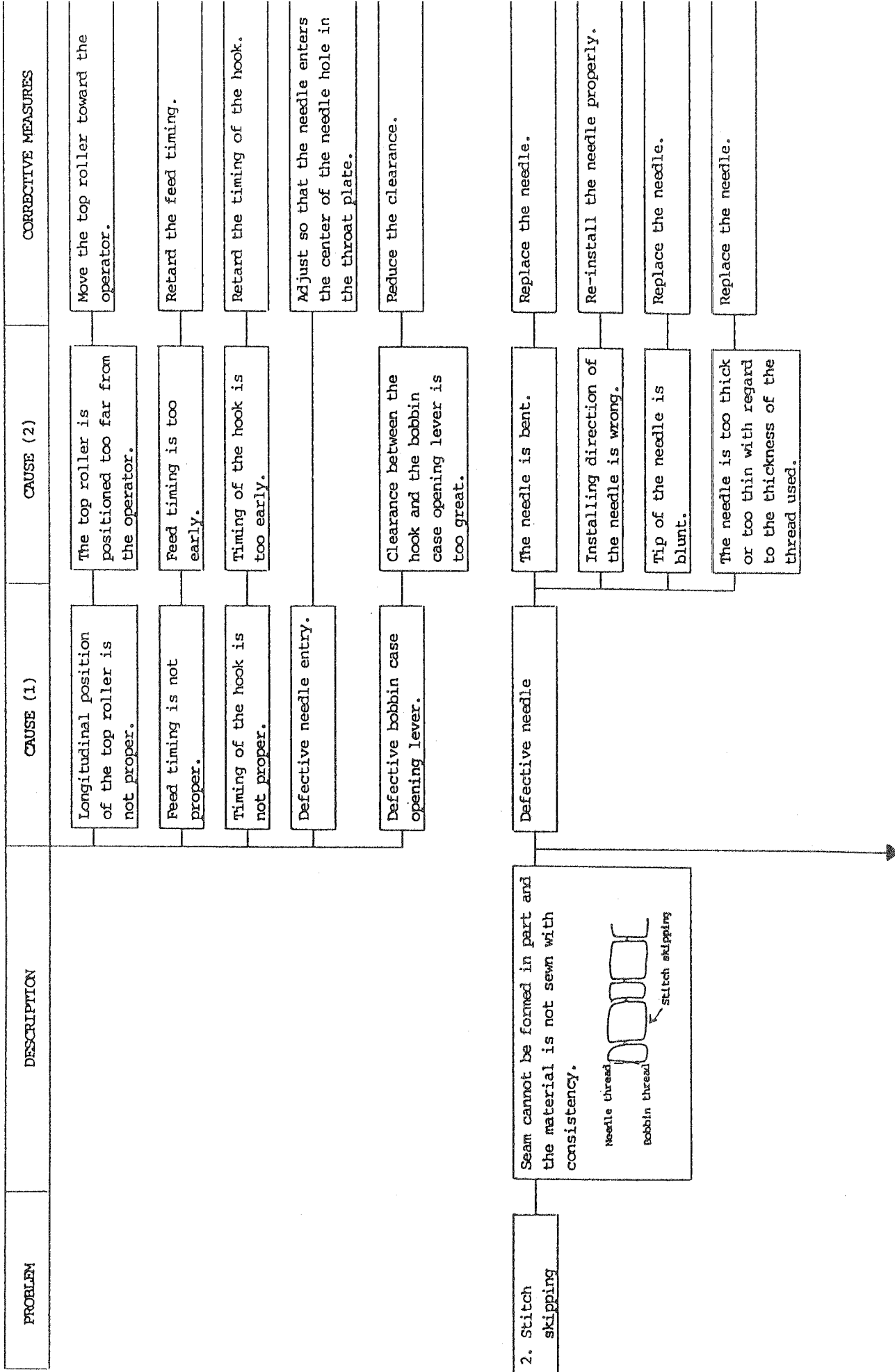

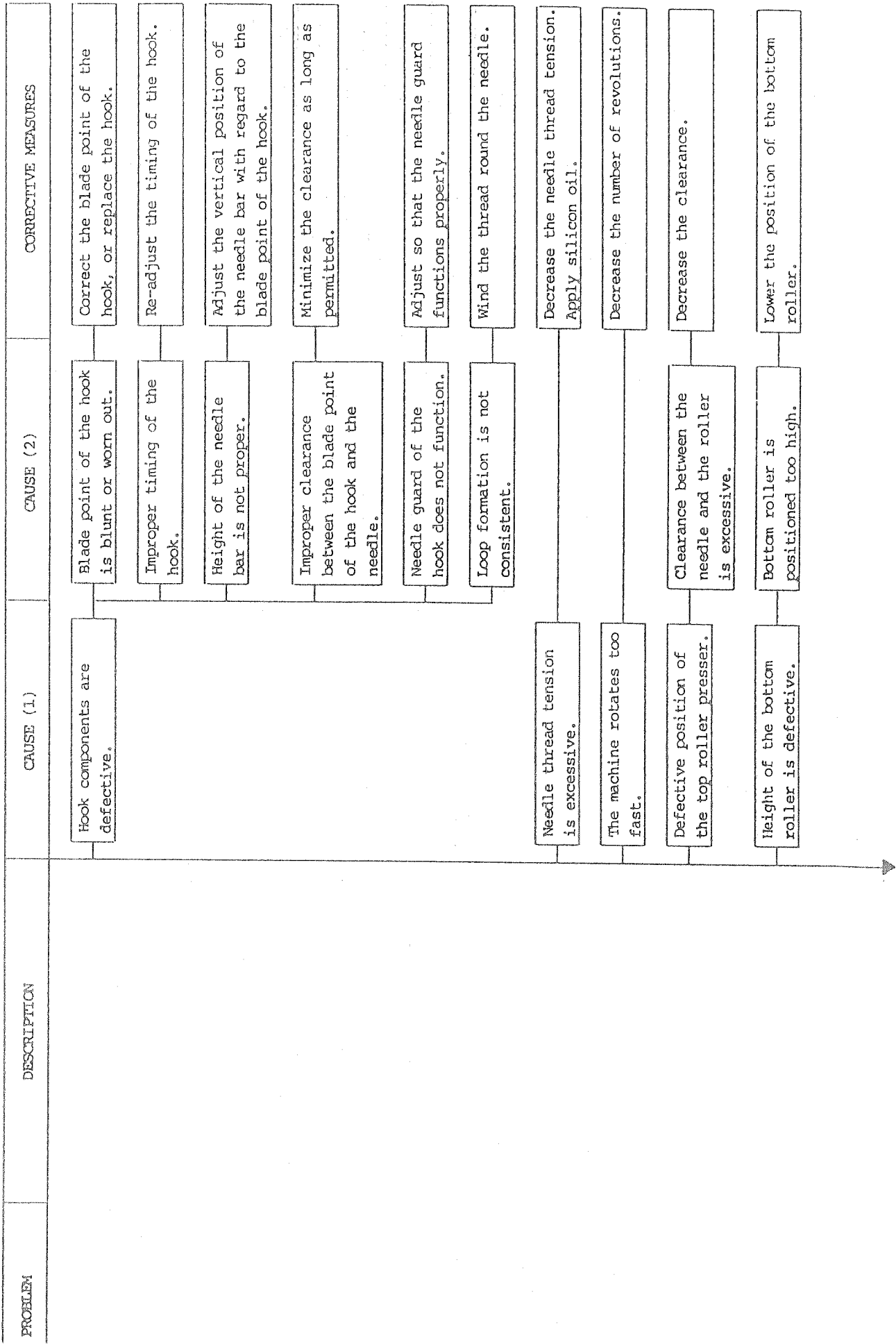

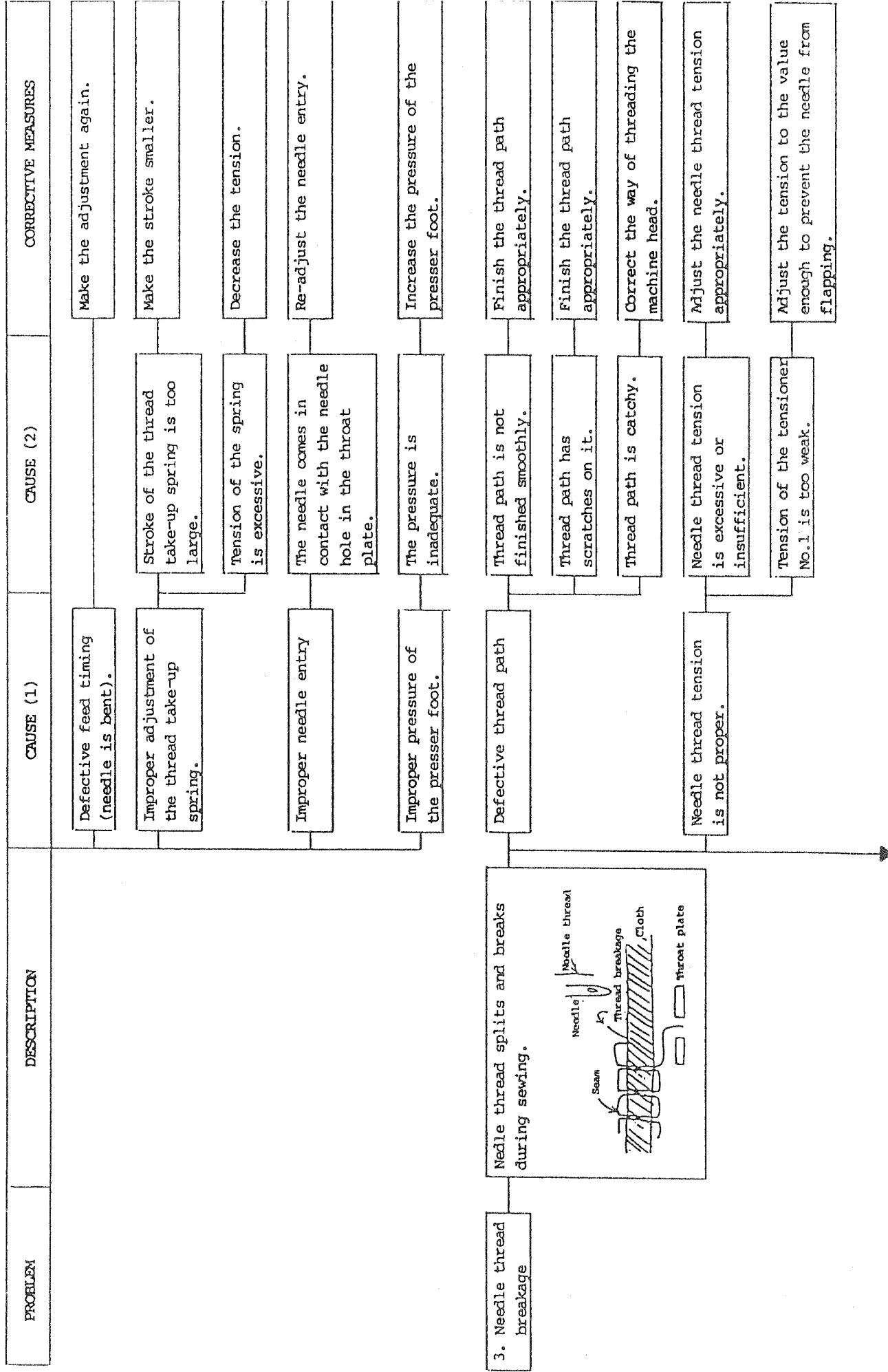

PROBLEM	DESCRIPTION	CAUSE (1)	CAUSE (2)	CORRECTIVE MEASURES
		Defective needle	The needle is bent.	Replace the needle.
			The needle has scratches on the surface.	Replace the needle.
			Tip of the needle is blunt.	Replace the needle.
			Installing direction of the needle is wrong.	Re-install the needle properly.
			The needle is too thick or too thin with regard to the thickness of the thread used.	Replace the needle.
		Hook components are defective.	Thread path in the hook is damaged.	Finish the thread path properly.
			Blade point of the hook is blunt or worn out.	Correct the blade point of the hook, or replace the hook.
			Clearance between the hook and the bobbin case stopper is too narrow.	Widen the clearance so that the thread is fed out smoothly.
			Timing of the hook is too early.	Re-adjust the timing of the hook.
			Clearance in the bobbin case opening lever is excessive.	Re-adjust the clearance.

PROBLEM	DESCRIPTION	CAUSE (1)	CAUSE (2)	CORRECTIVE MEASURES
			The needle comes in contact with the blade point of the hook.	Adjust the relationship between the needle and the blade point of the hook appropriately so that the optimum adjustment value is obtained.
		The needle bar is positioned too low.		Position of the needle bar higher
		The number of revolutions is too high.	Thread breaks due to the heat.	Reduce the number of revolutions.
				Wind thread to the needle.
		Needle-down stop position of the machine is not correct.	Needle-down stop position is reached too late.	Make re-adjustment.
		Pressure of the presser foot is insufficient.	The thread breaks at the overlapped section since the thread is caught there.	Increase the pressure.
		Defective needle entry.	The needle comes in contact with the needle hole in the throat plate.	Make the re-adjustment.

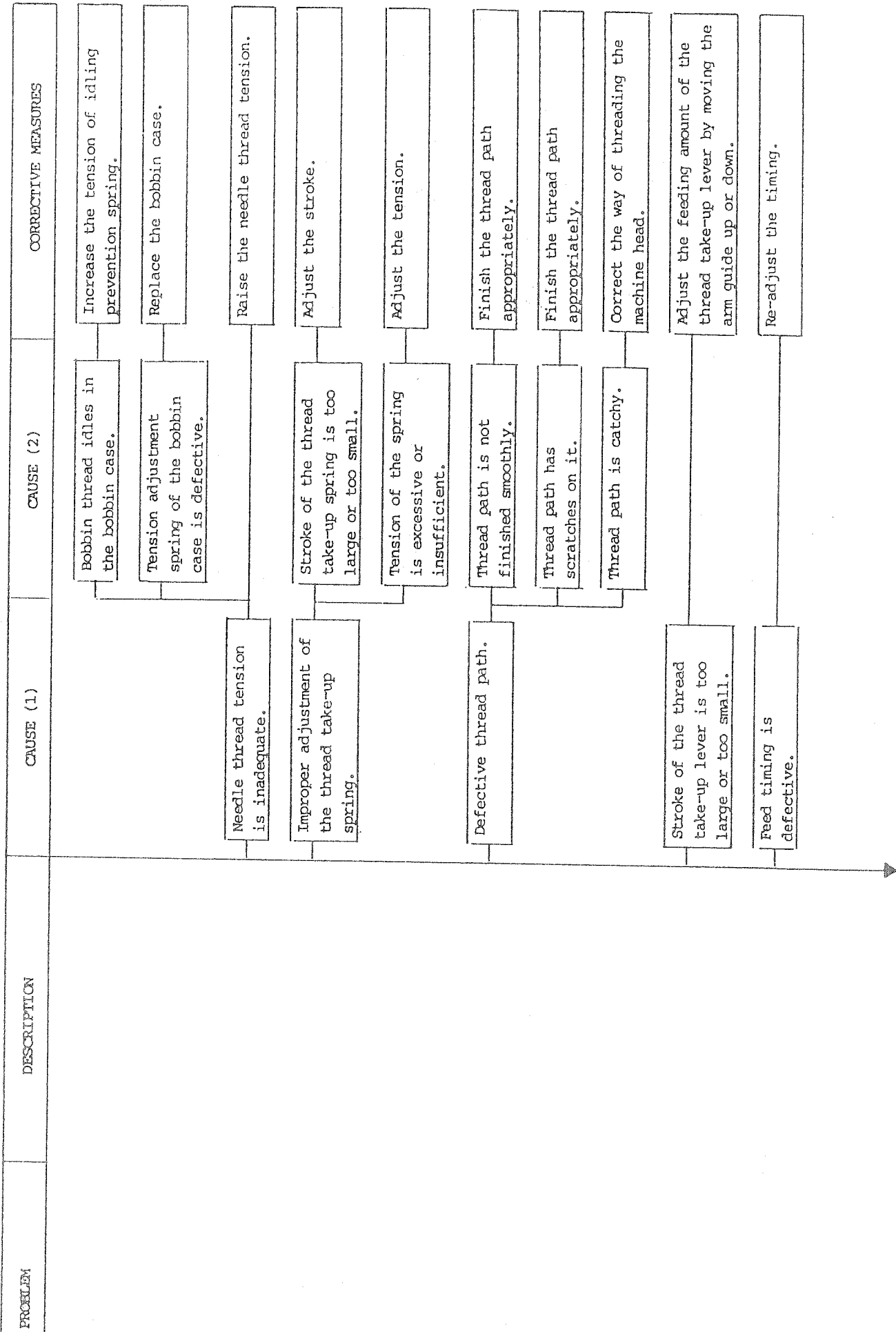

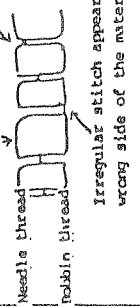
PROBLEM	DESCRIPTION	CAUSE (1)	CAUSE (2)	CORRECTIVE MEASURES
4. Irregular stitches	<p>Knotting point of stitches appears irregularly on the right or wrong side of the material.</p>  <p>Irregular stitch appear on the seam, right side of the material.</p> <p>Irregular stitch appear on the wrong side of the material.</p>	Hook components are defective.	Surface of the race is not sufficiently lubricated.	Lubricate the surface of the race.
			Dust is accumulated on the reverse face of the inner hook.	Clean up the inner hook.
			Hook timing is too early.	Retard the hook timing.
			Defective hook (thread is caught in it), defective thread path etc.	Replace the hook and correct the thread path.
			Clearance in the bobbin case opening lever is excessive.	Reduce the clearance.
			Clearance between the throat plate and the bobbin case opening lever is too small.	Adjust the clearance using a spacer for adjusting the height of the hook.
		Defective bobbin or bobbin case.	Bobbin thread is not fed smoothly due to defective engagement between the bobbin and the bobbin case.	Replace the bobbin or the bobbin case.
			Bobbin is not wound properly, so the bobbin thread is caught in the bobbin.	Adjust the bobbin winder tension. Adjust the position of the tension for the bobbin winder.



PROBLEM	DESCRIPTION	CAUSE (1)	CAUSE (2)	CORRECTIVE MEASURES
		Defective position of the top roller	Clearance between the needle and the top roller is too large.	Reduce the clearance.
		Improper height of the bottom roller	The bottom roller is positioned too high.	Lower the bottom roller.

10. TROUBLE IN FUNCTIONS OF ADDITIONAL DEVICES AND CORRECTIVE MEASURES

PHENOMENON	CAUSE (1)	CAUSE (2)	INSPECTION PROCEDURE AND ADJUSTMENT PROCEDURE
1. A few stitch skips at the sewing start.	1-1) Needle thread length remaining in the tip of the needle is too short.	1)-A Needle thread path has some trouble, excessive thread tension at thread trimming may result.	Inspect the needle thread path, and correct the tangled thread on the thread guide pin or adjust the position of the thread guide on thread stand base.
		1)-B Tension of the tension disc No.1 is excessive.	Decrease the tension by turning the thread tension adjusting nut counterclockwise.
		1)-C Tension disc No.2 is not released enough to float up properly at the time of thread trimming.	Adjust the installation position of the thread tension releasing solenoid, and confirm that the solenoid functions when it is energized.
		1)-D Thread trimming timing is too early.	Check and adjust the thread trimming timing according to the explanation given on page 21.
		1)-E Rotary knife and hook are damaged.	Check the hook and knife for damage. If any damage is found, buff it up. If the damage is too large to be corrected, replace the relevant part.
		1)-F Needle clamp supplied with the machine is not used when using Andaria thread or nylon bond thread.	Replace the needle clamp.
	1-2) Bobbin thread is not clamped.	2)-A Installation position of the clamp spring is not proper.	Confirm that the equal clearance is obtained on the left-/right-hand sides of the spring with regard to the groove in the rotary knife.
		2)-B Clamp spring pressure is inadequate.	Inspect and adjust the pressure according to the explanation given on page 27.
		2)-C Clamp spring is damaged.	Replace the clamp spring.

PHENOMENON	CAUSE (1)	CAUSE (2)	INSPECTION PROCEDURE AND ADJUSTMENT PROCEDURE
	1-3) The needle and throat plate used are not proper. Or the pressure of the presser foot is inadequate.	3)-A The needle is too thick.	The thinnest needle is recommended as long as loose stitches are not made.
		3)-B Needle hole in the throat plate is too large.	Replace the throat plate with the one with a smaller needle hole.
		3)-C Pressure of the presser foot is too weak.	Maximize the pressure using the pressure springs regulator.
	1-4) Blade point of the hook fails to catch the needle thread. (Thread breakage)	4)-A Defective timing between the needle and the hook.	Check the height of the needle bar and the timing of the hook.
		4)-B Tension and moving amount of the thread take-up spring are excessive.	Decrease the tension and decrease the moving amount.
		4)-C Blade point of the hook is worn out.	Correct the blade point the hook, or replace the hook.
		4)-D Needle is improperly attached.	Adjust the inclination angle of the needle. If the needle is bent, replace it.
		4)-E Needle guard does not work effectively.	Adjust so that the needle guard is positioned closer to the needle.
1-5) Needle thread and bobbin thread are not knotted with ease at the sewing start.		5)-A Sewing speed at the sewing start is too fast, thereby preventing the threads from knotting.	Insert one or two stitches sewn at low speed by means of soft-start function.
1-6) The sewing material excessively flops.		6)-A Top roller is too far from the needle.	Inspect and adjust the top roller according to the explanation given on page 11. The frequency of occurrence of flop of materials is decreased by installing the top roller behind the needle entry.
		6)-B Height of the bottom roller is excessive.	Lower the bottom roller.

PHENOMENON	CAUSE (1)	CAUSE (2)	INSPECTION PROCEDURE AND ADJUSTMENT PROCEDURE
2. Thread comes off the needle eyelet at the sewing start.	2-1) Needle thread comes off immediately after thread trimming.	1)-A Since the thread trimming timing is too early, the knife cuts the thread on the needle side.	When the needle thread comes off the needle immediately after thread trimming, it is judged that the cause of the trouble is that the rotary knife does not spread the thread properly and cuts the needle thread remaining in the needle. Remove the throat plate and check inside. Now a needle thread cut to approximately 10mm (0.394") long may be found. At this time, retard the timing of the thread trimming cam.
		1)-B Race surface of the hook is not lubricated sufficiently.	Lubricate the race surface.
		1)-C At the time of thread trimming, the tension disk floating device is kept opened and therefore does not clamp the thread.	Inspect and check the tension disk floating device according to the explanation given on page 29.
		1)-D Tension of the tension disc No.1 is excessive.	Decrease the tension by turning the thread tension adjusting nut of the tension disk No.1 counterclockwise.
	2-2) Needle thread and bobbin thread are not knotted with ease at the sewing start.	2)-A Sewing speed at the sewing start is too fast, thereby preventing the threads from knotting.	Insert one or two stitches sewn at low speed by means of soft-start function.
3. Needle thread is not cut at the time of thread trimming. (Bobbin thread is cut.)	3-1) Stitch skipping at the sewing end.	1)-A Needle is attached improperly.	Attach the needle properly. Check whether the needle is bent.
		1)-B Improper adjustment of hook timing.	Check for stitch skipping at low speed sewing state. Then re-adjust the hook timing.

PHENOMENON	CAUSE (1)	CAUSE (2)	INSPECTION PROCEDURE AND ADJUSTMENT PROCEDURE
3-2) A part of knife blade does not cut well.	2)-A Blade plane of the counter knife is inclined with regard to the top surface of the rotary knife.	Adjust the installing condition of the counter knife so that the both planes are flush with each other.	
3-3) Needle thread does not properly spread or the needle thread is not caught.	3)-A Defective timing of the thread trimming cam.	Inspect and adjust the thread trimming cam according to the explanation given on page 21.	
	3)-B Rotary knife is damaged.	Replace the rotary knife.	
	3)-C Initial position of the rotary knife is too far from the operator.	Inspect and adjust the position of the rotary knife according to the explanation given on page 19.	
	3)-D The stroke of the rotary knife is too short.	Adjust the position of the rotary knife according to the explanation given on page 19.	
4-1) Bobbin thread does not properly spread or the needle thread is not caught.	1)-A Rotary knife is damaged.	Replace the rotary knife.	
	1)-B Initial position of the rotary knife is too far from the operator or the stroke is too short.	Inspect and adjust the position and stroke of the rotary knife according to the explanation given on page 19.	
4-2) Bobbin thread is not in the correct position for thread trimming at the time of thread trimming.	2)-A The bobbin other than the specified one is used.	Replace the bobbin with the specified one.	
	2)-B Bobbin case is not correctly threaded. Or the bobbin thread comes off the bobbin case.	Thread the bobbin in the normal manner.	





PHENOMENON	CAUSE (1)	CAUSE (2)	INSPECTION PROCEDURE AND ADJUSTMENT PROCEDURE
5. The material is not fed in the normal direction.	5-1) Lower clutch components are defective.	1)-A Clearance between the feed converting lever and the clutch returning spring pressing shaft is small.	Check and adjust the clearance according to the explanation given on page 13.
		1)-B Axis of feed rock shaft base is eccentric to the axis of reverse feed shaft base.	Adjust so that the axes are concentric with each other.
		1)-C Backlash of the converting gear is excessively eliminated.	Re-adjust the backlash.
6. The material is not fed in the reverse direction.	6-1) Lower clutch components are defective.	1)-A Clearance between the feed converting lever and the clutch returning spring pressing shaft is large.	Check and adjust the clearance according to the explanation given on page 13.
		1)-B Axis of feed rock shaft base is eccentric to the axis of reverse feed shaft base.	Adjust so that the axes are concentric with each other.
		1)-C Backlash of the converting gear is excessively eliminated.	Re-adjust the backlash.
		1)-D Clearance in the clutch is too large or too small.	Check and adjust the clearance according to the explanation given on page 13.
	6-2) Reverse feed magnet is defective.	2)-A Clearance between the reverse feed magnet and the residual plate on the plunger is too large or too small.	Check and adjust the clearance according to the explanation given on page 27.

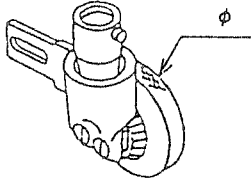
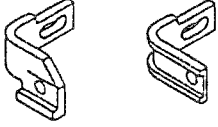
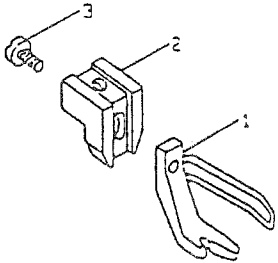

12. TABLE OF EXCHANGING GAUGE PARTS

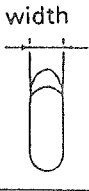
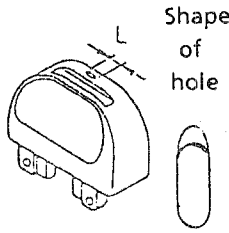
	Presser foot asm	Roller holder bracket	Needle guide asm (10585451)
Diameter of roller $\phi$		$\phi 25.4$ $\phi 31$ $\phi 35$ 	
mm			
$\phi 25.4$	10507556	10507804	1. 10585453 1
$\phi 31$	10569754	10507804	2. 10534303 1
$\phi 35$	#01 10506756	#01 10507408	3. SS7110510SP 1

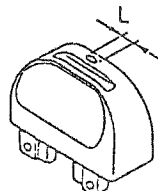
(NOTE)  
#01.....Standard type

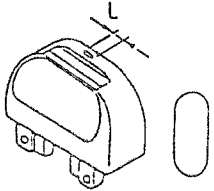
Throat plate		L=2.3mm	L=2.3mm	L=3.3mm	L=2.3mm
CODE	width  mm	 Shape of hole 			
A	1.2	—————	10524502	10595007	10596203
B	1.6	#01 10543809	10595700	10595106	10596302
C	2.1	10531903	10595809	10595205	10596401

(NOTE)  
#01.....Standard type

(NOTE) The needle size should be used is shown as below.  
 • A type throat plate Needle size #65~#80  
 • B type throat plate Needle size #75~#110  
 • C type throat plate Needle size #110~#125





**JUKI**

**JUKI CORPORATION**

BUSINESS OFFICE  
1-23-3, Kabuki-cho,  
Shinjuku-ku, Tokyo 160, Japan  
TELEX : J22967, 232-2301  
PHONE : 03 (3205) 1081  
FAX : 03 (3205) 9132

