

INSTRUCTION

DVK SERIES

Industrial Sewing Machines

DVK1702B
DVK1702P, PMD
DVK1702BK, PBK
DVK1701EHD
DVK1702EHD
DVK1702MLH

Second edition : March 2001

No. 010012

KANSAI
SPECIAL®

INTRODUCTION

Thank you for your purchasing Kansai Special's DVK Series.

Read and study this instruction manual carefully before beginning any of the procedures and save it for later use.

1. This instruction manual describes adjustments and maintenance procedures on this machine.
2. Before starting the machine, check to make sure the pulley cover, safety cover, etc. are secured.
3. Before adjusting, cleaning, threading the machine or replacing the needle, be sure to turn off the power.
4. Never start the machine with no oil in the reservoir.
5. Refer to the parts list as well as this instruction manual before performing preventive maintenance.
6. The contents described in this instruction manual are subject to change without notice.

CONTENTS

1. NEEDLES & THREADING THE MACHINE	
1-1 Needles	1
1-2 Replacing the needle	1
1-3 Threading the machine	1
2. MACHINE SPEED	
2-1 Machine speed & direction in which the machine pulley runs	2
2-2 Motor & belt	2
3. LUBRICATION	
3-1 Oil	3
3-2 Oiling	3
3-3 Replacing the oil and the filter element	3
4. SEWING MACHINE INSTALLATION	
4-1 Cutting the machine table	4
4-2 Installing the machine	5
5. TIMING OF THE LOOPER TO THE NEEDLES	
5-1 Angle and height for installing the looper ...	5
5-2 Looper left-to-right movement	6
5-3 Looper setting distance	6
5-4 Needle height	6
5-5 Needle/looper front-to-back relationship ...	7
6. ADJUSTING THE NEEDLE GUARDS	
6-1 Position of the needle guard (rear)	7
6-2 Position of the needle guard (front)	8
7. ADJUSTING THE FEED DOG & STITCH LENGTH	
7-1 Feed dog height & tilt	8
7-2 Stitch length	8
8. ADJUSTING THE PRESSER FOOT	
8-1 Presser foot pressure	9
8-2 Position of the presser foot & foot lift	9
9. ADJUSTING THE STITCH FORMATION	
9-1 Position of the thread support	10
9-2 Position of the looper thread eyelets	10
9-3 Position of the looper thread take-up	10
10. ADJUSTING THE REAR PULLER DEVICE	
10-1 Manual lever	11
10-2 To adjust the puller pressure	11
10-3 Adjusting the feeding amount of the rear puller	11
11. ADJUSTING THE FRONT PULLER DEVICE	
11-1 To insert elastic and adjust the feeding amount of the front puller	11
12. ADJUSTING THE BK AUXILIARY FEEDING DEVICE	
12-1 Auxiliary feed dog height & tilt	12
12-2 Installing the auxiliary presser foot	12
13. ADJUSTING THE BK FRONT KNIFE DEVICE	
13-1 Adjusting the clearance between the left and right knives	13
13-2 Disassembling/reassembling the lower knives	13
13-3 Disassembling/reassembling the upper knives	14
13-4 Overlap of the upper and lower knives ...	14
13-5 Resharpener the lower knives	14
14. CLEANING THE MACHINE	14

【1】 NEEDLES & THREADING THE MACHINE

1-1 Needles

UY128GAS of Schmetz or Organ
 Select the proper needle for the fabric and thread.

< Needles and needle size > Except 1701 , 1702EHD

Schmetz	Nm75	Nm80	Nm90	Nm100	Nm110
Organ	#11	#12	#14	#16	#18

1701EHD.....DR2 Nm200 , #25

1702EHD.....UY143GS Nm200 , #25

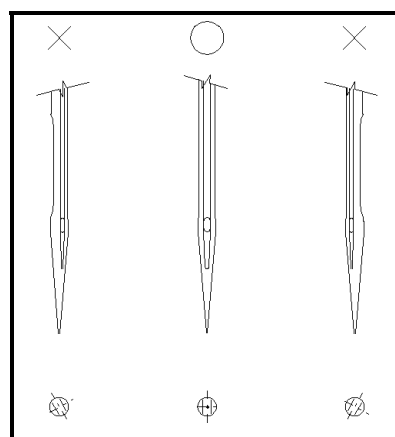

1-2 Replacing the needle

When replace the needle, check the needle carefully to see that the scarf is turned to the rear of the machine (see the illustration). Then install the needle correctly.

< Note >

*Before replacing the needle, be sure to turn off the machine.
 A clutch motor continues running for a while after the machine is turned off.
 Therefore keep on pressing the pedal until the machine stops.*

1-3 Threading the machine

Thread the machine correctly by referring to the illustration below.
 Threading the machine incorrectly may cause skip stitching, thread breakage and/or uneven stitch formation.

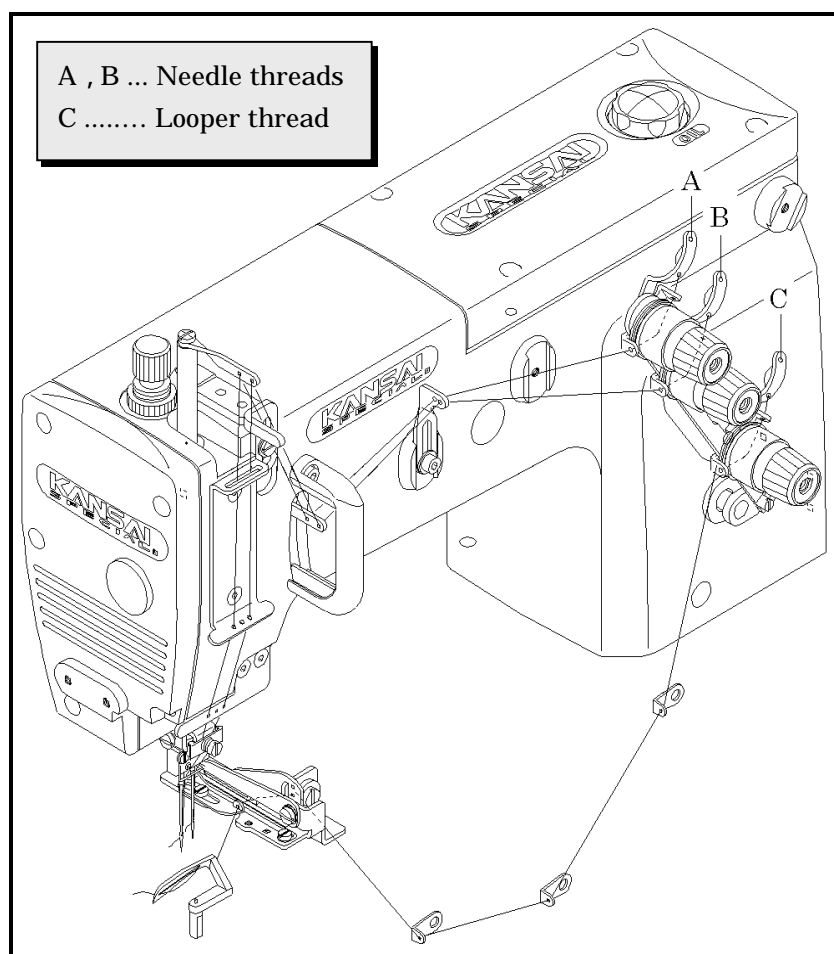

【2】 MACHINE SPEED

2-1 Machine speed & direction in which the machine pulley runs

Refer to the table below for maximum and standard speeds of the Series. To extend machine life, run the machine approximately 15-20% below the maximum speed for the first 200 hours of operation (approx. 1 month). Then run the machine at the standard speed. The machine pulley turns counterclockwise as seen from the end of the machine pulley.

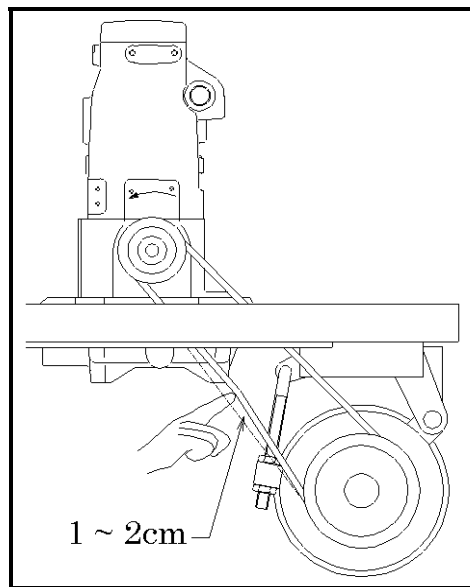

2-2 Motor & belt

Motor : 3-phase , 2-pole , 400W clutch motor

Belt : M type V belt

Select the proper motor pulley according to the machine speed (refer to the motor pulley outer diameter on the table below). Adjust where to position the motor by pressing the finger onto the middle of the belt so that 1~2cm deflection can be obtained (see the illustration on the right).

< Machine speed >

Type	Maximum speed	Standard speed
P , PMD , B	4500SPM	4000SPM
BK , EHD , MLH	4000SPM	3500SPM

< Motor pulley selection table >

Motor pulley outer diameter (mm)	Machine speed (SPM)	
	50Hz	60Hz
70	2900	3450
80	3300	3900
90	3700	4400
100	4100	(4900)
110	4500	

【3】 LUBRICATION

3-1 Oil

Use Kansai Special's genuine oil.
(Part No. 28-611)

3-2 Oiling

To fill the machine with oil
Remove oil plug A from the oil hole.
Fill the machine with oil until the oil level is at the top line (see H in the illustration) on oil gauge C.
After the first lubrication, add oil so that the oil level will be between H and L.

To check for proper oil flow
After filling the machine with oil, run the machine to check the oil is splashing from oil pipe outlet B.

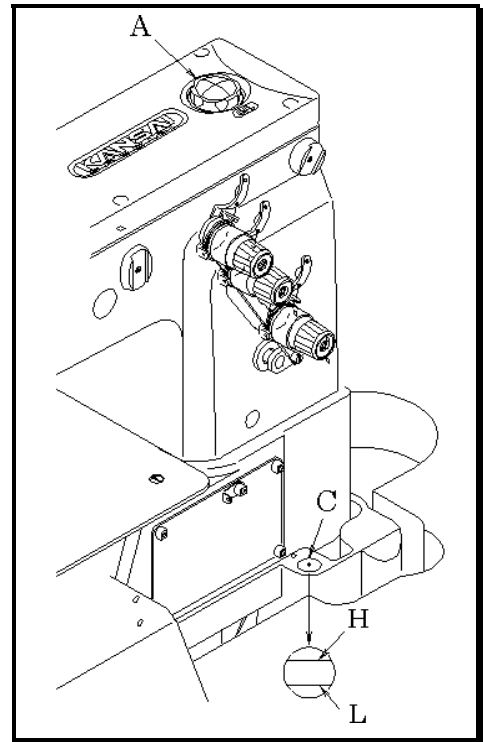

3-3 Replacing the oil and the filter element

To extend machine life, be sure to replace the oil after the first 250 hours of operation.

To replace the oil, follow the procedures below.

1. Remove the V belt from the motor pulley and then remove the machine from the table.
2. Remove screw D and then drain the oil.
Be careful not to stain V belt with the oil.
3. After draining the oil, be sure to tighten screw D.
4. Fill the machine with oil by referring to 3-2 shown above.

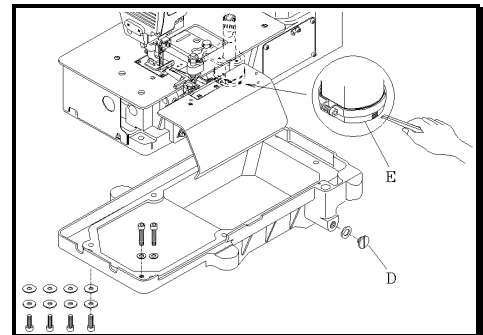

If filter element E is contaminated, proper oiling may not be performed.
Clean the filter element every six months. If just a little or no oil flows out from the nozzle with the proper amount of oil in the machine, check the filter element.
To clean the filter element, remove oil reservoir.

【4】 SEWING MACHINE INSTALLATION

4-1 Cutting the machine table

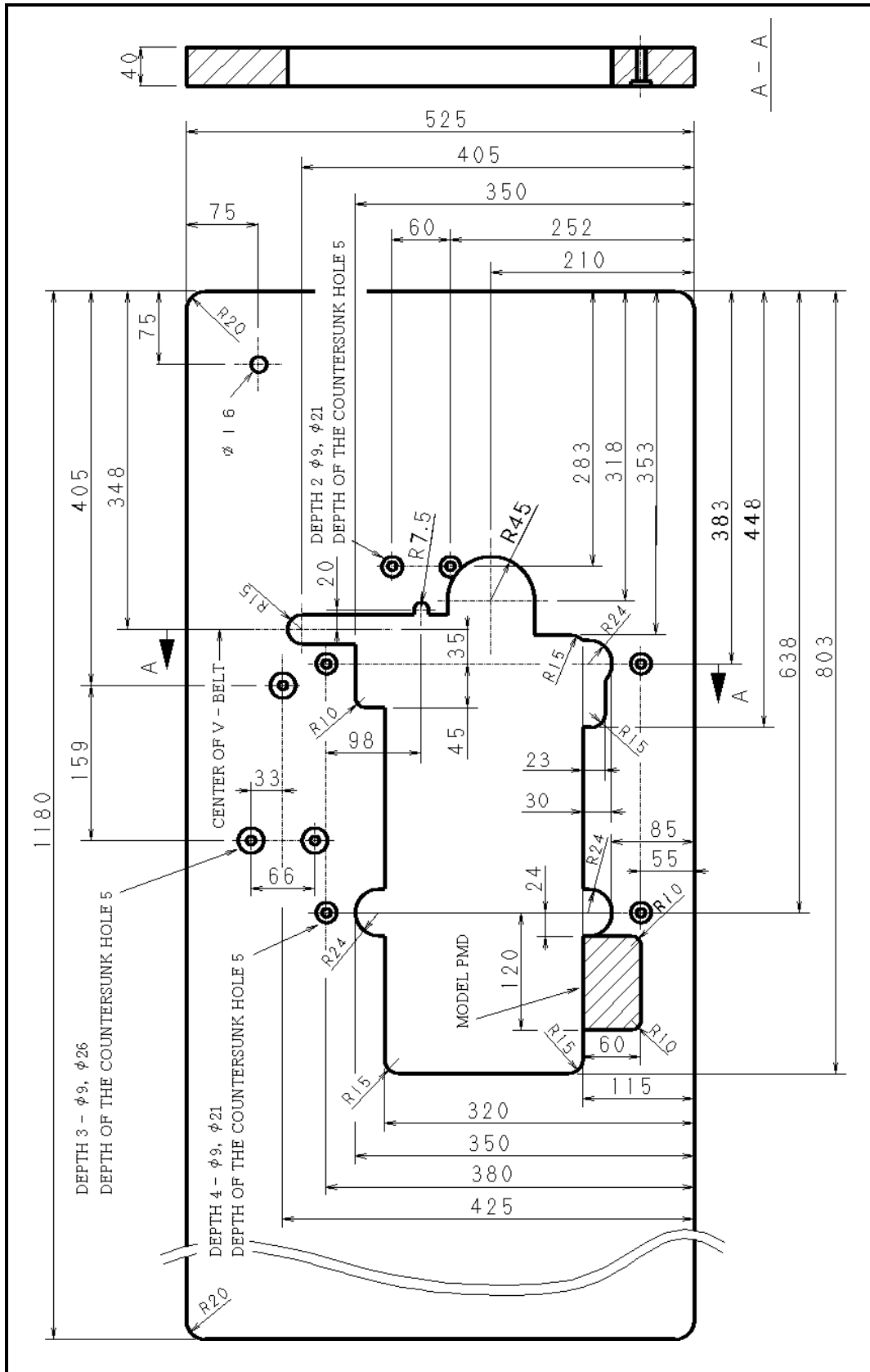

4-2 Installing the machine

Install the brackets on the underside of the table board (see the illustration below).
Fit the rubber cushions onto the brackets.
Mount the machine head on the rubber cushions.

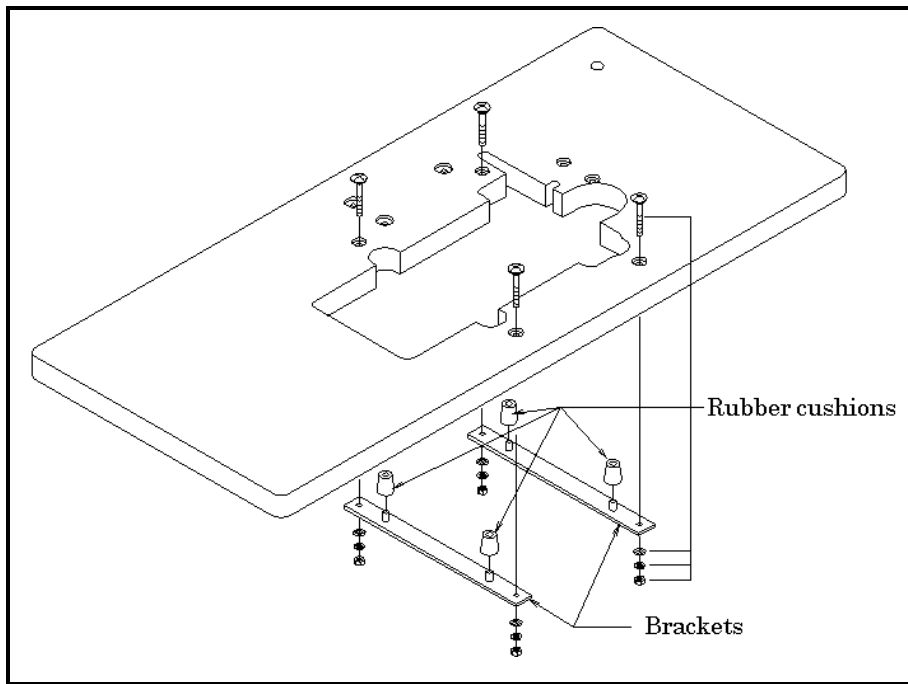

【5】TIMING OF THE LOOPER TO THE NEEDLES

5-1 Angle and height for installing the looper

To obtain the proper angle and height, insert the looper fully into looper holder A and then tighten screw B. The proper angle for the looper on P , PMD , B , BK is 3°. Distance at 25mm from the point of the looper between the bottom of the looper blade and the extension line from the point of the looper : Approximately 1.3mm.

The proper angle for the looper on MLH is 3.5°.

Distance at 20mm from the point of the looper between the bottom of the looper blade and the extension line from the point of the looper:

Approximately 1.2mm. The proper angle for the looper on EHD is 0°.

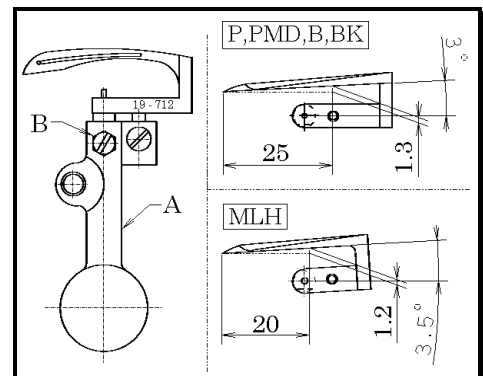

5-2 Looper left-to-right movement

When the point of the looper moves from the right/left to the left/right, distance A from the top of the left needle's eye to the point of the looper at the left side of the left needle should be equal (see the illustration on the right). To make this adjustment, remove the machine cover, loosen three screws C on looper eccentric B and then shift looper eccentric B by turning the machine pulley while holding looper eccentric B.

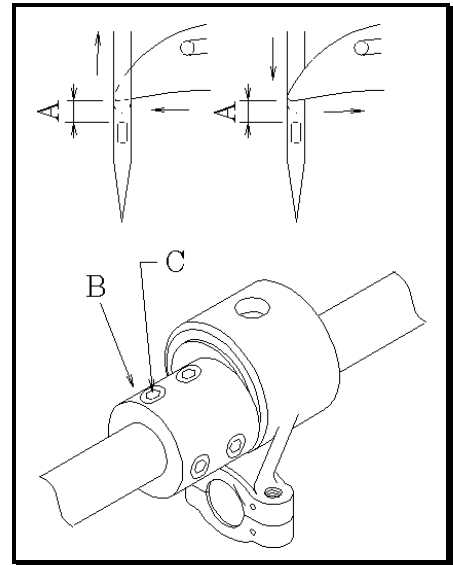

5-3 Looper setting distance

When the looper is at the extreme right end of its travel, adjust distance A from the point of the looper to the right side of the right needle. This distance varies by model and/or gauge size (see the table below). Adjustment is made by loosening screw B.

Model (gauge size)	Setting distance A (mm)
P , PMD , MLH (1/8 , 5/32)	5.2
P , PMD , (3/16 , 7/32 , 1/4)	4.4
B , BK , PBK	4.0
EHD	5.0

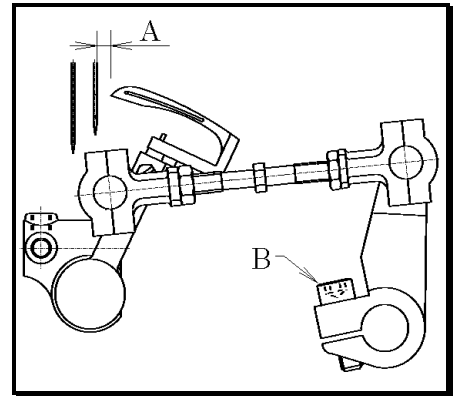

5-4 Needle height

When the point of the looper has reached the left side of the left needle with the machine pulley turned in the operating direction, adjust distance A from the top of the left needle's eye to the point of the looper on the back side of the needle.

This distance varies by model and/or gauge size (see the table below).

< Note >

After the above adjustment is made, install the needle plate and then check to make sure each needle drops correctly into the center of the each needle drop hole.

Model	A (mm)
P , PMD , MLH	1.2~1.5
B , BK , PBK	0~0.5
EHD	2~2.5

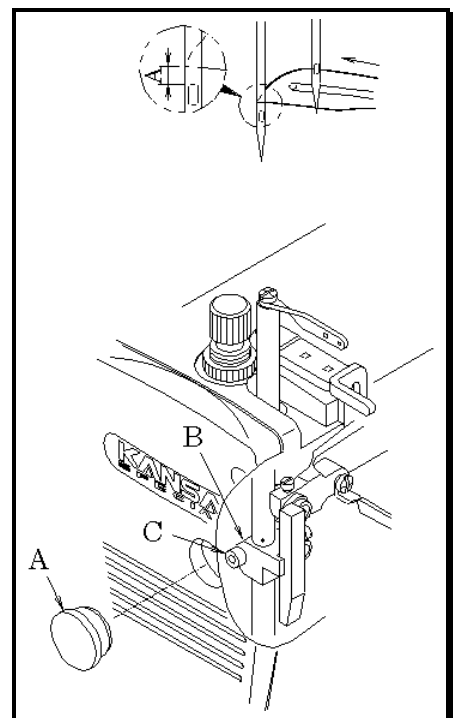

DVK series

5-5 Needle/looper front-to-back relationship

When the looper passes on the back side of the needle, the clearance between the right needle and the looper should be 0~0.05mm. Adjustment is made by loosening screw A. The clearance between the left needle and the looper should be 0.2mm.

Adjustment is made by loosening screw B on the looper avoid eccentric.

To increase the clearance, turn the looper avoid eccentric toward the back side of the machine.

To decrease the clearance, turn the looper avoid eccentric toward the front side of the machine.

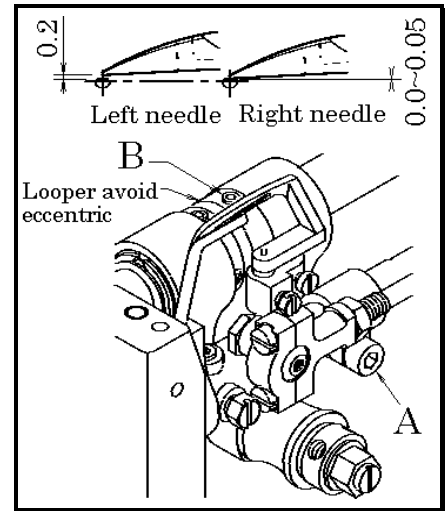

【6】 ADJUSTING THE NEEDLE GUARDS

6-1 Position of the needle guard (rear)

Movable type (for models except BK , PBK)

When the point of the looper has reached the center of the right needle, the distance from the point of the right needle to line (a) on needle guard A should be 1mm (approximately 2mm on EHD).

Then the clearance between the needle and the needle guard should be 0mm.

Adjustment is made by loosening screw B and turning screw C to move the needle guard up or down and/or front or back as required.

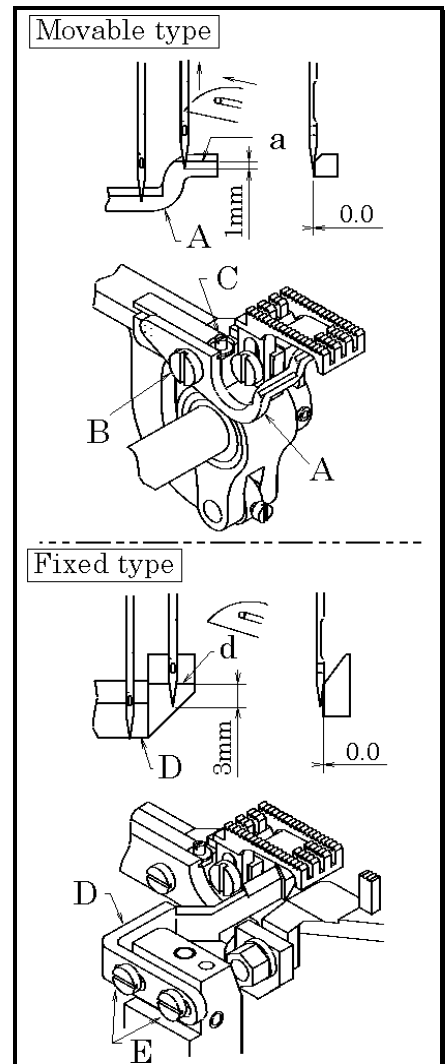

Fixed type (for BK , PBK)

When the needle bar is at the bottom of its stroke, the distance from the point of the right needle to line (d) on needle guard D should be approximately 3mm.

Then the clearance between the needle and the needle guard should be 0mm.

Adjustment is made by loosening screws E.

6-2 Position of the needle guard (front)

When the point of the looper has reached the center of the right needle, the center of the right needle's eye should be aligned with line A on the needle guard (front).

In addition, the left and right needles should be parallel with the needle guard (front).

Adjustment is made by loosening screw B.

The clearance between the needles and the needle guard (front) should be 0.2~0.5mm.

Adjustment is made by loosening screw C.

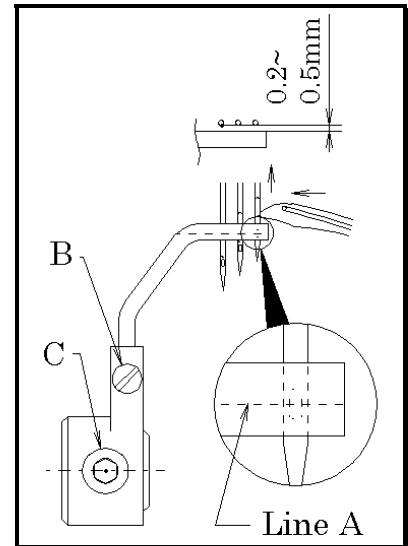

【7】 ADJUSTING THE FEED DOG & STITCH LENGTH

7-1 Feed dog height & tilt

Height adjustment

When the feed dog is at the top of its stroke, the feed dog teeth should be 1.0~1.2mm (1.5mm on EHD) above the top surface of the needle plate.

Adjustment is made by loosening screw A.

Tilt adjustment

When the feed dog is at the top of its stroke, the feed dog teeth should be parallel with the top surface of the needle plate. Adjustment is made by loosening screw B and turning screw C.

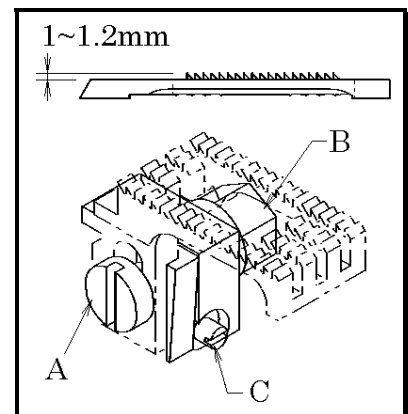

7-2 Stitch length

Loosen bolt A (left-hand thread) with a 9.5mm T-wrench. Then turn screw B. To increase the stitch length, turn screw B counterclockwise.

To decrease the stitch length, turn screw B clockwise.

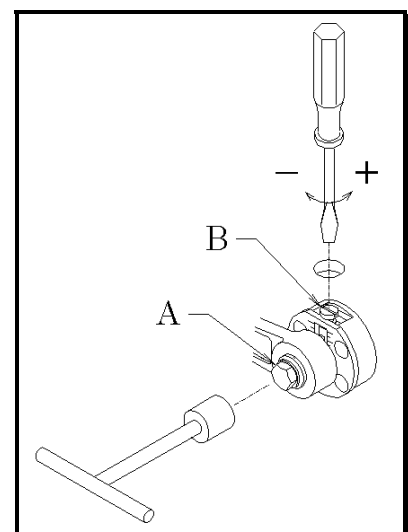

【8】 ADJUSTING THE PRESSER FOOT

8-1 Presser foot pressure

The presser foot pressure should be as light as possible, yet be sufficient to feed the fabric and produce uniform stitches.

To increase the presser foot pressure, turn the adjusting knob clockwise.

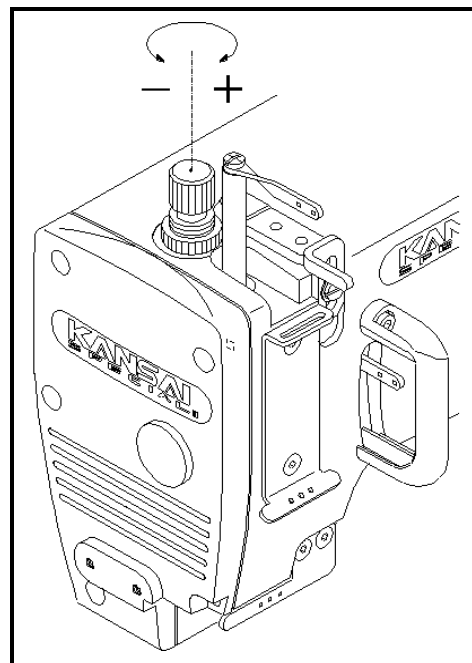

8-2 Position of the presser foot & foot lift

Fit the presser foot onto the presser bar so that the needle can drop correctly to the center of the presser foot needle drop hole.

Position of the presser foot

Loosen screw A. Adjust by moving the presser foot left or right while checking to make sure the needle drops correctly to the center of the presser foot needle drop hole.

Foot lift

The presser foot should be 8~10mm above the top surface of the needle plate.

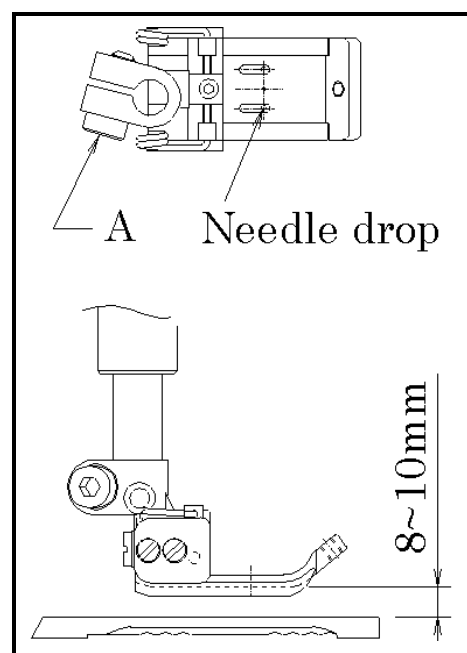

Set stopper B at the required position.

Fasten the presser foot lift lever with nut C so that the lever cannot be lowered.

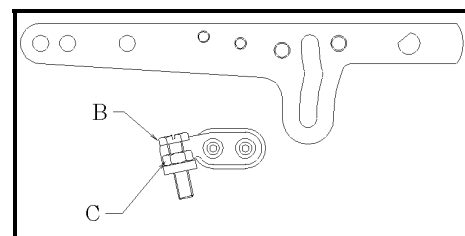

【9】 ADJUSTING THE STITCH FORMATION

9-1 Position of the thread support

When the needle bar is at the bottom of its stroke, the centers of the eyes on thread eyelet A should be level with the top surface of thread support B, and A should be parallel with B.

Height adjustment of thread support B is made by loosening screw C and moving thread support B up or down. Moving thread support B up tightens the needle thread. Moving thread support B down loosens the needle thread.

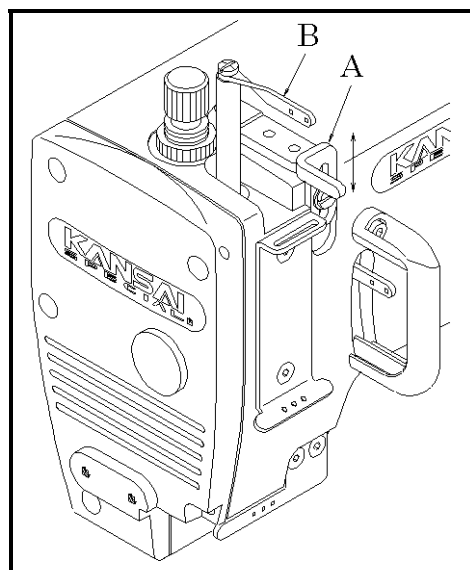

9-2 Position of the looper thread eyelets

Align the eyes on looper thread eyelets A with the center of the shaft. Adjust the position of the eyes on looper thread eyelets A by loosening screws B according to the sewing conditions such as the fabric and/or thread to be used.

To increase the amount of the looper thread to be supplied, move looper thread eyelets A toward the rear side of the machine.

To decrease the amount of the looper thread to be supplied, move looper thread eyelets A toward the front side of the machine.

Thread guide C should be 6~7mm above the top surface of the guide plate.

Adjustment is made by loosening screw D.

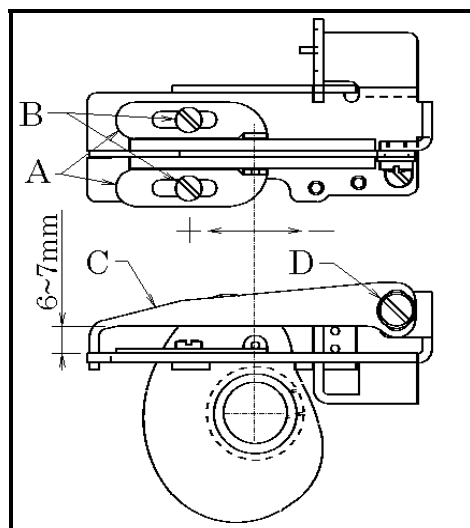

9-3 Position of the looper thread take-up

When the point of the needle has reached bottom surface A of the looper blade while the looper is moving to the right from the extreme left end of its travel, the looper thread should be removed from point C on looper thread take-up B.

Adjustment is made by loosening and then tightening screw D.

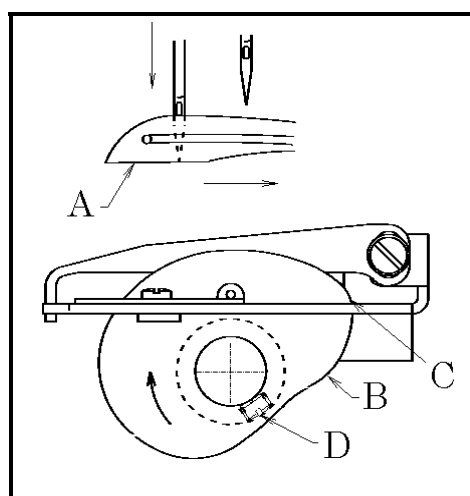

【10】 ADJUSTING THE REAR PULLER DEVICE

10-1 Manual lever

To position or remove the fabric, raise manual lever A.

10-2 To adjust the puller pressure

The puller pressure should be as light as possible, yet be sufficient to feed the fabric smoothly.

To increase the pressure, turn adjusting knob D clockwise. To decrease the pressure, turn adjusting knob D counterclockwise.

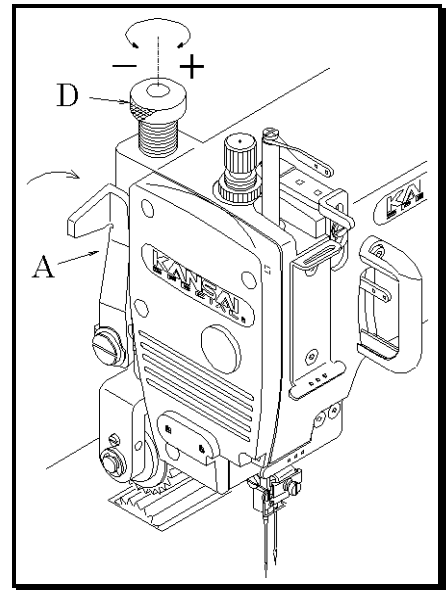

10-3 Adjusting the feeding amount of the rear puller

Adjust the feeding amount of the rear puller according to that of the feed dog.

To increase the amount, loosen nut G and move it to the left. To decrease the amount, move it to the right.

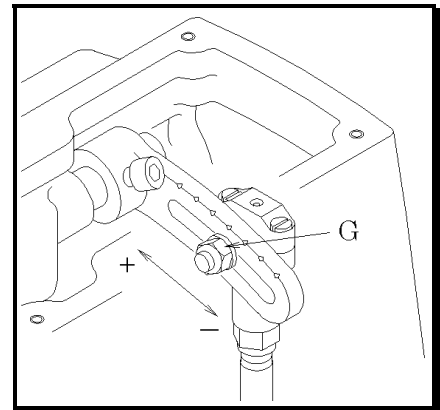

【11】 ADJUSTING THE FRONT PULLER DEVICE

11-1 To insert elastic and adjust the feeding amount of the front puller

Insert elastic by opening/closing small roller C with lever A (see the illustration).

Adjust the feeding amount of the front puller according to that of the feed dog.

To decrease the amount, loosen screw B and move it up. To increase the amount, move it down.

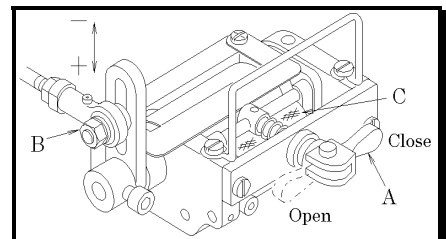

【12】 ADJUSTING THE BK AUXILIARY FEEDING DEVICE

12-1 Auxiliary feed dog height & tilt

Height adjustment

When auxiliary feed dog A is at the top of its stroke, the auxiliary feed dog teeth should be 1.5mm above the top surface of auxiliary feed dog plate B.

Adjustment is made by loosening screw C.

Tilt adjustment

When auxiliary feed dog A is at the top of its stroke, auxiliary feed dog A should be parallel with auxiliary feed dog plate B.

Adjustment is made by loosening screw D and turning screw E.

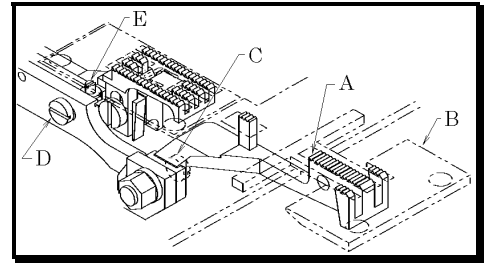

12-2 Installing the auxiliary presser foot

Install the auxiliary presser foot on the presser bar with spring A pressed down to approximately 10mm.

Then tighten screw B.

Position collar C so that there is a clearance of 2mm between collar C and guide plate D.

Then tighten screw E.

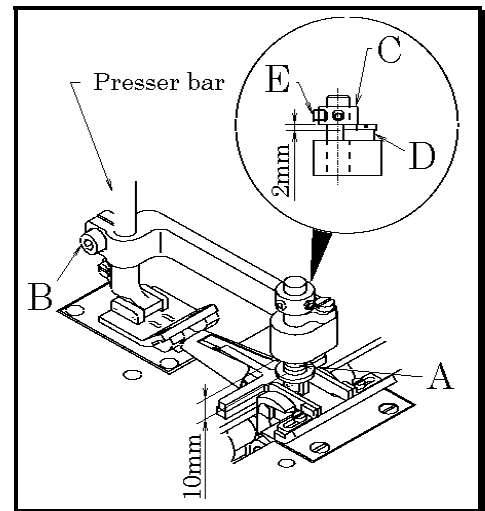

【13】 ADJUSTING THE BK FRONT KNIFE DEVICE

13-1 Adjusting the clearance between the left and right knives

Clearance A should be divided into half by the center line of the needle bar.

To make the above adjustment

1. Loosen the upper (left and right) knives by loosening screws B and C.
2. To adjust the clearance between the lower left and right knives, loosen screws D and E.
3. Fit lower knife (left and right) holders F and G onto guide plates H. Tighten screws D and E.
4. Fit upper knife (right) P onto the lower knife (right). Then tighten screw C.
5. Fit upper knife (left) O onto the lower knife (left). Move upper joint bracket I to the right to press spring J. Then tighten screws B while pressing them to the flat spot.

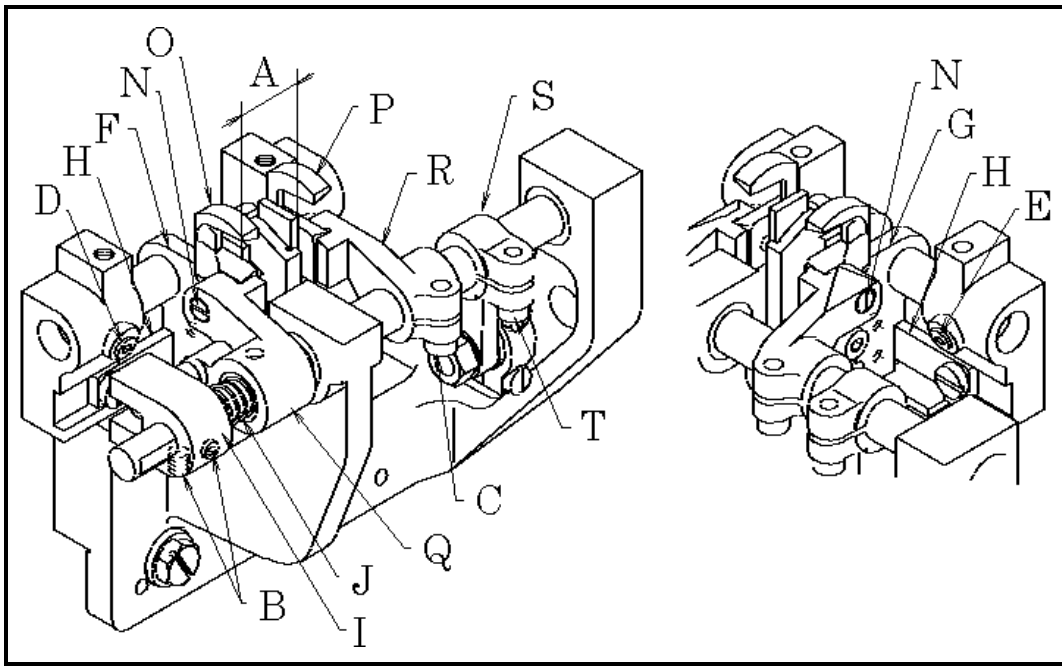

13-2 Disassembling/reassembling the lower knives

To disassemble the lower knives

1. Loosen screws B.
Move upper knife joint bracket I to the left so that the spring can be released.
2. Remove the lower knives by removing screws K.

To reassemble the lower knives

1. Install lower knives L on knife holder F or G with the point of each cutting edge turned outside.
2. Adjust lower knives L so that each cutting edge of lower knives L is flush with the top surface of auxiliary feed dog plate. Then tighten screws K.
3. Move upper joint bracket I to the right to press spring J. Then tighten screws B while pressing them to the flat spot.

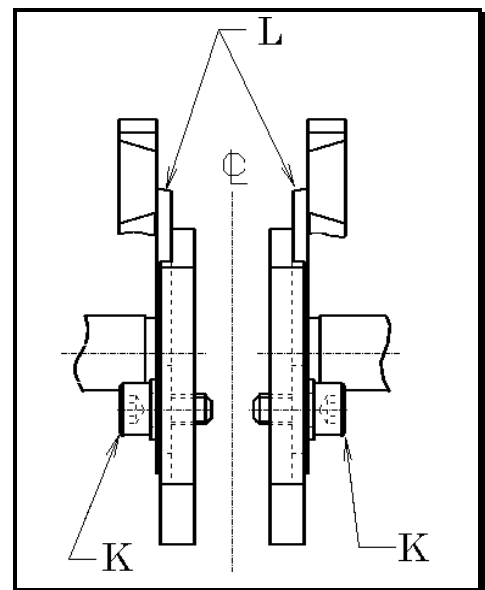

13-3 Disassembling/reassembling the upper knives

To disassemble the upper knives

1. Loosen screws B.
Move upper knife joint bracket I to the left so that the spring can be released.
2. Loosen screws N. Remove upper knives O and P by moving them up.

To reassemble the upper knives

1. Insert the upper knives to the proper depth along the guides on upper knife brackets Q and R. Then tighten screws N.
2. Move upper joint bracket I to the right to press spring J. Then tighten screws B while pressing them to the flat spot.

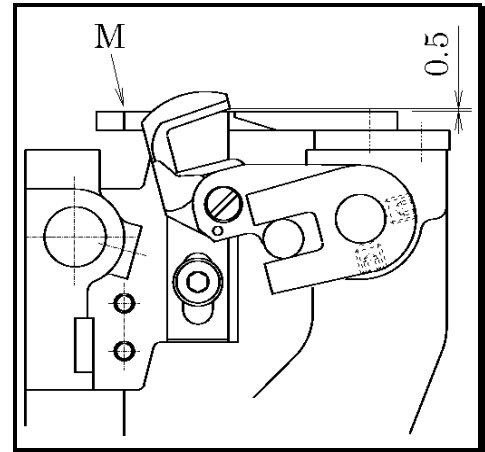

13-4 Overlap of the upper and lower knives

When upper knives O and P are at the bottom of their stroke, there should be a clearance of 0.5mm between the points of the cutting edges of the upper knives and those of the lower knives.

Adjustment is made by loosening screw T on upper knife drive lever S.

13-5 Resharpener the lower knives

Resharpener the lower knives when they become dull. It is recommended spare upper and lower knives are always kept for replacement.

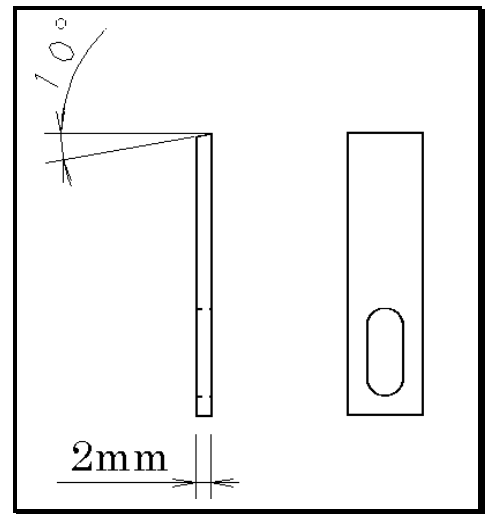

【14】CLEANING THE MACHINE

At the end of each day, remove the presser foot and the needle plate and then clean the slots of the needle plate and the area around the feed dogs.

