

PFAFF

1163

Instruction Manual

This instruction manual applies to machines from the following serial numbers onwards:

6001000 →



This Instruction Manual is valid for all models and subclasses listed in the chapter " **Specifications** ".



The adjustment manual for the machines can be downloaded free of charge from the internet address

www.pfaff-industrial.com/de/service/download/index.php3.

As an alternative to the internet download the adjustment manual can also be ordered in book form under part no. 296-12-18 609/002.

The reprinting, copying or translation of PFAFF Instruction Manuals, whether in whole or in part, is only permitted with our previous authorization and with written reference to the source.

PFAFF Industrie Maschinen AG

Postfach 3020

D-67653 Kaiserslautern

Königstr. 154

D-67655 Kaiserslautern

	Contents	Chapter - Page
1	Safety	1 - 1
1.01	Directives	1 - 1
1.02	General notes on safety	1 - 1
1.03	Safety symbols	1 - 2
1.04	Important points for the user	1 - 2
1.05	Important points for the user	1 - 3
1.05.01	Operating personnel	1 - 3
1.05.02	Operating personnel	1 - 3
1.06	Danger	1 - 4
2	Proper use	2 - 1
3	Specifications	3 - 1
3.01	PFAFF 1163	3 - 1
3.02	Models and subclasses	3 - 1
4	Disposal of machine	4 - 1
5	Transport, packaging and storage	5 - 1
5.01	Transport to the customer's premises	5 - 1
5.02	Transport within the customer's premises	5 - 1
5.03	Disposal of the packaging	5 - 1
5.04	Storage	5 - 1
6	Explanation of the symbols	6 - 1
7	Controls	7 - 1
7.01	On/Off switch	7 - 1
7.02	Pedal	7 - 1
7.03	Lever for raising the presser foot	7 - 2
7.04	Knee lever	7 - 2
7.05	Stitch length adjustment wheel	7 - 3
7.06	Reverse stitch key	7 - 3
7.07	Key on machine head	7 - 4
7.08	Switch for thread wiper –909/93	7 - 4
7.09	Control panel	7 - 5
7.09.01	Screen displays	7 - 5
7.09.02	Function keys	7 - 5

	Contents	Chapter - Page
8	Mounting and commissioning the machine	8 - 1
8.01	Mounting	8 - 1
8.01.01	Adjusting the table-top height	8 - 1
8.01.02	Fitting the oil pan	8 - 2
8.01.03	Mounting the sewing head	8 - 3
8.01.04	Mounting the balance wheel	8 - 3
8.01.05	Tightening the V-belt	8 - 4
8.01.06	Mounting the top V-belt guard	8 - 4
8.01.07	Mounting the bottom V-belt guard	8 - 5
8.01.08	Fitting the thread guide	8 - 5
8.01.09	Mounting the spool holder	8 - 6
8.02	Connecting the plug-in connections and earth cables	8 - 7
8.03	Commissioning	8 - 8
8.04	Switching the machine on/off	8 - 8
8.05	Basic setting of the machine drive unit	8 - 8
8.06	Table top cutout	8 - 10
9	Preparation	9 - 1
9.01	Inserting the needle	9 - 1
9.02	Winding the bobbin thread / adjusting the preliminary thread tension	9 - 2
9.03	Removing/Inserting the bobbin case	9 - 3
9.04	Inserting the bobbin case / Adjusting the bobbin thread tension	9 - 3
9.05	Threading the needle thread / adjusting the needle thread tension	9 - 4
9.06	Entering the start and end backtacks	9 - 5
10	Sewing	10 - 1
10.01	Darning program	10 - 2
10.02	Counted seam	10 - 2
10.03	Error messages	10 - 3
11	Care and maintenance	11 - 1
11.01	Cleaning the machine	11 - 1
11.02	Checking the oil level / filling in oil	11 - 2
11.03	Adjusting the lubrication	11 - 3
11.03.01	Lubricating the needle head parts	11 - 3
11.03.02	Hook lubrication	11 - 3
12	Wearing parts	12 - 1

1 Safety

1.01 Directives

This machine is constructed in accordance with the European regulations contained in the conformity and manufacturer's declarations.

In addition to this Instruction Manual, also observe all generally accepted, statutory and other regulations and legal requirements and all valid environmental protection regulations!

The regionally valid regulations of the social insurance society for occupational accidents or other supervisory organizations are to be strictly adhered to!

1.02 General notes on safety

- This machine may only be operated by adequately trained operators and only after having completely read and understood the Instruction Manual!
- All Notes on Safety and Instruction Manuals of the motor manufacturer are to be read before operating the machine!
- The danger and safety instructions on the machine itself are to be followed!
- This machine may only be used for the purpose for which it is intended and may not be operated without its safety devices. All safety regulations relevant to its operation are to be adhered to.
- When exchanging sewing tools (e.g. needle, roller presser, needle plate and bobbin), when threading the machine, when leaving the machine unattended and during maintenance work, the machine is to be separated from the power supply by switching off the On/Off switch or by removing the plug from the mains!
- Everyday maintenance work is only to be carried out by appropriately trained personnel!
- Repairs and special maintenance work may only be carried out by qualified service staff or appropriately trained personnel!
- Work on electrical equipment may only be carried out by appropriately trained personnel!
- Work is not permitted on parts and equipment which are connected to the power supply! The only exceptions to this rule are found in the regulations EN 50110.
- Modifications and alterations to the machine may only be carried out under observance of all the relevant safety regulations!
- Only spare parts which have been approved by us are to be used for repairs! We expressly point out that any replacement parts or accessories which are not supplied by us have not been tested and approved by us. The installation and/or use of any such products can lead to negative changes in the structural characteristics of the machine. We are not liable for any damage which may be caused by non-original parts.

1.03

Safety symbols



Danger!
Points to be observed.



Danger of injury for operating and specialist personnel!



Caution

Do not operate without finger guard and safety devices.
Before threading, changing bobbin and needle, cleaning
etc. **switch off main switch.**

1.04

Important points for the user

- This Instruction Manual is an integral part of the machine and must be available to the operating personnel at all times.
- The Instruction Manual must be read before operating the machine for the first time.
- The operating and specialist personnel is to be instructed as to the safety equipment of the machine and regarding safe work methods.
- It is the duty of the user to only operate the machine in perfect running order.
- It is the obligation of the user to ensure that none of the safety mechanisms are removed or deactivated.
- It is the obligation of the user to ensure that only authorized persons operate and work on the machine.

Further information can be obtained from your PFAFF agent.

1.05 Operating and specialist personnel

1.05.01 Operating personnel

Operating personnel are persons responsible for the equipping, operating and cleaning of the machine as well as for taking care of problems arising in the sewing area.

The operating personnel is required to observe the following points and must:

- always observe the Notes on Safety in the Instruction Manual!
- never use any working methods which could adversely affect the safety of the machine!
- not wear loose-fitting clothing or jewelery such as chains or rings!
- also ensure that only authorized persons have access to the potentially dangerous area around the machine!
- always immediately report to the person responsible any changes in the machine which may limit its safety!

1.05.02 Specialist personnel

Specialist personnel are persons with a specialist education in the fields of electrics, electronics and mechanics. They are responsible for the lubrication, maintenance, repair and adjustment of the machine.

The specialist personnel is obliged to observe the following points and must:

- always observe the Notes on Safety in the Instruction Manual!
- switch off the On/Off switch before carrying out adjustments or repairs, and ensure that it cannot be switched on again unintentionally!
- wait until the luminous diode on the control box is no longer blinking or on before beginning adjustment or repair work.
- never work on parts which are still connected to the power supply! Exceptions are explained in the regulations EN 50110.
- replace the protective coverings and close the electrical control box after all repairs or maintenance work!

1.06

Danger



A working area of 1 meter is to be kept free both in front of and behind the machine while it is in operation so that it is always easily accessible.



Never reach into the sewing area while sewing! Danger of injury by the needle!



Never leave objects on the table while adjusting the machine settings! Objects can become trapped or be slung away! Danger of injury!

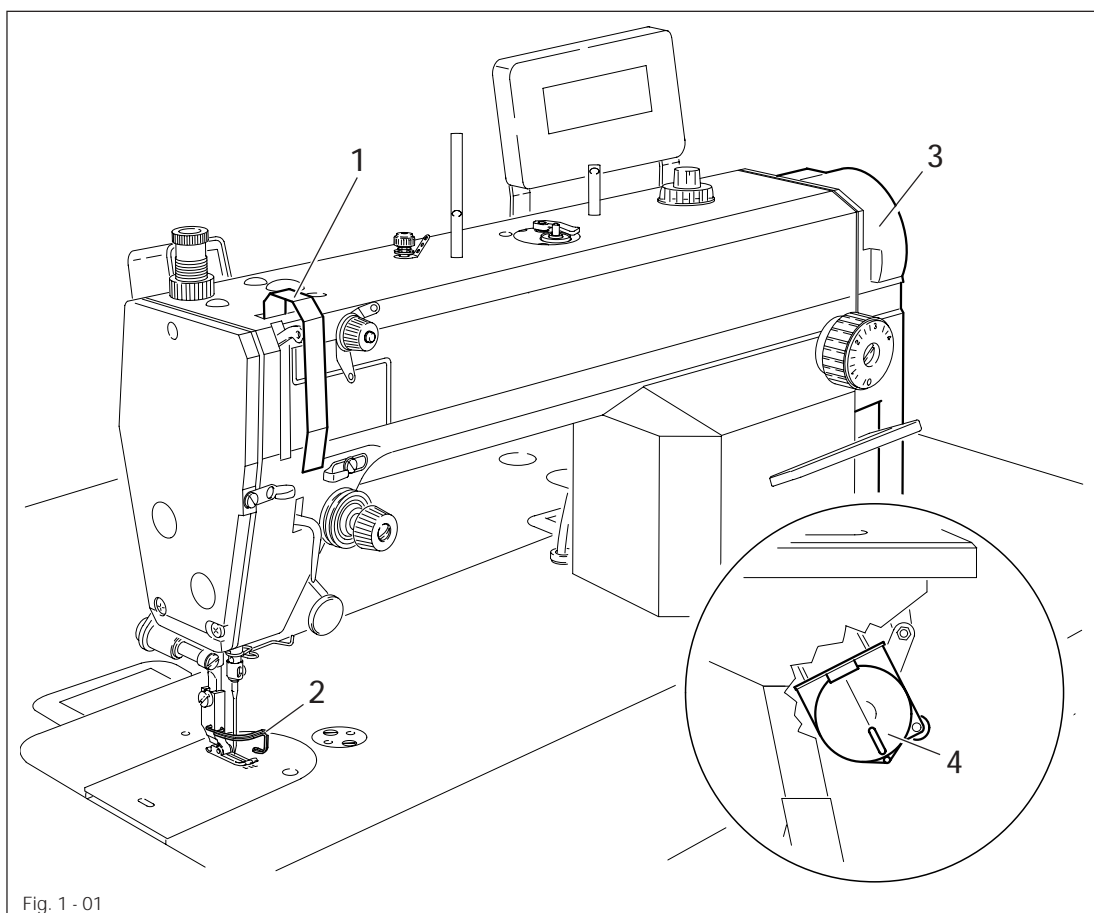

Fig. 1 - 01



Do not operate the machine without its take-up lever guard 1!
Danger of injury due to the motion of the take-up lever!



Do not operate the machine without the finger guard 2!
Danger of injury by the needle!



If an external motor is used, do not operate the machine without the belt guards 3 and 4!
Danger of injury by the drive belt!

2

Proper use

The PFAFF 1163 is a single-needle, high-speed sewing machine with bottom feed. The machine is used to manufacture lockstitch seams in the textile industry.



Any and all uses of this machine which have not been approved of by the manufacturer are considered to be inappropriate! The manufacturer cannot be held liable for any damage caused by the inappropriate use of the machine! The appropriate use of the machine includes the observance of all operational, adjustment, maintenance and repair measures required by the manufacturer!

3 Specifications

3.01 PFAFF 1163 ▲

Stitch type:	301 (lockstitch)
Needle system:	DBx1
Needle size (Nm) in 1/100 mm:	80 - 100
Handwheel eff. dia.:	65 mm
Clearance under roller presser:	6 - 13 mm
Clearance width:	262 mm
Clearance height:	132 mm
Bedplate dimensions:	476 x 178 mm
Sewing head dimensions:	
Length:	approx. 520 mm
Width:	approx. 180 mm
Height (above table):	approx. 250 mm
Max. stitch length:	5,0 mm
Max. speed:	5000 spm ♦
Connection data:	
Operating voltage:	230 V ± 10%, 50/60 Hz
Max. power consumption:	400 VA
Fuse protection:	1 x 16 A, inert
Working noise level:	
Emission level at workplace at a speed of 4000 spm:	$L_{pA} < 77$ dB(A) ■
(Noise measurement in accordance with DIN 45 635-48-A-1, ISO 11204, ISO 3744, ISO 4871)	
Net weight of sewing head:	approx. 24 kg
Gross weight of sewing head:	approx. 32 kg

▲ Subject to alteration

♦ Dependent on material, work operation and stitch length

■ $K_{pA} = 2,5$ dB

3.02 Models and subclasses

Model B: for work on medium-weight materials (standard parts set)

Work aids:

Sub-class -900/93 Thread trimmer

Sub-class -909/93 Thread wiper

Sub-class -910/93 Automatic presser foot lift

Sub-class -911/93 Backtacking mechanism

4 Disposal of machine

- The proper disposal of the machine is the responsibility of the customer.
- The materials used in the machines are steel, aluminium, brass and various plastics. The electrical equipment consists of plastics and copper.
- The machine is to be disposed of in accordance with the locally valid environmental protection regulations. If necessary, a specialist is to be commissioned.



Special care is to be taken that parts soiled with lubricants are separately disposed of in accordance with the locally valid pollution control regulations!

5 Transport, packaging and storage

5.01 Transport to the customer's premises

The machines are delivered completely packed.

5.02 Transport within the customer's premises

The manufacturer bears no liability for transport within the customer's premises or to the individual locations of use. Make sure that the machines are always transported upright.

5.03 Disposal of the packaging

The packaging of these machines consists of paper, cardboard and VCE fiber. The proper disposal of the packaging is the responsibility of the customer.

5.04 Storage

The machine can be stored for up to 6 months if not in use. During this time it should be protected from dust and moisture.

For longer storage the individual parts of the machine, especially the moving parts, must be protected from corrosion, e.g. by a film of oil.

6 Explanation of the symbols

In the following section of this Instruction Manual, certain tasks or important pieces of information are accentuated by symbols.

The symbols used have the following meanings:



Note, information



Cleaning, care



Lubrication, greasing

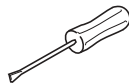

Servicing, repairing, adjustment, maintenance
(only to be carried out by specialist personnel)

7 Controls

7.01 On/Off switch

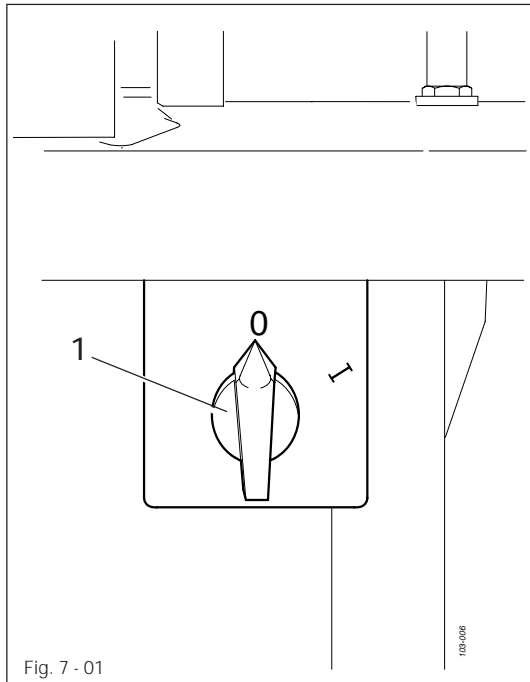

- Switch the machine on or off by turning main switch 1.

7.02 Pedal

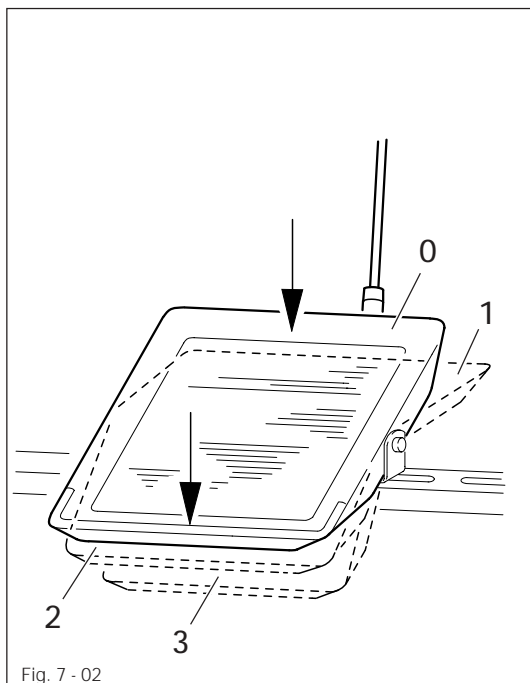

- 0 = Neutral position
- 1 = Sewing
- 2 = Raise presser foot (on machines with automatic presser foot lift -910/93)
- 3 = Trim thread (on machines with thread trimmer -900/93)

7.03 Lever for raising the presser foot

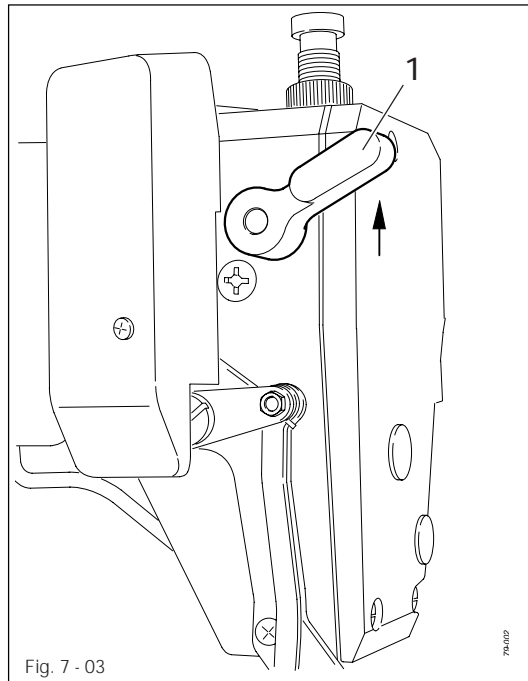

- Raise the presser foot by turning lever 1 in the direction of the arrow.

7.04 Knee lever

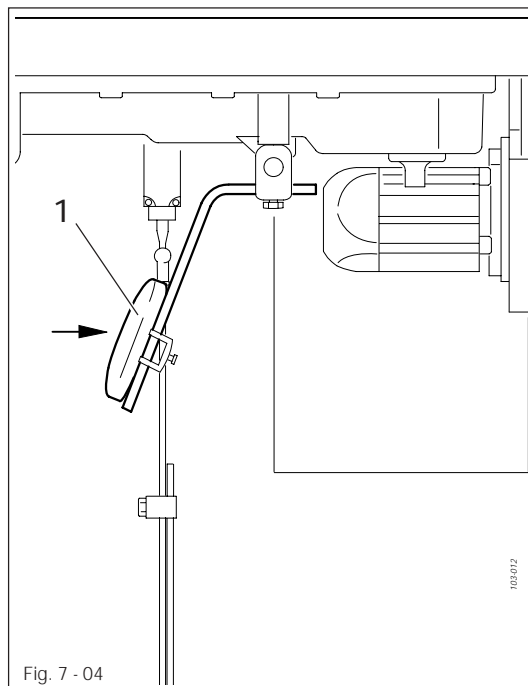

- By pressing the knee lever 1 in the direction of the arrow, the presser foot is raised.

7.05 Stitch length adjustment wheel

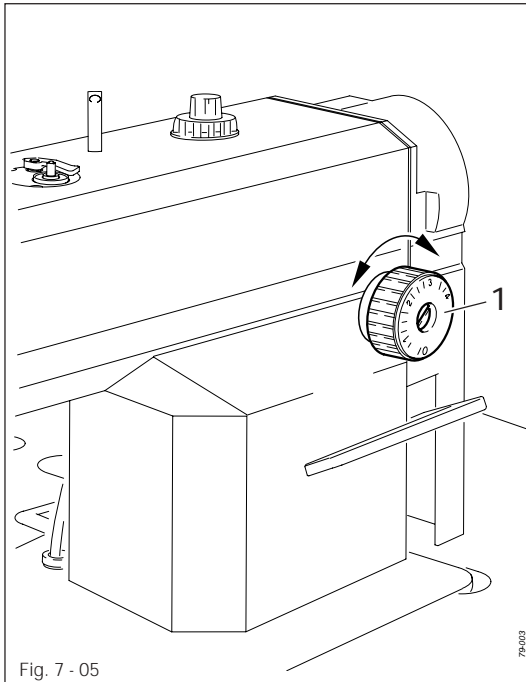

- Turn adjustment wheel 1 to set the required stitch length.

7.06 Reverse stitch key

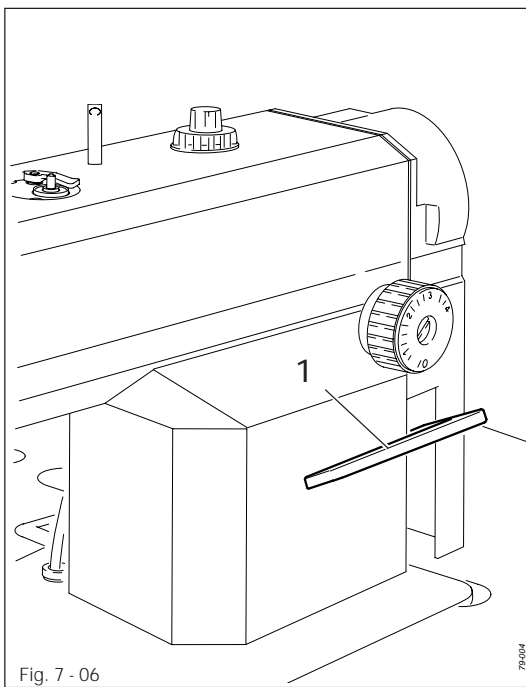

- For sewing in the reverse direction, key 1 must be pressed during sewing.

7.07 Key on machine head

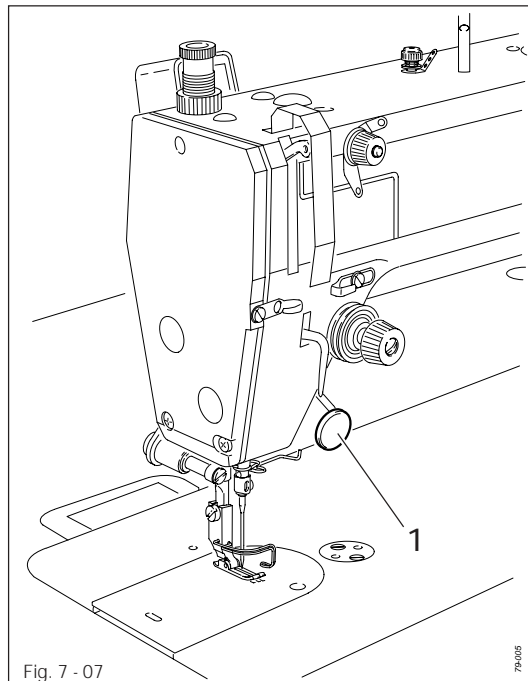

- By operating key 1 during sewing, the machine switches to reverse sewing (only on machines with backtacking mechanism -911/93).

7.08 Switch for thread wiper -909/93

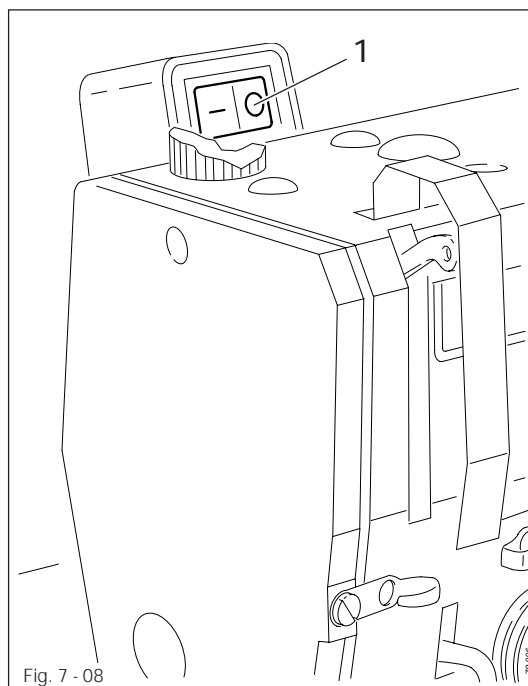

- The thread wiper can be switched on or off by pressing switch 1.

Position 1 : unit is switched on

Position 0 : unit is switched off

7.09 Control panel

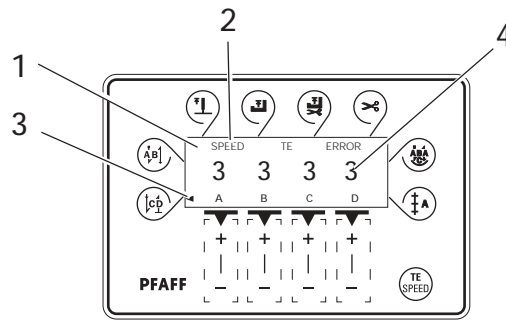

The control panel consists of display 1 and the function keys described below. The display 1 consists of a single-line alpha-numerical, 7 segment LCD display with 8 symbols. The texts 2, located above and next to the LCD display, show the respective status of the function keys and the operating status of the machine. The control panels switches on all LCD-segments and the horn automatically for a short time during the power-on phase, after which the lettering PFAFF appears on the display, until the higher-ranking control unit sends commands to the control panel.

The function keys are located around the display 1. They are foil-packed without permanent marking and without contact signal. Fixed functions are allocated to the keys, see **Chapter 7.09.02 Function keys**.

7.09.01 Screen displays

- Activated functions are displayed with a triangular marking 3 below or next to the respective function key.
- In the sewing mode all relevant sewing data is displayed and can be changed directly, depending on the status of the machine, see also **Chapter 10 Sewing**.
- During the parameter input the selected parameter number with the corresponding value is displayed, see **Chapter 13.09.02 Example of a parameter input**.

7.09.02 Function keys

The function keys described below are used basically to switch machine functions on and off.

Each time a key is pressed, this must be confirmed by at least one beep tone. Irrespective of the machine mode a double beep signal is given if invalid keys are pressed or maximum values reached.

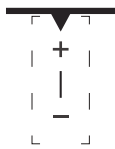

If a corresponding value has to be set for the activated function, this is carried out with the corresponding +/- key. By pressing and holding the corresponding +/- key, the relevant numerical value 4 is changed slowly to begin with. If the corresponding +/- key is held down longer, the values change more quickly.



Start backtacks

- If this key is pressed, the backtacks at the beginning of the seam (start backtacks) are switched on or off. The number of forward stitches (A) or reverse stitches (B) for the start backtacks can be changed by pressing the +/- key underneath. To convert from double backtack to single backtack set the number of stitches for the corresponding seam section at zero.



End backtacks

- If this key is pressed, the backtacks at the end of the seam (end backtacks) are switched on or off. The number of reverse stitches (C) or forward stitches (D) can be changed by pressing the +/- key underneath. To convert from double backtack to single backtack set the number of stitches for the corresponding seam section at zero.



Needle position

- If this key is pressed the „needle raised after sewing stop“ function is switched on or off. When the function is switched on, the needle positions at t.d.c. after sewing stops.



Foot position after stop

- If this key is pressed the „foot raised after sewing stop“ function is switched on or off. When the function is switched on, the presser foot is raised after sewing stops.



Foot position after trimming

- If this key is pressed the „foot raised after thread trimming“ function is switched on or off. When the function is switched on, the presser foot is raised after thread trimming.



Thread trimmer

- If this key is pressed the thread trimming function is switched on or off.



Darning program

- If this key is pressed the darning program function is switched on or off. The counted seam function is switched off automatically.



Counted seam

- If this key is pressed the counted seam function is switched on or off. The darning program function is switched off automatically.



TE/Speed

- If this key is pressed once the speed limit for the sewing mode is activated.
- If this key is pressed twice (within 5 seconds) the machine changes from sewing to input mode.

8 Mounting and commissioning the machine



The machine must only be mounted and commissioned by qualified personnel!
All relevant safety regulations are to be observed!



If the machine is delivered without a table, be sure that the frame and the table top which you intend to use can hold the weight of the machine and the motor. It must be ensured that the supporting structure is sufficiently sturdy, even during sewing operations.

8.01 Mounting

The necessary electricity supply must be available at the machine's location. Also, a stable and horizontal surface as well as adequate lighting are required at the location.



Depending on the type of table, the method of packaging used may require that the table top be lowered for transport. The following is a description of how to adjust the height of the table top.

8.01.01 Adjusting the table-top height

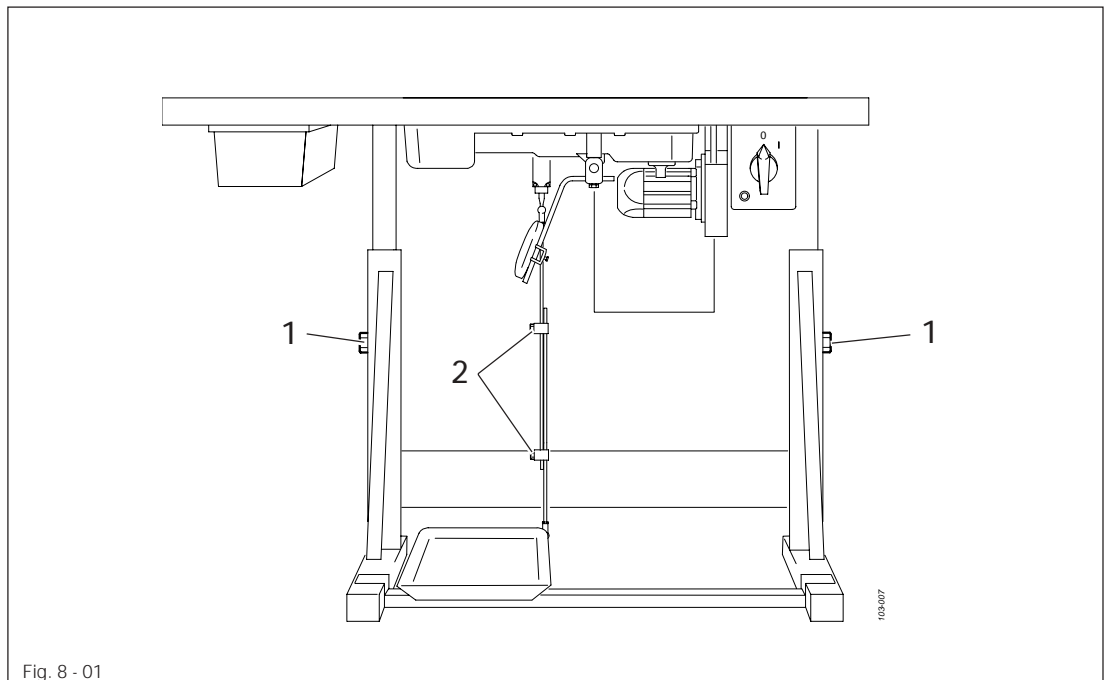

- Loosen screws 1 and 2 and set the desired table-top height
- Tighten screws 1 well.
- Adjust the pedal to the desired position and tighten screw 2.

8.01.02 Fitting the oil pan

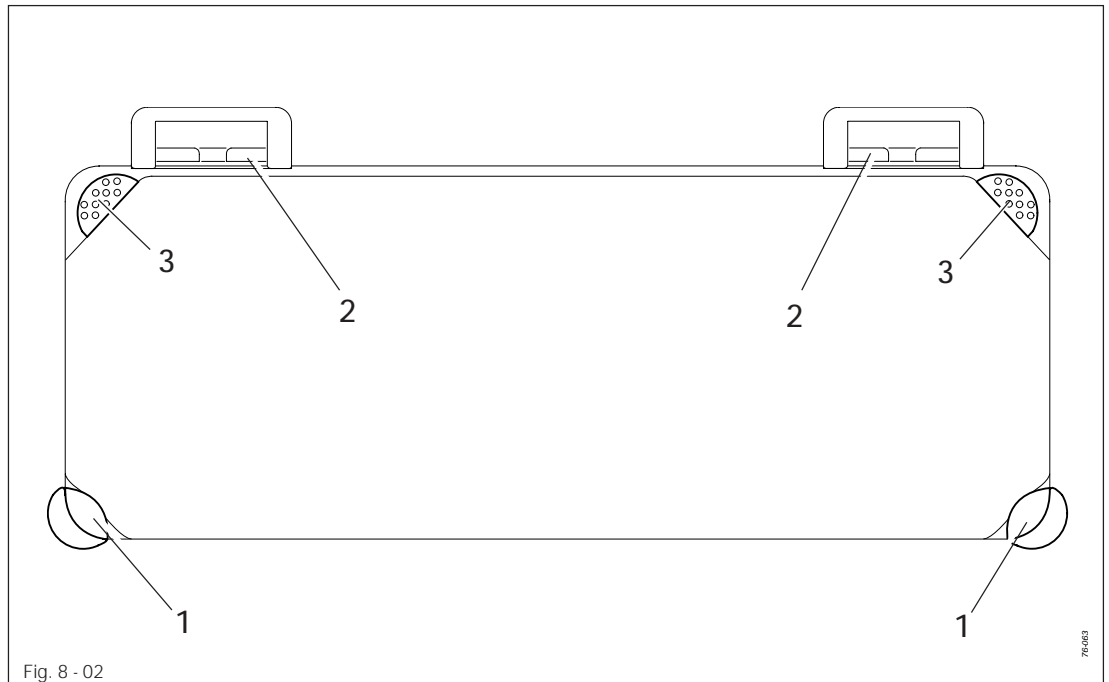

- Insert rubber pads 1 and 2 and fasten them with nails.
- Attach rubber pad 3 with a suitable adhesive.

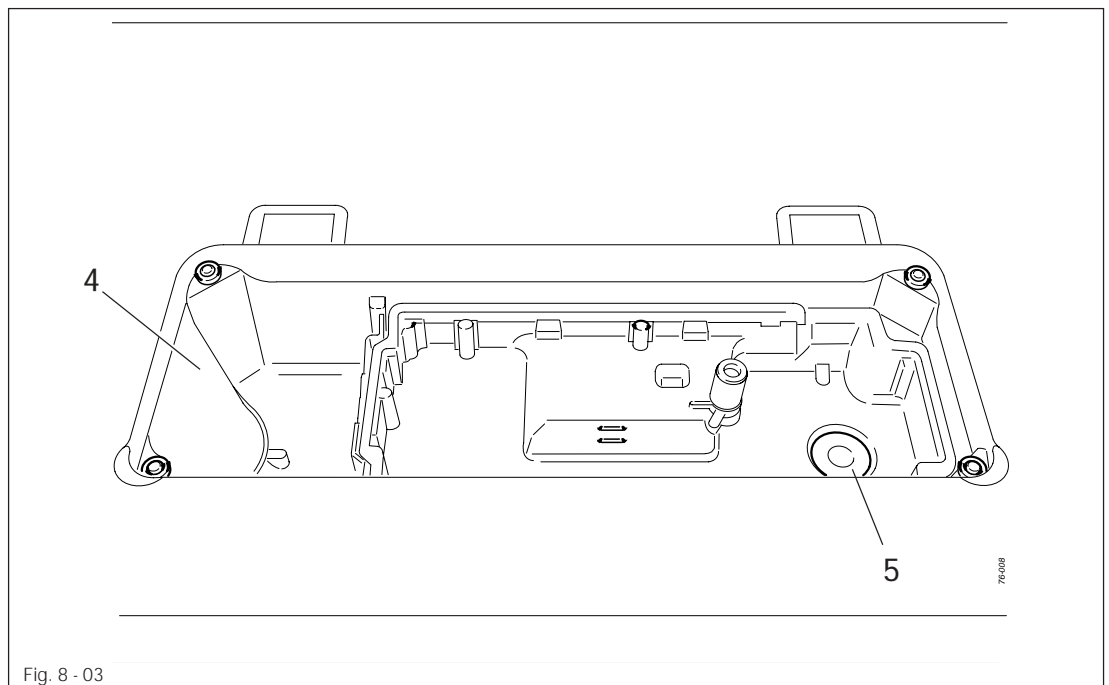

- Insert oil pan 4 in the table top cutout.
- Place magnet 5 in the corresponding recess of the oil pan.

Mounting and commissioning the machine

8.01.03 Mounting the sewing head

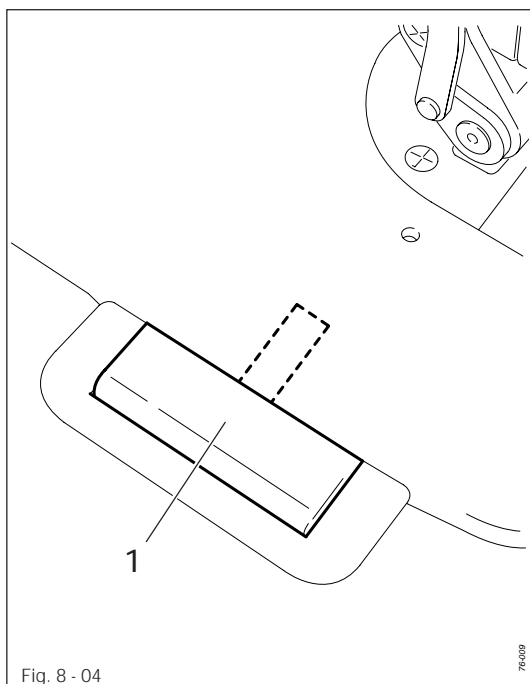

- Insert both hinges 1 in the corresponding holes in the bedplate of the sewing head.
- Insert the sewing head with hinges 1 into the rear rubber pads.

8.01.04 Mounting the balance wheel

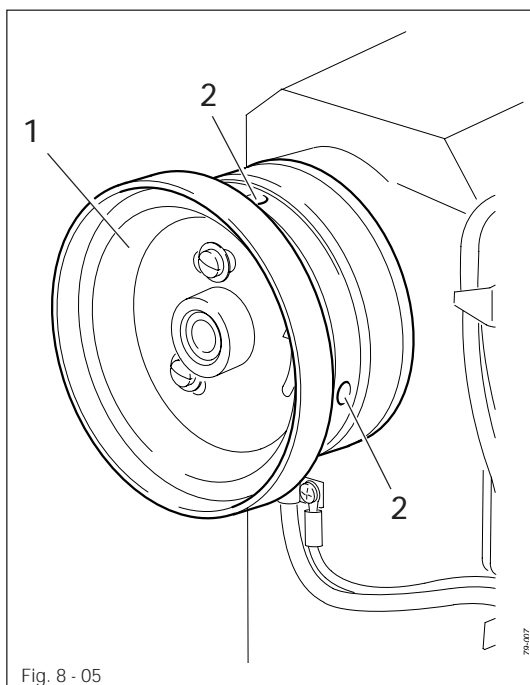

- Fit balance wheel 1 and fasten it with 2 screws 2.



The balance wheel must only be mounted on machines without a synchronizer.

8.01.05 Tightening the V-belt

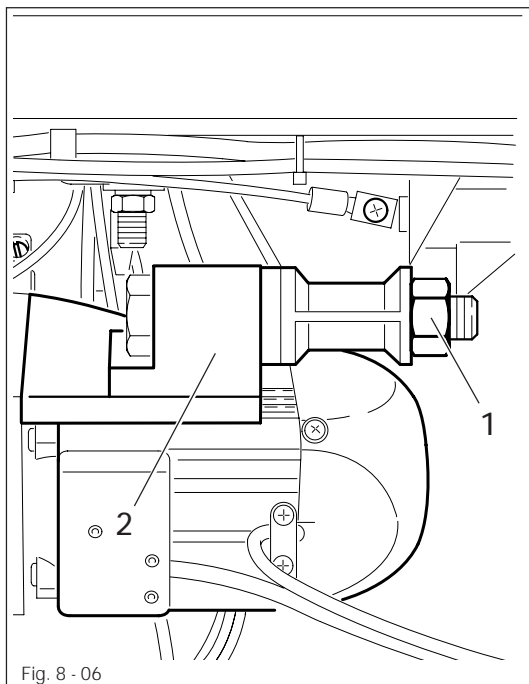

- Loosen nut 1 and tighten the V-belt by turning motor mounting 2.
- Tighten nuts 1.

8.01.06 Mounting the top V-belt guard

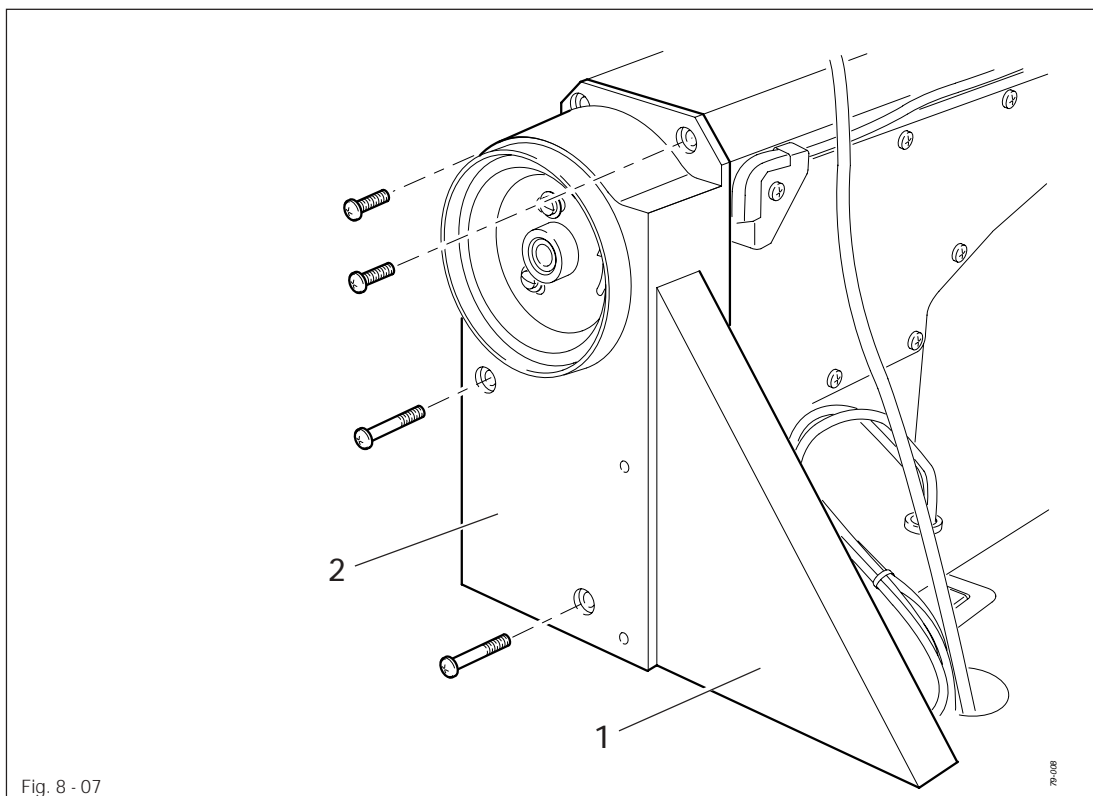

- Fasten part 1 of the V-belt guard to part 2 of the V-belt guard with 4 screws.
- Attach part 2 together with part 1 of the V-belt guard to the machine housing with 4 screws.

Mounting and commissioning the machine

8.01.07 Mounting the bottom V-belt guard

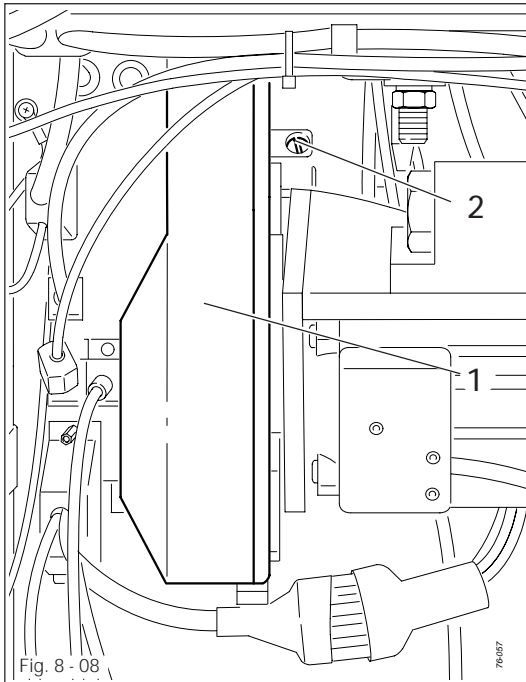

- Align V-belt guard 1 so that the motor pulley and V-belt are run freely.
- Tighten screw 2.

8.01.08 Fitting the thread guide

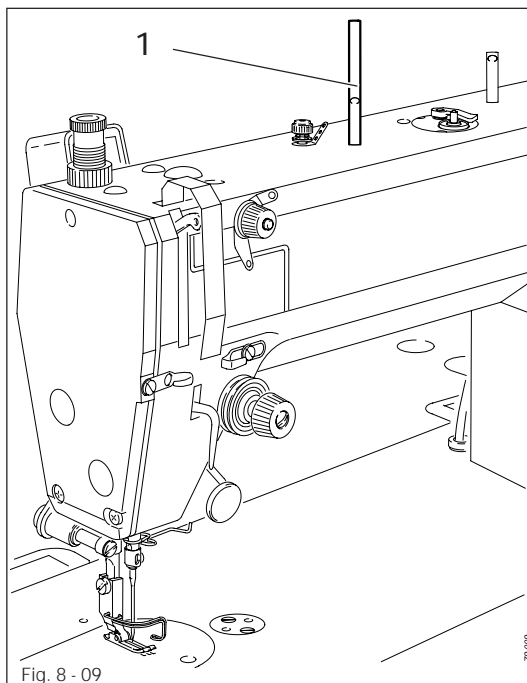

- Fit the tapered thread guide pin 1 into the corresponding hole in the machine housing.

8.01.09 Mounting the spool holder

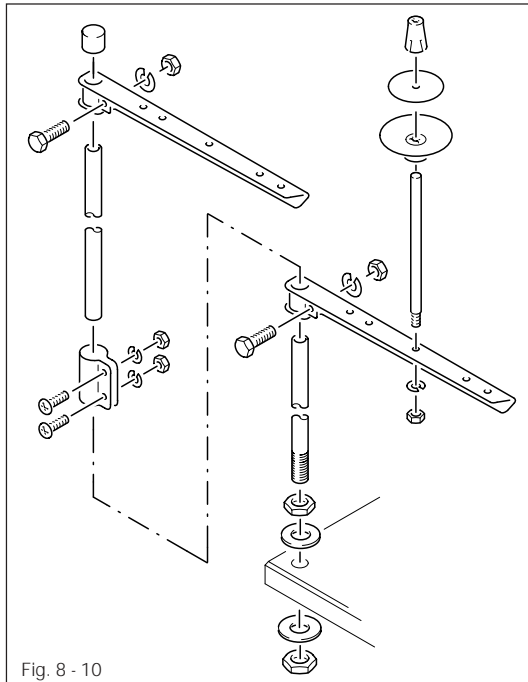

- Mount the spool holder as shown in Fig. 8-10.
- Insert the spool holder into the hole in the table top and fasten it with the nuts enclosed.

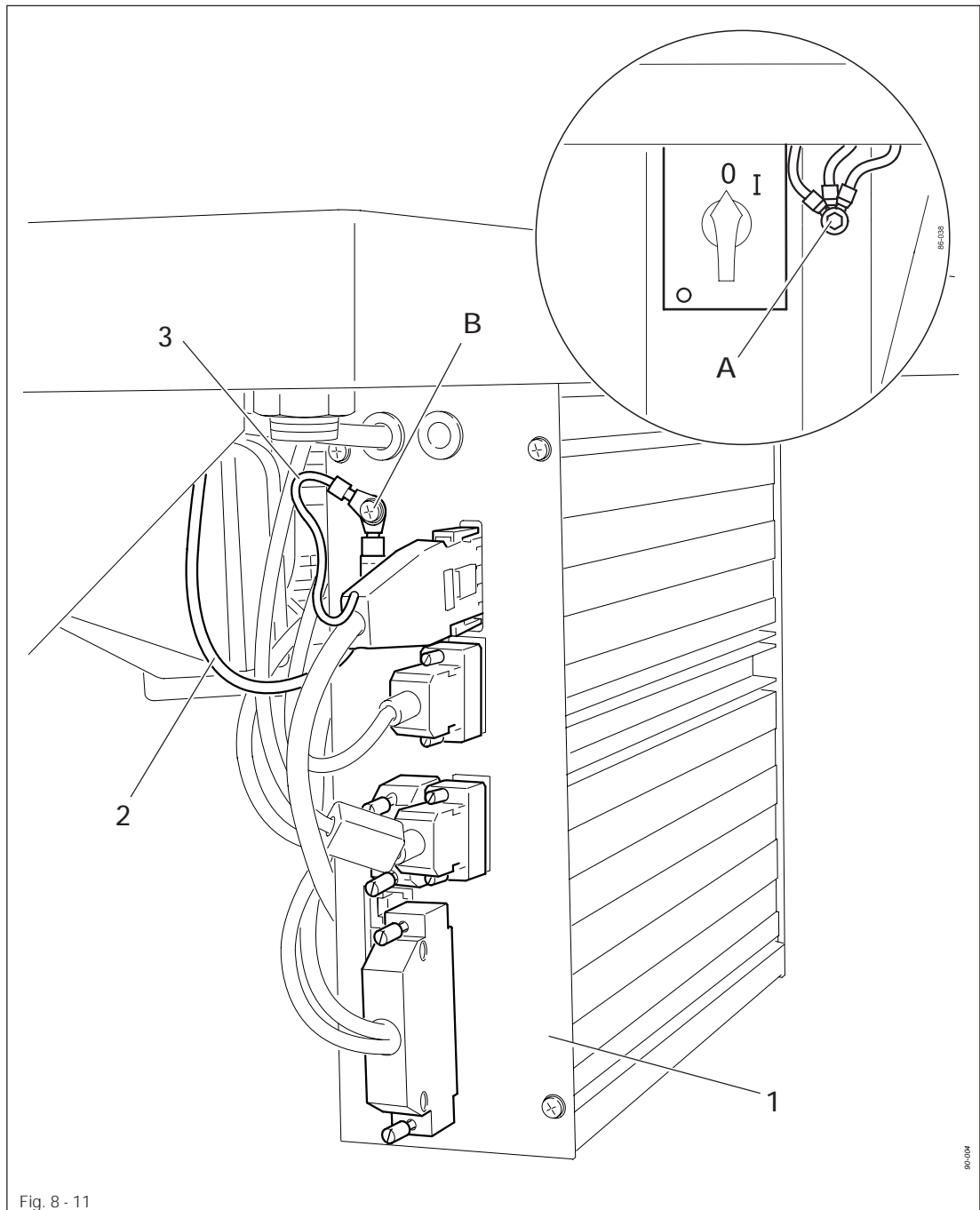

- Connect all plugs as labelled to the control box 1.
- Screw the earth cable from the sewing head and the main switch to earth point A.
- Connect earth point A to earth point B with earth cable 2.
- Screw the earth cable 3 from the motor to earth point B.

8.03 Commissioning



Before commissioning the machine, clean it thoroughly, fill the oil pan with oil and adjust the oil level, see **Chapter 10 Care and Maintenance!**

- Examine the machine, in particular the electric cables, for any damage.



Have qualified personnel check whether the machine can be operated with the available voltage and whether it is connected properly. If there are any irregularities do **not** operate the machine!



The machine may only be connected to an earthed socket!



When commissioning the machine or after a long period of non-operation, operate the machine with **max. 2000 spm** for the first 10 minutes! Danger of damage to the machine!

- When the machine is running, the balance wheel must turn towards the operator. If this is not the case, have the motor adjusted by qualified personnel, see Motor Service Manual.

8.04 Switching the machine on/off

- Switch the machine on or off in accordance with **Chapter 7.01 Main switch.**

8.05 Basic setting of the machine drive unit

- Switch on the machine.

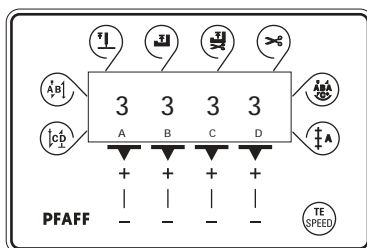

- Press TE/Speed key twice to call up the input mode.

Mounting and commissioning the machine

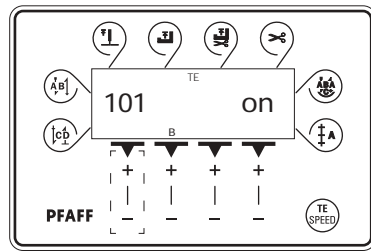
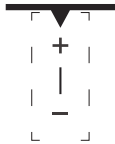

- By pressing the corresponding +/- key, call up parameter "798" and select service level "C", see Chapter 13.09.01 Selecting the user level

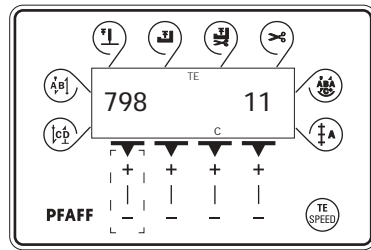

- By pressing the corresponding +/- key, call up parameter "800" (rotation direction of the motor).
- By pressing the corresponding +/- key enter the value "1".

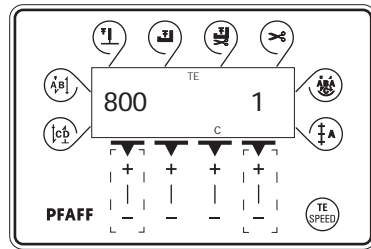

- By pressing the corresponding +/- key select parameter "700".

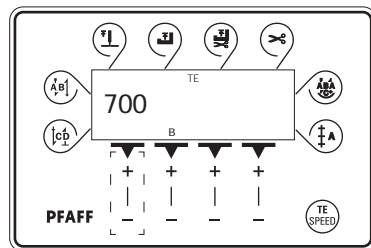

- Sew one stitch by operating the pedal.
 - Turn the balance wheel in the direction of sewing until the tip of the needle is level with the top edge of the needle plate.
-  ● Conclude the adjustment of the sewing motor by pressing the TE/Speed key.



The adjustment described above only applies to machines with Eco-Drive!
When using another type of motor, please observe the motor instruction manual of the manufacturer.

8.06 Table top cutout

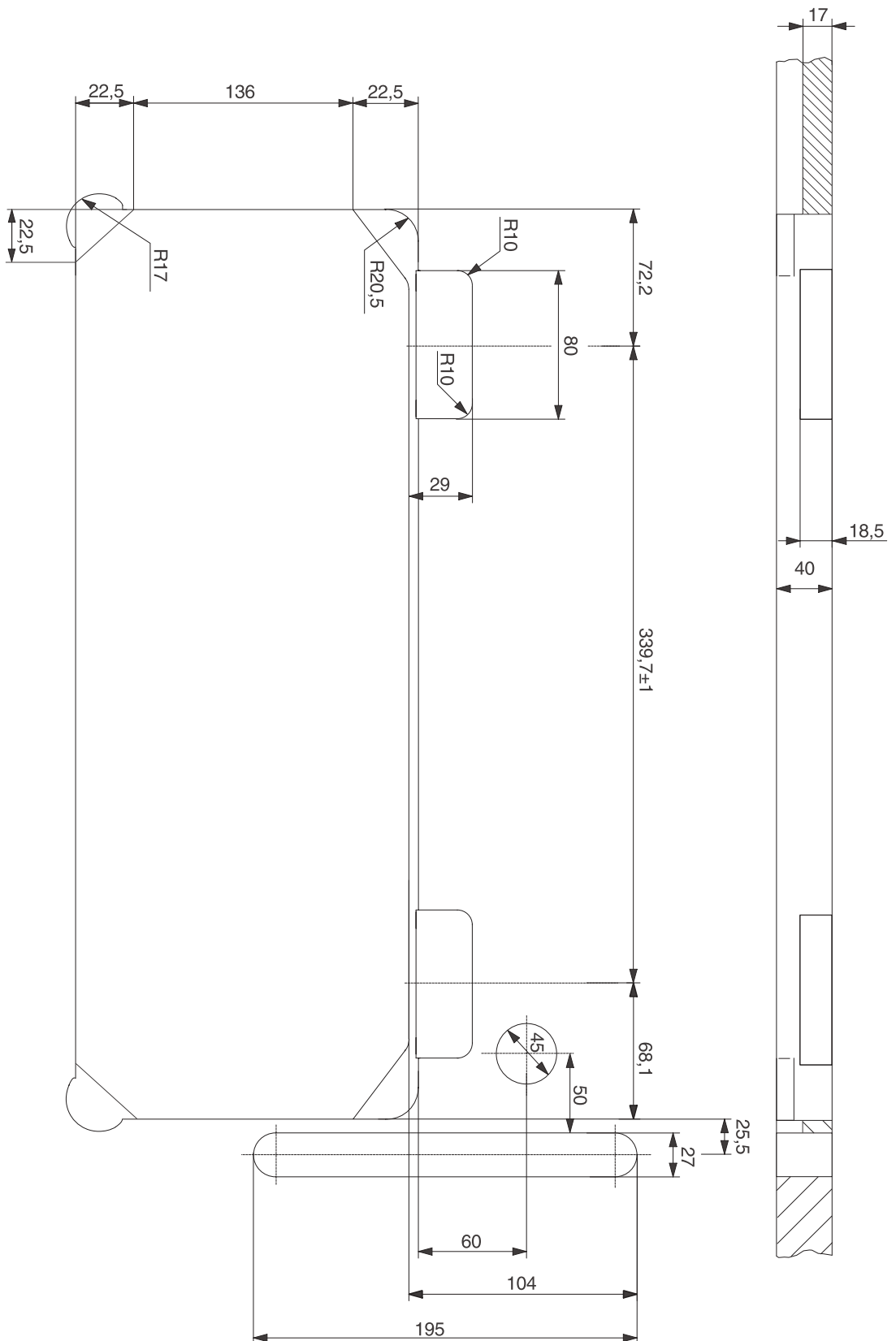

9

Preparation



All regulations and instructions in this Instruction Manual are to be observed!
Special attention is to be paid to the safety regulations!



All preparation work is only to be carried out by appropriately trained personnel.
Before all preparation work, the machine is to be separated from the electricity supply by removing the plug from the mains or switching off the On/Off switch!

9.01

Inserting the needle

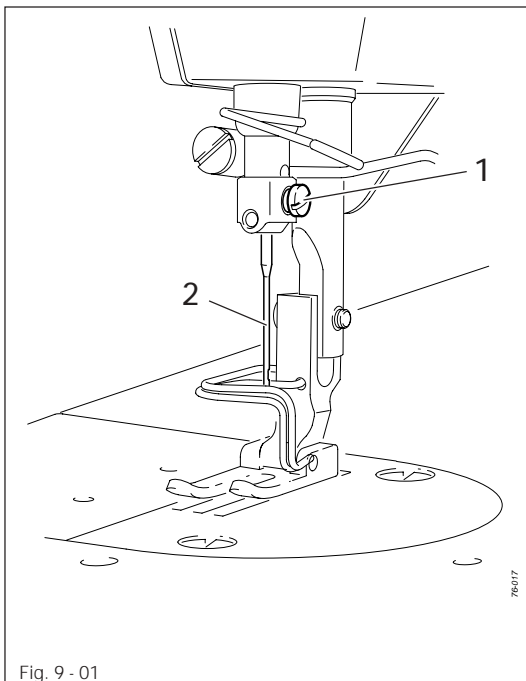

Switch off the machine!
Danger of injury due to
unintentional starting of the
machine!



Only use needles of system
DBx1.

- Raise needle bar.
- Loosen screw 1 and insert needle 2 until you feel it stop.
- Tighten screw 1.

9.02 Winding the bobbin thread / adjusting the preliminary thread tension

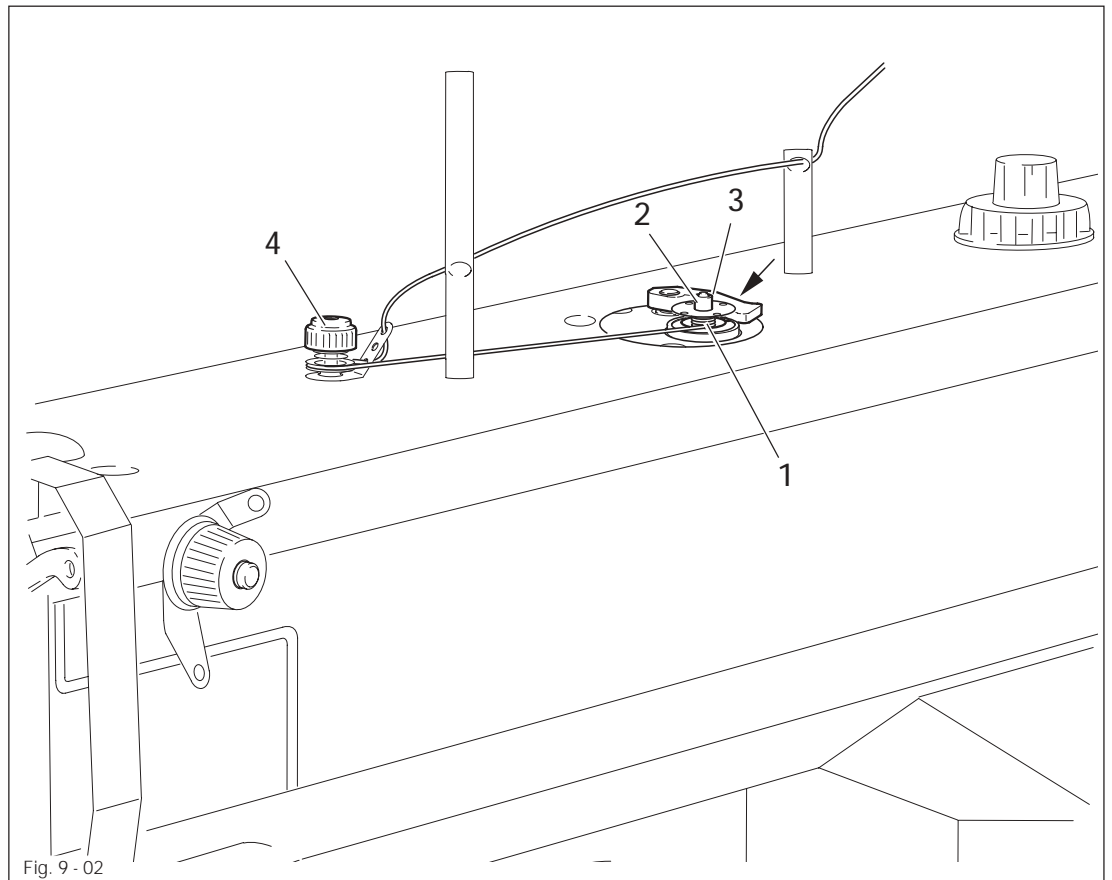

Fig. 9 - 02

- Place empty bobbin 1 on the bobbin winder spindle 2.
- Thread the thread as shown in Fig. 9.02 and wind it around the bobbin 1 a few times in a clockwise direction.
- Switch on the bobbin winder by pressing lever 3 in the direction of the arrow.



Bobbin 1 is filled during sewing.

- The tension of the thread on bobbin 1 can be adjusted with milled screw 4.
- The bobbin winder stops automatically, when bobbin 1 is sufficiently full.
- To adjust the amount of thread turn the screw on lever 3.

9.03 Removing/Inserting the bobbin case

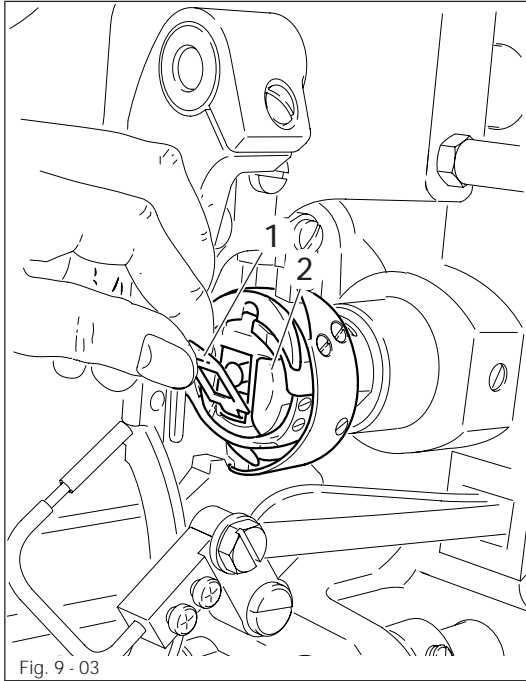

Switch off the machine!
Danger of injury due to
unintentional starting of the
machine!

Removing the bobbin case:

- Tilt back the machine.
- Raise latch 1 and remove bobbin case 2.

Inserting the bobbin case:

- Press bobbin case 2 until you feel it snap into the bobbin case base.



Return the machine to its
upright position using **both**
hands!
Danger of injury by crushing
between the machine and the
table top!

9.04 Inserting the bobbin case / Adjusting the bobbin thread tension

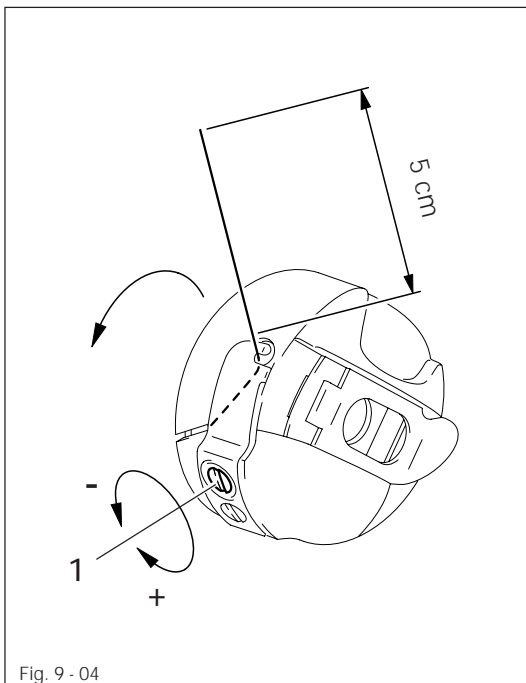

- Insert the bobbin into the bobbin case.
- Pass the thread through the slot under the spring according to Fig. 9-04.
- Adjust the thread tension by turning screw 1.

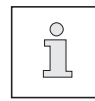

When the thread is pulled, the
bobbin must rotate in the
direction of the arrow.

9.05 Threading the needle thread / adjusting the needle thread tension

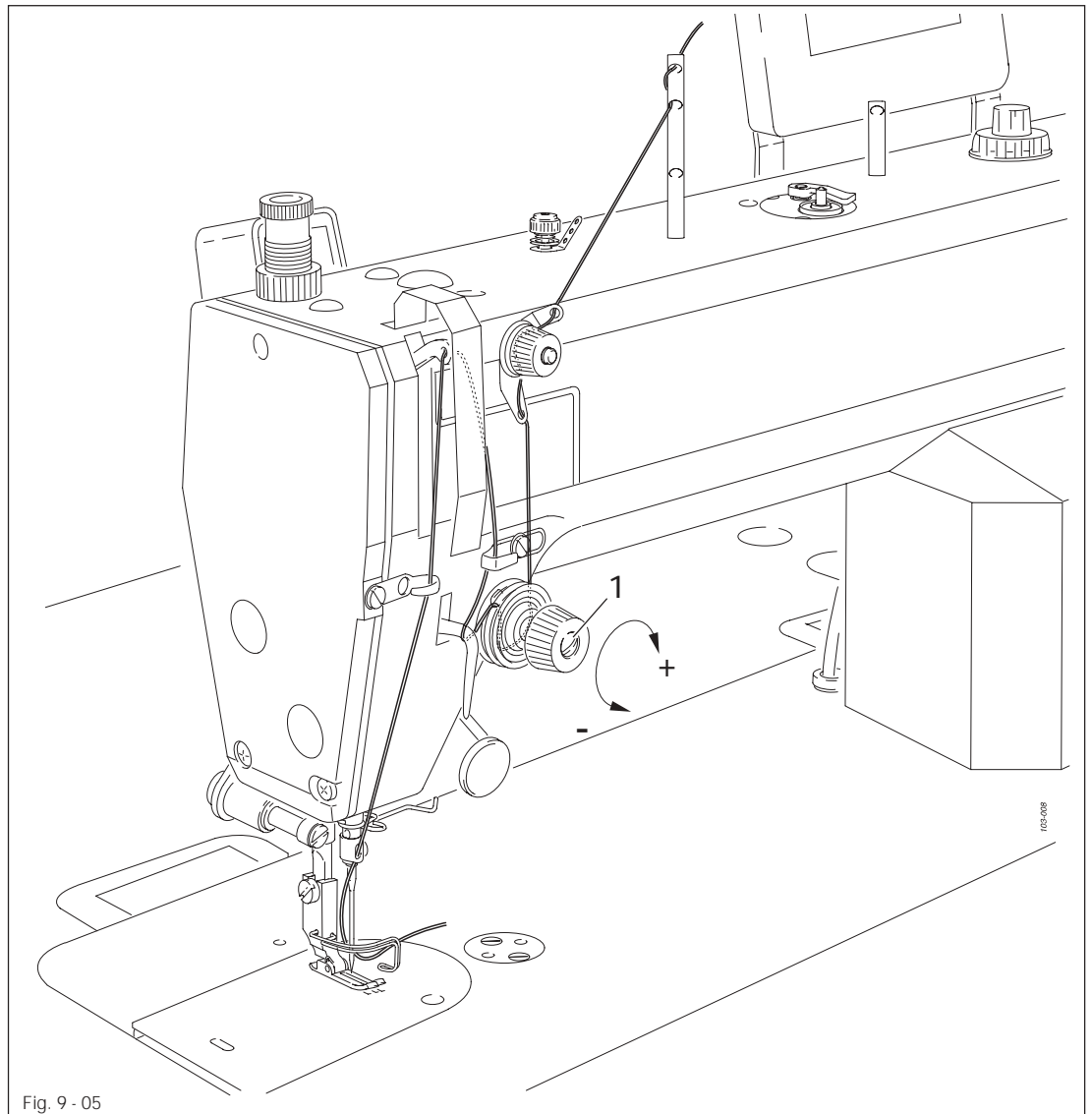

Switch off the machine.
Danger of injury if the machine is started accidentally!

- Thread the needle thread as shown in Fig. 9.05.
- Adjust the needle thread tension by turning adjustment wheel 1.

9.06 Entering the start and end backtacks

- Switch on the machine.

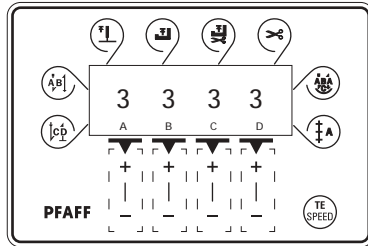

- If necessary switch off the "darning seam" or "counted seam" function, see **Chapter 10.01 Darning program** or **Chapter 10.02 Counted seam**.
- By pressing the corresponding +/- key ("A") select the desired value for the number of forward stitches (A) of the start backtack.
- By pressing the corresponding +/- key ("B") select the desired value for the number of reverse stitches (B) of the start backtack.
- By pressing the corresponding +/- key ("C") select the desired value for the number of reverse stitches (C) of the end backtack.
- By pressing the corresponding +/- key ("D") select the desired value for the number of forward stitches (D) of the end backtack.
- By pressing the keys **start backtack** and/or **end backtack**, activate the corresponding function (arrow appears next to the corresponding function key).

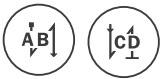

10 Sewing

In the sewing mode all relevant settings for the sewing operation are displayed. Functions can be switched on or off by pressing a key. Values for start and end backtacks or stitch placement can be changed directly.



When the machine is switched on, the sewing mode is always activated.

- Switch on the machine.

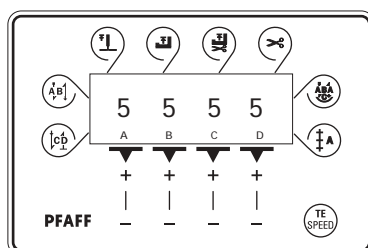

- If necessary switch off the function "darning seam" or "counted seam", see [Chapter 10.01 Darning program](#) or [Chapter 10.02 Counted seam](#).

Functions in manual sewing, also see [Chapter 7.09.02 Function keys](#):

	Start backtacks on/off		Presser foot raised at end of seam on/off
	End backtacks on/off		Thread trimming on/off
	Needle position raised on/off		Darning program on/off
	Presser foot raised on/off		Counted seam on/off

Sewing is carried out with the pedal functions, see [Chapter 7.02 Pedal](#).



The "Darning program" and "Counted seam" functions are explained in more detail in [Chapter 10.01 Darning program](#) or [Chapter 10.02 Counted seam](#).

10.01 Darning program

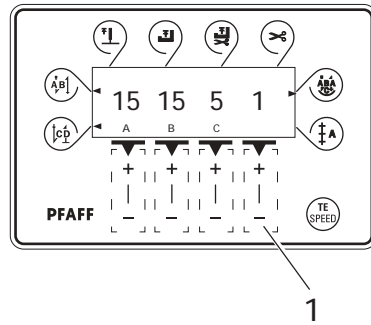

The corresponding function can be switched on or off directly with the **Darning program** key. The "counted seam" function is switched off automatically. Several darning programs with different seam sections A and/or B can be selected. The number of required darning programs can be selected by operating the +/- key **1**. The number of stitches for the individual seam sections A and/or B can be selected by operating the **corresponding +/- key**. By operating the **corresponding +/- key** it is possible to select a repeating factor "C" for the selected darning program.

If the backtack functions are also activated, only the status backtack on or backtack off is displayed. The individual backtack parameters can be altered after the "darning program" function has been switched off, see **Chapter 9.06 Entering start and end backtacks**.

10.02 Counted seam

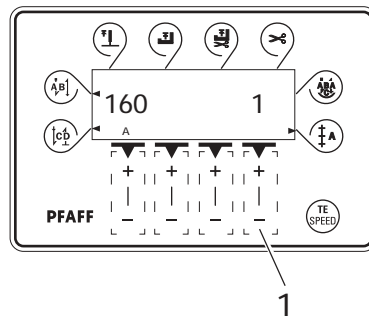

The corresponding function can be switched on or off directly with the **Counted seam** key. The "darning program" function is switched off automatically. Several counted seam sections can be selected. The number of required seam sections can be selected by operating the +/- key **1**. The required number of stitches "A" of the selected seam section can be selected by operating the **corresponding +/- key**.

If the backtack functions are also activated, only the status backtack on or backtack off is displayed. The individual backtack parameters can be altered after the "counted seam" function has been switched off, see **Chapter 9.06 Entering start and end backtacks**.

10.03 Error messages

If a fault occurs, the text "ERROR" appears on the display, together with an error code and short instructions. An error message is caused by incorrect settings, faulty elements or seam programs as well as by overload conditions.

For an explanation of the error codes see **Chapter 13.11 Explanation of the error messages**.

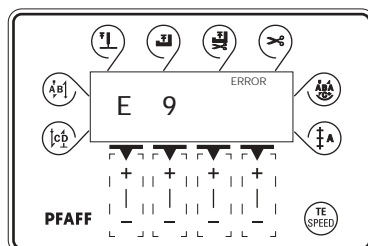

- Correct the error.
- Acknowledge error correction by pressing the TE/Speed key.



11 Care and maintenance

Cleaning	daily, several times if in continuous use
Checking the oil level	once a month [▲]



▲ These maintenance intervals are calculated for the average running time of a single shift operation. If the machine is operated more than this, shorter intervals are recommended.

11.01 Cleaning the machine

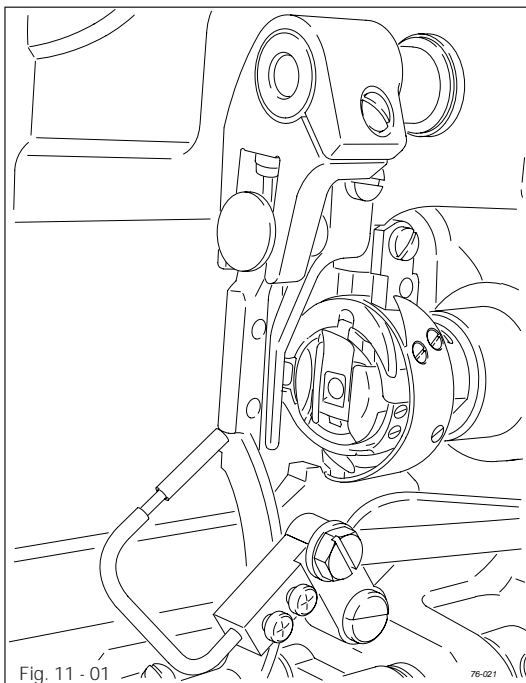

Switch off the machine!
Danger of injury due to unintentional starting of the machine!

- Tilt back the machine.
- Clean the hook and hook compartment daily, more often if in continuous operation.



Return the machine to its upright position using **both** hands!
Danger of injury by crushing between the edge of the machine and the table top!

11.02 Checking the oil level / filling in oil

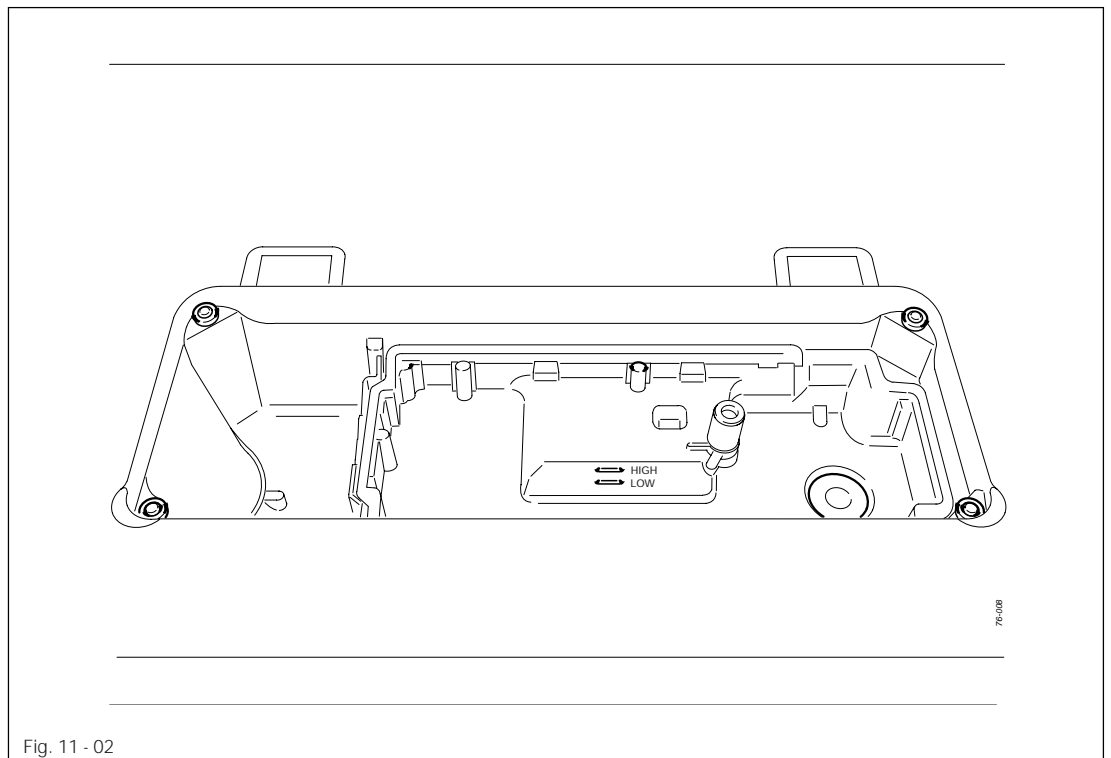

The oil level must always be between the markings "High" and "Low".

- Switch off the machine.
- Tilt the machine back and check the oil level.
- If necessary fill in oil up to the marking "High".



When commissioning the machine or after a long period of non-operation, operate the machine with **max. 2000 spm** for the first 10 minutes! Danger of damage to the machine!



Set the machine upright with **both** hands!
Danger of crushing between machine head and table top.



Only use oil with a mean viscosity of 10.0 mm²/s at 40°C and a density of 0.847 g/cm³ at 15°.

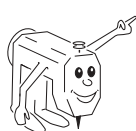

We recommend PFAFF sewing machine oil, part no. 280-1-120 105.

11.03 Adjusting the lubrication

11.03.01 Lubricating the needle head parts

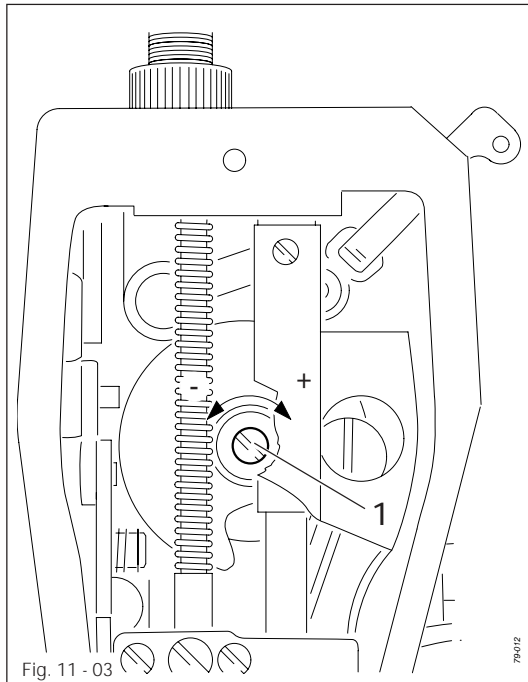

- The needle head parts should be adequately lubricated without oil dripping out of the head part.
- The amount of oil for lubricating the head parts is adjusted by turning screw 1.

11.03.02 Hook lubrication

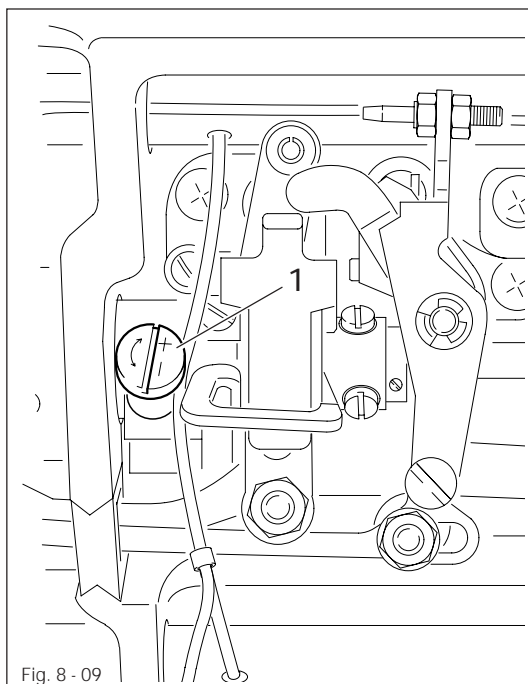

The following adjustments may only be carried out by appropriately trained personnel.

- Remove the needle.
- Dismount the needle plate and bottom feed dog.
- Place a sheet of paper over the needle plate cutout and start the machine running.
- If a thin streak of oil is visible on the paper after a running time of approx. 10 seconds at top speed, the hook lubrication is set correctly.
- To adjust the amount of oil, turn adjustment screw 1.

Wearing parts



This is a list of the most important wearing parts.

A detailed parts list for the complete machine is included with the accessories.

In case of loss, the parts list can be downloaded from the internet address www.pfaff-industrial.com/de/service/download/index.php3. As an alternative to the internet download the parts lists can also be ordered in book form under part no. 296-12-18 608.

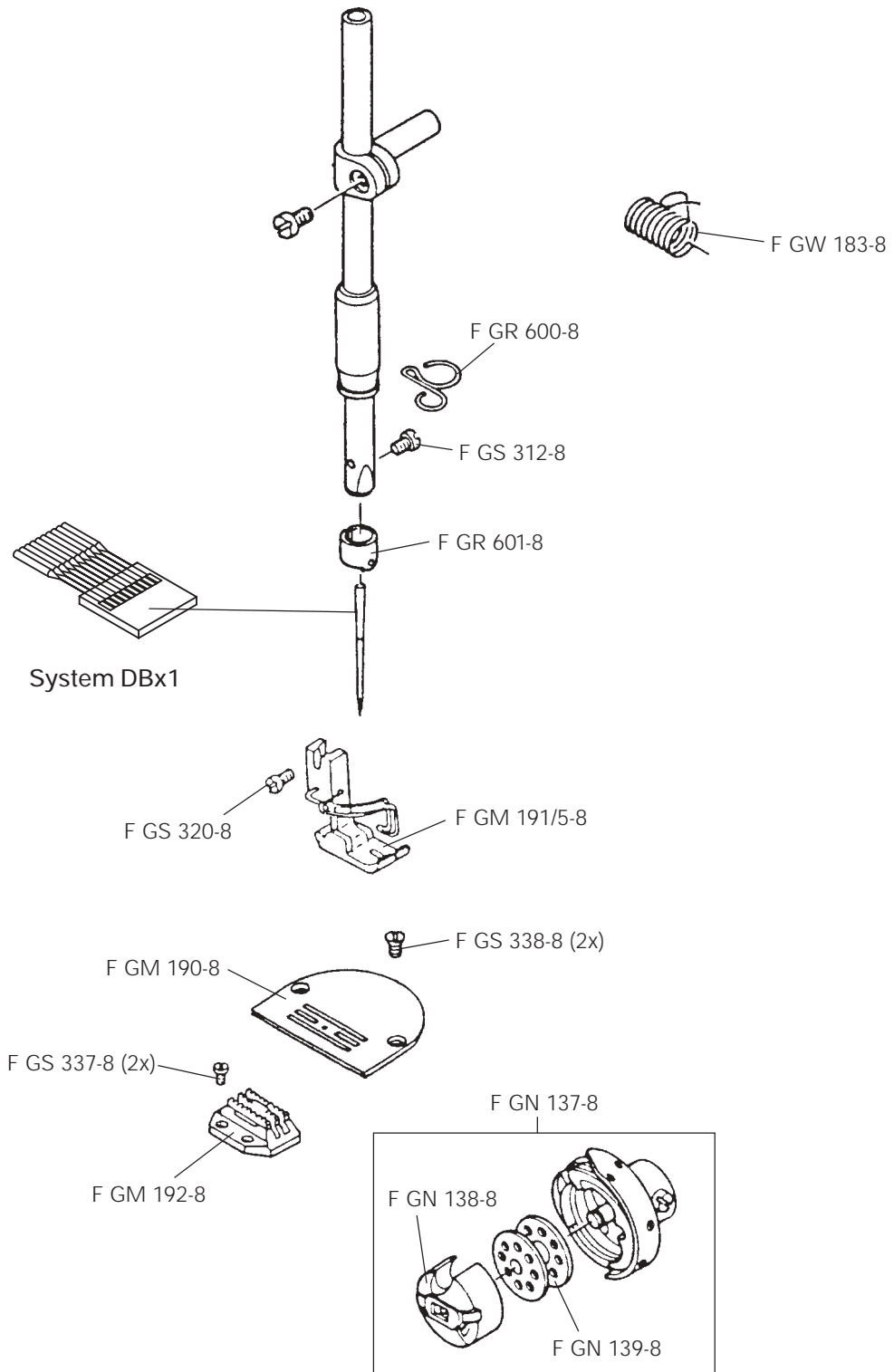

Wearing parts

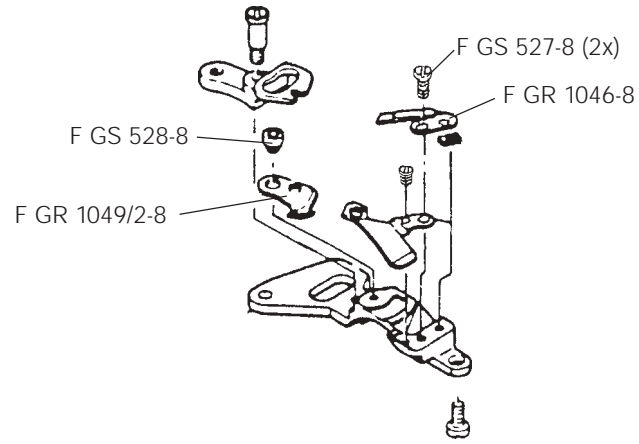

PFAFF

PFAFF Industrie Maschinen AG

Postfach 3020
D-67653 Kaiserslautern

Königstr. 154
D-67655 Kaiserslautern

Telefon: (0631) 200-0
Telefax: (0631) 17202
E-Mail: info@pfaff-industrial.com