

# PFAFF

471

474

Instruction Manual

491

This instruction manual applies to machines from the following serial numbers onwards:

PFAFF	471	#	2560474	→
PFAFF	474	#	2561194	→
PFAFF	491	#	2561421	→



This instruction manual applies to all versions and subclasses listed under "**Specifications**".

Reprinting, copying or translation of PFAFF instruction manuals, whether in whole or in part, is not permitted without our prior permission and not without written indication of the source.

**G.M. PFAFF KAISERSLAUTERN  
INDUSTRIEMASCHINEN AG**

Postfach 3020  
D-67653 Kaiserslautern

Königstr. 154  
D-67655 Kaiserslautern

Editing/illustrations  
Verlag TD  
D-77901 Lahr

Contents .....		Chapter - Page
<b>1</b>	<b>Safety</b> .....	<b>1 - 1</b>
1.01	Directives .....	1 - 1
1.02	General notes on safety .....	1 - 1
1.03	Safety symbols .....	1 - 2
1.04	Important points for the user .....	1 - 2
1.05	Operating and specialist personnel .....	1 - 3
1.05.01	Operating personnel .....	1 - 3
1.05.02	Specialist personnel .....	1 - 3
1.06	Danger .....	1 - 4
<b>2</b>	<b>Proper use</b> .....	<b>2 - 1</b>
<b>3</b>	<b>Specifications</b> .....	<b>3 - 1</b>
3.01	PFAFF 471, 474, 491 .....	3 - 1
3.02	Needles and threads .....	3 - 2
3.03	Possible models and subclasses .....	3 - 2
<b>4</b>	<b>Disposal of Machine</b> .....	<b>4 - 1</b>
<b>5</b>	<b>Transportation, packing and storage</b> .....	<b>5 - 1</b>
5.01	Transportation to customer's premises .....	5 - 1
5.02	Transportation inside the customer's premises .....	5 - 1
5.03	Disposal of packing materials .....	5 - 1
5.04	Storage .....	5 - 1
<b>6</b>	<b>Explanation of symbols</b> .....	<b>6 - 1</b>
<b>7</b>	<b>Controls</b> .....	<b>7 - 1</b>
7.01	On / off switch on machines with mini-stop motor without edge trimmer -725/.. or -726/.. .....	7 - 1
7.02	On / off switch on machines with mini-stop motor and edge trimmer -725/.. or -726/.. .....	7 - 1
7.03	Button on machine head (only on machines with -911/..) .....	7 - 2
7.04	Pedal .....	7 - 2
7.05	Lever for lifting roller presser .....	7 - 3
7.06	Knee lever .....	7 - 3
7.07	Key for setting stitch length .....	7 - 4
7.08	Swing out roller presser .....	7 - 4
7.09	Edge trimmer -725/04 for 471 .....	7 - 5
7.10	Edge trimmer -725/04 for 474 and 491 .....	7 - 6
7.11	Edge trimmer -726/05 for 491 .....	7 - 7
<b>8</b>	<b>Installation and commissioning</b> .....	<b>8 - 1</b>
8.01	Installation .....	8 - 1
8.01.01	Adjusting the table height .....	8 - 1
8.01.02	Fitting the tilt lock .....	8 - 2
8.01.03	Tensioning the v-belt (does not apply to machines with mini-stop motor) .....	8 - 2
8.01.04	Fitting the v-belt guard .....	8 - 3
8.01.05	Fitting the bottom v-belt guard (does not apply to machines with mini-stop motor) .....	8 - 3
8.01.06	Fitting the synchronizer .....	8 - 4
8.01.07	Fitting the reel stand .....	8 - 4
8.02	Commissioning .....	8 - 5

	Contents .....	Chapter - Page
8.03	Switching the machine on / off .....	8 - 5
<b>9</b>	<b>Setting up</b> .....	<b>9 - 1</b>
9.01	Inserting the needle on model 471 and 491 .....	9 - 1
9.02	Inserting the needle on model 474 .....	9 - 2
9.03	Winding the bobbin thread; adjusting the primary thread tension .....	9 - 3
9.04	Removing / Inserting the bobbin case .....	9 - 4
9.05	Threading the bobbin case / Adjusting the bobbin thread tension .....	9 - 4
9.06	Threading the needle thread and regulating its tension on model 471/491 .....	9 - 5
9.07	Threading the needle thread and regulating its tension on model 474 .....	9 - 6
9.08	Setting the stitch length .....	9 - 7
<b>10</b>	<b>Care and maintenance</b> .....	<b>10 - 1</b>
10.01	Cleaning .....	10 - 1
10.02	Oiling the hook .....	10 - 2
10.03	Filling the oil reservoir of the thread lubrication unit .....	10 - 3
10.04	Lubricating the bevel gears .....	10 - 3
10.05	Checking / adjusting the air pressure .....	10 - 4
10.06	Cleaning the air filter of the air-filter / lubricator .....	10 - 4
<b>11</b>	<b>Adjustment</b> .....	<b>11 - 1</b>
11.01	Notes on adjustment .....	11 - 1
11.02	Tools, gauges and other accessories .....	11 - 1
11.03	Abbreviations .....	11 - 1
<b>11.04</b>	<b>Adjusting the basic machine</b> .....	<b>11 - 2</b>
11.04.01	Adjusting the synchronizer .....	11 - 2
11.04.02	Needle position in sewing direction on the PFAFF 471 and 491 .....	11 - 3
11.04.03	Needle position in sewing direction on the PFAFF 474 .....	11 - 4
11.04.04	Preliminary adjustment of the needle height .....	11 - 5
11.04.05	Needle rise, hook clearance, needle height and needle guard on the PFAFF 471 .....	11 - 6
11.04.06	Needle rise, hook clearance, needle height and needle guard on the PFAFF 474 .....	11 - 8
11.04.07	Needle rise, hook clearance, needle height and needle guard on the PFAFF 491 .....	11 - 10
11.04.08	Needle position crosswise to sewing direction on the PFAFF 471 .....	11 - 12
11.04.09	Needle position crosswise to sewing direction on the PFAFF 474 .....	11 - 13
11.04.10	Needle position crosswise to sewing direction on the PFAFF 491 .....	11 - 14
11.04.11	Height of the bobbin-case opener .....	11 - 15
11.04.12	Bobbin-case opener stroke .....	11 - 16
11.04.13	Height of the feed wheel on the PFAFF 471 .....	11 - 17
11.04.14	Height of the feed wheel on the PFAFF 474 .....	11 - 18
11.04.15	Height of the feed wheel on the PFAFF 491 .....	11 - 19
11.04.16	Stitch length control eccentric .....	11 - 20
11.04.17	Stitch length scale disk .....	11 - 21
11.04.18	Shaft crank to feed wheel drive .....	11 - 22
11.04.19	Shaft crank to roller presser drive .....	11 - 23
11.04.20	Clearance between roller presser and feed wheel .....	11 - 24
11.04.21	Roller presser .....	11 - 25
11.04.22	Stitch length on stitch length scale .....	11 - 26
11.04.23	Synchronization of roller presser and feed wheel .....	11 - 27
11.04.24	Retainer (only on model 474) .....	11 - 28
11.04.25	Knee lever .....	11 - 29

	Chapter - Page
Contents .....	11 - 30
11.04.26 Needle thread tension release .....	11 - 30
11.04.27 Thread check spring .....	11 - 31
11.04.28 Bobbin winder .....	11 - 32
11.04.29 Pressure of roller presser .....	11 - 33
11.04.30 Re-engage safety coupling .....	11 - 34
<b>11.05 Adjusting the edge trimmer -725/04 .....</b>	<b>11 - 35</b>
11.05.01 Position knife holder on model 471 .....	11 - 35
11.05.02 Position knife holder on models 474 and 491 .....	11 - 36
11.05.03 Knife stroke on model 471 .....	11 - 37
11.05.04 Knife stroke on models 474 and 491 .....	11 - 38
11.05.05 Cutting stroke on model 471 .....	11 - 39
11.05.06 Cutting stroke on models 474 and 491 .....	11 - 40
11.05.07 Knife position .....	11 - 41
<b>11.06 Adjusting the thread trimmer -726/05 on model 491 .....</b>	<b>11 - 42</b>
11.06.01 Position of the knife to the needle plate .....	11 - 42
11.06.02 Knife position crosswise to sewing direction .....	11 - 43
11.06.03 Knife height .....	11 - 44
11.06.04 Cutting stroke .....	11 - 45
11.06.05 Knife stroke .....	11 - 46
<b>11.07 Adjusting the thread trimmer -900/53 .....</b>	<b>11 - 47</b>
11.07.01 Removing the cutter .....	11 - 47
11.07.02 Control cam with respect to bobbin opener and tripping lever .....	11 - 48
11.07.03 Radial position of the tripping lever .....	11 - 49
11.07.04 Engaging solenoid .....	11 - 50
11.07.05 Cutter drive lever .....	11 - 51
11.07.06 Control cams for bobbin opener and cutter (using adjustment gauge) .....	11 - 52
11.07.07 Radial position of the control cam in relation to the bobbin opener .....	11 - 53
11.07.08 Control cam for cutter (adjustment without gauge) .....	11 - 54
11.07.09 Cutter control lever for the control cam of the cutter .....	11 - 55
11.07.10 Cutter return lever .....	11 - 56
11.07.11 Cutter return control .....	11 - 57
11.07.12 Fitting the cutter .....	11 - 58
11.07.13 Eccentric sleeve .....	11 - 59
11.07.14 Cutter driving rod .....	11 - 60
11.07.15 Cutter function test .....	11 - 61
<b>11.08 Tension release (only on machines with thread tension control -906/10) .....</b>	<b>11 - 63</b>
<b>11.09 Adjustment of backtacking mechanism -911/.. .....</b>	<b>11 - 64</b>
11.09.01 Needle in needle hole (only for PFAFF 471 and 491) .....	11 - 64
11.09.02 Coupling for roller presser drive .....	11 - 65
11.09.03 Bevel gears for feed wheel drive (on the PFAFF 471 and 474) .....	11 - 66
11.09.04 Bevel gear play (on the PFAFF 471 and 474) .....	11 - 67
11.09.05 Bevel gears for feed wheel drive (on the PFAFF 491) .....	11 - 68
11.09.06 Bevel gear play (on the PFAFF 491) .....	11 - 69
<b>11.10 Parameter settings for the Quick-Ministop Motor .....</b>	<b>11 - 70</b>

## 1 Safety

### 1.01 Directives

This machine is constructed in accordance with the European regulations contained in the conformity and manufacturer's declarations.

In addition to this Instruction Manual, observe also all generally accepted, statutory and other regulations and legal requirements and all valid environmental protection regulations! The regionally valid regulations of the social insurance society for occupational accidents or other supervisory organisations are to be strictly adhered to!

### 1.02 General notes on safety

- This machine may only be operated by adequately trained operators and only after the Instruction Manual has been completely read and understood!
- All Notes on Safety and Instruction Manuals of the motor manufacturer are to be read before operating the machine!
- The danger and safety instructions on the machine itself are to be followed!
- This machine may only be used for the purpose for which it is intended and may not be operated without its safety devices. All safety regulations relevant to its operation are to be adhered to.
- When exchanging sewing tools (e.g. needle, roller presser, needle plate or bobbin), when threading the machine, when leaving the machine unattended and during maintenance work, the machine is to be separated from the power supply by switching off the On/Off switch or by removing the plug from the mains!
- Everyday maintenance work is only to be carried out by appropriately trained personnel!
- Repairs and special maintenance work may only be carried out by qualified service staff or appropriately trained personnel!
- Work on electrical equipment may only be carried out by appropriately trained personnel!
- Work is not permitted on parts and equipment which are connected to the power supply! Exceptions to this are only to be found in the regulations EN 50110.
- Modifications and alterations to the machine may only be carried out under observance of all the relevant safety regulations!
- Only spare parts which have been approved by us are to be used for repairs! We expressly point out that any replacement parts or accessories, which are not supplied by us, have not been tested and approved by us. The installation and/or use of any such products can lead to negative changes in the structural characteristics of the machine. We shall not be liable for any damage which may be caused by non-original parts.

### 1.03 Safety symbols



Danger!  
Points to be observed.



Danger of injury for operating and specialist personnel!



#### Caution

Do not operate without finger guard and safety devices.  
Before threading, changing bobbin and needle, cleaning etc. switch off main switch.

### 1.04 Important points for the user

- This Instruction Manual is a component part of the machine and must be available to the operating personnel at all times.
- The Instruction Manual must be read before operating the machine for the first time.
- The operating and specialist personnel is to be instructed as to the safety equipment of the machine and regarding safe work methods.
- It is the duty of the user to only operate the machine in perfect running order.
- It is the obligation of the user to ensure that none of the safety mechanisms are removed or deactivated.
- It is the obligation of the user to ensure that only authorized persons operate and work on the machine.

Further information can be obtained from your PFAFF agent.

## 1.05 Operating and specialist personnel

### 1.05.01 Operating personnel

Operating personnel are persons responsible for the equipping, operating and cleaning of the machine as well as taking care of faults arising in the sewing area.

The operating personnel is obliged to observe the following points and must:

- always observe the Notes on Safety in the Instruction Manual!
- never use any working methods which could limit the level of safety in using the machine!
- not wear loose-fitting clothing or jewellery such as chains or rings!
- also ensure that only authorized persons have access to the potentially dangerous area around the machine!
- always immediately report to the person responsible any changes in the machine which may limit its safety!

### 1.05.02 Specialist personnel

Specialist personnel are persons with a specialist education in the fields of electrics, electronics and mechanics. They are responsible for the lubrication, maintenance, repair and adjustment of the machine.

The specialist personnel is obliged to observe the following points and must:

- always observe the Notes on Safety in the Instruction Manual!
- switch off the On/Off switch before carrying out adjustments or repairs and ensure that it cannot be switched on again unintentionally!
- never work on parts which are still connected to the power supply! Exceptions are contained only in the regulations EN 50110.
- replace the protective coverings and close the electrical control box after all repairs or maintenance work!



1.06

Danger



A working area of 1 meter is to be kept free both in front of and behind the machine while it is in operation so that it is always easily accessible.



Never reach into the sewing area while sewing! Danger of injury by the needle!



Never leave objects on the table while adjusting the machine settings!  
Objects can become trapped or be slung away! Danger of injury!



Switch the machine off before tilting it backwards!  
Danger of injury if the machine is started accidentally!

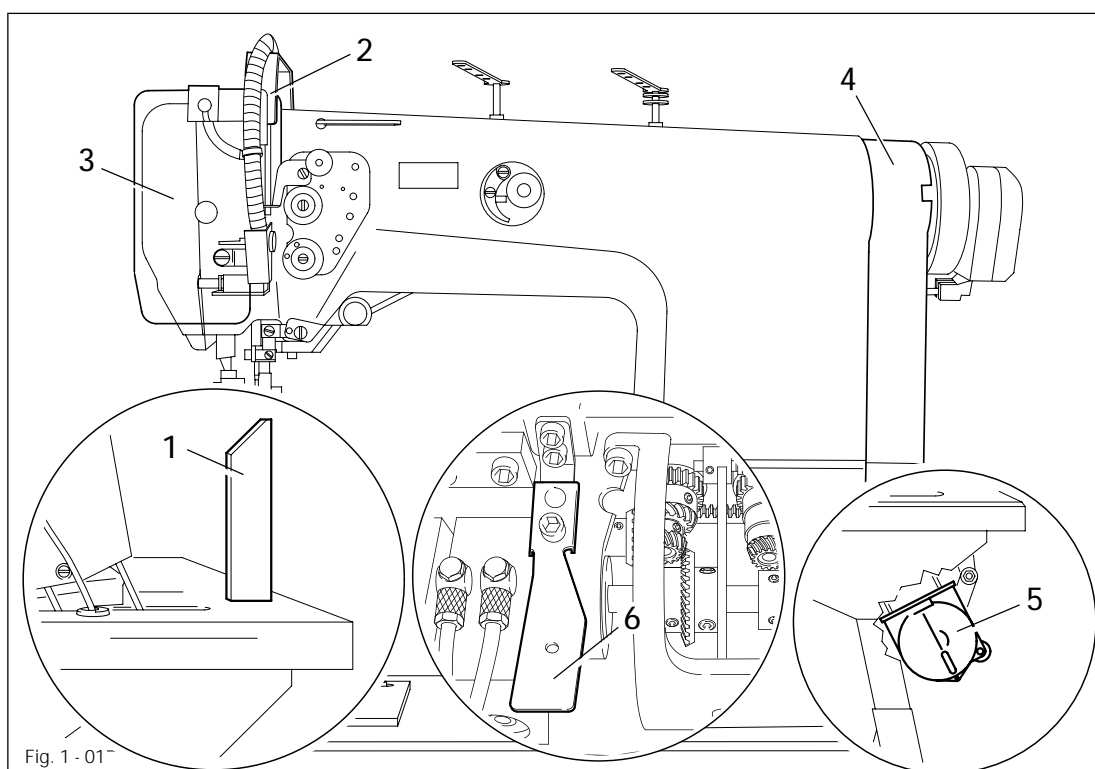

Do not operate the machine without support 1! Danger due to top-heavy sewing head! Machine can tip over backwards when tilted!



Do not operate the machine without its take-up-lever guard 2!  
Danger of injury due to the motion of the take-up lever!



On machines with thread lubricator, only operate the machine with the eye guard 3 lowered!  
The eye guard 3 protects the eyes from oil particles from the thread lubrication.



Do not operate the machine without belt guard 4 and 5!  
Danger of injury by rotating drive belt!



Do not operate the machine without tilt lock 6!  
Danger of crushing between sewing head and table top!

2

### Proper use

The PFAFF 471 is a single needle, high-speed post bed sewing machine (post to the left of the needle) with driven feed wheel and roller presser and synchronized needle.

The PFAFF 474 is a two-needle, high-speed post bed sewing machine with driven feed wheel and roller presser

The PFAFF 491 is a single needle, high-speed post bed sewing machine (post to the right of the needle) with driven feed wheel and roller presser and synchronized needle.

The machines are used for sewing lockstitch seams in the leather and upholstery industries.



Any use of these machines which is not approved by the manufacturer shall be considered as improper use! The manufacturer shall not be liable for any damage arising out of improper use! Proper use shall also be considered to include compliance with the operation, adjustment, service and repair measures specified by the manufacturer!

3 Specifications

3.01 PFAFF 471, 474 , 491 ▲

Stitch type: ..... 301 (lockstitch)

Balance wheel eff. diameter: ..... 65 mm

Fabric clearance (roller presser raised): ..... 7 mm

Clearance width: ..... 245 mm

Clearance height: ..... 115 mm

Post height: ..... 180 mm

Dimensions of sewing head:

Length: ..... approx. 615 mm

Width: ..... approx. 240 mm

Height (above table): ..... approx. 450 mm

Size of bedplate: ..... 518 x 177 mm

Max. speed:

Model A + B ..... 2800 stiches/min ♦

Model B/C ..... 2500 stiches/min ♦

Trimming margin (for -725/.. and -726/..): ..... 0.8 - 2.5 mm

Trimming speed (for -725/.. and -726/..): ..... 2800 cuts/min

Connection data:

Operating voltage: ..... 230 V ± 10%, 50/60 Hz

Max. power consumption: ..... 1.2 kVA

Fuse protection: ..... 1 x 16 A, delayed action

Working noise level:

Emission at workplace

PFAFF 471 and 491 models A + B n = 2200 spm: ..... 80 dB(A)

PFAFF 471 and 491 models B/C n = 2000 spm: ..... 78 dB(A)

PFAFF 474 model B n = 2200 spm: ..... 81 dB(A)

PFAFF 474 model B/C n = 2000 spm: ..... 79 dB(A)

( Noise measurement in accordance with DIN 45 635-48-A-1 )

Net weight of sewing head: ..... approx. 53 kg

Gross weight of sewing head: ..... approx. 61 kg

▲ Subject to alteration

♦ Dependent on material, working cycle and stitch length

# Specifications

## 3.02 Needles and threads

Model	Thread strength <sup>▲</sup> (Nm) max. synthetic	Needle size in 1/100 mm	Needle system for PFAFF 471 and 491	Needle system for the PFAFF 474
A	60/3	70	134	-
B	40/3	100	134	134 - 35
B/C	20/3	120	134	134 - 35

▲ or similar strengths of other types of thread

## 3.03 Possible models and subclasses

Model A ..... For sewing lightweight materials

Model B ..... For sewing medium-weight materials

Model B/C ..... For sewing medium- to medium-heavy materials

Additional equipment:

Subclass -725/04 ..... Edge trimmer

Subclass -726/05 ..... Edge trimmer

Subclass -900/53 ..... Thread trimmer

Subclass -906/10 ..... Thread tensioner

Subclass -910/15 ..... Automatic presser foot lifter

Subclass -911/35 ..... Bartacker

### 4 Disposal of Machine

- Proper disposal of the machine is the responsibility of the customer.
- The materials used for the machine are steel, aluminium, brass and various plastic materials.  
The electrical equipment comprises plastic materials and copper.
- The machine is to be disposed of according to the locally valid pollution control regulations; if necessary, a specialist is to be commissioned.



Care must be taken that parts soiled with lubricants are disposed of separately according to the locally valid pollution control regulations!

### 5 Transportation, packing and storage

#### 5.01 Transportation to customer's premises

Within the Federal Republic of Germany, complete machines (with table and motor) are delivered without packing.

Machines without table (only sewing heads) and machines intended for export are packed.

#### 5.02 Transportation inside the customer's premises

The manufacturer cannot be made liable for transportation inside the customer's premises nor to other operating locations. It must be ensured that the machines are only transported in an upright position.

#### 5.03 Disposal of packing materials

The packing materials of this machine comprise paper, cardboard and VCE fibre. Proper disposal of the packing material is the responsibility of the customer.

#### 5.04 Storage

If the machine is not in use, it can be stored as it is for a period of up to six months, but It should be protected against dust and moisture.

If the machine is stored for longer periods, the individual parts, especially the surfaces of moving parts, must be protected against corrosion, e.g. by a film of oil.

### 6 Explanation of symbols

In this instruction manual, work to be carried out or important information is accentuated by symbols. These symbols have the following meanings:



Note, information



Cleaning, care



Lubrication

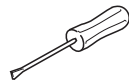

Maintenance, repairs, adjustment, service work  
(only to be carried out by technical staff)

## 7 Controls

### 7.01 On/off switch on machines with mini-stop motor without edge trimmer -725/.. or -726/..

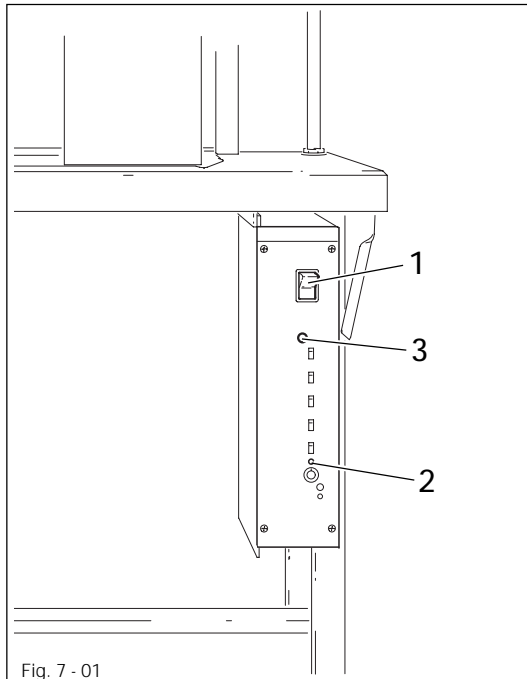

- The machine is switched on or off by pressing the on/off switch 1.
- The illuminated diode 2 controls the machine operation

#### Switch 1 on:

- |               |                               |
|---------------|-------------------------------|
| Diode on      | = Machine ready for operation |
| Diode flashes | = Fault                       |

#### Switch 1 off:

- |               |   |
|---------------|---|
| Diode flashes | = Machine still under electric current for about 4 sec. |
| Diode out     | = Machine off   |

- The machine speed can be adjusted on potentiometer 3.

### 7.02 On/off switch on machines with mini-stop motor and edge trimmer -725/.. oder -726/..

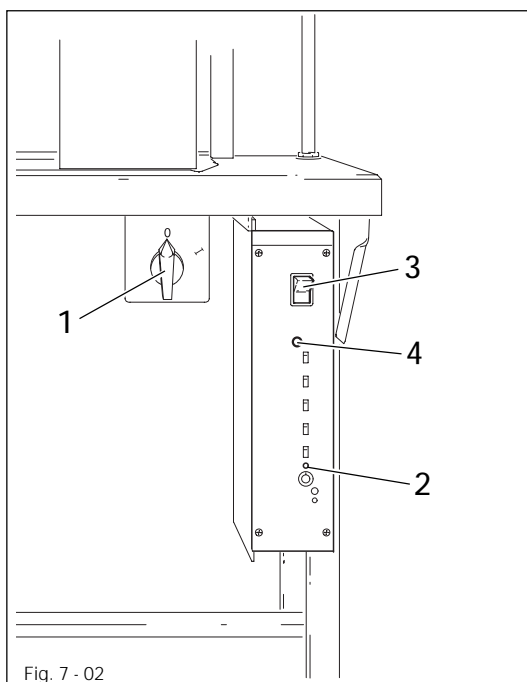

- The machine is switched on or off by turning the on/off switch 1.
- The illuminated diode 2 controls the machine operation

#### Switch 3 on:

- |               |                               |
|---------------|-------------------------------|
| Diode on      | = Machine ready for operation |
| Diode flashes | = Fault                       |

#### Switch 3 off:

- |               |   |
|---------------|---|
| Diode flashes | = Machine still under electric current for about 4 sec. |
| Diode out     | = Machine off   |

- The machine speed can be adjusted on potentiometer 4.



7.03 Button on machine head (only on machines with -911/..)

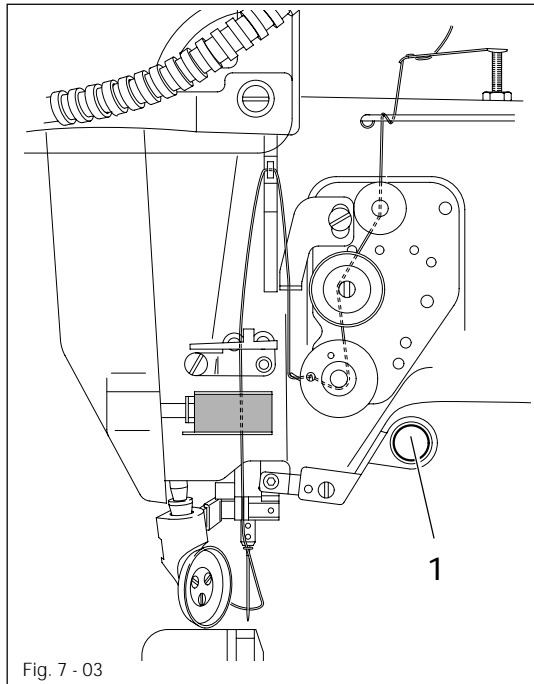

- If button 1 is operated during sewing, the machine switches to reverse sewing.

7.04 Pedal

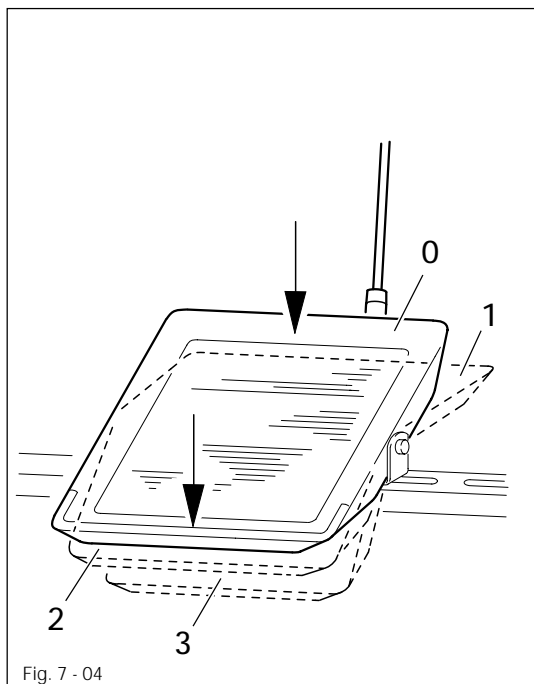

- 0 = Neutral position
- 1 = Sewing
- 2 = Raise roller presser (on machines with -910/..)
- 3 = Trim sewing threads (on machines with -900/..)

## 7.05 Lever for lifting roller presser

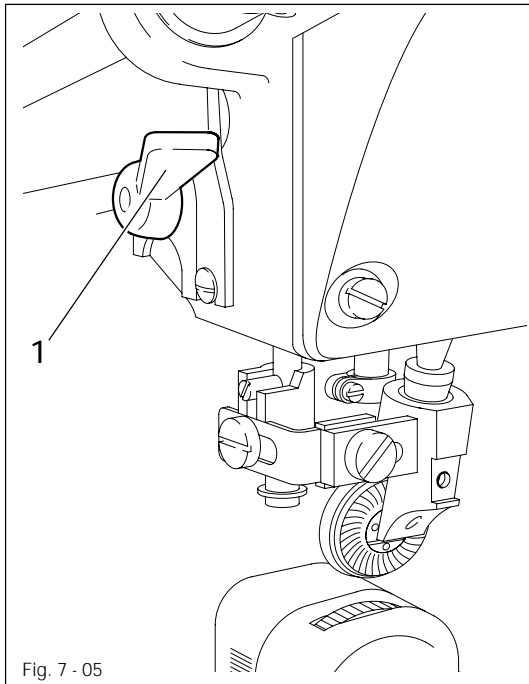

- The roller presser can be raised by turning lever 1.

## 7.06 Knee lever

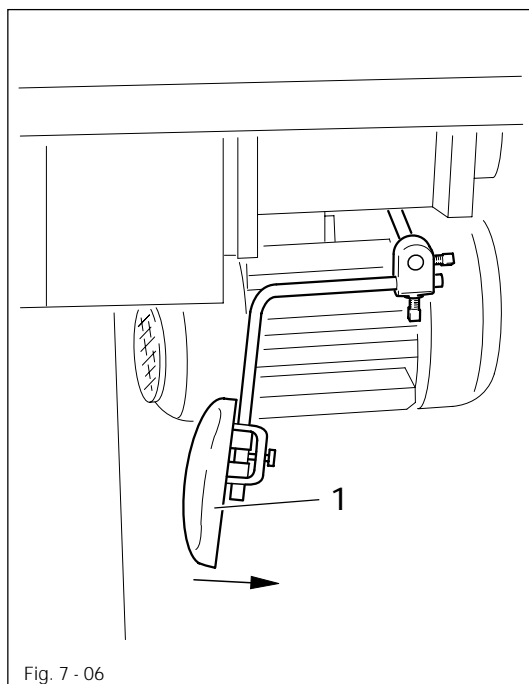

- The roller presser can be raised by pressing the knee lever 1 in the direction of the arrow.

7.07 Key for setting stitch length

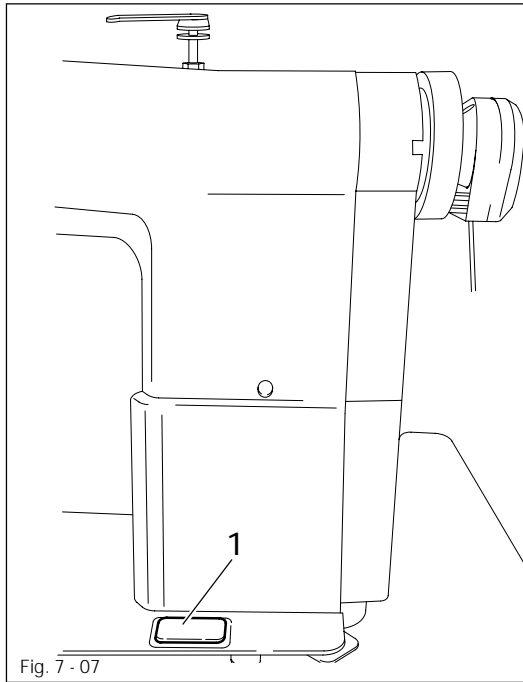

- The stitch length is set by pressing key 1 and turning the balance wheel (see Chapter 9.08 Setting the stitch length).

7.08 Swing out roller presser

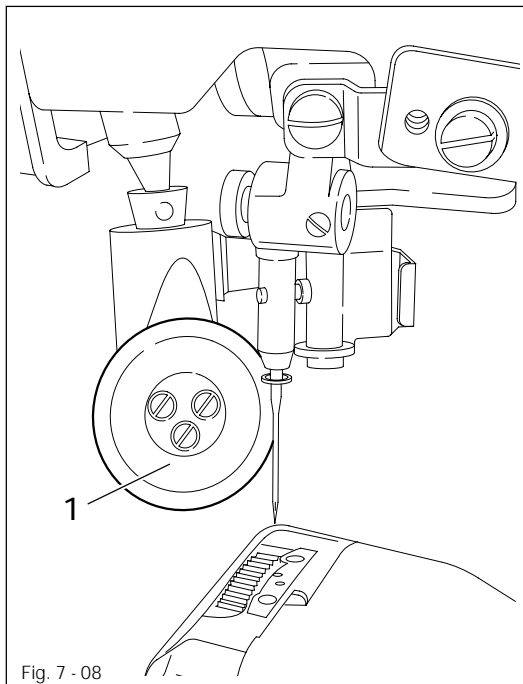

- When the roller presser is raised, it can be swung out by pulling it lightly downwards.

7.09

## Edge trimmer -725/04 for 471

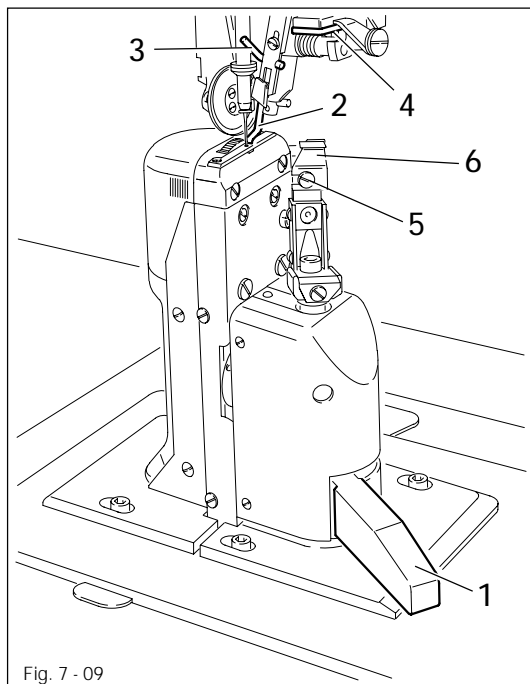

Keep your hands away from the moving knife! Danger of injury!

### Switch on knife drive:

- Move lever 1 backwards. The knife moves into operating position.

### Switch off knife drive:

- Press lever 1. The knife swings backwards.

### Switch on edge guide:

- Swing edge guide 2 into position by hand and press lever 3. The edge guide 2 moves into its operating position.

### Switch off edge guide:

- Raise edge guide 2 and let it click into position. The edge guide 2 is out of operation.
- Raise lever 4. The edge guide swings backwards.

### Changing the knife:



The following work may only be carried out by technical staff or by persons who have been properly instructed.

- Switch off the machine.
- Loosen screw 5 and remove knife 6.
- Insert new knife and slightly tighten screw 5.
- Adjust the knife according to Chapter 11.05.05 Cutting stroke and tighten screw 5.

7.10 Edge trimmer -725/04 for 474 and 491

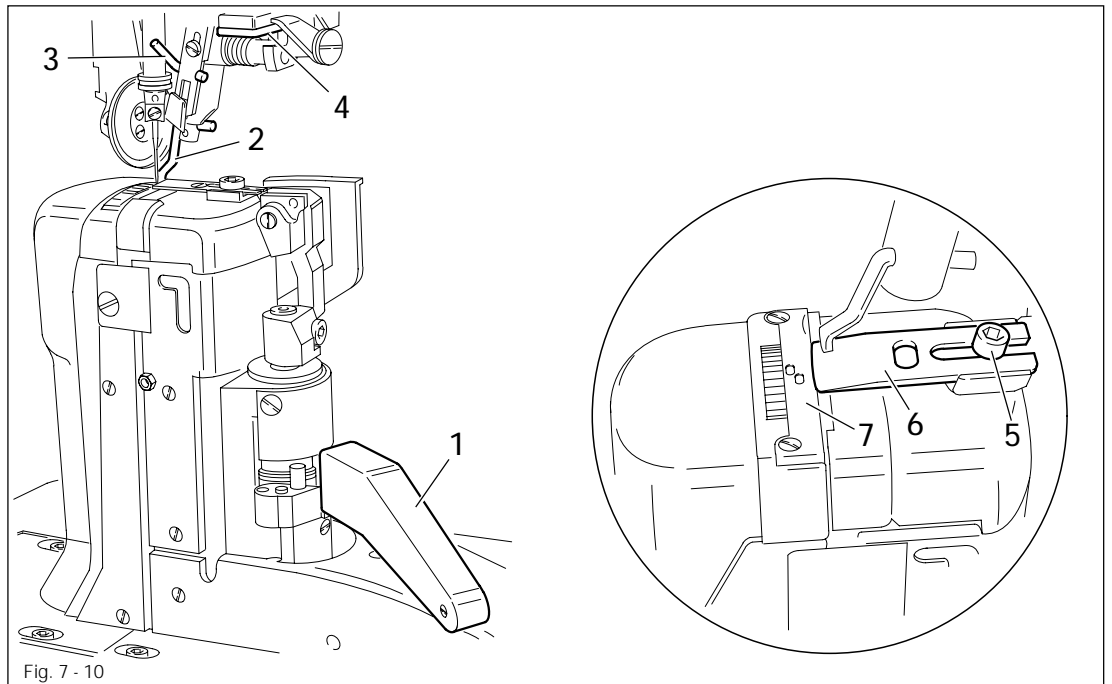

Keep your hands away from the moving knife! Danger of injury!

Switch on knife drive:

- Move lever 1 backwards. The knife moves into operating position.

Switch off knife drive:

- Press lever 1. The knife swings backwards.

Switch on edge guide:

- Swing edge guide 2 into position by hand and press lever 3. The edge guide 2 moves into its operating position.

Switch off edge guide:

- Raise edge guide 2 and let it click into position. The edge guide 2 is out of operation.
- Raise lever 4. The edge guide swings backwards.

Changing the knife:



The following work may only be carried out by technical staff or by persons who have been properly instructed.

- Switch off the machine.
- Loosen screw 5 and remove knife 6.
- Insert new knife and push it close to needle plate insert 7.
- Slightly tighten screw 5.
- Adjust the knife according to Chapter 11.05.07 Knife position and tighten screw 5.

## 7.11 Edge trimmer -726/05 for 491

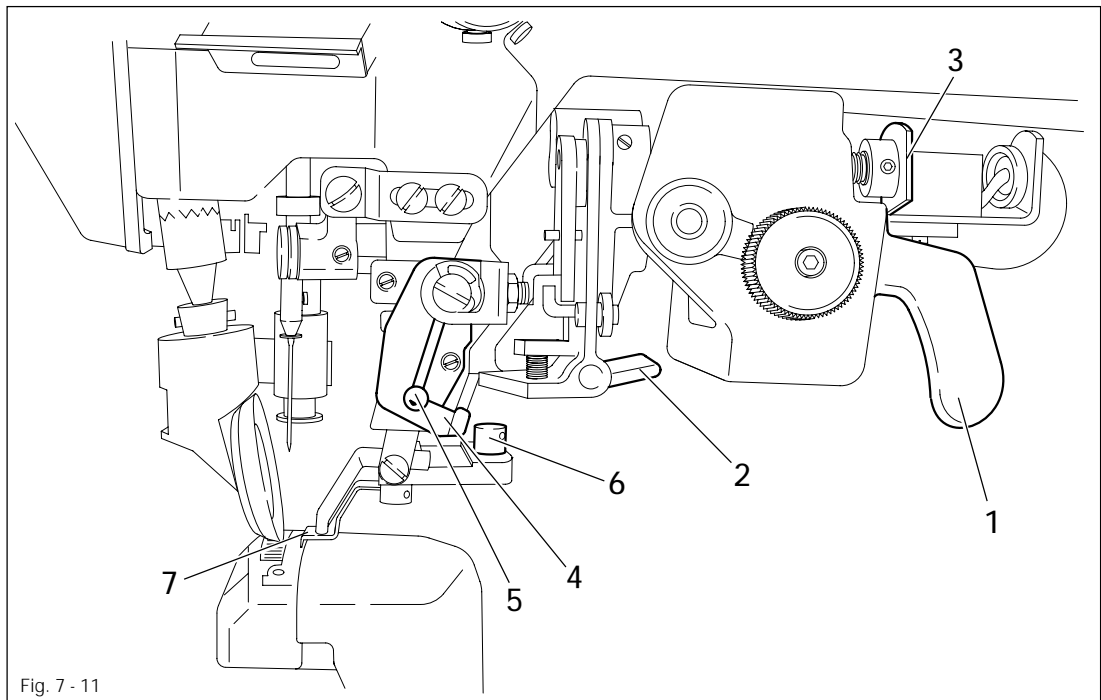

Keep your hands away from the moving knife! Danger of injury!

### Switch on knife drive:

- By turning lever 1 the knife is moved into its operating position.

### Switch off knife drive:

- By pressing lever 2 or key 3 the knife is put out of operation.

### Switch on edge guide:

- After lever 4 has been pressed, the edge guide moves into its starting position.

### Switch off edge guide:

- By raising lever 5, the edge guide is put out of operation.

### Changing the knife:



The following work may only be carried out by technical staff or by persons who have been properly instructed.

- Switch off the machine.
- Loosen screw 6 and remove knife 7.
- Insert new knife and push it close to needle plate insert.
- Tighten screw 6.
- Adjust the knife according to Chapter 11.06.01 Position of the knife to the needle plate and Chapter 11.06.02 Knife crosswise to sewing direction.

## 8 Installation and commissioning



The machine must only be installed and commissioned by qualified personnel!  
All relevant safety regulations must be strictly adhered to!



If the machine is delivered without a table, be sure to use a stand and table top that can hold the weight of the machine with its motor.  
It is very important to ensure that the stand of the machine is firm and steady, also during sewing.

### 8.01 Installation

The site where the machine is installed must be provided with suitable connections for electric current.

It must be ensured that the standing surface of the machine site is firm and horizontal, and that sufficient lighting is provided for.



For packing and transportation reasons the table top is in the lowered position.  
The table height is adjusted as described below.

#### 8.01.01 Adjusting the table height

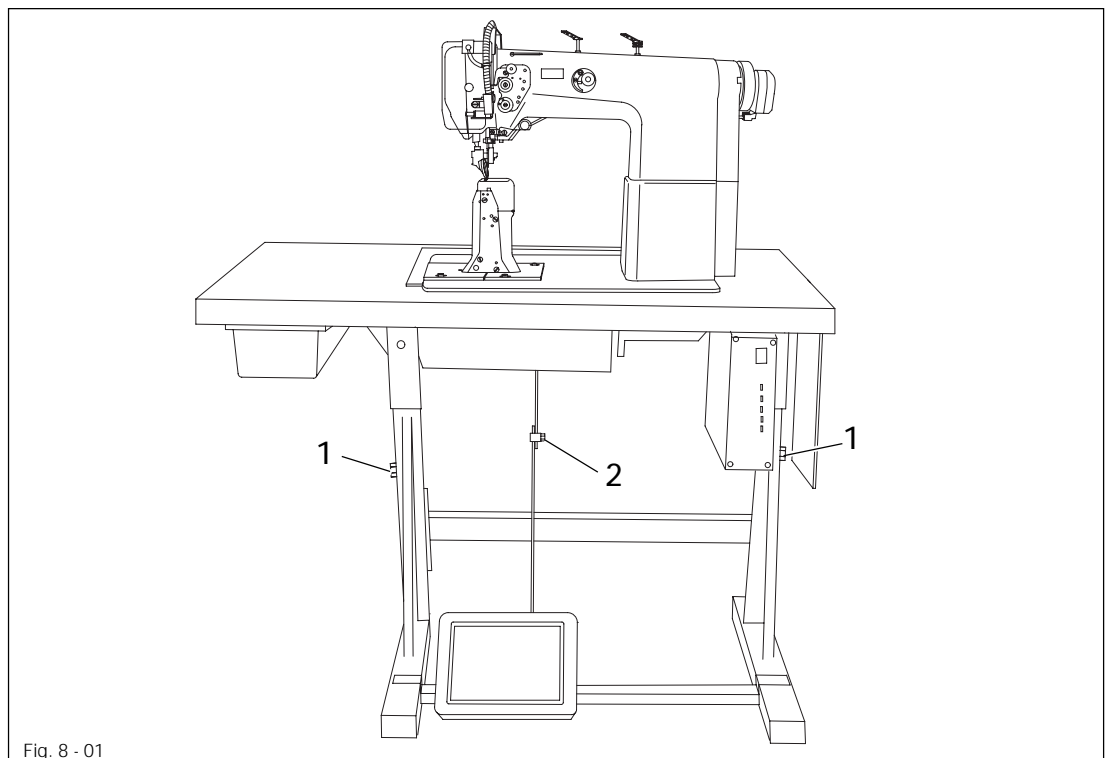
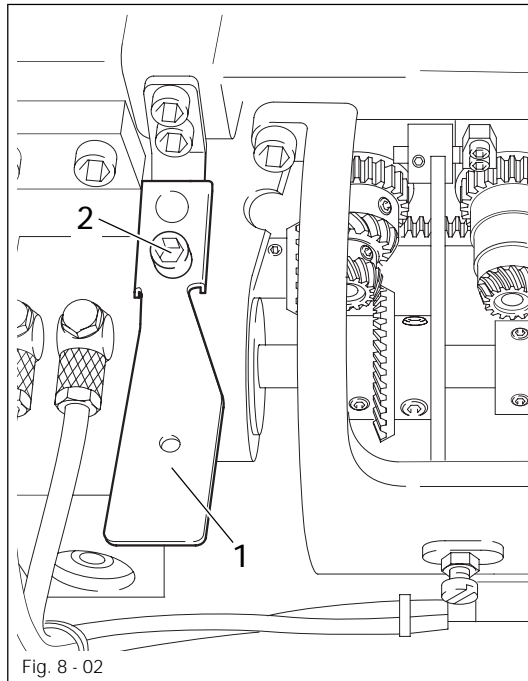

Fig. 8 - 01

- Loosen screws 1 and 2 and set the table height as required.
- Firmly tighten screw 1.
- Set the required pedal position and tighten screw 2.

# Installation and commissioning

## 8.01.02 Fitting the tilt lock



Switch off the machine!  
Danger of injury if the machine is started accidentally!

- Screw on the tilt lock 1, provided in the accessories, using screw 2.



Do not operate the machine without tilt lock 1. Danger of crushing between sewing head and table top!

## 8.01.03 Tensioning the v-belt (does not apply to machines with mini-stop motor)

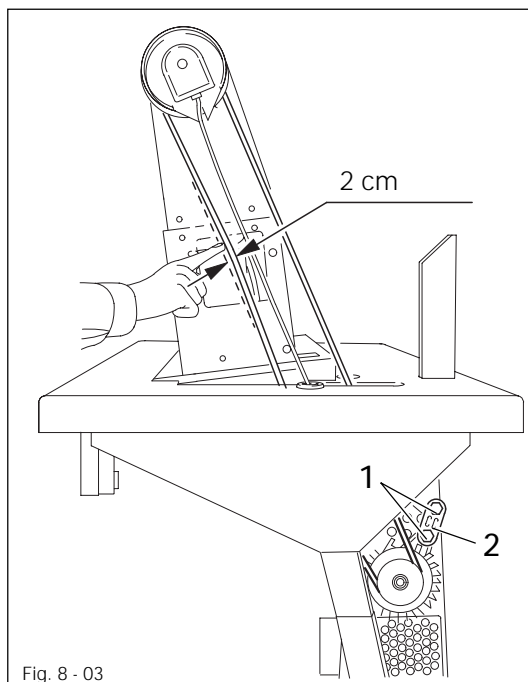

- Loosen the nuts 1.
- Set tension of v-belt using motor bracket 2.
- Tighten nuts 1.



## 8.01.04 Fitting the top v-belt guard

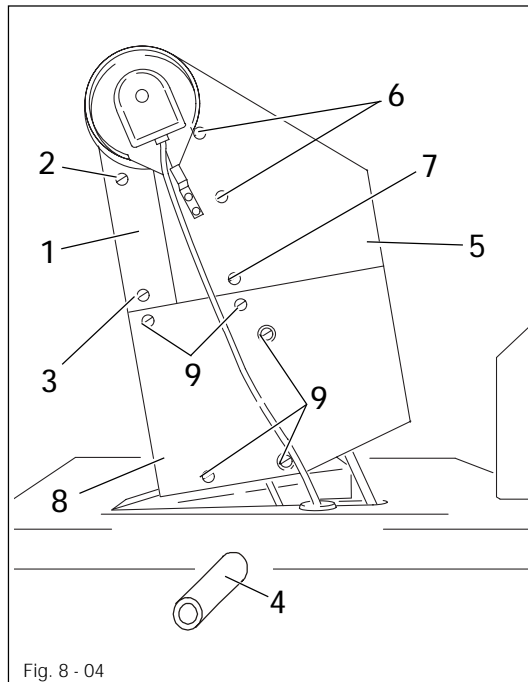

- Attach belt guard 1 with screws 2 and 3.
- Place spacing sleeve 4 between belt guard 1 and the machine housing.
- Attach belt guard 5 with screws 6 and 7.
- Place spacing sleeve 4 between belt guard 5 and the machine housing.
- Attach belt guard 8 with screws 9.

## 8.01.05 Fitting the bottom v-belt guard (does not apply to machines with mini-stop motor)

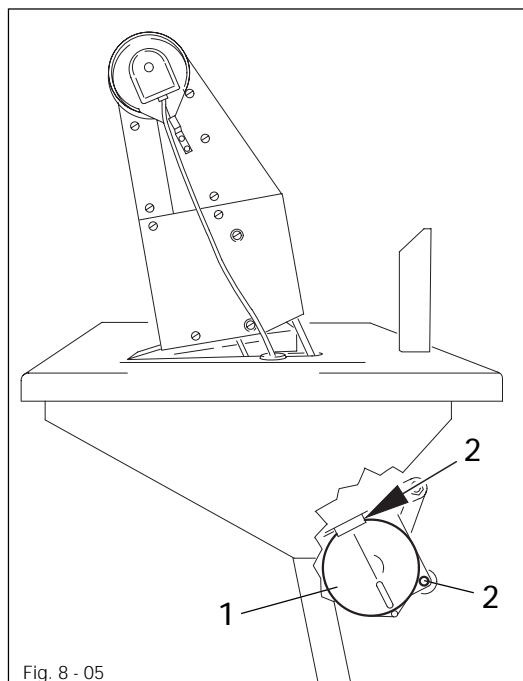

- Adjust the v-belt guard 1 so that the motor pulley and v-belt run freely.
- Tighten screws 2. Fig. 8-05 shows a Quick motor.



If another motor is used, the instruction manual of the motor must be complied with.

## Installation and commissioning

### 8.01.06 Fitting the synchronizer

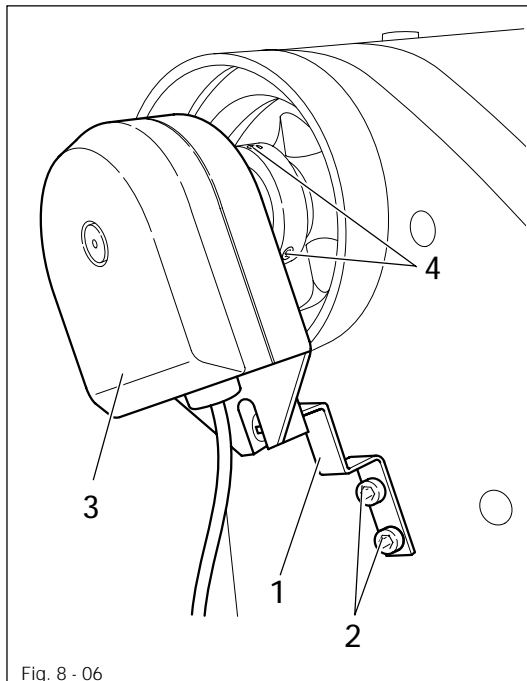

- Attach position stop 1 using screws 2.
- Push synchronizer 3 onto the shaft so that the position stop 1 is in the groove of the synchronizer (see arrow).
- Slightly tighten screws 4.
- Insert the synchronizer plug in the connection socket of the control box.
- Adjust the synchronizer 3 (see Chapter 11.04.01 Adjusting the Synchronizer).

### 8.01.07 Fitting the reel stand

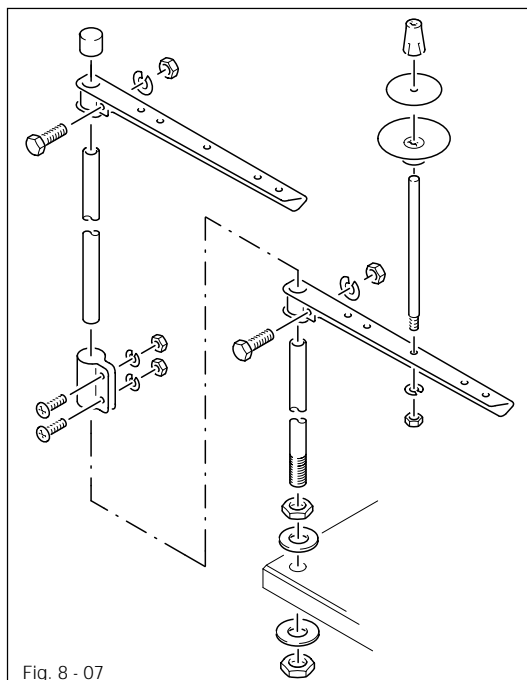

- Fit the reel stand as shown in Fig. 8-07.
- Afterwards insert the stand in the hole in the table top and secure it with the nuts provided.

### 8.02 Commissioning

- Check the machine, particularly the electrical wiring, for any damage.
- Clean the machine thoroughly and then oil it or fill in oil (see **Chapter 10 Care and maintenance**).
- Have a mechanic check whether the motor of the machine can be operated with the available power supply, and that the motor is correctly connected in the junction box. If there are any discrepancies the machine **must not be operated under any circumstances**.



The machine may only be connected to an earthed socket!

- When the machine is running, the balance wheel must turn towards the operator. If it does not, have the motor connection changed by a mechanic.
- Machines with pneumatic equipment must be connected to the compressed air supply. The pressure gauge should indicate a pressure of 6 bar. If necessary, adjust to the correct setting (see **Chapter 10.05 Checking adjusting the air pressure**).

### 8.03 Switching the machine on/off

- Switch the machine on or off (see **Chapter 7.01 On/off switch**).

## Setting up



All instructions and regulations in this instruction manual must be observed. Special attention must be paid to all safety regulations!



All setting-up work must only be carried out by personnel with the appropriate training. For all setting-up work the machine must be disconnected from its power supply by turning off the on/off switch, or removing the plug from the electric power socket.

### 9.01

#### Inserting the needle on model 471 and 491

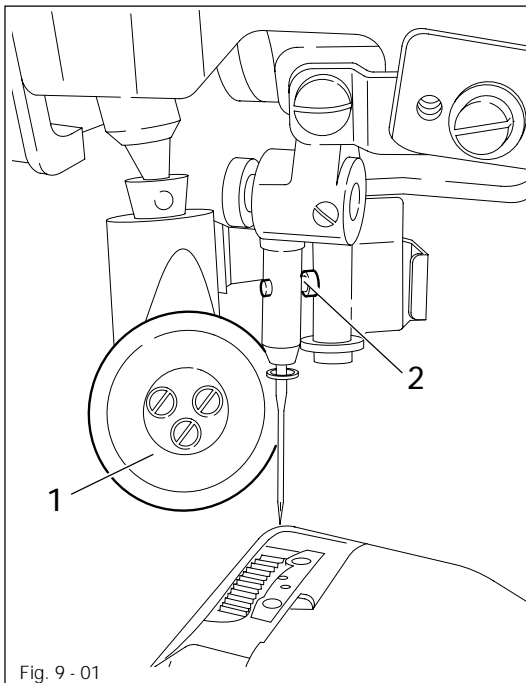

Switch the machine off!  
Danger of injury if the machine is started accidentally!

Only use needles of system 134.

- Raise the roller presser 1 and swing it out.
- Loosen screw 2 and insert the needle as far as possible. The long groove must face to the right on model 471 and to the left on model 491.
- Tighten screw 2 and swing roller presser 1 back into position.

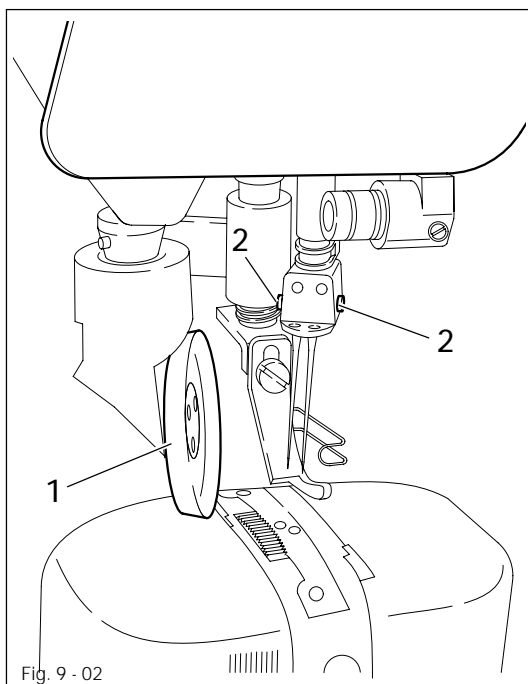

Fig. 9-01 shows model 491.



The choice of needle depends on the model of the machine and the thread and material used (see Chapter 3.02 Needles and threads).

9.02 Inserting the needle on model 474



Switch the machine off!  
 Danger of injury if the machine  
 is started accidentally!

Only use needles of system 134-35.

- Raise the roller presser 1 and swing it out.
- Loosen screws 2 and insert the needles so that the long groove of the left needle is facing right, and that of the right needle is facing left.
- Tighten screws 2 and swing roller presser 1 back into position.



The choice of needle depends on the model of the machine and the thread and material used (see Chapter 3.02 Needles and threads).

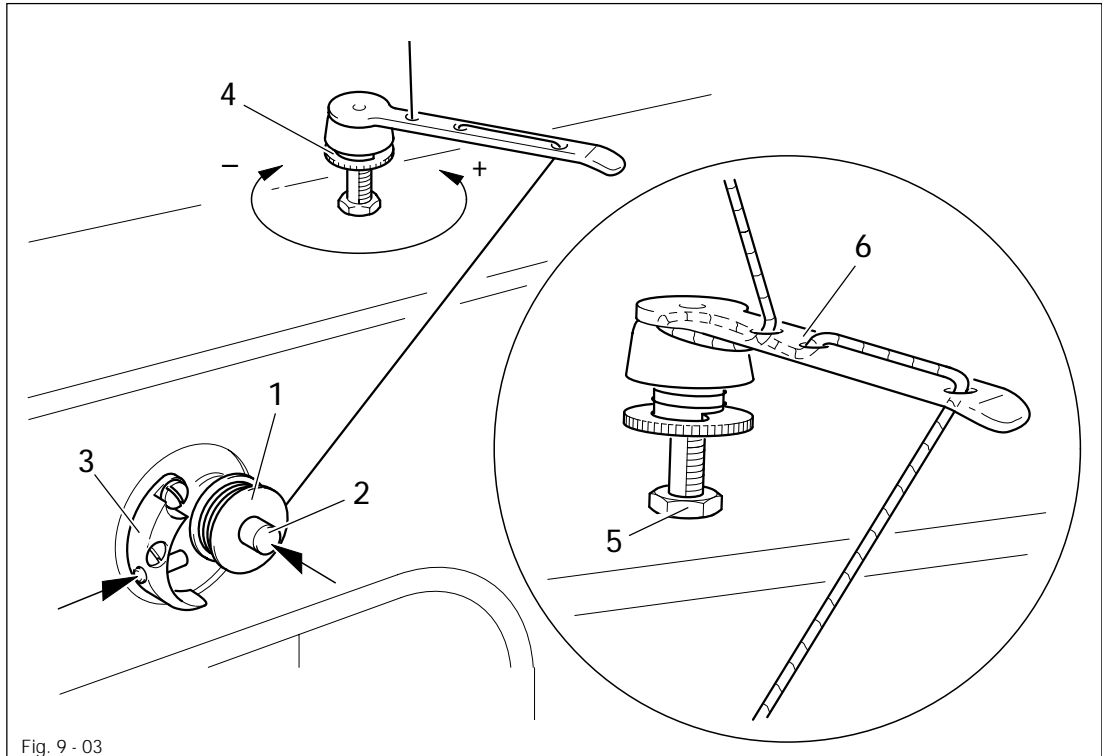

Fig. 9 - 03

- Place an empty bobbin 1 onto bobbin winder spindle 2.
- Thread the bobbin as shown in Fig. 9 - 03 and wind it clockwise around bobbin 1 a few times.
- Switch on the bobbin winder while at the same time pressing bobbin winder spindle 2 and lever 3.



The bobbin is filled up during sewing.

- The thread tension on bobbin 1 can be adjusted using knurled screw 4.
- The bobbin winder stops automatically when bobbin 1 is full.

If the thread is wound unevenly:

- Loosen nut 5.
- Turn thread guide 6 accordingly.
- Tighten nut 5.

9.04 Removing/Inserting the bobbin case

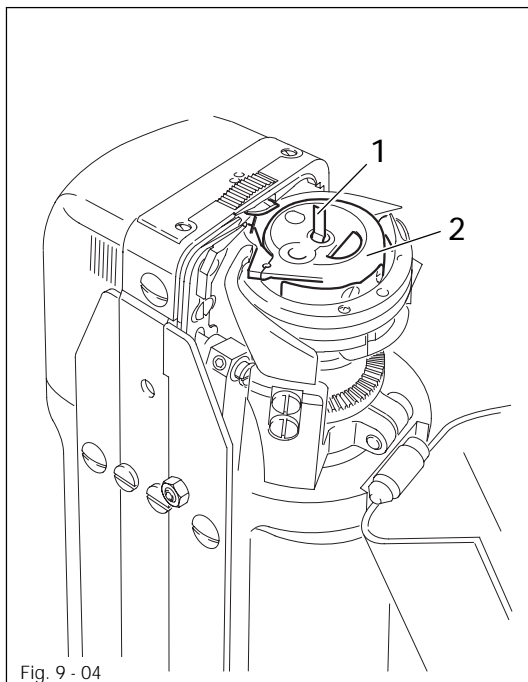

Fig. 9 - 04



Turn the machine off!

Removing the bobbin case:

- Open the post cap.
- Raise latch 1 and remove bobbin case 2.

Inserting the bobbin case:

- Insert bobbin case 2.
- Close the latch and close the post cap.



474 is shown in Fig. 9 - 04.

9.05 Threading the bobbin case/Adjusting the bobbin thread tension

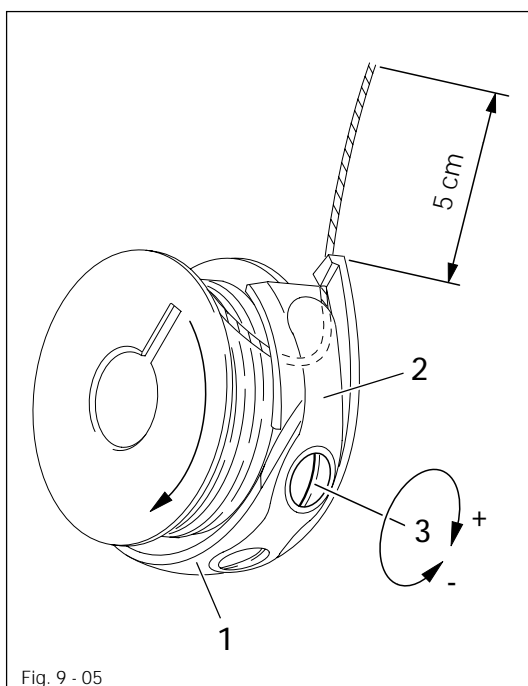

Fig. 9 - 05

- Insert the bobbin into the bobbin case 1.
- Pass the thread through the slot under spring 2.
- Pass the thread through the notch.
- Adjust the thread tension by turning screw 3.



When the thread is pulled, the bobbin must rotate in the direction of the arrow.

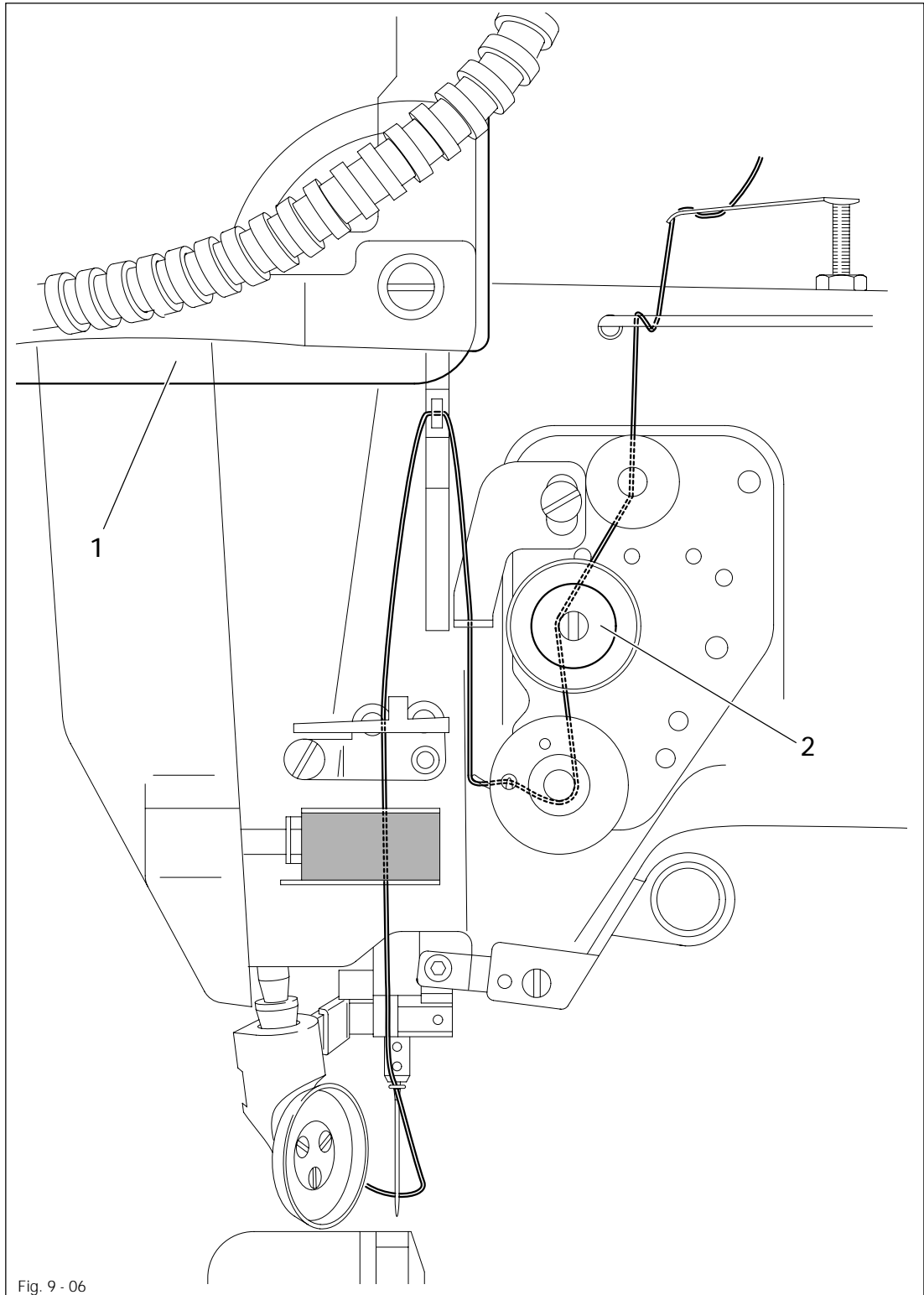

Fig. 9 - 06



Switch the machine off!

Danger of injury if the machine is started accidentally!

- Tilt up the eye guard 1.
- Thread the needle thread as shown in Fig. 9-06.
- On model 471 the needle is threaded from the right to the left, and on model 491 from the left to the right.
- Adjust the needle thread tension by turning milled screw 2.



9.07

Threading the needle thread and regulating its tension on model 474

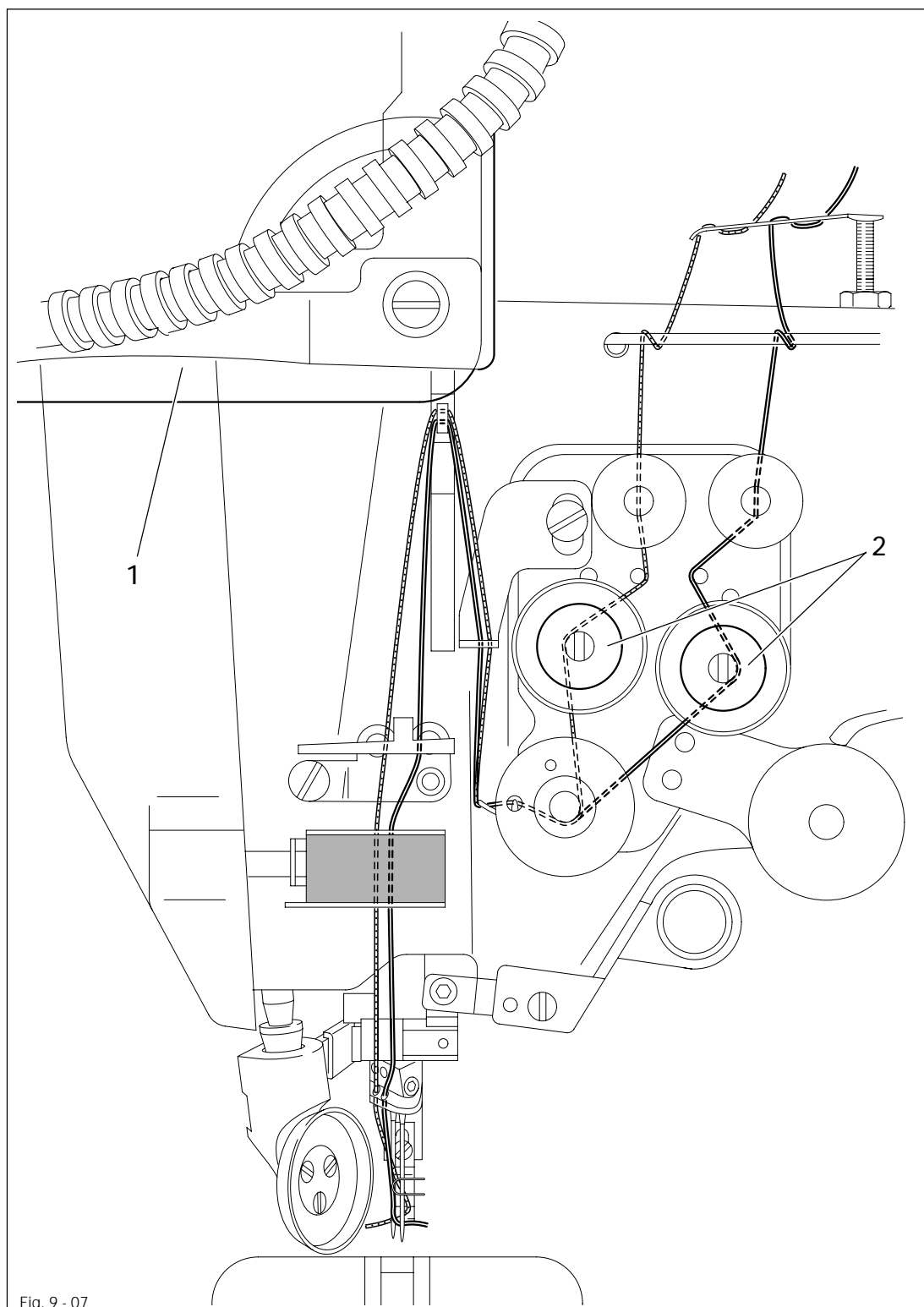

Fig. 9 - 07



Switch the machine off!  
 Danger of injury if the machine is started accidentally!

- Tilt up the eye guard 1.
- Thread both needle threads as shown in Fig. 9-07.
- The left needle is threaded from the right to the left, and the right needle from the left to the right.
- Adjust the needle thread tensions by turning milled screws 2.

## 9.08 Setting the stitch length

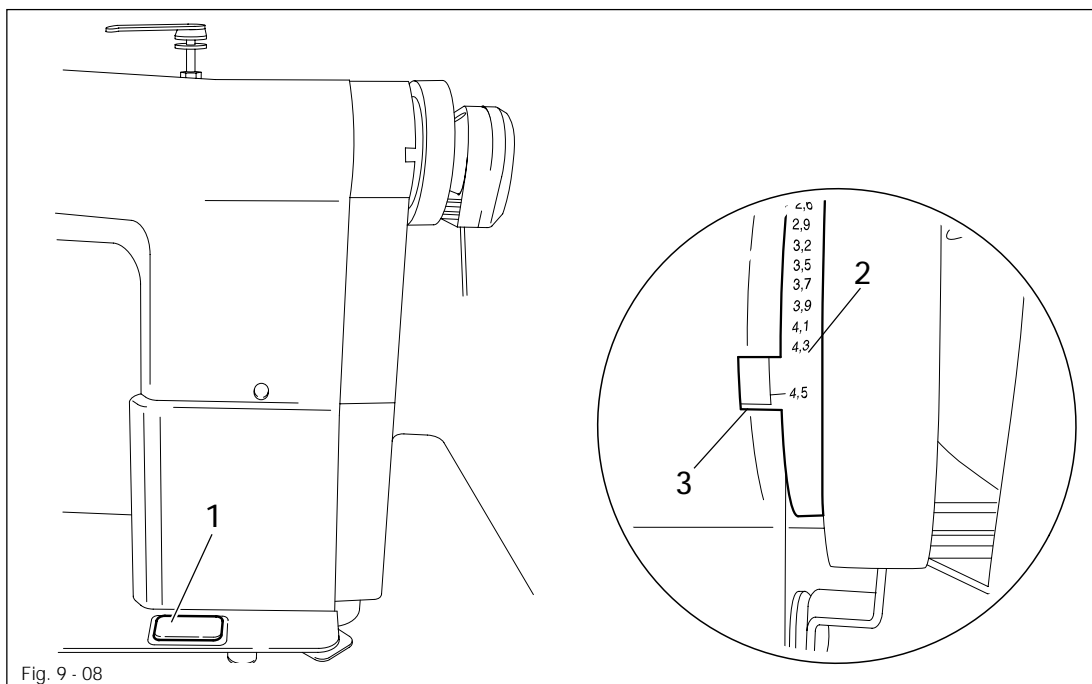

Fig. 9 - 08

- Press key 1 and at the same time turn the balance wheel until the stitch setter clicks into position.
- Hold down key 1 and turn the balance wheel to and fro until the stitch length required is shown on the scale 2 opposite the bottom edge 3 of the belt guard recess.

10 Care and maintenance

Clean .....	daily, more frequently if in continuous operation
Oil level (thread lubrication) .....	daily, before operation
Oil the hook .....	daily, before operation
Lubricate the bevel gears .....	once a year
Check/adjust air pressure .....	daily, before operation
Clean air filter of air-filter/lubricator .....	when required



These maintenance intervals are calculated for the average running time of a single shift operation. If the machine is operated more than this, shorter intervals are recommended.

10.01 Cleaning

Clean the hook and hook compartment daily, more often if in continuous operation.

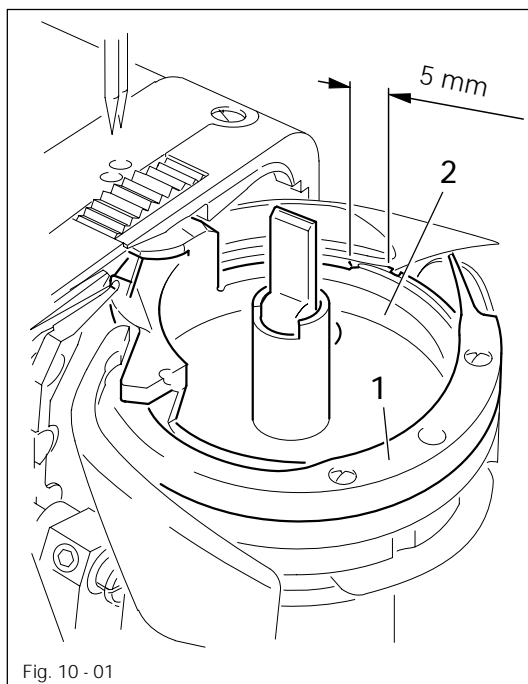

Switch the machine off!  
Danger of injury if the machine is started accidentally!

- Bring the needle bar to its highest position.
- Open the post cap and remove the bobbin case cap and the bobbin.
- Unscrew hook gib 1.
- Turn the handwheel until the point of bobbin case 2 penetrates into the groove of the hook race approx. 5 mm.
- Remove bobbin case 2.
- Clean the hook race with paraffin.
- When inserting the bobbin case 2, ensure that the horn of the bobbin case 2 engages in the groove of the needle plate.
- Screw hook gib 1 back on and close the post cap.

## 10.02 Oiling the hook

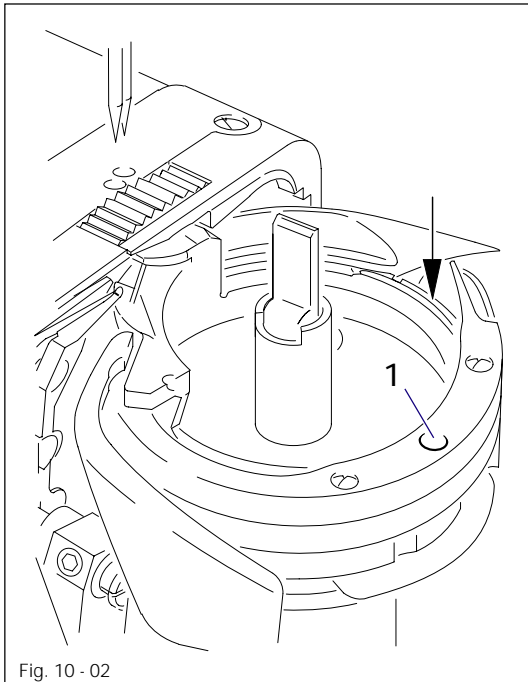

Switch the machine off!  
Danger of injury if the machine is started accidentally!

- Pour 1-2 drops of oil into hole 1 of the hook gib daily.
- Before commissioning the machine, and after long periods out of operation, pour a few drops of oil into the hook race (see arrow).

## 10.03 Filling the oil reservoir of the thread lubrication unit

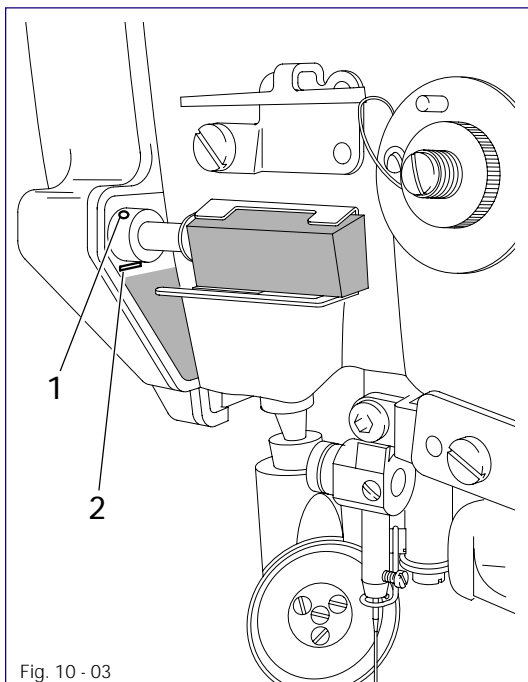

Control the oil level before each use.

There must always be oil in the reservoir.

- If necessary, fill oil up to mark 2 through hole 1.

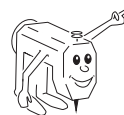

We recommend  
PFAFF thread lubricating oil,  
Order No. 280-1-120217.

10.04 Lubricating the bevel gears

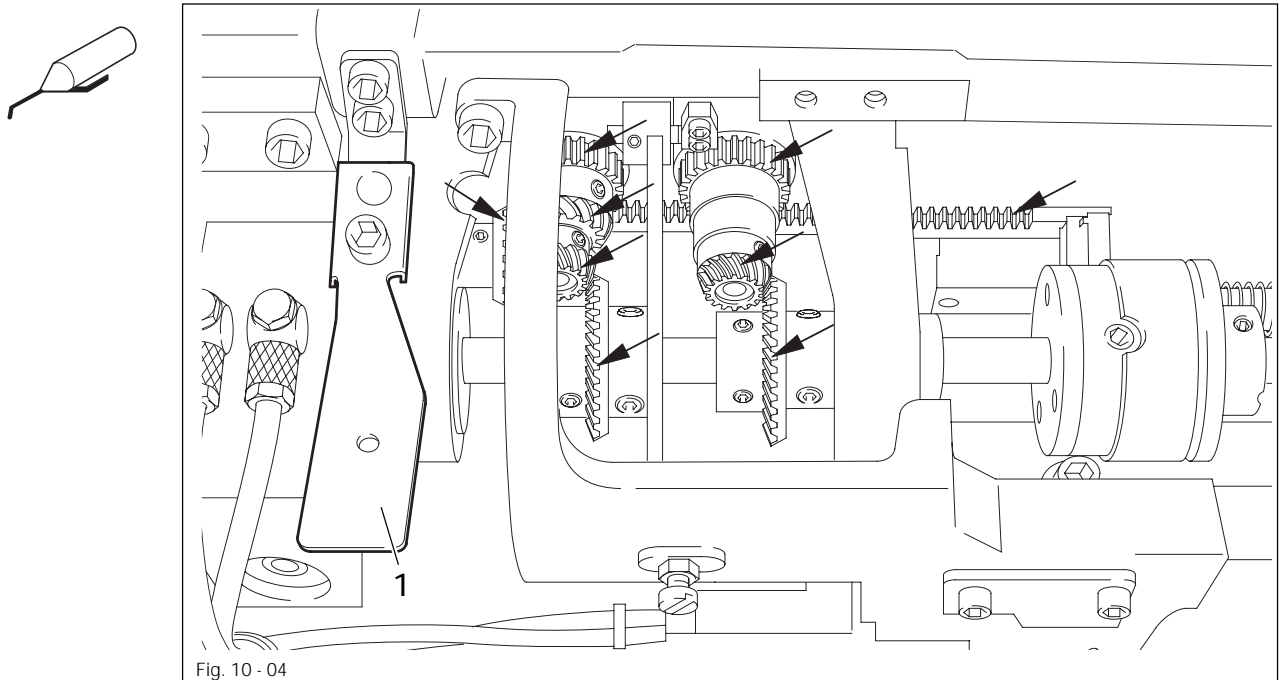

Fig. 10 - 04



Switch the machine off!  
Danger of injury if the machine is started accidentally!

- Once a year new grease must be applied to the bevel gears, which drive the hook and the toothed rack.
- Tilt the sewing head back onto the support.

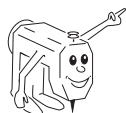

Fig. 10-04 shows the bevel gears of the 474.

- Apply grease to all the tooth flanks and the rack (see arrows).
- To set the sewing head upright, press tilt lock 1 backwards and set the sewing head upright using both hands.



Use both hands to set the sewing head upright!  
Danger of crushing between the sewing head and the table top!



We recommend PFAFF sodium grease with a dripping point of approx. 150C,  
Order No. 280-1-120 243.

### 10.03 Checking/adjusting the air pressure

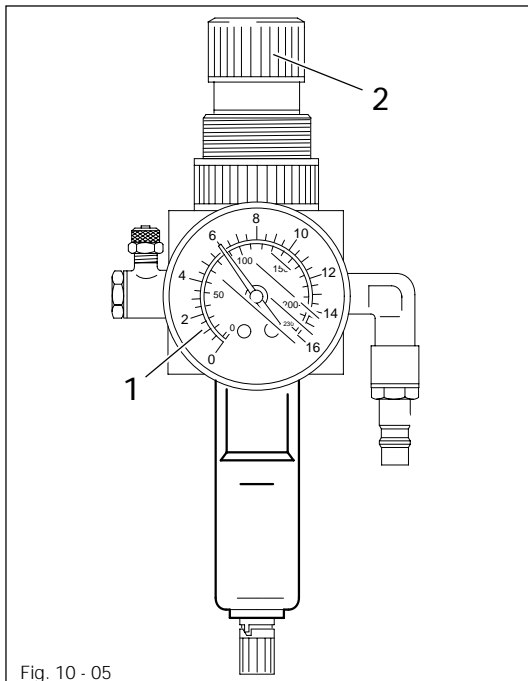

Fig. 10 - 05

- Before operating the machine, always check the air pressure on gauge 1.
- Gauge 1 must show a pressure of 6 bar.
- If necessary adjust to this reading.
- To do so, pull knob 2 upwards and turn it so that the gauge shows a pressure of 6 bar.

### 10.04 Cleaning the air filter of the air-filter/lubricator

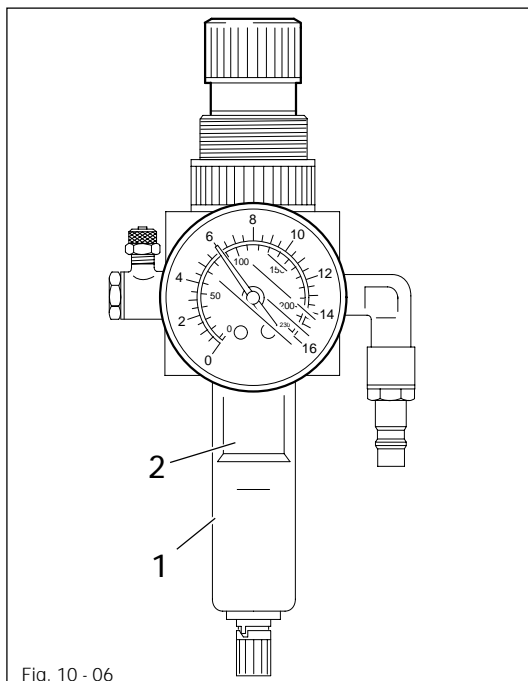

Fig. 10 - 06



Switch the machine off!  
Disconnect the air hose at the  
air-filter/lubricator.

To drain water bowl 1:

- Water bowl 1 drains itself automatically when the compressed-air hose is disconnected from the air-filter/lubricator.

Cleaning filter 2:

- Unscrew water bowl 1.
- Take out filter 2.
- Clean filter 2 with compressed air or isopropyl alcohol (part No. 95-665 735-91).
- Screw in filter 2 and screw on water bowl 1.

## 11 Adjustment

### 11.01 Notes on adjustment

All adjustments in these adjustment instructions are based on a completely installed machine and must only be carried out by appropriately trained specialists. Covers on the machine, which have to be removed and replaced for checks and adjustment work, are not mentioned here.

The screws and nuts in brackets ( ) are attachments of machine parts which are to be loosened before making the adjustment and tightened again after the adjustment has been carried out.



The machine must be switched off for all adjustment work!  
Danger of injury if the machine is started accidentally!

### 11.02 Tools, gauges and other accessories

- 1 set of screwdrivers with blade widths from 2 to 10 mm
- 1 set of open-ended wrenches with opening sizes from 7 to 13 mm
- 1 set of allen keys from 1.5 to 6 mm
- 1 clamp (Order No. 08-880 137-00)
- 1 metal rule (Order No. 08-880 218-00)
- 1 gauge (Order No. 08-880 136-01)
- Sewing thread and test material

### 11.03 Abbreviations

TDC = top dead center

BDC = bottom dead center

## 11.04 Adjusting the basic machine

### 11.04.01 Adjusting the synchronizer

#### Requirements

1. When sewing is interrupted, the machine must be in a position 5 mm before BDC of the needle bar.
2. After thread trimming the machine must be in the position TDC of the take-up lever.

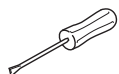
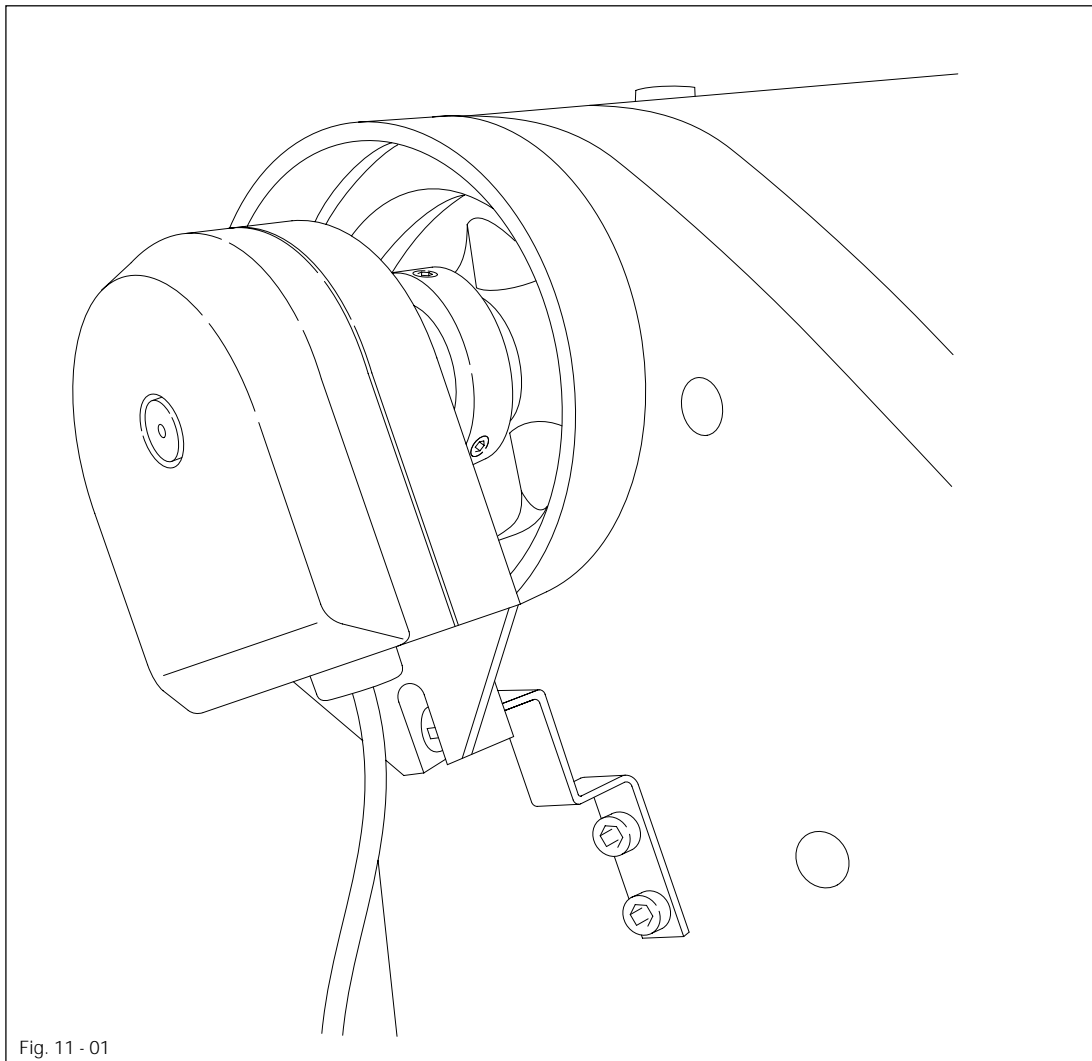

- Carry out adjustments according to the motor instruction manual.
- See also Chapter 11.10 Parameter settings.



## 11.04.02 Needle position in sewing direction on the PFAFF 471 and 491

### Requirement

With the stitch length set at its minimum, the needle should be positioned in the centre of the needle hole, as seen in the direction of sewing.

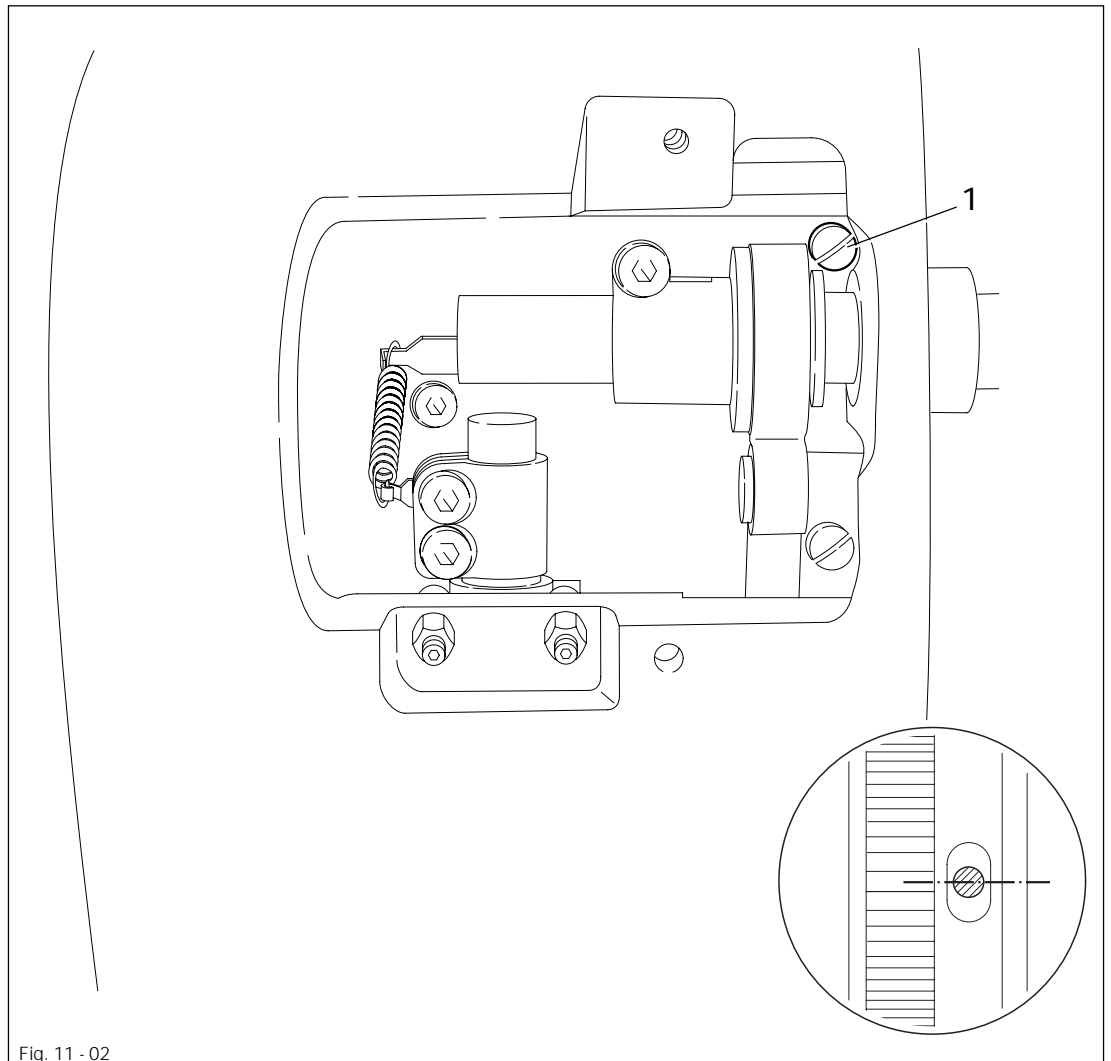
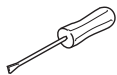

Fig. 11 - 02



- Set the minimum stitch length.
- Adjust needle bar (screw 1) according to the requirement.

# Adjustment

## 11.04.03 Needle position in sewing direction on the PFAFF 474

### Requirement

The needle should be positioned in the centre of the needle hole as seen in the direction of sewing.

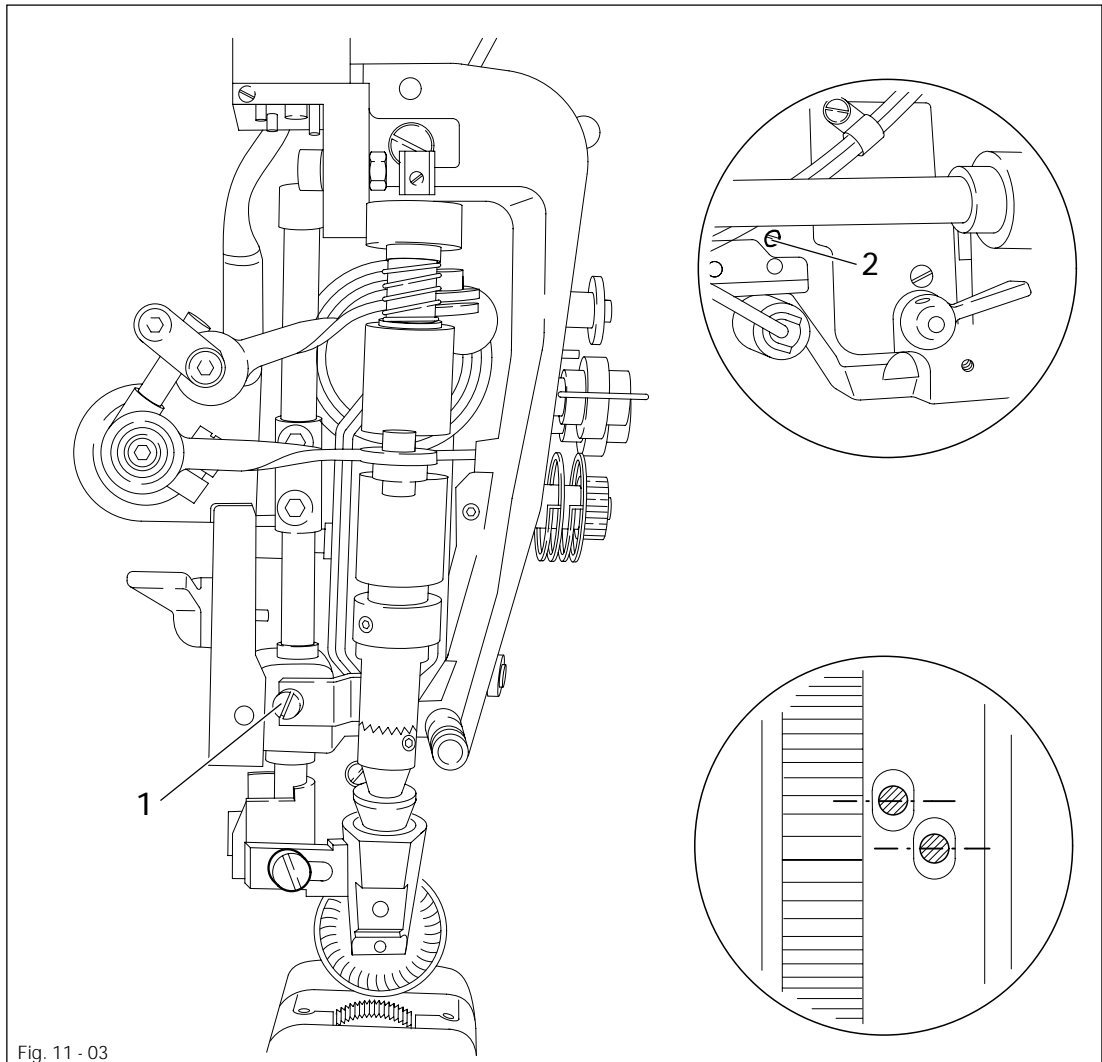
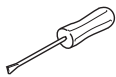

Fig. 11 - 03



- Adjust needle bar (screws 1 and 2) according to the requirement.



Screw 2 is accessible through a hole on the rear side of the case.

## 11.04.04 Preliminary adjustment of the needle height

### Requirement

When the needle bar is at TDC, there must be a clearance of approx. 22 mm between the needle point and the needle plate.

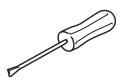
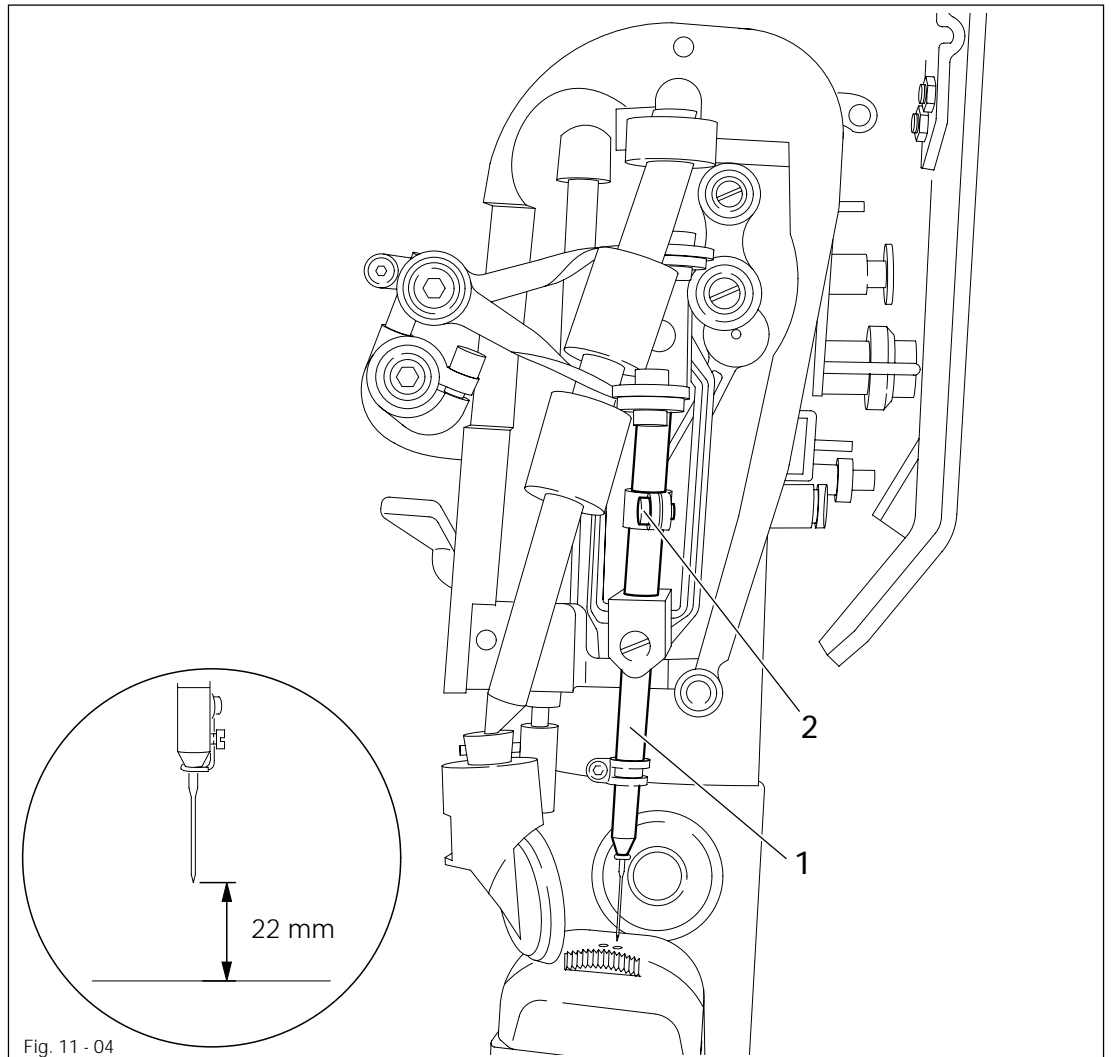

- Adjust needle bar 1 (screw 2), without turning it, according to the requirement.

## 11.04.05 Needle rise, hook clearance, needle height and needle guard on the PFAFF 471

### Requirement

With the needle bar positioned 1.8 mm after BDC and the stitch length set at "0.8"

1. the hook point must be at needle centre with a hook-to-needle clearance of **0.05 to 0.1 mm**;
2. the top of the needle eye must be **0.8 to 1.0 mm** below the hook point;
3. the needle guard **6** must touch the needle lightly.

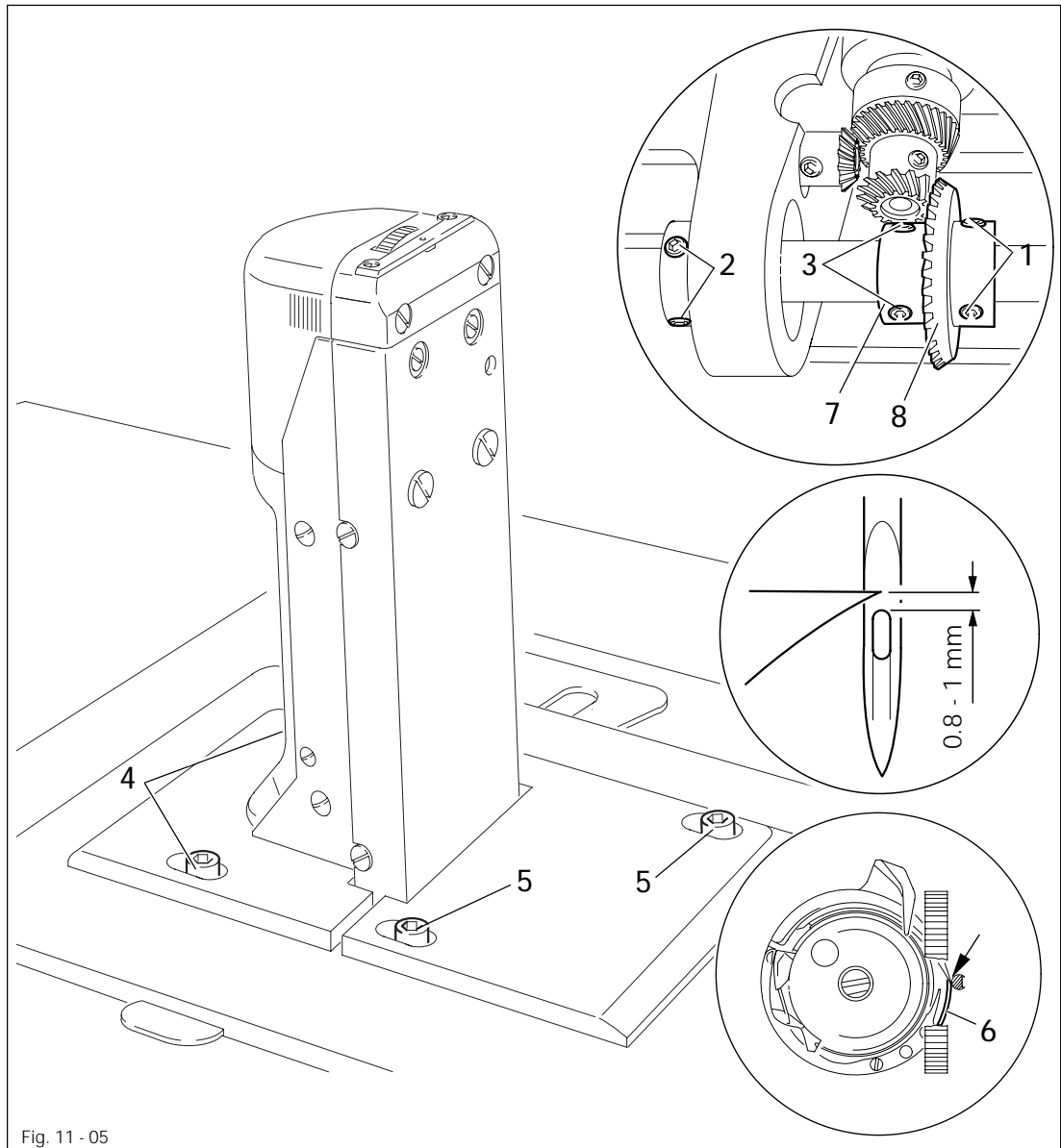
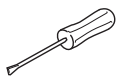

Fig. 11 - 05



- Set stitch length at "0.8".
- Loosen both screws **1, 2, 3, 4** and **5**.
- Bring needle bar to 1.8 mm past BDC:
- Set hook point at needle centre, making sure that the needle is not deflected by needle guard **6**.
- Adjust needle height according to **Requirement 2**.
- Adjust hook post according to **Requirement 1** and tighten screws **4** and **5**.

- Making sure that there is some play in the bevel gear, tighten screws 1.
- With retaining collar 7 touching bevel gear 8 tighten screws 2 and 3.
- Adjust needle guard 6 according to **Requirement 3**.



When the hook is replaced, care must be taken to see that markings 9 and 10 are on the same side.

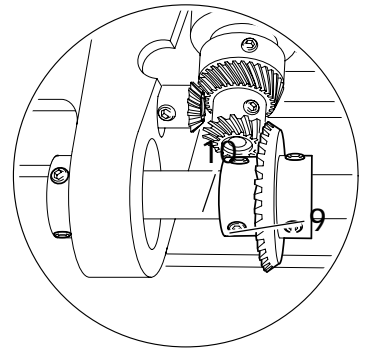

## 11.04.06 Needle rise, hook clearance, needle height and needle guard on the PFAFF 474

### Requirement

With the needle bar positioned 1.8 mm after BDC on both hooks

1. the hook point must be at needle centre with a hook-to-needle clearance of 0.05 to 0.1 mm;
2. the top of the needle eye must be 0.8 to 1.0 mm below the hook points;
3. the needle guard 9 must touch the needle lightly.

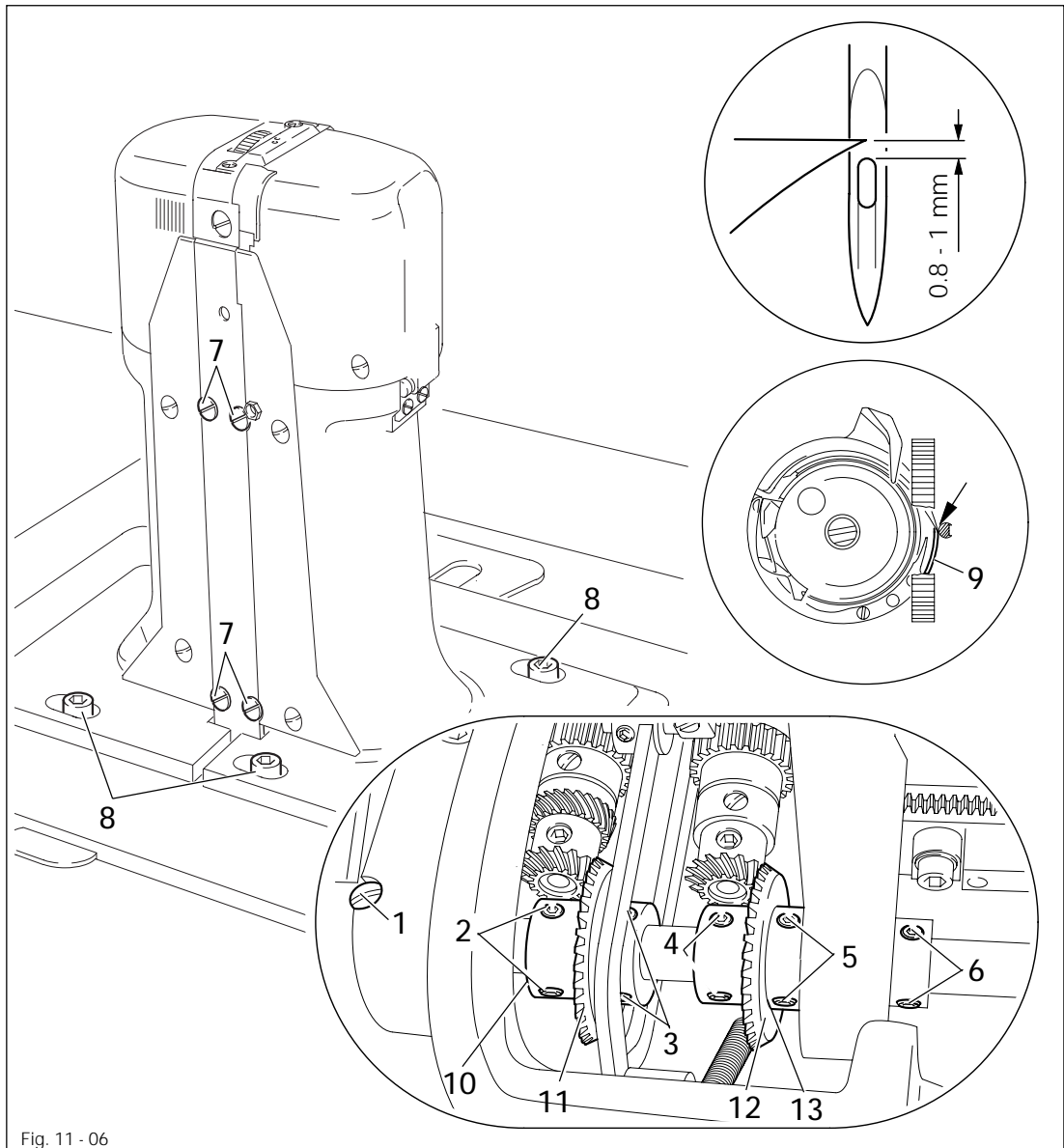
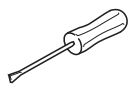

Fig. 11 - 06



- Loosen screws 1, 2, 3, 4, 5, 6 and 7.
- Loosen screws 8 slightly.
- Bring needle bar to 1.8 mm past BDC:
- Set both hook points at needle centre, making sure that the needles are not deflected by needle guard 9.
- Adjust needle height according to Requirement 2.
- Adjust both hook posts according to Requirement 1 and tighten screws 8.

- Tighten screws 1 and 6.
- Making sure that there is some play in the bevel gear, tighten screws 3 and 5.
- With retaining collar 10 touching bevel gear 11 tighten screws 2.
- With retaining collar 12 touching bevel gear 13 tighten screws 4.
- Tighten screws 7 on both sides of the post.
- Adjust needle guard 9 on both hooks according to Requirement 3.



When the hook is replaced, care must be taken to see that markings 14 and 15 are on the same side.

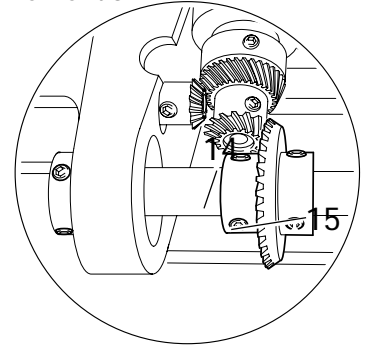

## 11.04.07 Needle rise, hook clearance, needle height and needle guard on the PFAFF 491

### Requirement

With the needle bar positioned 1.8 mm after BDC and the stitch length set at "0.8"

1. the hook point must be at needle centre with a hook-to-needle clearance of **0.05 to 0.1 mm**;
2. the top of the needle eye must be **0.8 to 1.0 mm** below the hook point;
3. the needle guard **6** must touch the needle lightly.

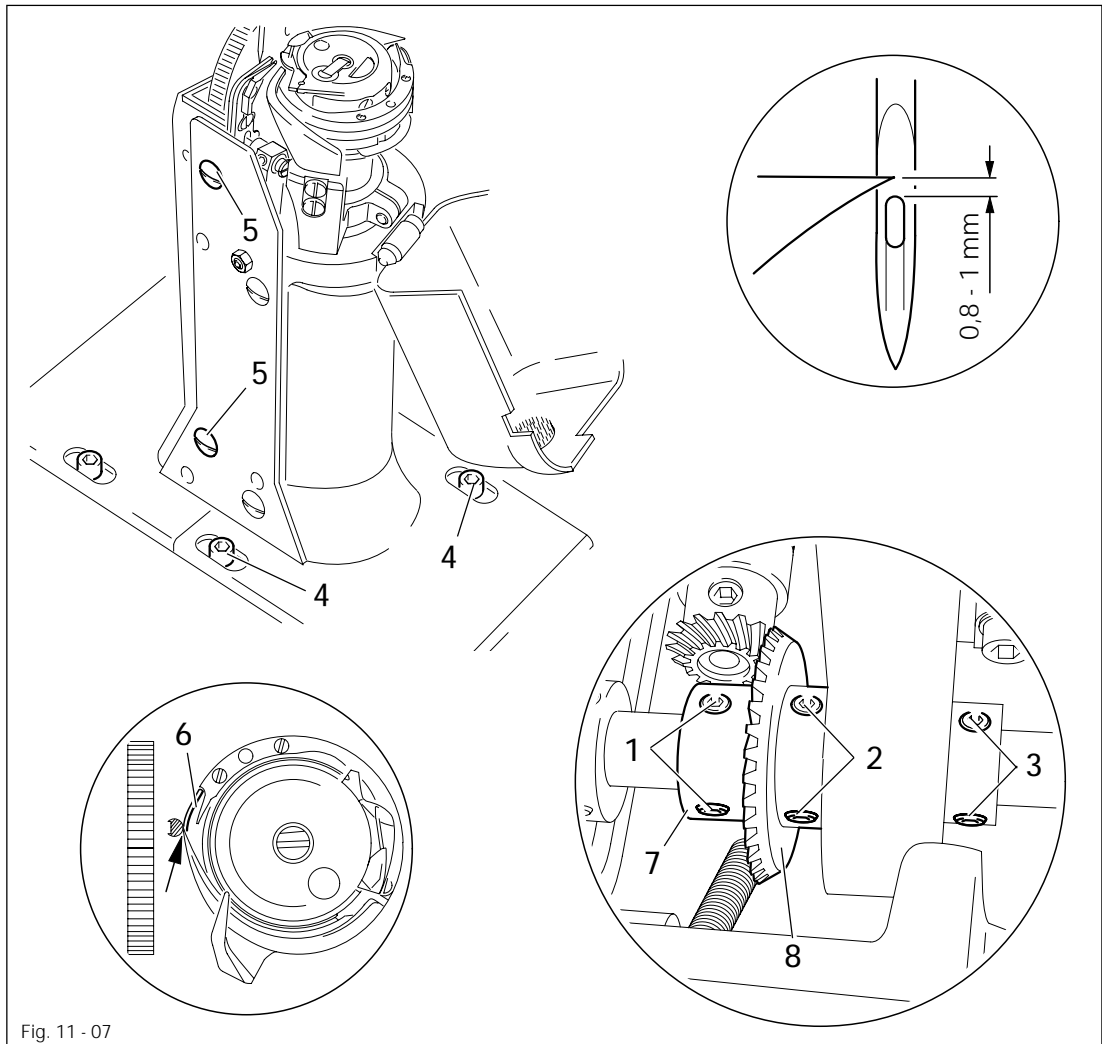
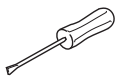

Fig. 11 - 07



- Set stitch length at "0.8".
- Loosen screws 1, 2, 3, 4 and 5.
- Bring needle bar to 1.8 mm past BDC:
- Set hook point at needle centre, making sure that the needle is not deflected by needle guard 6.
- Adjust needle height according to **Requirement 2**.
- Adjust hook post according to **Requirement 1** and tighten screws 4.
- Making sure that there is some play in the bevel gear, tighten screws 2.
- With retaining collar 7 touching bevel gear 8 tighten screws 1.
- Screws 5 remain loosened for further adjustments.



- Adjust needle guard 6 according to Requirement 3.



When the hook is replaced, care must be taken to see that markings 9 and 10 are on the same side.

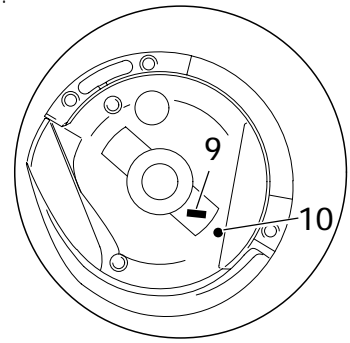

## Adjustment

### 11.04.08 Needle position crosswise to sewing direction on the PFAFF 471

#### Requirement

When the stitch length is set at its maximum, the needle must be positioned in the centre of the needle hole when entering and coming out of the needle plate.

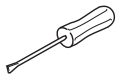
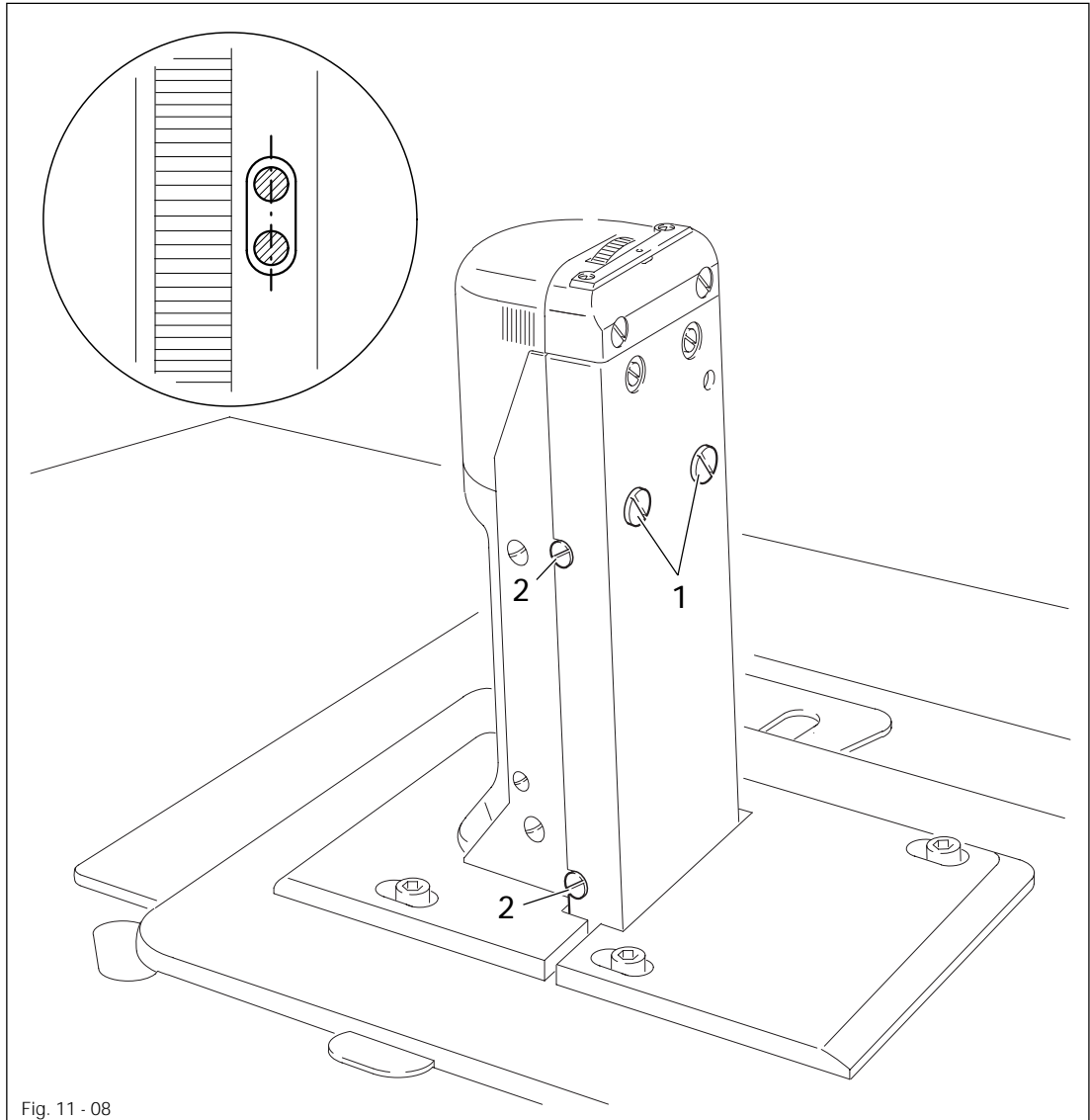

- Turn screws 1 (screws 2, on both sides of the post) according to the requirement.

## 11.04.09 Needle position crosswise to sewing direction on the PFAFF 474

### Requirement

As seen crosswise to the sewing direction, the needles must penetrate in the centre of their needle holes.

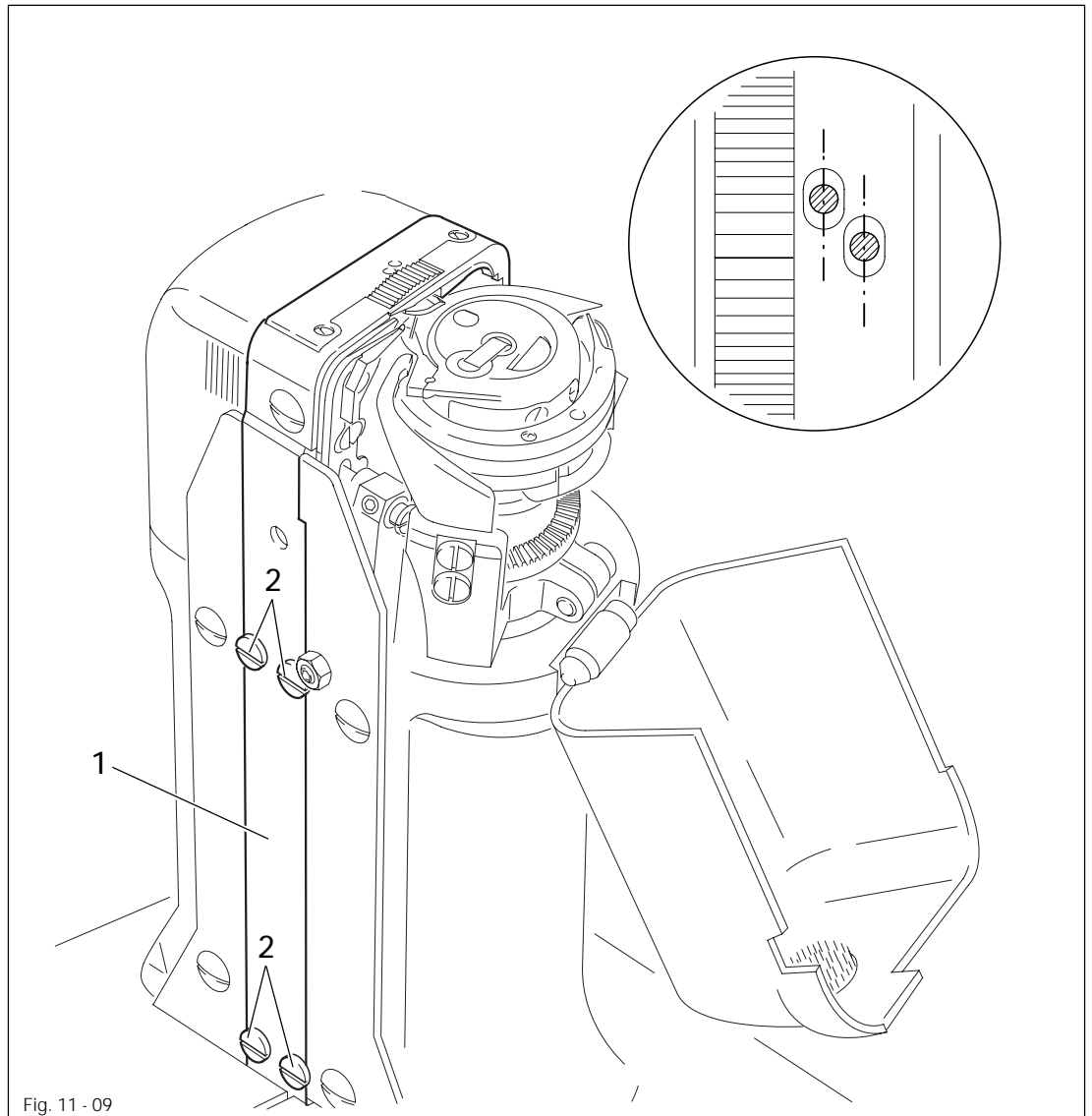

Fig. 11 - 09

- Adjust feed wheel post 1 (screws 2, on both sides of the post) according to the requirement.

## 11.04.10 Needle position crosswise to sewing direction on the PFAFF 491

### Requirement

As seen crosswise to the sewing direction, the needle must penetrate in the centre of the needle hole.

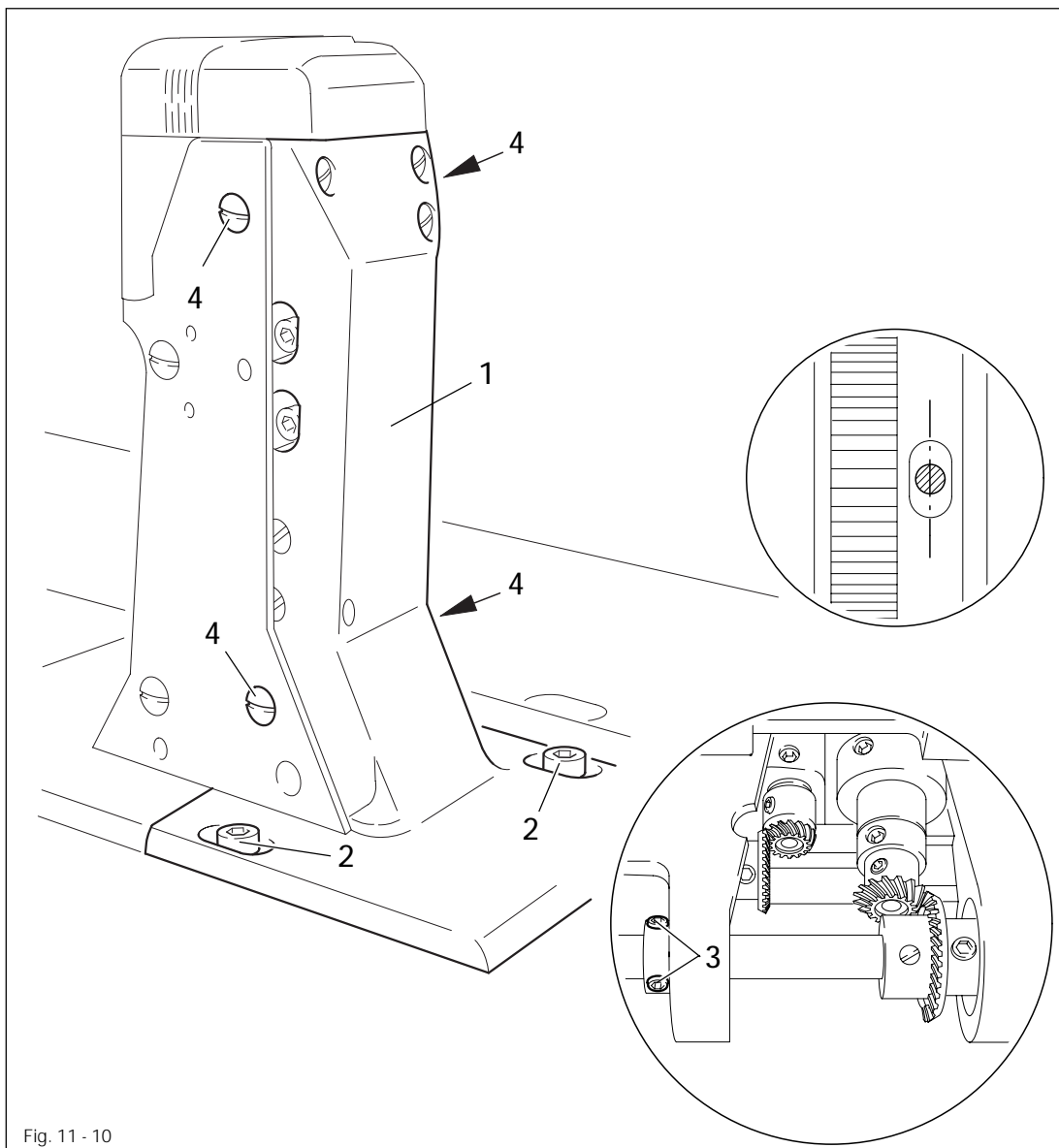
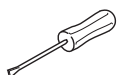

Fig. 11 - 10



- Adjust feed wheel post 1 (screws 2, 3 and 4) according to the requirement.

## 11.04.11 Height of the bobbin-case opener

### Requirement

The top edges of the bobbin-case opener 1 and the bobbin case base 3 must be level.

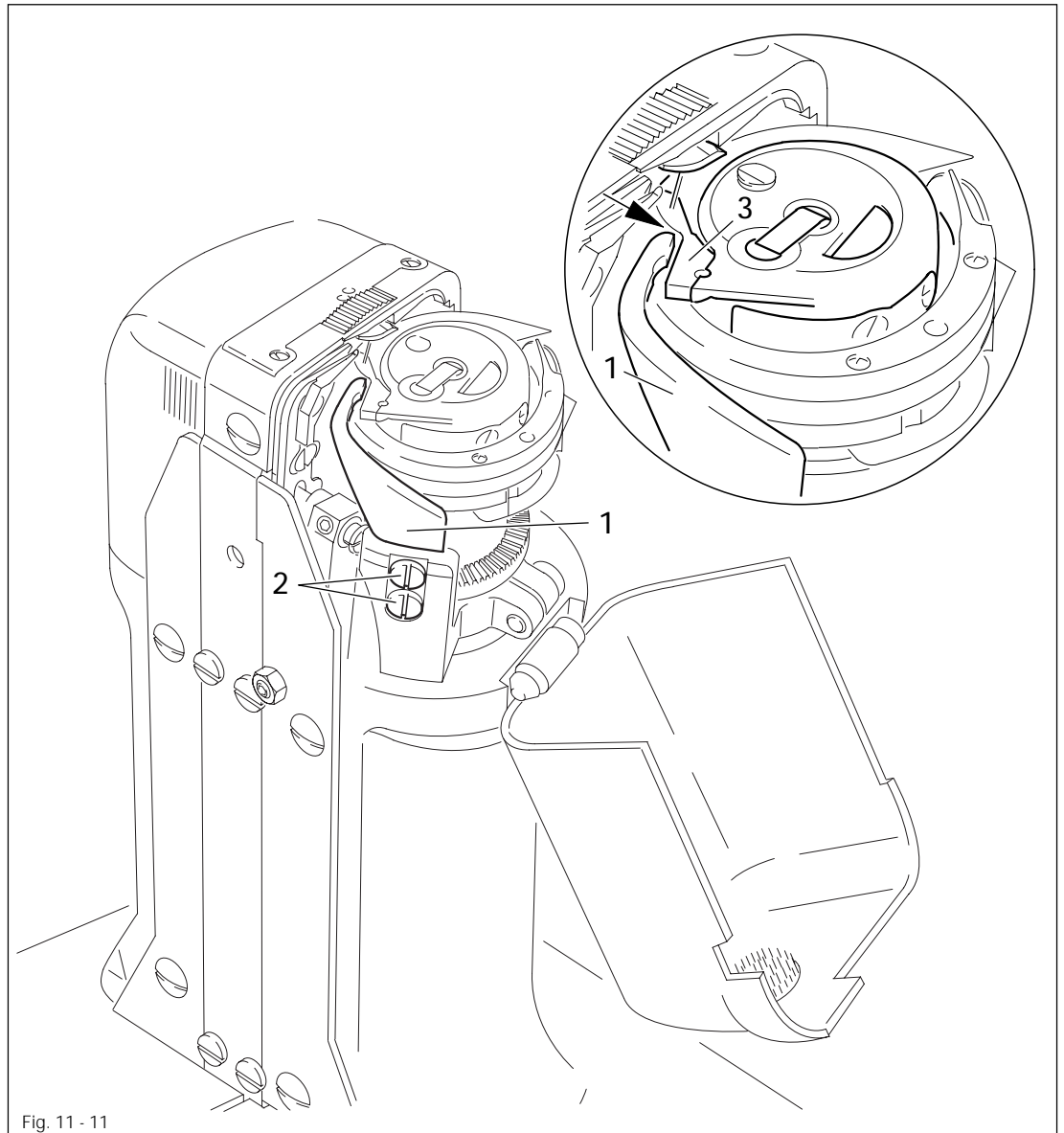
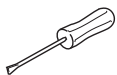

Fig. 11 - 11



- Adjust the bobbin-case opener 1 (screws 2) according to the requirement.



Repeat the adjustment on the right-hand post for the 474.

## 11.04.12 Bobbin-case opener stroke

### Requirement

When the bobbin-case opener has pushed the bobbin case down as far as possible, the tip of the bobbin case must be 0.3 - 0.5 mm from the rear edge of the needle plate recess.

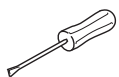
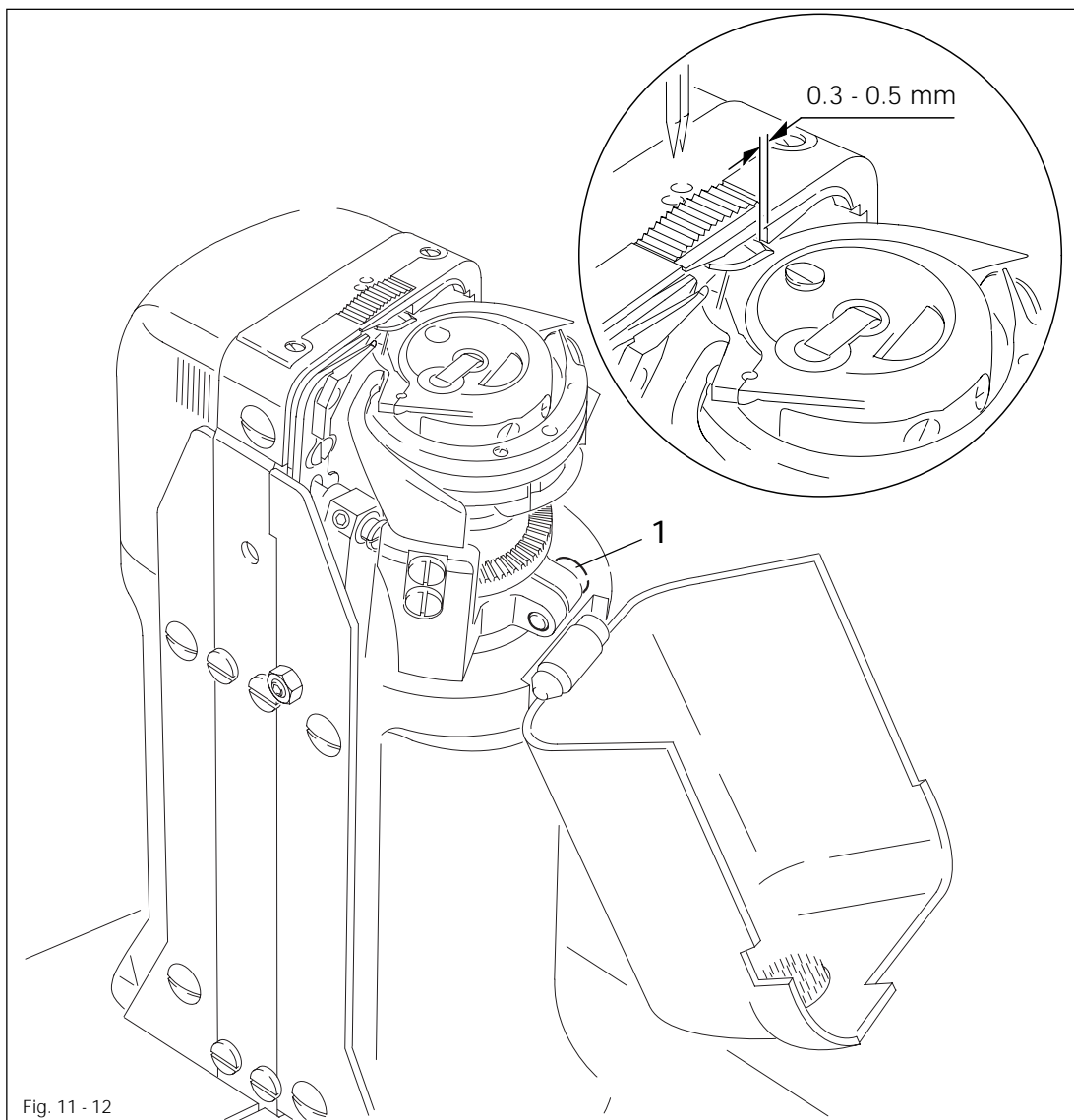

- Turn the balance wheel until the bobbin-case opener has pushed the bobbin case down as far as possible.
- Adjust the bobbin-case base (screw 1) according to the **requirement**.



Repeat the adjustment on the right-hand post for the 474.



This setting may differ according to the thread thickness.

## 11.04.13 Height of the feed wheel on the PFAFF 471

**Requirement**

1. When pressure is applied to the feed wheel 4, it should protrude from the needle plate by tooth height (approx. 0.8 mm)
2. When no pressure is applied to the feed wheel 4, it should have a vertical play of approx. 0.3 mm.

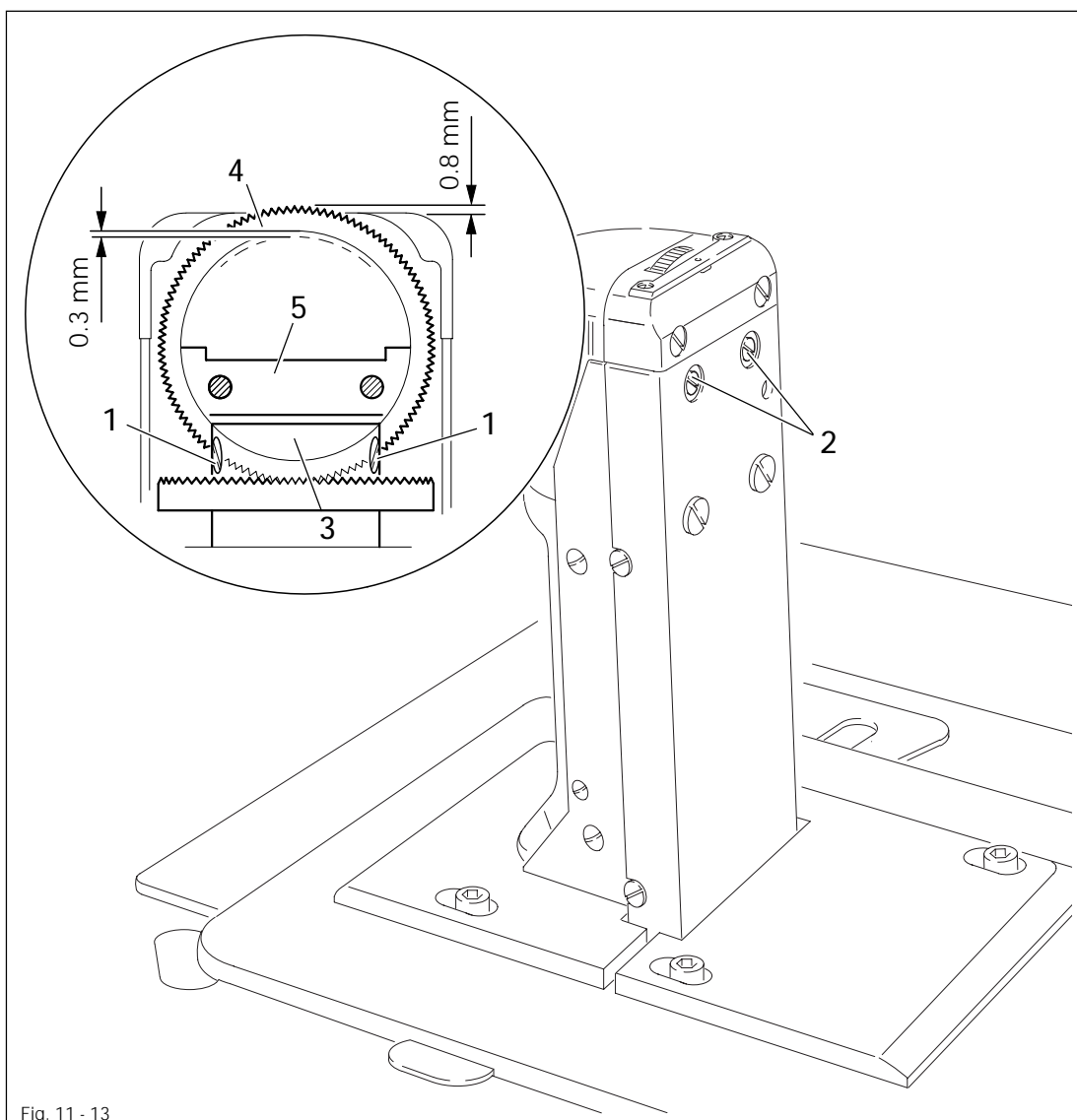
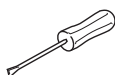

Fig. 11 - 13



- Swing out the roller presser.
- Loosen screws 1 and 2.
- Adjust drive wheel 3 according to **requirement 1**, taking care to see that the teeth of drive wheel 3 and feed wheel 4 lock into each other properly.
- Tighten screws 1.
- Adjust guide 5 according to **requirement 2** and tighten screws 2.

## 11.04.14 Height of the feed wheel on the PFAFF 474

### Requirement

1. When pressure is applied to the feed wheel 4, it should protrude from the needle plate by tooth height (approx. 0.8 mm)
2. When no pressure is applied to the feed wheel 4, it should have a vertical play of approx. 0.3 mm.

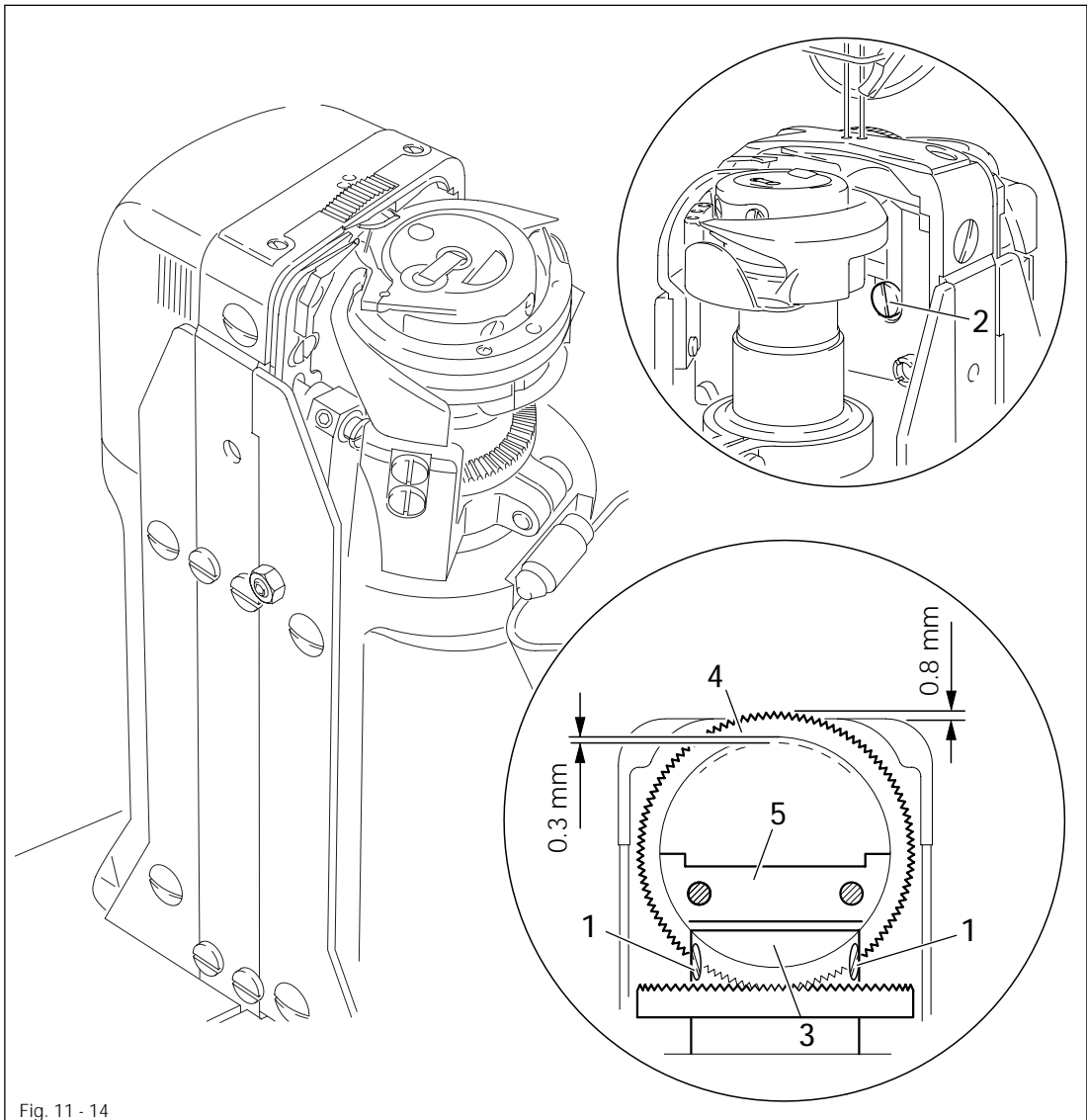
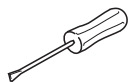

Fig. 11 - 14



- Swing out the roller presser.
- Loosen screws 1 and 2 (two screws).
- Adjust drive wheel 3 according to **requirement 1**, taking care to see that the teeth of drive wheel 3 and feed wheel 4 lock into each other properly.
- Tighten screws 1.
- Adjust guide 5 according to **requirement 2** and tighten screws 2.



## 11.04.15 Height of the feed wheel on the PFAFF 491

### Requirement

The feed wheel should protrude from the needle plate by tooth height (approx. 0.8 mm)

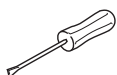
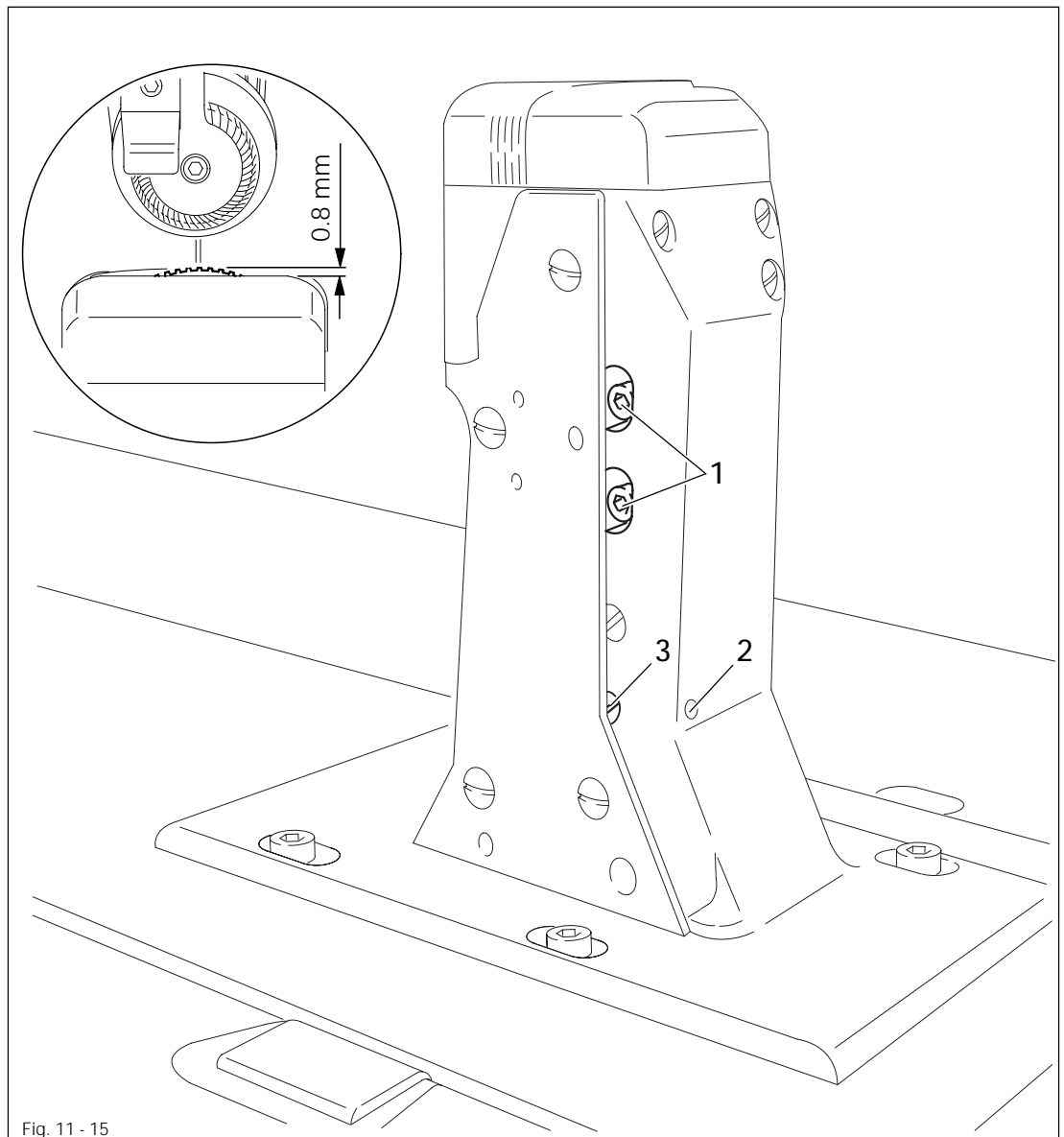

- Swing out the roller presser.
- Loosen screws 1.
- Adjust eccentric 3 (fastening screw accessible through hole 2) according to the requirement.
- Tighten screws 1.

## 11.04.16 Stitch length control eccentric

### Requirement

When the needle (with maximum stitch length set), coming from TDC, is **3 mm** above the needle plate, the crank **3** must have reached its front point of reversal.

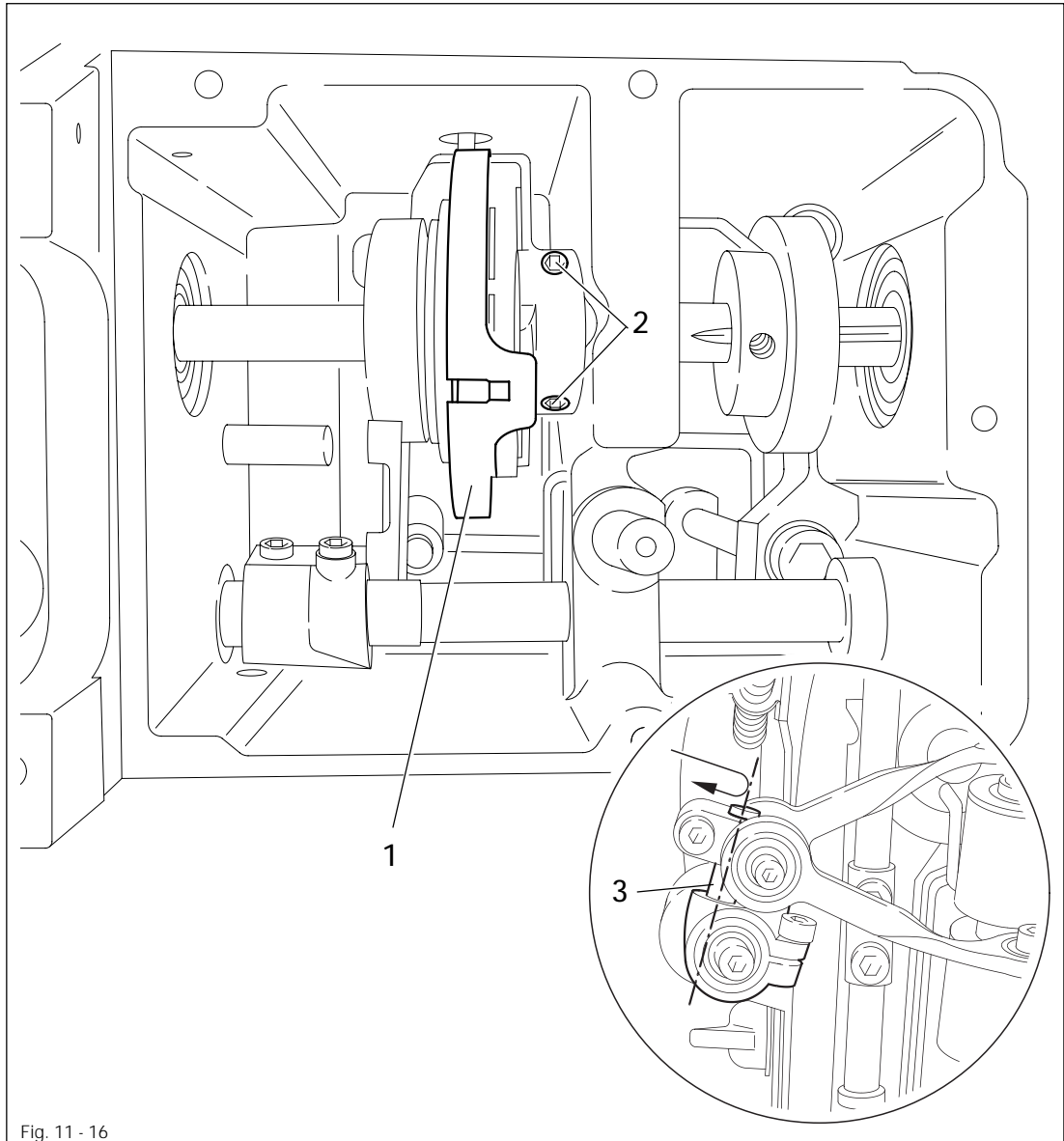
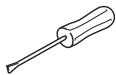

Fig. 11 - 16



- Set the maximum stitch length.
- Turn stitch length control device 1 (screws 2) according to the requirement.

## 11.04.17 Stitch length scale disk

### Requirement

When the stitch length control device is locked in position, and the maximum stitch length is set, the marking line of the highest number on the scale disk 1 must be opposite the lower edge 3 of the belt guard recess.

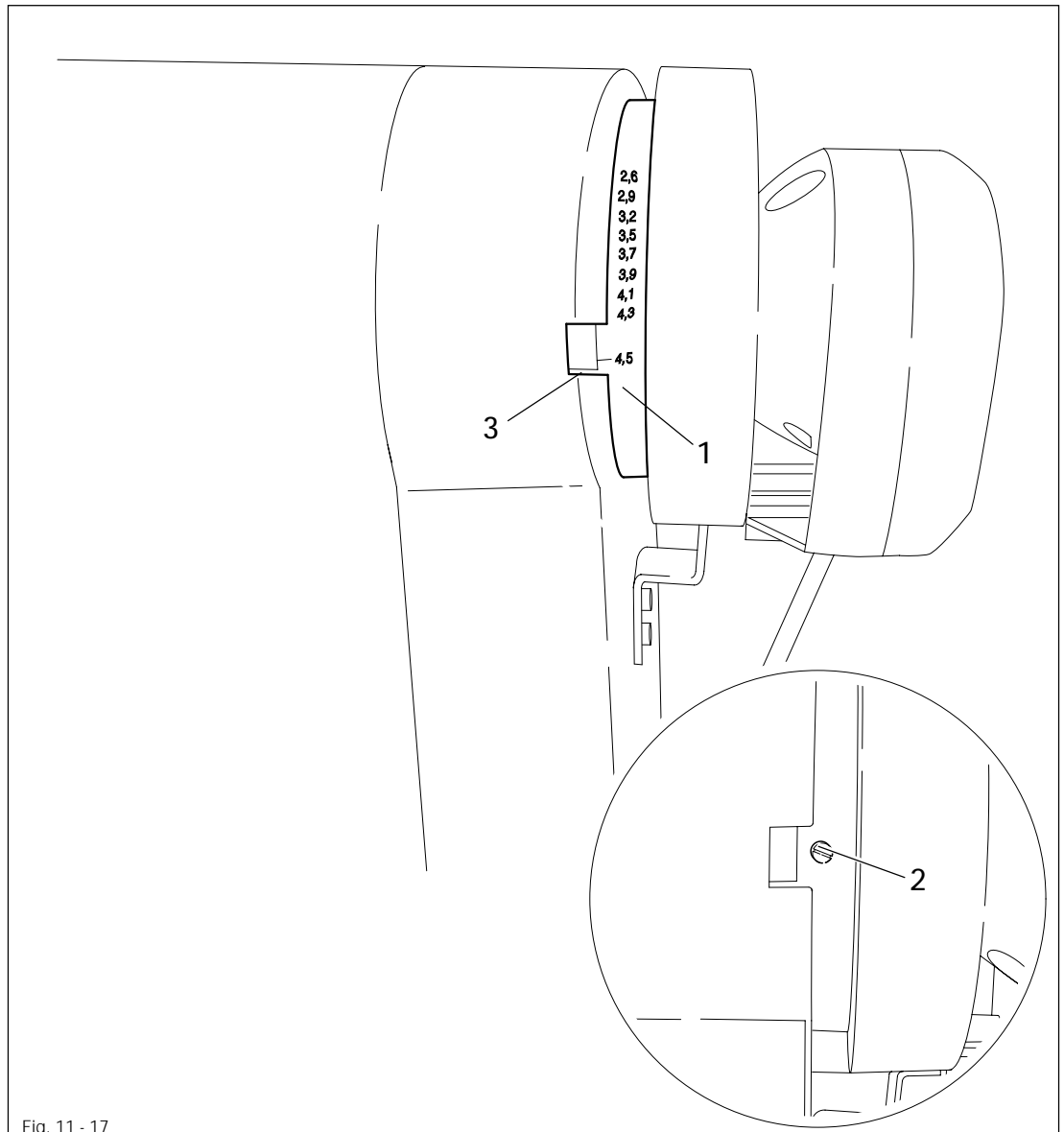
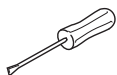

Fig. 11 - 17



- Set the maximum stitch length.
- Turn the scale disk 1 (screws 2) according to the requirement.

# Adjustment

## 11.04.18 Shaft crank to feed wheel drive

### Requirement

When the maximum stitch length is set, the linkage rod 3, or linkage rods 3 and 4 on the models 471 and 491, must be able to move freely when the balance wheel is turned.

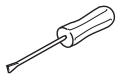
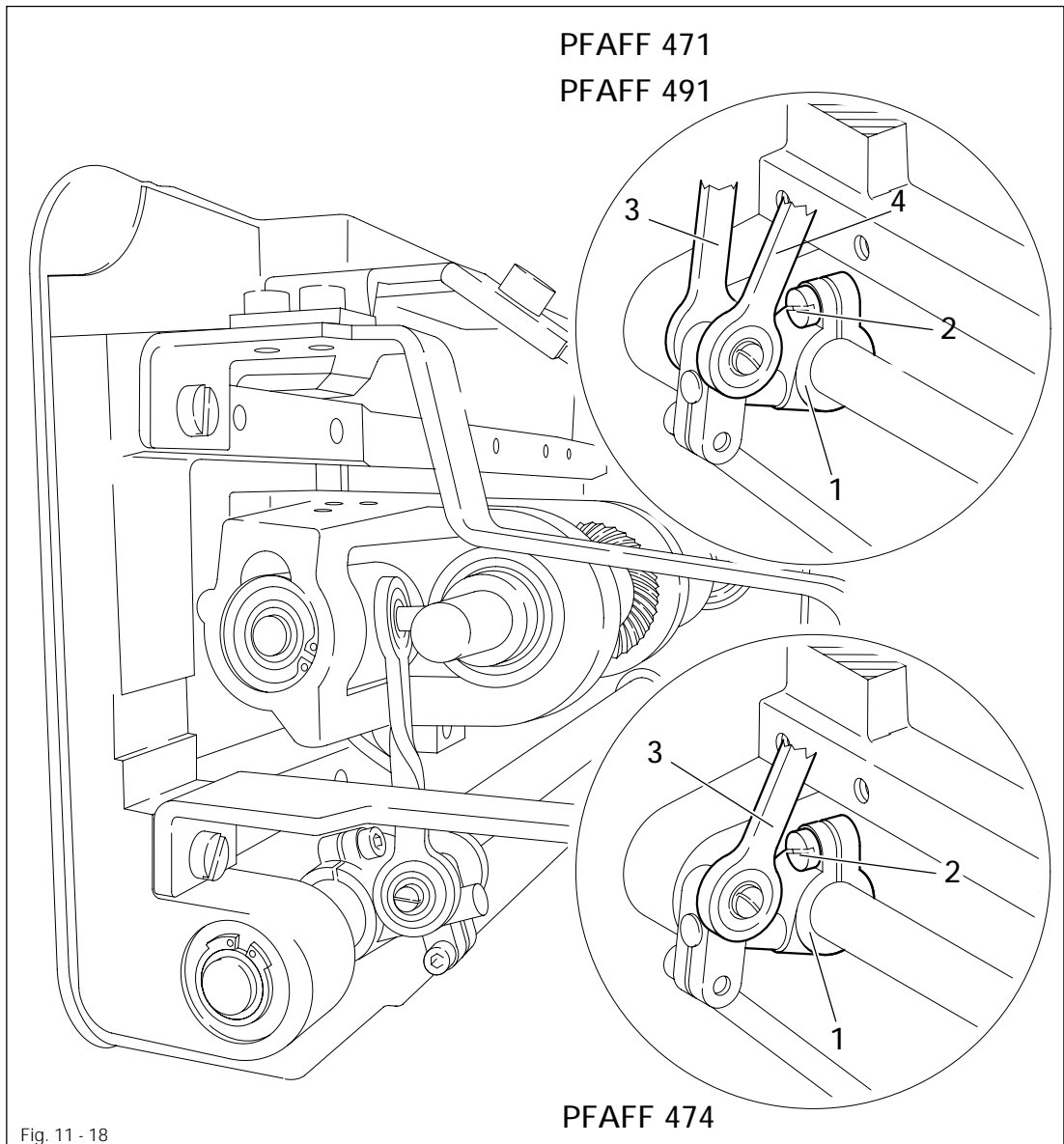

- Set the maximum stitch length.
- Twist or shift the shaft crank 1 (screw 2) according to the requirement.

## 11.04.19 Shaft crank to roller presser drive

### Requirement

When the maximum stitch length is set, the linkage rods 3 and 4 must be able to move freely at their left and right point of reversal when the balance wheel is turned.

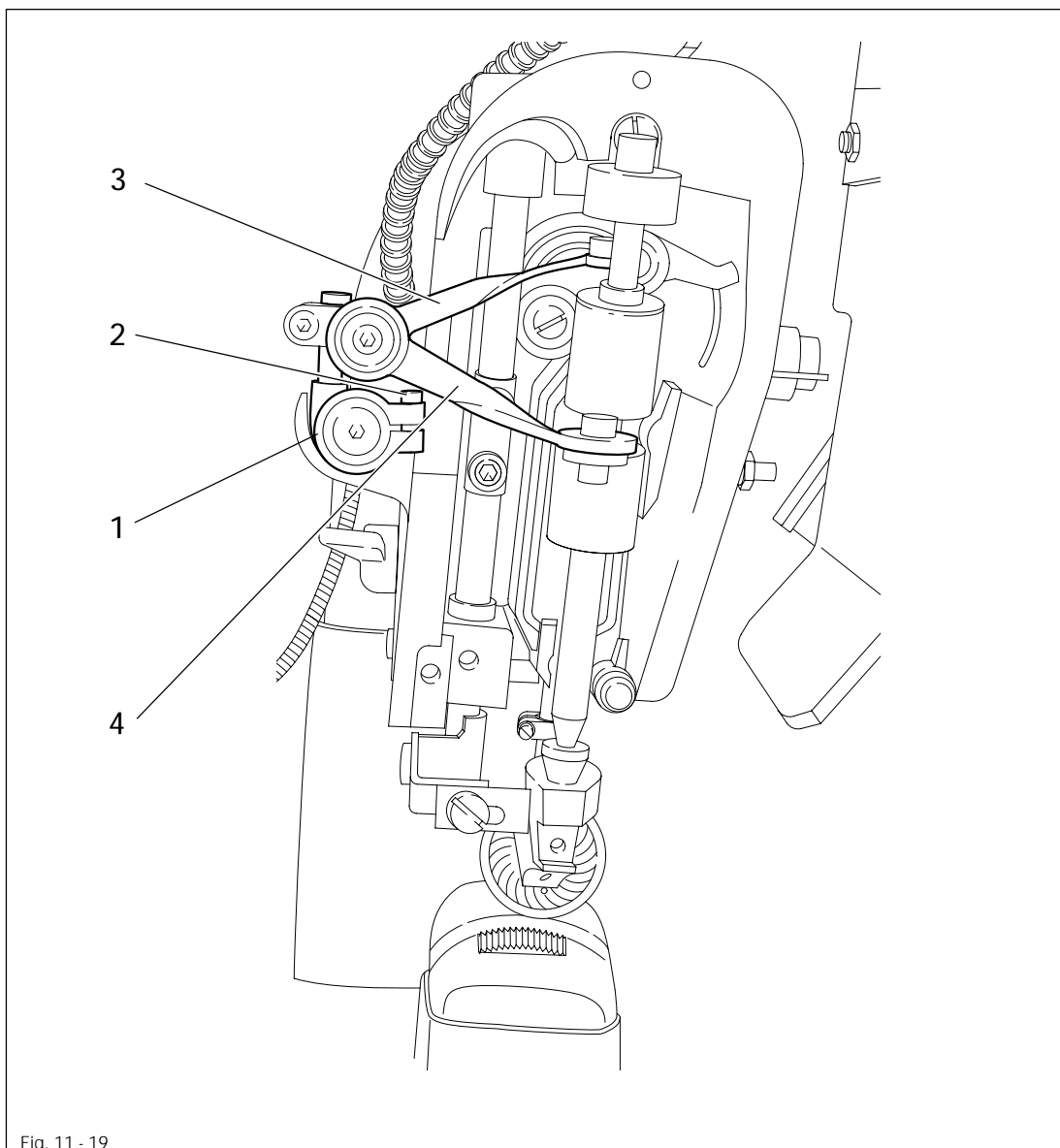

- Set the maximum stitch length.
- Twist clamp crank 1 (screw 2) according to the requirement.

## Adjustment

### 11.04.20 Clearance between roller presser and feed wheel

#### Requirement

When the presser bar lifter is raised, the clearance between the roller presser and the feed wheel must be 7 mm.

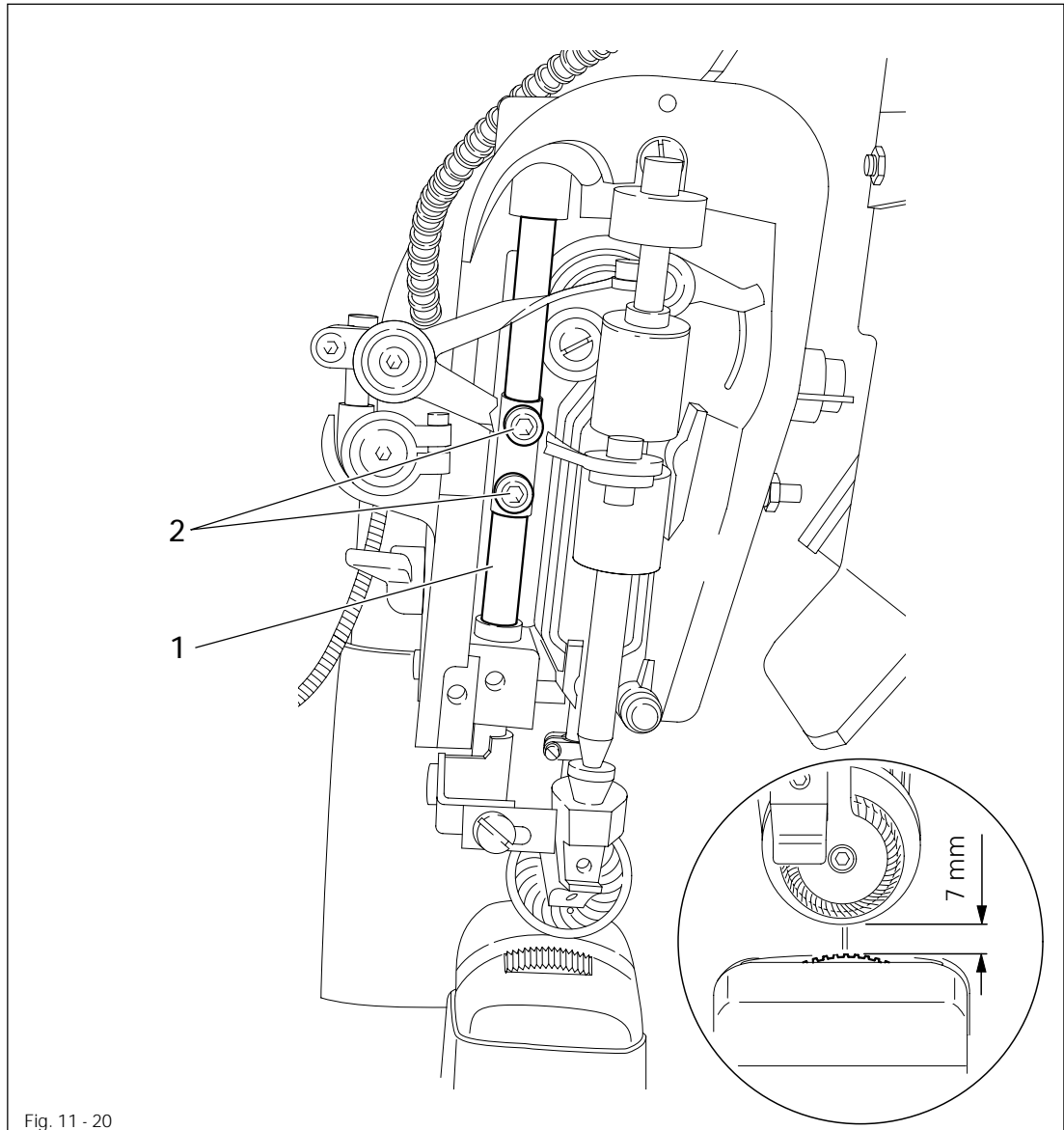
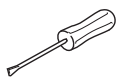

Fig. 11 - 20



- Raise the presser bar lifter.
- Adjust the presser bar 1 (screws 2) according to the **requirement**. Make sure that the roller presser is parallel to the feed wheel.

## 11.04.21 Roller presser

**Requirements**

When the roller presser 1 is touching the feed wheel 5 it must

1. be parallel to feed wheel 5, as seen in the direction of sewing,
2. be in the centre of the needle (on model 474 the left needle), as seen in the direction of sewing,
3. be as near as possible to the needle (on model 474 the left needle), as seen crosswise to the direction of sewing.

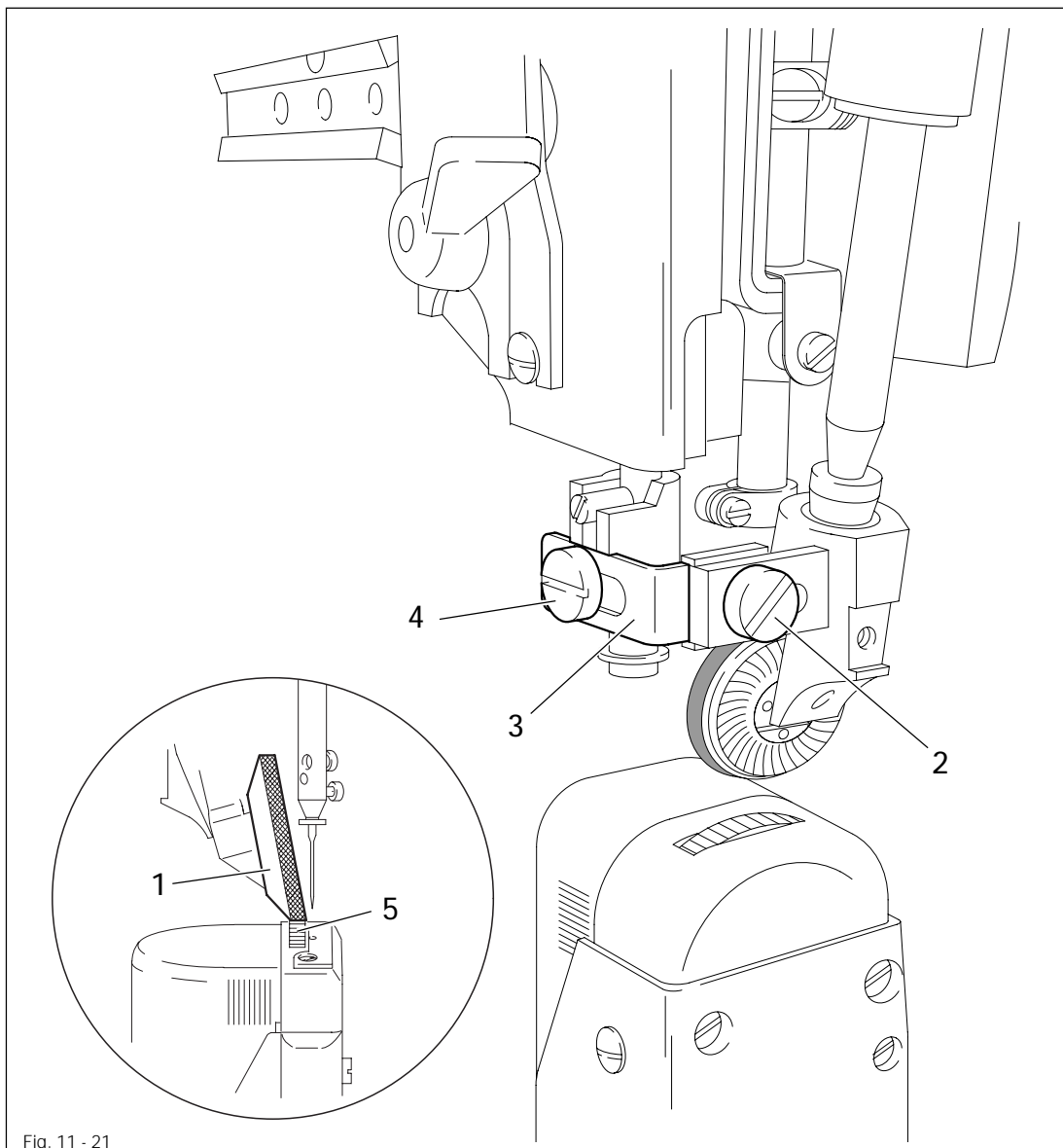
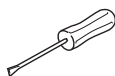

Fig. 11 - 21



- Raise the roller presser.
- Always observe **requirement 1** for subsequent adjustments.
- Adjust roller presser 1 (screw 2) according to **requirement 2**.
- Lower roller presser 1 to rest on feed wheel 5.
- Adjust roller presser bracket 3 (screw 4) according to **requirement 3**.



When sewing very tight curves, the roller presser 1 must be moved a little towards the operator.

# Adjustment

## 11.04.22 Stitch length on stitch length scale

### Requirement

When the stitch length is set at "3", and after the needle has entered a strip of leather 11 times, the total length from the first to last needle penetration must be 30 mm.

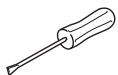
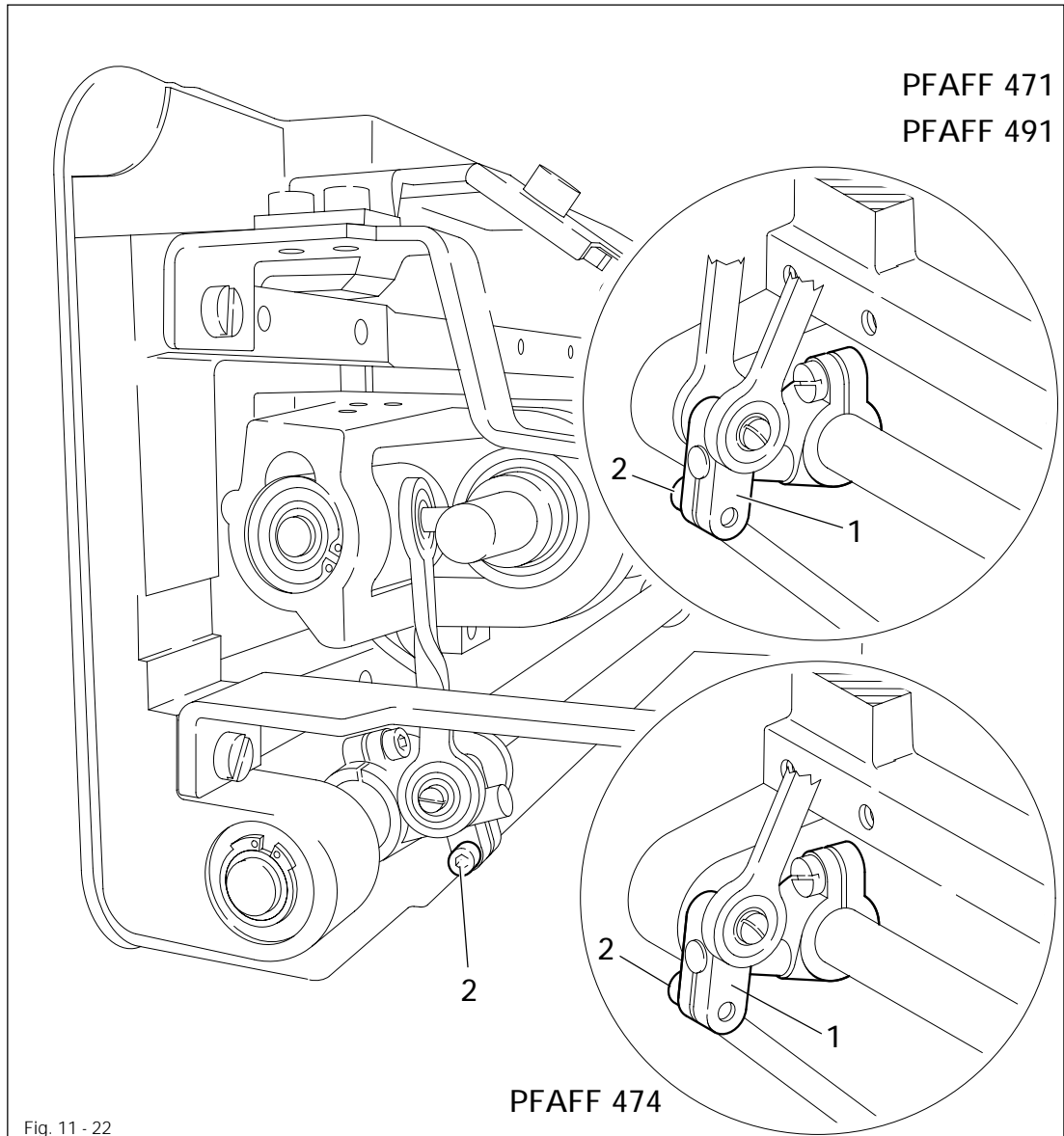

- Set stitch length "3".
- By turning the balance wheel, let the needle enter 11 times and measure the total length.
- Adjust clamp 1 (screw 2) according to the requirement.



Clamp 1 must not be positioned diagonally to the rock shaft!



## 11.04.23 Synchronization of roller presser and feed wheel

**Requirement**

After 21 needle penetrations in a strip of leather the total length from the first to the last penetration should be the same, both in the lower and the upper leather layer.

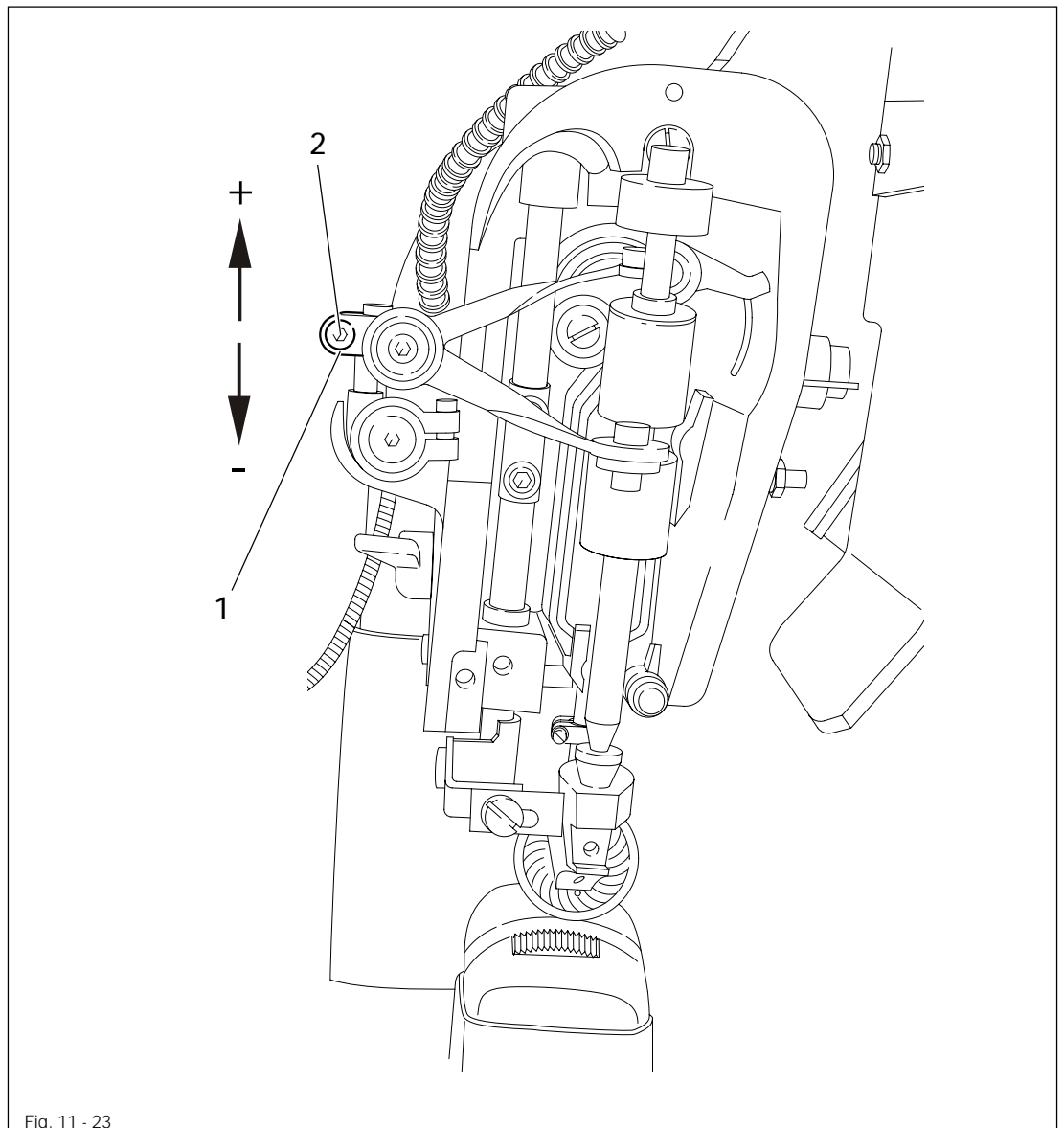
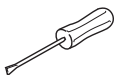

Fig. 11 - 23



- Set stitch length "3".
- By turning the balance wheel, let the needle enter 21 times.
- Compare the total sewn length of the lower and upper leather layer.
- Adjust clamp 1 (screw 2) according to the requirement.



Clamp 1 must not be positioned diagonally to the rock shaft.

## 11.04.24 Retainer (only on model 474)

### Requirements

The retainer 1 must

1. be as close as possible to the needle, as seen in the direction of sewing and
2. be in the centre of the needle, as seen crosswise to the direction of sewing.
3. When the roller presser is lowered, the distance between the retainer 1 and the workpiece must be 0.2 - 0.3 mm.

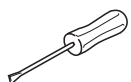
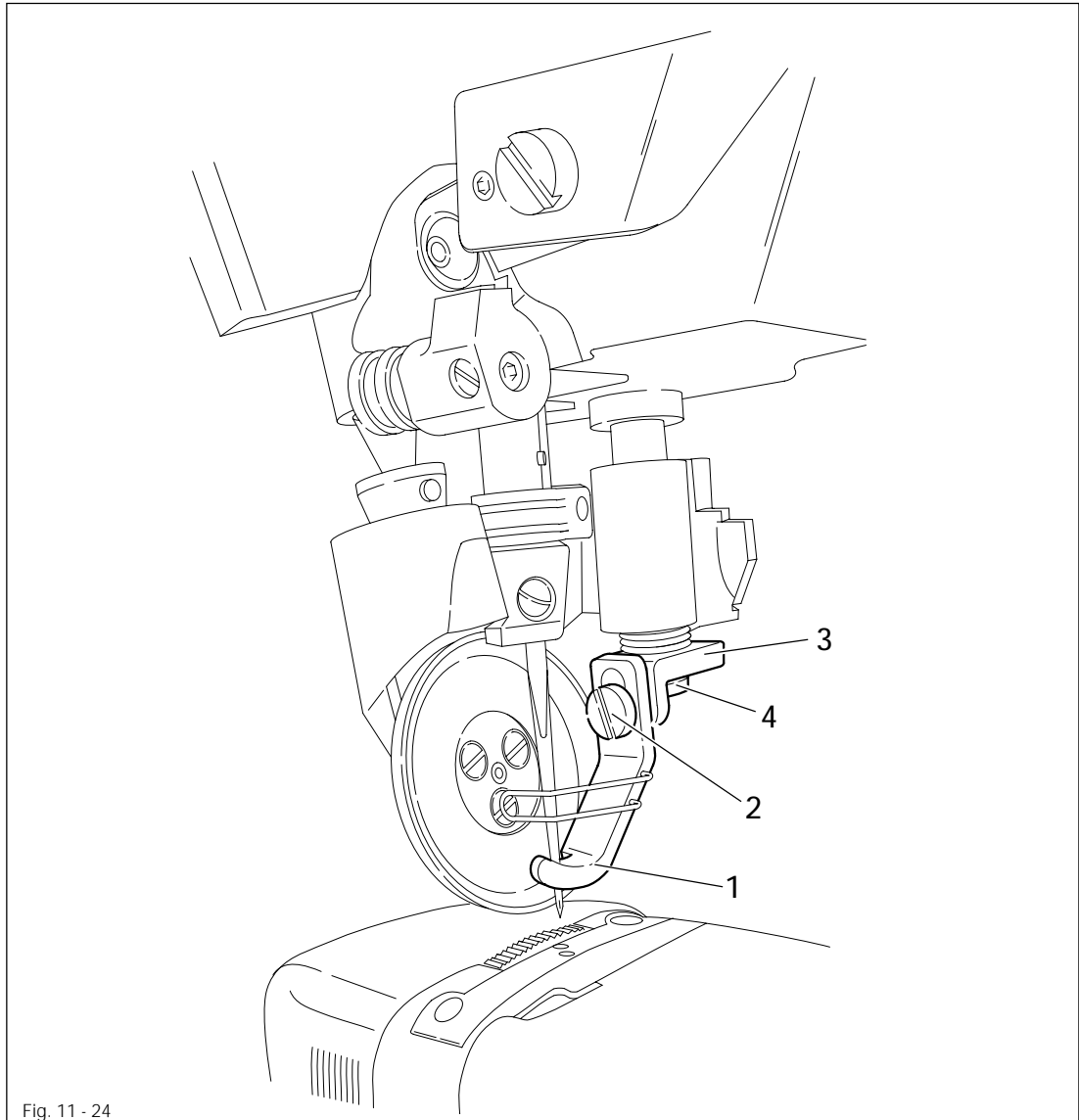

- Adjust retainer 1 (screw 2) according to requirement 3.
- Adjust bracket 3 (screw 4) according to requirement 1 and 2.

## 11.04.25 Knee lever

**Requirements**

1. Before the roller presser rises, the knee lever must still have a slight play.
2. When the knee lever is raised as far as possible, the lever for the roller presser must drop automatically.
3. Knee lever bar 5 must be at an angle of **approx. 75°** to the bedplate.

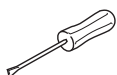
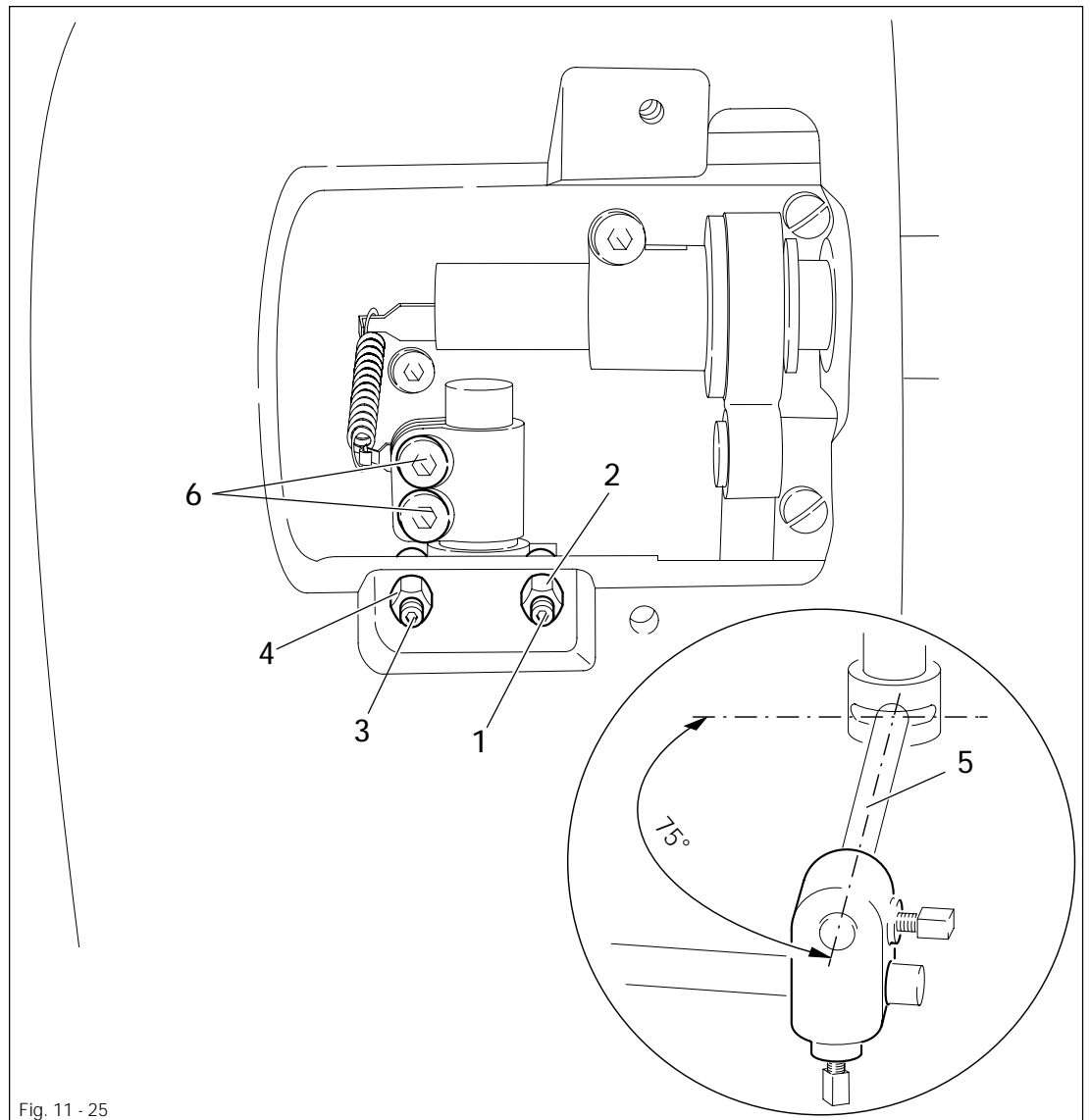

- Adjust screw 1 (nut 2) according to requirement 3.
- Adjust screw 3 (nut 4) according to requirement 2.
- Set bar 5 (Screws 6) according to requirement 3.

## 11.04.26 Needle thread tension release

### Requirements

1. When the presser bar lifter is raised, the tension discs 3 should be pressed at least 0.5 mm apart.
2. When the roller presser is lowered, the tension must be fully effective.

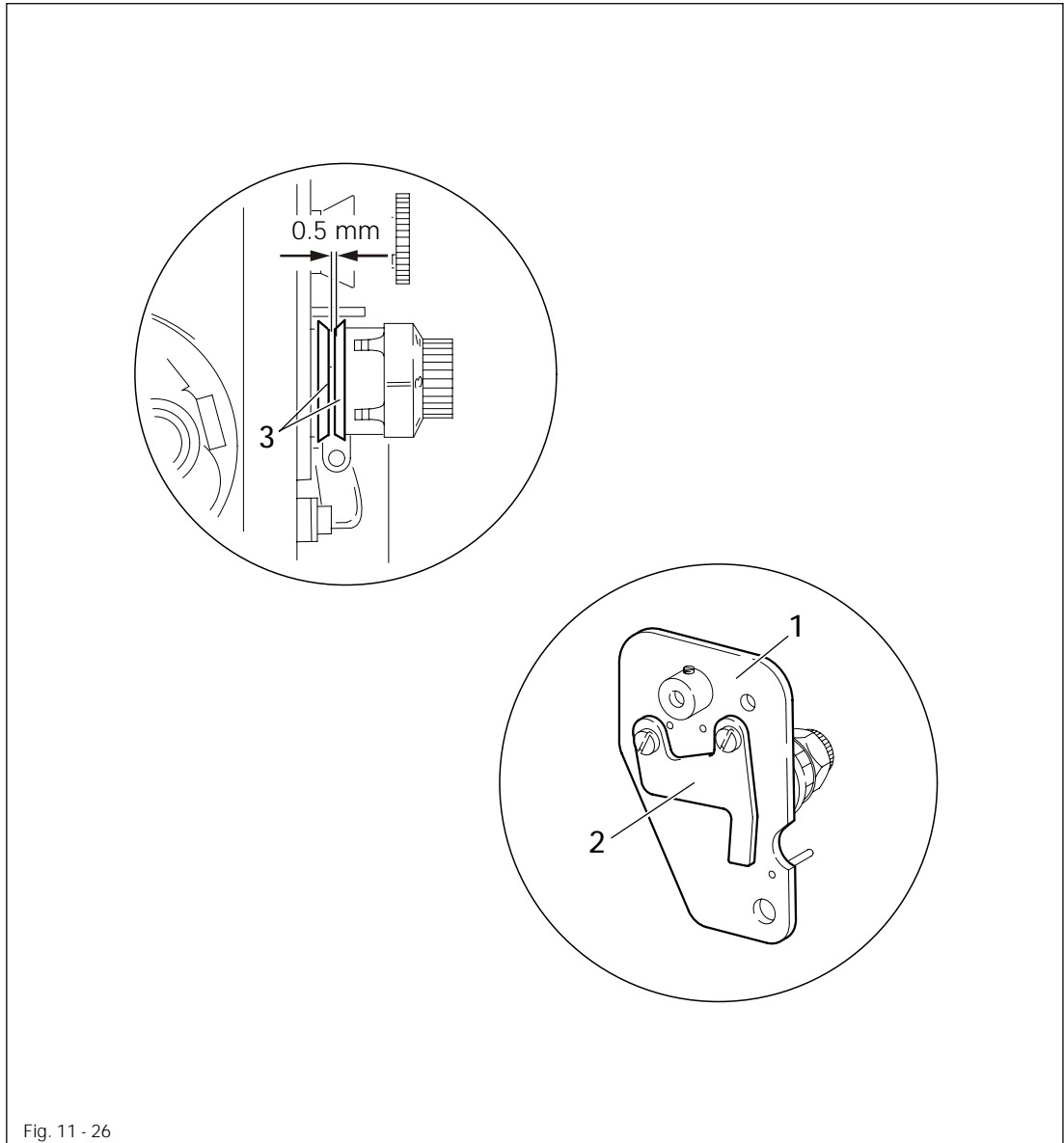
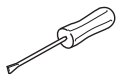

Fig. 11 - 26



- Align tension mounting plate 1 and pressure plate 2 according to the requirement.

## 11.04.27 Thread check spring

**Requirement**

1. The movement of thread check spring 5 must be completed when the needle point enters the material ( spring stroke approx. 7 mm).

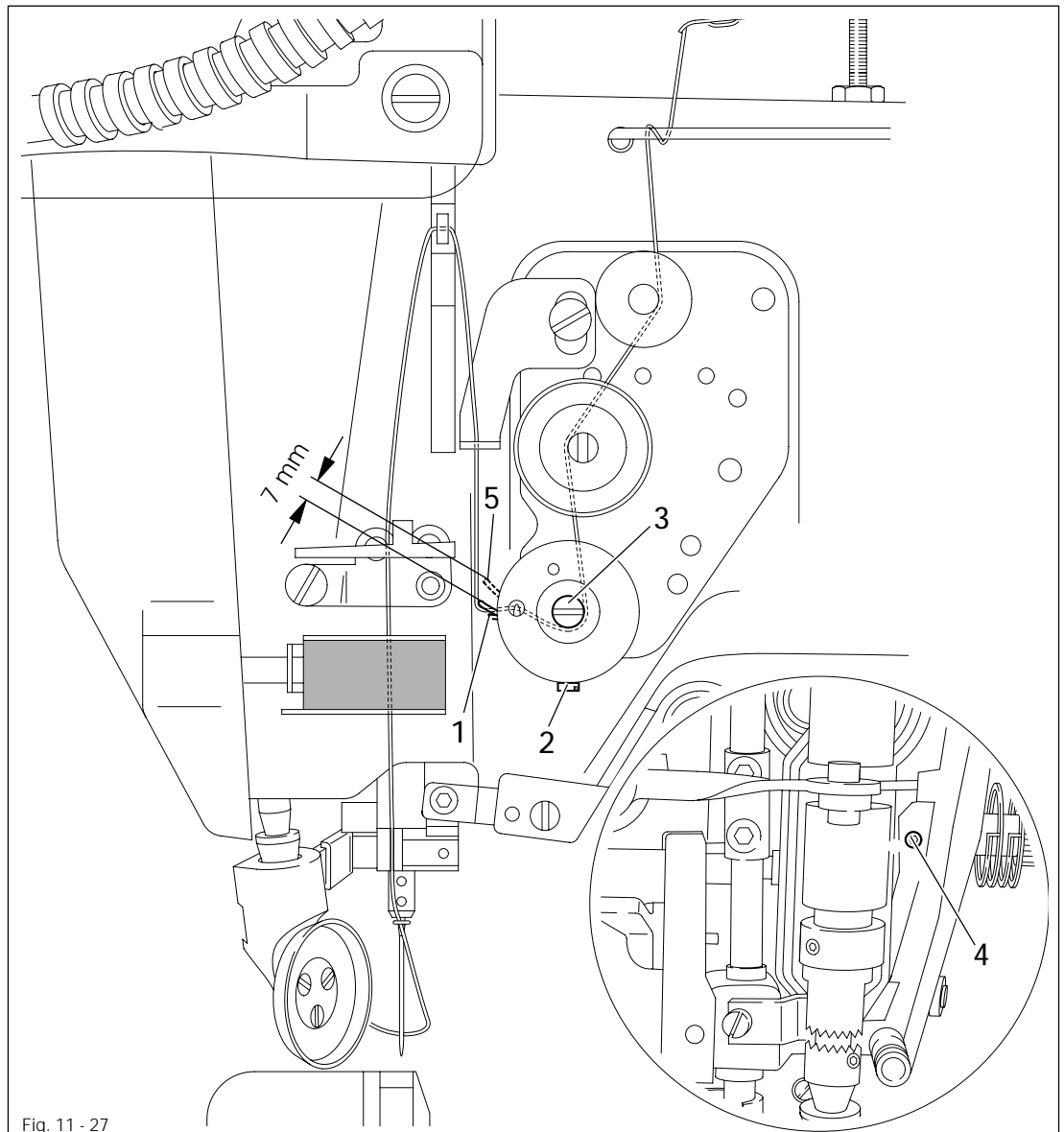

- Position rest 1 (screw 2) according to **requirement 1**.
- To adjust the spring tension, turn screw 3 (screw 4).



For technical sewing reasons it may be necessary to deviate from the indicated spring stroke or spring tension.

## 11.04.28 Bobbin winder

### Requirements

1. When the bobbin winder is engaged, the winding spindle must be driven reliably. When the bobbin winder is disengaged, the friction wheel 5 must not be moved by drive wheel 1.
2. The bobbin winder must switch itself off, when the filled thread is about **1 mm** from the edge of the bobbin.

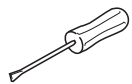
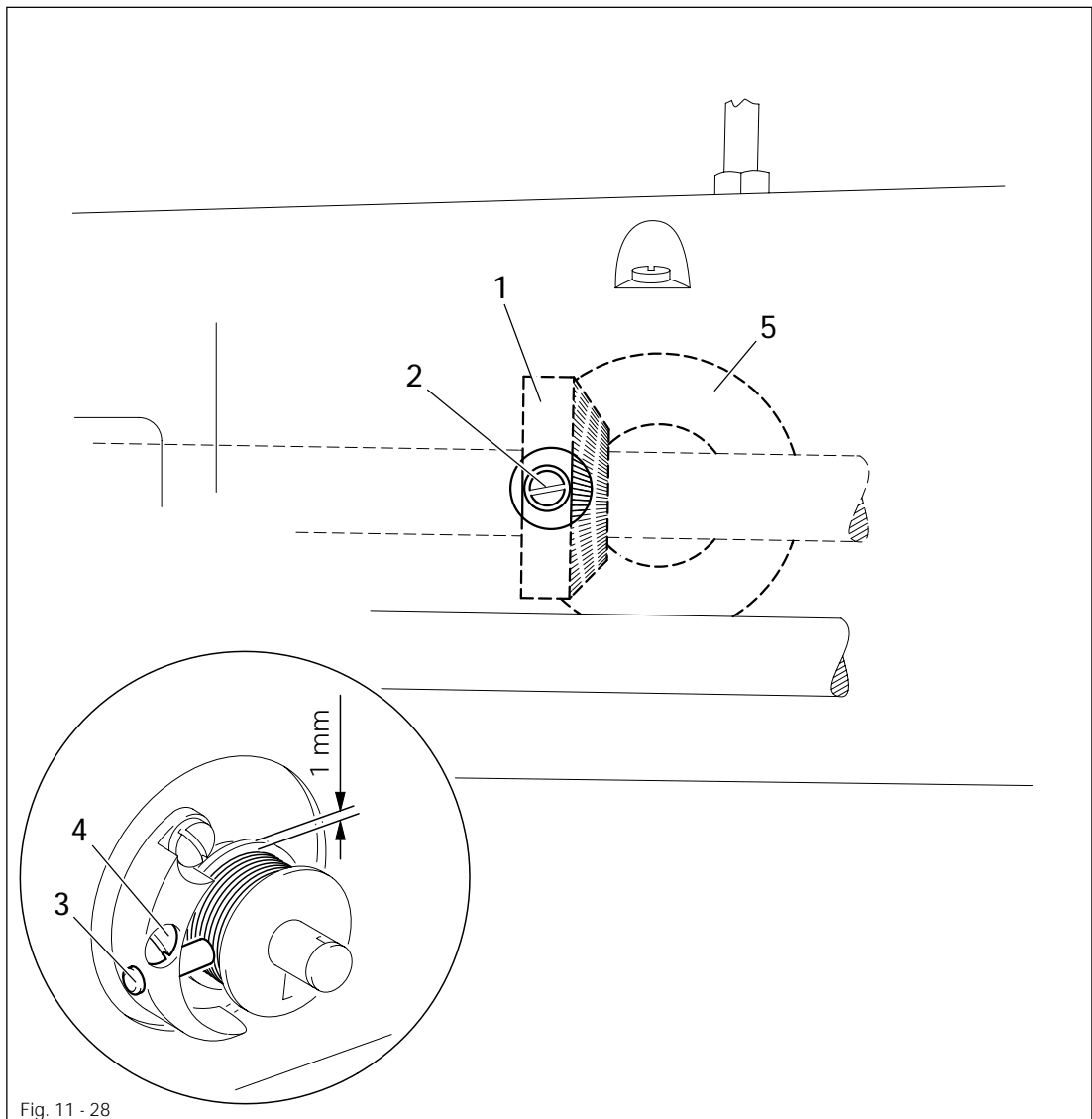

- Position drive wheel 1 (screws 2) according to requirement 1.
- Position bolt 3 (screw 4) according to requirement 2.

## 11.04.29 Pressure of roller presser

### Requirement

The material must be fed smoothly. No pressure marks should be visible on the material.

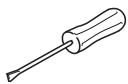
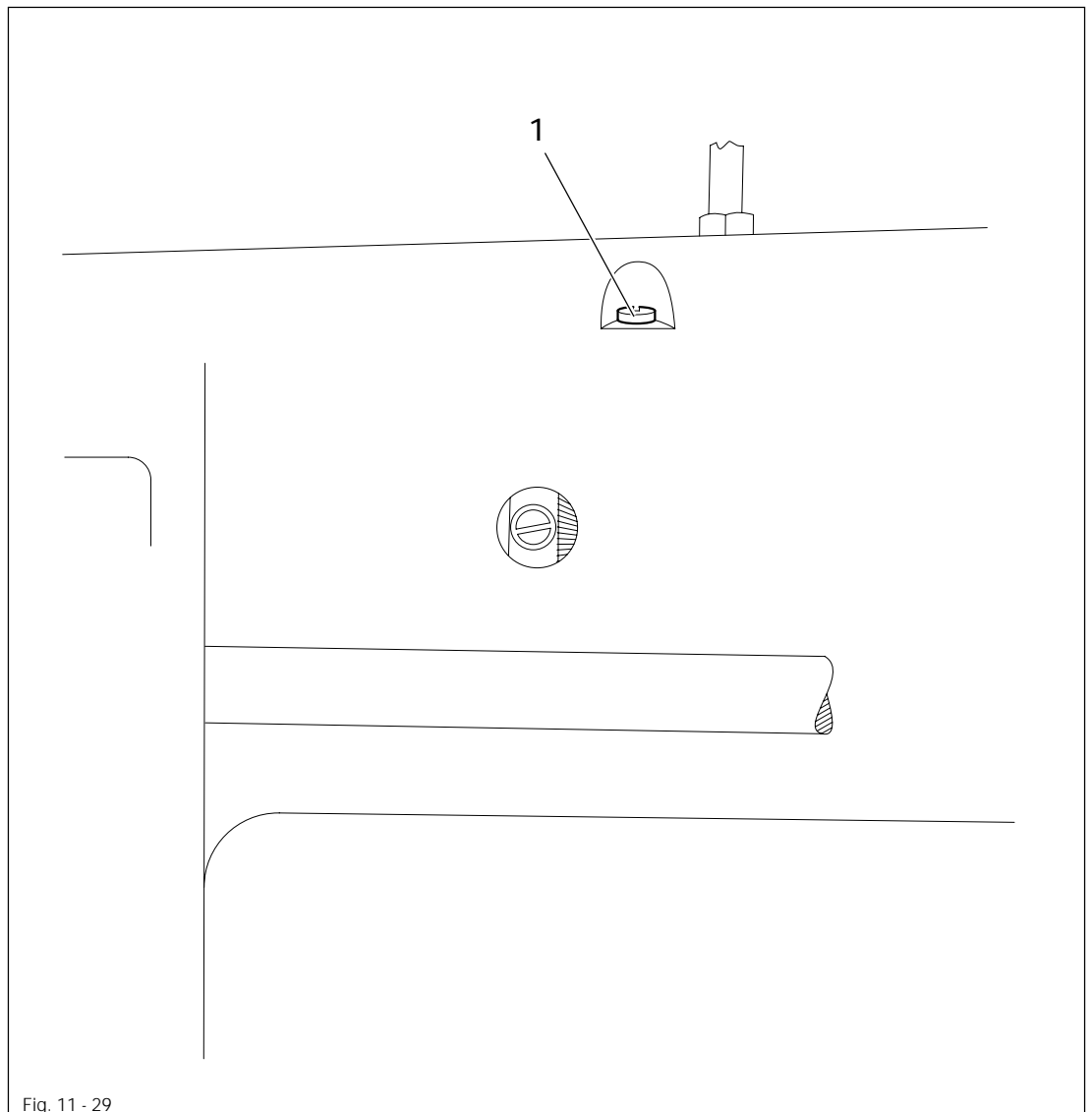

- Adjust roller presser pressure with screw 1 according to the requirement.

## 11.04.30 Re-engage safety coupling



The coupling 1 is set by the manufacturer. When the thread jams, the coupling 1 disengages in order to avoid damage to the hooks.  
A description of how to engage the coupling follows.

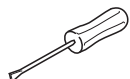
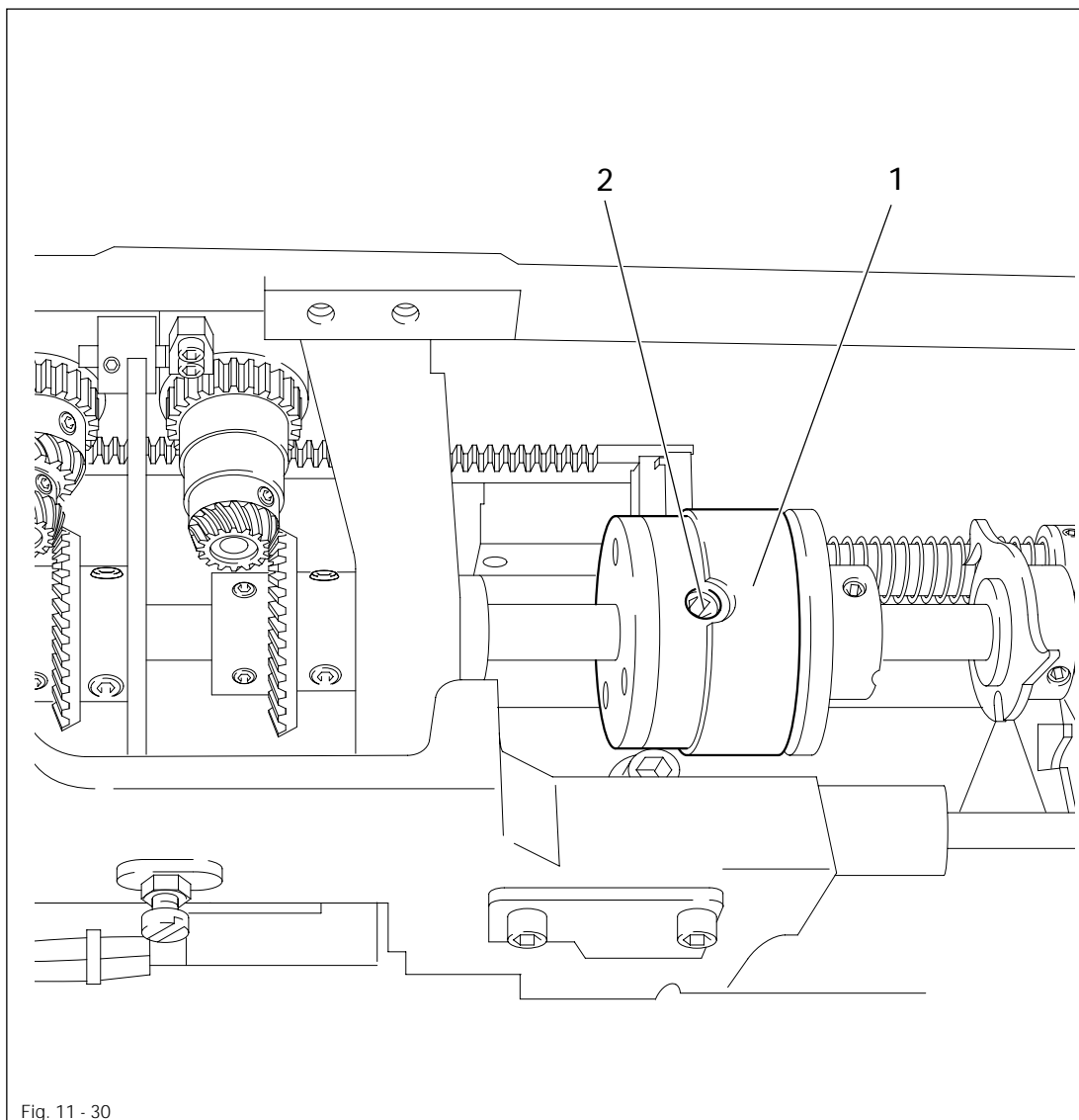

- Remove jammed thread.
- Hold coupling 1 with screw 2 and turn the balance wheel, until you feel coupling 1 snap back into place again.



## 11.05 Adjusting the edge trimmer -725/04

### 11.05.01 Position of the knife holder on model 471

#### Requirements

When the thread trimmer is engaged and the adjusting wheel has been turned to its highest position

1. the knife holder 2 must be parallel to the post and
2. the top edge of the needle plate must be in the centre of the angular knife opening.

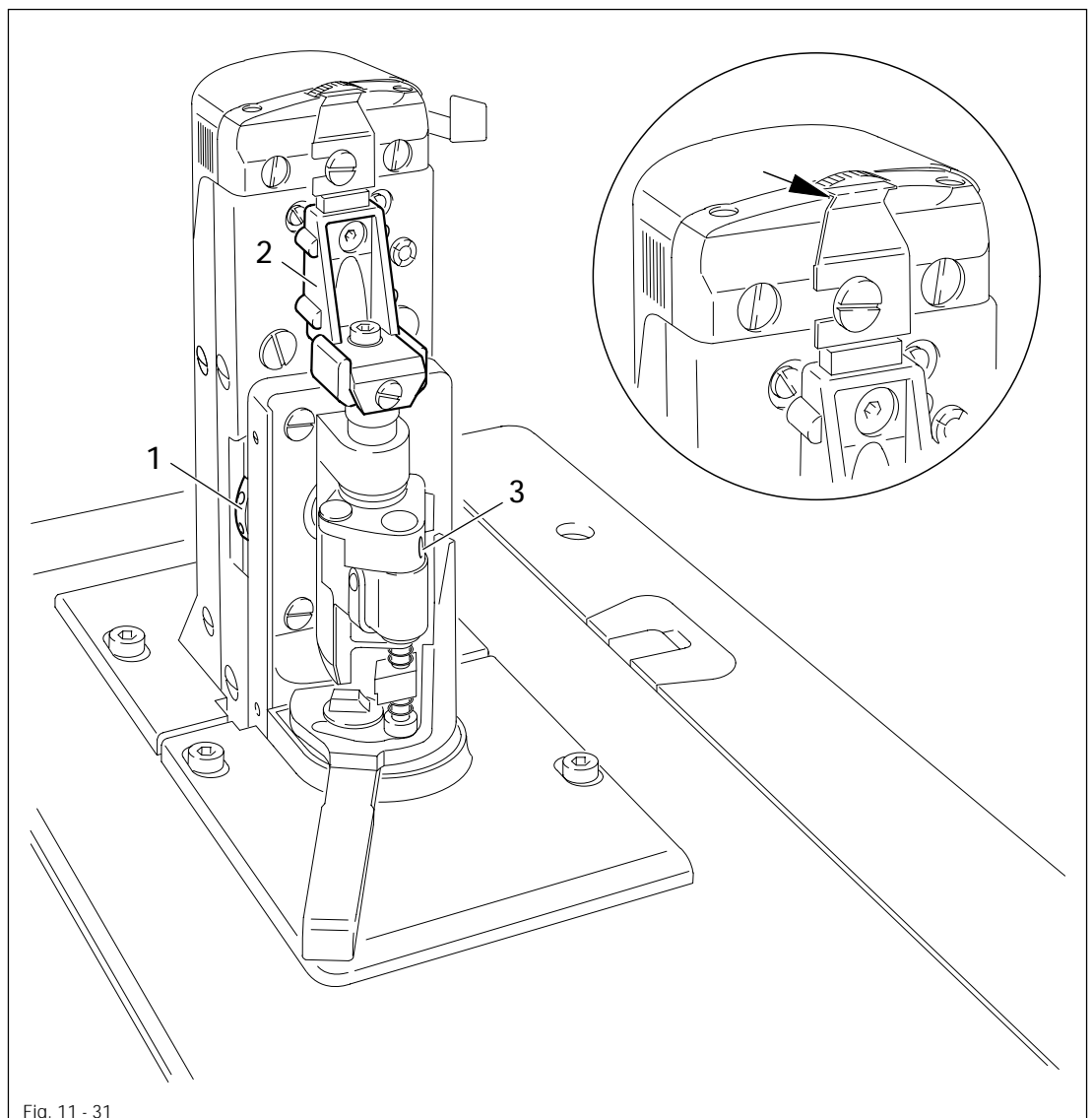

- Turn the adjusting wheel 1 to its highest position and engage edge trimmer.
- Adjust knife holder 2 (screw 3) according to the requirements.

## 11.05.02 Position of the knife holder on models 474 and 491

### Requirement

When the thread trimmer is engaged, the centre of the angular knife opening must be level with the top edge of the needle plate.

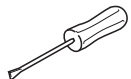
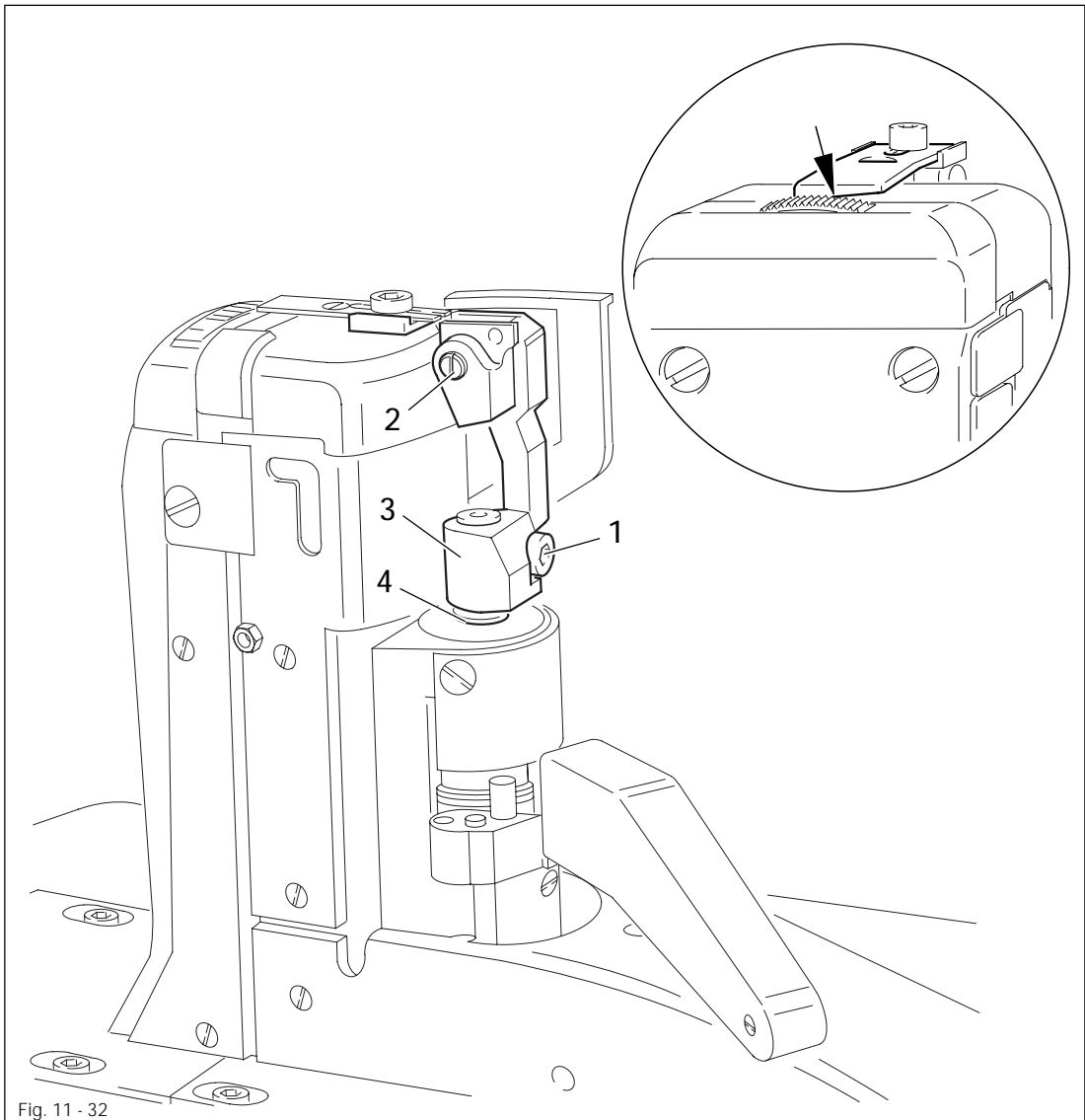

- Switch off the machine and engage the edge trimmer.
- Loosen screw 1.
- By turning eccentric 2, position the knife in the centre of its adjustment range.
- Adjust knife holder 3 according to the **requirement** and tighten screw 1.
- Position locking ring 4 on the knife holder 3.



Depending on the material thickness, changes in the basic setting of eccentric 2 are possible.

## 11.05.03 Knife stroke on model 471

### Requirement

The knife stroke can be adjusted over a range from 1.0 to 3.5 mm, allowing the best possible adaption to all materials used.

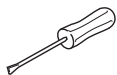
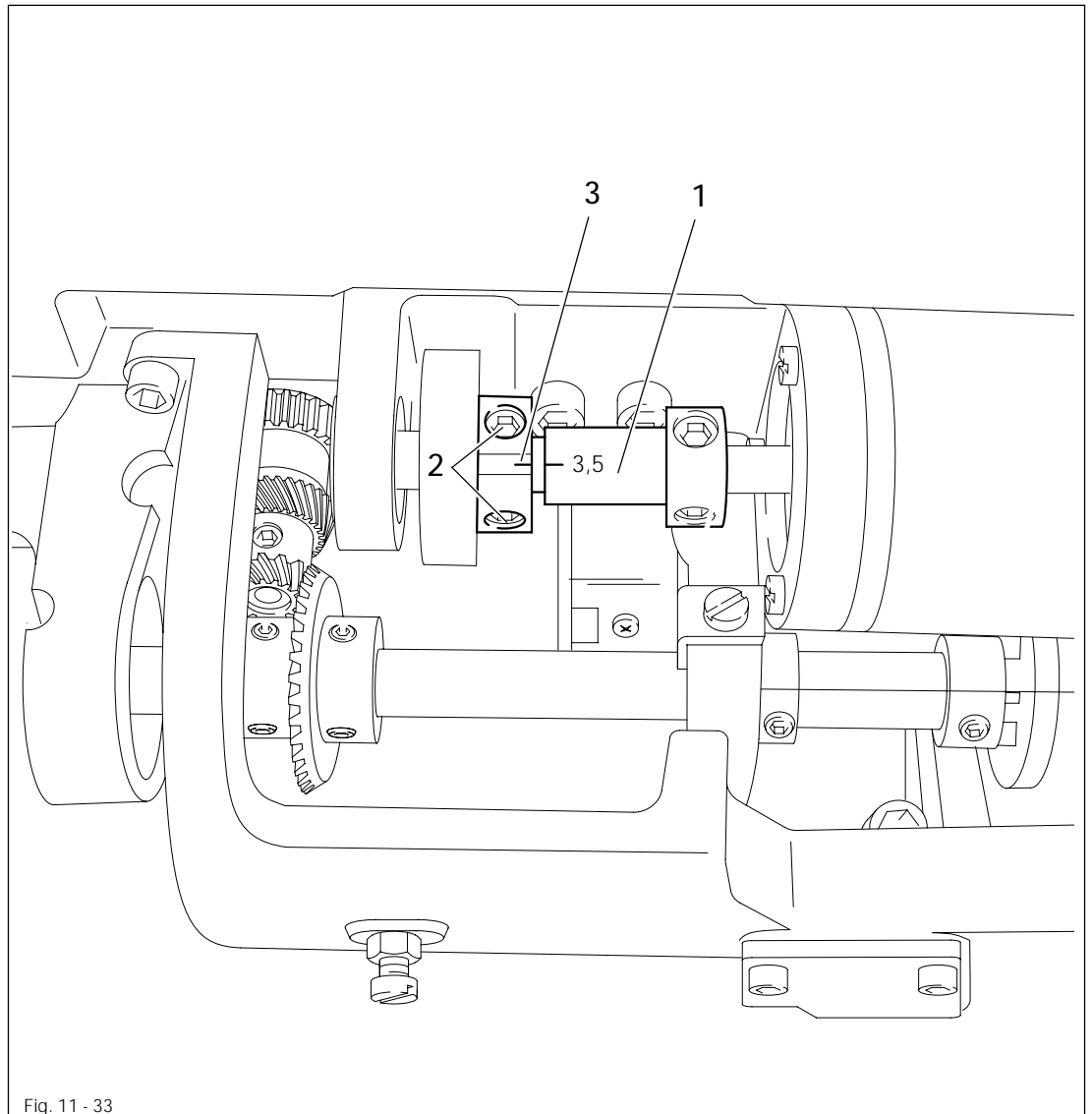

- Turn eccentric 1 (screws 2) so that the marking of the desired cutting stroke is opposite the marking on clamp collar 3.

## Adjustment

### 11.05.04 Knife stroke on models 474 and 491

#### Requirement

The knife stroke can be adjusted over a range from 2.0 to 3.5 mm, allowing the best possible adaption to all materials used.

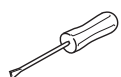
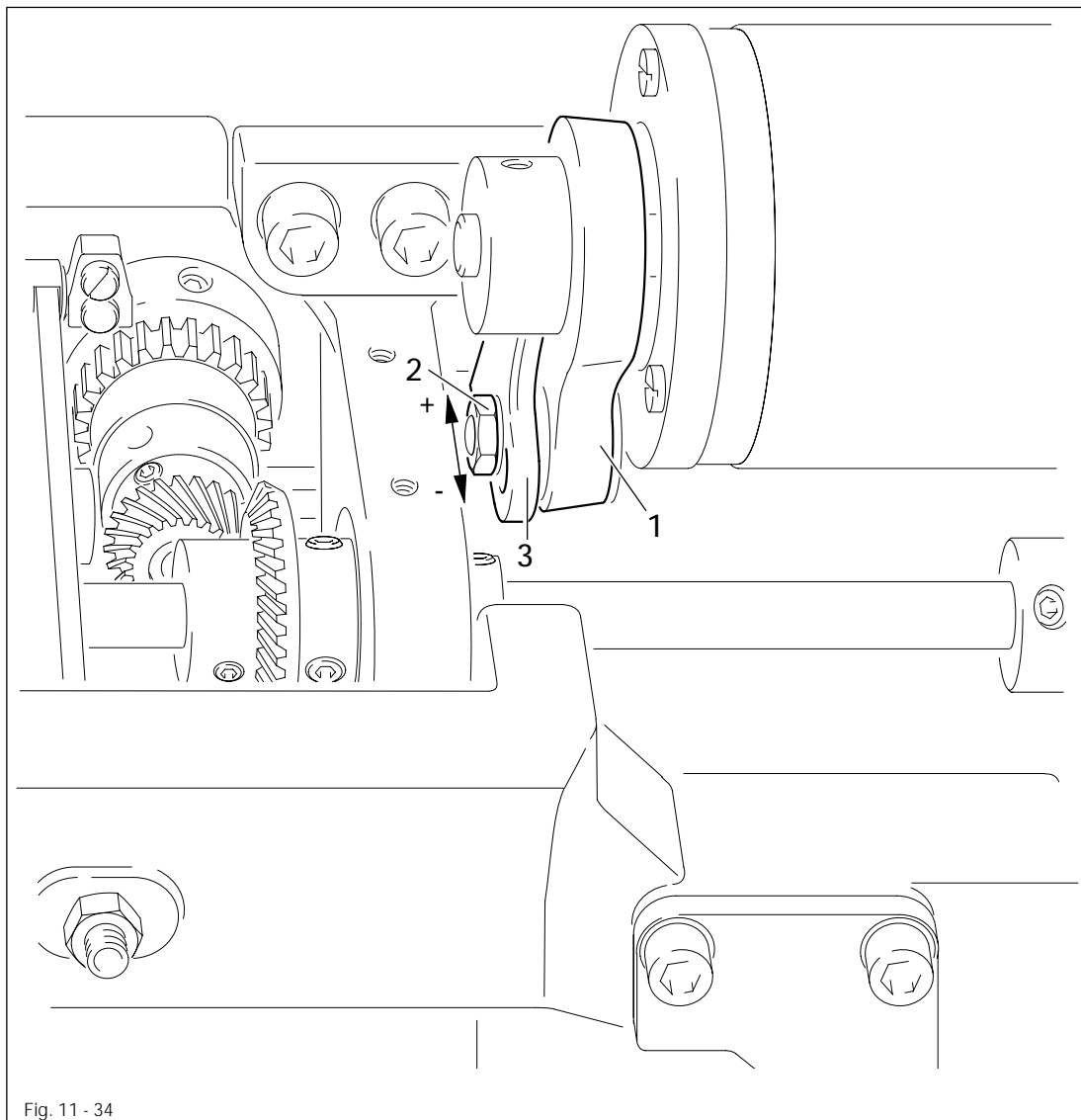

- Adjust crank 1 (nut 2) in slotted lever 3 according to the requirement.

## 11.05.05 Cutting stroke on model 471

**Requirement**

When the edge trimmer is engaged and the needle is in the needle hole, the stroke of knife 1 should be half in front of and half behind the needle, when the motor shaft is turned by hand.

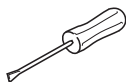
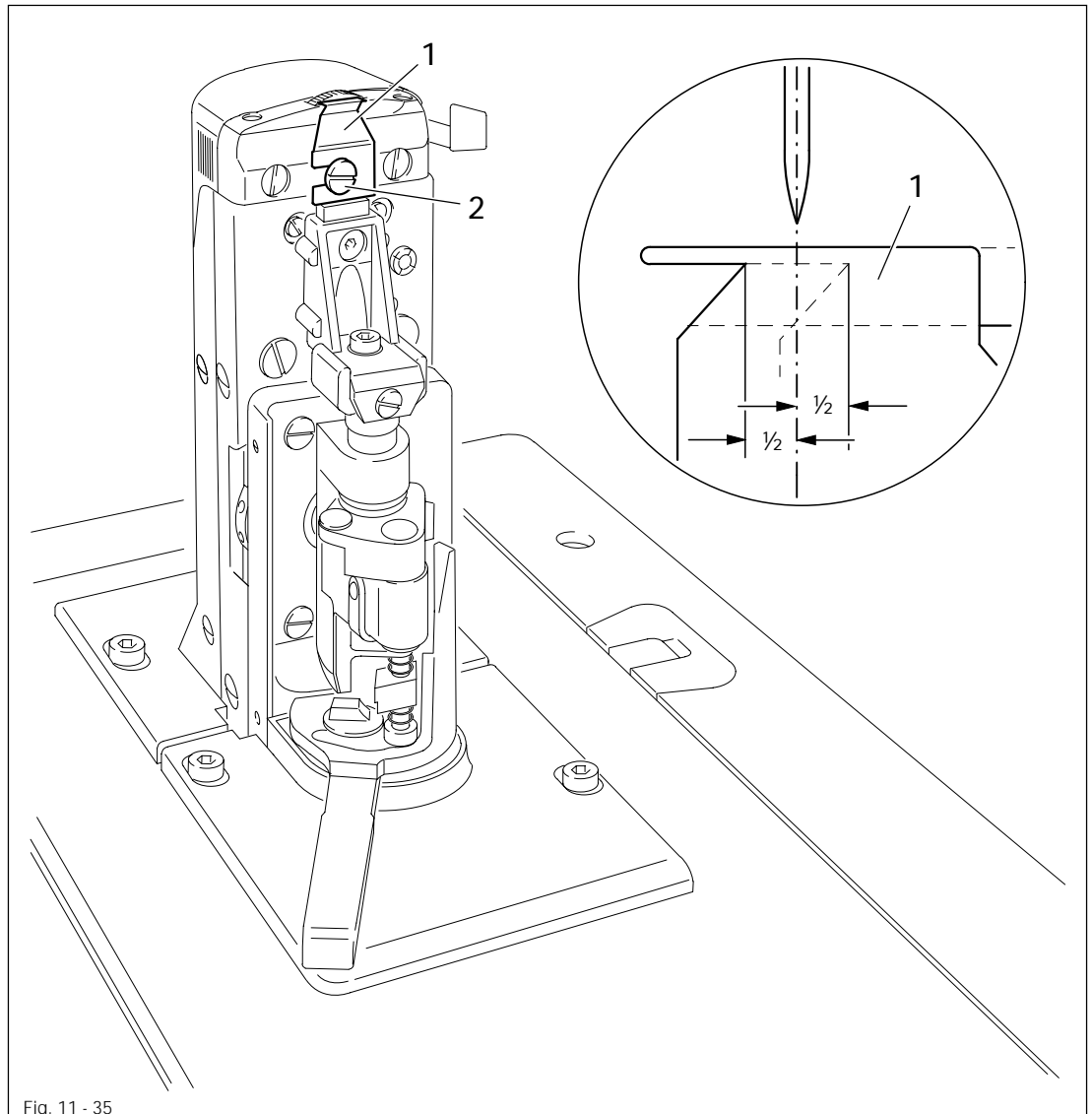

- Switch off the machine and engage the edge trimmer.
- Adjust knife 1 (screw 2) according to the requirement.

## 11.05.06 Cutting stroke on models 474 and 491

### Requirement

When the edge trimmer is engaged and the needle is in the needle hole, the stroke of knife 3 should be half in front of and half behind the needle, when the motor shaft is turned by hand.

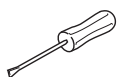
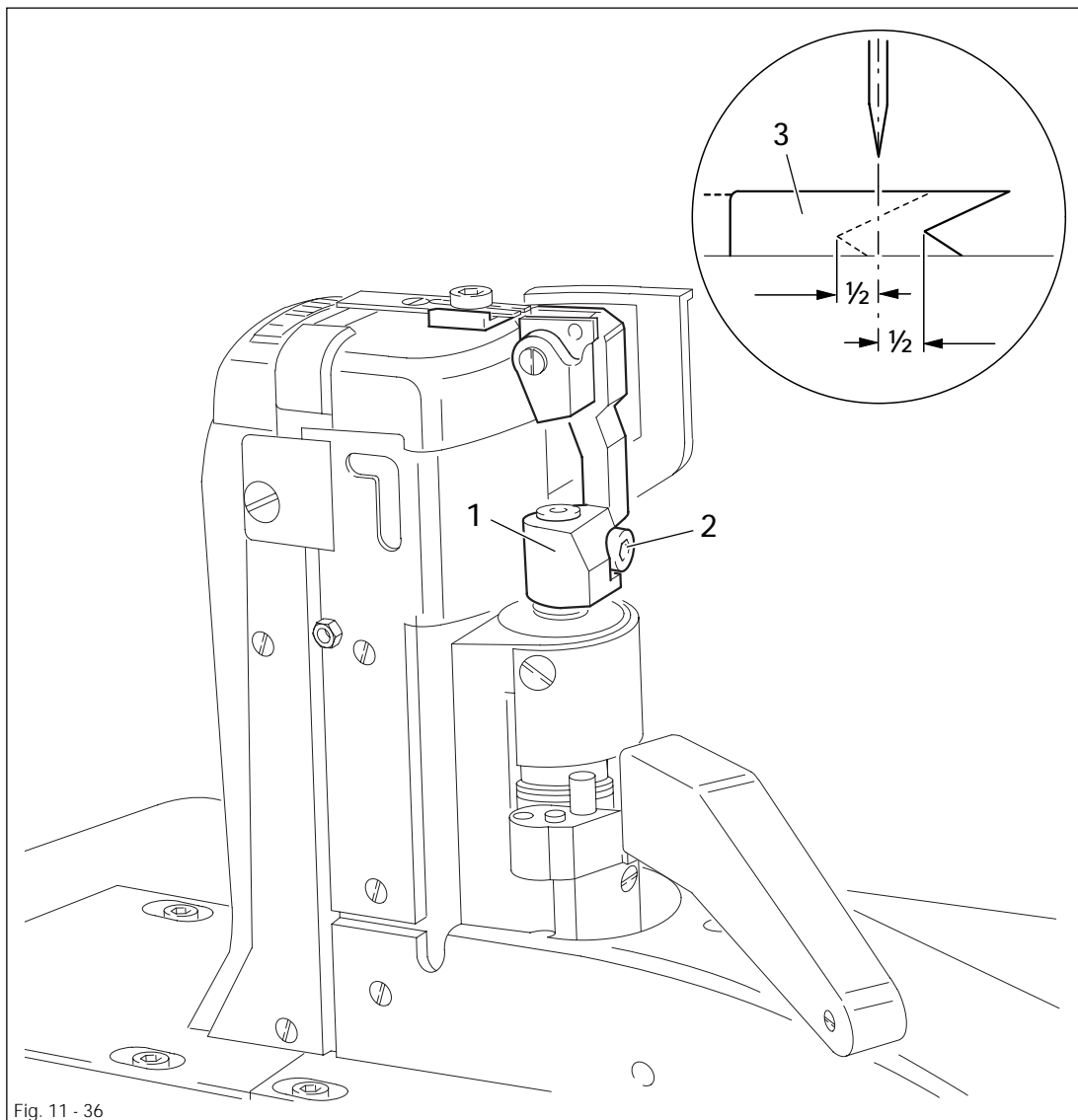

- Switch off the machine and engage the edge trimmer.
- Adjust knife holder 1 (screw 2) according to the requirement.

## 11.05.07 Knife position

### Requirement

When the edge trimmer is engaged, the knife should rest lightly on the needle plate insert, but no whistling sound should occur during trimming.

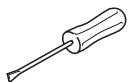
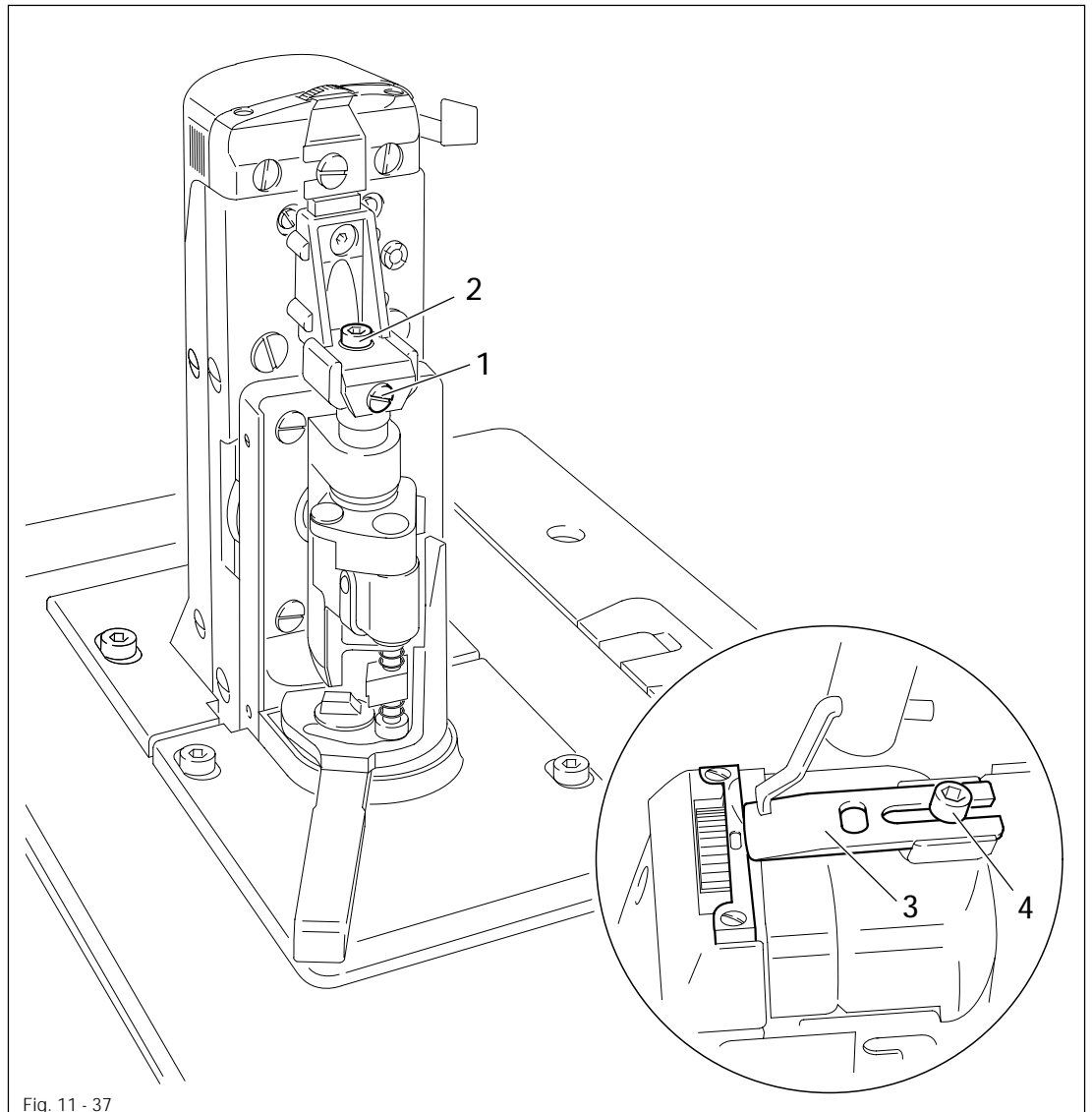

### 471

- Adjust screw 1 (screw 2) according to the requirements.
- Carry out a cutting test and repeat adjustment if necessary.

### 474 and 491

- Adjust knife 3 (screw 4) according to the requirements.
- Carry out a cutting test and repeat adjustment if necessary.

# Adjustment

## 11.06 Adjusting the thread trimmer -726/05 on model 491

### 11.06.01 Position of the knife to the needle plate

#### Requirement

When the edge trimmer is engaged, the knife 2 must be parallel to the needle plate insert.

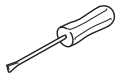
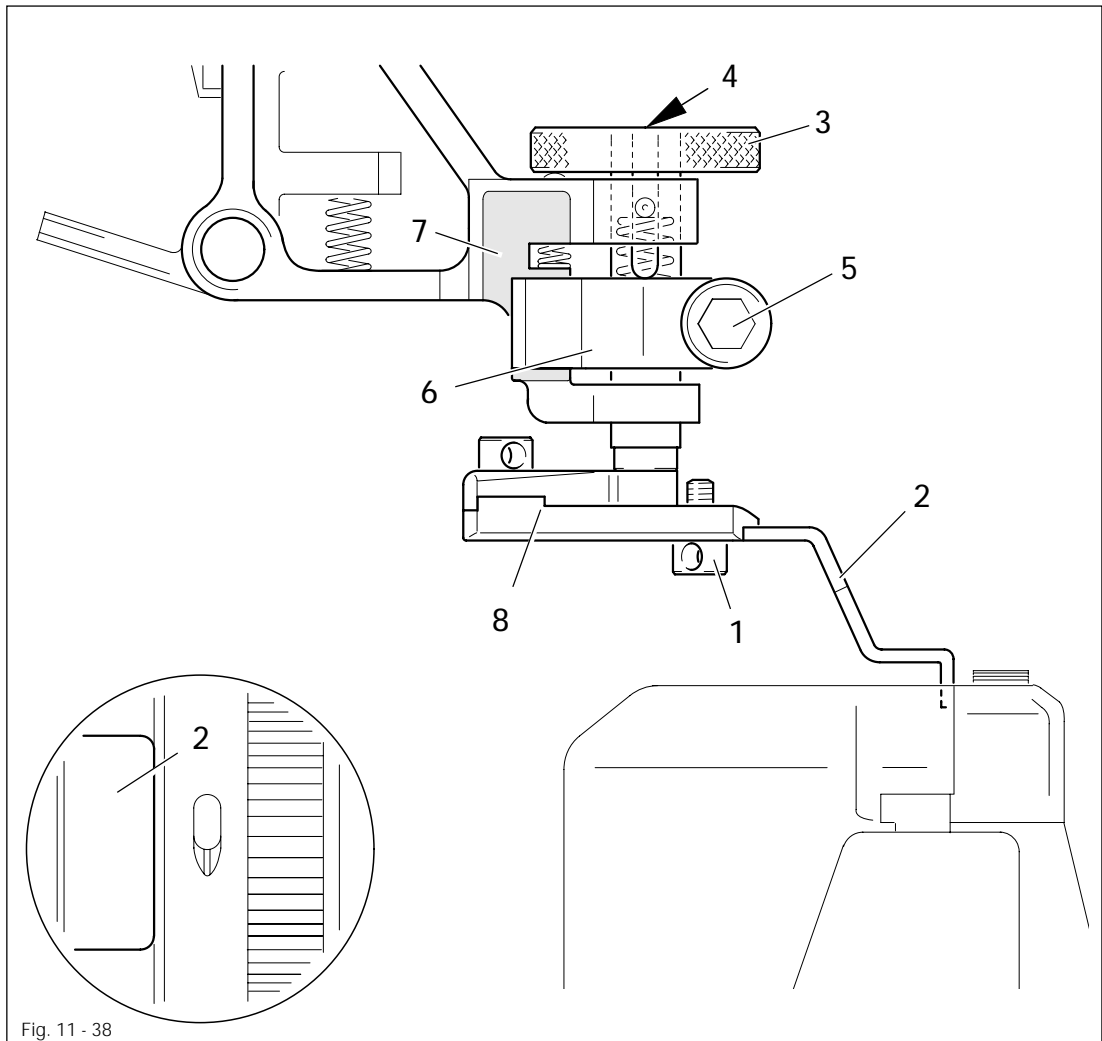

- Switch off the machine and engage the edge trimmer.
- Loosen screw 1 and push back knife 2 slightly.
- Turn milled screw 3 until its top edge is flush with the top edge of the cylindrical guide 4.
- Loosen screw 5, position guide 6 in the centre of guide 7 and slightly tighten screw 5.
- Adjust knife holder 8 according to the **requirement** and tighten screw 5.



Screw 1 remains loosened for further adjustments.



## 11.06.02 Knife position crosswise to sewing direction

### Requirement

When the edge trimmer is engaged, knife 2 must be vertical and rest lightly on the needle plate insert.

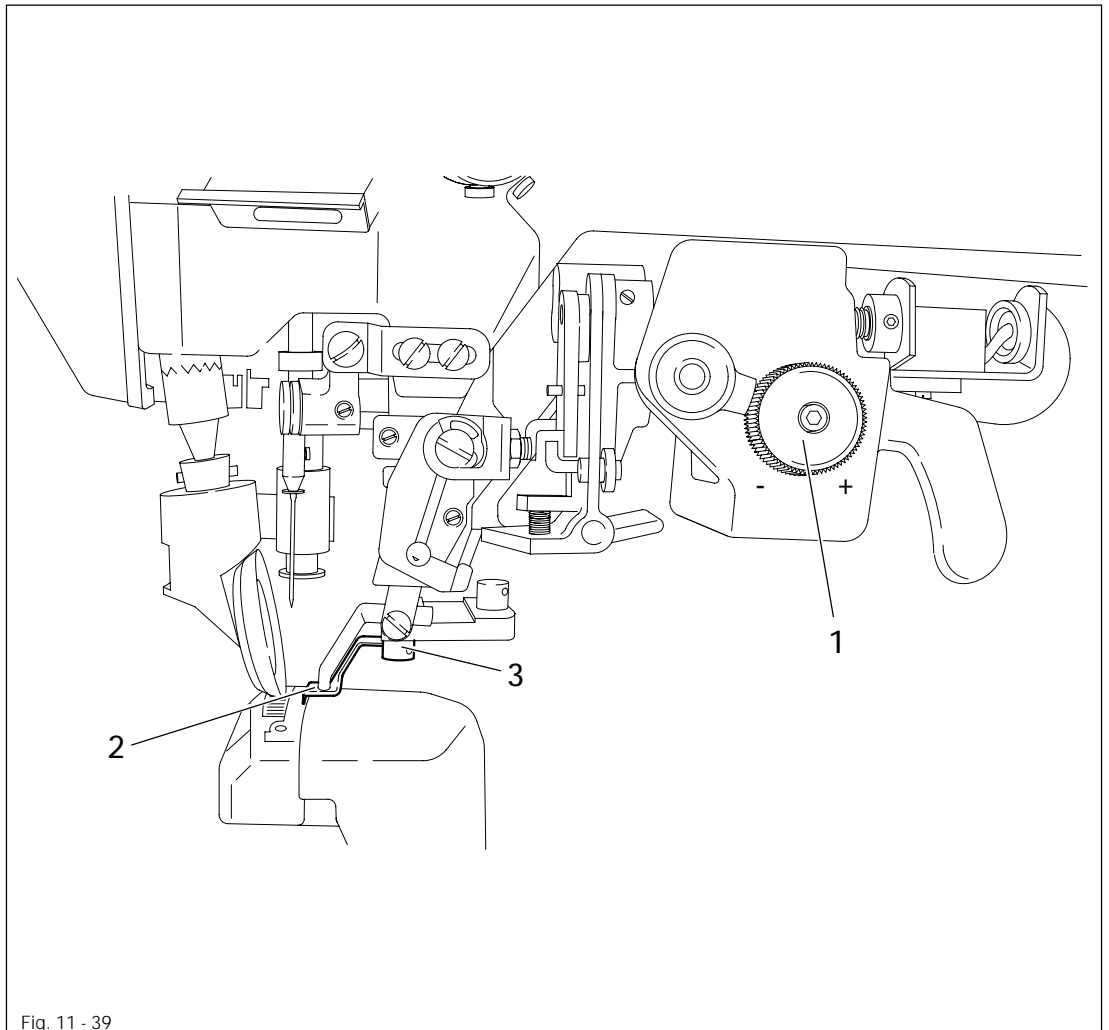
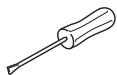

Fig. 11 - 39



- Switch off the machine and engage the edge trimmer.
- Bring the knife into a vertical position by turning milled screw 1.
- Bring knife 2 into light contact with the needle plate insert and tighten screw 3.



The cutting pressure can be adapted to the material used with milled screw 1.

# Adjustment

## 11.06.03 Knife height

### Requirement

When the edge trimmer is engaged, the centre of the angular knife opening must be at the same height as the upper edge of the needle plate.

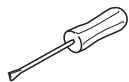
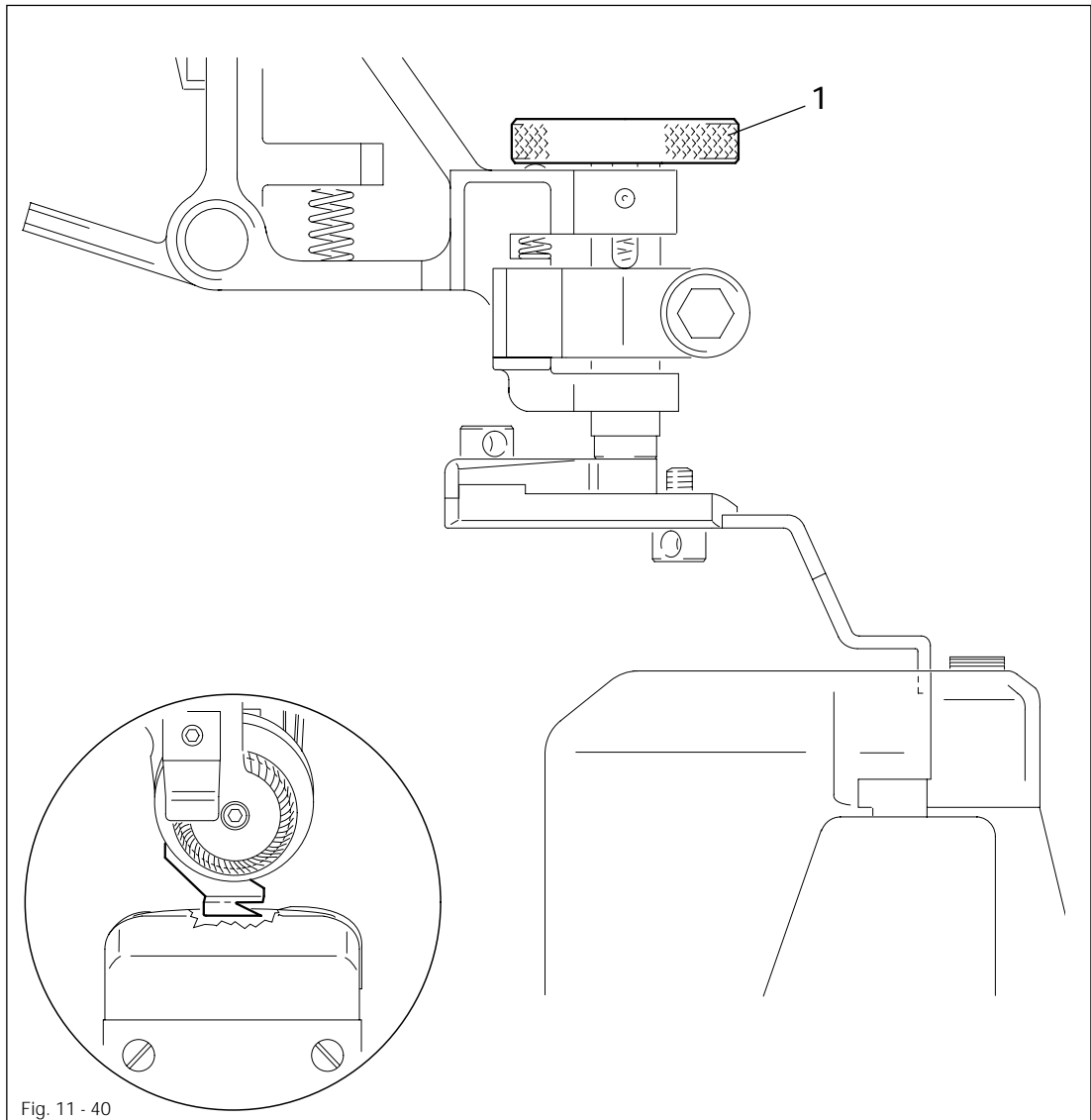

- Switch off the machine and engage the edge trimmer.
- Adjust milled screw 1 according to the **requirement**.



The basic setting may be changed depending on the material thickness.

## 11.06.04 Cutting stroke

### Requirement

When the edge trimmer is engaged and the needle is in the needle hole, the stroke of knife 3 should be half in front of and half behind the needle, when the motor shaft is turned by hand.

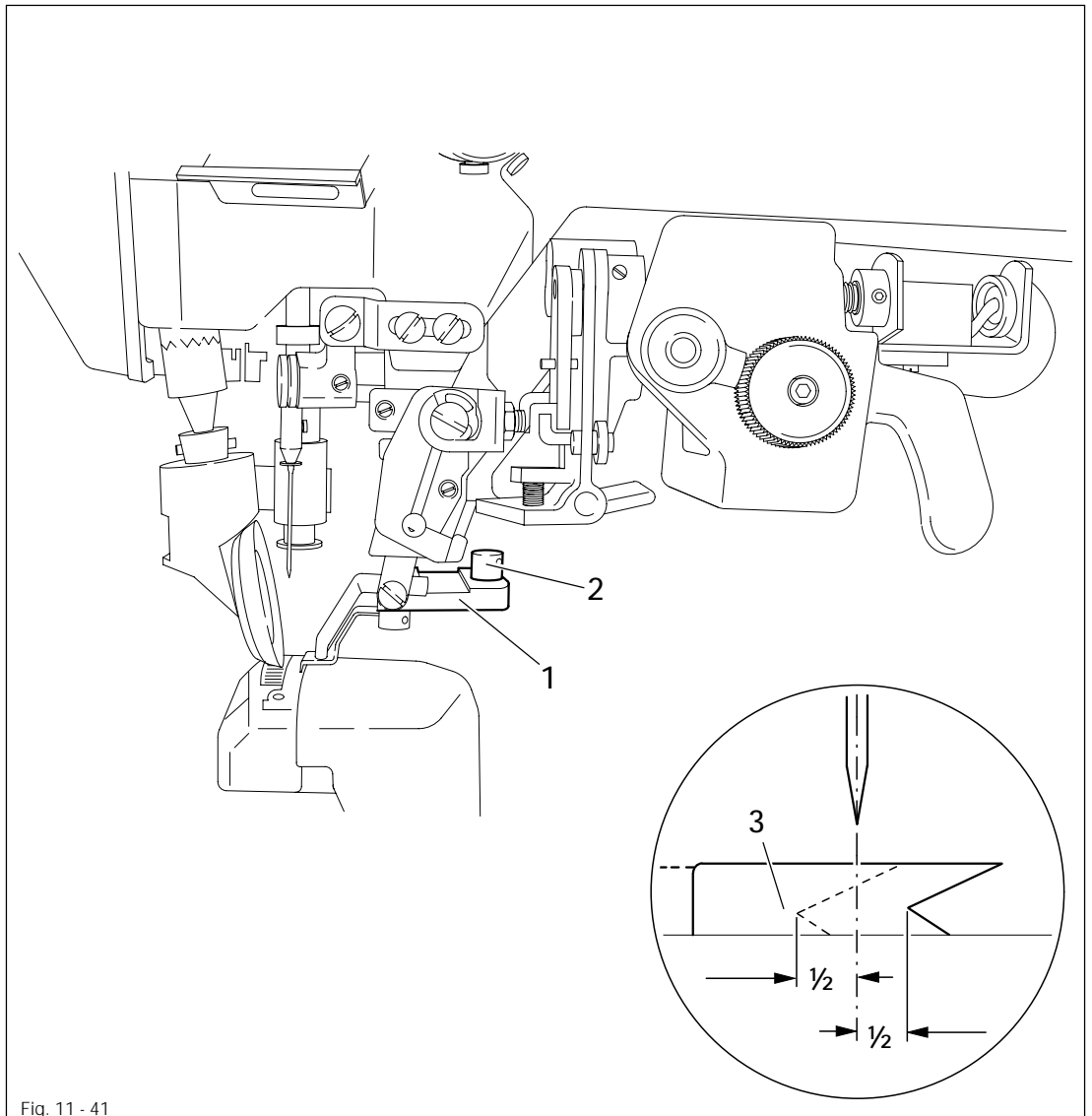
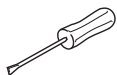

Fig. 11 - 41



- Switch off the machine and engage the edge trimmer.
- Adjust knife holder 1 (screw 2) according to the requirement.

# Adjustment

## 11.06.05 Knife stroke

### Requirement

The knife stroke can be adjusted over a range from 1.0 to 3.5 mm, allowing the best possible adaption to all materials used.

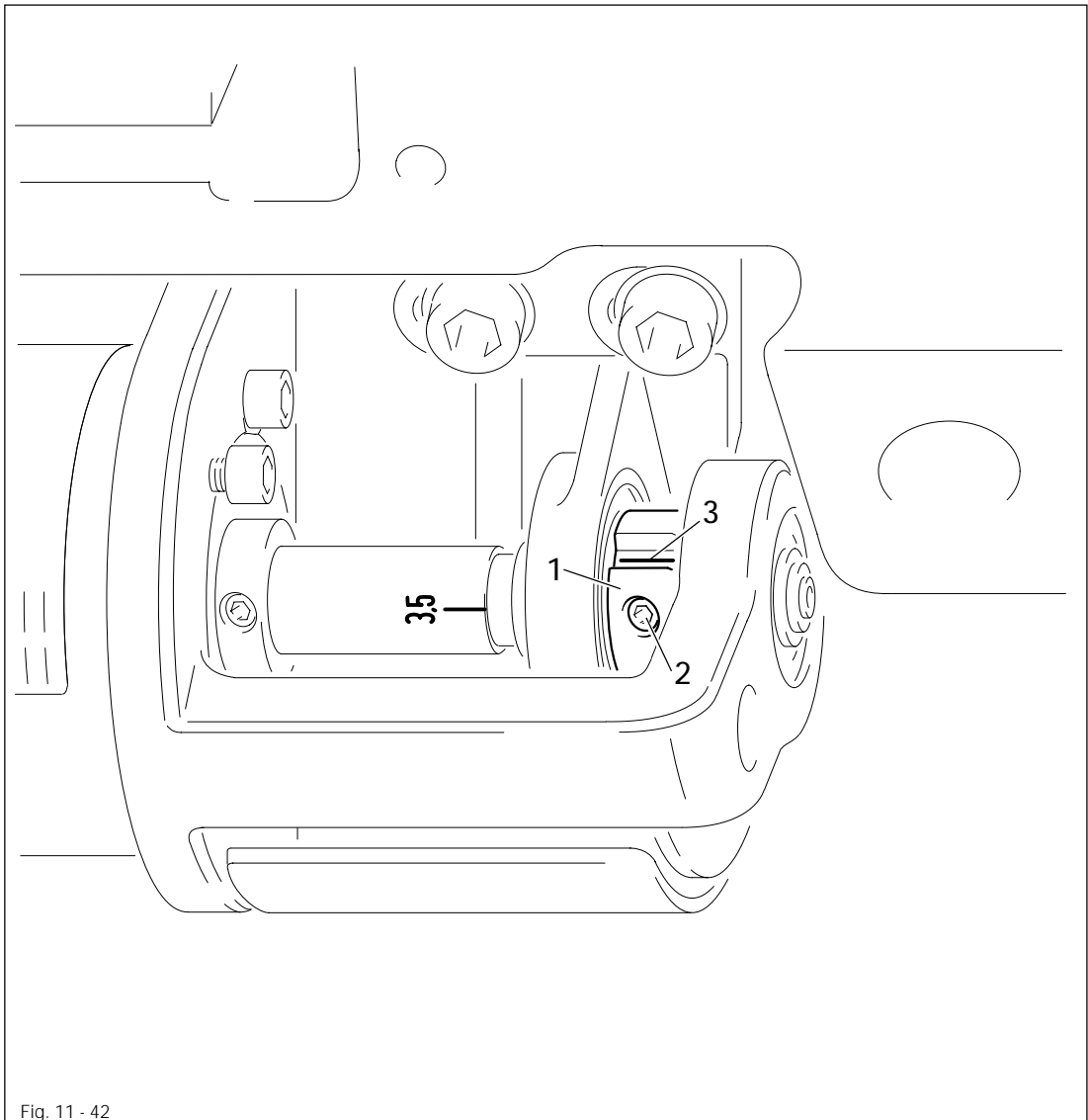
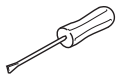

Fig. 11 - 42



- Turn eccentric 1 (screws 2) on the back of the sewing head so that the marking of the desired cutting stroke is opposite marking 3.

## 11.07 Adjusting the thread trimmer -900/53

### 11.07.01 Removing the cutter

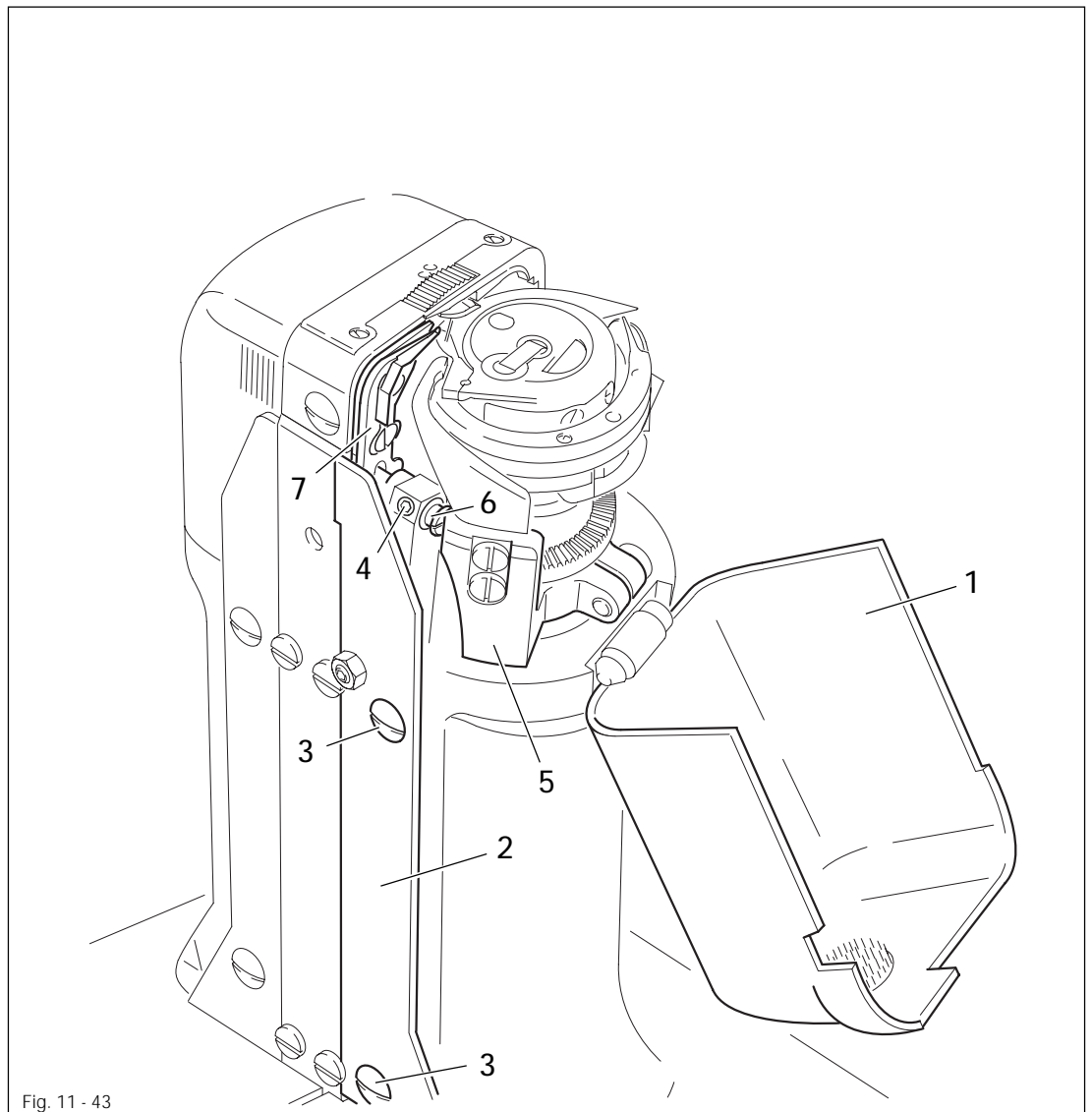
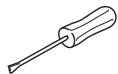

Fig. 11 - 43



- Open post cover 1 and unscrew post cover plate 2 ( screws 3 ).
- Loosen screw 4.
- Swing out bobbin case base 5 by hand and hold it in this position.
- Remove bolt 6.
- Swing out the cutter driving rod and remove cutter 7.
- Allow bobbin case base 5 to swing in and push in the driving rod of the cutter.



Post cover plate 2 remains dismantled for further adjustments.

## 11.07.02 Control cam with respect to bobbin opener and tripping lever

### Requirement

1. Control cam 2 must be touching bearing collar 3.
2. The roller of tripping lever 6 must fall slightly into the path of control cam 2.

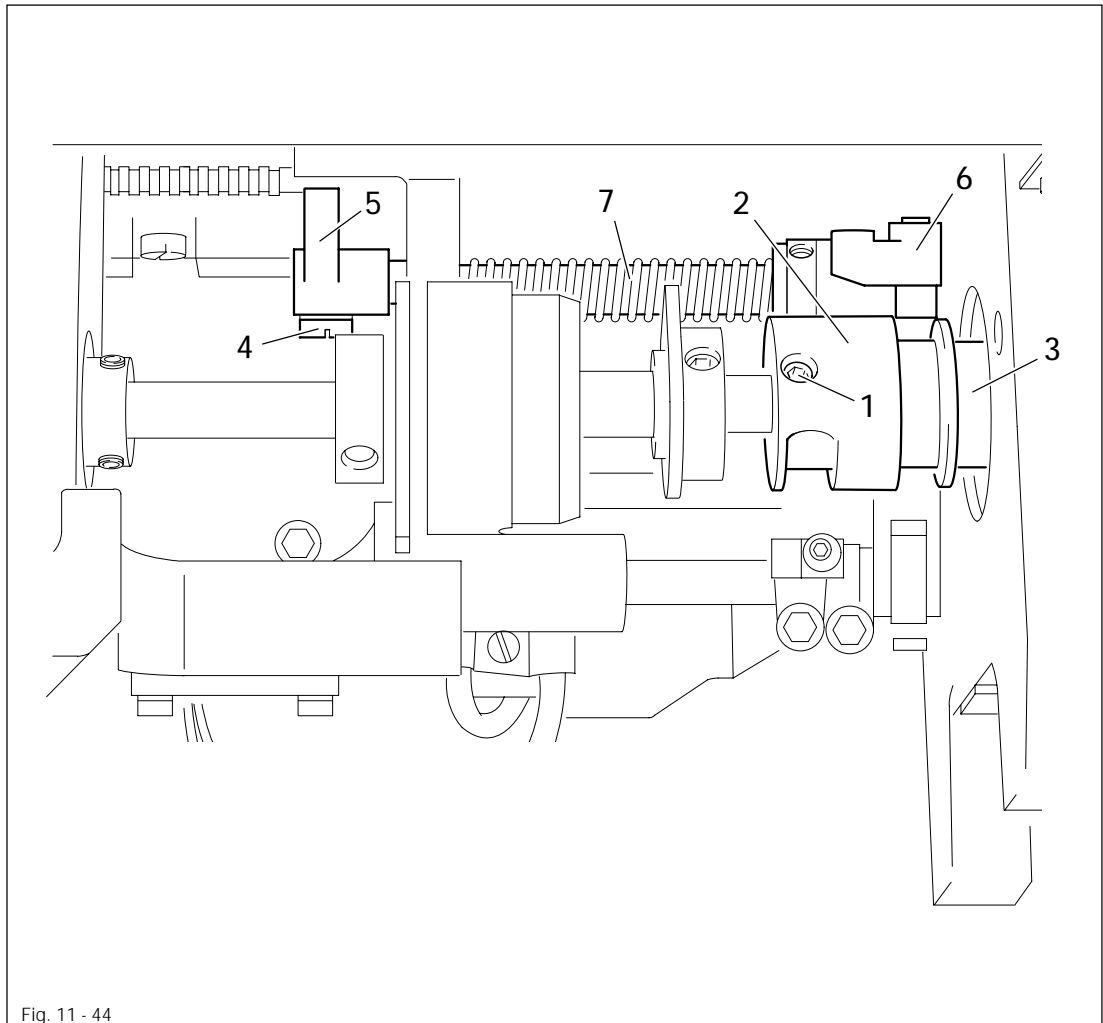
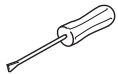

Fig. 11 - 44



- Loosen screws 1 and bring control cam 2 to rest against bearing collar 3.
- In this position tighten one of the screws 1 slightly so that control cam 2 can still be turned.
- Loosen screw 4.
- Position the straight section of the control cam underneath the roller of the tripping lever 6.
- Move tripping lever 6 together with shaft 7 in accordance with **requirement 2**.
- Taking care to ensure that connecting link 5 engages completely in the groove of the rack, bring connecting link 5 to rest on the right and tighten screw 4.



Only tighten screws 1 slightly for the following adjustment.

## 11.07.03 Radial position of the tripping lever

### Requirement

With the tripping lever 3 in resting position, there must be a clearance of **0.3 mm** between its roller and the circumference of the control cam 4.

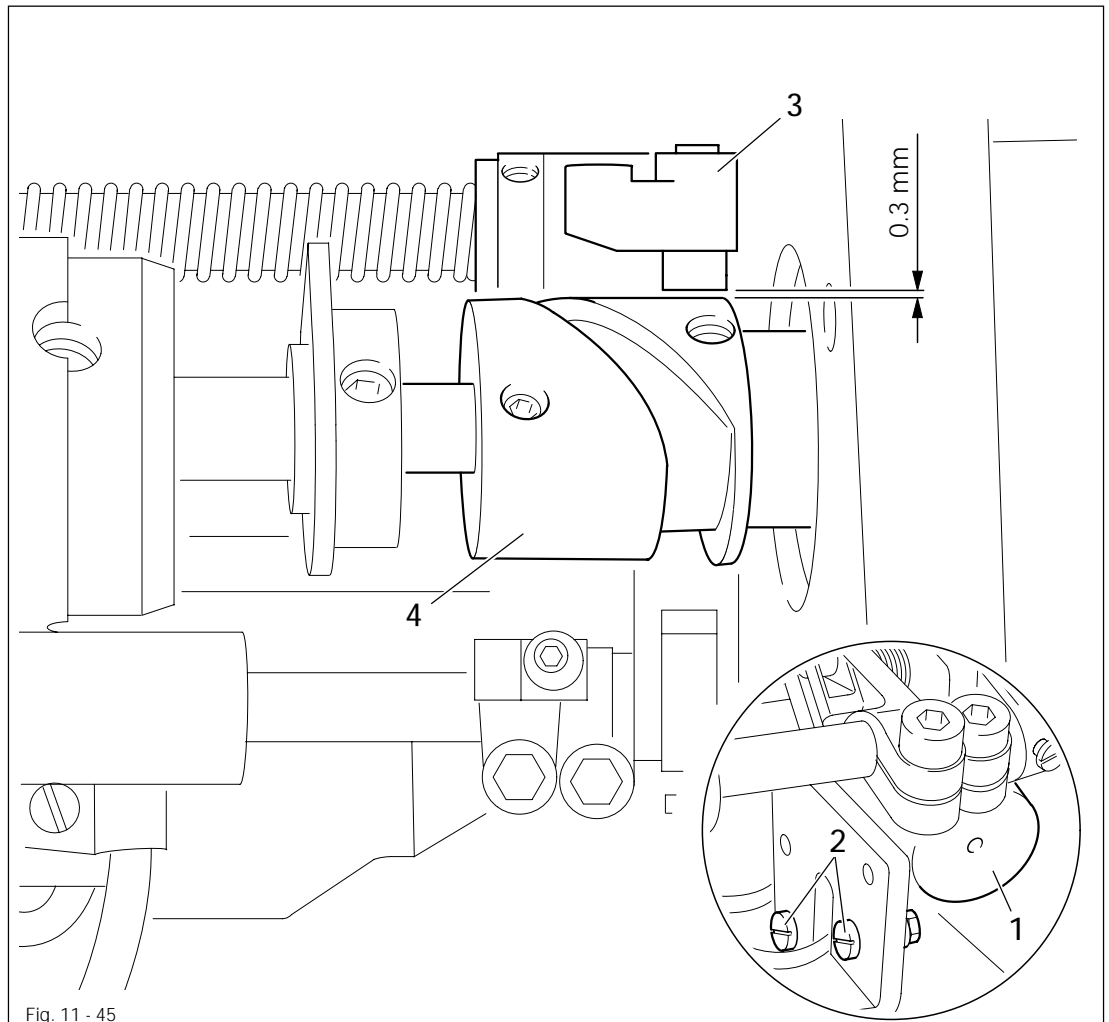
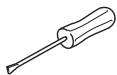

Fig. 11 - 45



- Move solenoid carrier 1 (nuts of screws 2) in accordance with the requirement.

## Adjustment

### 11.07.04 Engaging solenoid

#### Requirement

With the thread trimmer switched on, the magnet core must still be positioned at a distance of 1 mm before its lower stop.

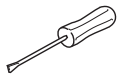
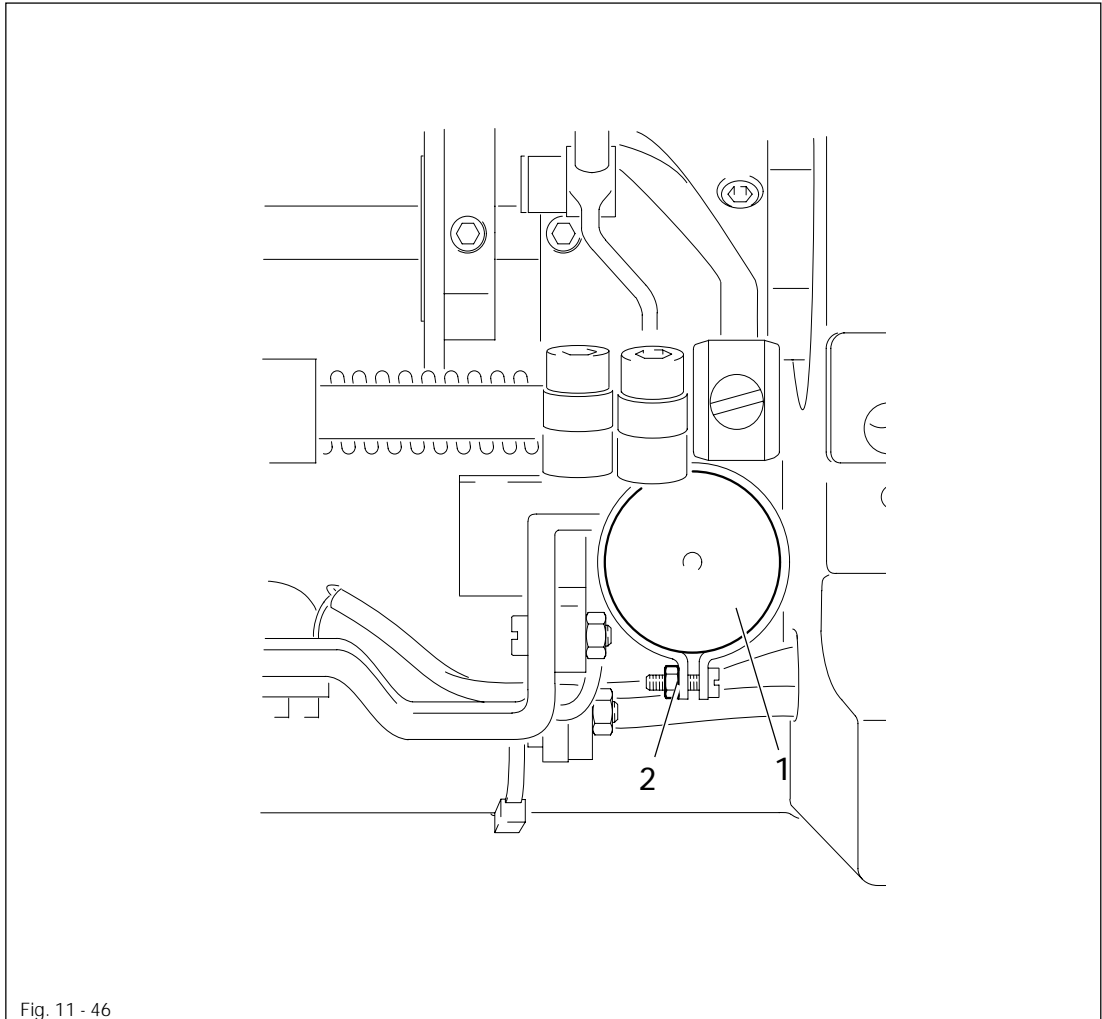

- Bring the needle bar to BDC and activate the tripping lever by hand.
- Push solenoid housing 1 (screw 2) up as far as possible and then move it in accordance with the requirement.
- Lift the tripping lever out of the control cam by hand.



## 11.07.05 Cutter drive lever

**Requirements****471 and 474**

When the thread trimmer is in its resting position, the distance between cutter drive lever 4 and the bearing collar of the lever 5 must be approx. 0.5 mm.

**491**

The top edge of screw 1 must be approx. 9 mm from the recess of the cast case.

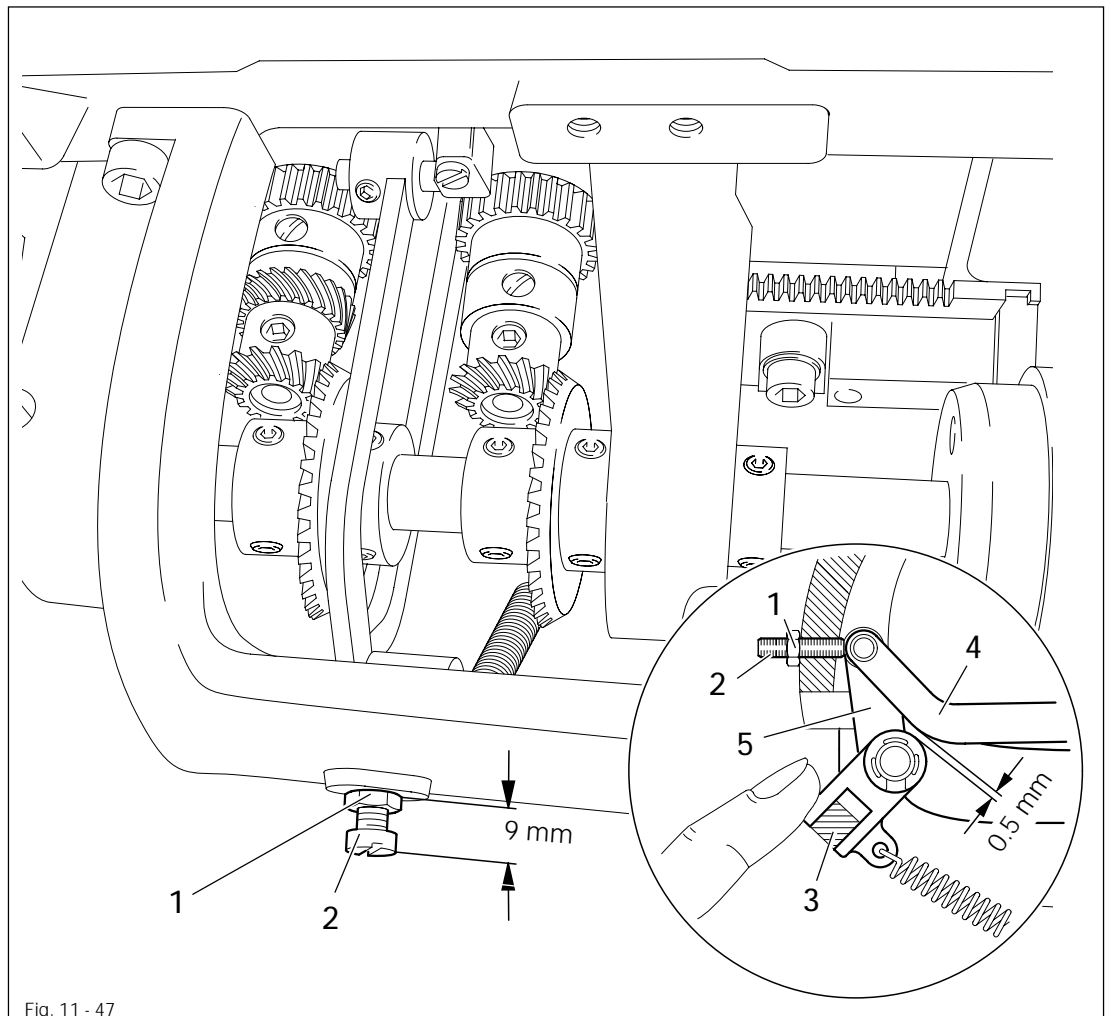
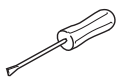

Fig. 11 - 47

**471 and 474**

- Loosen nut 1 and screw out screw 2 a few times.
- Press lever 3 and screw in screw 2 by hand until a marked resistance is felt, during which action lever 3 must not be raised.
- Screw in screw 2 half a turn more and tighten nut 1.

**491**

- Adjust screw 1 (nut 2) according to the requirement.

## 11.07.06 Control cams for bobbin opener and cutter (using adjustment gauge)

### Requirement

With the needle bar at BDC, both control cams must be positioned in such a way that

1. adjustment gauge 5 can be slid into the grooves of both control cams,
2. both cams are on the rests of adjustment gauge 5 and
3. the bent section of adjustment gauge 5 is touching roller 3.

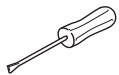
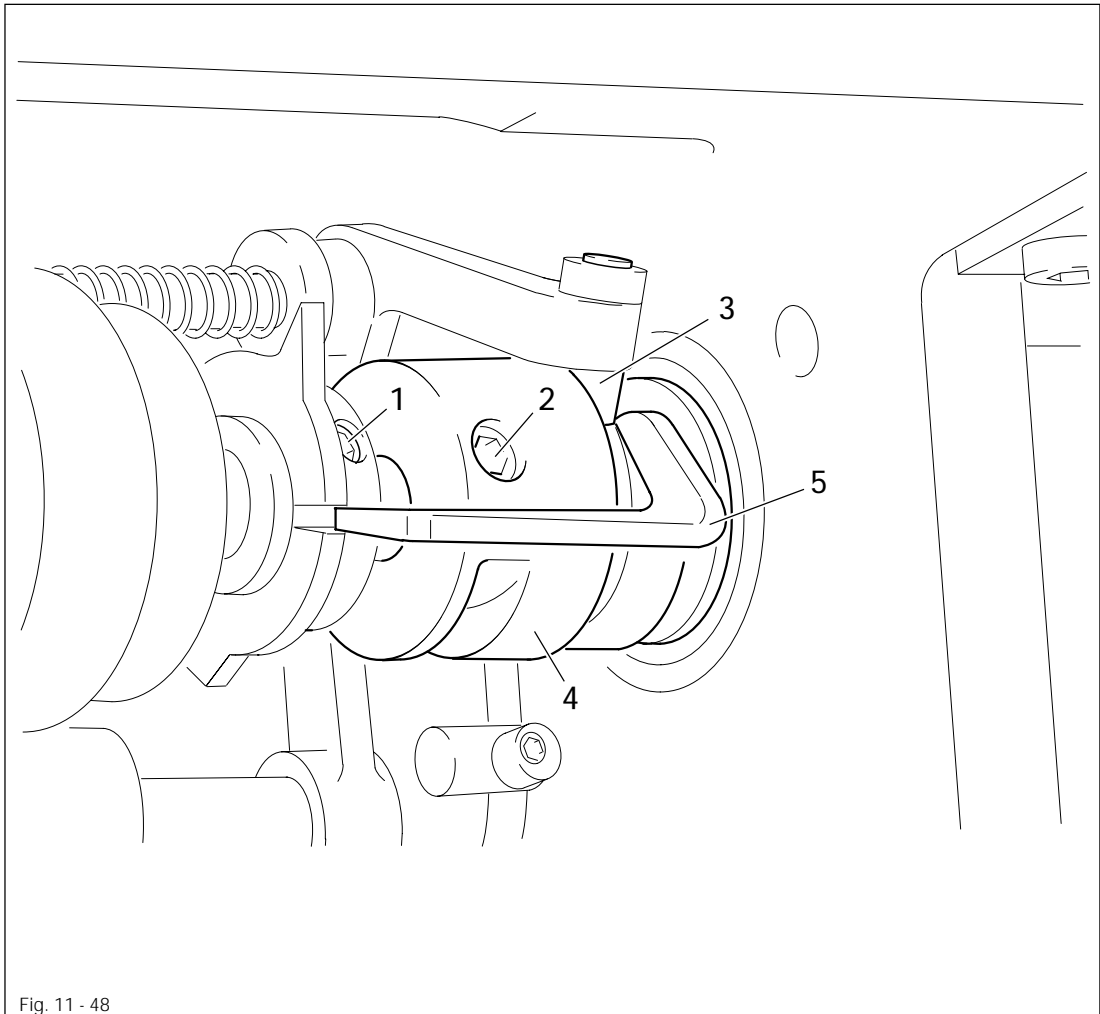

- Loosen screws 1 and 2.
- Bring the needle bar to BDC and activate the tripping lever by hand (roller 3 engaged).
- Adjust the control cams in accordance with the **requirement** and insert adjustment gauge 5.
- Turn control cam 4 in accordance with the **requirement**.
- Taking care to ensure that control cam 4 is touching the bearing collar, tighten the accessible screws 1 and 2.
- Remove adjustment gauge 5 and tighten the remaining screws 1 and 2.



For adjustment without the gauge see chapter 11.07.07 Radial position of the control cam in relation to the bobbin opener and chapter 11.07.09 Cutter control lever for control cam of cutter.

## 11.07.07 Radial position of the control cam in relation to the bobbin opener (adjustment without gauge)

### Requirement

The retracting motion of the bobbin opener must begin when the needle bar is 4 mm after BDC.

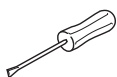
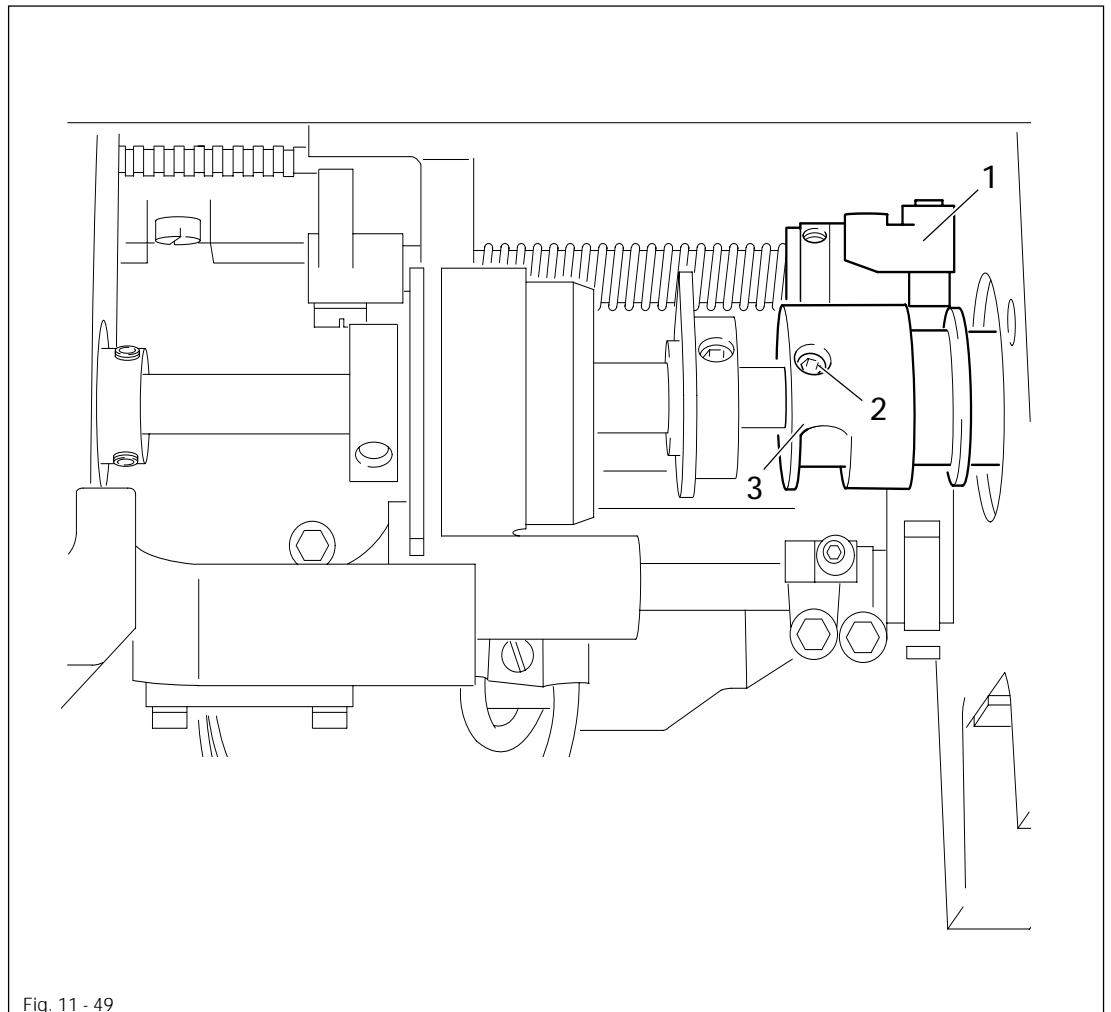

- Activate the tripping lever by hand. The roller of the tripping lever 1 must fall easily and unobstructed in to the cam track.
- Loosen screws 2.
- Bring the needle bar to 4 mm after BDC ( use adjustment gauge and C-clamp ).
- Turn control cam 3 in the direction of rotation until you feel resistance ( start of the retracting motion ).
- In this position tighten the accessible screw 2.
- Remove tripping lever 1 out of the control cam 3 by hand.
- Remove the C-clamp and tighten the remaining screw 2.

## 11.07.08 Control cam for cutter (adjustment without gauge)

### Requirements

1. The cutting movement must begin when the needle bar is positioned 0.6 mm past TDC.
2. There must be a distance of **9 mm** between control cams 2 and 4.

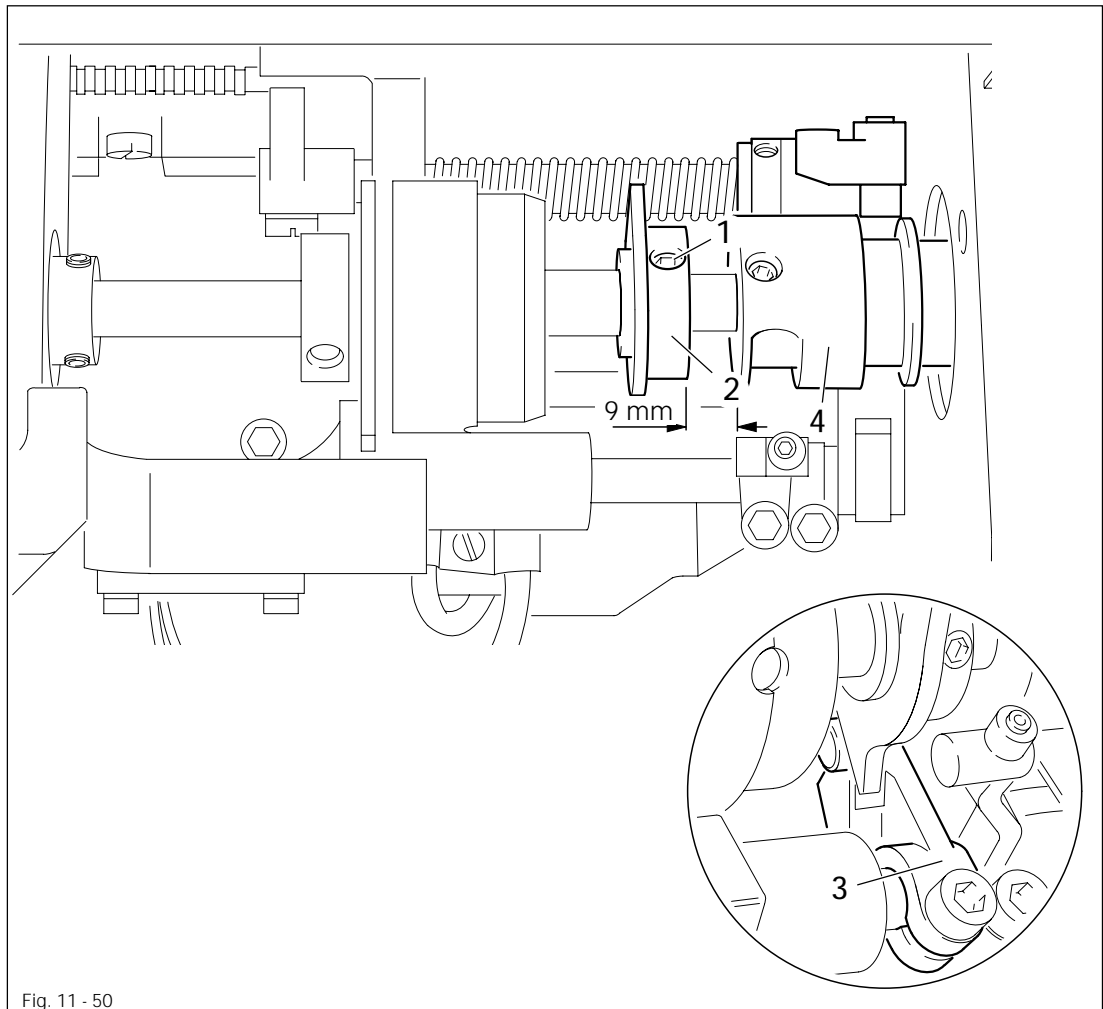
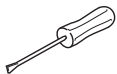

Fig. 11 - 50



- Loosen screws 1.
- Bring needle bar to BDC and operate the engaging lever by hand.
- Bring the needle bar to 0.6 mm past TDC (use adjustment gauge and clamp).
- Turn control cam 2 until the cam is resting on the cylinder of control lever 3.
- Making sure that control cam 2 is at a distance of **9 mm** to sliding cam 4, tighten one of the screws 1.
- Remove clamp, make second screw 1 accessible and tighten it.



When using elastic thread it may be necessary to adjust the control cams for the bobbin opener and cutter a little "later".

For very elastic threads a thread tension control device (subclass 906/10) for automatic tension release is available.

## 11.07.09 Cutter control lever for the control cam of the cutter

**Requirements**

At the left point of reversal of the rock shaft 3

1. the cylinder of control lever 4 and of reversing lever 5 must be positioned at the centre of the control cam 6;
2. between the cylinder of control lever 4 and the outer diameter of the control cam 6 there must be a distance of 0.3 mm.

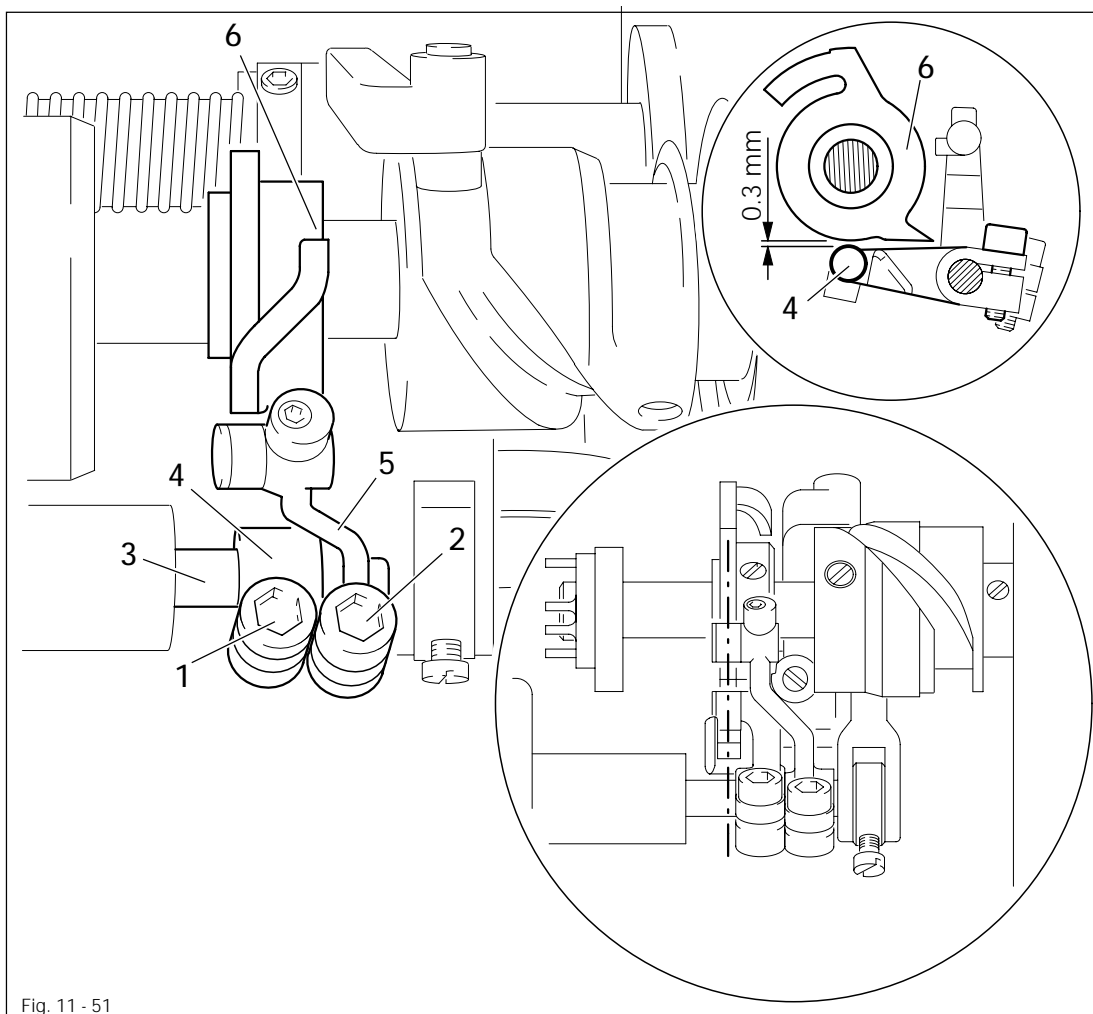
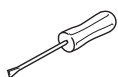

Fig. 11 - 51



- Bring needle bar to BDC and operate engaging lever by hand.
- Loosen screws 1 and 2.
- Turn balance wheel in turning direction, until rock shaft 3 is in its left point of reversal.
- Adjust control lever 4 and reverse lever 5 according to **requirement 1**.
- Turn control lever 4 according to **requirement 2**.
- In this position and taking **requirement 1** into consideration, tighten screw 1.



Screw 2 remains loosened for later adjustments.

## 11.07.10 Cutter return lever

### Requirement

When the roller of tripping lever 3 is exactly at the point of the trip of control cam 2 the maximum distance between the roller of return lever 4 and control cam 2 must be 0.2 mm.

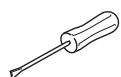
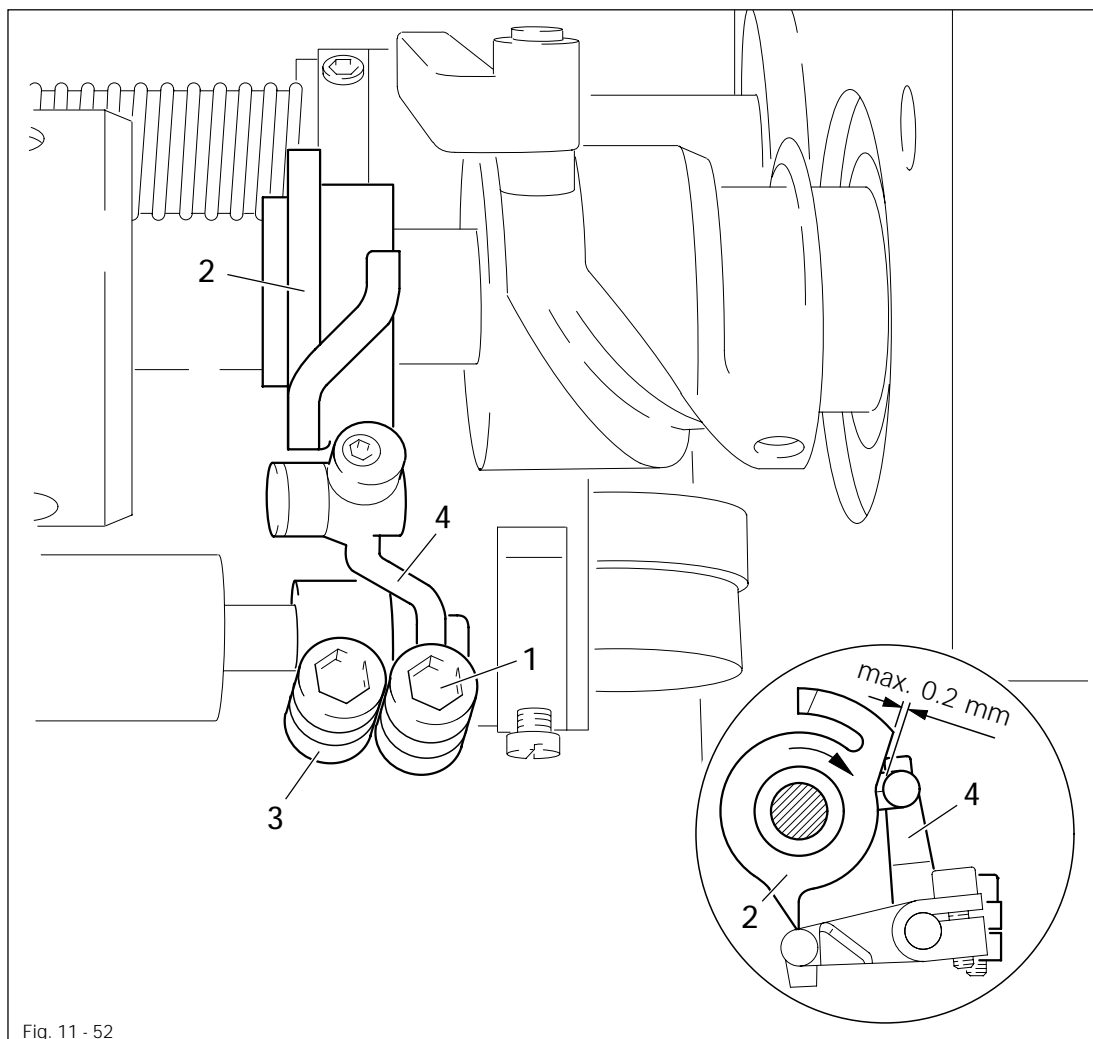

- Bring the needle bar to BDC and activate the engaging lever by hand.
- Position the point of the trip of control cam 2 exactly at the middle of the roller of tripping lever 3 by turning the handwheel in the direction of sewing.
- Maintaining this position, bring the return lever 4 to rest against the side of tripping lever 3 and turn it radially in accordance with the **requirement**.
- Tighten screw 1.

## 11.07.11 Cutter return control

**Requirement**

1. When the point of the trip of control cam 1 is exactly at the roller of tripping lever 2 and trip 3 is touching the beginning of the angular edge of guide plate 5 (see arrow), there must be a clearance of approx. **0.6 mm** between trip 3 and guide plate 5.
2. When the rock shaft has sprung back to its starting position the maximum clearance between trip 3 and guide plate 5 must be **0.3 mm**.

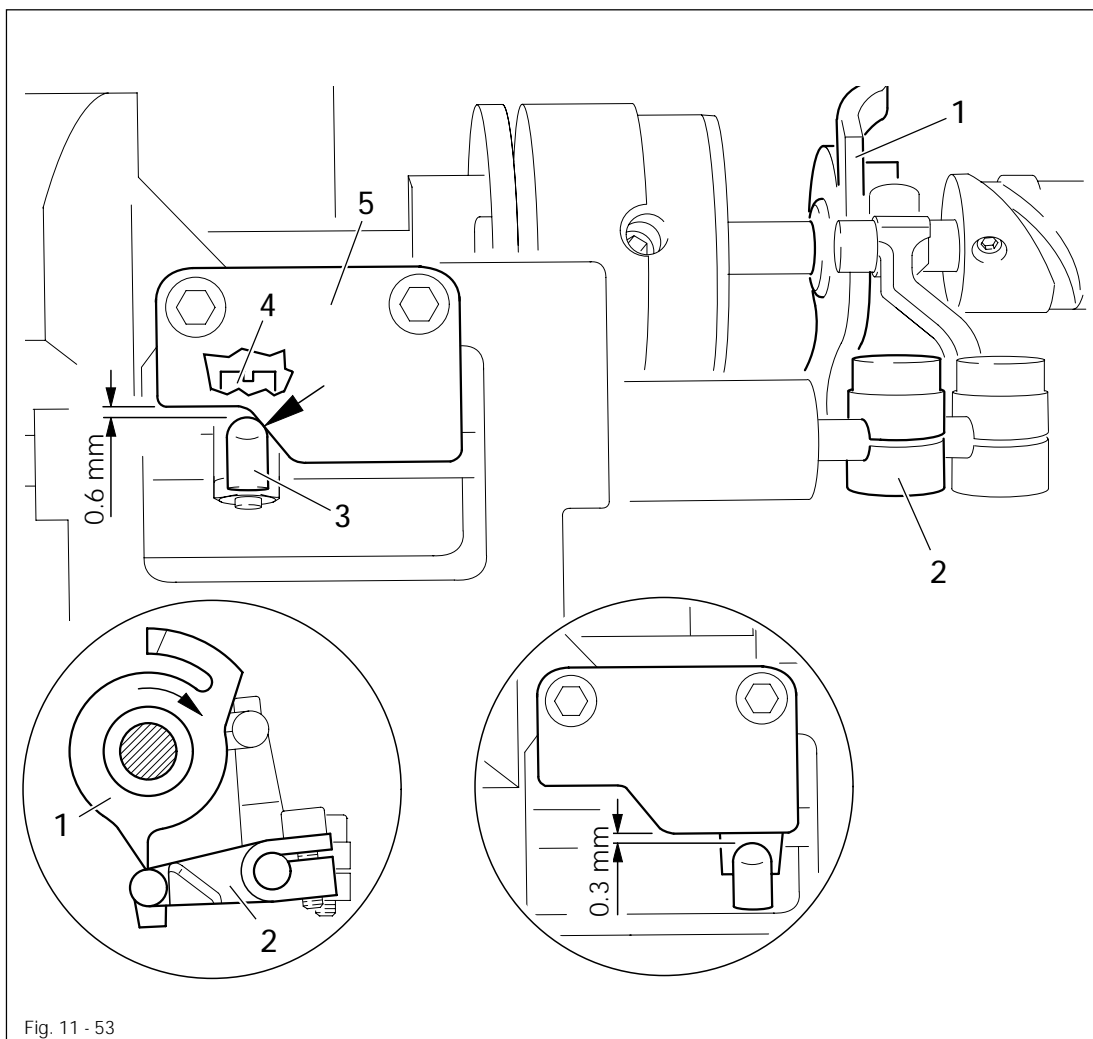
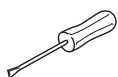

Fig. 11 - 53



- Position the point of the trip of control cam 1 exactly at the roller of tripping lever 2 by turning the handwheel.
- Move trip 3 ( screw 4 ) in accordance with **requirement 1**.
- Bring rock shaft back to its starting position.
- Check **requirement 2**. If necessary, position guide plate 5 appropriately.

## 11.07.12 Fitting the cutter

### Requirement

1. The pin of bolt 4 must protrude into the cam tracks of the cutter halves.
2. The cutter must work with as little lateral play as possible.

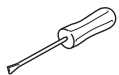
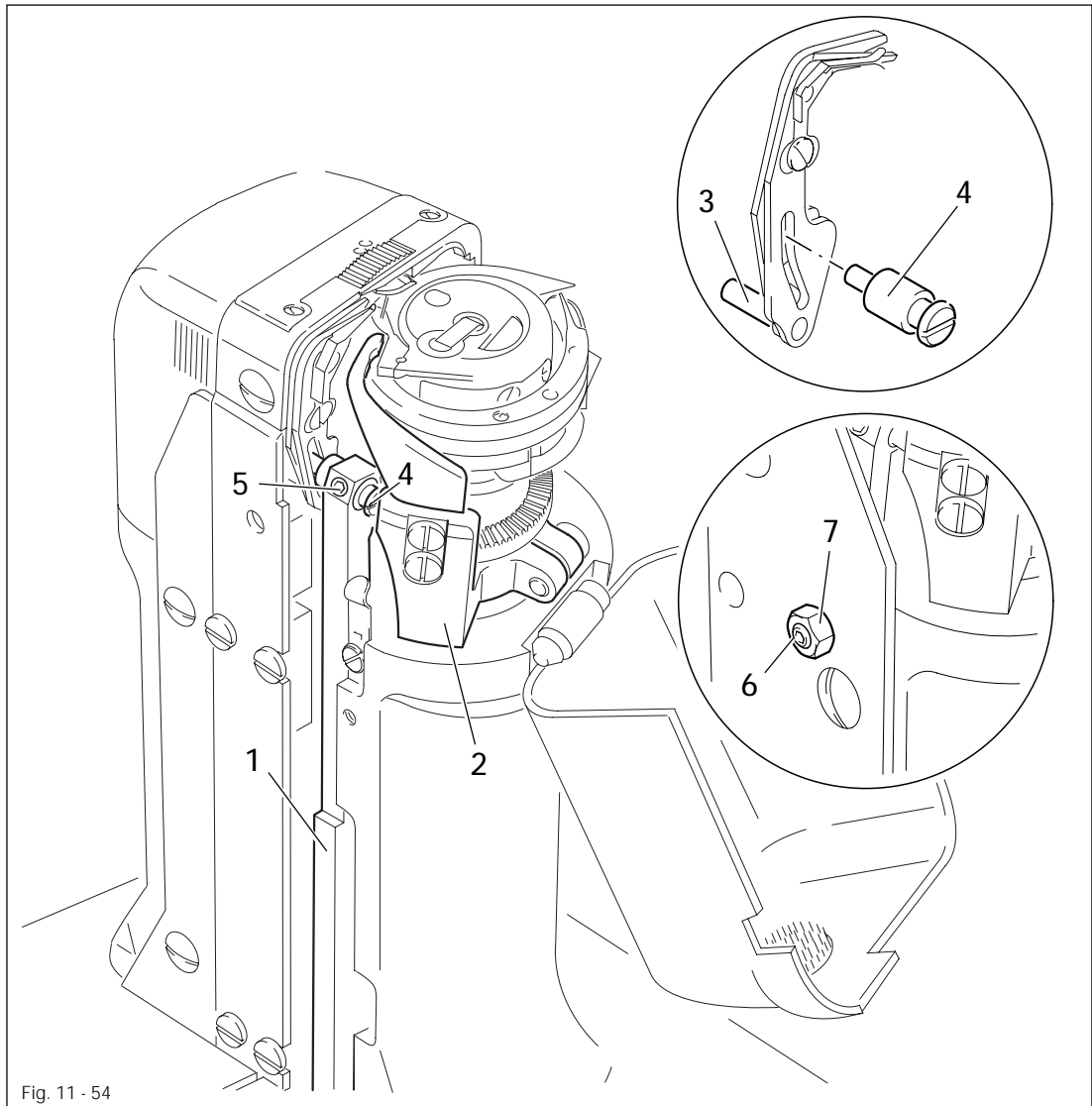

- Swing out driving rod 1.
- Swing out bobbin opener 2 by hand and hold it.
- Insert the cutter with its bearing pin 3 into the bearing bushing of the feed wheel post.
- Swing in driving rod 1 and insert pin 4 in accordance with requirement 1.
- Position the eccentricity of pin 4 so that it faces upwards.
- Tighten screw 5 and screw on the post cover plate.
- Check driving rod 1 for play and friction-free running. If necessary, adjust with screw 6 (nut 7).



For model 474 repeat adjustment on the right post.



## 11.07.13 Eccentric sleeve

### Requirement

1. In its starting position the cutter must be flush with the contour of the needle plate.
2. The cutter must lightly touch the needle plate and the eccentric sleeve 2.

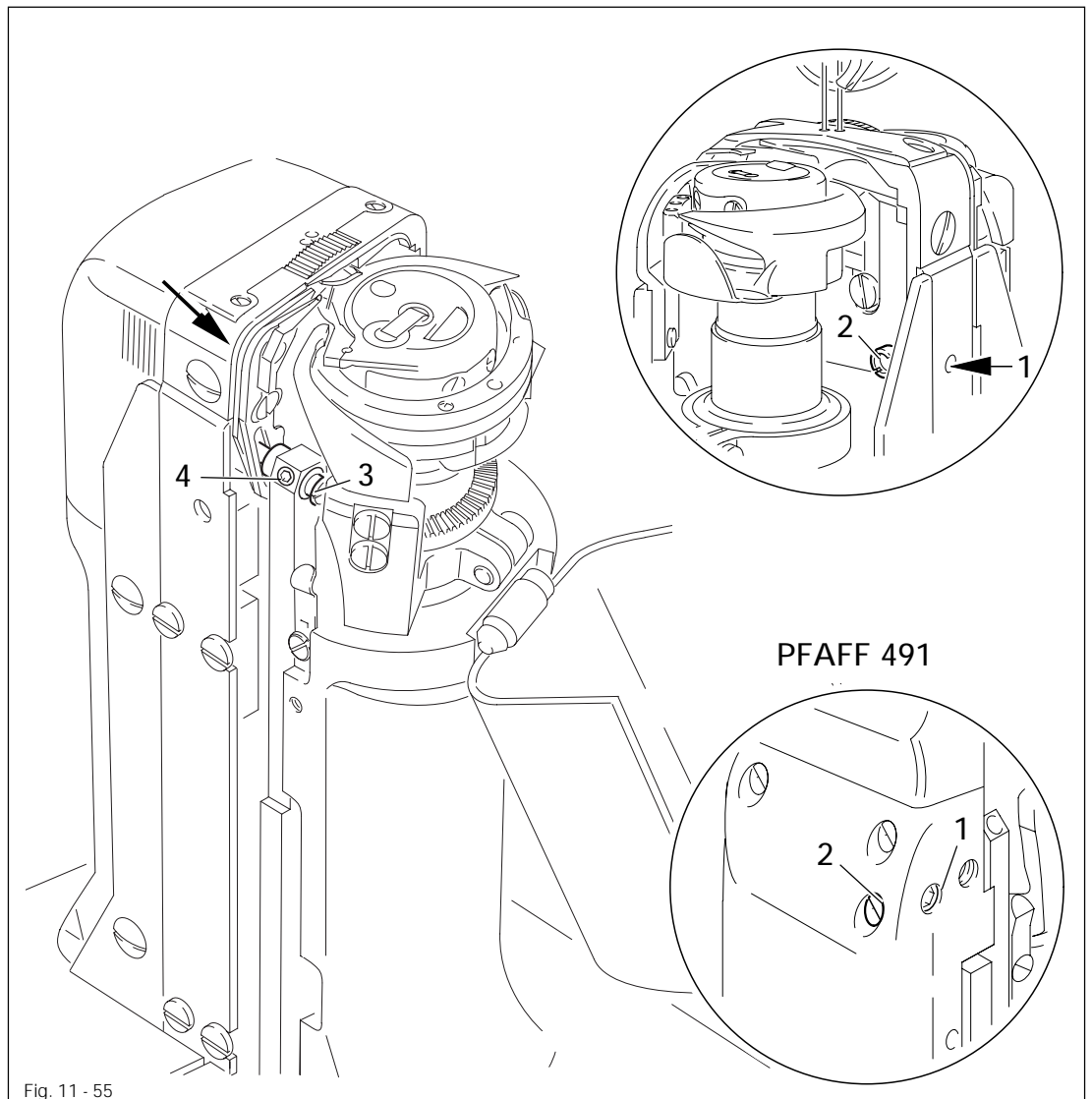
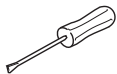

Fig. 11 - 55



- Loosen screw 1 enough so that eccentric sleeve 2 can still be turned.
- Turn eccentric sleeve 2 until the cutter is flush with the needle plate.
- Maintaining this position, move eccentric sleeve 2 laterally in accordance with the requirement.
- Tighten screw 1.
- Press pin 3 (screw 4) lightly against the scissor.



For model 474 repeat adjustment on the right post.

## 11.07.14 Cutter driving rod

### Requirement

1. In its starting position the cutter must be flush with the needle plate contour.
2. At the TDC of the driving rod 2 there must be a safety clearance of at least 0.3 mm between pin 5 and the top end of the cam guide.

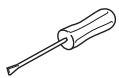
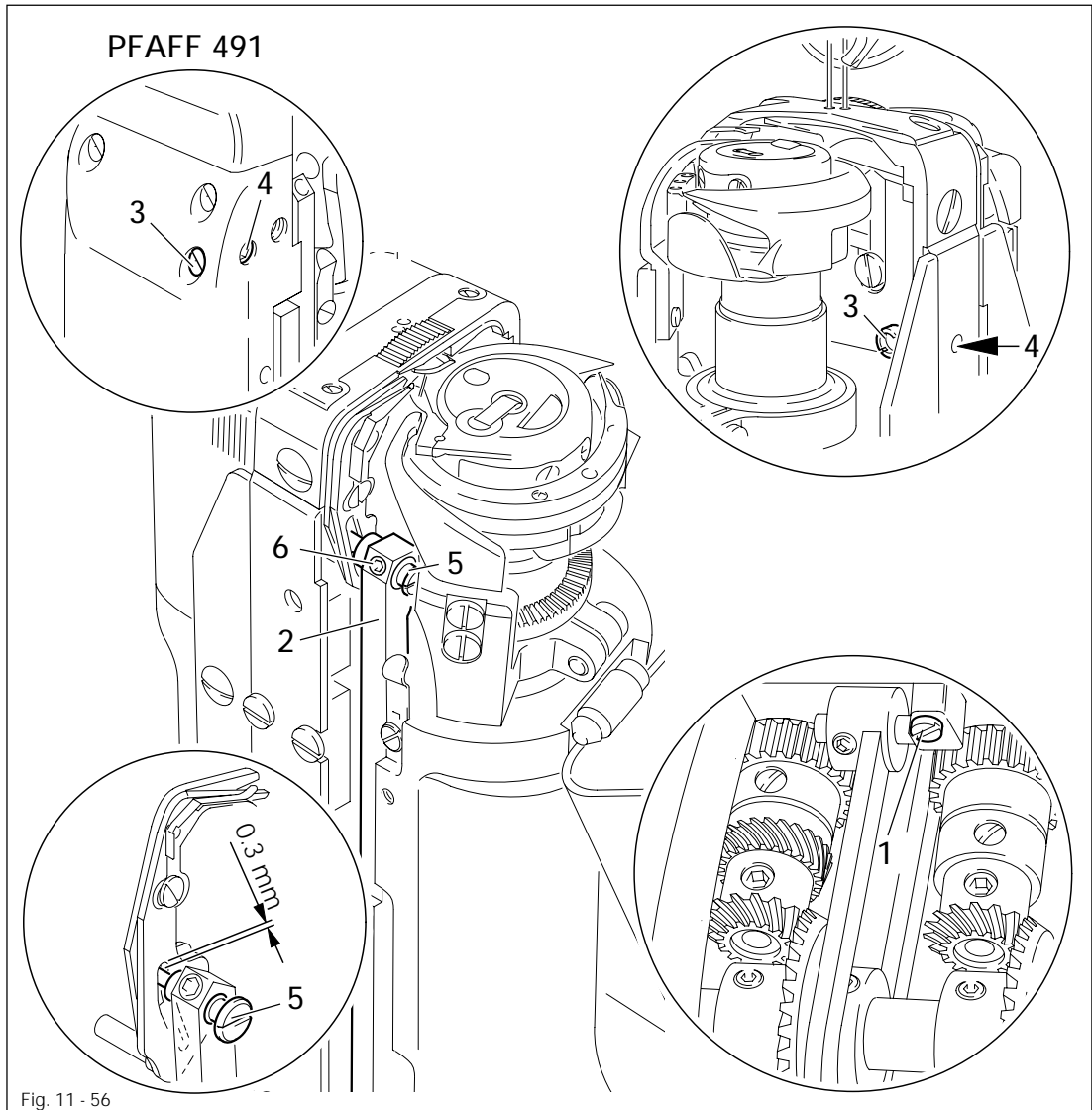

- Bring the needle bar to BDC and activate the engaging lever by hand.
- Bring driving rod 2 to its top point of reversal by turning the handwheel.
- Carry out the alteration on the driving rod 2 (screw 1), the eccentric sleeve 3 (screw 4) and/or the eccentric pin 5 (screw 6) in accordance with the **requirement**.
- Check the **requirement** from chapter 11.07.13 Eccentric sleeve.
- Bring the thread trimmer to its starting position using the handwheel.



If using the 474 model, carry out the same adjustment on the second post.

## 11.07.15 Cutter function test

**Requirement**

1. The threads must be cut neatly.
2. After being trimmed, the bobbin thread must be held securely by the thread trapper.

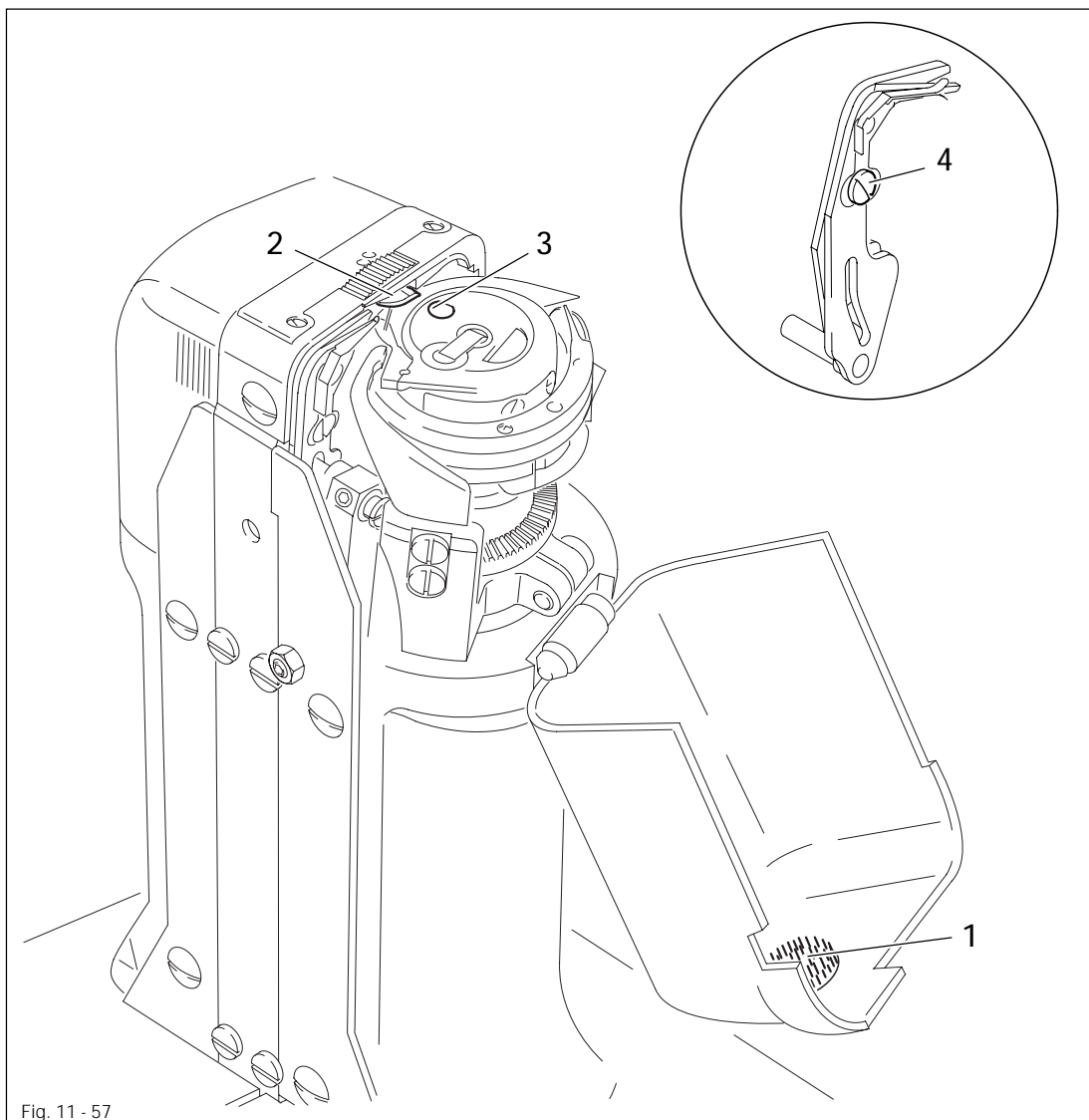
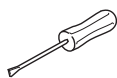

Fig. 11 - 57



- Turn the machine on.
- Sew a few stitches and turn the on/off switch off.
- Activate the engaging lever by hand and close the post cover while ensuring that pressure disk 1 is inserted into the post cap.
- Bring the needle bar to TDC by turning the handwheel and open the post cover.
- In this position the needle and bobbin threads must be held by the catching lug 2 of bobbin case and the needle thread must be held by the catching lug 3 of bobbin.
- If the needle thread is not held, insert a new pressure disk 1 (part no. 91-119 492-91).
- Turn the handwheel and observe the cutting process.

---

## *Adjustment*

---

- When the cutter is moving forward, the thread trapper must first trap and hold the threads reliably on the cutter (if necessary adjust the thread trapper as required after loosening retaining screw 4).
- As the process continues, both the bobbin thread and the part of the thread loop closest to the cutter, which is held by the catching lug must be cut perfectly.
- If the threads are not cut at all or not cut fully, check the **chapter 11.07.14 Cutter driving rod** again.
- Carry out a check according to the **requirement**.

## 11.08 Tension release (only on machines with thread tension control -906/10)

### Requirement

When the magnets 1 are activated, the tension discs 3 must be at least 0.5 mm apart.

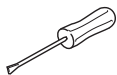
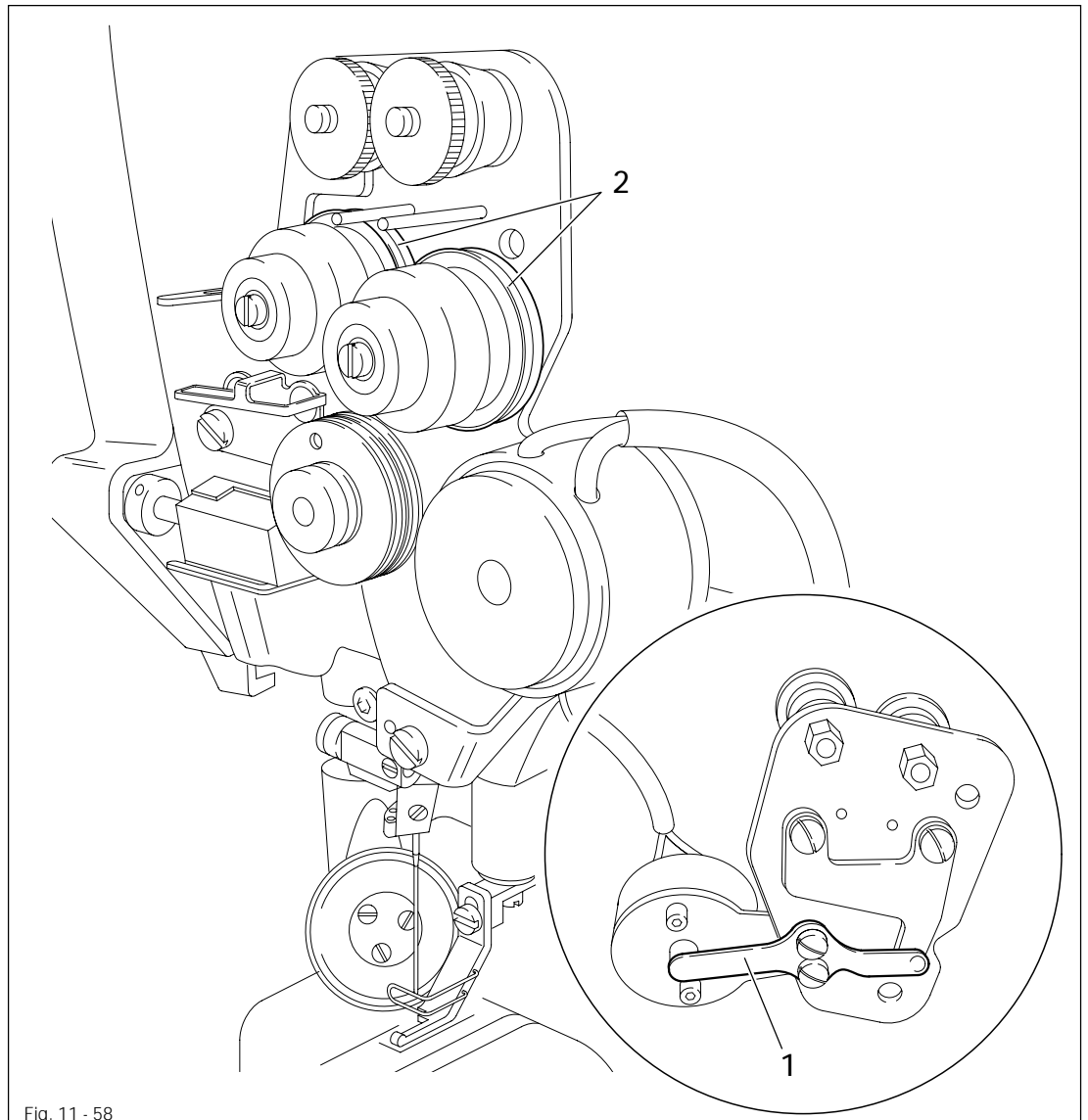

- Adjust lever 1 according to the requirement.



Using parameter it is possible to set the moment when the tension is released (see Chapter 11.10 Parameter settings).

## Adjustment

### 11.09 Adjustment of backtacking mechanism -911/..

#### 11.09.01 Needle in needle hole (only for PFAFF 471 and 491)

##### Requirement

When the maximum stitch length is set, the needle must be the same distance from the inside edge of the needle hole, both for forward and reverse stitch.

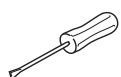
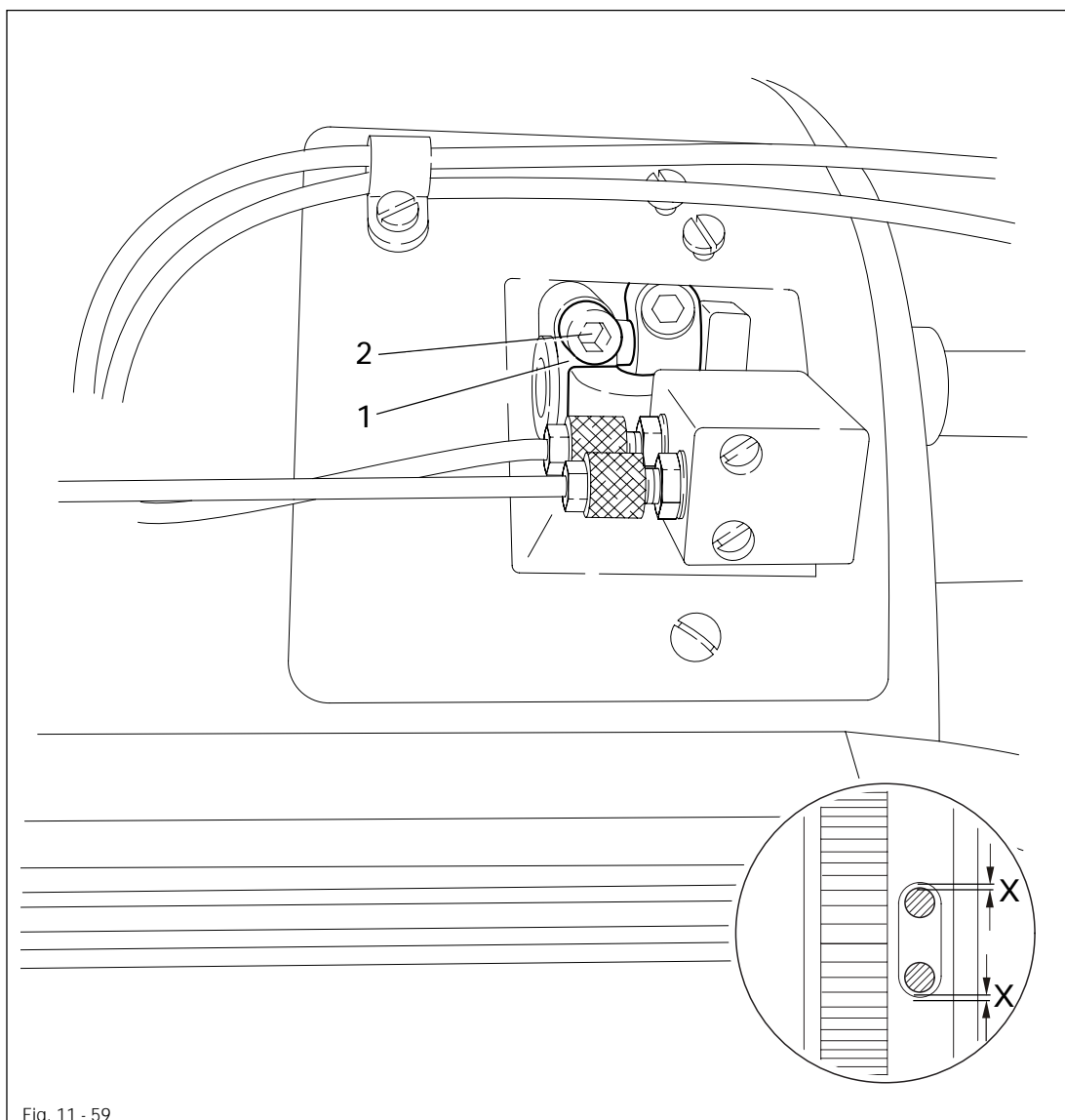

- Turn crank 1 (screws 2) according to the requirement.

## 11.09.02 Coupling for roller presser drive

### Requirement

There must be a distance of 3 mm between coupling half 1 and locking disc 3 of the drive mechanism.

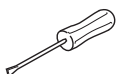
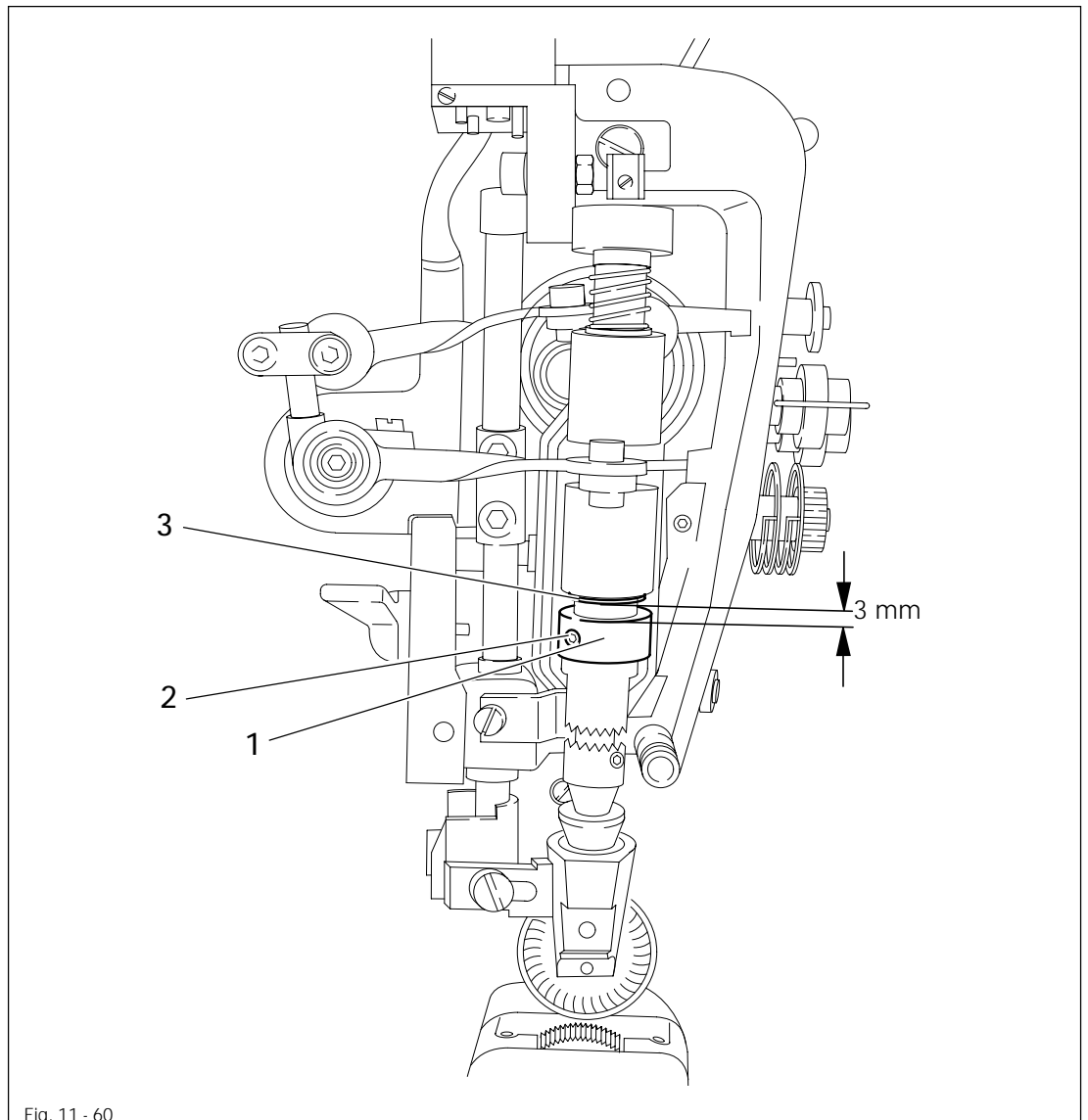

- Adjust coupling half 1 (screw 2) according to the requirement.

## 11.09.03 Bevel gears for feed wheel drive (on the PFAFF 471 and 474)

### Requirements

1. Bevel gear 3 must fit well on the left side.
2. There must be a distance of 14 mm between bevel gear 3 and bevel gear 5.

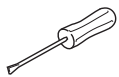
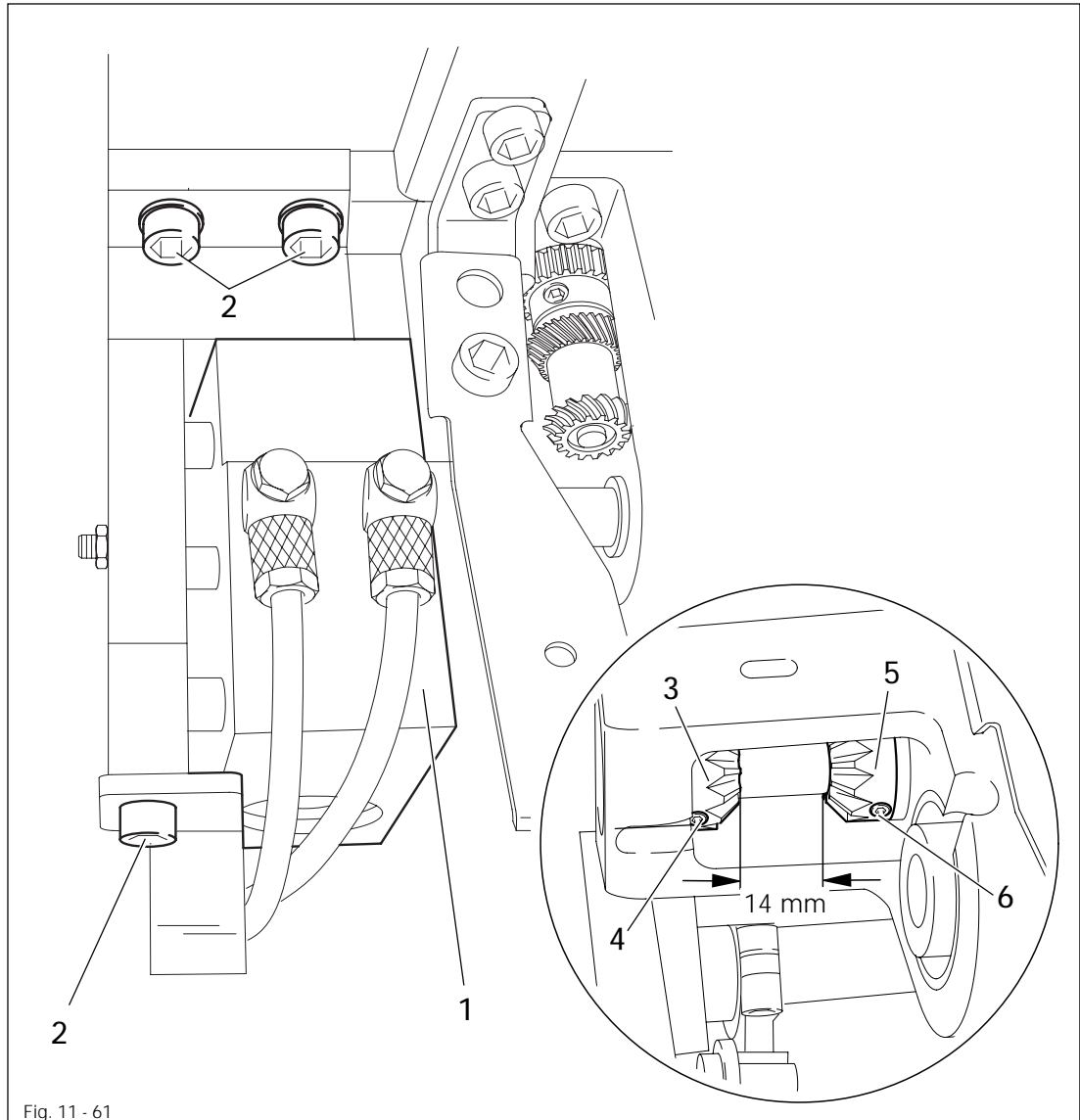

- Remove control unit 1 (screws 2).
- Adjust bevel gear 3 (screws 4) according to requirement 1.
- Adjust bevel gear 5 (screws 6) according to requirement 2.



## 11.09.04 Bevel gear play (on the PFAFF 471 and 474)

### Requirements

1. When sewing forwards, there must be a slight play between bevel gears 6 and 7.
2. When sewing backwards, there must be a slight play between bevel gears 6 and 8.

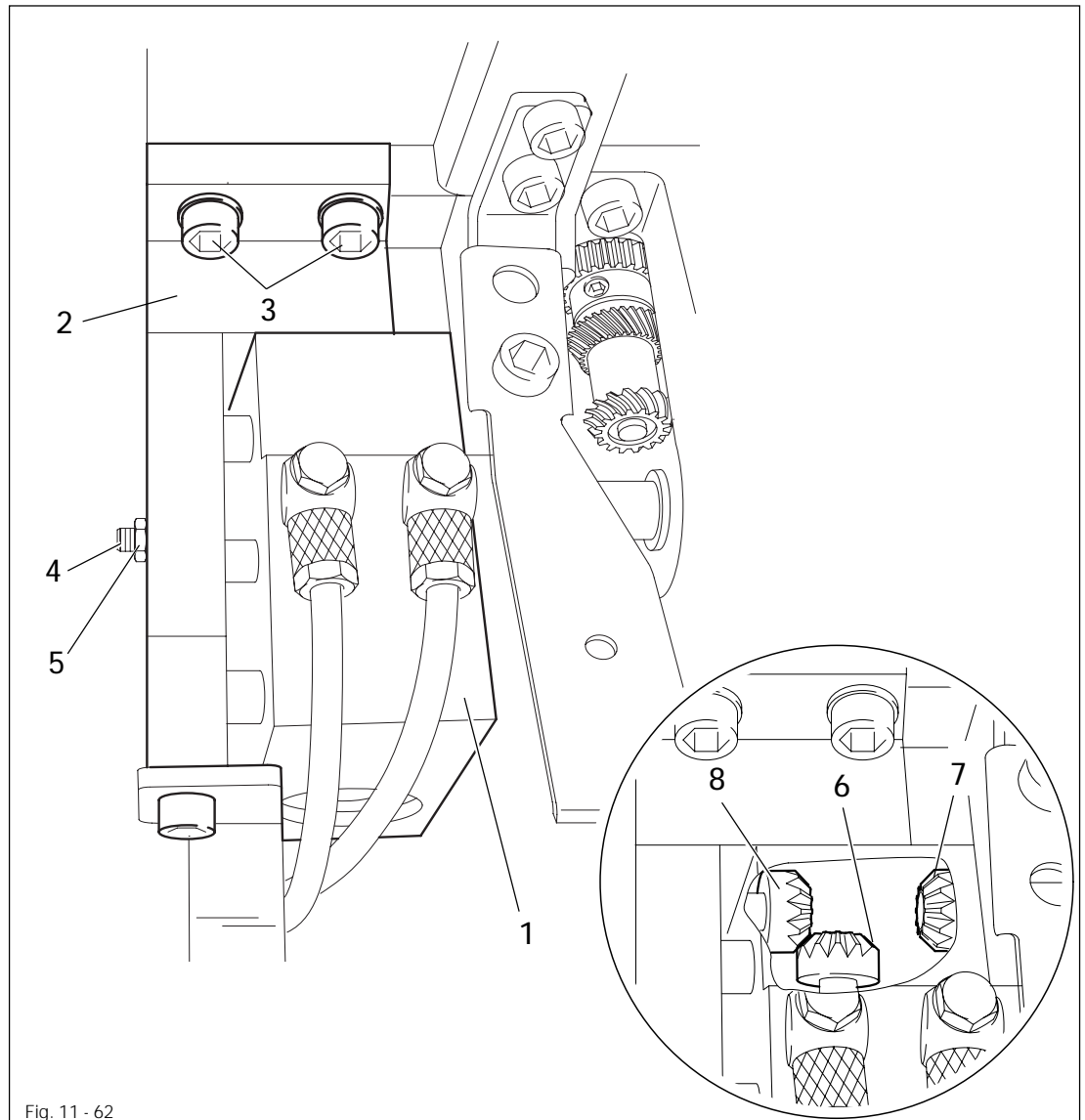
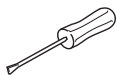

Fig. 11 - 62



- Disconnect air supply of the air filter/lubricator.
- Move unit 1 by hand as far as possible to the right.
- Adjust bracket 2 (screws 3) according to **requirement 1**.
- Move unit 1 by hand as far as possible to the left.
- Adjust screw 4 (nut 5) according to **requirement 2**.

## 11.09.05 Bevel gears for feed wheel drive (on the PFAFF 491)

### Requirements

1. The right side of bevel gear 1 must be flush with its drive shaft (see arrow).
2. There must be a distance of 13 mm between bevel gear 3 and bevel gear 1.

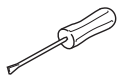
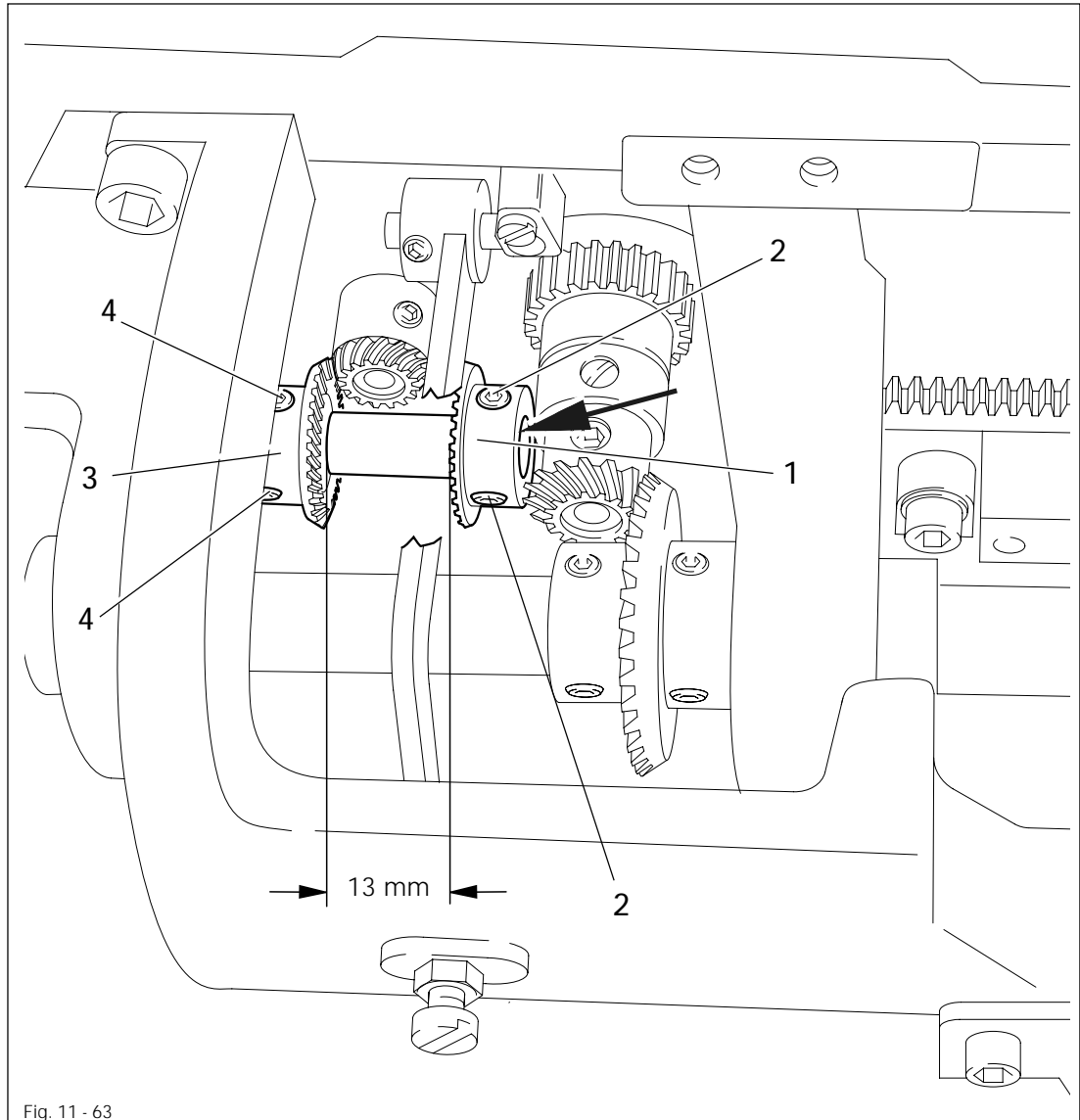

- Adjust bevel gear 1 (screws 2) according to requirement 1.
- Adjust bevel gear 3 (screws 4) according to requirement 2.

## 11.09.06 Bevel gear play (on the PFAFF 491)

**Requirements**

1. When sewing forwards, there must be a slight play between bevel gears 6 and 7.
2. When sewing backwards, there must be a slight play between bevel gears 6 and 8.

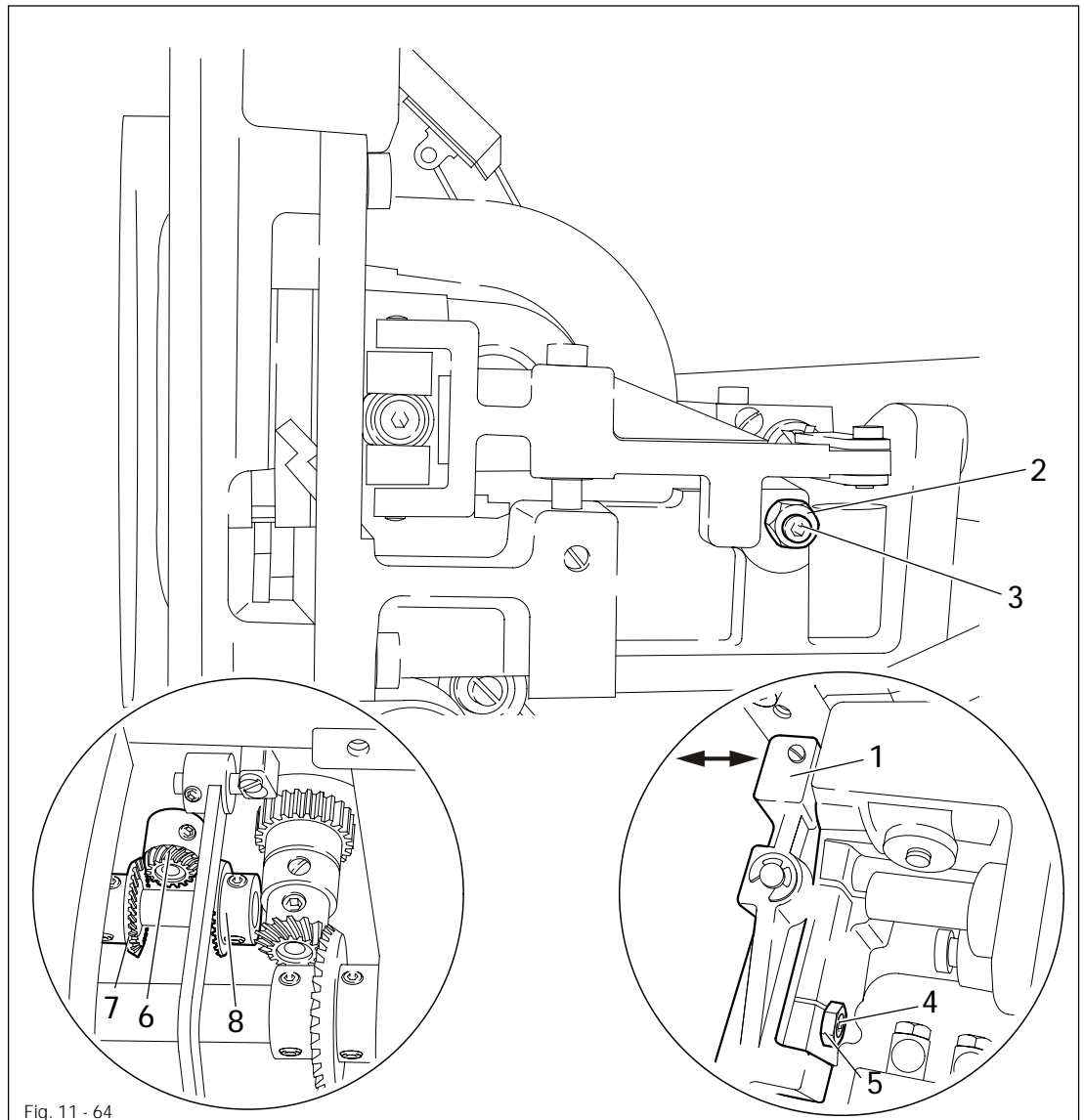
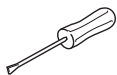

Fig. 11 - 64



- Disconnect air supply of the air filter/lubricator.
- Move unit 1 by hand as far as possible to the right (see arrow).
- Adjust screw 2 (nut 3) according to **requirement 1**.
- Move unit 1 by hand as far as possible to the left (see arrow).
- Adjust screw 4 (nut 5) according to **requirement 2**.

## 11.10 Parameter settings for the Quick-Ministop Motor

Parameters can be set on the operating panel via display.

Group	Parameter	Significance	Setting	Standard value
6	601	Cut I = yes II = no		I
	607	Max. speed	100 - 2800	2800
	609	Cutting speed 1	30 - 300	180
7	700	Needle position Needle reference position	0 - 191	
	701	Angle setting I = Set synchronizer with balance wheel II = Set synchronizer with buttons " + " and " - "		I
	702	Needle position 1 (needle lowered)	0 - 191	20
	703	Needle position 2 (take-up lever raised)	0 - 191	175
	707	Needle position 9 (Start tension release signal 2)	0 - 191	140



Further displays and information are available in the Motor Service Manual.



# PFAFF

**G.M. PFAFF KAISERSLAUTERN  
INDUSTRIEMASCHINEN AG**

Postfach 3020  
D-67653 Kaiserslautern

Königstr. 154  
D-67655 Kaiserslautern

Telefon: (0631) 200-0  
Telefax: (0631) 17202  
E-Mail: [info@pfaff-industrial.com](mailto:info@pfaff-industrial.com)

Gedruckt in der BRD  
Printed in Germany  
Imprimé en R.F.A.  
Impreso en la R.F.A.