

PFAFF

571

574

Instruction Manual

591

This instruction manual applies to machines from the following serial numbers onwards:

2619305 →



This instruction manual applies to all versions and subclasses listed under "Specifications".

Reprinting, copying or translation of PFAFF instruction manuals, whether in whole or in part, is not permitted without our prior permission and not without written indication of the source.

PFAFF Industrie Maschinen AG

Postfach 3020

D-67653 Kaiserslautern

Königstr. 154

D-67655 Kaiserslautern

Editing/illustrations

Verlag TD

D-77901 Lahr

		Chapter - Page
	Contents	Chapter - Page
1	Safety	1 - 1
1.01	Directives	1 - 1
1.02	General notes on safety	1 - 1
1.03	Safety symbols	1 - 2
1.04	Important points for the user	1 - 2
1.05	Operating and specialist personnel	1 - 3
1.05.01	Operating personnel	1 - 3
1.05.02	Specialist personnel	1 - 3
1.06	Danger	1 - 4
2	Proper use	2 - 1
3	Specifications	3 - 1
3.01	PFAFF 571, 574, 591	3 - 1
3.02	Needles and threads	3 - 2
3.03	Possible models and subclasses	3 - 2
4	Disposal of Machine	4 - 1
5	Transportation, packing and storage	5 - 1
5.01	Transportation to customer's premises	5 - 1
5.02	Transportation inside the customer's premises	5 - 1
5.03	Disposal of packing materials	5 - 1
5.04	Storage	5 - 1
6	Explanation of symbols	6 - 1
7	Controls	7 - 1
7.01	On/off switch	7 - 1
7.02	Keys on the machine head (only for machines with -911/..)	7 - 1
7.03	Bobbin thread monitoring with stitch counting	7 - 2
7.04	Pedal	7 - 2
7.05	Lever for lifting roller presser	7 - 3
7.06	Knee lever	7 - 3
7.07	Key for setting stitch length	7 - 4
7.08	Swing out roller presser	7 - 4
7.09	Edge trimmer -725/04 for 571	7 - 5
7.10	Edge trimmer -725/04 for 574 and 591	7 - 6
7.11	Edge trimmer -726/05 for 591	7 - 7
7.12	Control panel	7 - 8
7.12.01	Screen displays	7 - 8
7.12.02	Function keys	7 - 8
8	Installation and commissioning	8 - 1
8.01	Installation	8 - 1
8.01.01	Adjusting the table height	8 - 1
8.01.02	Fitting the tilt lock	8 - 2

Contents	Chapter - Page
8.01.03 Fitting the machine cover	8 - 2
8.02 Mounting the flange motor	8 - 3
8.02.01 Mounting the flange motor to the bearing plate	8 - 3
8.02.02 Mounting the flange motor to the machine	8 - 3
8.02.03 Connecting the plug-in connections and earth cables	8 - 4
8.02.04 Mounting the toothed belt and adjusting the tension	8 - 5
8.02.05 Mounting the belt guard of the flange motor	8 - 5
8.02.06 Connecting the safety switch	8 - 6
8.02.07 Checking the start inhibitor function	8 - 6
8.02.08 Basic setting of the machine drive unit	8 - 7
8.03 Fitting the reel stand	8 - 8
8.04 Commissioning	8 - 8
8.05 Switching the machine on/off	8 - 8
8.06 Tilted work base	8 - 9
8.07 Table top cutout	8 - 10
9 Setting up	9 - 1
9.01 Inserting the needle on model 571 and 591	9 - 1
9.02 Inserting the needle on model 574	9 - 2
9.03 Winding the bobbin thread; adjusting the primary thread tension	9 - 3
9.04 Removing/Inserting the bobbin case	9 - 4
9.05 Threading the bobbin case/Adjusting the bobbin thread tension	9 - 4
9.06 Threading the needle thread and regulating its tension on model 571 and 591	9 - 5
9.07 Threading the needle thread and regulating its tension on model 574	9 - 6
9.08 Setting the stitch length	9 - 7
9.09 Entering the start and end backtacks	9 - 8
9.10 Setting the stitch count function for the bobbin thread control	9 - 9
10 Sewing	10 - 1
10.01 Darning program (this function is used mainly in the textile industry)	10 - 2
10.02 Counted seam	10 - 2
11 Care and maintenance	11 - 1
11.01 Cleaning	11 - 1
11.02 Oiling the hook	11 - 2
11.03 Oil bowl for hook lubrication	11 - 2
11.04 Filling the oil reservoir of the thread lubrication unit	11 - 3
11.05 Oiling the edge trimmer -726/05	11 - 3
11.06 Lubricating the bevel gears	11 - 4
11.07 Checking/adjusting the air pressure	11 - 5
11.08 Cleaning the air filter of the air-filter/lubricator	11 - 5
12 Adjustment	12 - 1
12.01 Notes on adjustment	12 - 1
12.02 Tools, gauges and other accessories	12 - 1
12.03 Abbreviations	12 - 1

Contents		Chapter - Page
12.04	Adjusting the basic machine	12 - 2
12.04.01	Needle position in sewing direction on the PFAFF 571 and 591	12 - 2
12.04.02	Needle position in sewing direction on the PFAFF 574	12 - 3
12.04.03	Preliminary adjustment of the needle height	12 - 4
12.04.04	Needle rise, hook clearance, needle height and needle guard on the PFAFF 571	12 - 5
12.04.05	Needle rise, hook clearance, needle height and needle guard on the PFAFF 574	12 - 7
12.04.06	Needle rise, hook clearance, needle height and needle guard on the PFAFF 591	12 - 9
12.04.07	Needle position crosswise to sewing direction on the PFAFF 571	12 - 11
12.04.08	Needle position crosswise to sewing direction on the PFAFF 574	12 - 12
12.04.09	Needle position crosswise to sewing direction on the PFAFF 591	12 - 13
12.04.10	Height and stroke of the bobbin case opener	12 - 14
12.04.11	Height of the feed wheel on the PFAFF 571	12 - 15
12.04.12	Height of the feed wheel on the PFAFF 574	12 - 16
12.04.13	Height of the feed wheel on the PFAFF 591	12 - 17
12.04.14	Stitch length control eccentric	12 - 18
12.04.15	Stitch length scale disk	12 - 19
12.04.16	Shaft crank to feed wheel drive	12 - 20
12.04.17	Shaft crank to roller presser drive	12 - 21
12.04.18	Clearance between roller presser and feed wheel	12 - 22
12.04.19	Roller presser	12 - 23
12.04.20	Stitch length on stitch length scale	12 - 24
12.04.21	Synchronization of roller presser and feed wheel	12 - 25
12.04.22	Retainer (only on model 574)	12 - 26
12.04.23	Knee lever	12 - 27
12.04.24	Needle thread tension release	12 - 28
12.04.25	Thread check spring (PFAFF 571 and 591)	12 - 29
12.04.26	Thread check springs (PFAFF 574)	12 - 30
12.04.27	Bobbin winder	12 - 31
12.04.28	Pressure of roller presser	12 - 32
12.04.29	Lubrication	12 - 33
12.04.30	Re-engage safety coupling	12 - 34
12.05	Adjusting the edge trimmer -725/04	12 - 35
12.05.01	Position of the knife holder on model 571	12 - 35
12.05.02	Position of the knife holder on models 574 and 591	12 - 36
12.05.03	Knife stroke on model 571	12 - 37
12.05.04	Knife stroke on models 574 and 591	12 - 38
12.05.05	Cutting stroke on model 571	12 - 39
12.05.06	Cutting stroke on models 574 and 591	12 - 40
12.05.07	Knife position	12 - 41
12.06	Adjusting the thread trimmer -726/05 on model 591	12 - 42
12.06.01	Position of the knife to the needle plate	12 - 42
12.06.02	Knife position crosswise to sewing direction	12 - 43
12.06.03	Knife height	12 - 44
12.06.04	Cutting stroke	12 - 45
12.06.05	Knife stroke	12 - 46

	Contents	Chapter - Page
12.07	Adjusting the thread trimmer -900/81	12 - 47
12.07.01	Resting position of the roller lever / radial position of the control cam	12 - 47
12.07.02	Position of the thread catcher holder	12 - 48
12.07.03	Distance between thread catcher and needle plate	12 - 49
12.07.04	Position of the thread catcher	12 - 50
12.07.05	Knife position and knife pressure	12 - 51
12.07.06	Bobbin thread retaining spring	12 - 52
12.07.07	Manual cutting test	12 - 53
12.07.08	Releasing the tension	12 - 54
12.07.09	Linkage rod (only for the PFAFF 574)	12 - 55
12.08	Adjustment of backtacking mechanism -911/..	12 - 56
12.08.01	Needle in needle hole (only for PFAFF 571 and 591)	12 - 56
12.08.02	Coupling for roller presser drive	12 - 57
12.08.03	Bevel gears for feed wheel drive (on the PFAFF 571 and 574)	12 - 58
12.08.04	Bevel gear play (on the PFAFF 571 and 574)	12 - 59
12.08.05	KBevel gears for feed wheel drive (on the PFAFF 591)	12 - 60
12.08.06	Bevel gear play (on the PFAFF 591	12 - 61
12.09	Parameter settings	12 - 62
12.09.01	Selecting the user level	12 - 62
12.09.02	Example of a parameter input	12 - 63
12.09.03	List of parameters	12 - 64
12.09.04	Reset / Cold start	12 - 65
12.10	Internet update of the machine software	12 - 66
12.11	Explanation of the error signals	12 - 67
13	Wearing parts	13 - 1
14	Circuit diagrams	14 - 1

1 Safety

1.01 Directives

This machine is constructed in accordance with the European regulations contained in the conformity and manufacturer's declarations.

In addition to this Instruction Manual, observe also all generally accepted, statutory and other regulations and legal requirements and all valid environmental protection regulations! The regionally valid regulations of the social insurance society for occupational accidents or other supervisory organisations are to be strictly adhered to!

1.02 General notes on safety

- This machine may only be operated by adequately trained operators and only after the Instruction Manual has been completely read and understood!
- All Notes on Safety and Instruction Manuals of the motor manufacturer are to be read before operating the machine!
- The danger and safety instructions on the machine itself are to be followed!
- This machine may only be used for the purpose for which it is intended and may not be operated without its safety devices. All safety regulations relevant to its operation are to be adhered to.
- When exchanging sewing tools (e.g. needle, roller presser, needle plate or bobbin), when threading the machine, when leaving the machine unattended and during maintenance work, the machine is to be separated from the power supply by switching off the On/Off switch or by removing the plug from the mains!
- Everyday maintenance work is only to be carried out by appropriately trained personnel!
- Repairs and special maintenance work may only be carried out by qualified service staff or appropriately trained personnel!
- Work on electrical equipment may only be carried out by appropriately trained personnel!
- Work is not permitted on parts and equipment which are connected to the power supply! Exceptions to this are only to be found in the regulations EN 50110.
- Modifications and alterations to the machine may only be carried out under observance of all the relevant safety regulations!
- Only spare parts which have been approved by us are to be used for repairs! We expressly point out that any replacement parts or accessories, which are not supplied by us, have not been tested and approved by us. The installation and/or use of any such products can lead to negative changes in the structural characteristics of the machine. We shall not be liable for any damage which may be caused by non-original parts.

1.03

Safety symbols



Danger!
Points to be observed.



Danger of injury for operating and specialist personnel!



Caution

Do not operate without finger guard and safety devices.
Before threading, changing bobbin and needle, cleaning
etc. switch off main switch.

1.04

Important points for the user

- This Instruction Manual is a component part of the machine and must be available to the operating personnel at all times.
- The Instruction Manual must be read before operating the machine for the first time.
- The operating and specialist personnel is to be instructed as to the safety equipment of the machine and regarding safe work methods.
- It is the duty of the user to only operate the machine in perfect running order.
- It is the obligation of the user to ensure that none of the safety mechanisms are removed or deactivated.
- It is the obligation of the user to ensure that only authorized persons operate and work on the machine.

Further information can be obtained from your PFAFF agent.

1.05 Operating and specialist personnel

1.05.01 Operating personnel

Operating personnel are persons responsible for the equipping, operating and cleaning of the machine as well as taking care of faults arising in the sewing area.

The operating personnel is obliged to observe the following points and must:

- always observe the Notes on Safety in the Instruction Manual!
- never use any working methods which could limit the level of safety in using the machine!
- not wear loose-fitting clothing or jewellery such as chains or rings!
- also ensure that only authorized persons have access to the potentially dangerous area around the machine!
- always immediately report to the person responsible any changes in the machine which may limit its safety!

1.05.02 Specialist personnel

Specialist personnel are persons with a specialist education in the fields of electrics, electronics and mechanics. They are responsible for the lubrication, maintenance, repair and adjustment of the machine.

The specialist personnel is obliged to observe the following points and must:

- always observe the Notes on Safety in the Instruction Manual!
- switch off the On/Off switch before carrying out adjustments or repairs and ensure that it cannot be switched on again unintentionally!
- never work on parts which are still connected to the power supply! Exceptions are contained only in the regulations EN 50110.
- replace the protective coverings and close the electrical control box after all repairs or maintenance work!

1.06

Danger



A working area of 1 meter is to be kept free both in front of and behind the machine while it is in operation so that it is always easily accessible.



Never reach into the sewing area while sewing! Danger of injury by the needle!



Never leave objects on the table while adjusting the machine settings!
Objects can become trapped or be slung away! Danger of injury!



Do not operate the machine without support 1! Danger due to top-heavy sewing head!
Machine can tip over backwards when tilted!

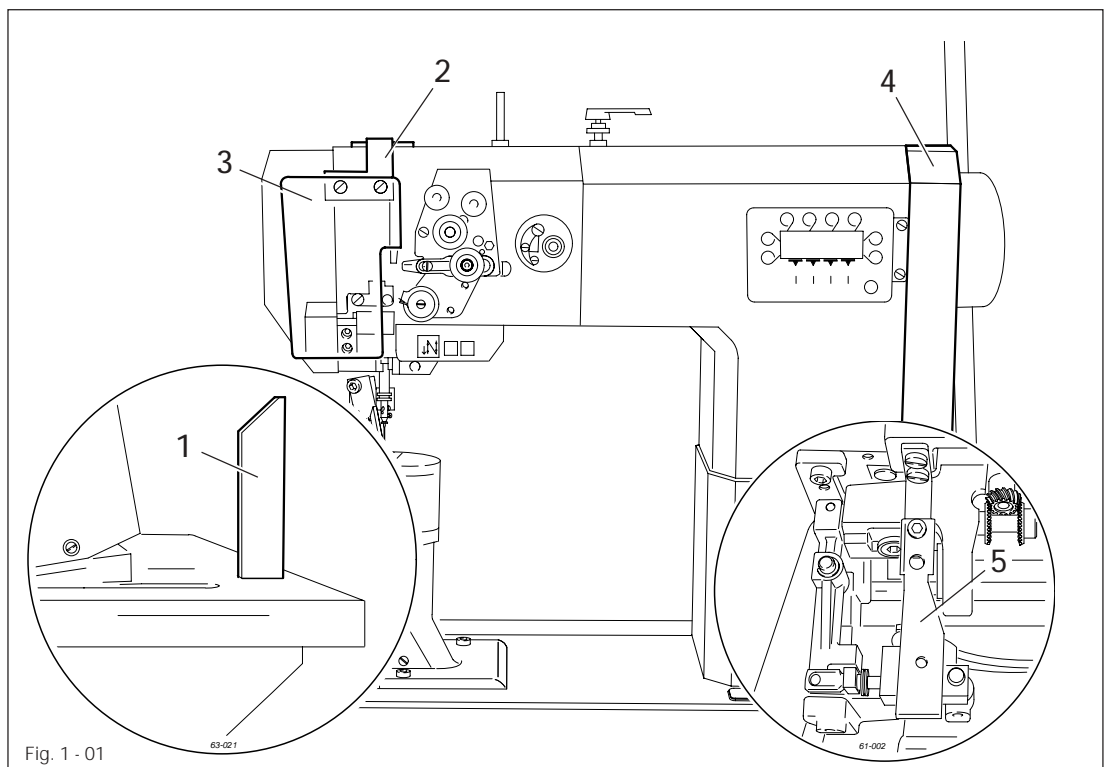

Fig. 1 - 01



Switch the machine off before tilting it backwards!
Danger of injury if the machine is started accidentally!



Do not operate the machine without its take-up-lever guard 2!
Danger of injury due to the motion of the take-up lever!



On machines with thread lubricator, only operate the machine with the eye guard 3 lowered! The eye guard 3 protects the eyes from oil particles from the thread lubrication.



Do not operate the machine without belt guard 4!
Danger of injury by rotating drive belt!



Do not operate the machine without tilt lock 5!
Danger of crushing between sewing head and table top!

2

Proper use

The PFAFF 571 is a single needle, high-speed post bed sewing machine (post to the left of the needle) with driven feed wheel and roller presser and synchronized needle.

The PFAFF 574 is a two-needle, high-speed post bed sewing machine with driven feed wheel and roller presser

The PFAFF 591 is a single needle, high-speed post bed sewing machine (post to the right of the needle) with driven feed wheel and roller presser and synchronized needle.

The machines are used for sewing lockstitch seams in the leather and upholstery industries.



Any use of these machines which is not approved by the manufacturer shall be considered as improper use! The manufacturer shall not be liable for any damage arising out of improper use! Proper use shall also be considered to include compliance with the operation, adjustment, service and repair measures specified by the manufacturer!

3 Specifications

3.01 PFAFF 571, 574 , 591 ▲

Stitch type: 301 (lockstitch)
Clearance under roller presser: 7 mm
Clearance width: 245 mm
Clearance height: 115 mm
Post height: 180 mm

Sewing head dimensions:

Length: approx. 615 mm
Width: approx. 240 mm
Height (above table): approx. 500 mm
Bedplate dimensions: 518 x 177 mm

Max. speed:

PFAFF 571, 574, 591 Model A + B 3000 spm ♦
PFAFF 574, 591 Model C 2000 spm ♦
Cutting depth (for -725/.. and -726/..): 0.8 – 2.5 mm
Cutting speed (for -725/.. and -726/..): 2800 cuts/min.

Connection data:

Operating voltage: 230 V ± 10%, 50/60 Hz
Max. power consumption: 1.2 kVA
Fuse protection: 1 x 16 A, inert

Noise data:

Emission sound level at the workplace at appropriate speed

(Noise measurement in accordance with DIN 45 635-48-A-1, ISO 11204, ISO 3744, ISO 4871)

PFAFF 571 and 591, model A + B at a speed of 2400 spm.: $L_{pA} = 79$ dB(A) ■
PFAFF 574, model C at a speed of 1600 spm.: $L_{pA} = 75$ dB(A) ■
PFAFF 591, model C at a speed of 1600 spm.: $L_{pA} = 73$ dB(A) ■

Net weight of sewing head: approx. 61 kg

Gross weight of sewing head: approx. 71 kg

▲ Subject to alteration

♦ Dependent on material, work operation and stitch length

■ $K_{pA} = 2,5$ dB

3.02 Needles and threads

Model	Thread thickness▲ (Nm) max. synthetic	Needle thickness in 1/100 mm	Needle system for PFAFF 571	Needle system for PFAFF 574	Needle system for PFAFF 591
A	60/3	70	134	-	134
B	40/3	100	134	134 - 35	134
C	15/3	130	-	134 - 35	134

▲ or similar strengths of other types of thread

3.03 Possible models and subclasses

PFAFF 571, 591

Model A For sewing lightweight materials

PFAFF 571, 591

Model B For sewing medium-weight materials

PFAFF 574, 591

Model C For sewing medium-heavy materials

Additional equipment:

Subclass -725/04 Edge trimmer

Subclass -726/05 Edge trimmer

Subclass -900/81 Thread trimmer

Subclass -910/15 Automatic presser foot lifter

Subclass -911/35 Bartacker

Subclass -940/02 Needle plate rounded in sewing direction

4 Disposal of Machine

- Proper disposal of the machine is the responsibility of the customer.
- The materials used for the machine are steel, aluminium, brass and various plastic materials.
The electrical equipment comprises plastic materials and copper.
- The machine is to be disposed of according to the locally valid pollution control regulations; if necessary, a specialist is to be commissioned.



Care must be taken that parts soiled with lubricants are disposed of separately according to the locally valid pollution control regulations!

5 Transportation, packing and storage

5.01 Transportation to customer's premises

The machines are delivered completely packed.

5.02 Transportation inside the customer's premises

The manufacturer cannot be made liable for transportation inside the customer's premises nor to other operating locations. It must be ensured that the machines are only transported in an upright position.

5.03 Disposal of packing materials

The packing materials of this machine comprise paper, cardboard and VCE fibre. Proper disposal of the packing material is the responsibility of the customer.

5.04 Storage

If the machine is not in use, it can be stored as it is for a period of up to six months, but it should be protected against dust and moisture.

If the machine is stored for longer periods, the individual parts, especially the surfaces of moving parts, must be protected against corrosion, e.g. by a film of oil.

Explanation of symbols

6 Explanation of symbols

In this instruction manual, work to be carried out or important information is accentuated by symbols. These symbols have the following meanings:



Note, information



Cleaning, care



Lubrication

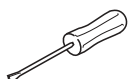

Maintenance, repairs, adjustment, service work
(only to be carried out by technical staff)

7 Controls

7.01 On/off switch

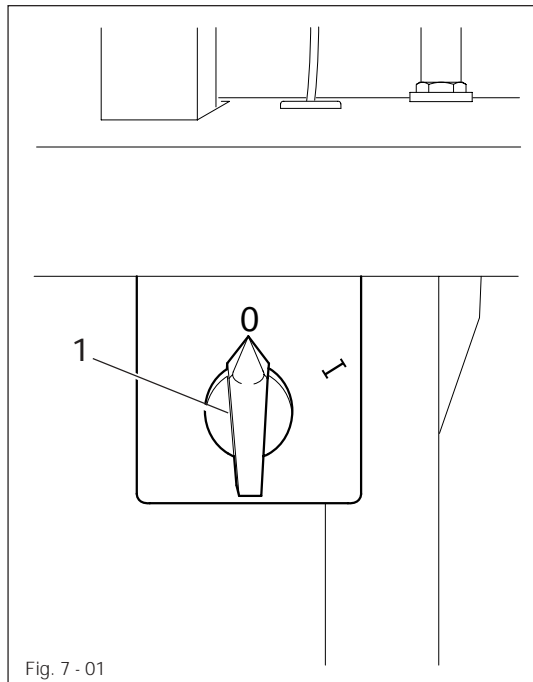

Fig. 7 - 01

- Switch the machine on or off by turning main switch 1.

7.02 Keys on the machine head (only for machines with -911/..)

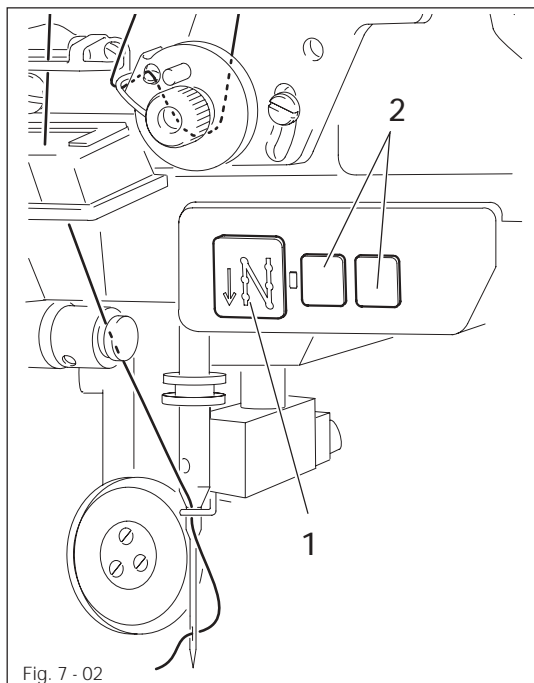

Fig. 7 - 02

- As long as key 1 is pressed during sewing, the machine sews in reverse.
- Keys 2 can be used for parameter settings, see Chapter 12.09 Parameter settings.

7.03

Bobbin thread monitoring with stitch counting

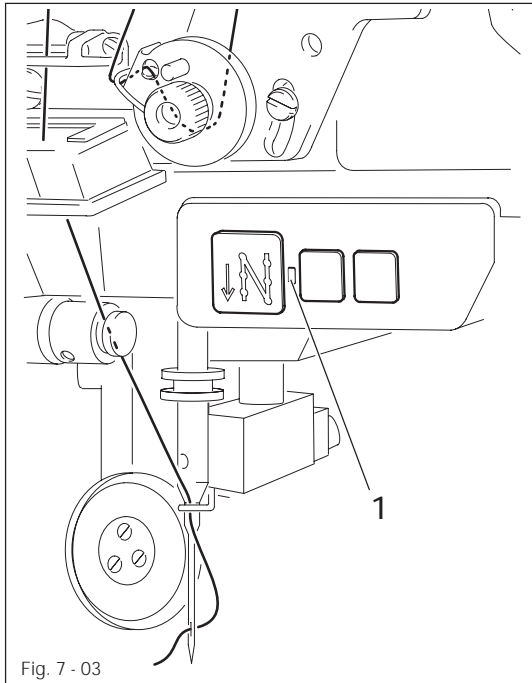

Fig. 7 - 03

Machines without -911/..

- Once the preset number of stitches have been sewn, the machine stops.
- After the thread has been trimmed and the bobbin changed, the stitch counting begins anew.

Machines with 911/..

- About 100 stitches before reaching the preset number of stitches, LED 1 flashes.
- After the thread has been trimmed and the bobbin changed, the stitch counting begins anew.



Presetting the number of stitches, see **Chapter 9.10 Setting the stitch counting function for bobbin thread monitoring.**

7.04

Pedal

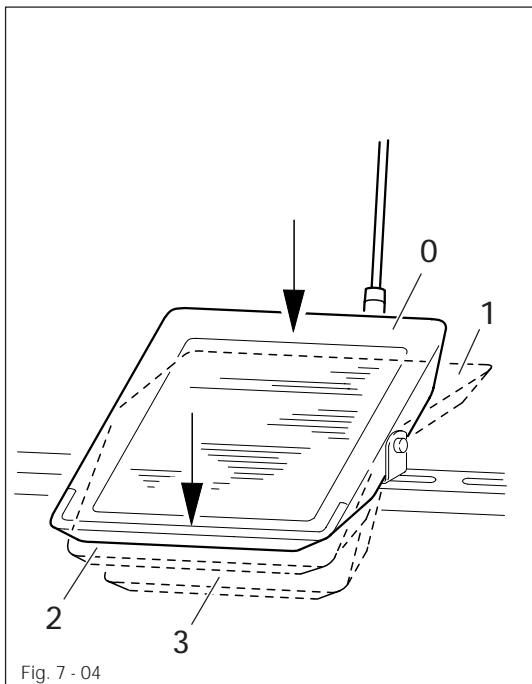
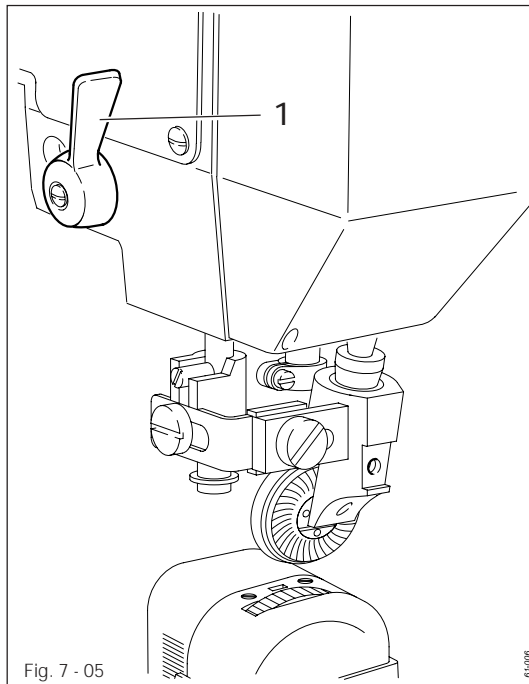

Fig. 7 - 04

- 0 = Neutral position
- 1 = Sewing
- 2 = Raise roller presser (on machines with -910/..)
- 3 = Trim sewing threads (on machines with -900/..)

7.05 Lever for lifting roller presser



- The roller presser can be raised by turning lever 1.

7.06 Knee lever

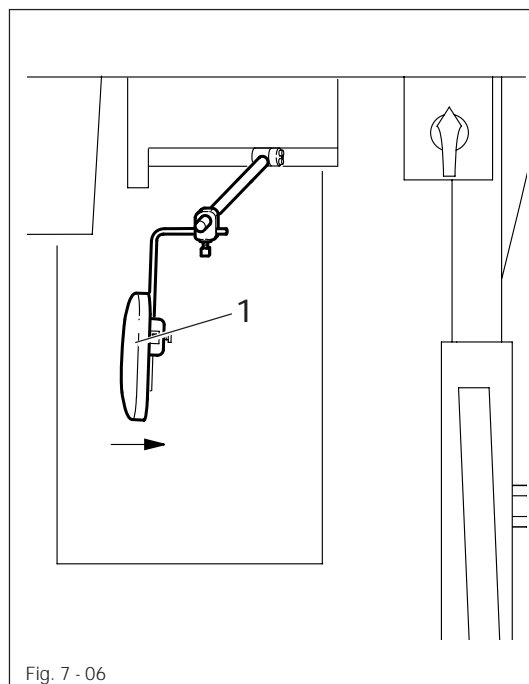

- The roller presser can be raised by pressing the knee lever 1 in the direction of the arrow.

7.07 Key for setting stitch length

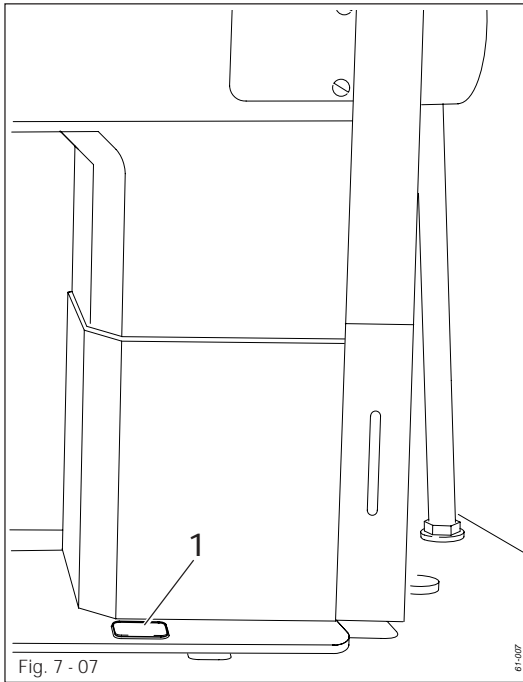

- The stitch length is set by pressing key 1 and turning the balance wheel (see Chapter 9.08 Setting the stitch length).

7.08 Swing out roller presser

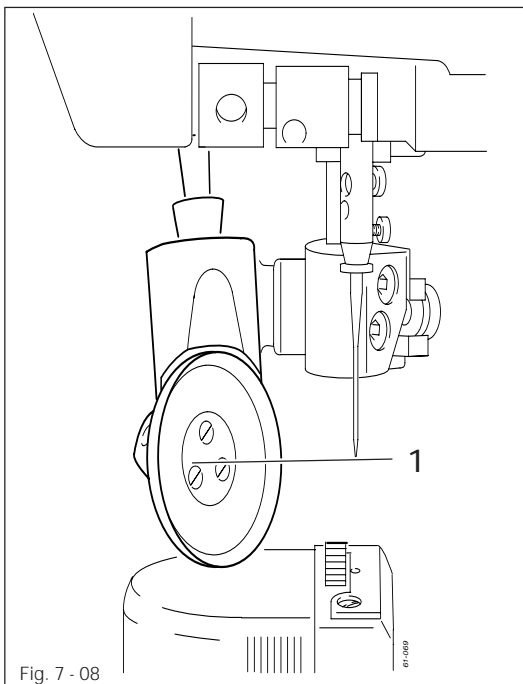

- When the roller presser is raised, it can be swung out by pulling it lightly downwards.

7.09 Edge trimmer -725/04 for 571

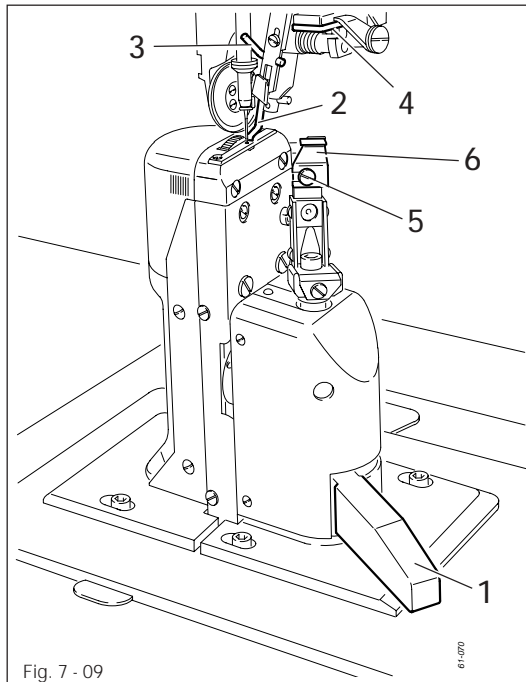

Keep your hands away from the moving knife! Danger of injury!

Switch on knife drive:

- Move lever 1 backwards. The knife moves into operating position.

Switch off knife drive:

- Press lever 1. The knife swings backwards.

Switch on edge guide:

- Swing edge guide 2 into position by hand and press lever 3. The edge guide 2 moves into its operating position.

Switch off edge guide:

- Raise edge guide 2 and let it click into position. The edge guide 2 is out of operation.
- Raise lever 4. The edge guide swings backwards.

Changing the knife:



The following work may only be carried out by technical staff or by persons who have been properly instructed.

- Switch off the machine.
- Loosen screw 5 and remove knife 6.
- Insert new knife and slightly tighten screw 5.
- Adjust the knife according to Chapter 12.05.05 Cutting stroke and tighten screw 5.

7.10 Edge trimmer -725/04 for 574 and 591

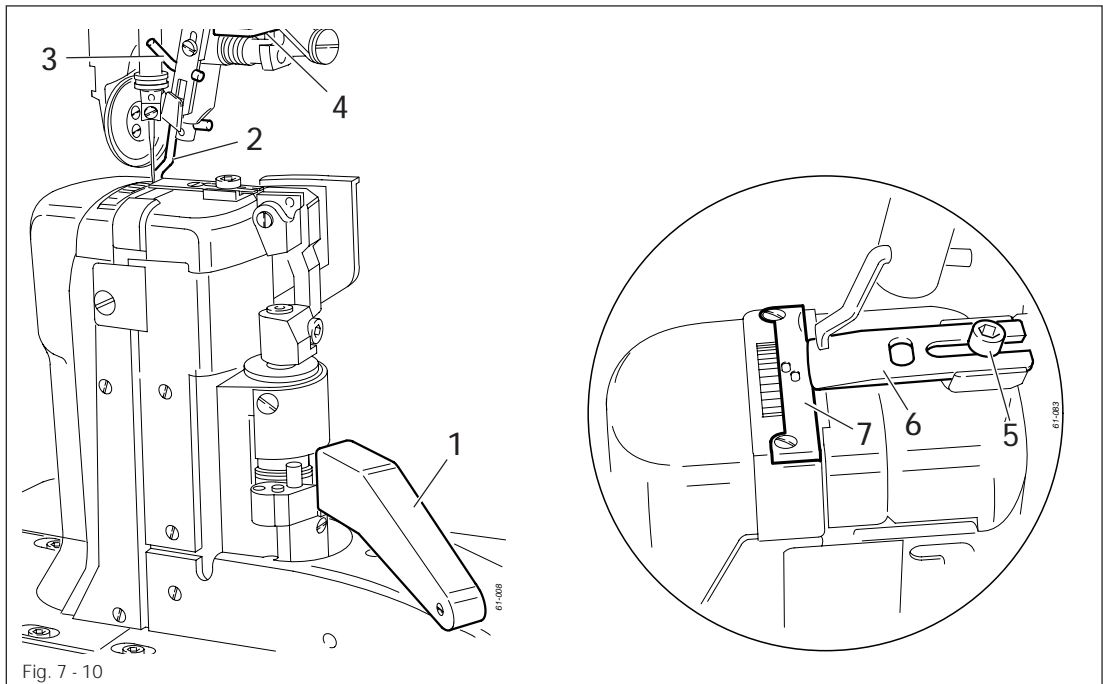

Keep your hands away from the moving knife! Danger of injury!

Switch on knife drive:

- Move lever 1 backwards. The knife moves into operating position.

Switch off knife drive:

- Press lever 1. The knife swings backwards.

Switch on edge guide:

- Swing edge guide 2 into position by hand and press lever 3. The edge guide 2 moves into its operating position.

Switch off edge guide:

- Raise edge guide 2 and let it click into position. The edge guide 2 is out of operation.
- Raise lever 4. The edge guide swings backwards.

Changing the knife:



The following work may only be carried out by technical staff or by persons who have been properly instructed.

- Switch off the machine.
- Loosen screw 5 and remove knife 6.
- Insert new knife and push it close to needle plate insert 7.
- Slightly tighten screw 5.
- Adjust the knife according to Chapter 12.05.07 Knife position and tighten screw 5.

7.11 Edge trimmer -726/05 for 591

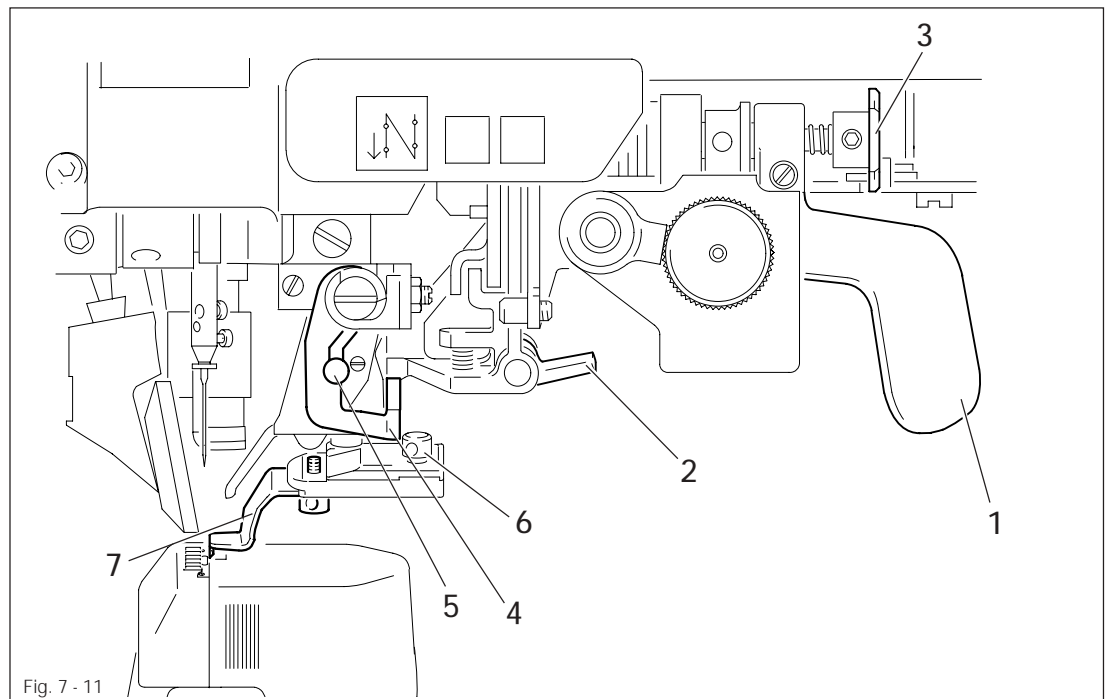

Fig. 7 - 11



Keep your hands away from the moving knife! Danger of injury!

Switch on knife drive:

- By turning lever 1 the knife is moved into its operating position.

Switch off knife drive:

- By pressing lever 2 or key 3 the knife is put out of operation.

Switch on edge guide:

- After lever 4 has been pressed, the edge guide moves into its starting position.

Switch off edge guide:

- By raising lever 5, the edge guide is put out of operation.

Changing the knife:



The following work may only be carried out by technical staff or by persons who have been properly instructed.

- Switch off the machine.
- Loosen screw 6 and remove knife 7.
- Insert new knife and push it close to needle plate insert.
- Tighten screw 6.
- Adjust the knife according to Chapter 12.06.01 Position of the knife to the needle plate and Chapter 11.06.02 Knife crosswise to sewing direction.

7.12 Control panel

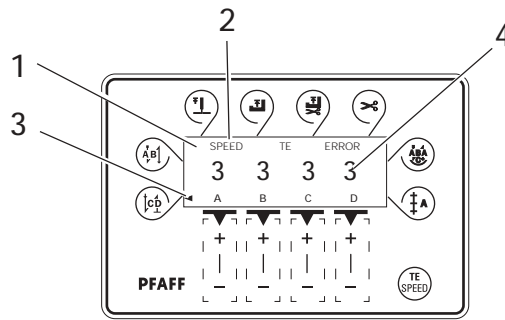

The control panel consists of display 1 and the function keys described below. The display 1 consists of a single-line alpha-numerical, 7 segment LCD display with 8 symbols. The texts 2, located above and next to the LCD display, show the respective status of the function keys and the operating status of the machine. The control panels switches on all LCD-segments and the horn automatically for a short time during the power-on phase, after which the lettering PFAFF appears on the display, until the higher-ranking control unit sends commands to the control panel.

The function keys are located around the display 1. They are foil-packed without permanent marking and without contact signal. Fixed functions are allocated to the keys, see **Chapter 7.12.02 Function keys**.

7.12.01 Screen displays

- Activated functions are displayed with a triangular marking 3 below or next to the respective function key.
- In the sewing mode all relevant sewing data is displayed and can be changed directly, depending on the status of the machine, see also **Chapter 10 Sewing**.
- During the parameter input the selected parameter number with the corresponding value is displayed, see **Chapter 12.09.02 Example of a parameter input**.

7.12.02 Function keys

The function keys described below are used basically to switch machine functions on and off.

Each time a key is pressed, this must be confirmed by at least one beep tone. Irrespective of the machine mode a double beep signal is given if invalid keys are pressed or maximum values reached.



If a corresponding value has to be set for the activated function, this is carried out with the corresponding +/- key. By pressing and holding the corresponding +/- key, the relevant numerical value 4 is changed slowly to begin with. If the corresponding +/- key is held down longer, the values change more quickly.



Start backtacks

- If this key is pressed, the backtacks at the beginning of the seam (start backtacks) are switched on or off. The number of forward stitches (A) or reverse stitches (B) for the start backtacks can be changed by pressing the +/- key underneath. To convert from double backtack to single backtack set the number of stitches for the corresponding seam section at zero.



End backtacks

- If this key is pressed, the backtacks at the end of the seam (end backtacks) are switched on or off. The number of reverse stitches (C) or forward stitches (D) can be changed by pressing the +/- key underneath. To convert from double backtack to single backtack set the number of stitches for the corresponding seam section at zero.



Needle position

- If this key is pressed the „needle raised after sewing stop“ function is switched on or off. When the function is switched on, the needle positions at t.d.c. after sewing stops.



Foot position after stop

- If this key is pressed the „foot raised after sewing stop“ function is switched on or off. When the function is switched on, the presser foot is raised after sewing stops.



Foot position after trimming

- If this key is pressed the „foot raised after thread trimming“ function is switched on or off. When the function is switched on, the presser foot is raised after thread trimming.



Thread trimmer

- If this key is pressed the thread trimming function is switched on or off.



Darning program (this function is mainly used in the textile industry)

- If this key is pressed the darning program function is switched on or off. The counted seam function is switched off automatically.



Counted seam

- If this key is pressed the counted seam function is switched on or off. The darning program function is switched off automatically.



TE/Speed

- If this key is pressed once the speed limit for the sewing mode is activated.
- If this key is pressed twice (within 5 seconds) the machine changes from sewing to input mode.

8 Installation and commissioning



The machine must only be installed and commissioned by qualified personnel!
All relevant safety regulations must be strictly adhered to!



If the machine is delivered without a table, be sure to use a stand and table top that can hold the weight of the machine with its motor.
It is very important to ensure that the stand of the machine is firm and steady, also during sewing.

8.01 Installation

The site where the machine is installed must be provided with suitable connections for electric current.

It must be ensured that the standing surface of the machine site is firm and horizontal, and that sufficient lighting is provided for.



For packing and transportation reasons the table top is in the lowered position.
The table height is adjusted as described below.

8.01.01 Adjusting the table height

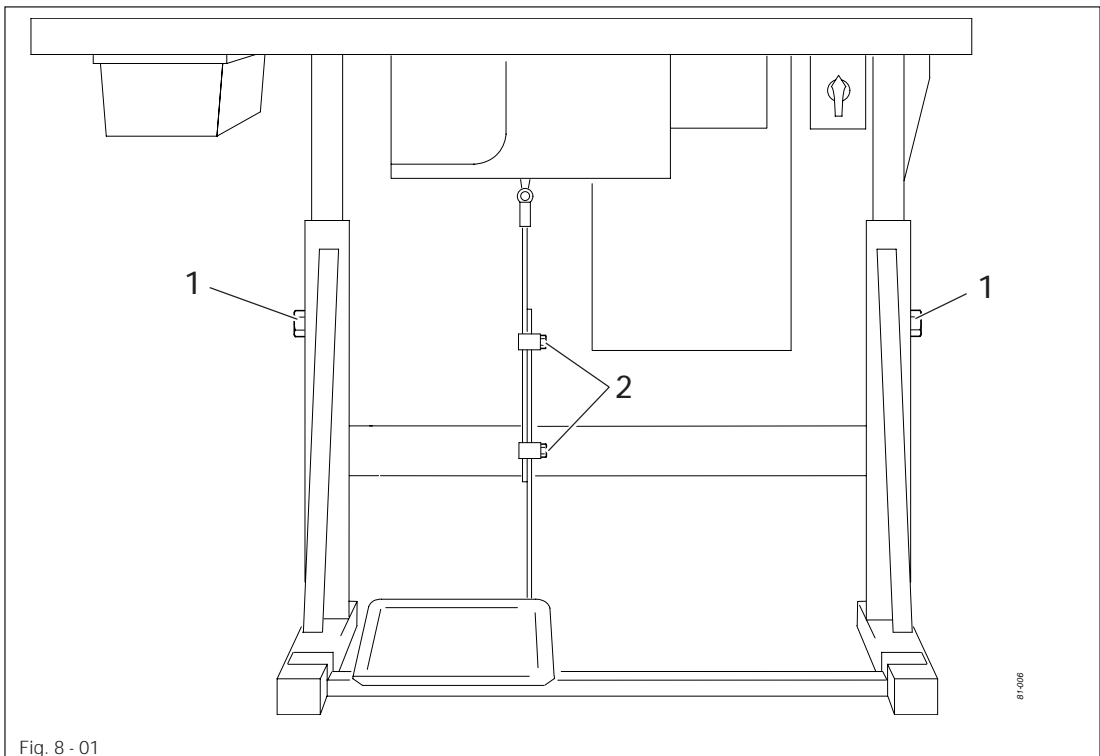

- Loosen screws 1 and 2 and set the table height as required.
- Firmly tighten screw 1.
- Set the required pedal position and tighten screw 2.

8.01.02 Fitting the tilt lock

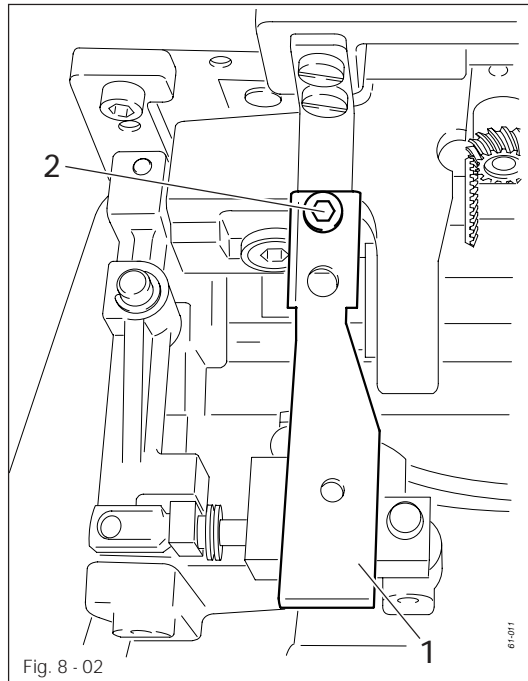

Switch off the machine!
Danger of injury if the machine is started accidentally!

- Screw on the tilt lock 1, provided in the accessories, using screw 2.



Do not operate the machine without tilt lock 1. Danger of crushing between sewing head and table top!

8.01.03 Fitting the machine cover

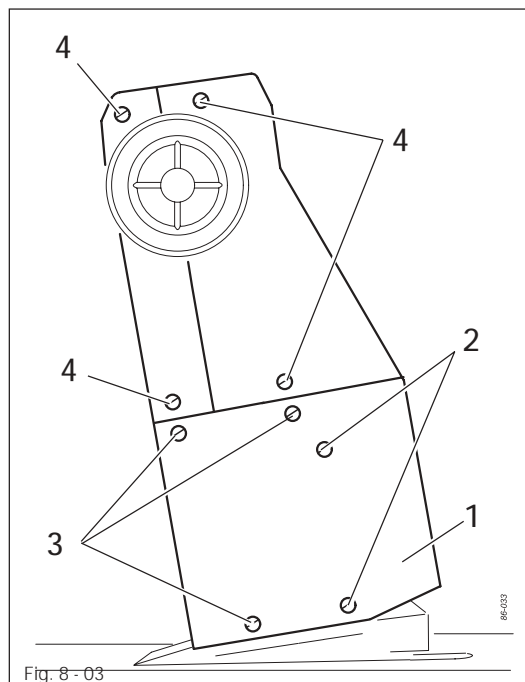

- Slide the slots of the lower section of the cover 1 behind the heads of screws 2 and attach with screws 3, then tighten screws 2 through the holes.
- Attach right and left cover sections with screws 4.

Installation and commissioning

8.02 Mounting the flange motor

8.02.01 Mounting the flange motor to the bearing plate

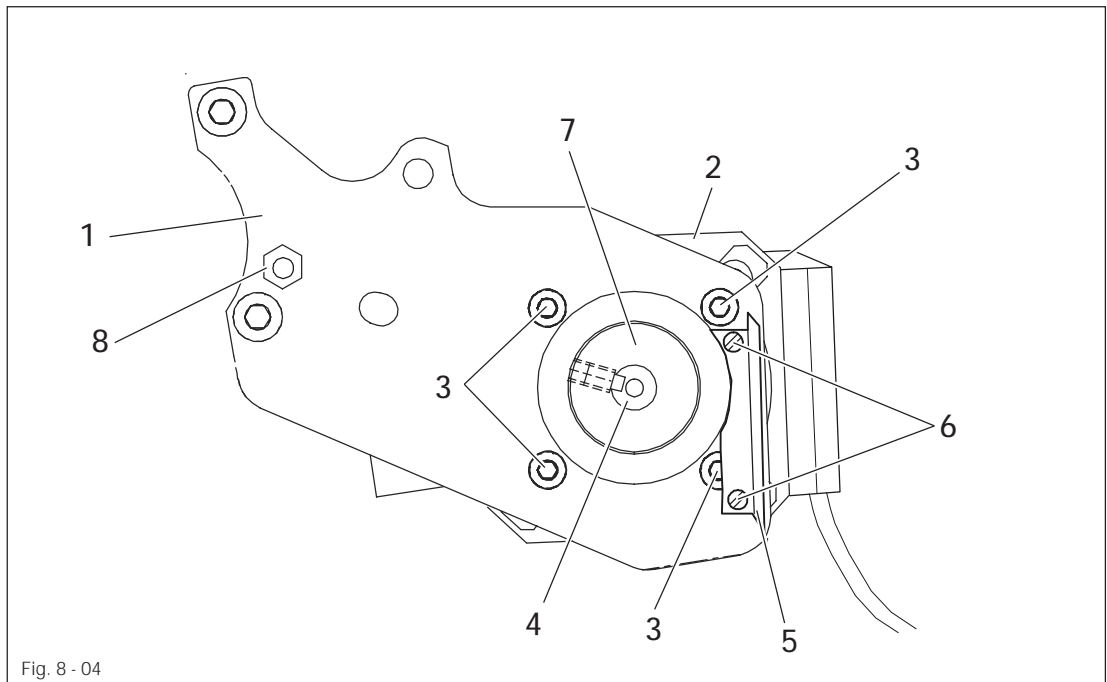

- Attach bearing plate 1 to motor 2 with screws 3 as shown in Fig. 8 - 04.
- Remove the wedge from motor shaft 4.
- Attach angle bracket 5 with screws 6.
- Fit toothed belt wheel 7 to the motor shaft 4, so that the point of the screw is located in the groove of the motor shaft.
- Screw threaded stud 8 into the bearing plate 1.

8.02.02 Mounting the flange motor to the machine

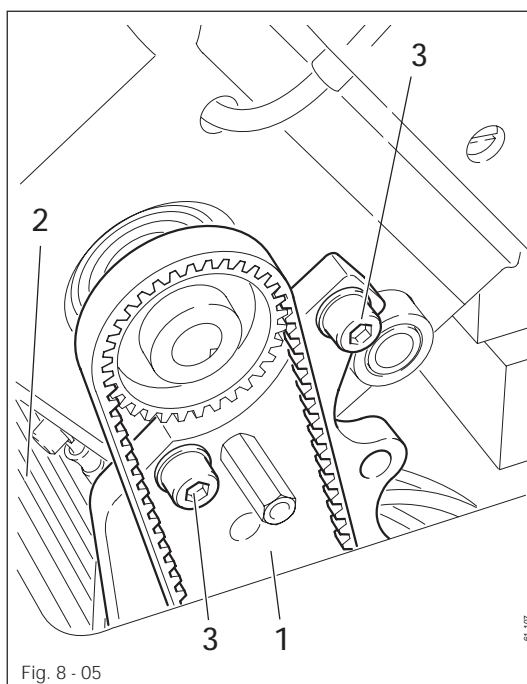

- Attach bearing plate 1 of motor 2 to the machine case with screws 3 (only tighten screws 3 slightly).

8.02.03 Connecting the plug-in connections and earth cables

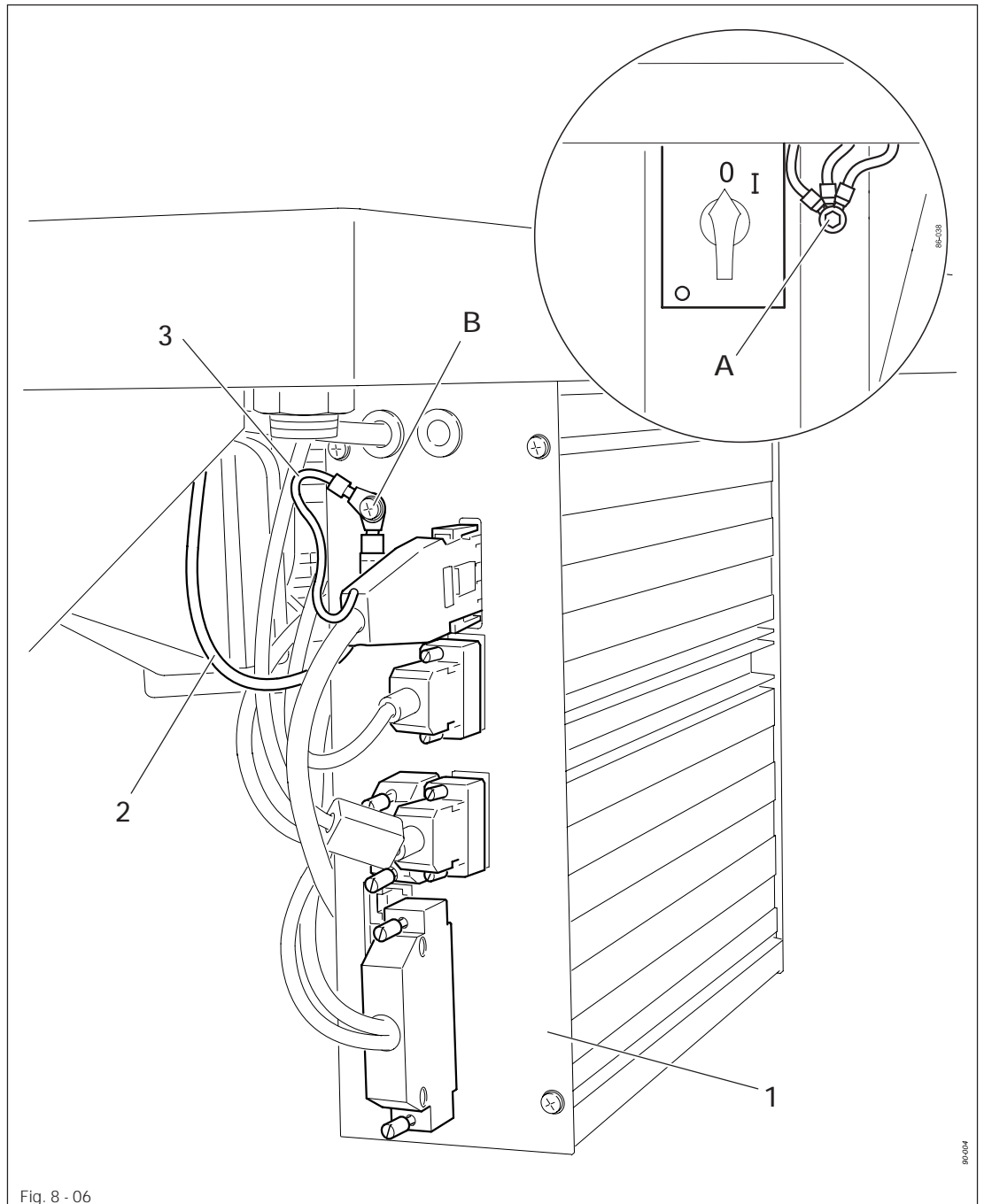

- Connect all plugs as labelled to the control box 1.
- Screw the earth cable from the sewing head and the main switch to earth point A.
- Connect earth point A to earth point B with earth cable 2.
- Screw the earth cable 3 from the motor to earth point B.

8.02.04 Mounting the toothed belt and adjusting the tension

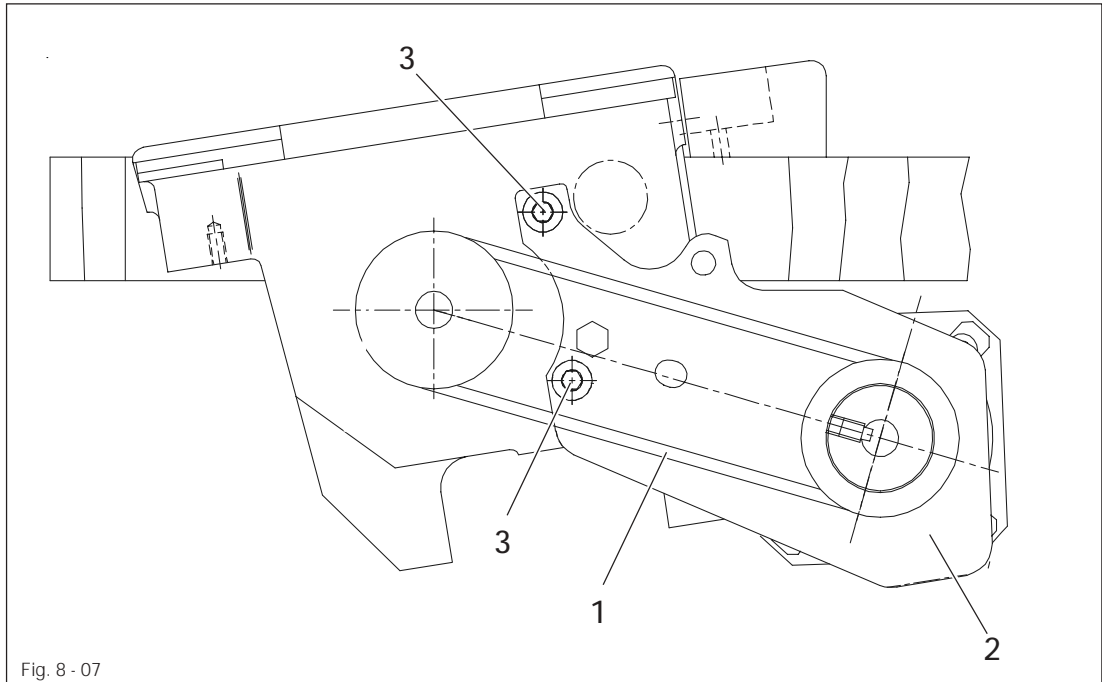

- In this position fit toothed belt 1.
- Swing the bearing plate 2 of the motor, so that the toothed belt is tensioned.
- In this position tighten screws 3.

8.02.05 Mounting the belt guard of the flange motor

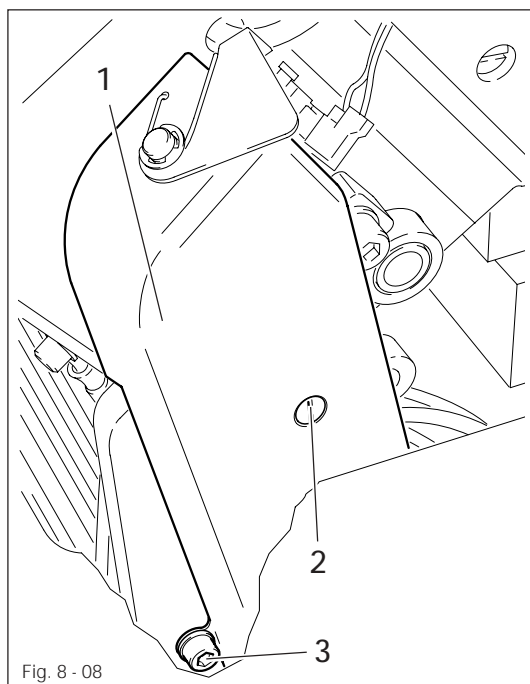

- Attach belt guard 1 with screws 2 and 3.

8.02.06 Connecting the safety switch

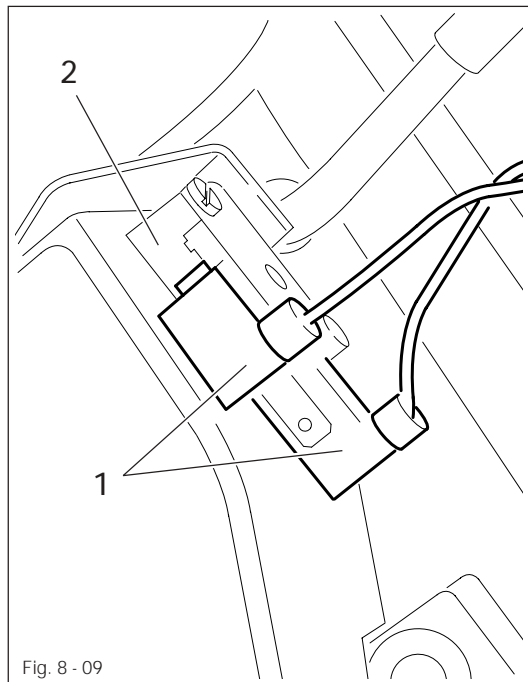

- Connect plug 1 of safety switch 2 as shown in Fig. 8-09.



When the sewing head is tilted back, the safety switch prevents the machine starting when the main switch is on.

8.02.07 Checking the start inhibitor function

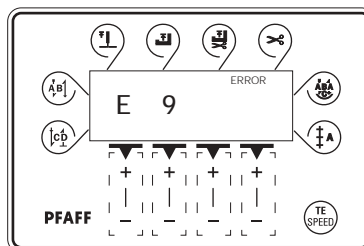

- Switch the machine on at the main switch and tilt back the sewing head. The error message "E9" must appear on the control panel.
- If the message does not appear, check the setting of safety switch 2.
- Set the sewing head upright and acknowledge the error message by pressing the TE/Speed key. The machine is ready for operation again.



8.03 Fitting the reel stand

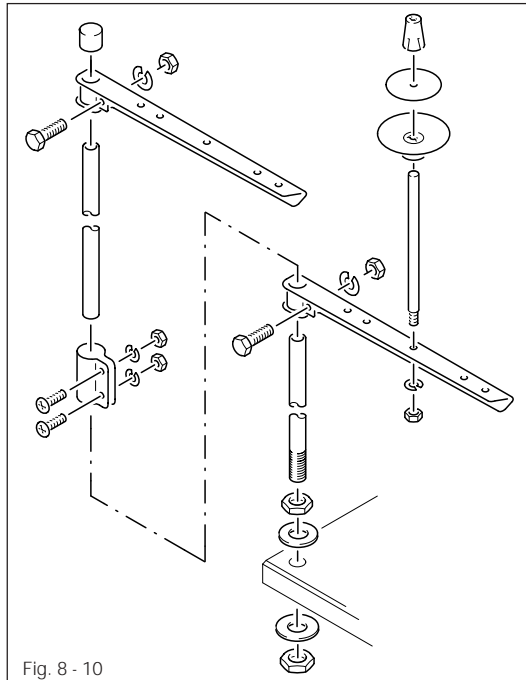

- Fit the reel stand as shown in Fig. 8-04.
- Afterwards insert the stand in the hole in the table top and secure it with the nuts provided.

8.04 Commissioning

- Check the machine, particularly the electrical wiring, for any damage.
- Clean the machine thoroughly and then oil it or fill in oil (see Chapter 11 Care and maintenance).
- Have a mechanic check whether the motor of the machine can be operated with the available power supply, and that the motor is correctly connected in the junction box. If there are any discrepancies the machine **must not be operated under any circumstances**.



The machine may only be connected to an earthed socket!

- When the machine is running, the balance wheel must turn towards the operator. If it does not, have the motor connection changed by a mechanic.
- Machines with pneumatic equipment must be connected to the compressed air supply. The pressure gauge should indicate a pressure of 6 bar. If necessary, adjust to the correct setting (see Chapter 11.07 Checking adjusting the air pressure).

8.05 Switching the machine on/off

- Switch the machine on or off (see Chapter 7.01 On/off switch).

Setting up



All instructions and regulations in this instruction manual must be observed. Special attention must be paid to all safety regulations!



All setting-up work must only be carried out by personnel with the appropriate training. For all setting-up work the machine must be disconnected from its power supply by turning off the on/off switch, or removing the plug from the electric power socket.

9.01

Inserting the needle on model 571 and 591

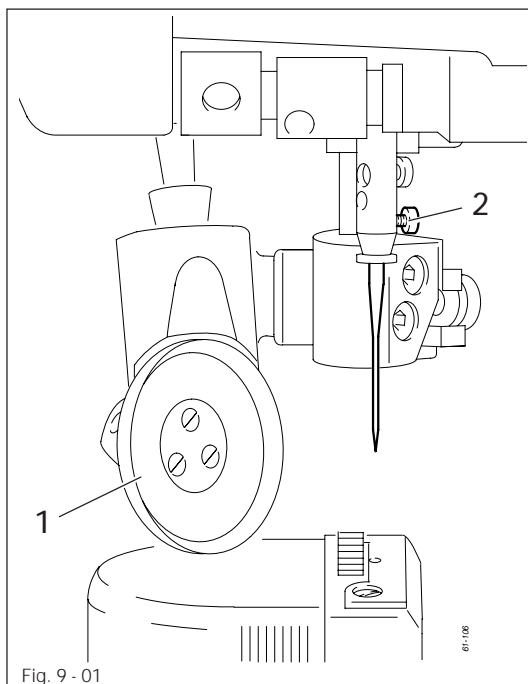

Switch the machine off!
Danger of injury if the machine is started accidentally!

Only use needles of system 134.

- Raise the roller presser 1 and swing it out.
- Loosen screw 2 and insert the needle as far as possible. The long groove must face to the right on model 571 and to the left on model 591.
- Tighten screw 2 and swing roller presser 1 back into position.



The choice of needle depends on the model of the machine and the thread and material used (see Chapter 3.02 Needles and threads).

9.02 Inserting the needle on model 574

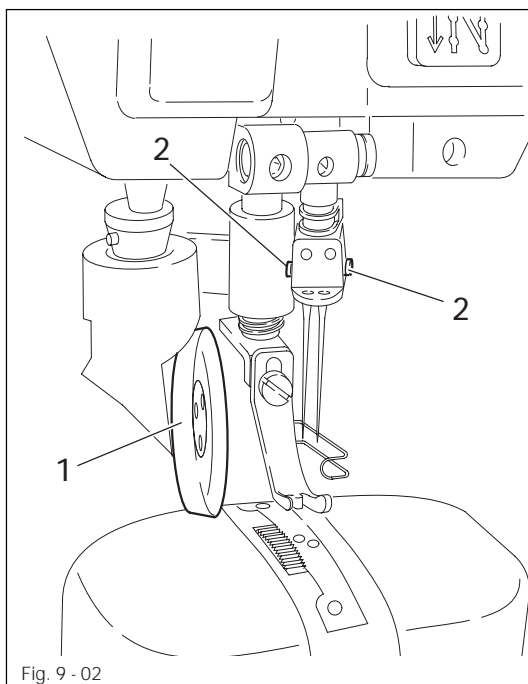

Switch the machine off!
 Danger of injury if the machine
 is started accidentally!

Only use needles of system 134-35.

- Raise the roller presser 1 and swing it out.
- Loosen screws 2 and insert the needles so that the long groove of the left needle is facing right, and that of the right needle is facing left.
- Tighten screws 2 and swing roller presser 1 back into position.



The choice of needle depends on the model of the machine and the thread and material used (see Chapter 3.02 Needles and threads).

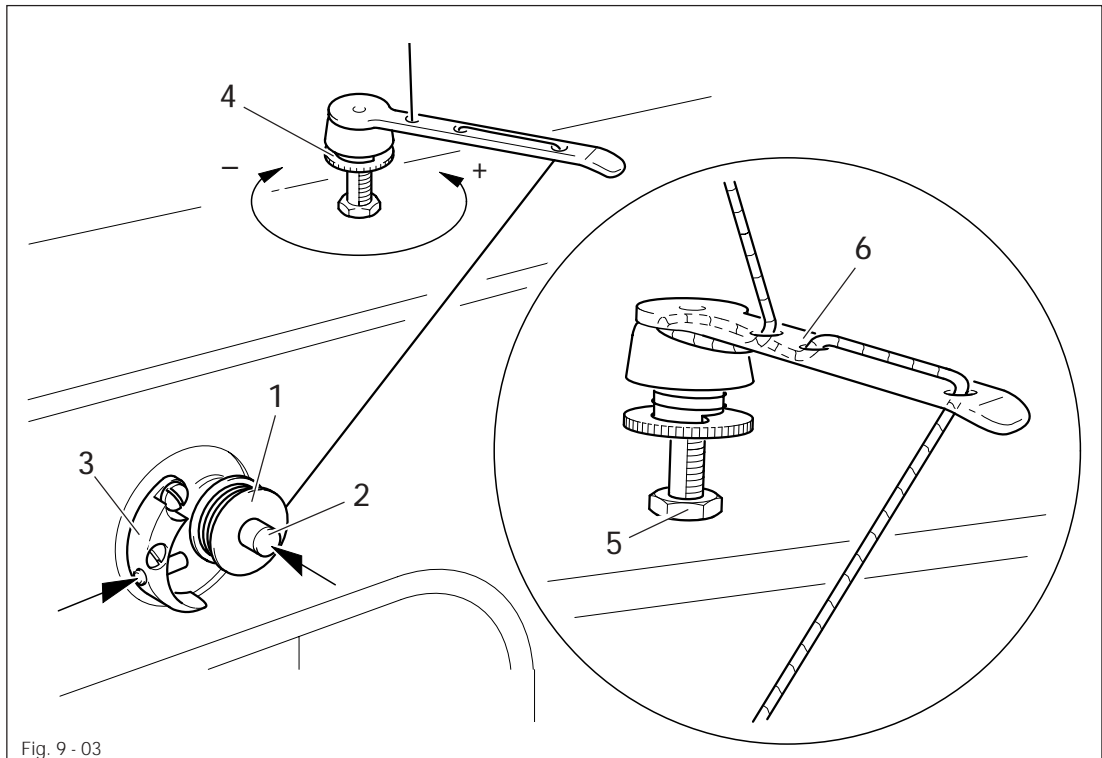

Fig. 9 - 03

- Place an empty bobbin 1 onto bobbin winder spindle 2.
- Thread the bobbin as shown in Fig. 9 - 03 and wind it clockwise around bobbin 1 a few times.
- Switch on the bobbin winder while at the same time pressing bobbin winder spindle 2 and lever 3.



The bobbin is filled up during sewing.

- The thread tension on bobbin 1 can be adjusted using knurled screw 4.
- The bobbin winder stops automatically when bobbin 1 is full.

If the thread is wound unevenly:

- Loosen nut 5.
- Turn thread guide 6 accordingly.
- Tighten nut 5.

9.04 Removing/Inserting the bobbin case

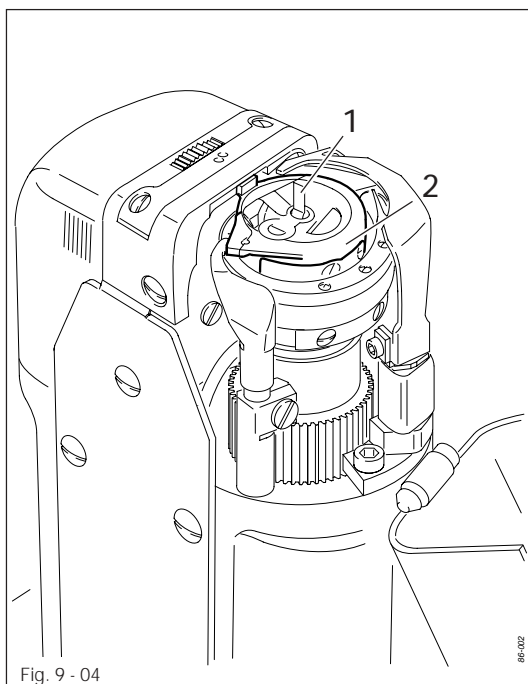

Switch the machine off!
 Danger of injury if the machine is started accidentally!

Removing the bobbin case:

- Open the post cap.
- Raise latch 1 and remove bobbin case 2.

Inserting the bobbin case:

- Insert bobbin case 2.
- Close the latch and close the post cap.



574 is shown in Fig. 9 - 04.

9.05 Threading the bobbin case/Adjusting the bobbin thread tension

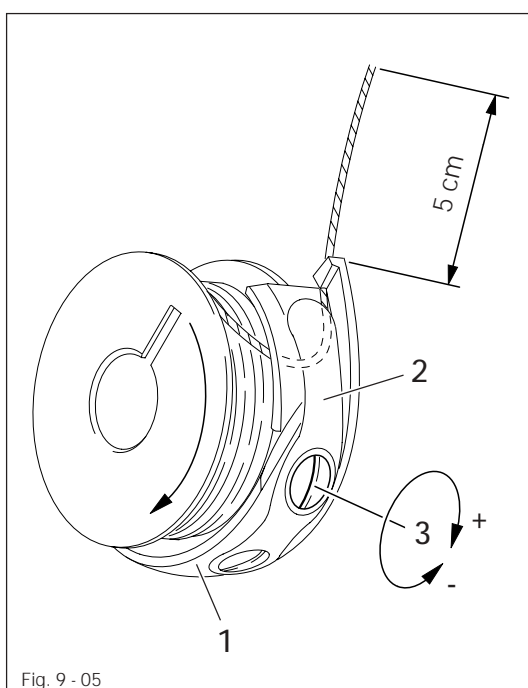

- Insert the bobbin into the bobbin case 1.
- Pass the thread through the slot under spring 2.
- Pass the thread through the notch.
- Adjust the thread tension by turning screw 3.



When the thread is pulled, the bobbin must rotate in the direction of the arrow.

9.06 Threading the needle thread and regulating its tension on model 571 and 591

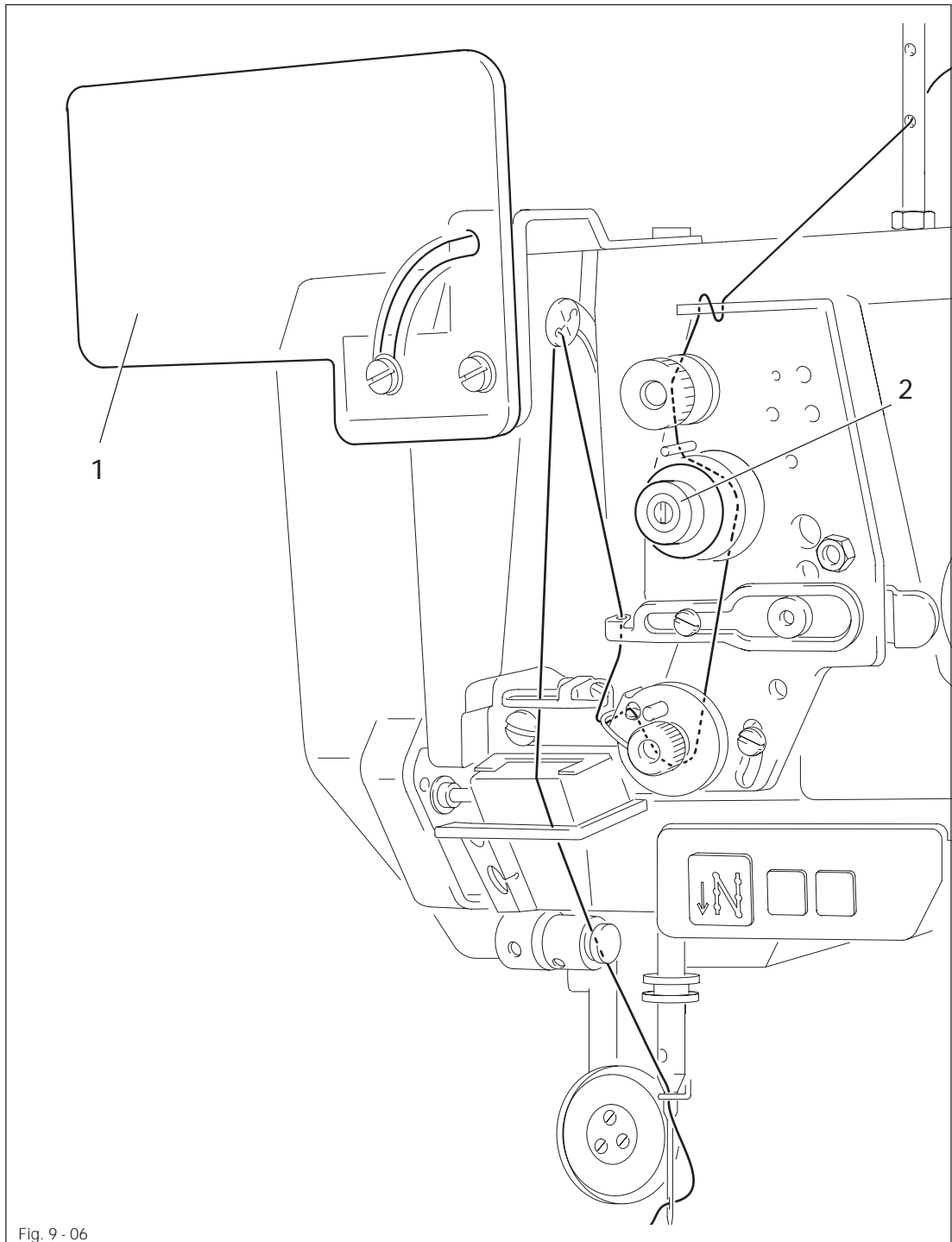

Fig. 9 - 06



Switch the machine off!
Danger of injury if the machine is started accidentally!

- Tilt up the eye guard 1.
- Thread the needle thread as shown in Fig. 9-06.
- On model 571 the needle is threaded from the right to the left, and on model 591 from the left to the right.
- Adjust the needle thread tension by turning milled screw 2.

9.07

Threading the needle thread and regulating its tension on model 574

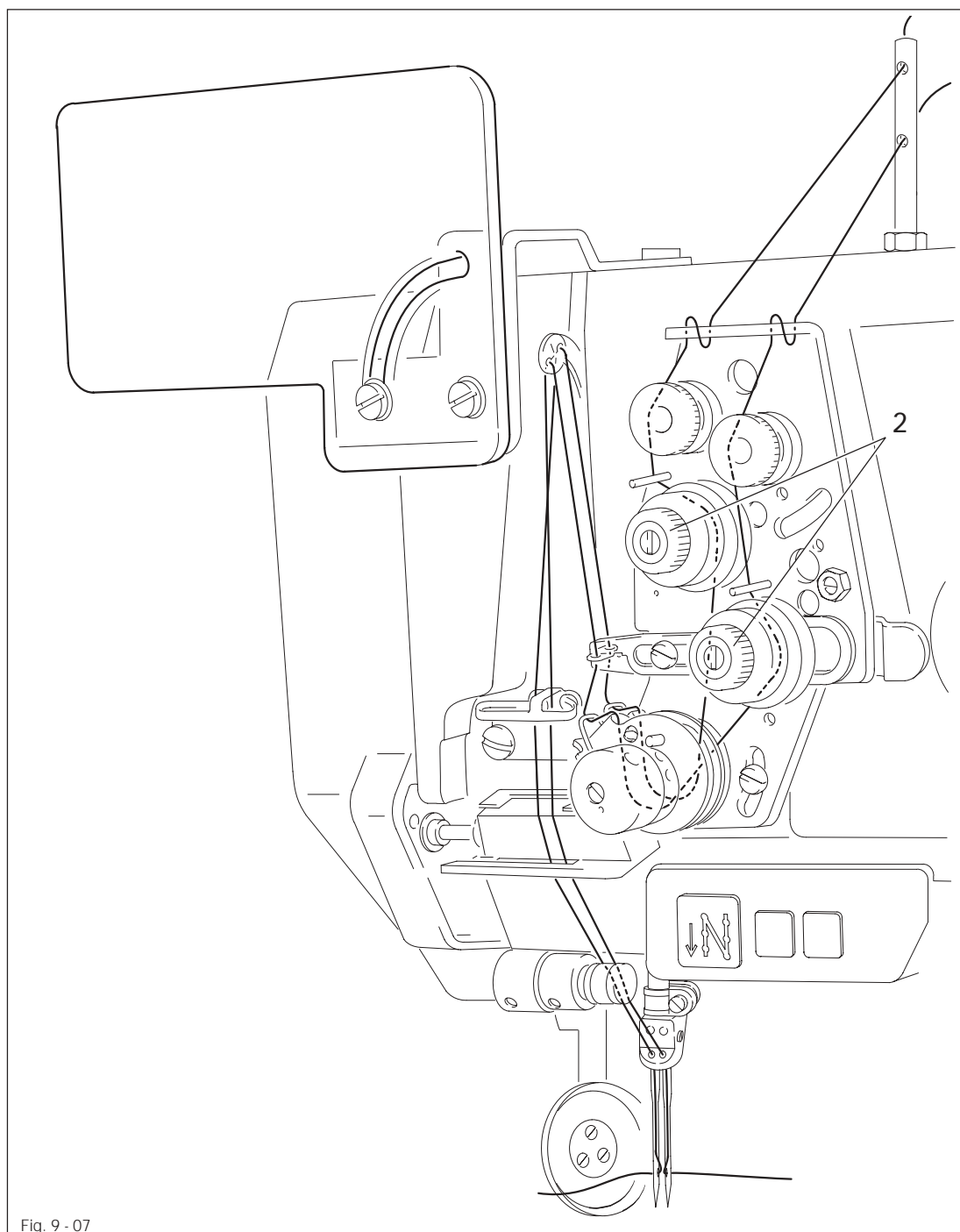

Fig. 9 - 07



Switch the machine off!
 Danger of injury if the machine is started accidentally!

- Tilt up the eye guard 1.
- Thread both needle threads as shown in Fig. 9-07.
- The left needle is threaded from the right to the left, and the right needle from the left to the right.
- Adjust the needle thread tensions by turning milled screws 2.

9.08 Setting the stitch length

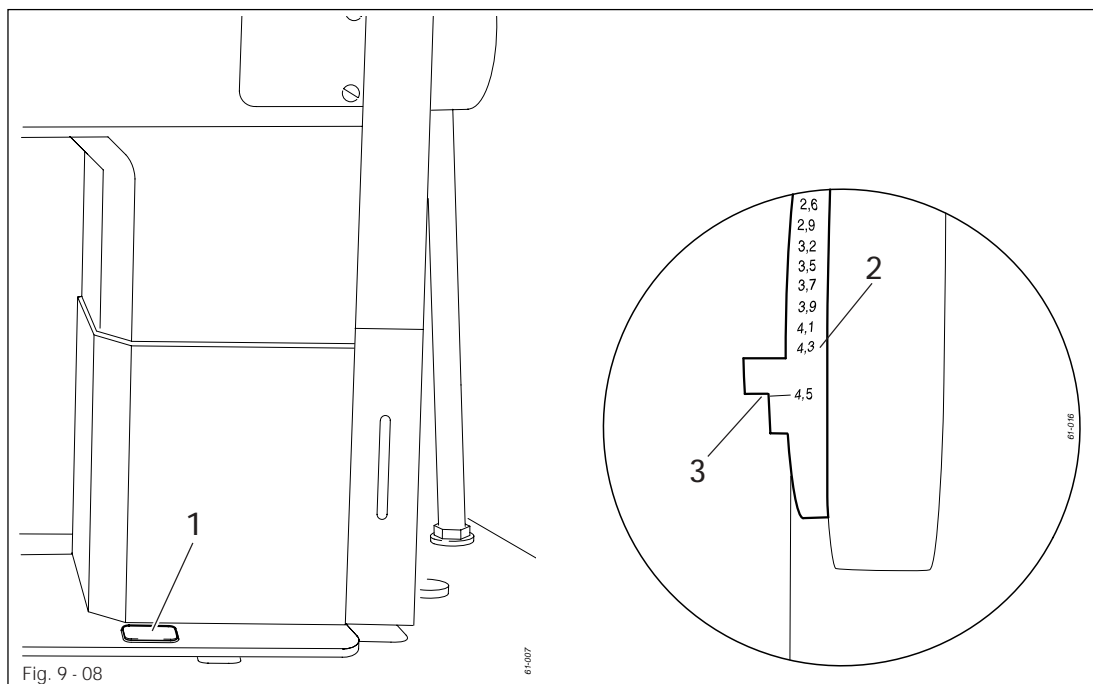

- Press key 1 and at the same time turn the balance wheel until the stitch setter clicks into position.
- Hold down key 1 and turn the balance wheel to and fro until the stitch length required is shown on the scale 2 opposite the bottom edge 3 of the belt guard recess.

9.09 Entering the start and end backtacks

- Switch on the machine.

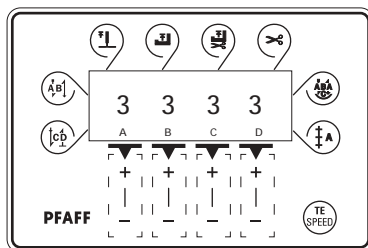

- If necessary switch off the "darning seam" or "counted seam" function, see Chapter 10.01 Darning program or Chapter 10.02 Counted seam.
- By pressing the corresponding +/- key ("A") select the desired value for the number of forward stitches (A) of the start backtack.
- By pressing the corresponding +/- key ("B") select the desired value for the number of reverse stitches (B) of the start backtack.
- By pressing the corresponding +/- key ("C") select the desired value for the number of reverse stitches (C) of the end backtack.
- By pressing the corresponding +/- key ("D") select the desired value for the number of forward stitches (D) of the end backtack.



- By pressing the keys **start backtack** and/or **end backtack**, activate the corresponding function (arrow appears next to the corresponding function key).

9.10 Setting the stitch count function for the bobbin thread control

- Switch on the machine.

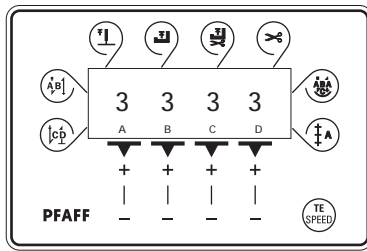

- 2 x  ● Press the TE/Speed key twice to call up the parameter input function.

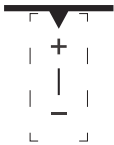
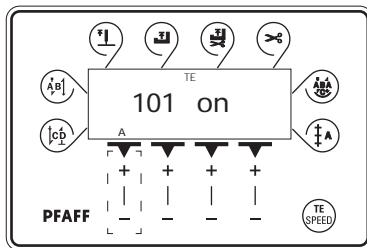

- Call up parameter "798" and select the technician level B, see Chapter 12.09.01 Selecting the user level.

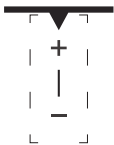

- By pressing the corresponding +/- key select the parameter "760".

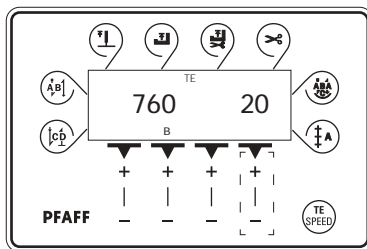

- By pressing the corresponding +/- key set the number of stitches to be sewn with one bobbin.
The selected value is multiplied by 200 and the result is the number of stitches.
Example display 20 x 200 = 4000 stitches.



- Store the input by ending the parameter input function.

10 Sewing

In the sewing mode all relevant settings for the sewing operation are displayed. Functions can be switched on or off by pressing a key. Values for start and end backtacks or stitch placement can be changed directly.



When the machine is switched on, the sewing mode is always activated.

- Switch on the machine.

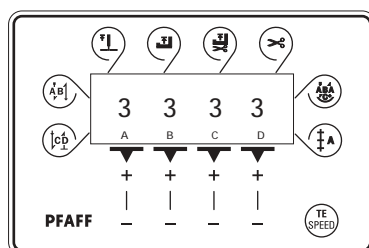

- If necessary switch off the function "darning seam" or "counted seam", see [Chapter 10.01 Darning program](#) or [Chapter 10.02 Counted seam](#).

Functions in manual sewing, also see [Chapter 7.12.02 Function keys](#):



Start backtacks on/off



Presser foot raised at end of seam on/off



End backtacks on/off



Thread trimming on/off



Needle position raised on/off



Darning program on/off



Presser foot raised on/off



Counted seam on/off

Sewing is carried out with the pedal functions, see [Chapter 7.04 Pedal](#).



The "Darning program" and "Counted seam" functions are explained in more detail in [Chapter 10.01 Darning program](#) or [Chapter 10.02 Counted seam](#).

10.01 Darning program (this function is used mainly in the textile industry)

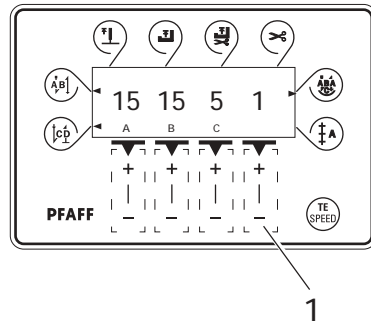

The corresponding function can be switched on or off directly with the **Darning program** key. The "counted seam" function is switched off automatically. Several darning programs with different seam sections A and/or B can be selected. The number of required darning programs can be selected by operating the **+/- key 1**. The number of stitches for the individual seam sections A and/or B can be selected by operating the **corresponding +/- key**. By operating the **corresponding +/- key** it is possible to select a repeating factor "C" for the selected darning program.

If the backtack functions are also activated, only the status backtack on or backtack off is displayed. The individual backtack parameters can be altered after the "darning program" function has been switched off, see **Chapter 9.09 Entering start and end backtacks**.

10.02 Counted seam

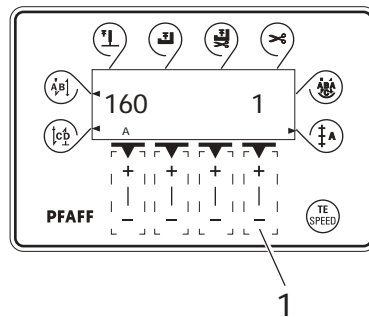

The corresponding function can be switched on or off directly with the **Counted seam** key. The "darning program" function is switched off automatically. Several counted seam sections can be selected. The number of required seam sections can be selected by operating the **+/- key 1**. The required number of stitches "A" of the selected seam section can be selected by operating the **corresponding +/- key**.

If the backtack functions are also activated, only the status backtack on or backtack off is displayed. The individual backtack parameters can be altered after the "counted seam" function has been switched off, see **Chapter 9.09 Entering start and end backtacks**.

11 Care and maintenance

Clean	daily, more frequently if in continuous operation
Oil level (thread lubrication/hook lubrication)	daily, before use
Oil the hook	daily, before use
Lubricate the bevel gears	once a year
Check/adjust air pressure	daily, before use
Clean air filter of air-filter/lubricator	when required



These maintenance intervals are calculated for the average running time of a single shift operation. If the machine is operated more than this, shorter intervals are recommended.

11.01 Cleaning

Clean the hook, hook compartment and toothed wheel 3 daily, several times if in continuous use.

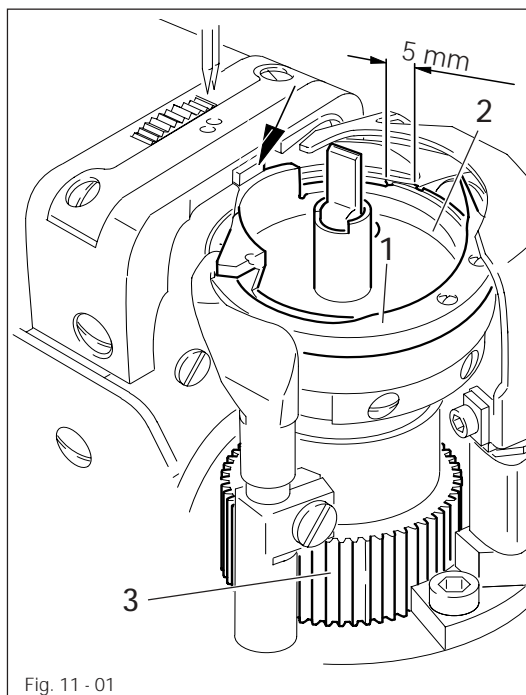

Switch the machine off!
Danger of injury if the machine is started accidentally!

- Bring the needle bar to its highest position.
- Open the post cap and remove the bobbin case cap and the bobbin.
- Unscrew hook grib 1.
- Turn the handwheel until the point of bobbin case 2 penetrates into the groove of the hook race approx. 5 mm.
- Remove bobbin case 2.
- Clean the hook race with paraffin.
- When inserting the bobbin case 2, ensure that the horn of the bobbin case 2 engages in the groove of the needle plate.
- Screw hook grib 1 back on and close the post cap.

11.02 Oiling the hook

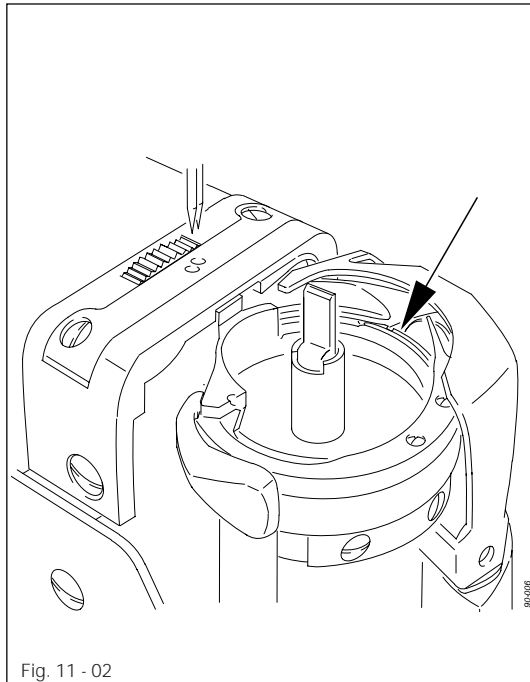

Switch the machine off!
Danger of injury if the machine is started accidentally!

- Pour **1-2 drops** of oil into hole **1** of the hook gib daily.
- Before commissioning the machine, and after long periods out of operation, pour a few drops of oil into the hook race (see arrow).

11.03 Oil bowl for hook lubrication

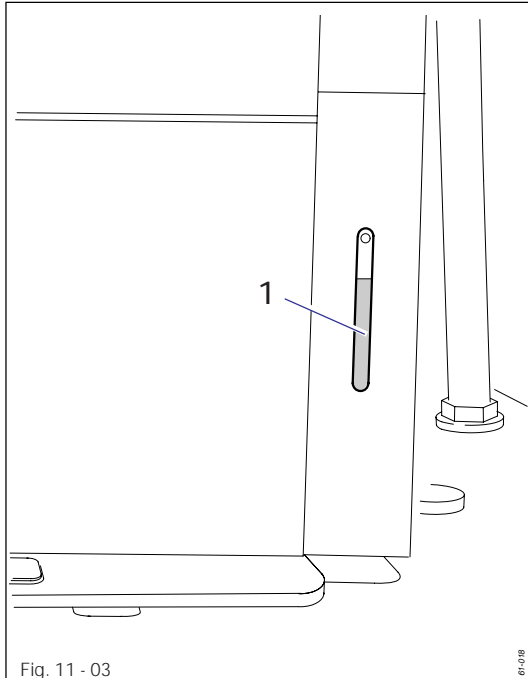

Check the oil level before each use.
There must always be oil in reservoir **1**.

- If required refill oil through hole.



Use only oil with a mean viscosity of $22.0 \text{ mm}^2/\text{s}$ at 40°C and a density of $0.865 \text{ g}/\text{cm}^3$ at 15°C .

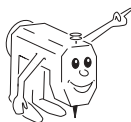

We recommend PFAFF sewing machine oil Best.-Nr. 280-1-120 144.

11.04 Filling the oil reservoir of the thread lubrication unit

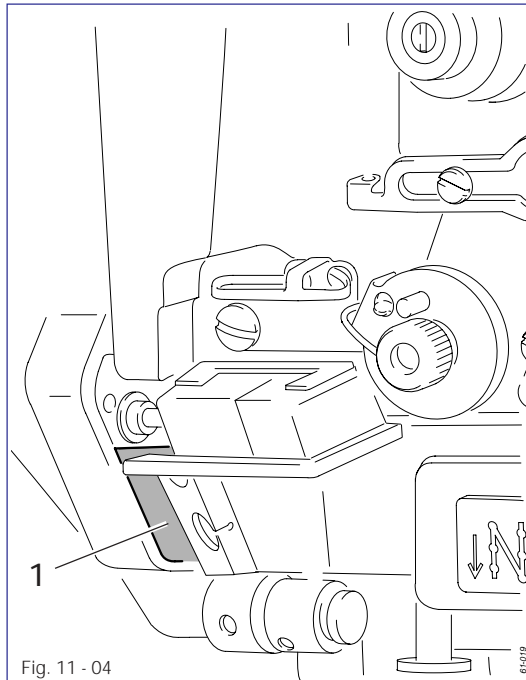

Fig. 11 - 04



Control the oil level before each use.

There must always be oil in the reservoir 1.

- If necessary, fill oil up to mark through hole.

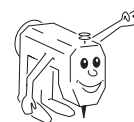

We recommend PFAFF thread lubricating oil, Order No. 280-1-120 217.

11.05 Oiling the edge trimmer -726/05

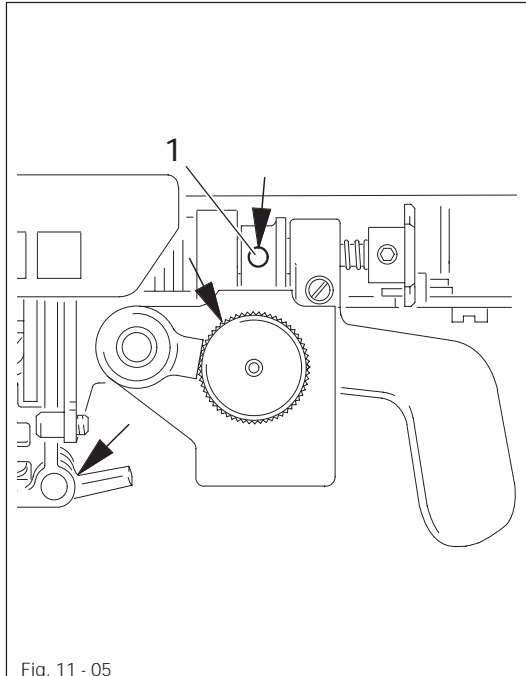
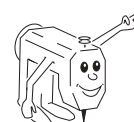

Fig. 11 - 05

- All moving parts and bearings marked with arrows in Fig. 11-05 are to be supplied with oil twice a week.



Use only oil with a mean viscosity of 22.0 mm²/s at 40°C and a density of 0.865 g/cm³ at 15°C.



We recommend PFAFF sewing machine oil Best.-Nr. 280-1-120 144.

11.06 Lubricating the bevel gears

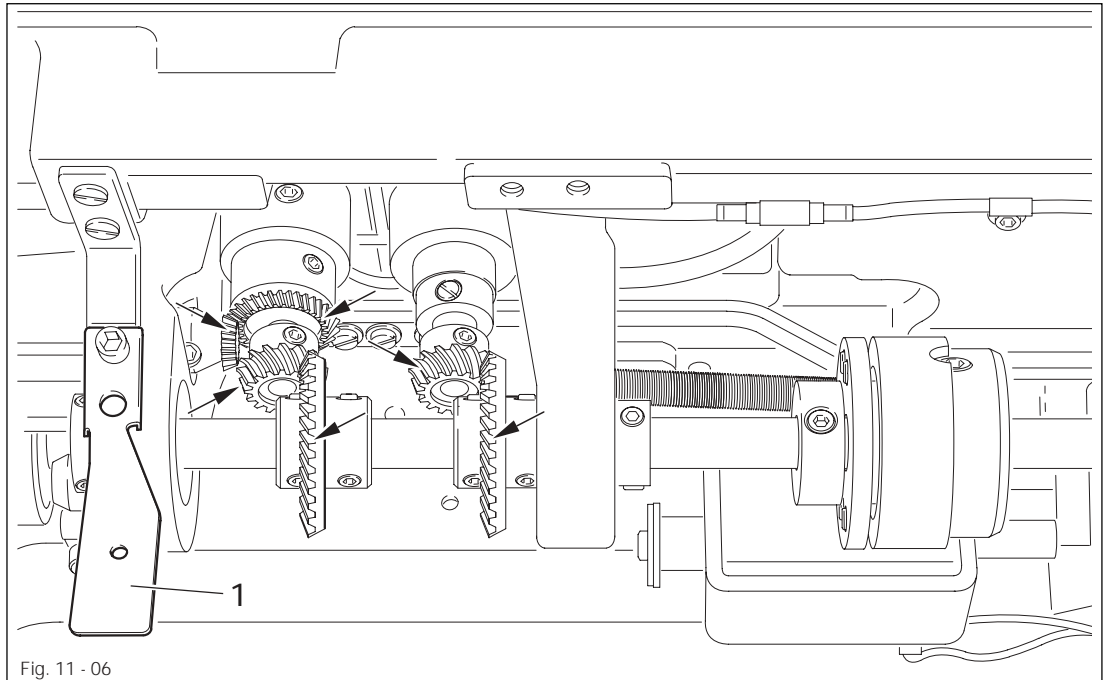

Switch the machine off!
Danger of injury if the machine is started accidentally!

- All bevel gears must be supplied with new grease once a year.
- Tilt the sewing head back onto the support.

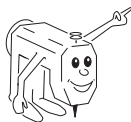

Fig. 11-06 shows the bevel gears of the 574.

- Apply grease to all the tooth flanks and the rack (see arrows).
- To set the sewing head upright, press tilt lock 1 backwards and set the sewing head upright using both hands.



Use both hands to set the sewing head upright!
Danger of crushing between the sewing head and the table top!



We recommend PFAFF sodium grease with a dripping point of approx. 150C,
Order No. 280-1-120 243.

11.07 Checking/adjusting the air pressure

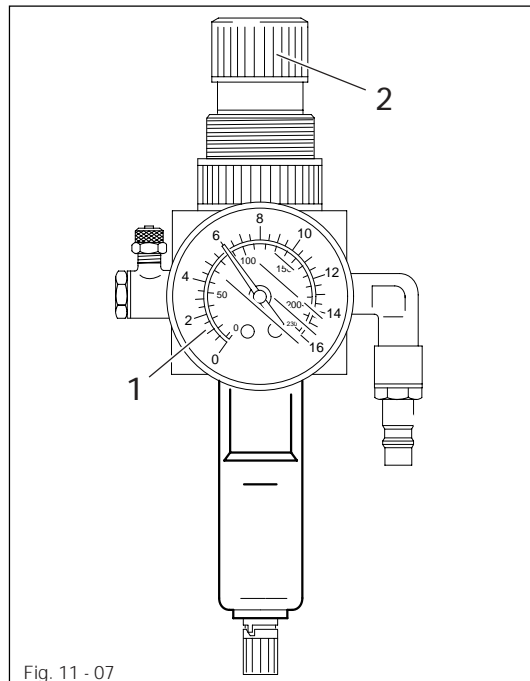

Fig. 11 - 07

- Before operating the machine, always check the air pressure on gauge 1.
- Gauge 1 must show a pressure of 6 bar.
- If necessary adjust to this reading.
- To do so, pull knob 2 upwards and turn it so that the gauge shows a pressure of 6 bar.

11.08 Cleaning the air filter of the air-filter/lubricator

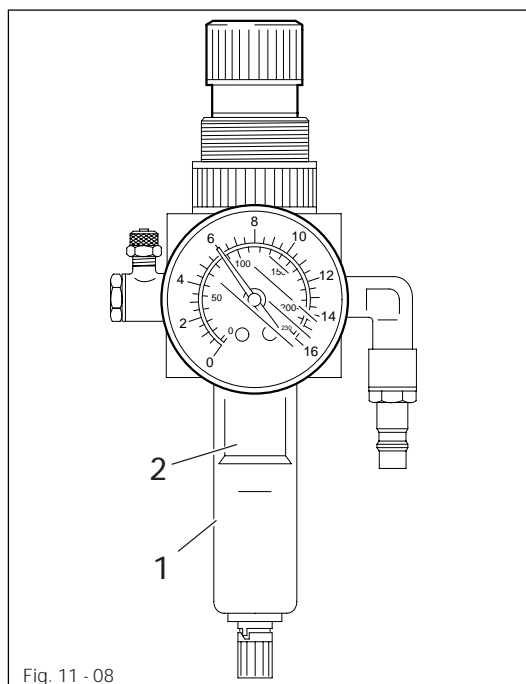

Fig. 11 - 08



Switch the machine off!
Disconnect the air hose at the air-filter/lubricator.

To drain water bowl 1:

- Water bowl 1 drains itself automatically when the compressed-air hose is disconnected from the air-filter/lubricator.

Cleaning filter 2:

- Unscrew water bowl 1.
- Take out filter 2.
- Clean filter 2 with compressed air or isopropyl alcohol (part No. 95-665 735-91).
- Screw in filter 2 and screw on water bowl 1.

12 Adjustment



Unless stated otherwise, during all adjustment work the machine must be disconnected from the electric and pneumatic power supply!
Danger of injury if the machine is started accidentally!

12.01 Notes on adjustment

All following adjustments are based on a fully assembled machine and may only be carried out by expert staff trained for this purpose.

Machine covers, which have to be removed and replaced to carry out checks and adjustments, are not mentioned in the text.

The order of the following chapters corresponds to the most logical work sequence for machines which have to be completely adjusted. If only specific individual work steps are carried out, both the preceding and following chapters must be observed.

Screws, nuts indicated in brackets () are fastenings for machine parts, which must be loosened before adjustment and tightened again afterwards.

12.02 Tools, gauges and other accessories

- 1 set of screwdrivers with blade widths from 2 to 10 mm
- 1 set of open-ended wrenches with opening sizes from 7 to 13 mm
- 1 set of allen keys from 1.5 to 6 mm
- 1 clamp (Order No. 08-880 137-00)
- 1 metal rule (Order No. 08-880 218-00)
- 1 gauge (Order No. 08-880 136-01)
- Sewing thread and test material

12.03 Abbreviations

TDC = top dead center

BDC = bottom dead center

12.04 Adjusting the basic machine

12.04.01 Needle position in sewing direction on the PFAFF 571 and 591

Requirement

With the stitch length set at its minimum, the needle should be positioned in the centre of the needle hole, as seen in the direction of sewing.

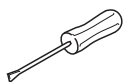
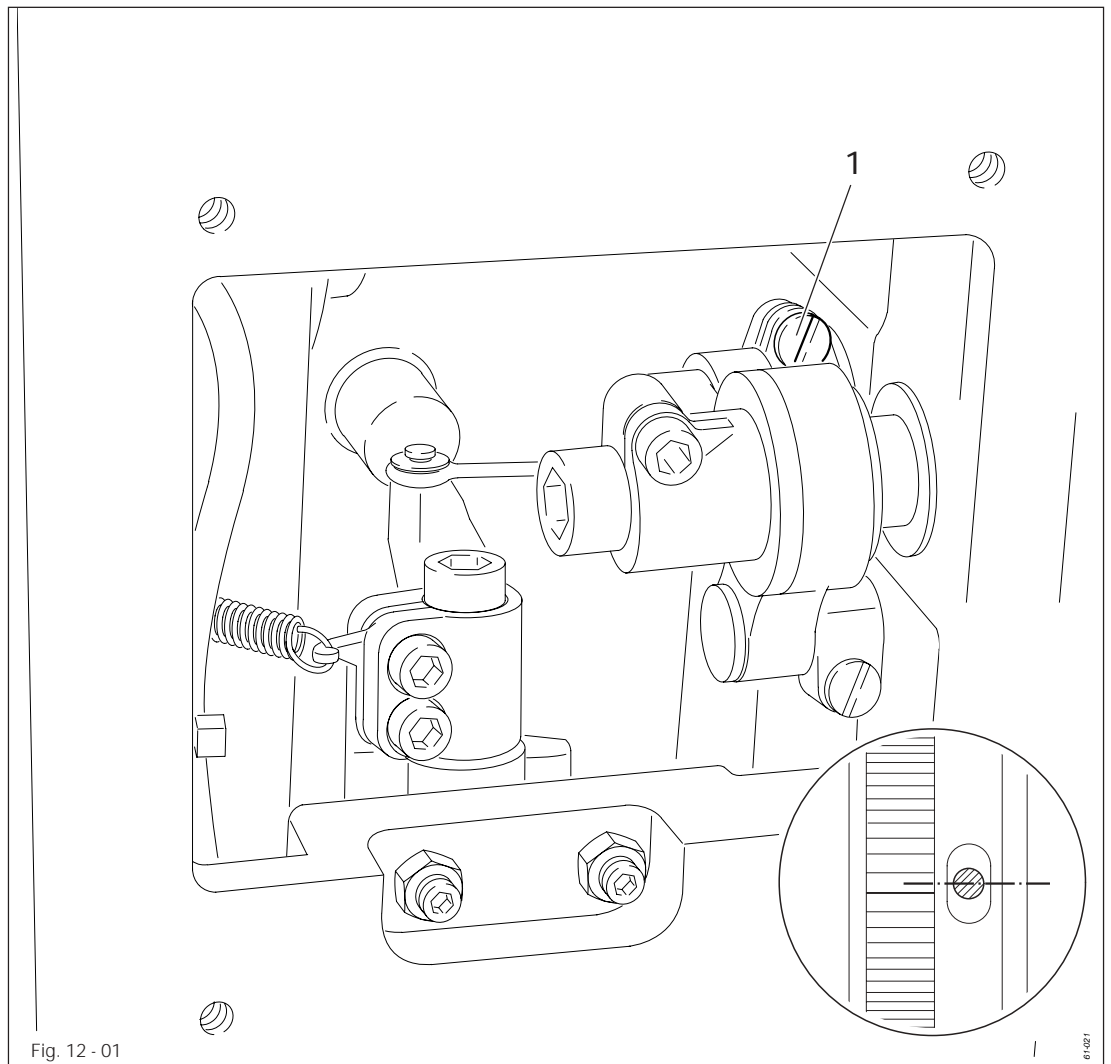

- Set the minimum stitch length.
- Adjust needle bar (screw 1) according to the requirement.

Adjustment

12.04.02 Needle position in sewing direction on the PFAFF 574

Requirement

The needle should be positioned in the centre of the needle hole as seen in the direction of sewing.

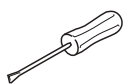
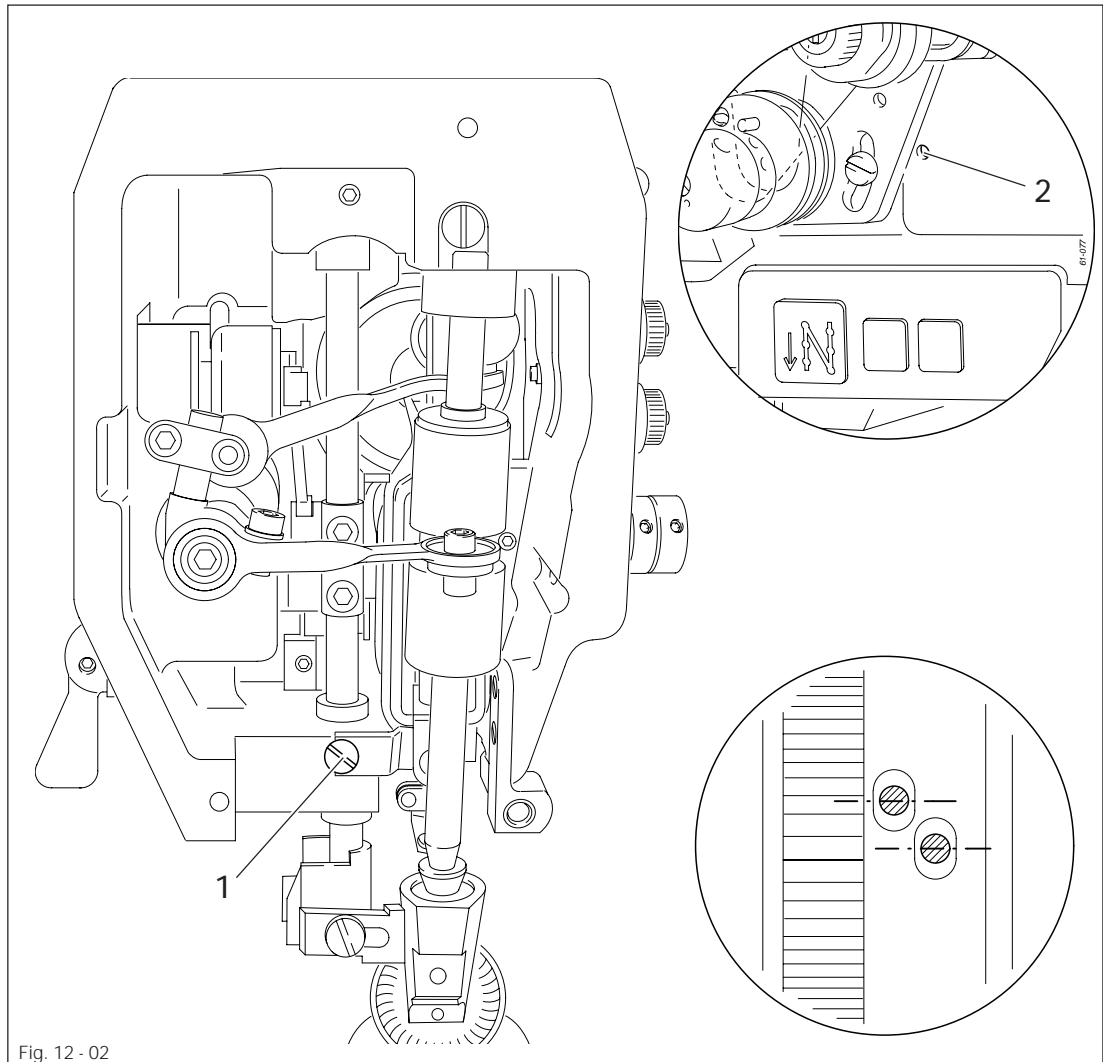

- Adjust needle bar (screws 1 and 2) according to the requirement.

12.04.03 Preliminary adjustment of the needle height

Requirement

When the needle bar is at TDC, there must be a clearance of approx. 21 mm between the needle point and the needle plate.

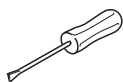
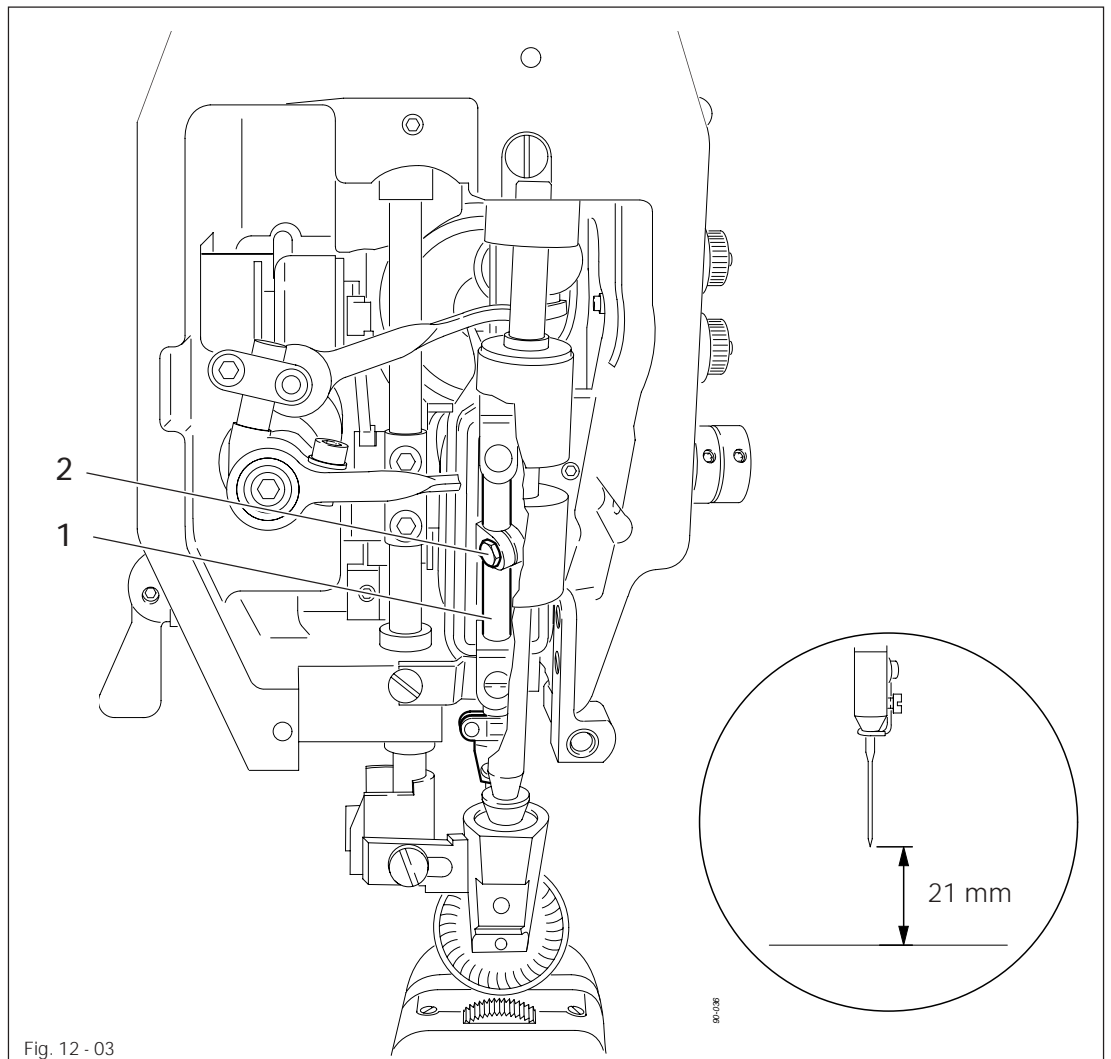

- Adjust needle bar 1 (screw 2), without turning it, according to the requirement.

12.04.04 Needle rise, hook clearance, needle height and needle guard on the PFAFF 571

Requirement

With the needle bar positioned 2,0 mm after BDC and the stitch length set at "0.8"

1. the hook point must be at needle centre with a hook-to-needle clearance of 0.05 to 0.1 mm;
2. the top of the needle eye must be 0.8 to 1.0 mm below the hook point;
3. the needle guard 6 must touch the needle lightly.

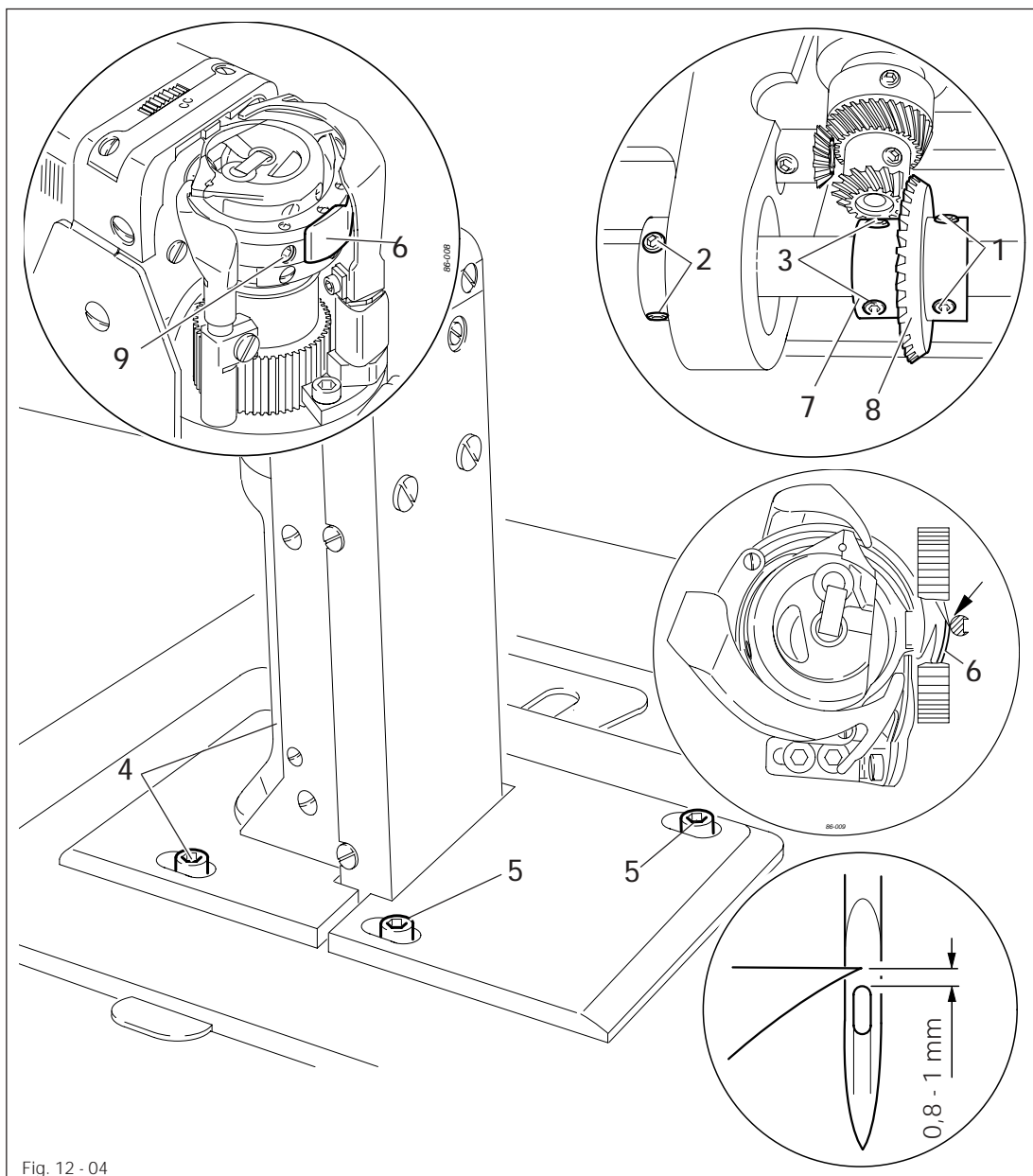
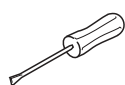

Fig. 12 - 04



- Set stitch length at "0.8".
- Loosen both screws 1, 2, 3, 4 and 5.
- Bring needle bar to 2.0 mm past BDC:
- Set hook point at needle centre, making sure that the needle is not deflected by needle guard 6.
- Adjust needle height according to Requirement 2.

- Adjust hook post according to **Requirement 1** and tighten screws 4 and 5.
- Making sure that there is some play in the bevel gear, tighten screws 1.
- With retaining collar 7 touching bevel gear 8 tighten screws 2 and 3.
- Adjust needle guard 6 (screw 9) according to **requirement 3**.



When the hook is changed, make sure that the markings 10 and 11 are both on one side.

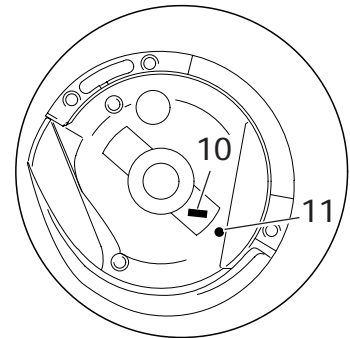

12.04.05 Needle rise, hook clearance, needle height and needle guard on the PFAFF 574

Requirement

With the needle bar positioned 2,0 mm after BDC on both hooks

1. the hook point must be at needle centre with a hook-to-needle clearance of 0.05 to 0.1 mm;
2. the top of the needle eye must be 0.8 to 1.0 mm below the hook points;
3. the needle guard 9 must touch the needle lightly.

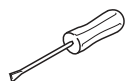
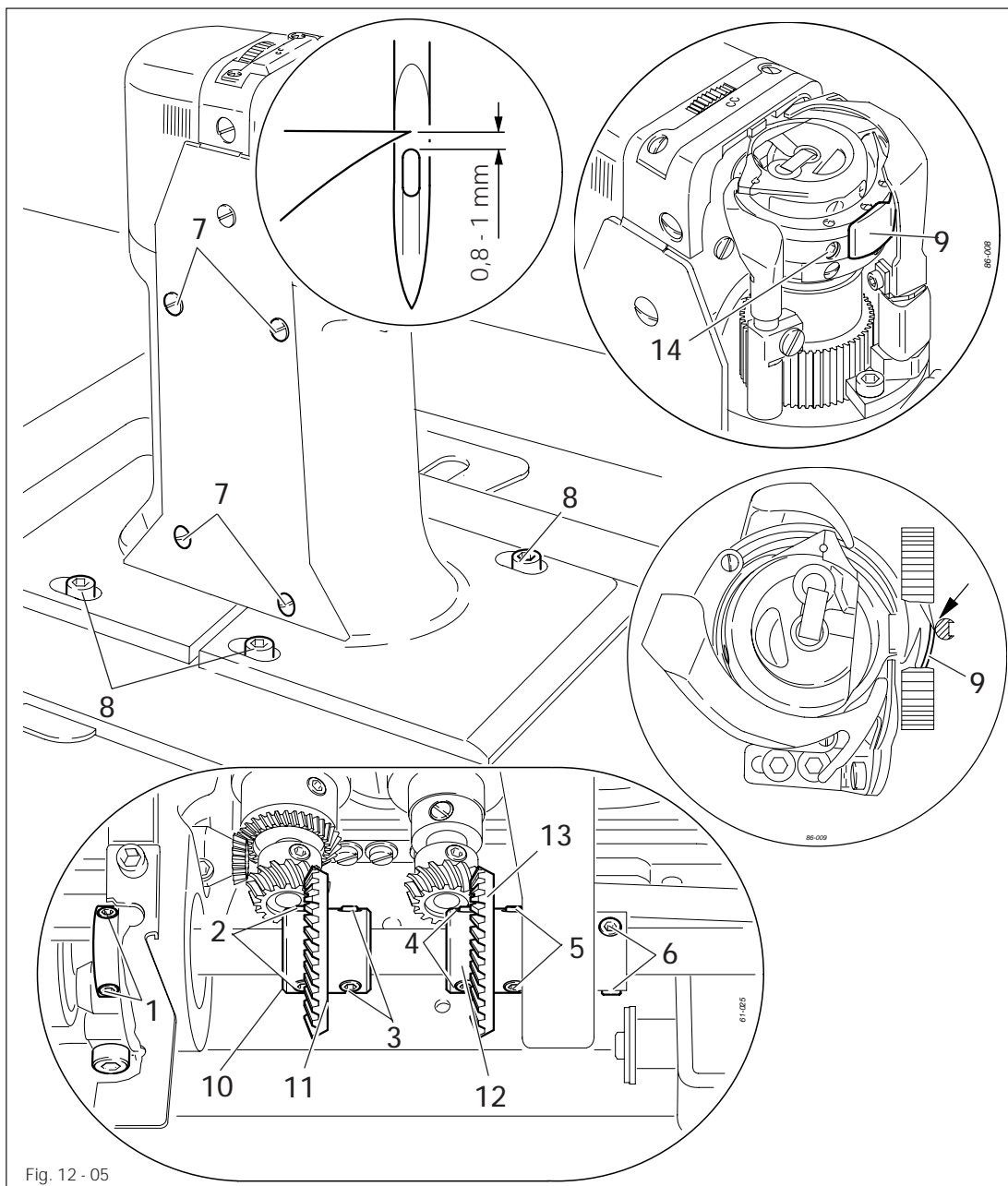

- Loosen screws 1, 2, 3, 4, 5, 6 and 7.
- Loosen screws 8 slightly.
- Bring needle bar to 2,0 mm past BDC:
- Set both hook points at needle centre, making sure that the needles are not deflected by needle guard 9.

- Adjust needle height according to **Requirement 2**.
- Adjust both hook posts according to **Requirement 1** and tighten screws **8**.
- Tighten screws **1** and **6**.
- Making sure that there is some play in the bevel gear, tighten screws **3** and **5**.
- With retaining collar **10** touching bevel gear **11** tighten screws **2**.
- With retaining collar **12** touching bevel gear **13** tighten screws **4**.
- Tighten screws **7** on both sides of the post.
- Adjust needle guard **9** (screw **14**) on both hooks according to **requirement 3**.



When a hook is changed, make sure that the markings **15** and **16** are both on one side.

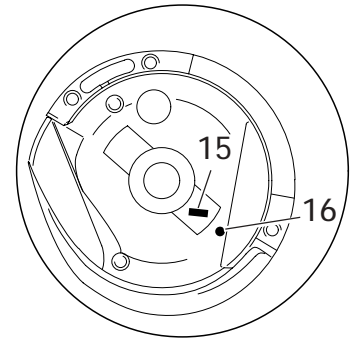

Adjustment

12.04.06 Needle rise, hook clearance, needle height and needle guard on the PFAFF 591

Requirement

With the needle bar positioned 2,0 mm after BDC and the stitch length set at "0.8"

1. the hook point must be at needle centre with a hook-to-needle clearance of 0.05 to 0.1 mm;
2. the top of the needle eye must be 0.8 to 1.0 mm below the hook point;
3. the needle guard 6 must touch the needle lightly.

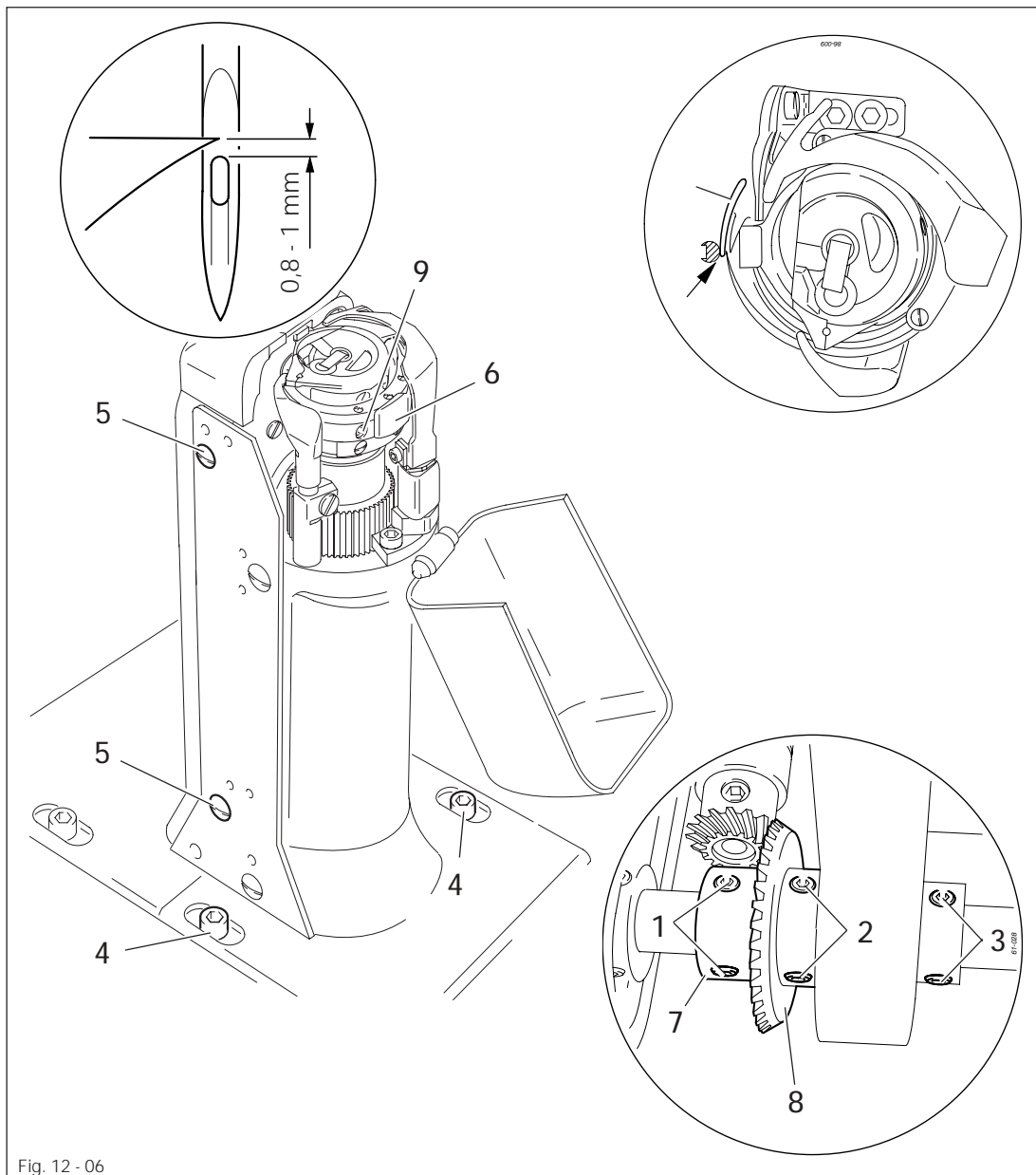
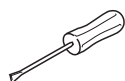

Fig. 12 - 06



- Set stitch length at "0.8".
- Loosen screws 1, 2, 3, 4 and 5.
- Bring needle bar to 2.0 mm past BDC:
- Set hook point at needle centre, making sure that the needle is not deflected by needle guard 6.
- Adjust needle height according to Requirement 2.

- Adjust hook post according to **Requirement 1** and tighten screws 4.
- Making sure that there is some play in the bevel gear, tighten screws 2.
- With retaining collar 7 touching bevel gear 8 tighten screws 1.
- Adjust needle guard 6 (screw 9) according to **requirement 3**.



When the hook is changed, make sure that the markings 10 and 11 are both on one side.

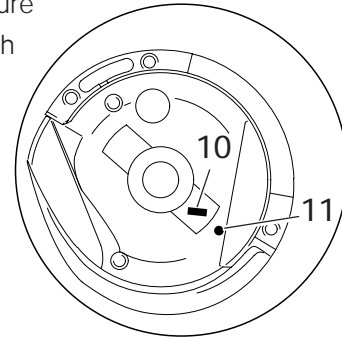

Adjustment

12.04.07 Needle position crosswise to sewing direction on the PFAFF 571

Requirement

When the stitch length is set at its maximum, the needle must be positioned in the centre of the needle hole when entering and coming out of the needle plate.

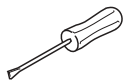
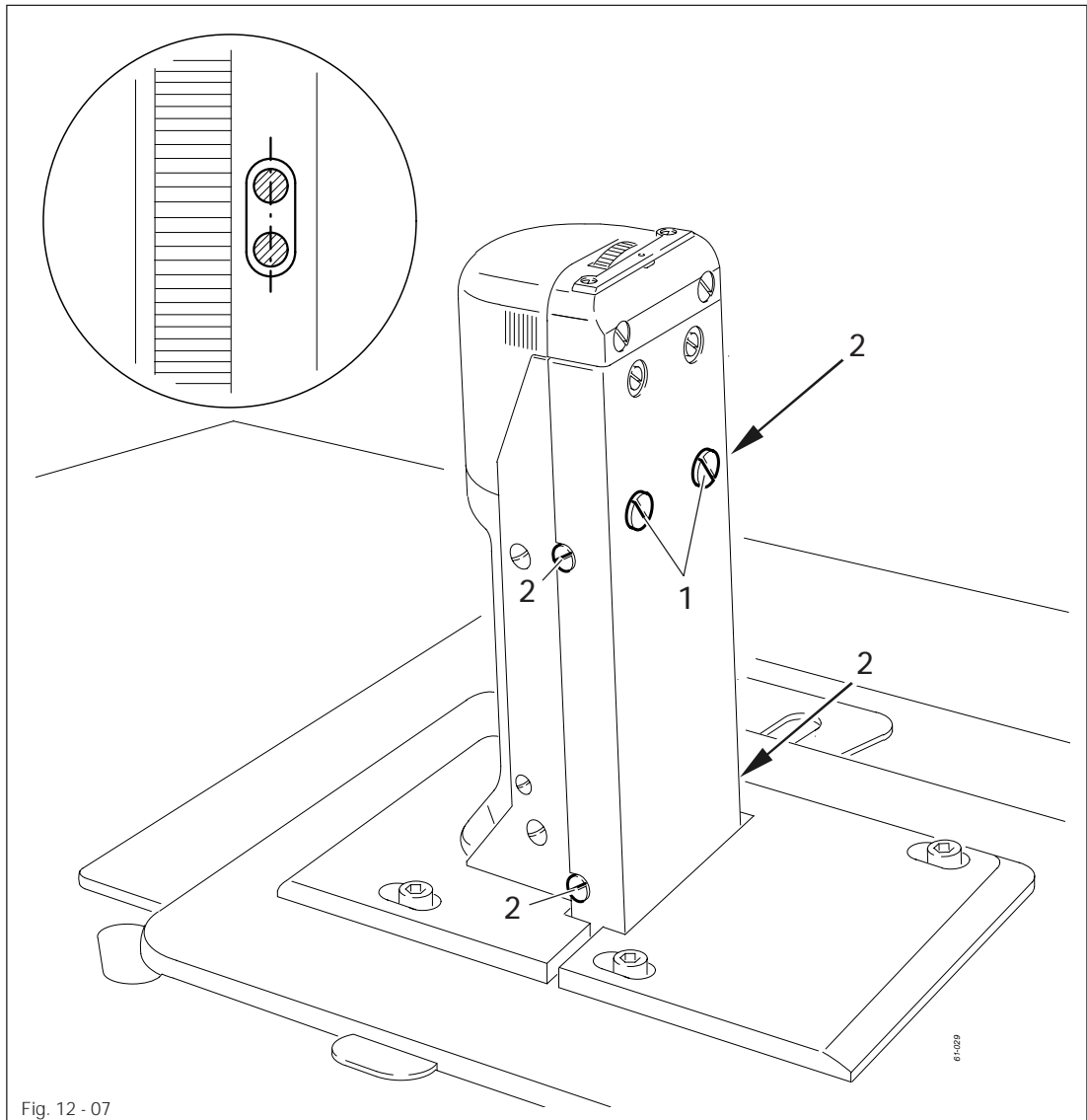

- Turn screws 1 (screws 2, on both sides of the post) according to the requirement.

12.04.08 Needle position crosswise to sewing direction on the PFAFF 574

Requirement

As seen crosswise to the sewing direction, the needles must penetrate in the centre of their needle holes.

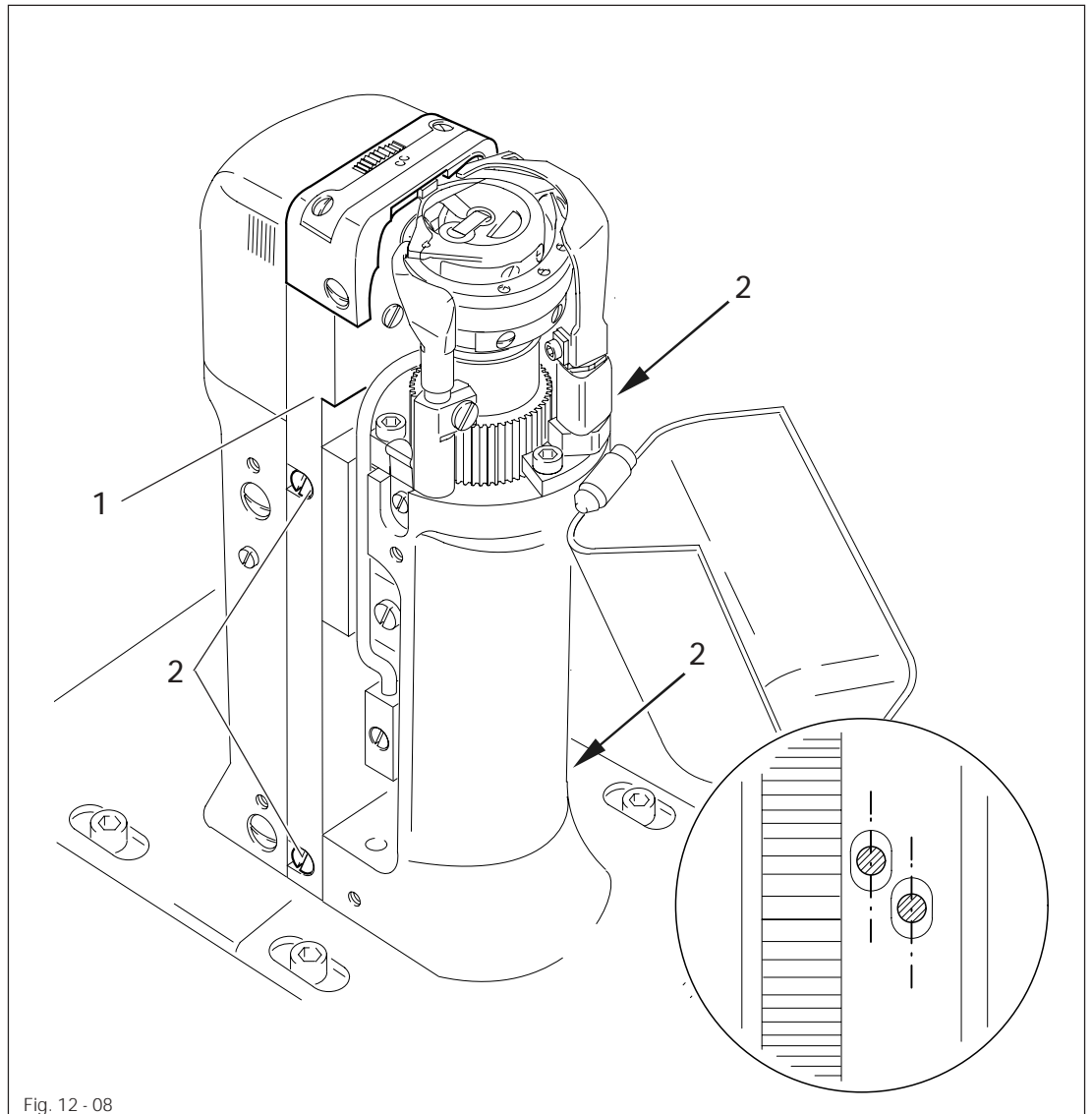

Fig. 12 - 08

- Shift bearing plate 1 (screws 2, on both sides of the post) according to the requirement.

Adjustment

12.04.09 Needle position crosswise to sewing direction on the PFAFF 591

Requirement

As seen crosswise to the sewing direction, the needle must penetrate in the centre of the needle hole.

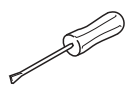
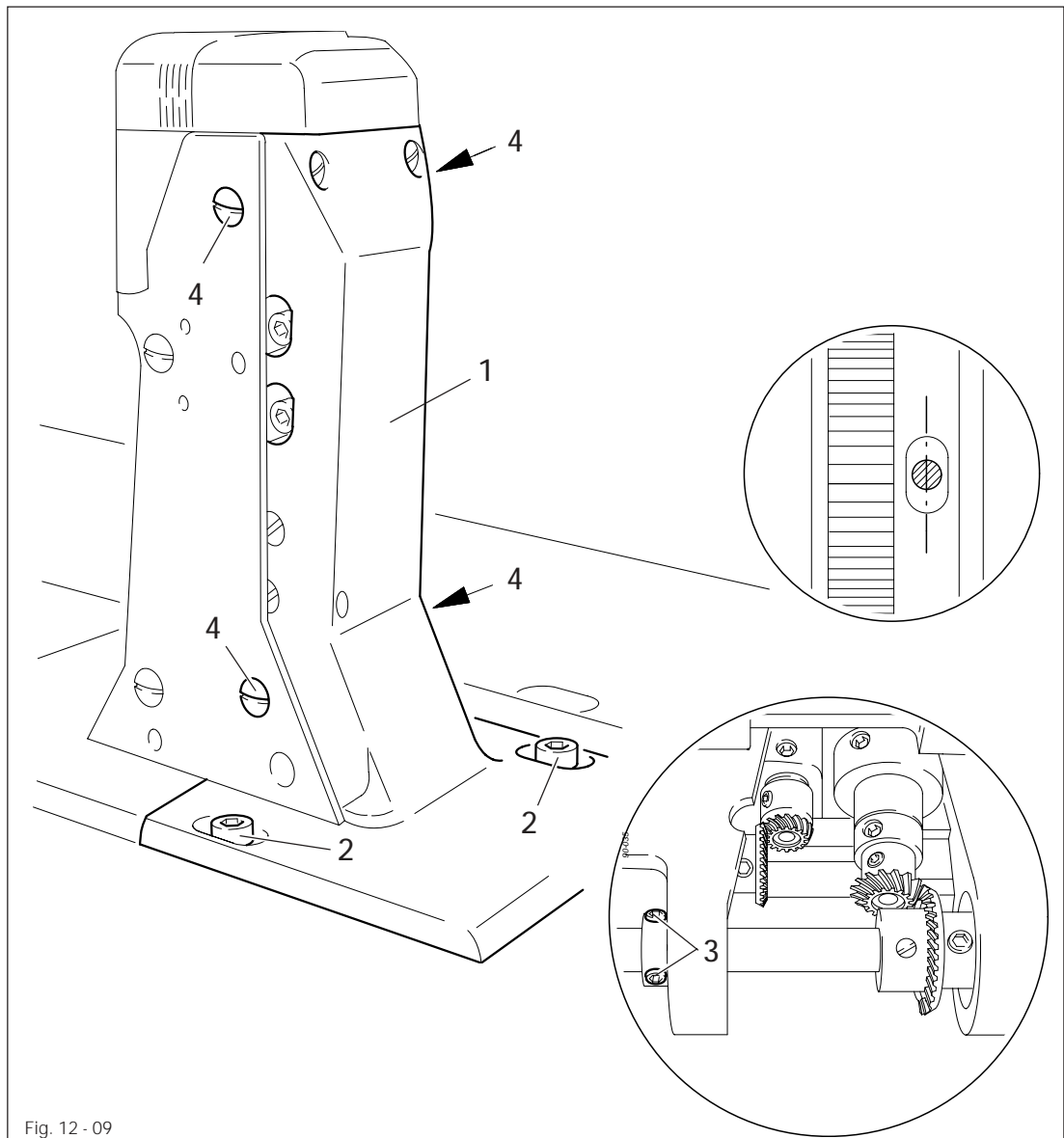

- Adjust feed wheel post 1 (screws 2, 3 and 4) according to the requirement.

12.04.10 Height and stroke of the bobbin case opener

Requirement

1. The top edges of the bobbin case opener 1 and bobbin case base 3 should be on one level.
2. When the bobbin case opener 1 has deflected the bobbin case to its furthest point, the catch of the bobbin case should be 0.3 – 0.5 mm from the back edge of the needle plate recess.

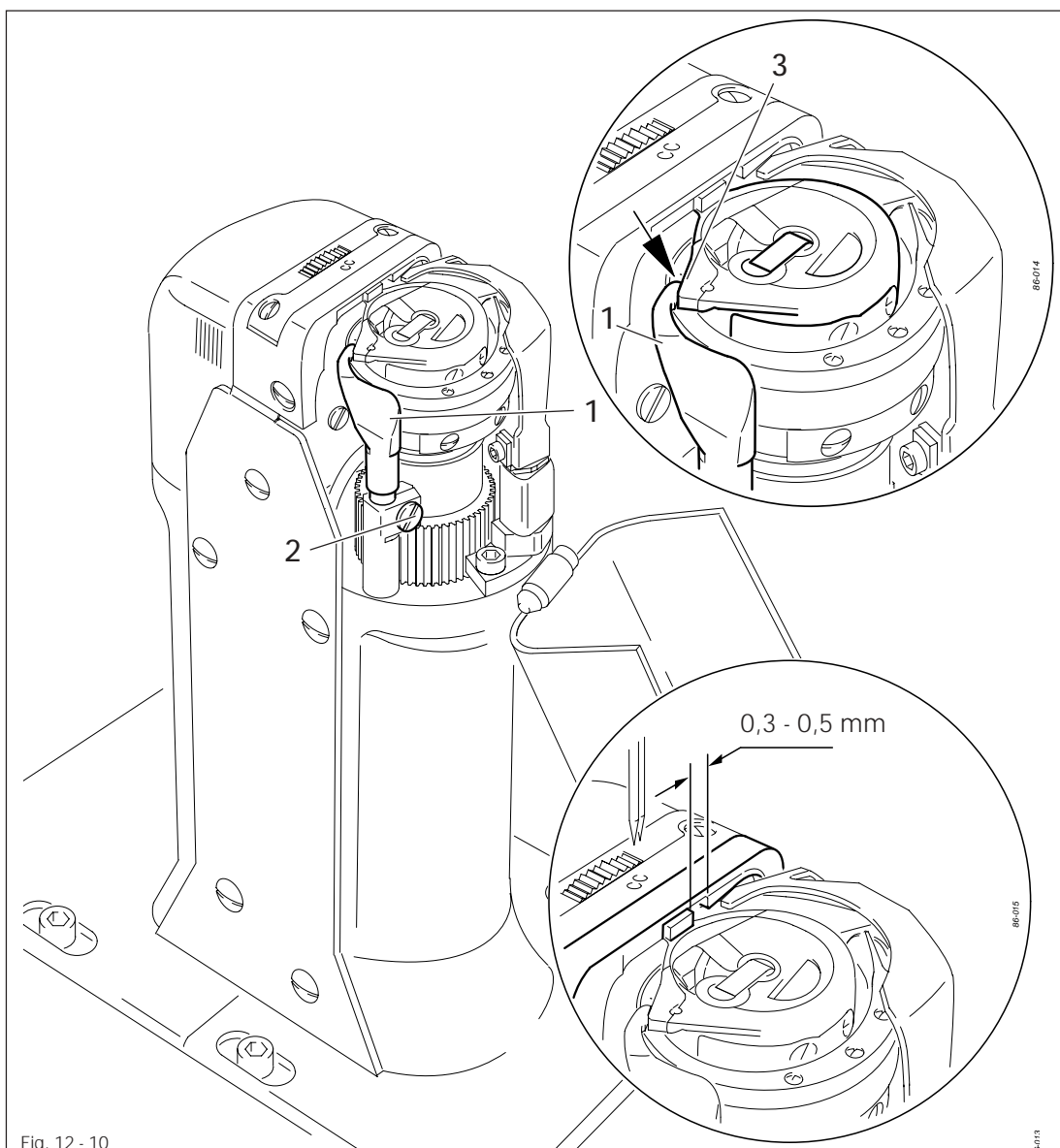
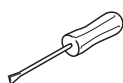

Fig. 12 - 10



- Adjust bobbin case opener 1 (screw 2) in accordance with **requirement 1**.
- Turn the balance wheel until the bobbin case opener has deflected the bobbin case to its furthest point.
- Adjust bobbin case opener 1 (screw 2) in accordance with **requirement 2**.



On the PFAFF 574 these adjustments must be repeated on the right post. Depending on the thread size, a variation of the setting in **Requirement 2** is permitted.

12.04.11 Height of the feed wheel on the PFAFF 571

Requirement

1. When pressure is applied to the feed wheel 4, it should protrude from the needle plate by tooth height (approx. 0.8 mm)
2. When no pressure is applied to the feed wheel 4, it should have a vertical play of approx. 0.3 mm.

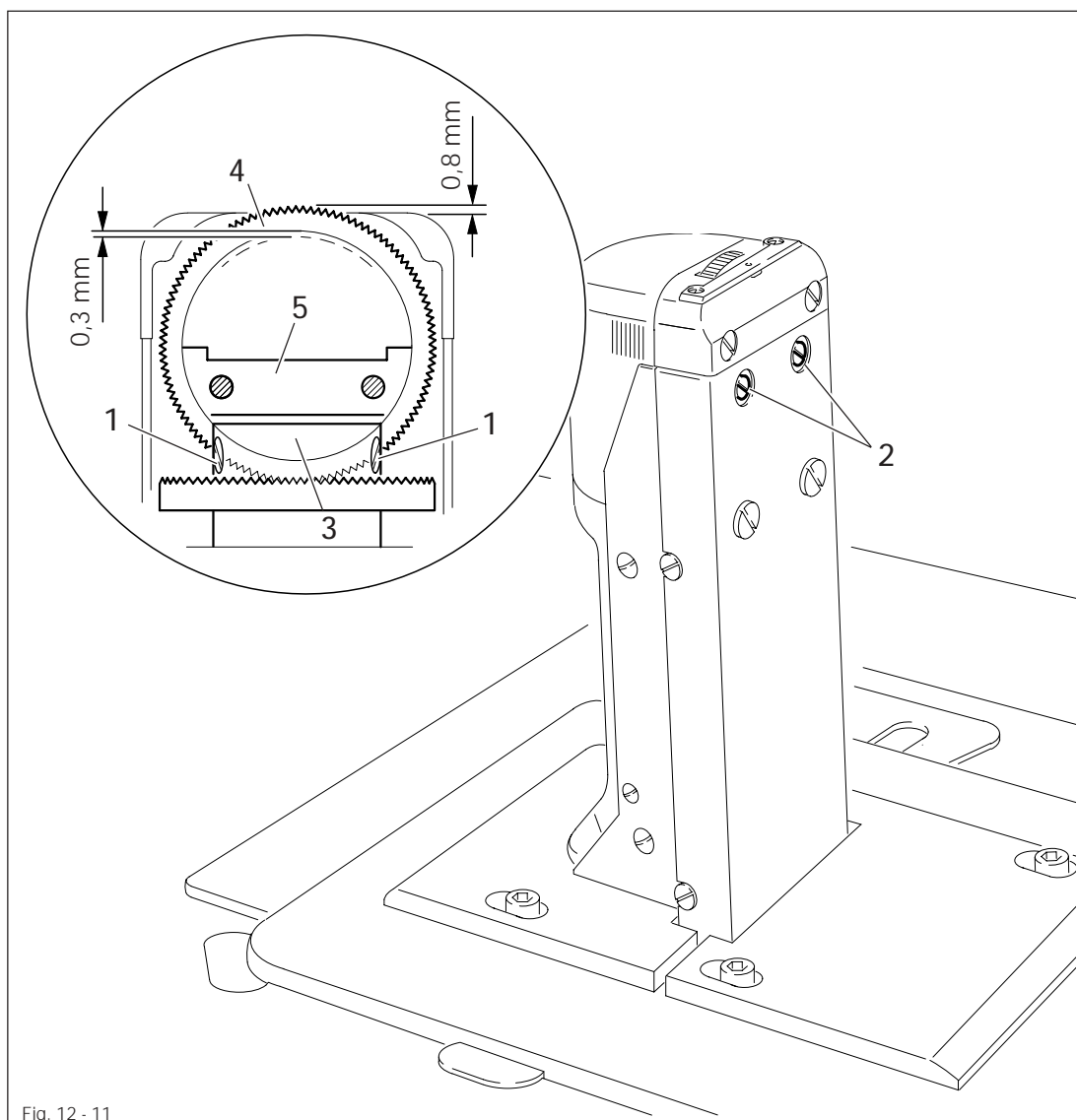
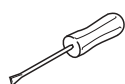

Fig. 12 - 11



- Swing out the roller presser.
- Loosen screws 1 and 2.
- Adjust drive wheel 3 according to **requirement 1**, taking care to see that the teeth of drive wheel 3 and feed wheel 4 lock into each other properly.
- Tighten screws 1.
- Adjust guide 5 according to **requirement 2** and tighten screws 2.s

12.04.12 Height of the feed wheel on the PFAFF 574

Requirement

1. When pressure is applied to the feed wheel 4, it should protrude from the needle plate by tooth height (approx. 0.8 mm)
2. When no pressure is applied to the feed wheel 4, it should have a vertical play of approx. 0.3 mm.

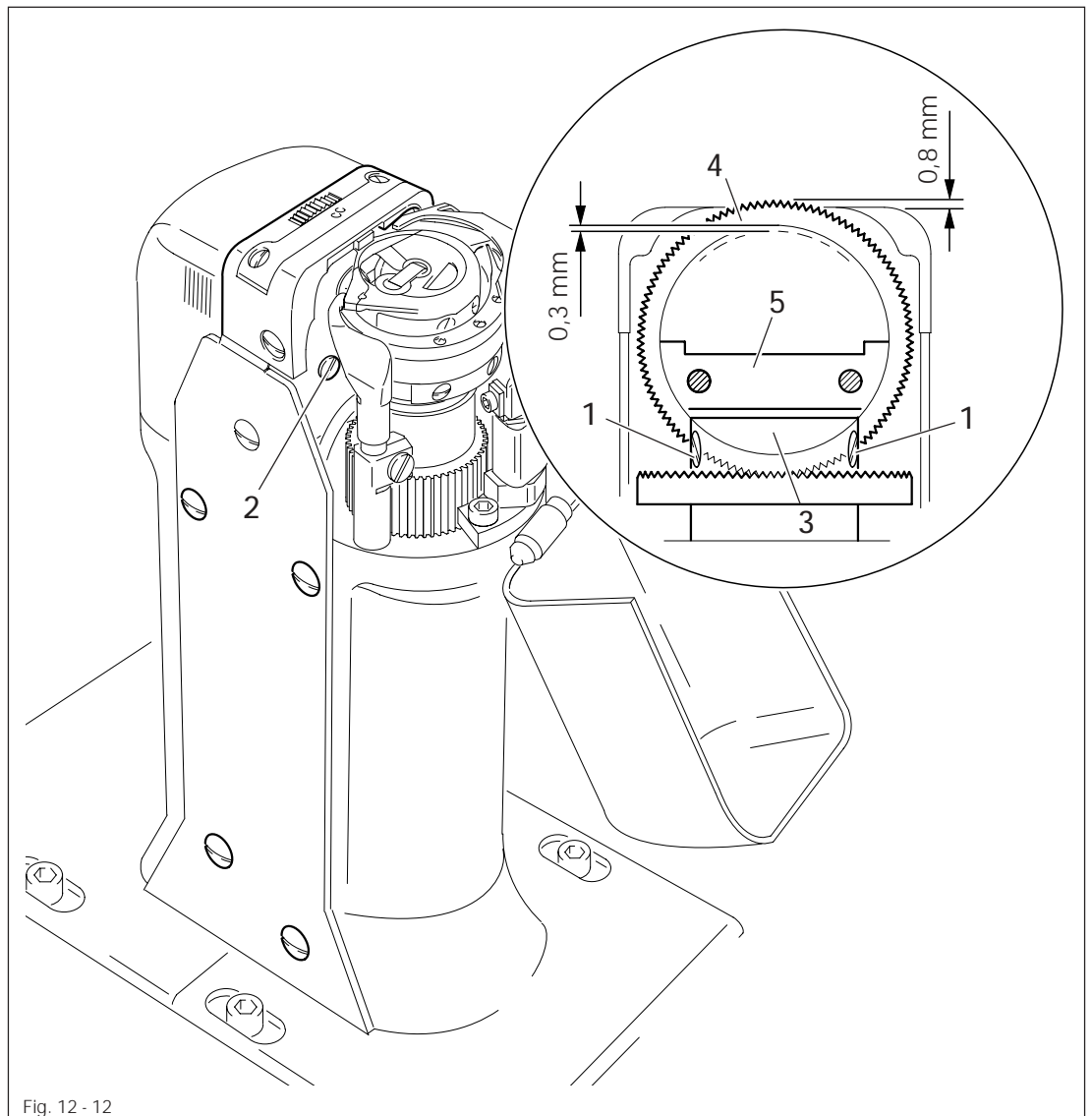
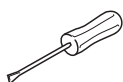

Fig. 12 - 12



- Swing out the roller presser.
- Loosen screws 1 and 2 (two screws each).
- Adjust drive wheel 3 according to requirement 1, taking care to see that the teeth of drive wheel 3 and feed wheel 4 lock into each other properly.
- Tighten screws 1.
- Adjust guide 5 according to requirement 2 and tighten screws 2.

12.04.13 Height of the feed wheel on the PFAFF 591

Requirement

The feed wheel should protrude from the needle plate by tooth height (approx. 0.8 mm)

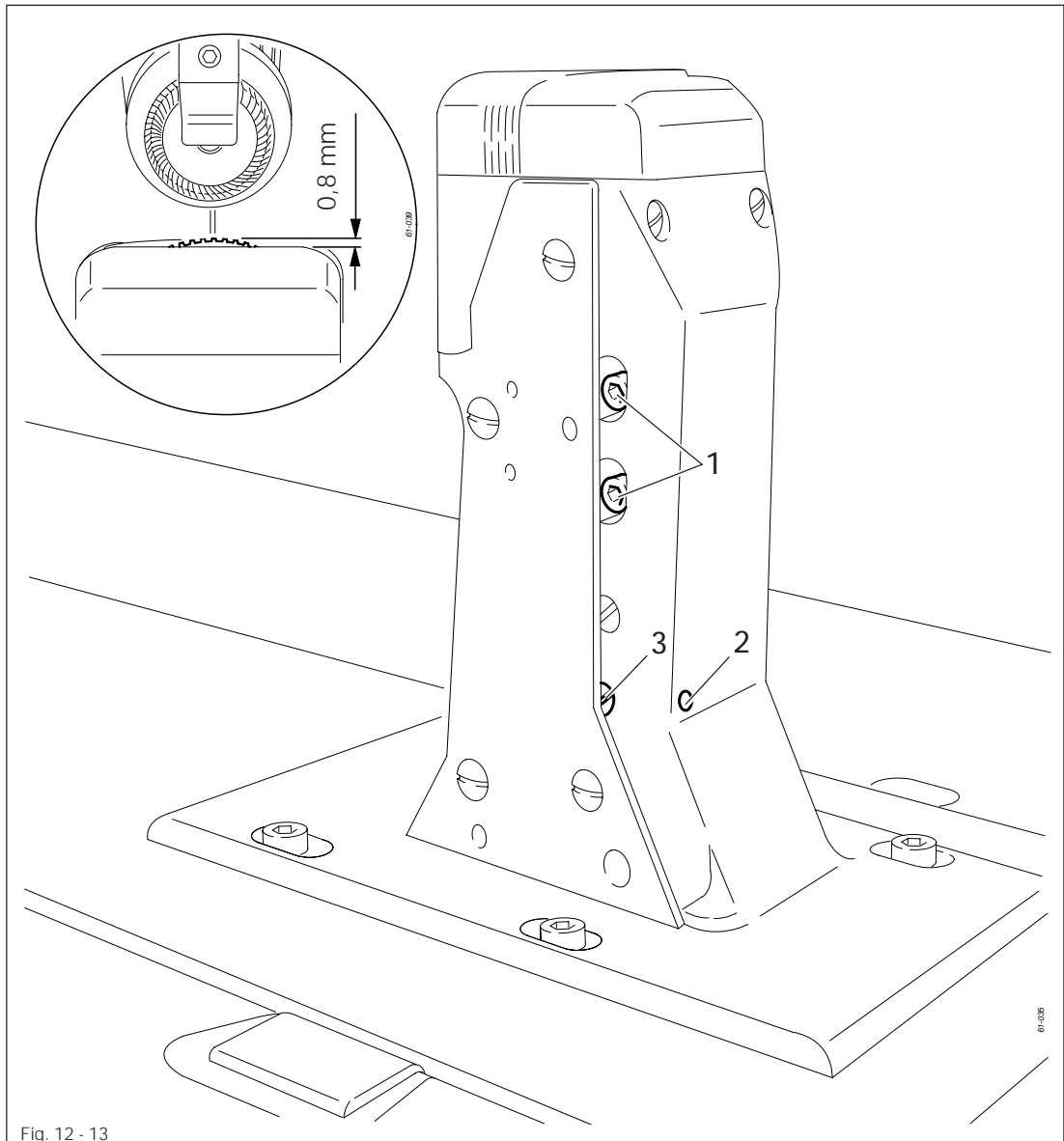
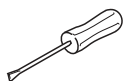

Fig. 12 - 13



- Swing out the roller presser.
- Loosen screws 1.
- Adjust eccentric 3 (fastening screw accessible through hole 2) according to the requirement.
- Tighten screws 1.

12.04.14 Stitch length control eccentric

Requirement

When the needle (with maximum stitch length set), coming from TDC, is 3 mm above the needle plate, the crank 3 must have reached its front point of reversal.

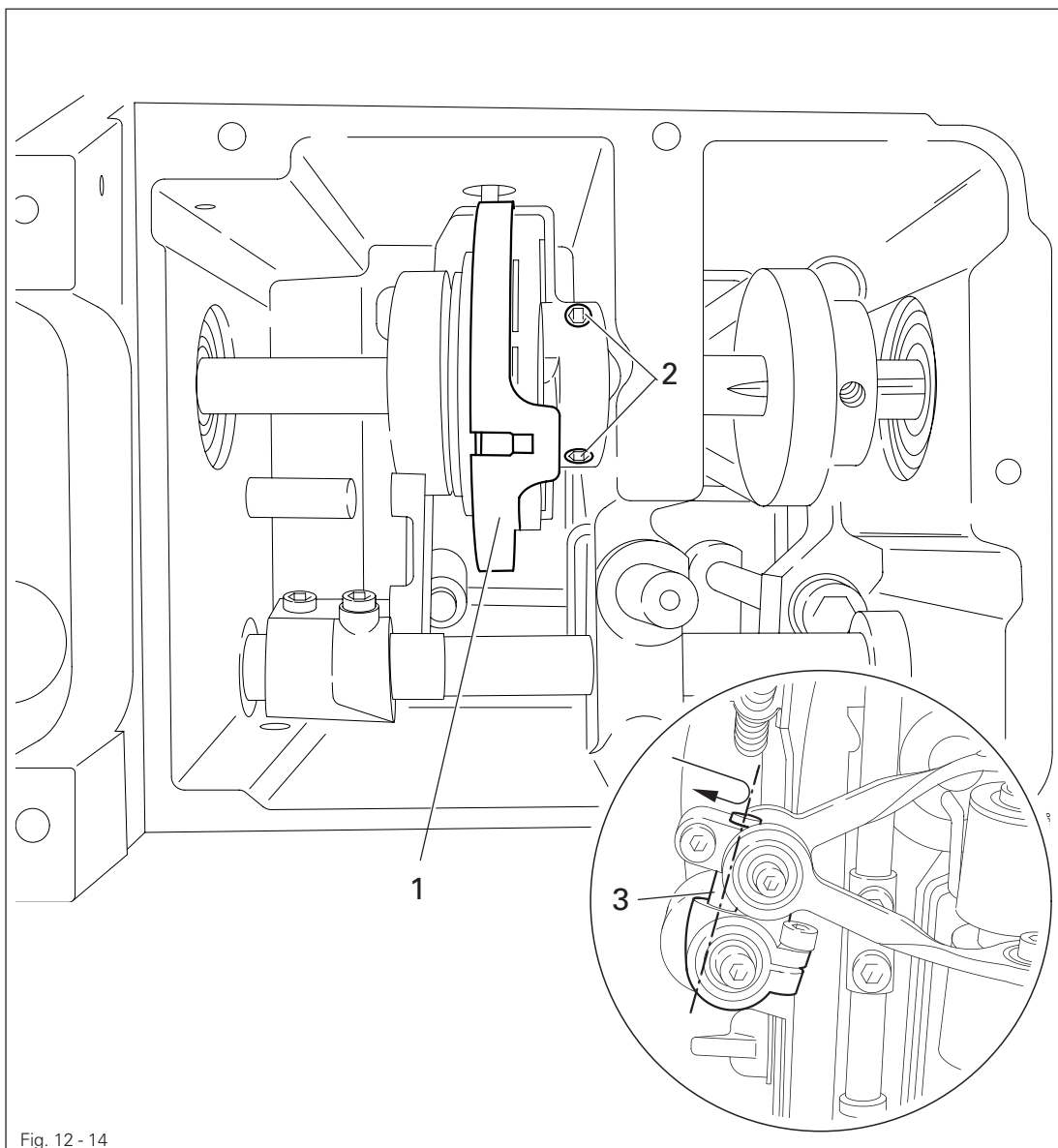
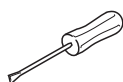

Fig. 12 - 14



- Set the maximum stitch length.
- Turn stitch length control device 1 (screws 2) according to the requirement.

12.04.15 Stitch length scale disk

Requirement

When the stitch length control device is locked in position, and the maximum stitch length is set, the marking line of the highest number on the scale disk 1 must be opposite the lower edge 3 of the belt guard recess.

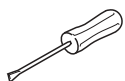
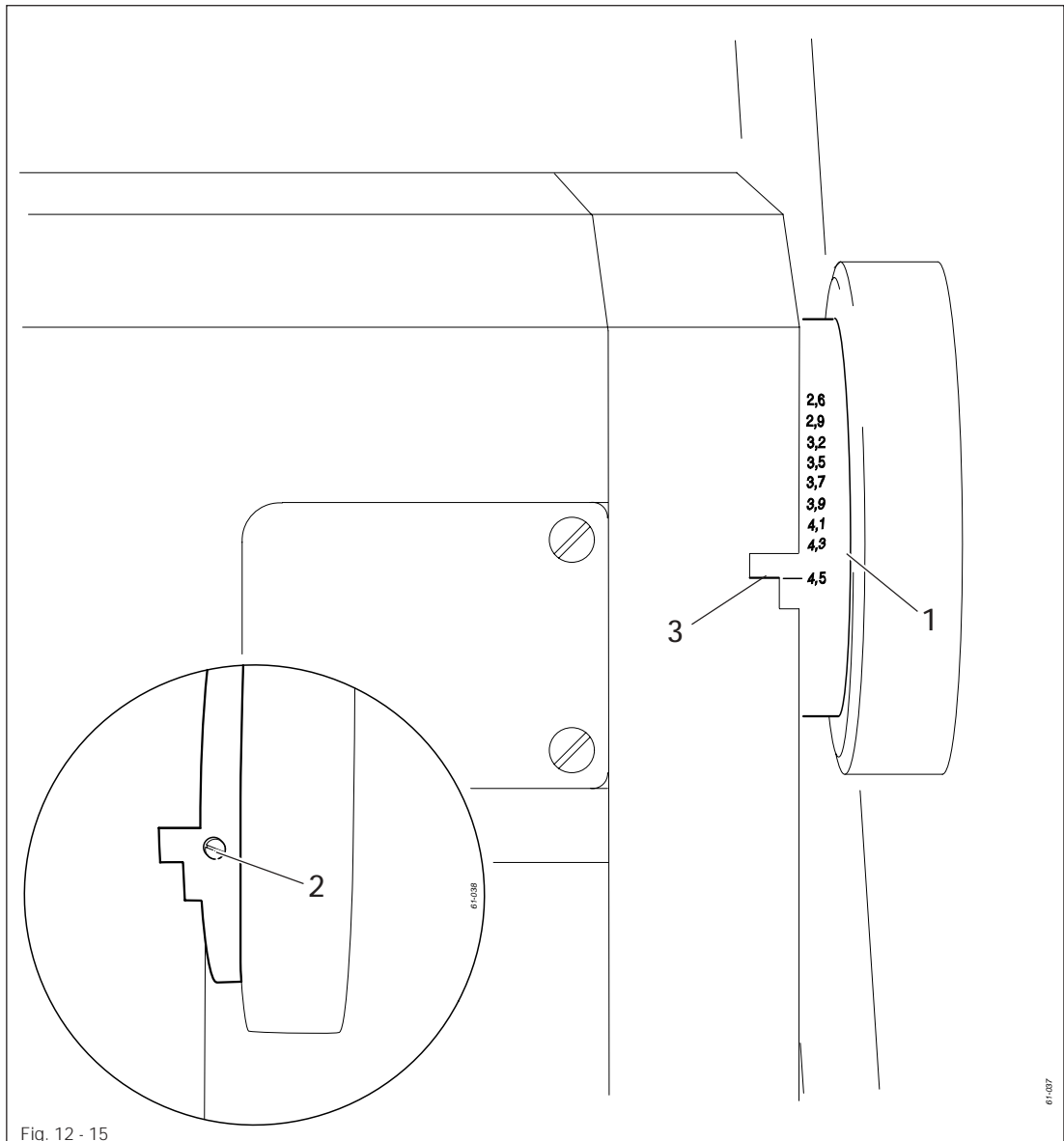

- Set the maximum stitch length.
- Turn the scale disk 1 (screws 2) according to the requirement.

12.04.16 Shaft crank to feed wheel drive

Requirement

When the maximum stitch length is set, the linkage rod 3, or linkage rods 3 and 4 on the models 571 and 591, must be able to move freely when the balance wheel is turned.

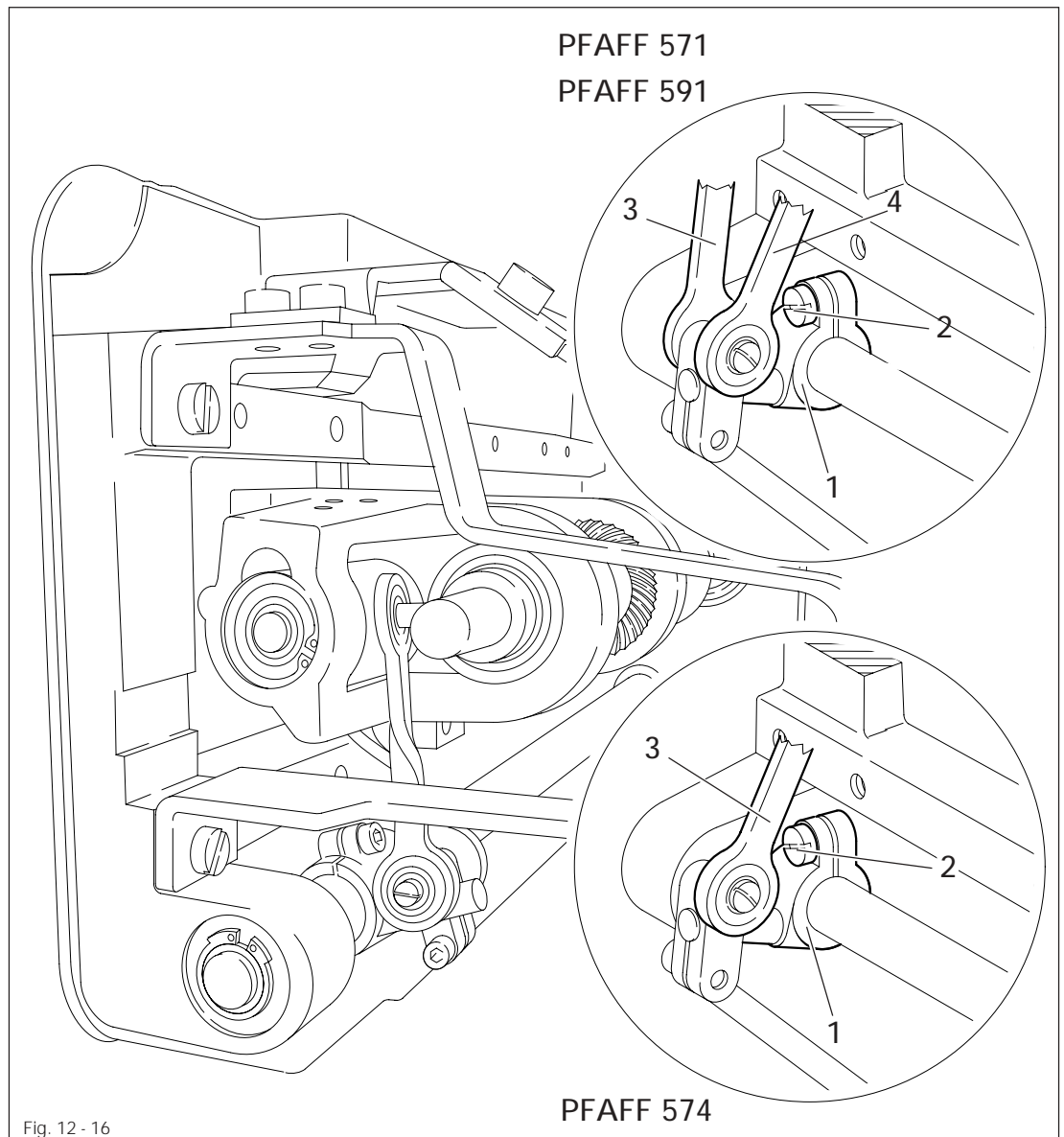
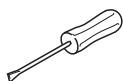

Fig. 12 - 16



- Set the maximum stitch length.
- Twist or shift the shaft crank 1 (screw 2) according to the requirement.

Adjustment

12.04.17 Shaft crank to roller presser drive

Requirement

When the maximum stitch length is set, the linkage rods 3 and 4 must be able to move freely at their left and right point of reversal when the balance wheel is turned.

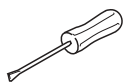
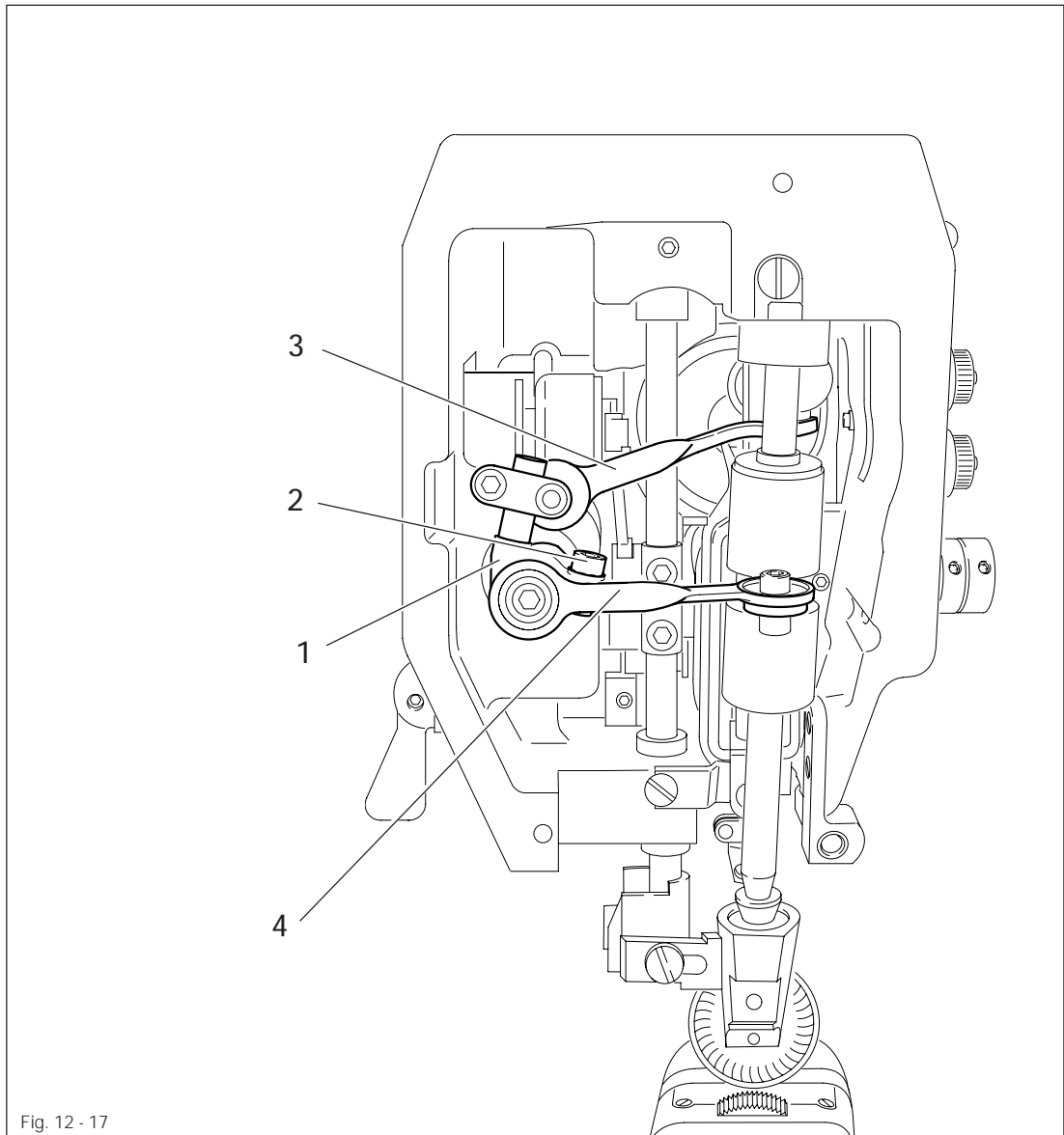

- Set the maximum stitch length.
- Twist clamp crank 1 (screw 2) according to the requirement.

12.04.18 Clearance between roller presser and feed wheel

Requirement

When the presser bar lifter is raised, the clearance between the roller presser and the feed wheel must be 7 mm.

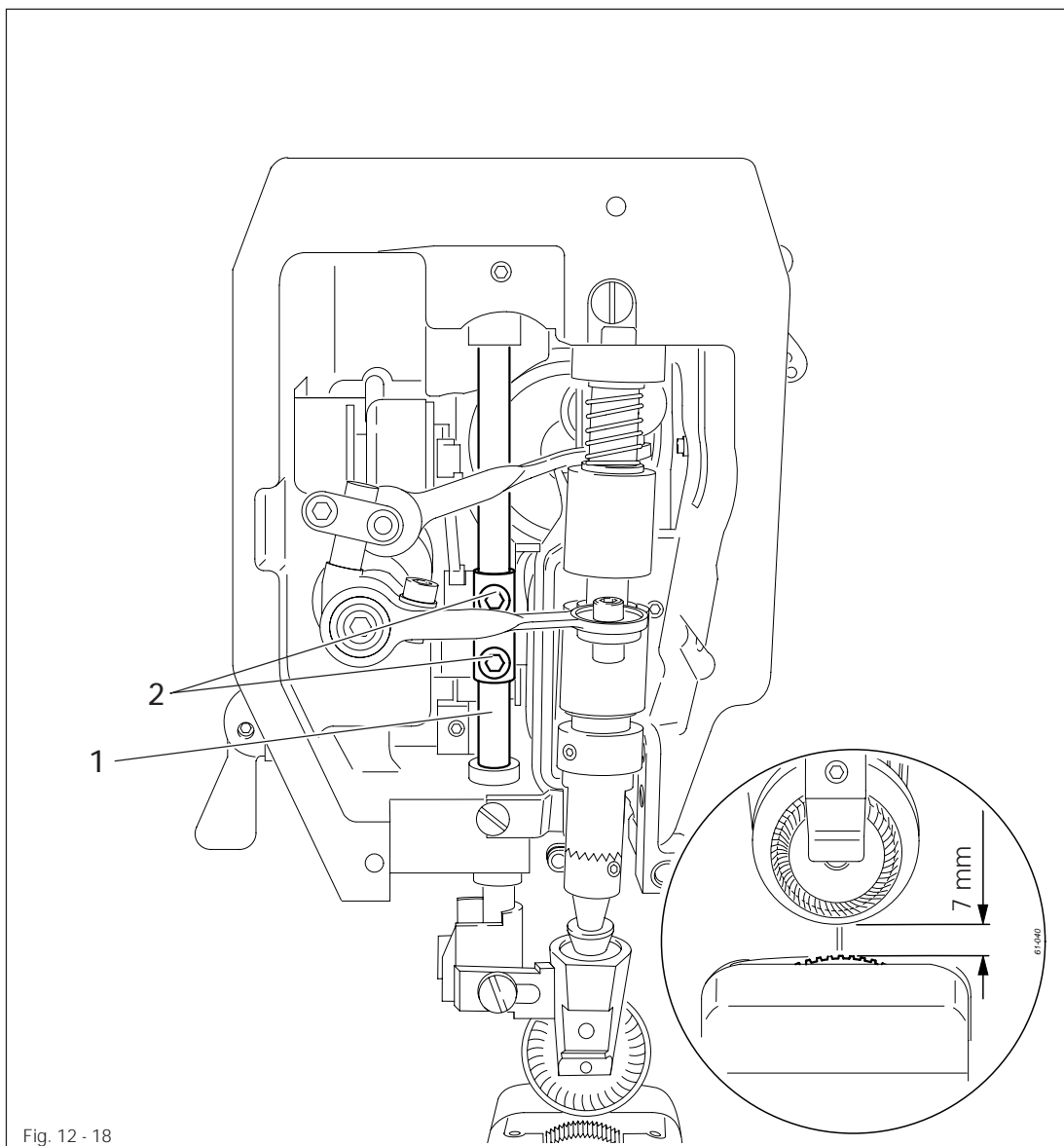
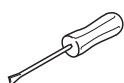

Fig. 12 - 18



- Raise the presser bar lifter.
- Adjust the presser bar 1 (screws 2) according to the **requirement**. Make sure that the roller presser is parallel to the feed wheel.

Requirements

When the roller presser 1 is touching the feed wheel 5 it must

1. be parallel to feed wheel 5, as seen in the direction of sewing,
2. be in the centre of the needle (on model 574 the left needle), as seen in the direction of sewing,
3. be as near as possible to the needle (on model 574 the left needle), as seen crosswise to the direction of sewing.

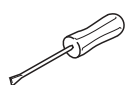
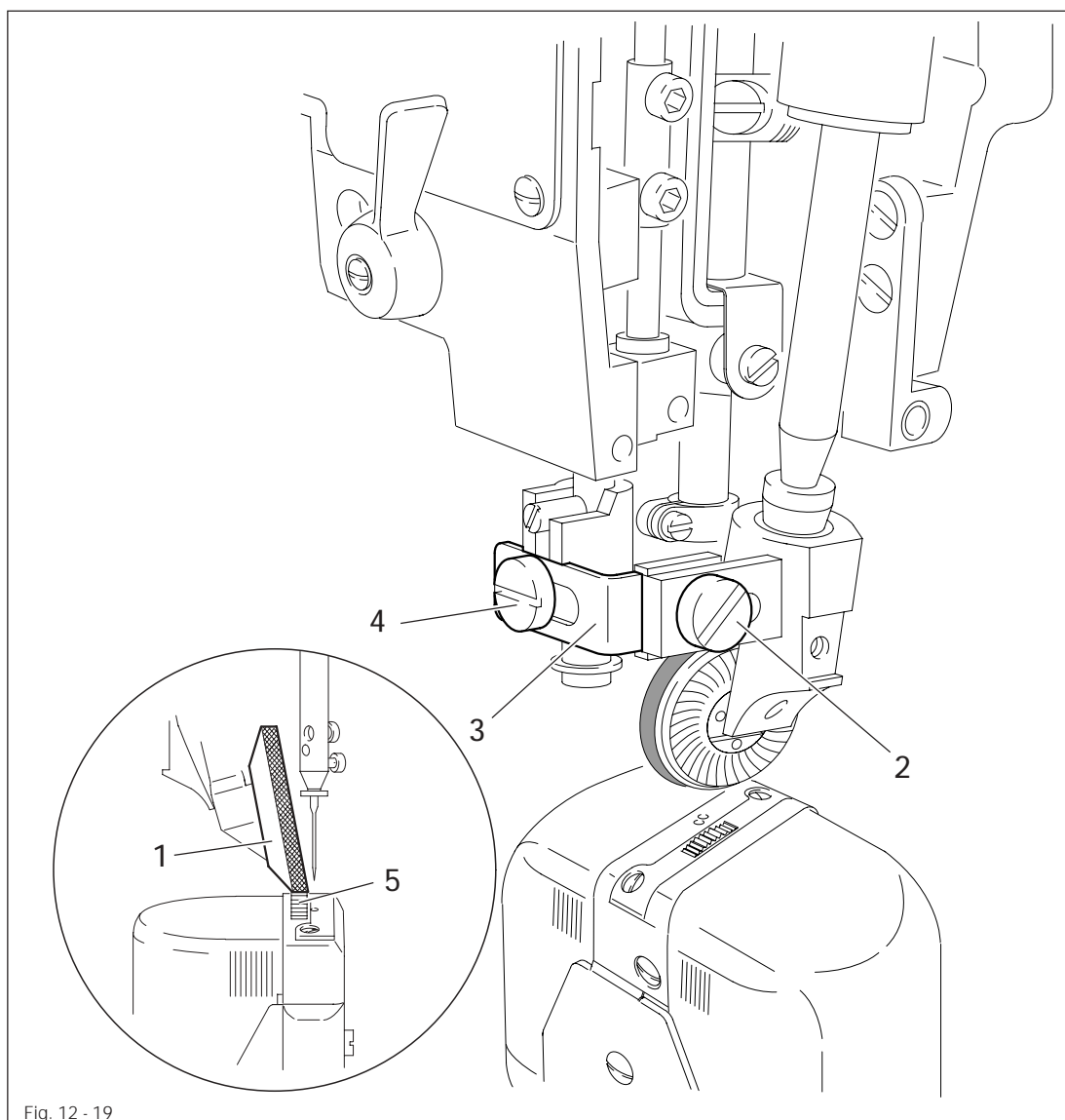

- Raise the roller presser.
- Always observe **requirement 1** for subsequent adjustments.
- Adjust roller presser (screw 2) according to **requirement 2**.
- Lower roller presser 1 to rest on feed wheel 5.
- Adjust roller presser bracket 3 (screw 4) according to **requirement 3**.



When sewing very tight curves, the roller presser 1 must be moved a little towards the operator.

12.04.20 Stitch length on stitch length scale

Requirement

When the stitch length is set at "3", and after the needle has entered a strip of leather 11 times, the total length from the first to last needle penetration must be 30 mm.

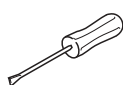
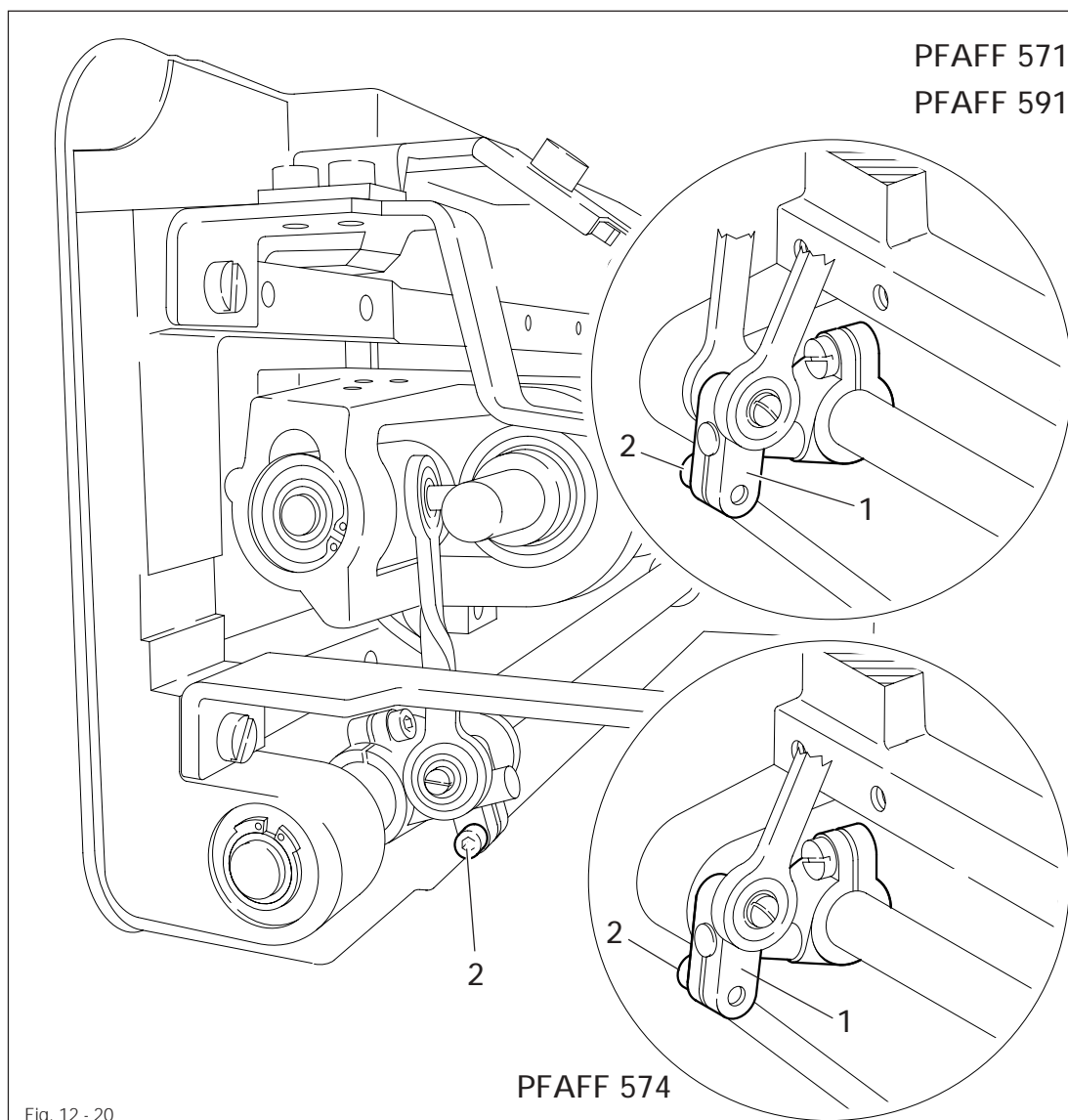

- Set stitch length "3".
- By turning the balance wheel, let the needle enter 11 times and measure the total length.
- Adjust clamp 1 (screw 2) according to the requirement.



Clamp 1 must not be positioned diagonally to the rock shaft!

Adjustment

12.04.21 Synchronization of roller presser and feed wheel

Requirement

After 30 needle penetrations in a strip of leather the total length from the first to the last penetration should be the same, both in the lower and the upper leather layer.

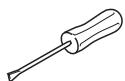
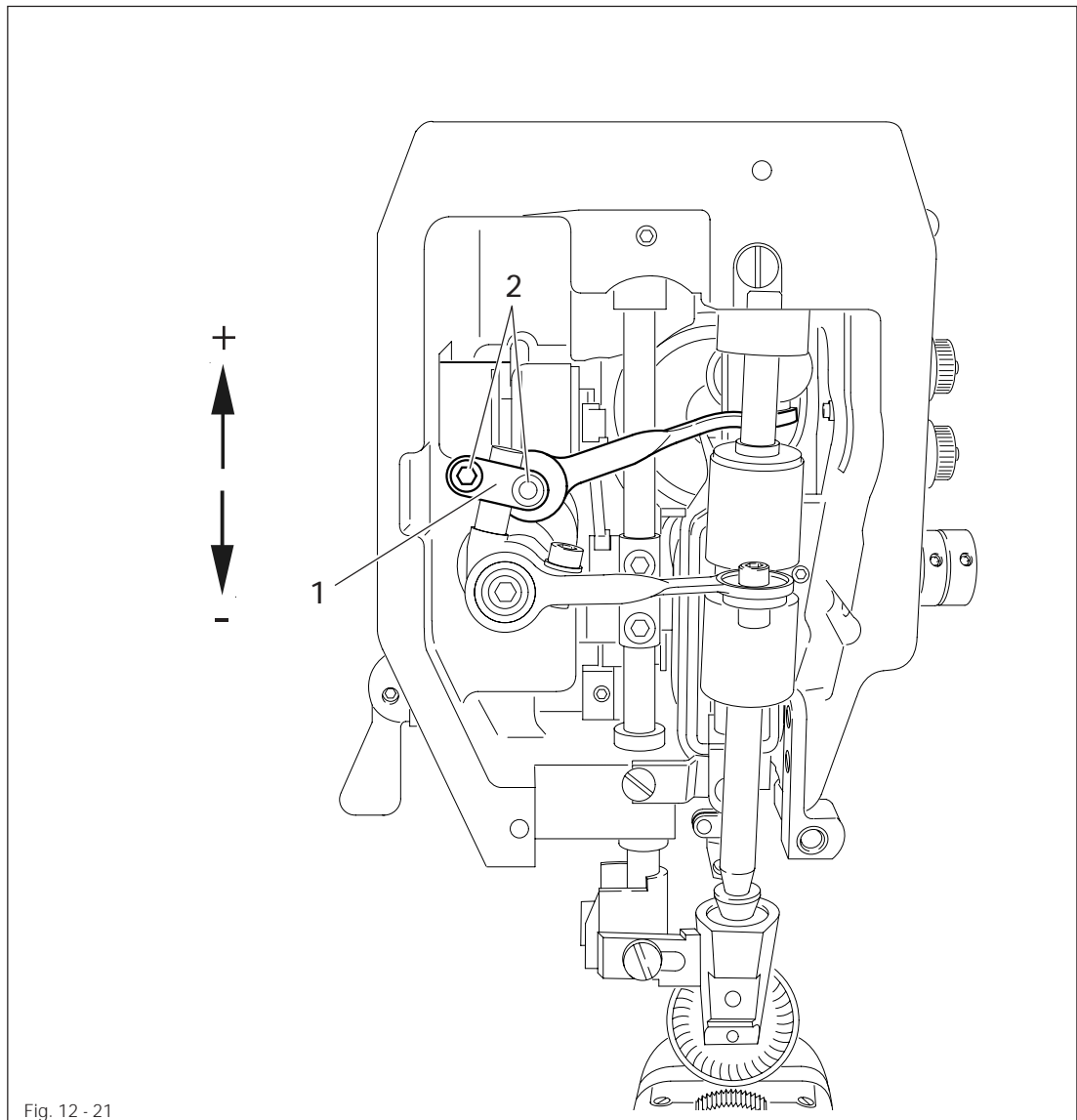

- Set stitch length "3".
- By turning the balance wheel, let the needle enter 30 times.
- Compare the total sewn length of the lower and upper leather layer.
- Adjust clamp 1 (screw 2) according to the requirement.



Clamp 1 must not be positioned diagonally to the rock shaft.

12.04.22 Retainer (only on model 574)

Requirements

The retainer 1 must

1. be as close as possible to the needle, as seen in the direction of sewing and
2. be in the centre of the needle, as seen crosswise to the direction of sewing.
3. When the roller presser is lowered, the distance between the retainer 1 and the workpiece must be 0.2 - 0.3 mm.

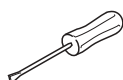
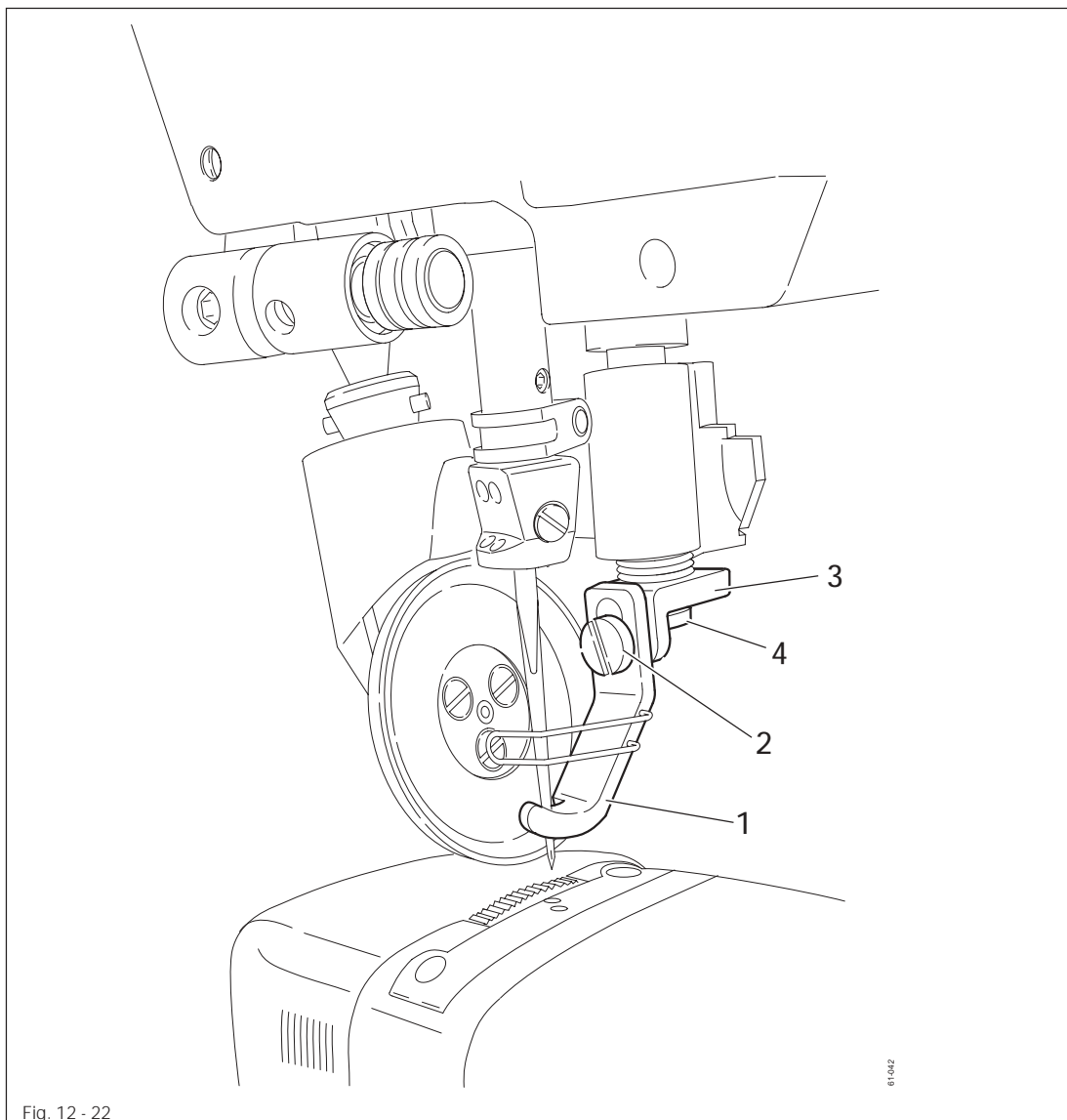

- Adjust retainer 1 (screw 2) according to requirement 3.
- Adjust bracket 3 (screw 4) according to requirement 1 and 2.

12.04.23 Knee lever

Requirements

1. Before the roller presser rises, the knee lever must still have a slight play.
2. When the knee lever is raised as far as possible, the lever for the roller presser must drop automatically.
3. Knee lever bar 5 must be at an angle of **approx. 75°** to the bedplate.

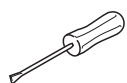
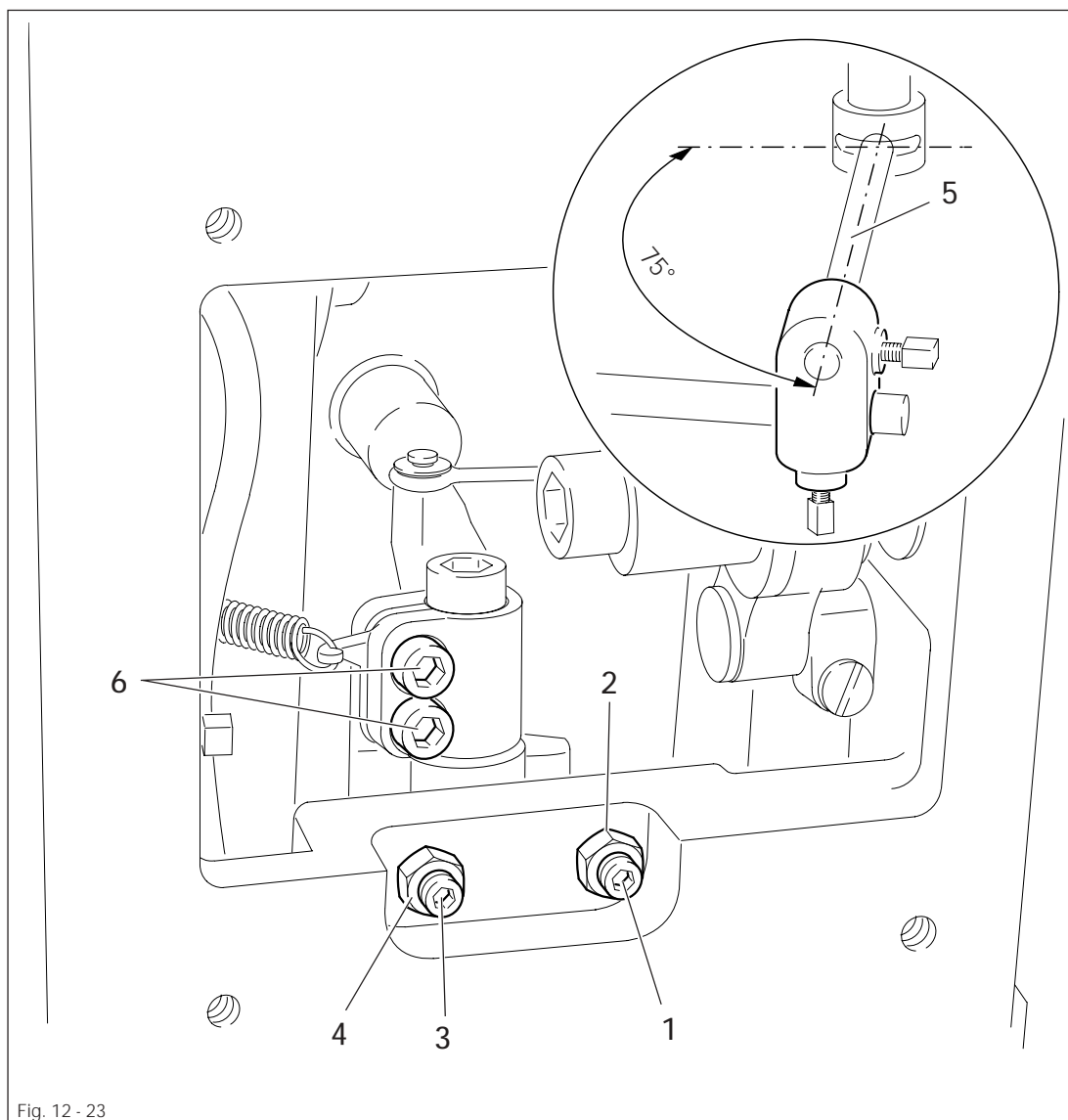

- Adjust screw 1 (nut 2) according to requirement 3.
- Adjust screw 3 (nut 4) according to requirement 2.
- Set bar 5 (Screws 6) according to requirement 3.

12.04.24 Needle thread tension release

Requirements

1. When the presser bar lifter is raised, the tension discs 3 should be pressed at least 0.5 mm apart.
2. When the roller presser is lowered, the tension must be fully effective.

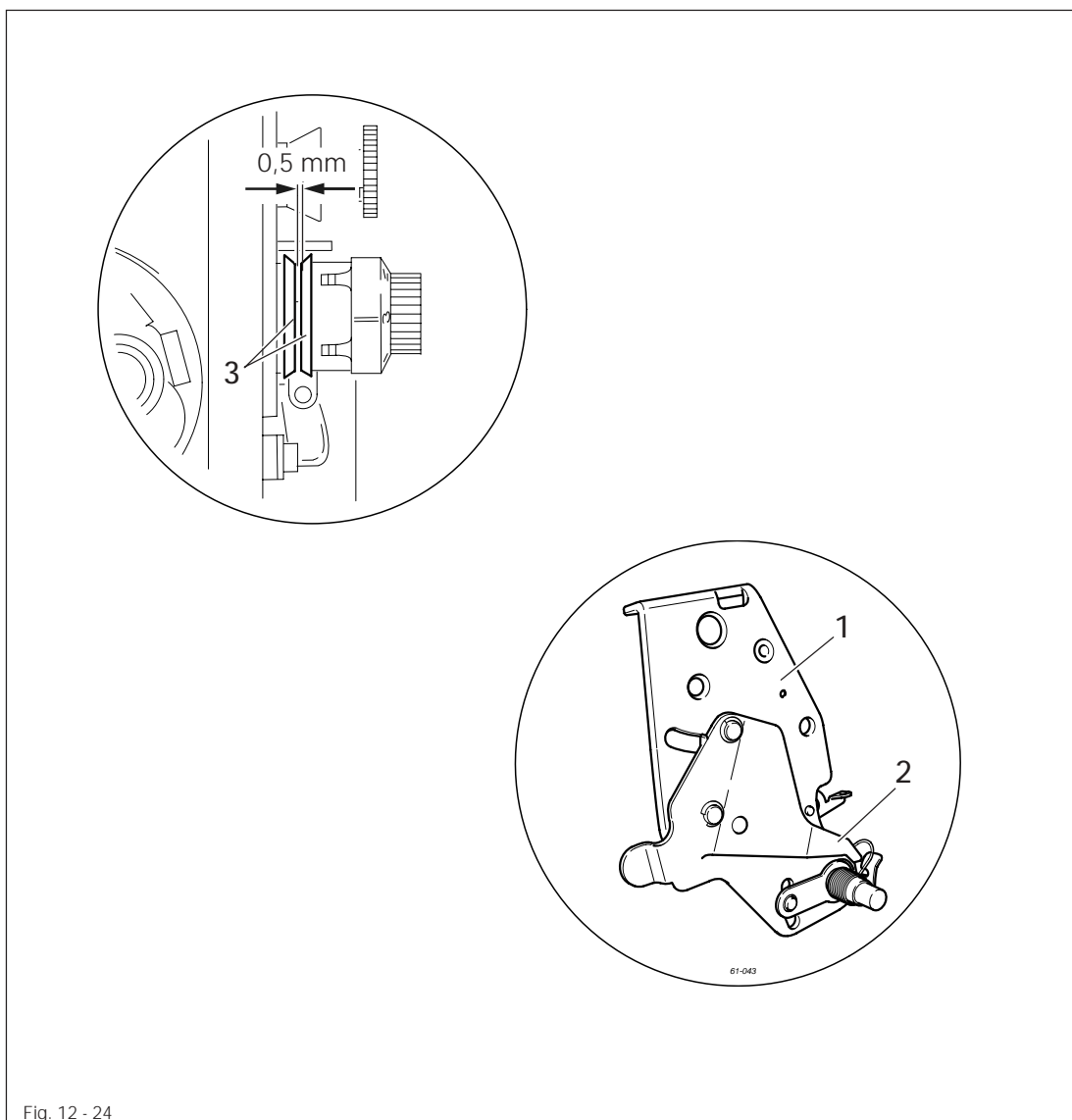
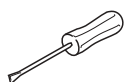

Fig. 12 - 24



- Align tension mounting plate 1 and pressure plate 2 according to the requirement.

12.04.25 Thread check spring (PFAFF 571 and 591)

Requirement

1. The movement of thread check spring 7 should be completed when the needle point penetrates the fabric (spring stroke approx. 7 mm).
2. When the largest thread loop is formed while the thread is passed around the hook, the thread check spring 7 should rise slightly from its support

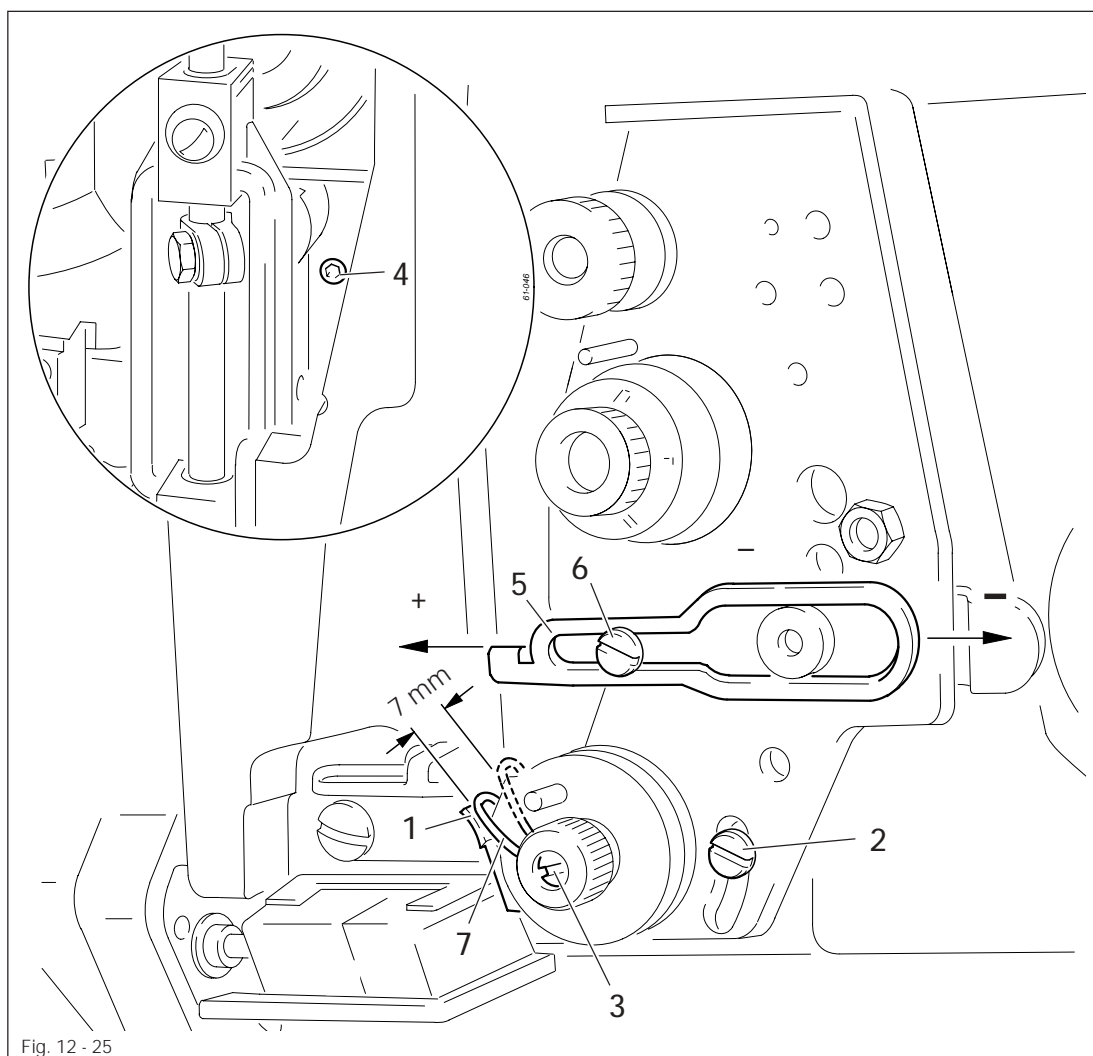
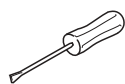

Fig. 12 - 25



- Adjust support 1 (screw 2) according to **requirement 1**.
- To adjust the spring tension turn screw 3 (screw 4).
- Adjust the thread regulator 5 (screw 6) according to **requirement 2**.



For technical reasons it may be necessary to deviate from the specified spring stroke or spring tension.

Move the thread regulator 5 (screw 6) towards "+" (= more thread) or "-" (= less thread).

12.04.26 Thread check springs (PFAFF 574)

Requirement

1. The movement of thread check springs **3** and **6** should be completed when the needle points penetrate the fabric (spring stroke approx. **7 mm**).
2. When the largest thread loop is formed while the thread is passed around the hook, the thread check springs **3** and **6** should rise slightly from supports **1** and **9**.

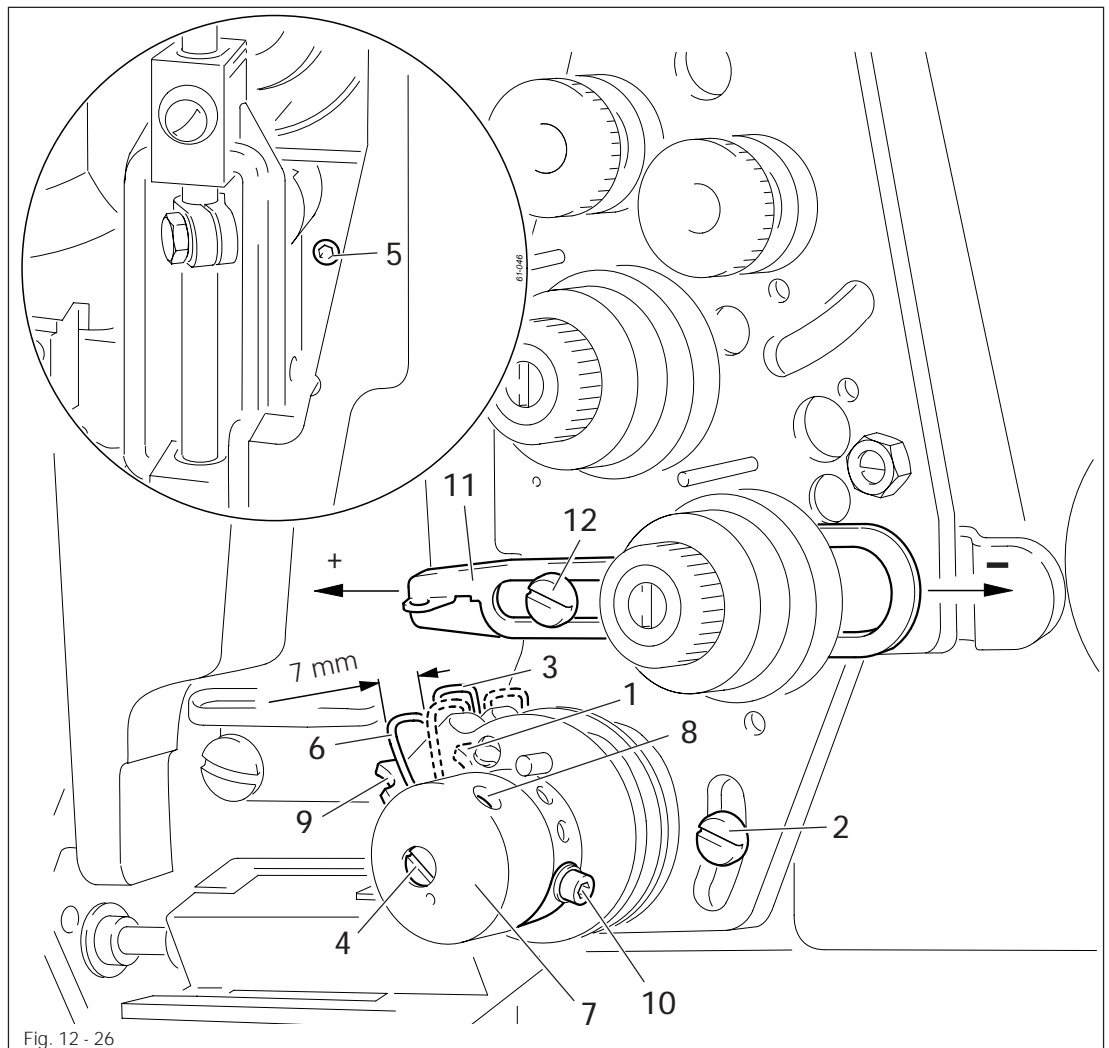
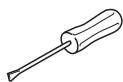

Fig. 12 - 26



- Adjust support **1** (screw **2**) according to **requirement 1**.
- To adjust the spring tension of thread check spring **3** turn screw **4** (screw **5**).
- To adjust the spring tension of thread check spring **6** turn bush **7** (screw **8**).
- Adjust support **9** (screw **10**) according to **requirement 1**. (If the adjustment range is too low, support **9** can be screwed into another hole).
- Adjust the thread regulator **11** (screw **12**) according to **requirement 2**.



For technical reasons it may be necessary to deviate from the specified spring stroke or spring tension.

Move the thread regulator **11** (screw **12**) towards "+" (= more thread) or "-" (= less thread).

12.04.27 Bobbin winder

Requirements

1. When the bobbin winder is engaged, the winding spindle must be driven reliably. When the bobbin winder is disengaged, the friction wheel 5 must not be moved by drive wheel 1.
2. The bobbin winder must switch itself off, when the filled thread is about 1 mm from the edge of the bobbin.

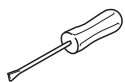
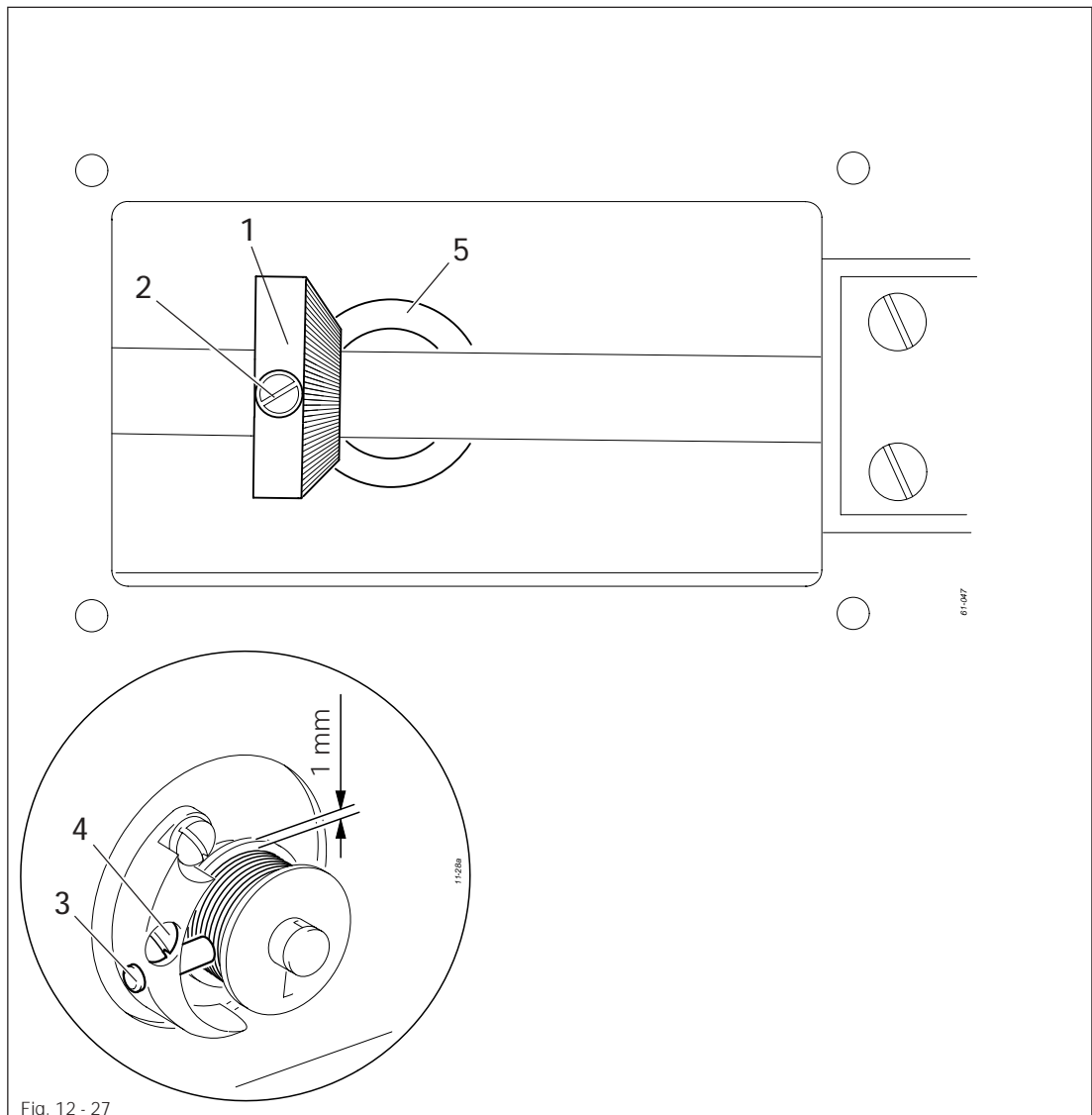

- Position drive wheel 1 (screws 2) according to requirement 1.
- Position bolt 3 (screw 4) according to requirement 2.

12.04.28 Pressure of roller presser

Requirement

The material must be fed smoothly. No pressure marks should be visible on the material.

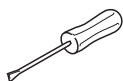
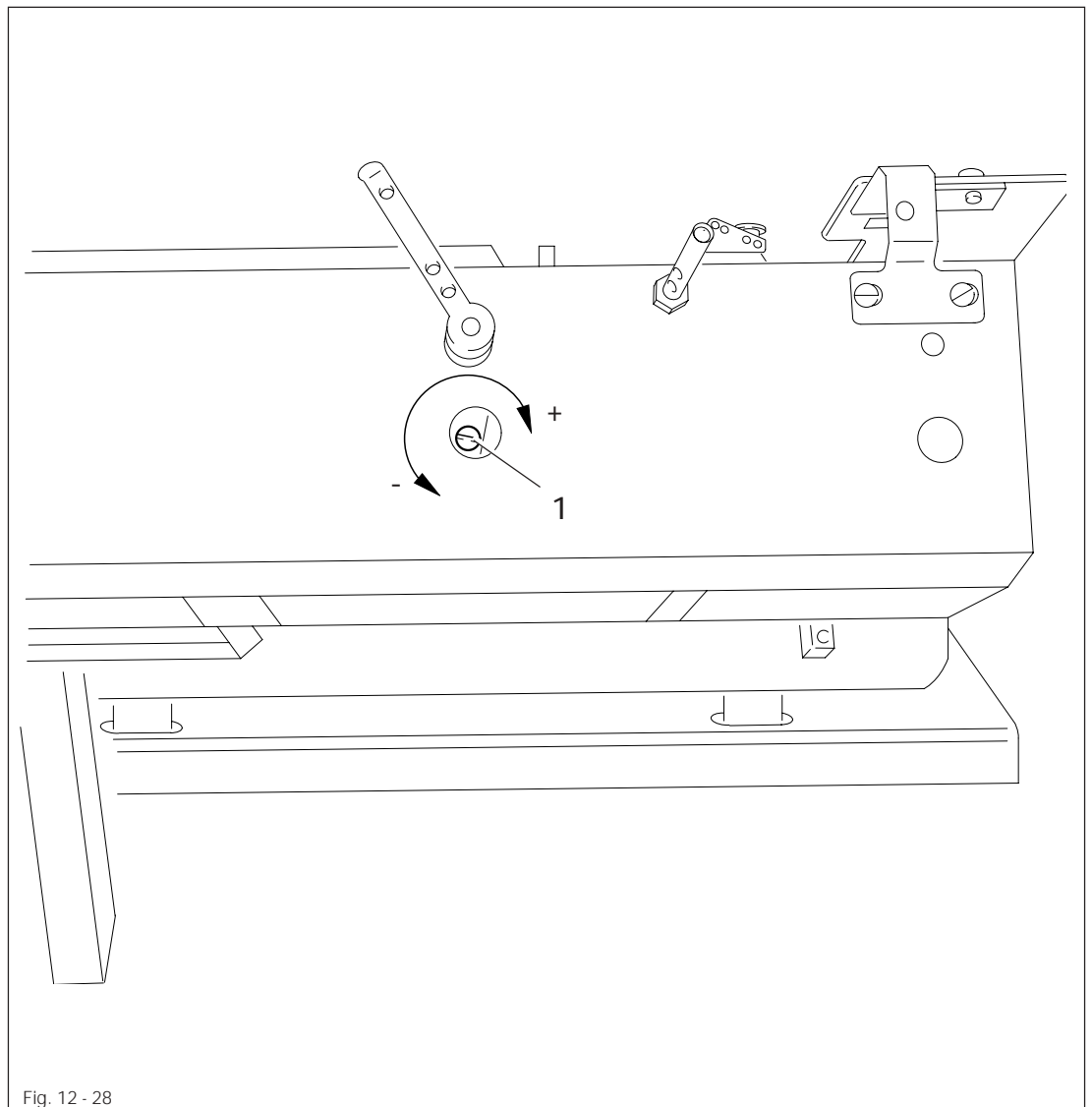

- Adjust roller presser pressure with screw 1 according to the requirement.

12.04.29 Lubrication

Requirement

After a running time of 10 seconds a fine line of oil should form on a strip of paper held next to the hook.

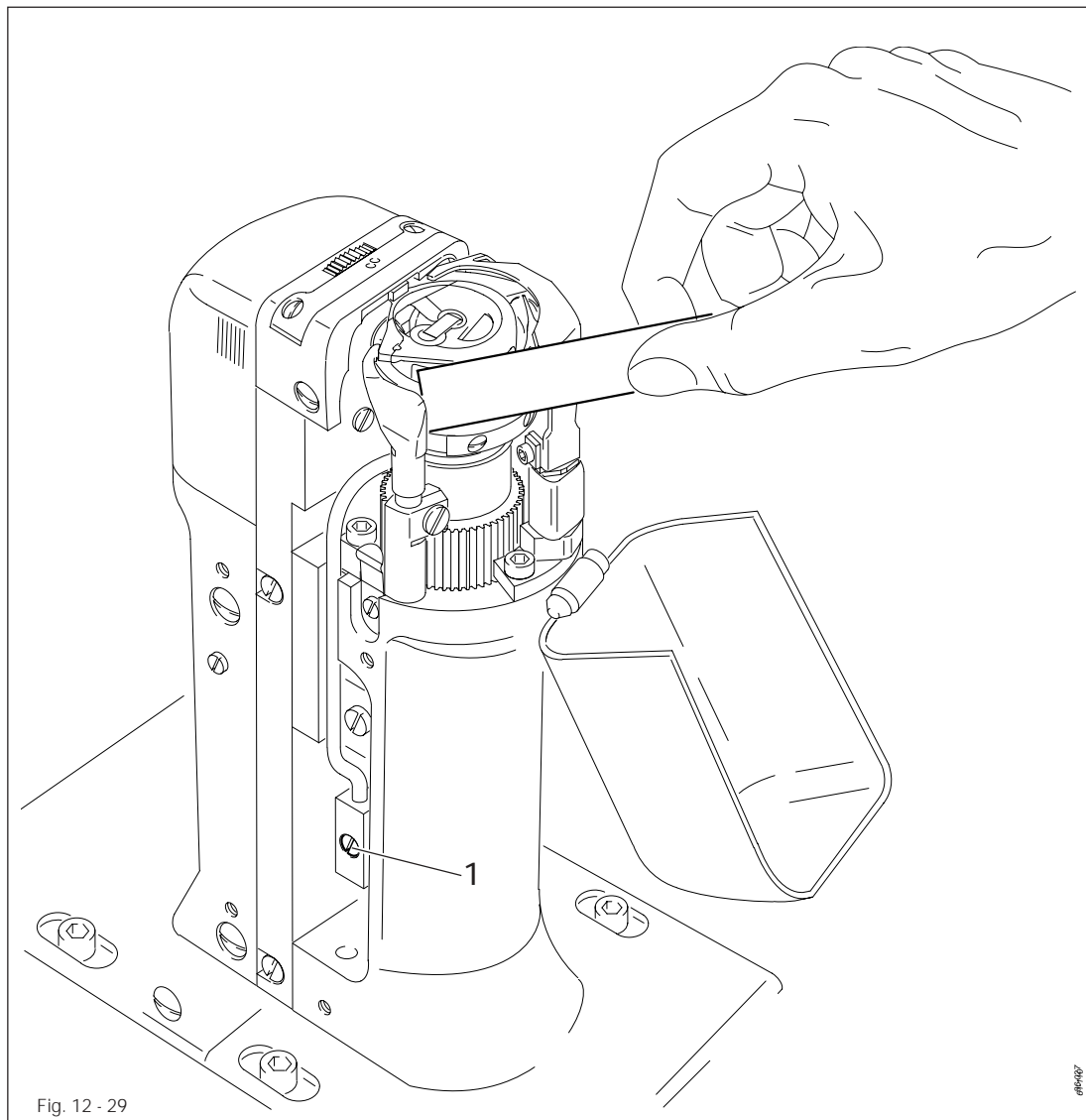
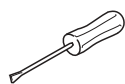

Fig. 12 - 29



- Check whether oil has been filled in and that there is no air in the oil lines.
- Let the machine run for 2-3 min..



While the machine is running do not place hands in the needle or hook area!
Danger of injury from moving parts!

- With the machine running hold a strip of paper on the hook and check the requirement.
- If necessary, adjust the oil flow on screw 1.

12.04.30 Re-engage safety coupling



The coupling 1 is set by the manufacturer. When the thread jams, the coupling 1 disengages in order to avoid damage to the hooks. A description of how to engage the coupling follows.

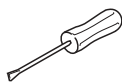
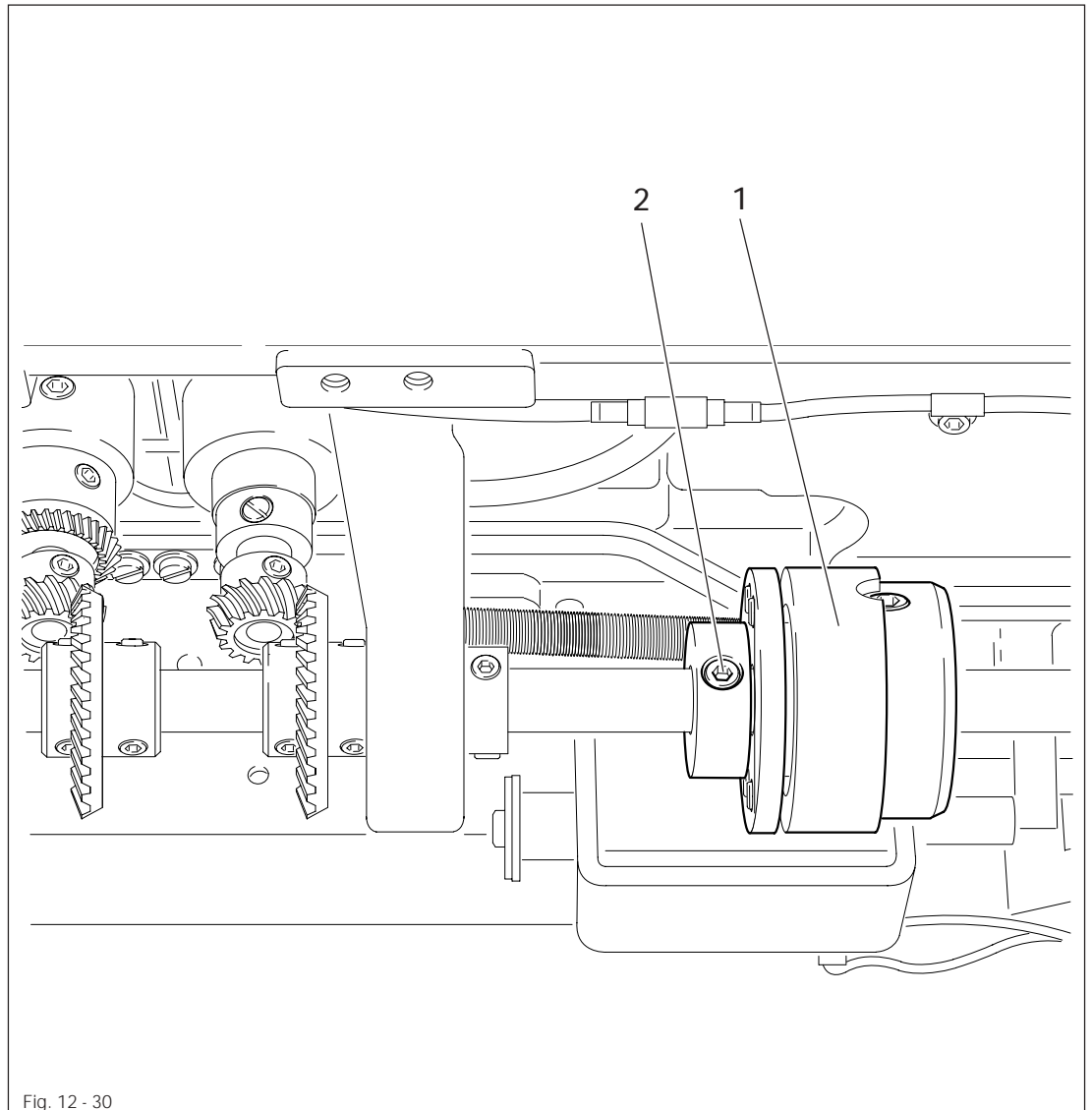

- Remove jammed thread.
- Hold coupling 1 with screw 2 and turn the balance wheel, until you feel coupling 1 snap back into place again.

12.05 Adjusting the edge trimmer -725/04

12.05.01 Position of the knife holder on model 571

Requirements

When the thread trimmer is engaged and the adjusting wheel has been turned to its highest position

1. the knife holder 2 must be parallel to the post and
2. the top edge of the needle plate must be in the centre of the angular knife opening.

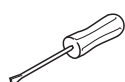
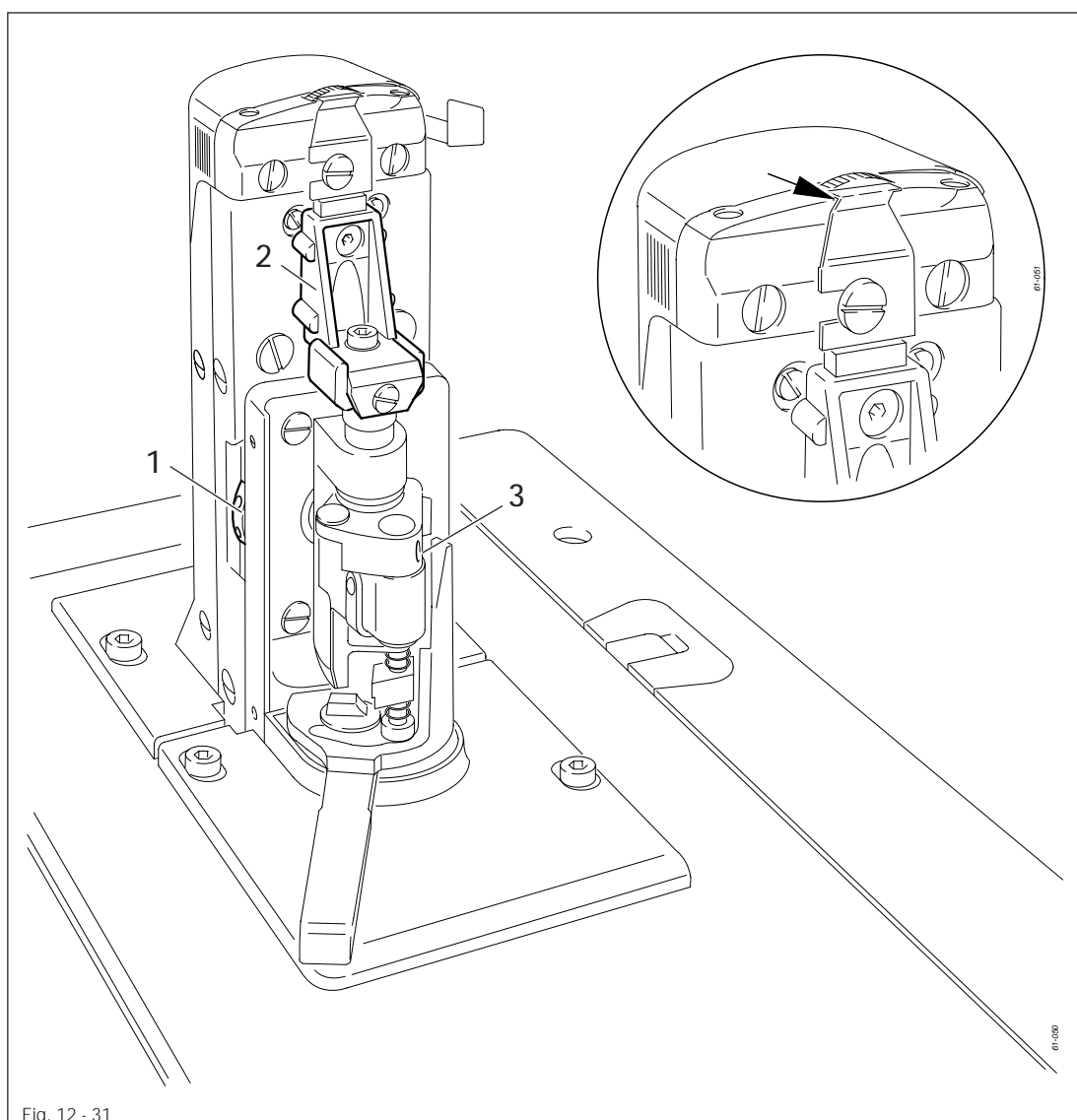

- Turn the adjusting wheel 1 to its highest position and engage edge trimmer.
- Adjust knife holder 2 (screw 3) according to the **requirements**.

12.05.02 Position of the knife holder on models 574 and 591

Requirement

When the thread trimmer is engaged, the centre of the angular knife opening must be level with the top edge of the needle plate.

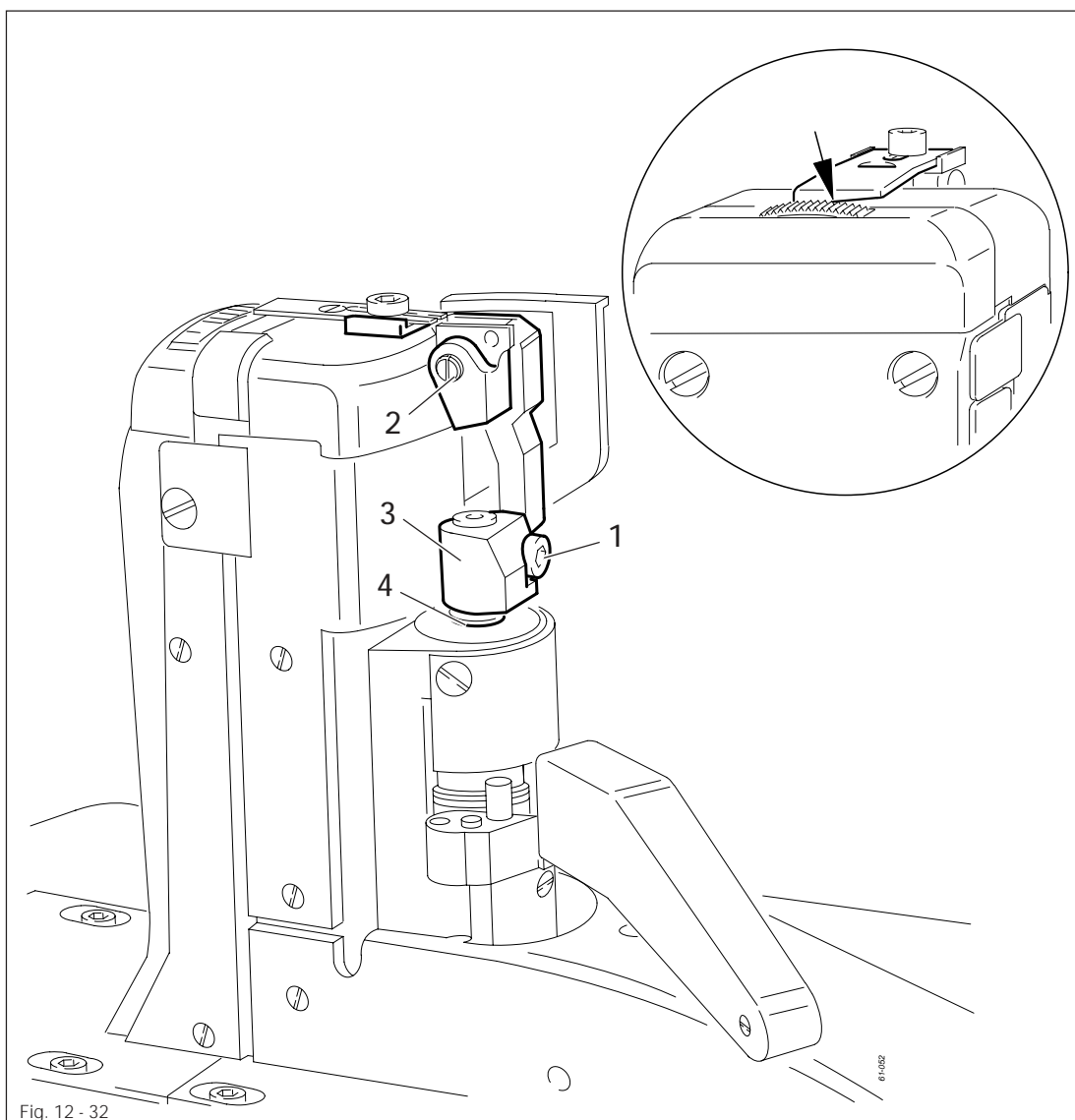
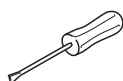

Fig. 12 - 32



- Switch off the machine and engage the edge trimmer.
- Loosen screw 1.
- By turning eccentric 2, position the knife in the centre of its adjustment range.
- Adjust knife holder 3 according to the **requirement** and tighten screw 1.
- Position locking ring 4 on the knife holder 3.



Depending on the material thickness, changes in the basic setting of eccentric 2 are possible.

Adjustment

12.05.03 Knife stroke on model 571

Requirement

The knife stroke can be adjusted over a range from 1.0 to 3.5 mm, allowing the best possible adaption to all materials used.

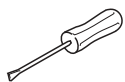
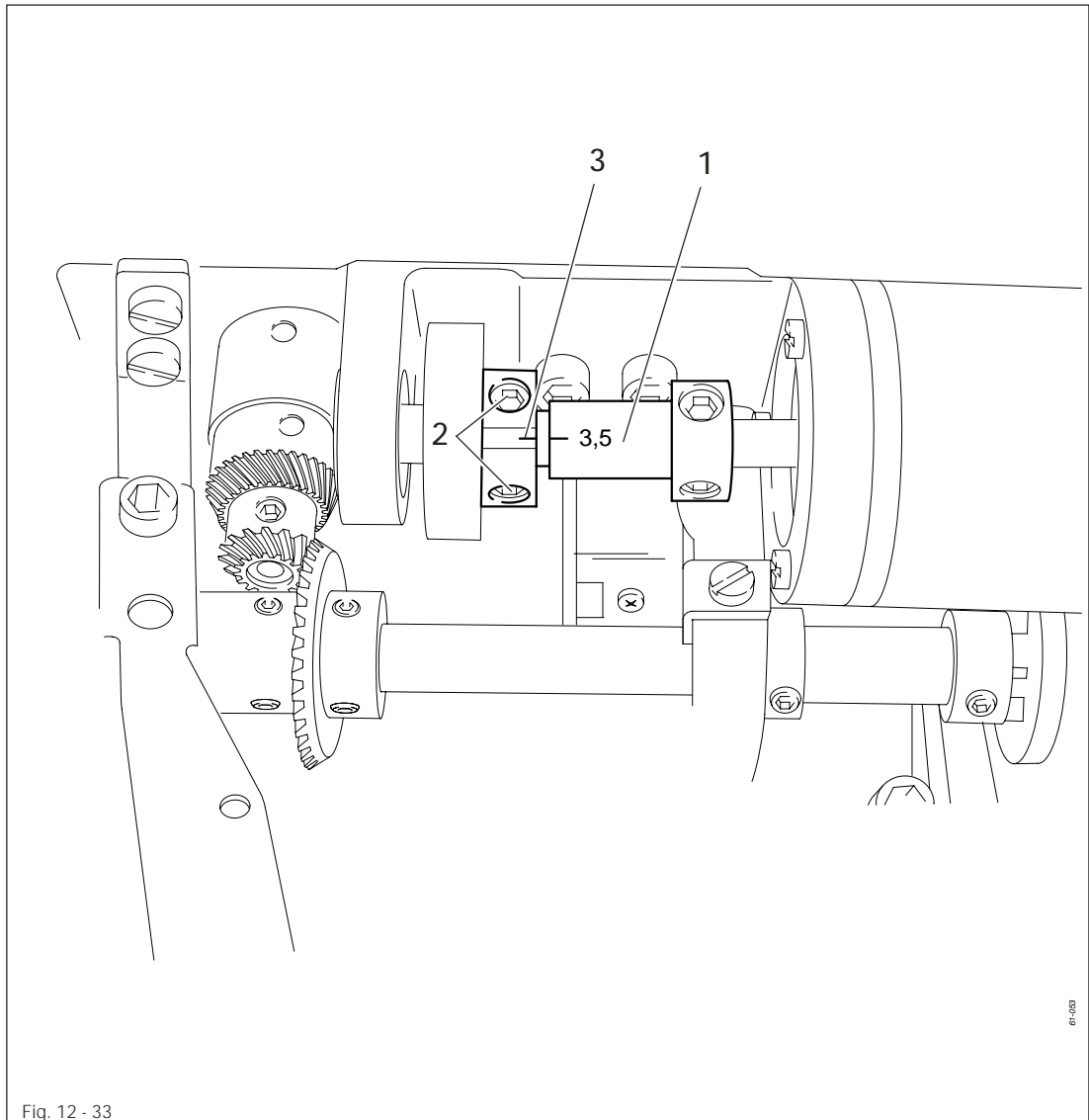

- Turn eccentric 1 (screws 2) so that the marking of the desired cutting stroke is opposite the marking on clamp collar 3.

12.05.04 Knife stroke on models 574 and 591

Requirement

The knife stroke can be adjusted over a range from 2.0 to 3.5 mm, allowing the best possible adaption to all materials used.

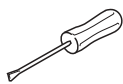
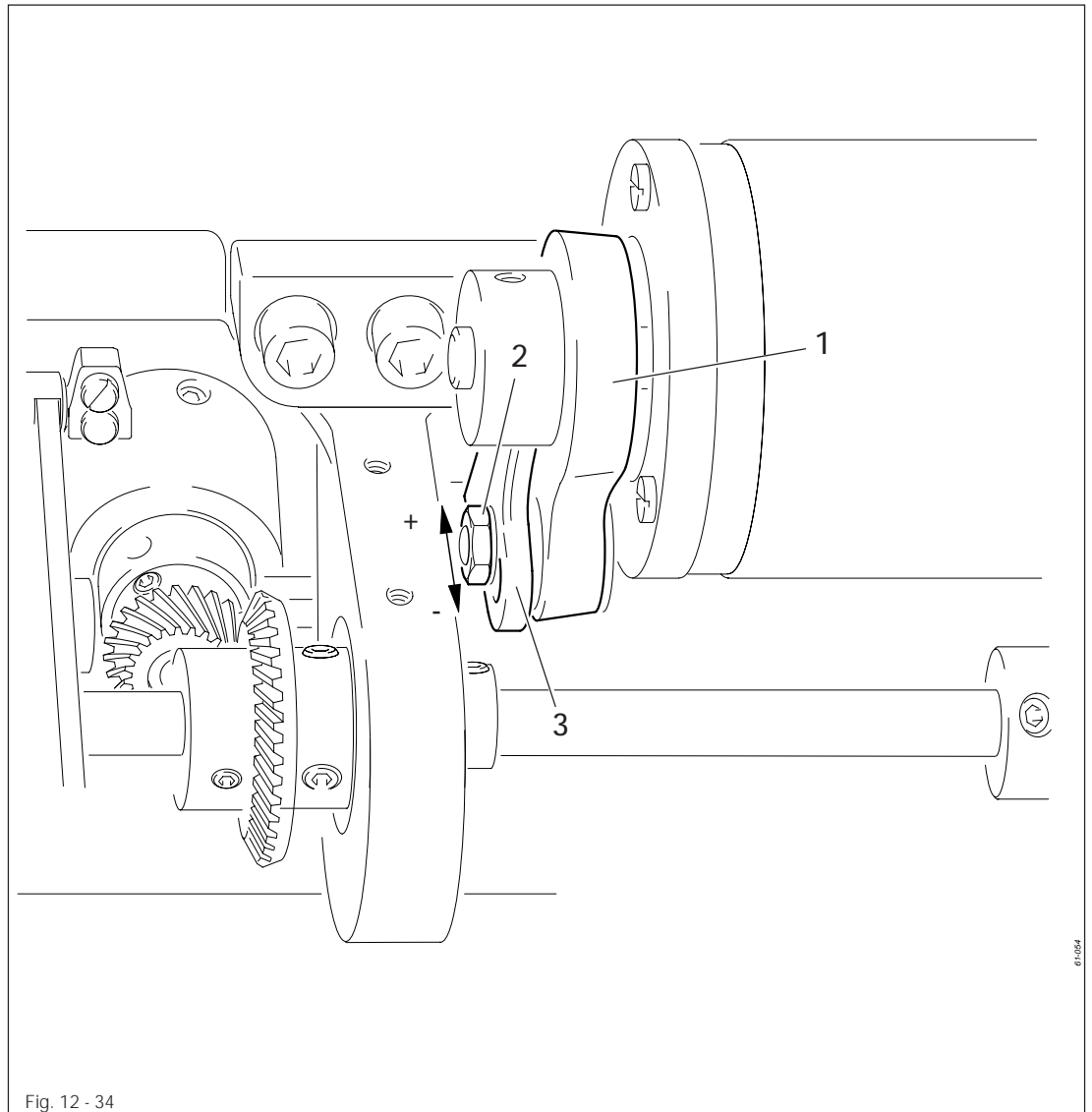

- Adjust crank 1 (nut 2) in slotted lever 3 according to the requirement.

Adjustment

12.05.05 Cutting stroke on model 571

Requirement

When the edge trimmer is engaged and the needle is in the needle hole, the stroke of knife 1 should be half in front of and half behind the needle, when the motor shaft is turned by hand.

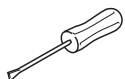
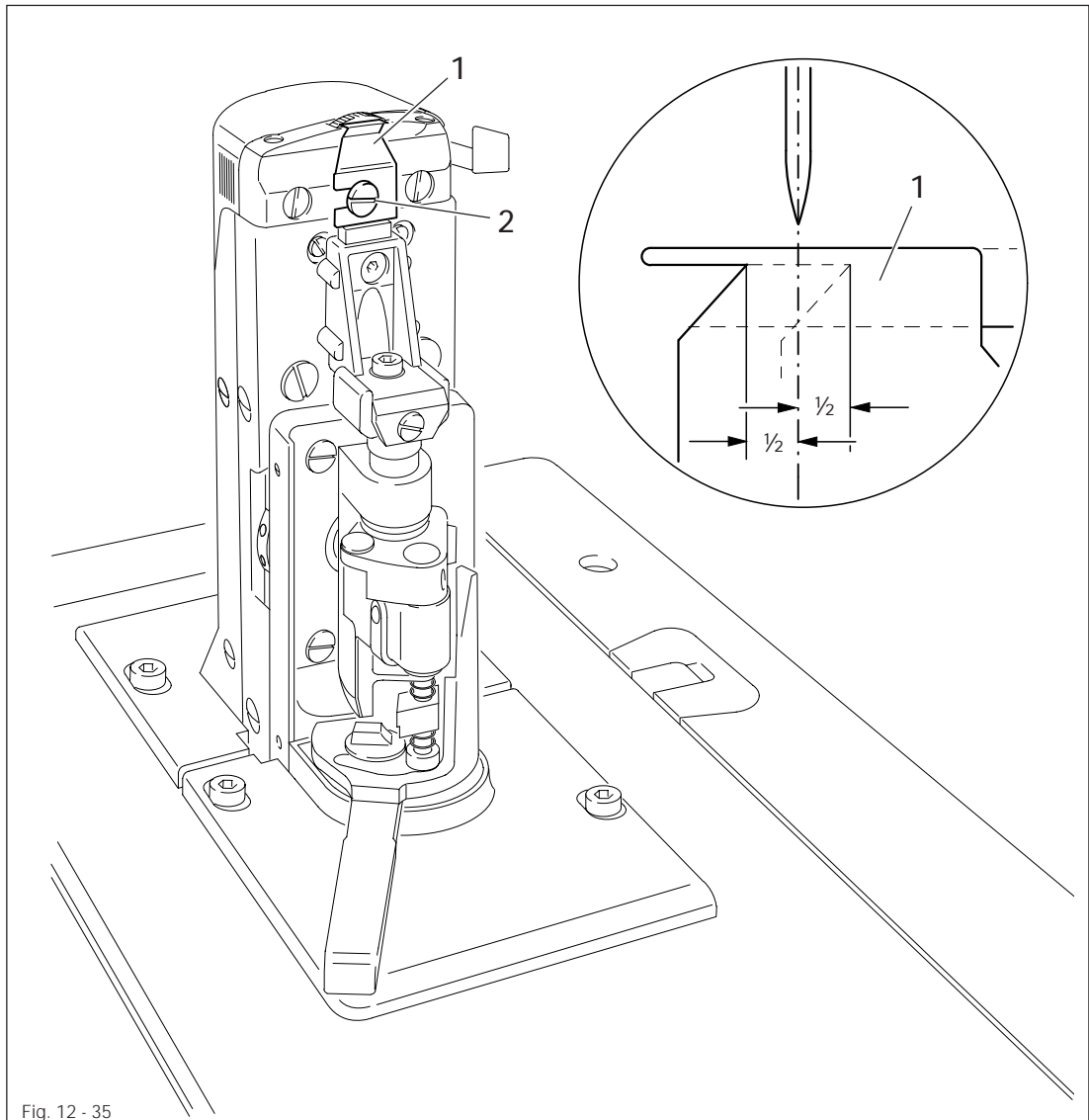

- Switch off the machine and engage the edge trimmer.
- Adjust knife 1 (screw 2) according to the requirement.

12.05.06 Cutting stroke on models 574 and 591

Requirement

When the edge trimmer is engaged and the needle is in the needle hole, the stroke of knife 3 should be half in front of and half behind the needle, when the motor shaft is turned by hand.

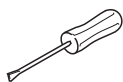
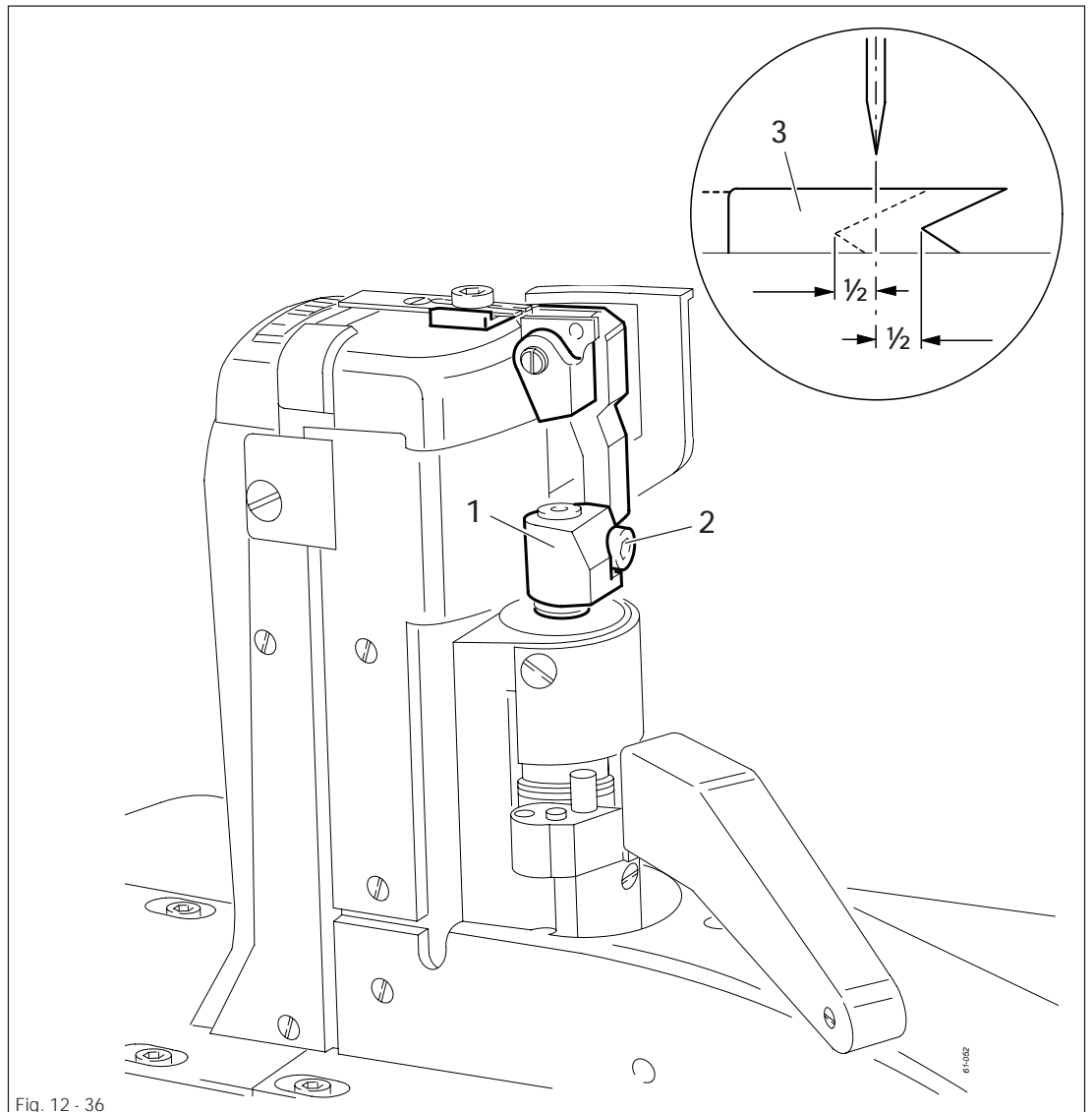

- Switch off the machine and engage the edge trimmer.
- Adjust knife holder 1 (screw 2) according to the requirement.

12.05.07 Knife position

Requirement

When the edge trimmer is engaged, the knife should rest lightly on the needle plate insert, but no whistling sound should occur during trimming.

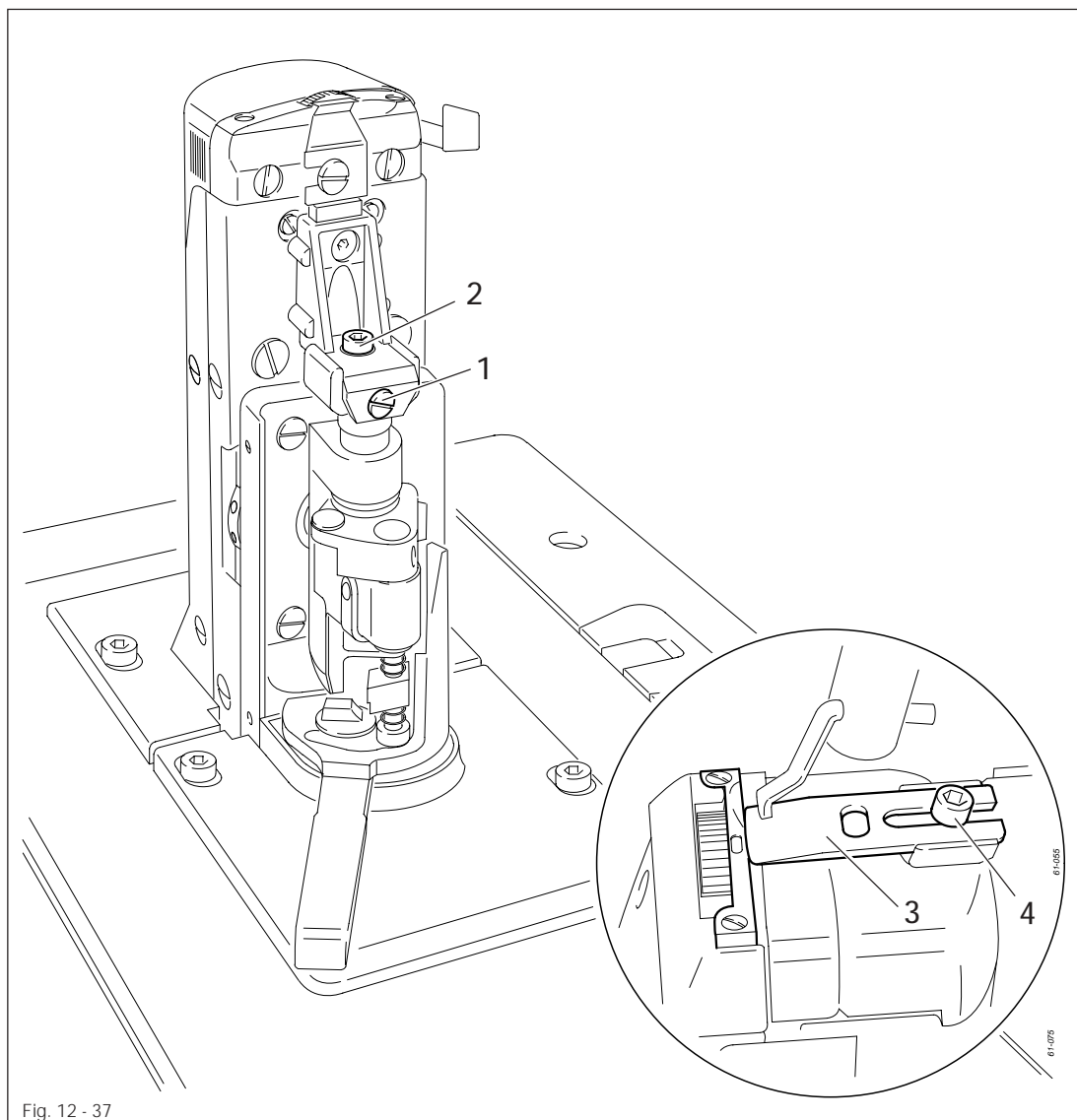

571

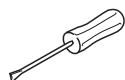

- Adjust screw 1 (screw 2) according to the requirements.
- Carry out a cutting test and repeat adjustment if necessary.

574 and 591

- Adjust knife 3 (screw 4) according to the requirements.
- Carry out a cutting test and repeat adjustment if necessary.

12.06 Adjusting the thread trimmer -726/05 on model 591

12.06.01 Position of the knife to the needle plate

Requirement

When the edge trimmer is engaged, the knife 2 must be parallel to the needle plate insert.

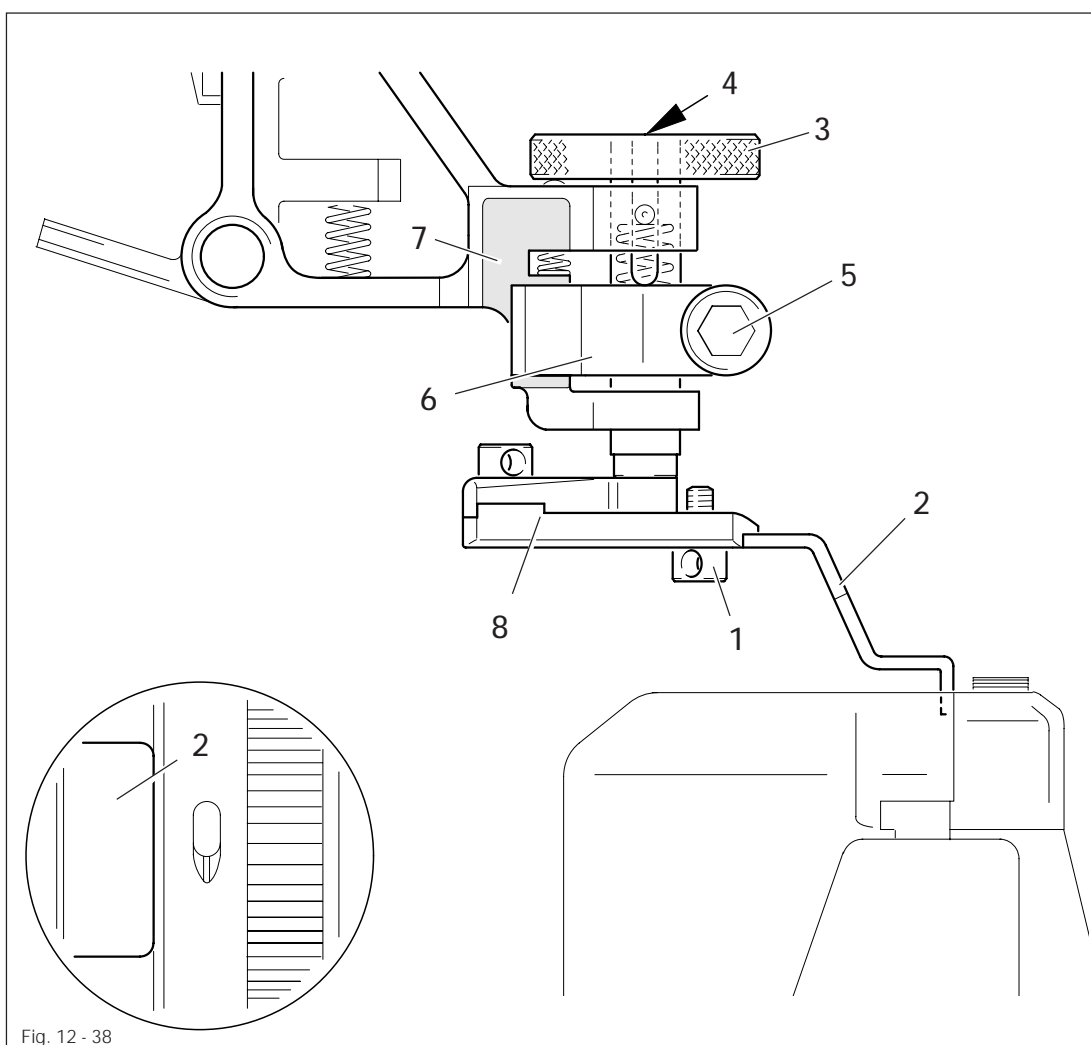
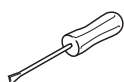

Fig. 12 - 38



- Switch off the machine and engage the edge trimmer.
- Loosen screw 1 and push back knife 2 slightly.
- Turn milled screw 3 until its top edge is flush with the top edge of the cylindrical guide 4.
- Loosen screw 5, position guide 6 in the centre of guide 7 and slightly tighten screw 5.
- Adjust knife holder 8 according to the requirement and tighten screw 5.

Screw 1 remains loosened for further adjustments.



12.06.02 Knife position crosswise to sewing direction

Requirement

When the edge trimmer is engaged, knife 2 must be vertical and rest lightly on the needle plate insert.

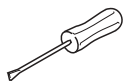
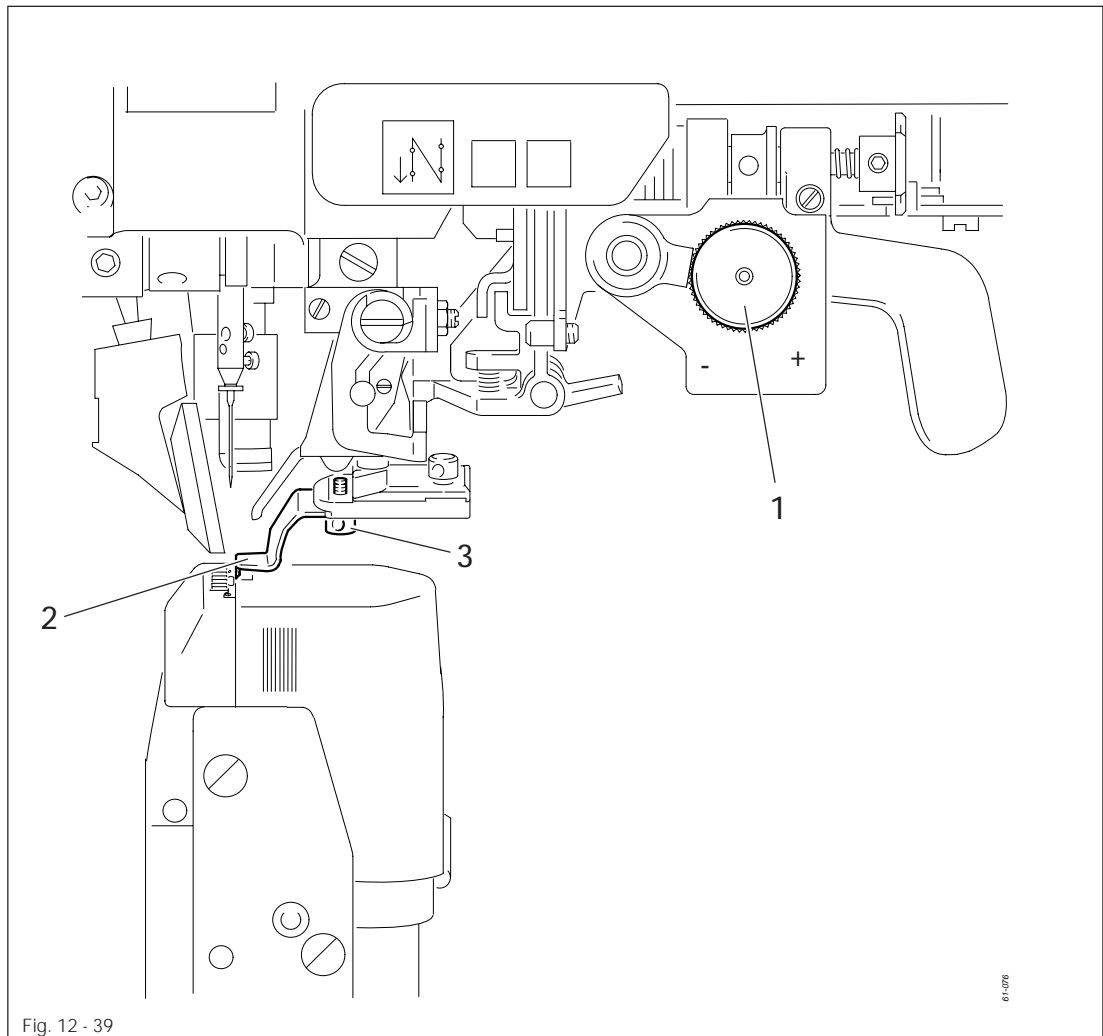

- Switch off the machine and engage the edge trimmer.
- Bring the knife into a vertical position by turning milled screw 1.
- Bring knife 2 into light contact with the needle plate insert and tighten screw 3.



The cutting pressure can be adapted to the material used with milled screw 1.

12.06.03 Knife height

Requirement

When the edge trimmer is engaged, the centre of the angular knife opening must be at the same height as the upper edge of the needle plate.

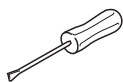
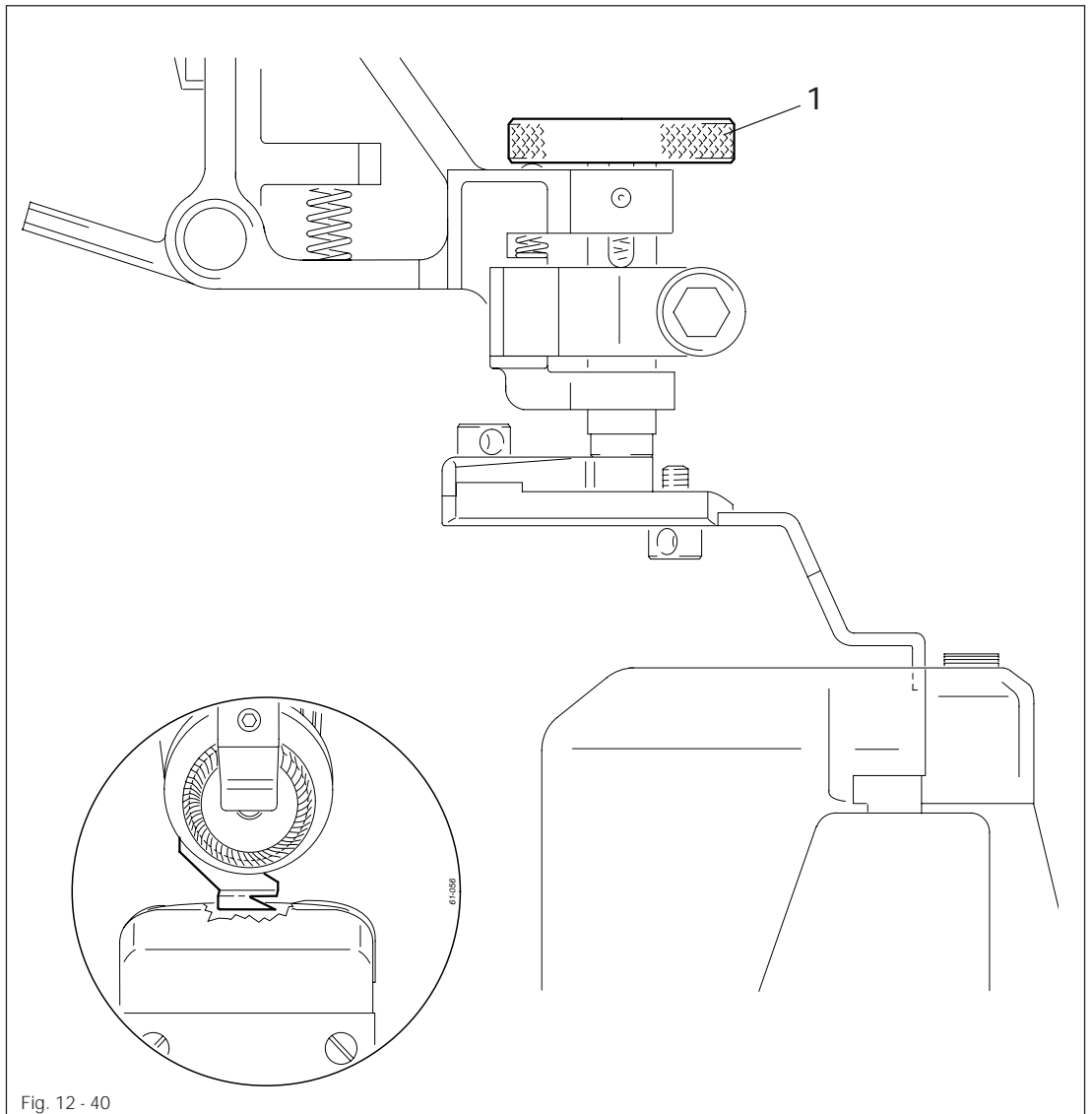

- Switch off the machine and engage the edge trimmer.
- Adjust milled screw 1 according to the requirement.



The basic setting may be changed depending on the material thickness.

12.06.04 Cutting stroke

Requirement

When the edge trimmer is engaged and the needle is in the needle hole, the stroke of knife 3 should be half in front of and half behind the needle, when the motor shaft is turned by hand.

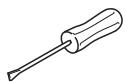
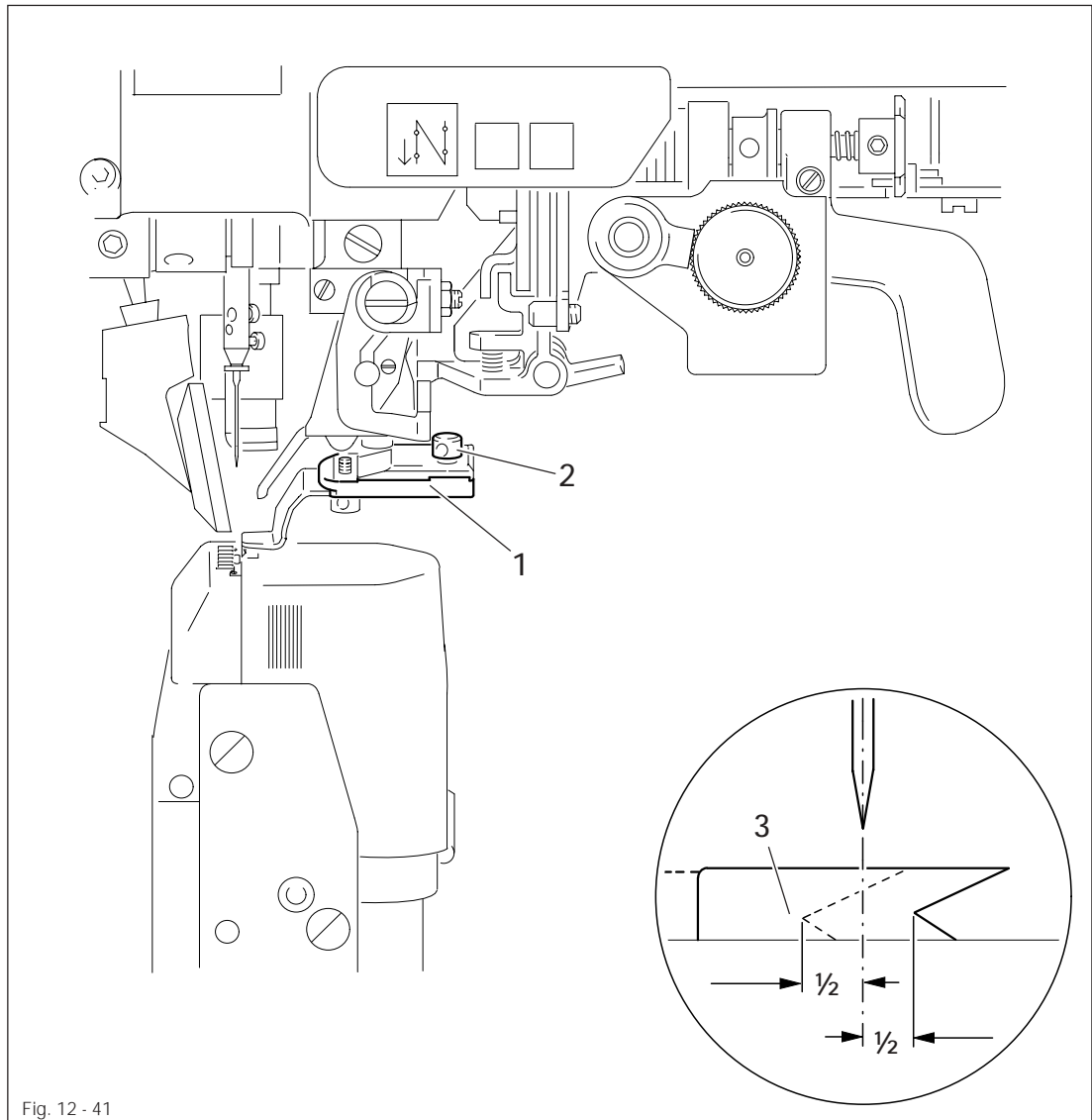

- Switch off the machine and engage the edge trimmer.
- Adjust knife holder 1 (screw 2) according to the requirement.

12.06.05 Knife stroke

Requirement

The knife stroke can be adjusted over a range from 1.0 to 3.5 mm, allowing the best possible adaption to all materials used.

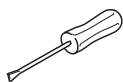
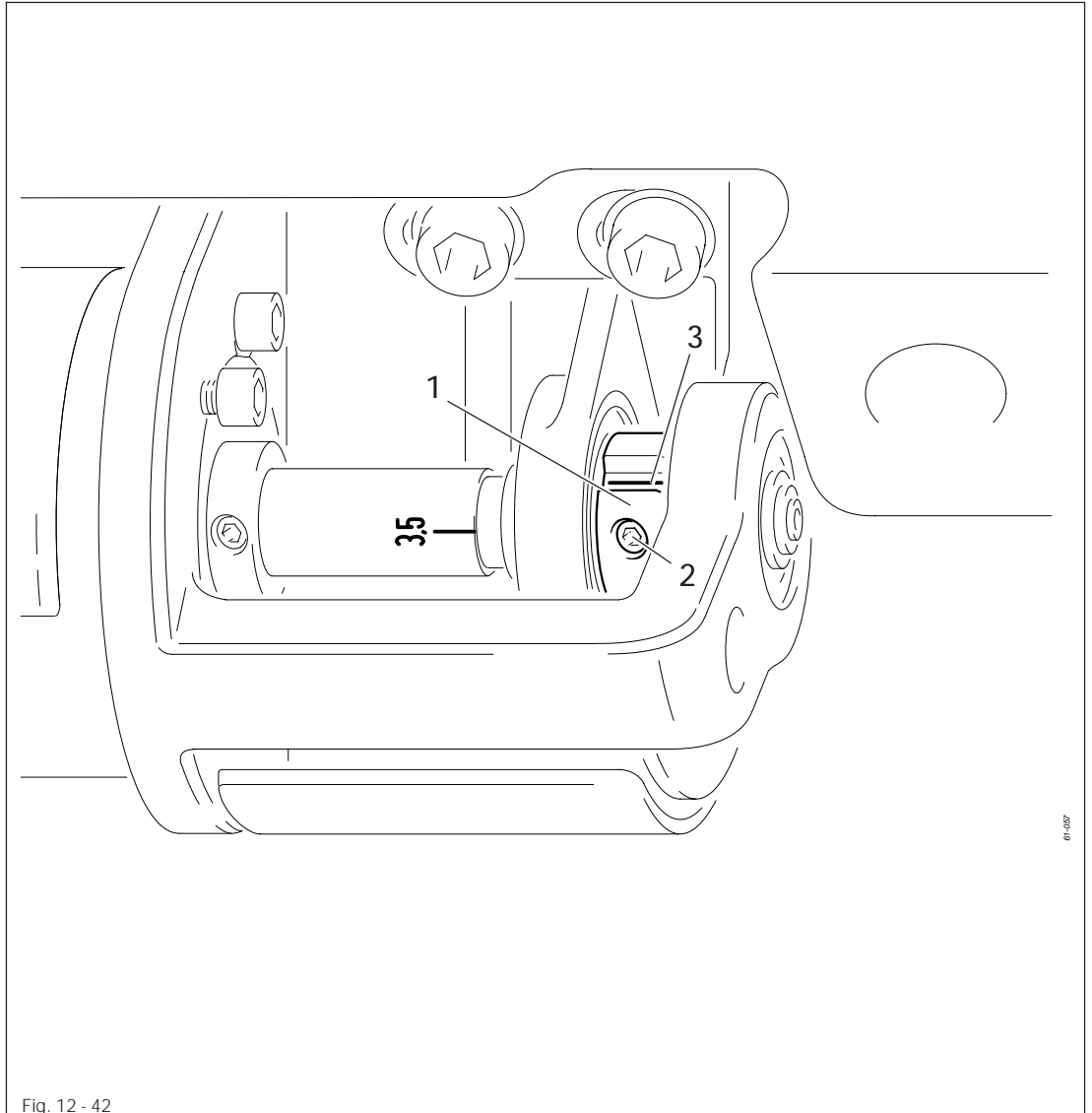

- Turn eccentric 1 (screws 2) on the back of the sewing head so that the marking of the desired cutting stroke is opposite marking 3.

12.07 Adjusting the thread trimmer -900/81

12.07.01 Resting position of the roller lever / radial position of the control cam

Requirement

1. When the thread trimmer is in its resting position, lever 5 should be touching piston 6 and the roller of roller lever 7 should be 0.3 mm away from control cam 3.
2. When the take-up lever is at t.d.c., control cam 3 should just have placed roller lever 7 in its resting position.

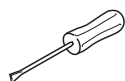
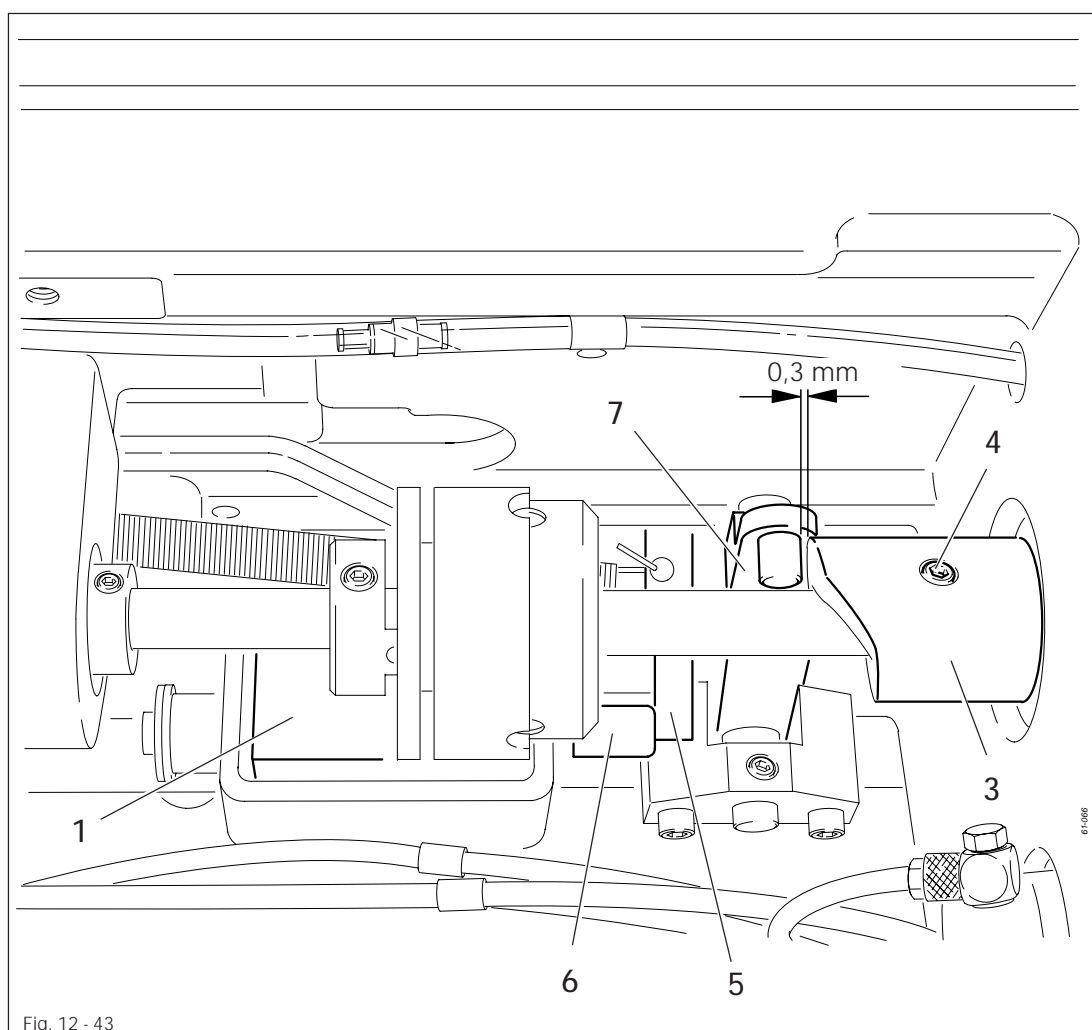

- Having made sure that piston 6 is positioned against the left stop, adjust magnet 1 (2 screws) in accordance with requirement 1.
- Adjust control cam 3 (screws 4) in accordance with requirement 2.

12.07.02 Position of the thread catcher holder

Requirement

1. There should be a minimum amount of play between toothed wheel 3 and toothed segment 4.
2. Both in the neutral position and the foremost position of the catcher, the distance between the toothed segment 4 and the outer edge of the thread catcher holder 1 should be the same (see arrow).

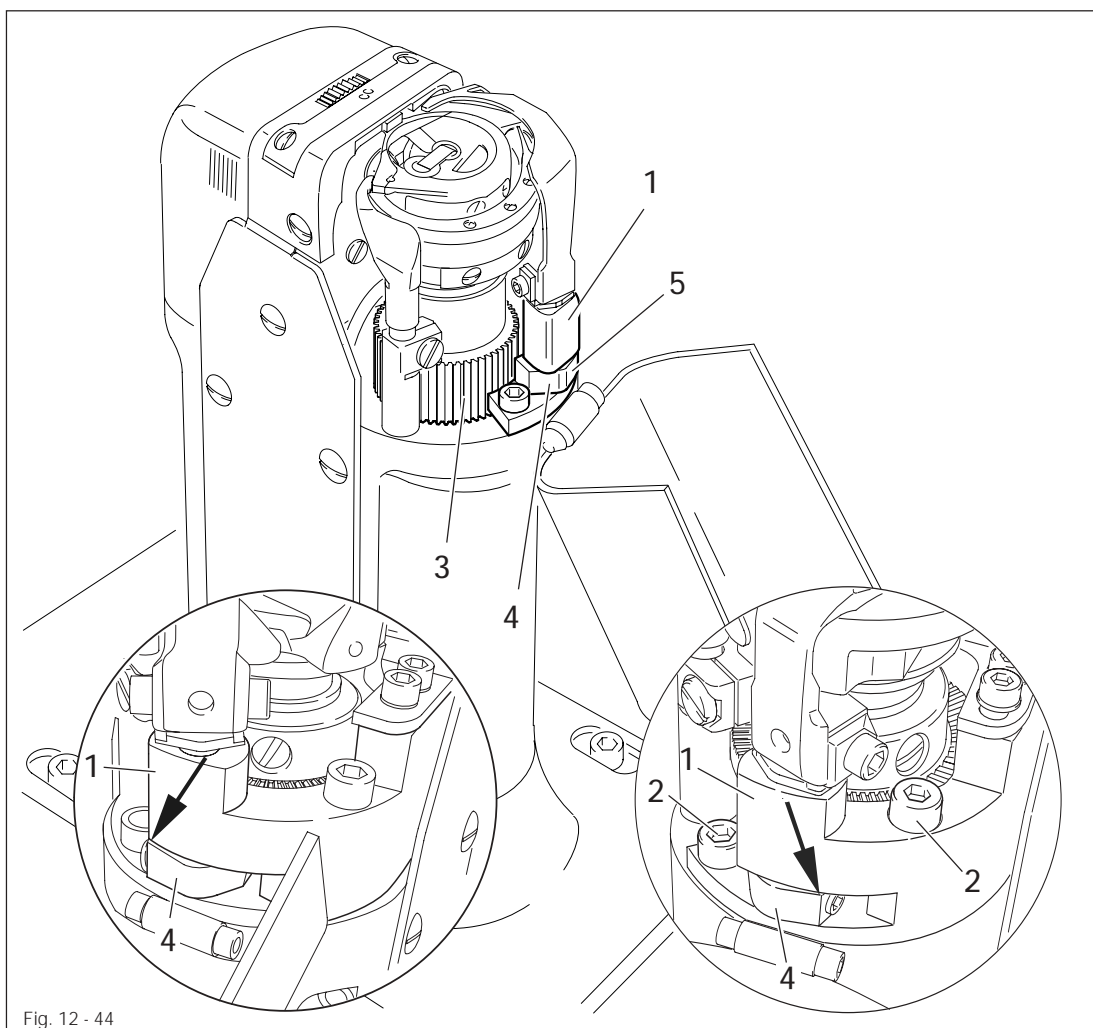
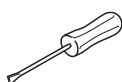

Fig. 12 - 44



- Adjust the thread catcher holder 1 (screws 2) according to the requirements.



If requirement 2 cannot be fulfilled, loosen screw 2 and move the toothed segment 4 by one tooth.

Adjustment

12.07.03 Distance between thread catcher and needle plate

Requirement

During its swivel movement thread catcher 1 should not pass the edge of the needle plate (see arrow).

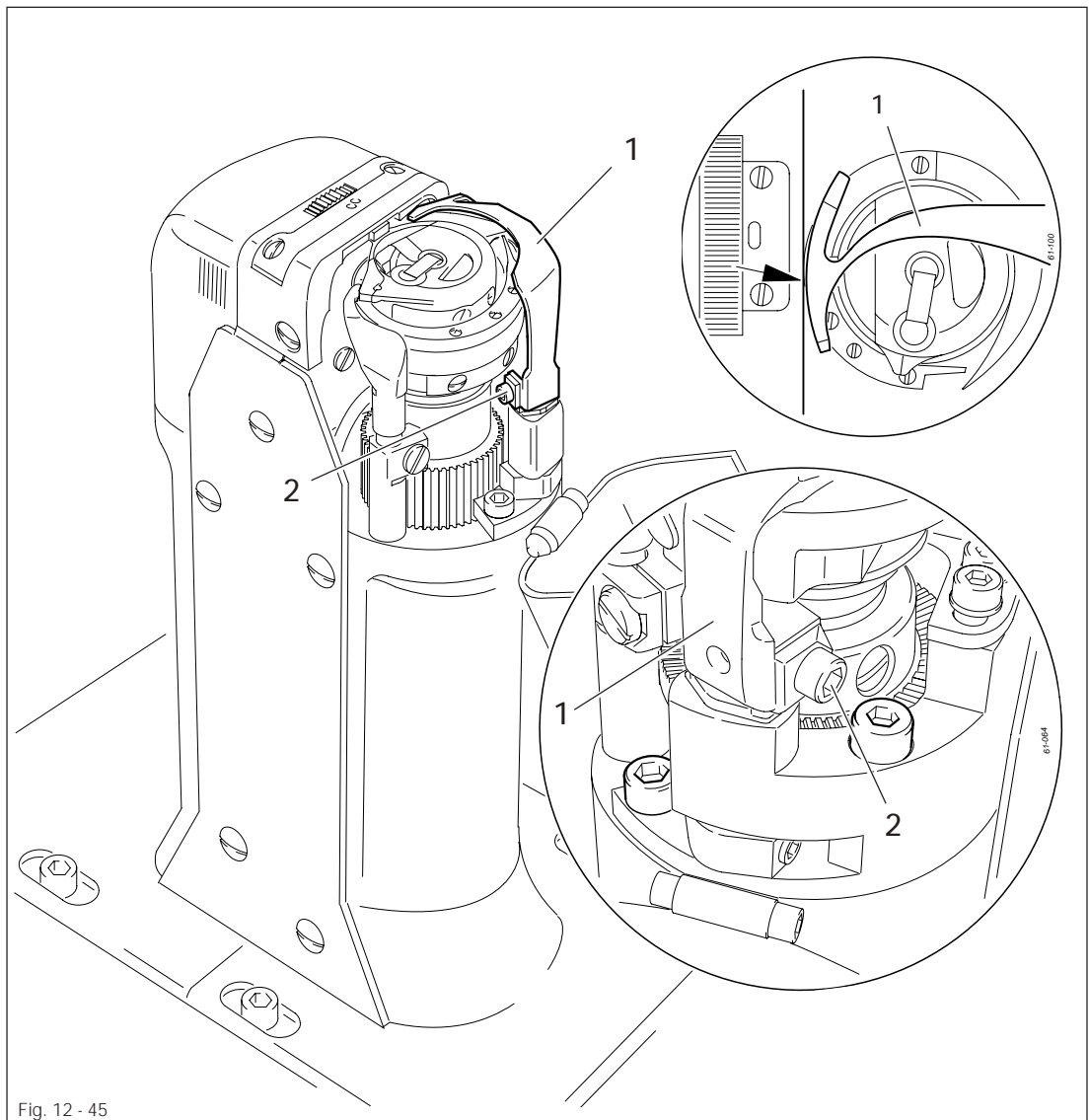
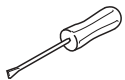

Fig. 12 - 45



- Move thread catcher 1 (screws 2, two screws) parallel to the thread catcher holder in accordance with the requirement.

12.07.04 Position of the thread catcher

Requirement

1. The bottom edge of the thread catcher 1 should be at a distance of 0.1 mm from the positioning finger of the bobbin case 5.
2. When the thread trimmer is in its neutral position, the rear edge of thread catcher 1 should be positioned approx. 2.5 – 3 mm behind the edge of the knife.

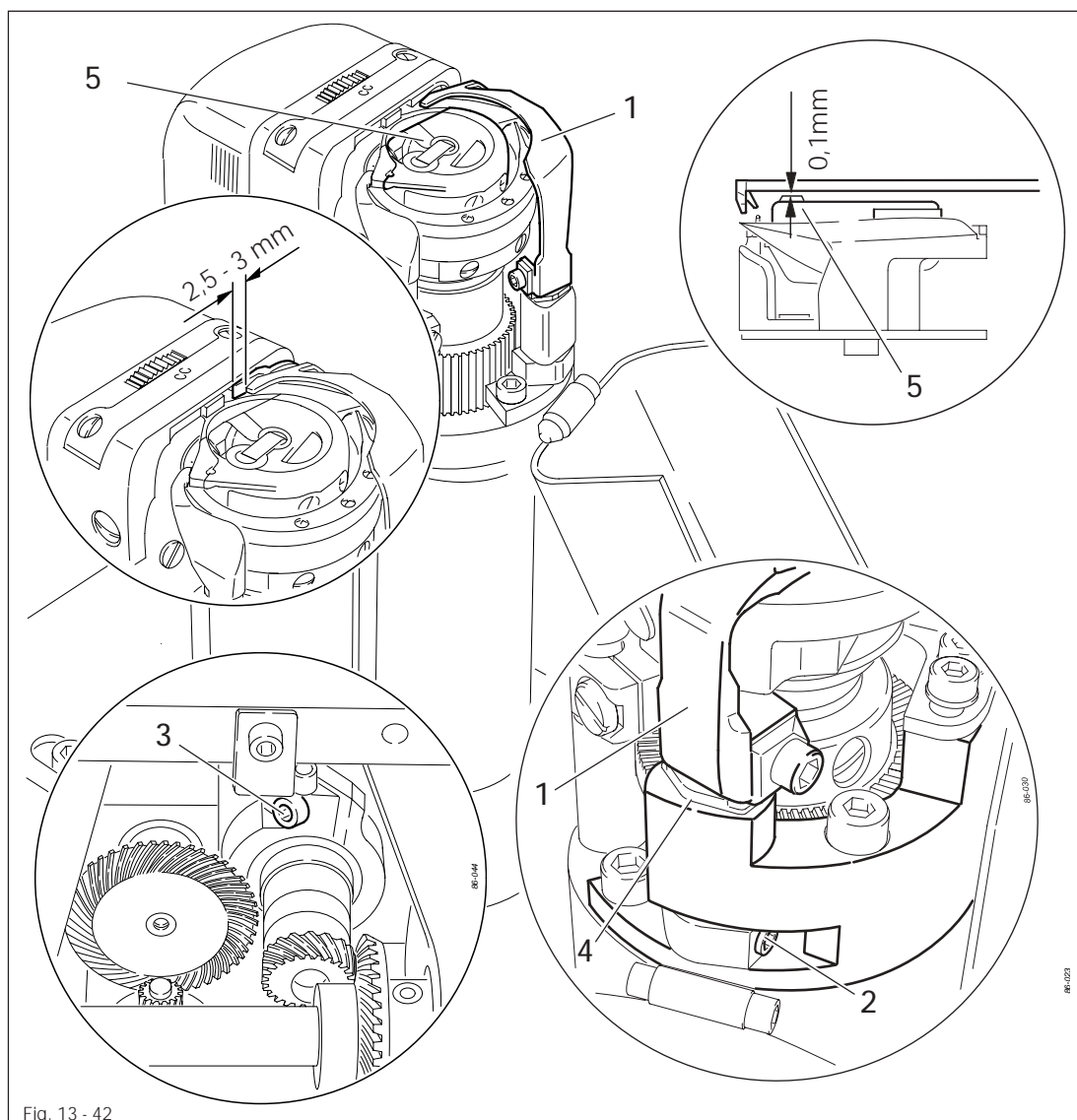
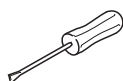

Fig. 13 - 42



- Move thread catcher 1 (screws 2, two screws) in accordance with requirement 1.
- Turn thread catcher 1 (screw 3) in accordance with requirement 2.



Thread catcher 1 must be parallel to the surface of the thread catcher holder 4.

Adjustment

12.07.05 Knife position and knife pressure

Requirement

1. The knife 1 should be touching the needle plate.
2. The knife pressure should be set as low as possible but the cutting operation should still be carried out reliably.

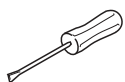
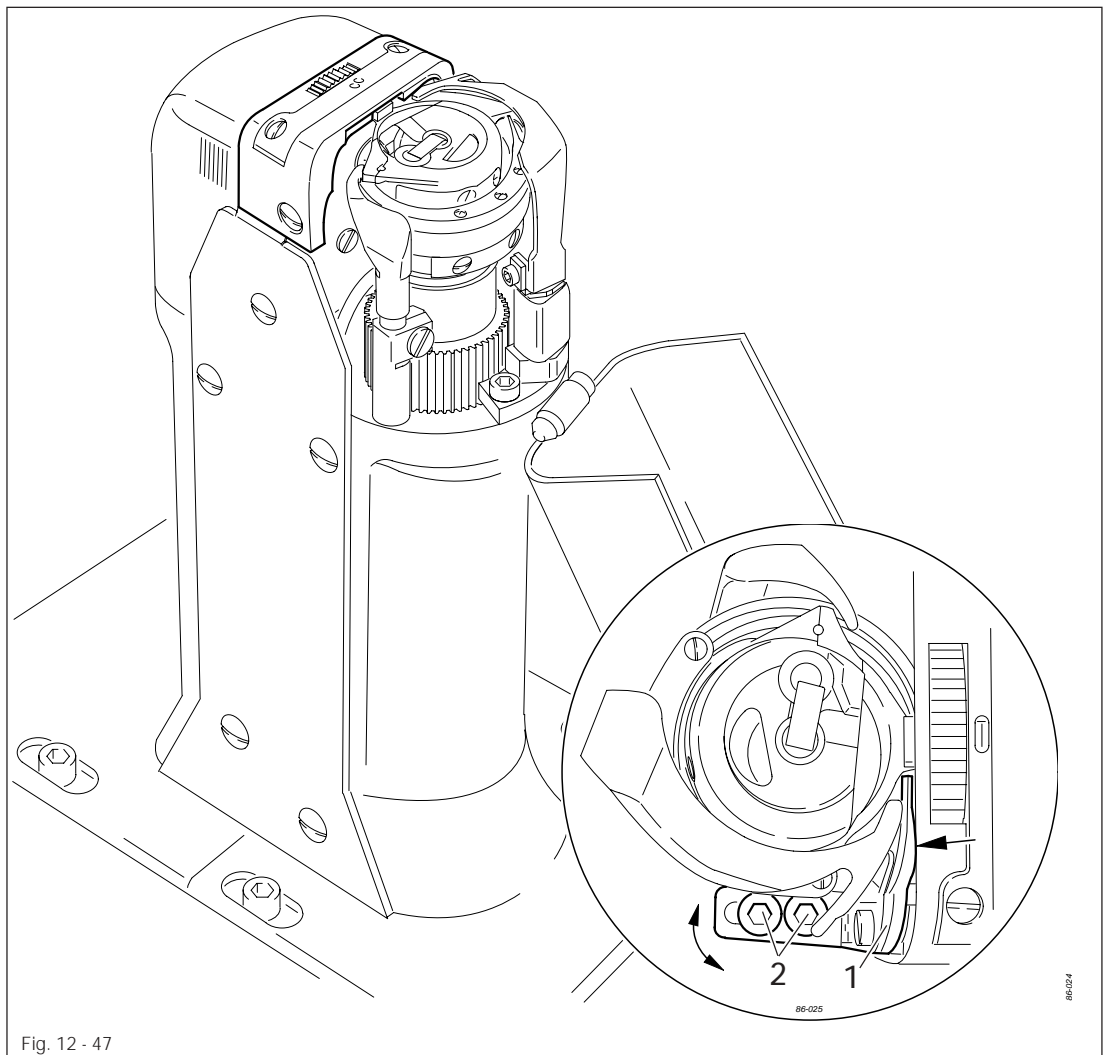

- Move knife 1 (screws 2) in accordance with requirement 1 or swivel it in accordance with requirement 2.

12.07.06 Bobbin thread retaining spring

Requirement

1. The bobbin thread clamp spring should be guided reliably in the thread groove of the thread catcher 3.
2. The tension of the bobbin thread spring clamp should be as low as possible, but the bobbin thread should be held reliably after the cutting operation.

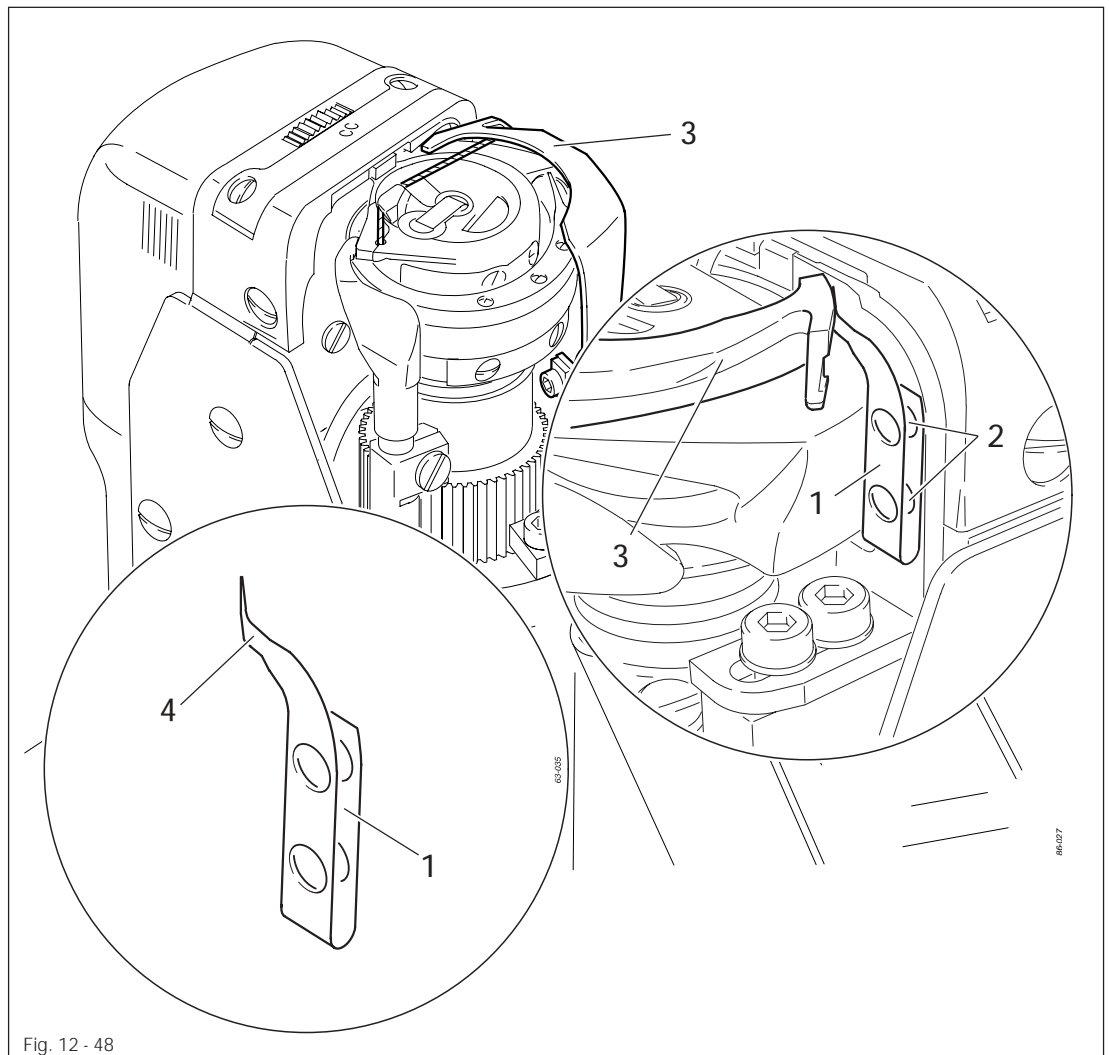
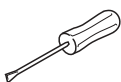

Fig. 12 - 48



- Adjust bobbin thread clamp spring 1 (screws 2) in accordance with **requirement 1**.
- Adjust the tension in accordance with **requirement 2** by bending side 4 of the bobbin thread clamp spring 1.

Control – requirement 1

- Switch off the machine and bring the take-up lever to its b.d.c.
- Engage and disengage the thread catcher 3 by hand and check **requirement 1**. Adjust if necessary.

Control – requirement 2

- After the thread has been cut, sew a few stitches by turning the balance wheel, checking whether the bobbin thread is drawn out of the bobbin thread clamp spring between the 1st and 3rd stitches. If necessary, correct the tension.

12.07.07 Manual cutting test

Requirement

1. When thread catcher 1 is on its forward stroke, it must not carry bobbin thread 3 forward too.
2. When thread catcher 1 is in its front position, bobbin thread 3 must be held reliably by hook 4.
3. After the trimming action, both the needle thread and the bobbin thread must be perfectly cut and bobbin thread 3 retained.

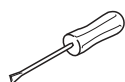
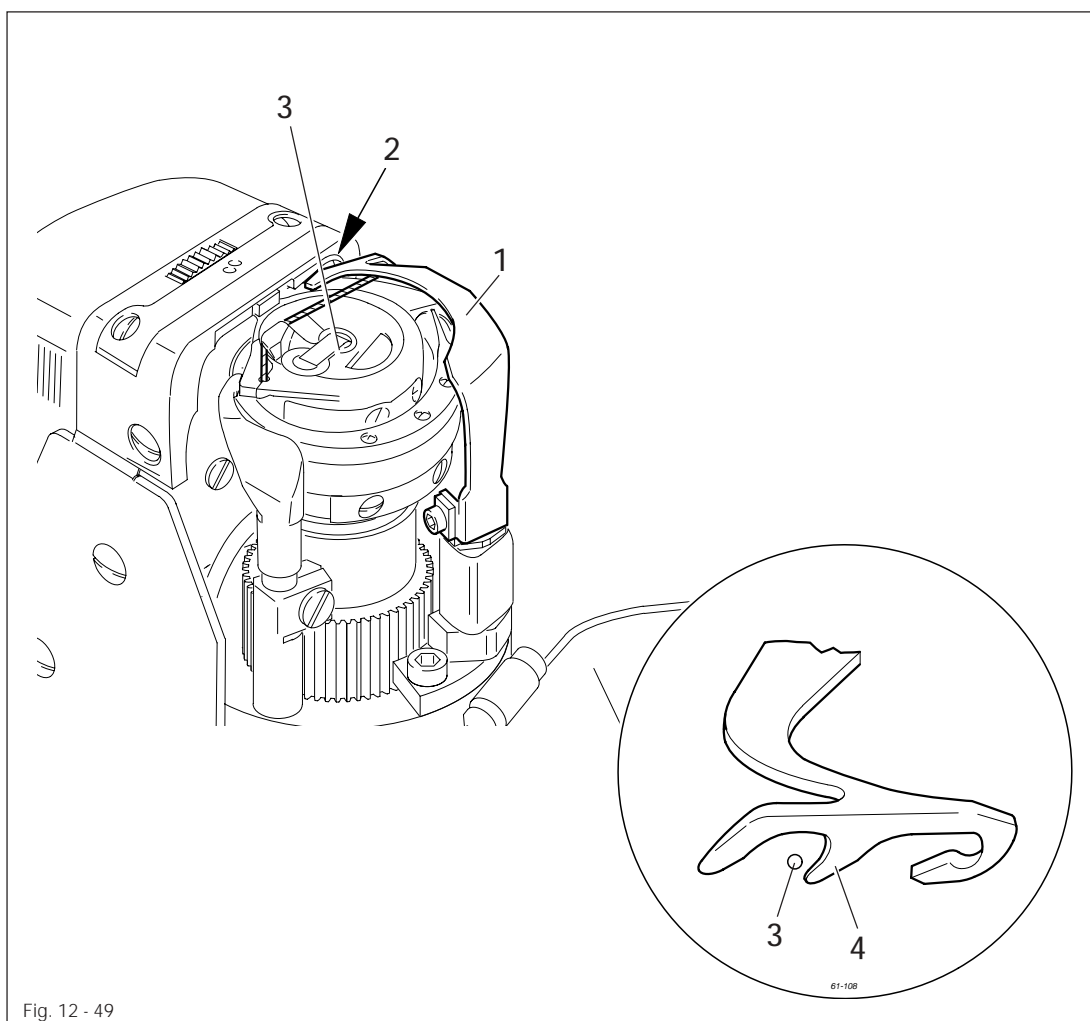

- Sew a few stitches.
- Turn off the on/off switch.
- Carry out the cutting operation manually.
- Check **requirement 1** and **2**, and if necessary readjust thread catcher **1** in accordance with **Chapter 12.07.04 Position of the thread catcher**.
- Check **requirement 3**, and if necessary readjust the bobbin thread retaining spring **2** in accordance with **Chapter 12.07.06 Bobbin thread retaining spring**.

12.07.08 Releasing the tension

Requirement

When the magnet is activated, tension discs 3 must be at least 0.5 mm apart.

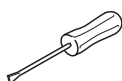
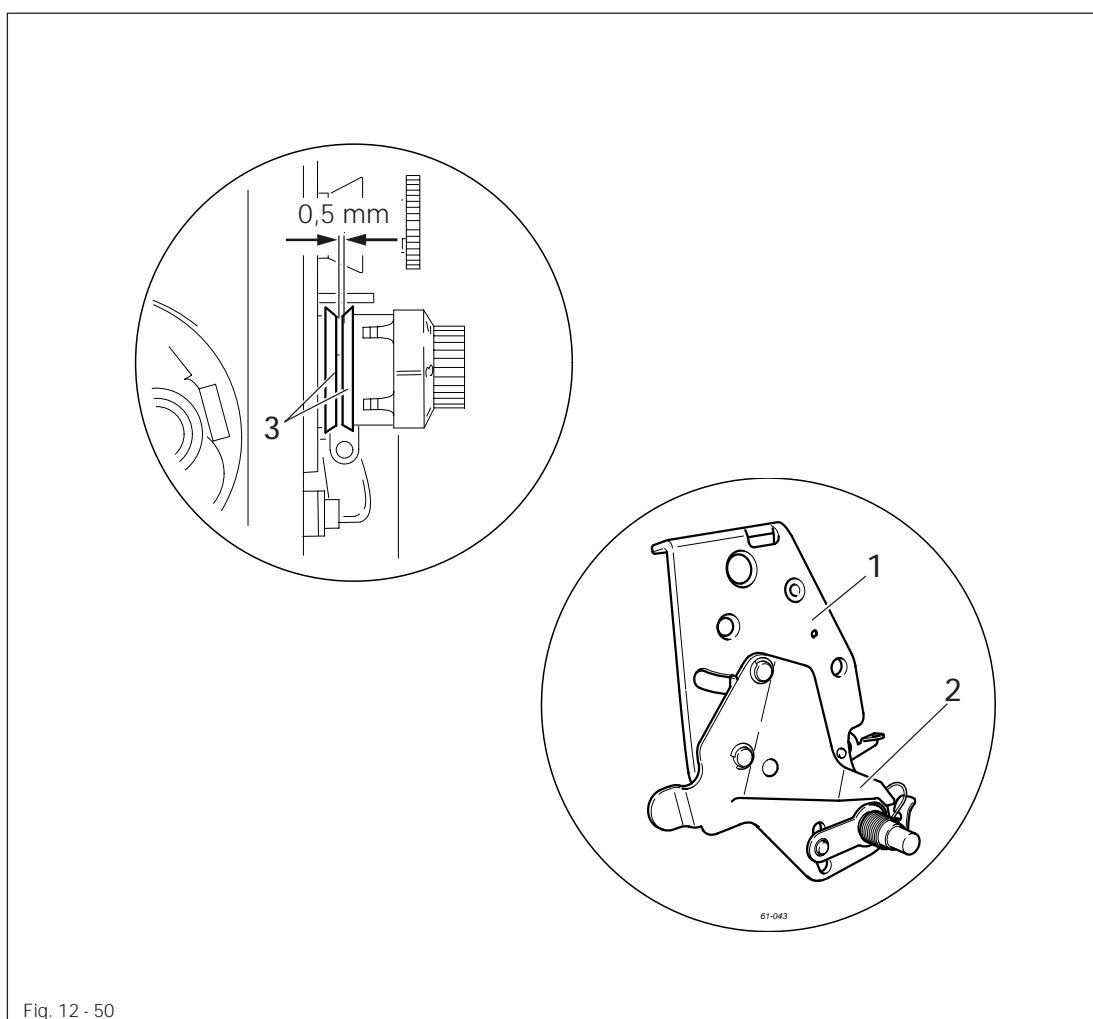

- Activate the magnet.
- Detach the tension bearing plate 1 and adjust pressure plate 2 in accordance with the requirement.



It is possible to set the time for releasing the tension with the parameter functions, see **Chapter 12.09 Parameter settings**.

Adjustment

12.07.09 Linkage rod (only for the PFAFF 574)

Requirement

When the thread trimmer is in its resting position, the drive levers 1 must be parallel.

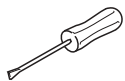
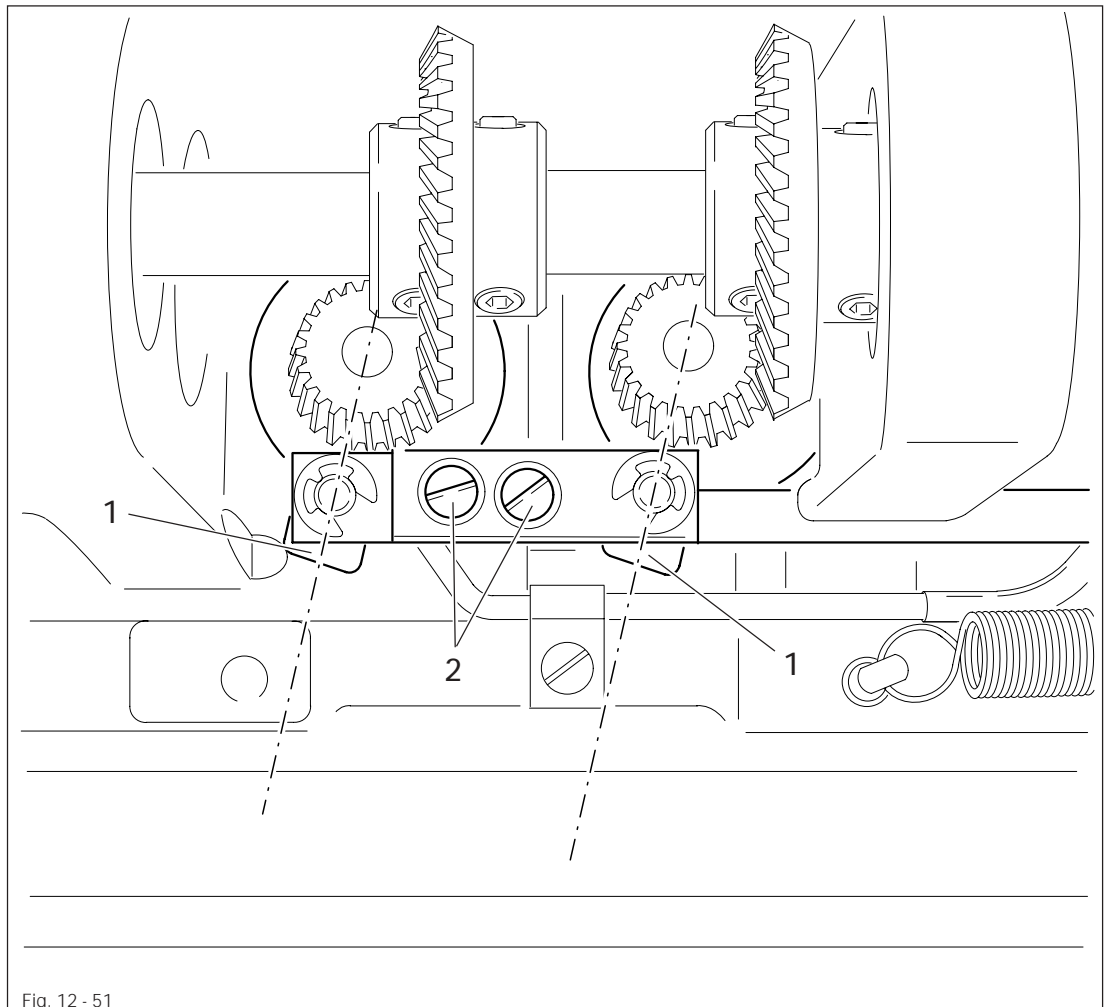

- Adjust drive levers 1 (screws 2) in accordance with the requirement.

12.08 Adjustment of backtacking mechanism -911/..

12.08.01 Needle in needle hole (only for PFAFF 571 and 591)

Requirement

When the maximum stitch length is set, the needle must be the same distance from the inside edge of the needle hole, both for forward and reverse stitch.

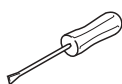
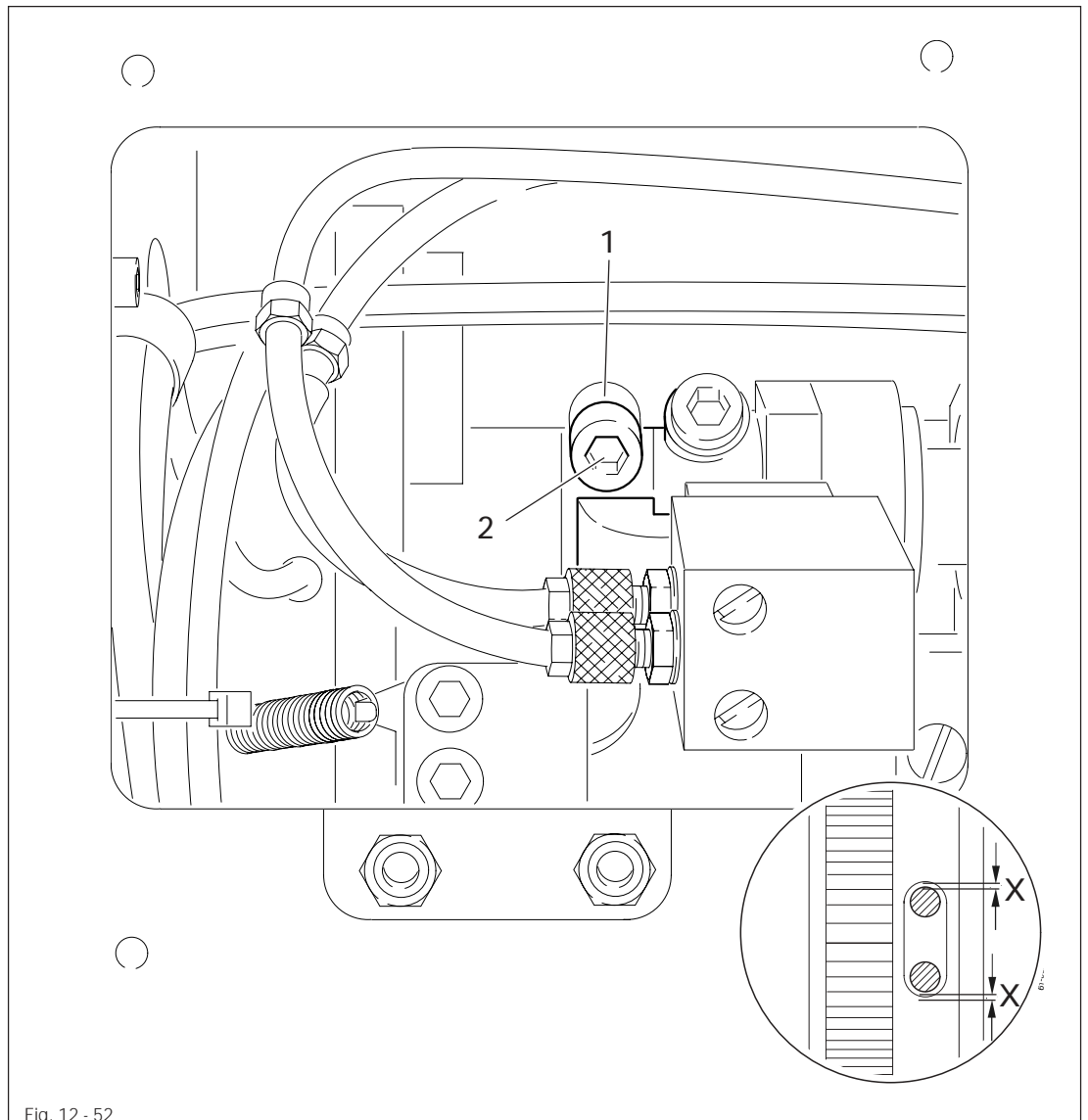

- Turn crank 1 (screws 2) according to the requirement.

Adjustment

12.08.02 Coupling for roller presser drive

Requirement

There must be a distance of **3 mm** between coupling half 1 and locking disc 3 of the drive mechanism.

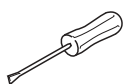
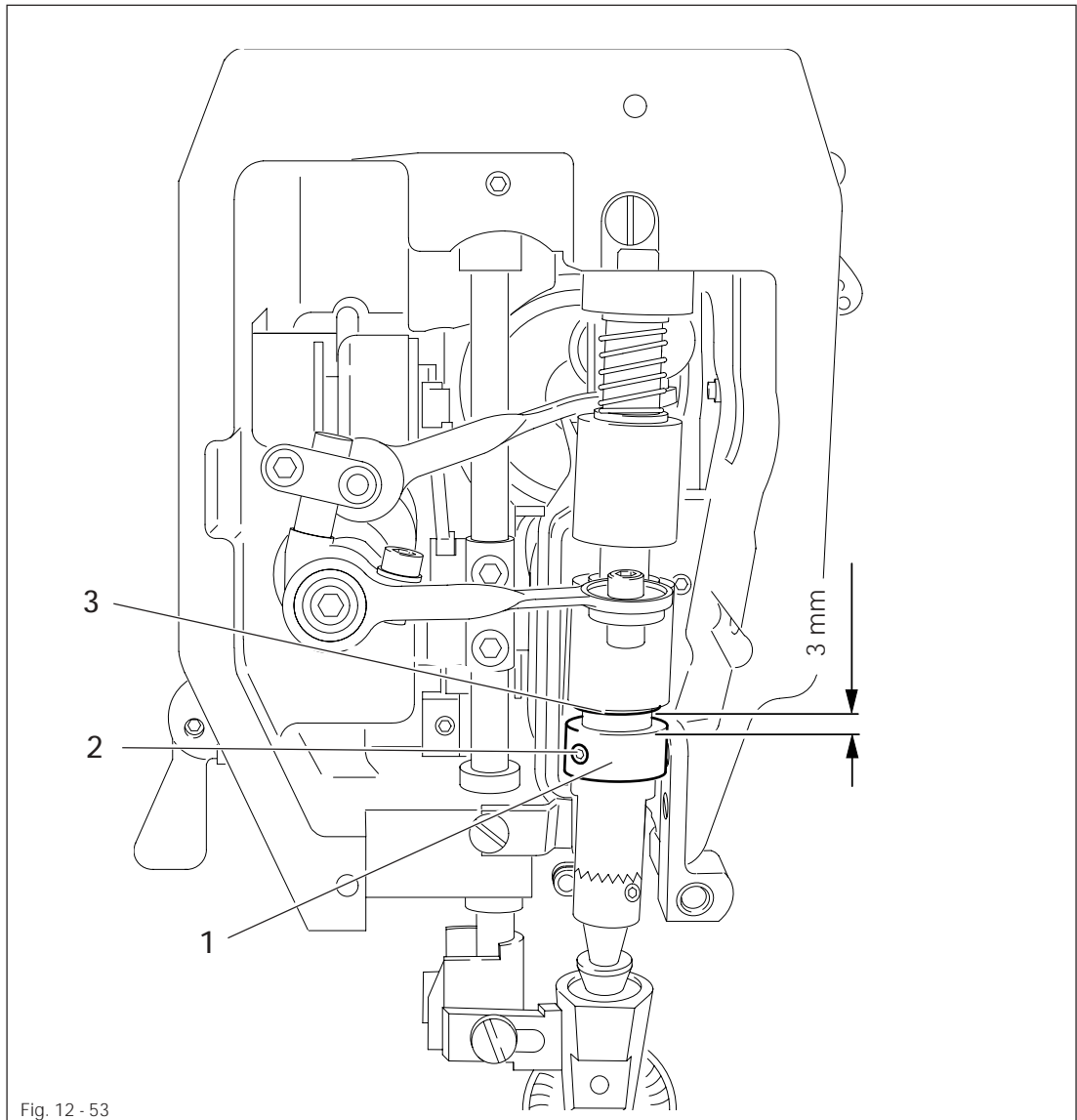

- Adjust coupling half 1 (screw 2) according to the requirement.

12.08.03 Bevel gears for feed wheel drive (on the PFAFF 571 and 574)

Requirements

1. Bevel gear 3 must fit well on the left side.
2. There must be a distance of **14 mm** between bevel gear 3 and bevel gear 5.

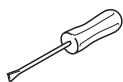
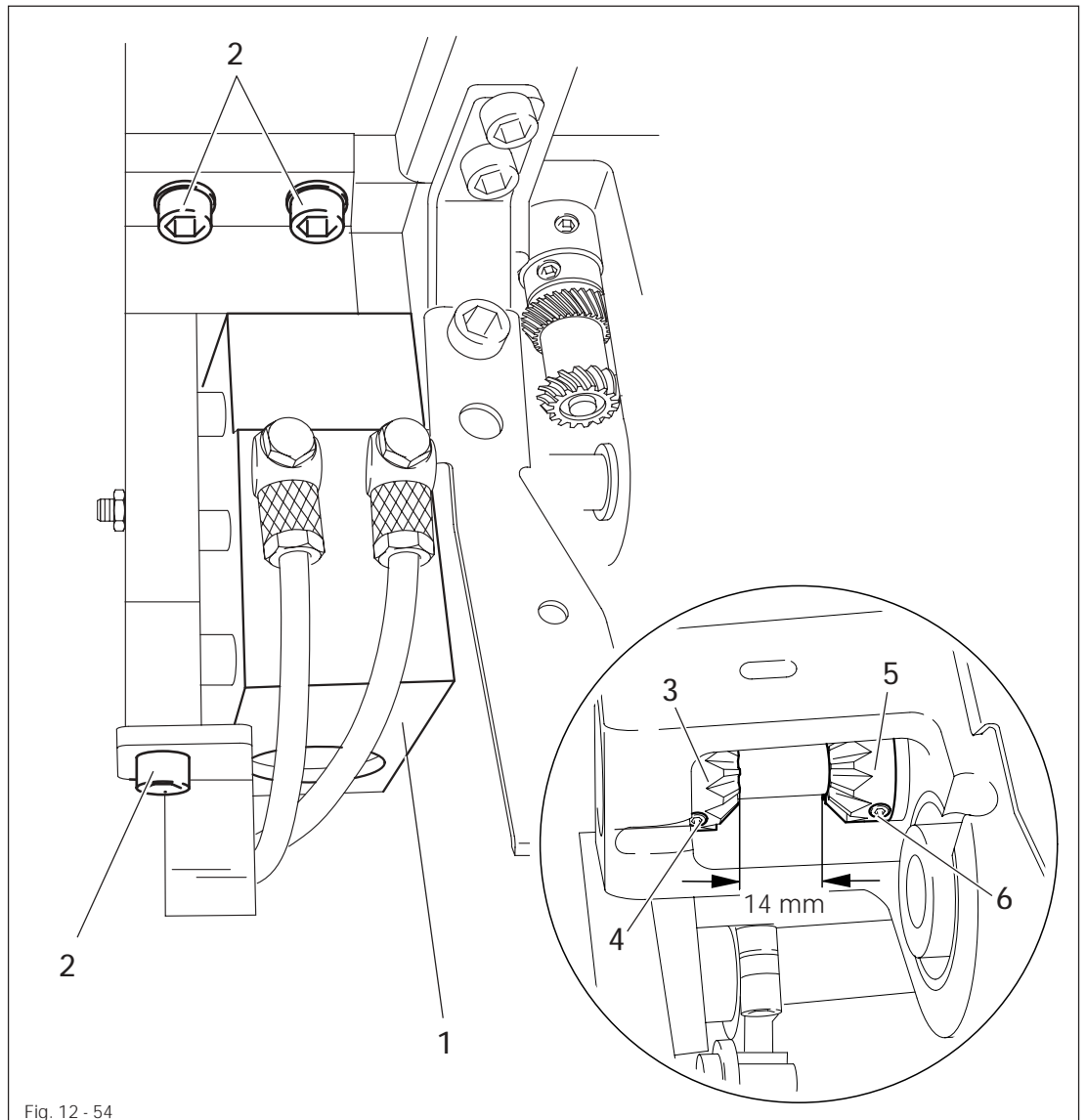

- Remove control unit 1 (screws 2).
- Adjust bevel gear 3 (screws 4) according to requirement 1.
- Adjust bevel gear 5 (screws 6) according to requirement 2.

12.08.04 Bevel gear play (on the PFAFF 571 and 574)

Requirements

1. When sewing forwards, there must be a slight play between bevel gears 6 and 7.
2. When sewing backwards, there must be a slight play between bevel gears 6 and 8.

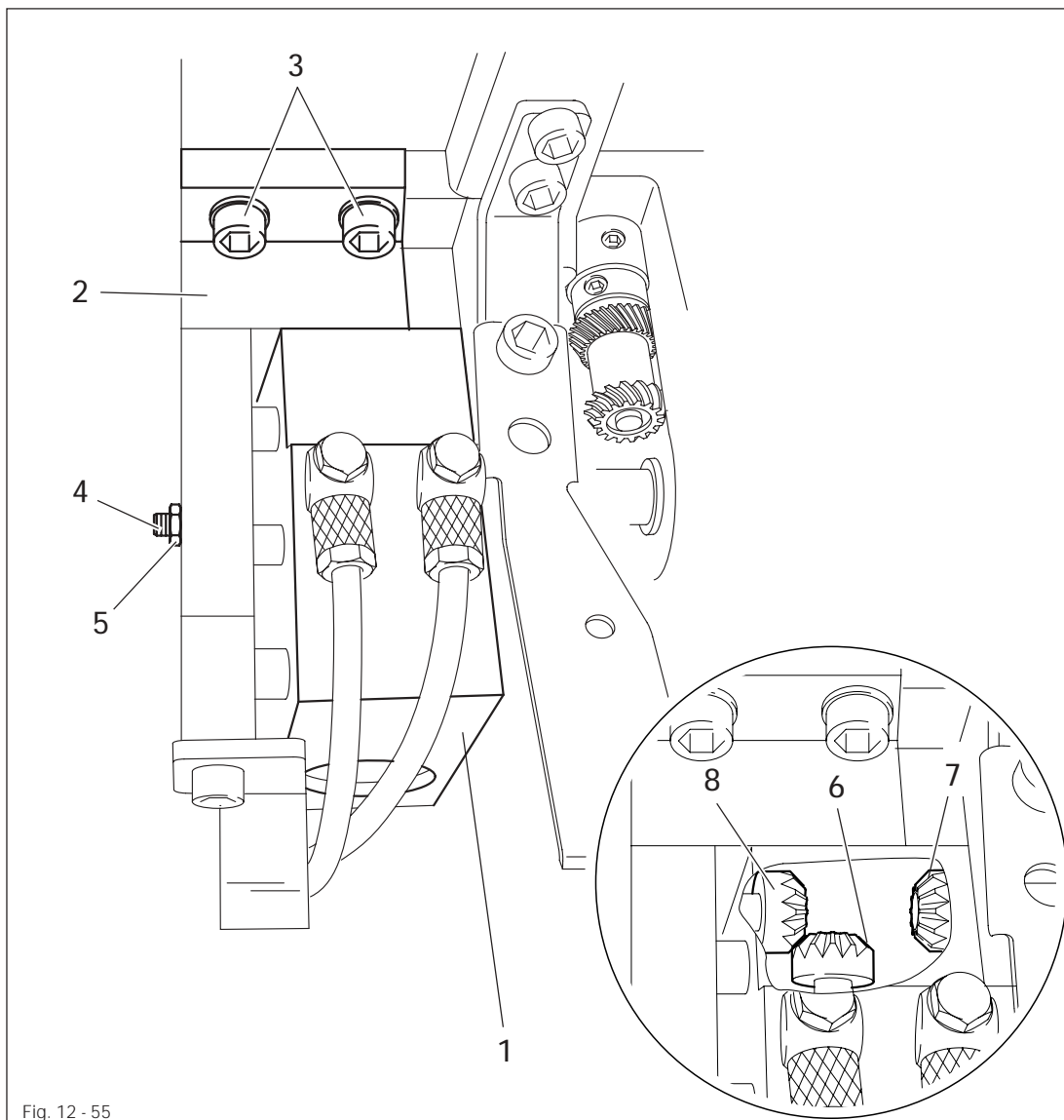
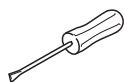

Fig. 12 - 55



- Disconnect air supply of the air filter/lubricator.
- Move unit 1 by hand as far as possible to the right.
- Adjust bracket 2 (screws 3) according to requirement 1.
- Move unit 1 by hand as far as possible to the left.
- Adjust screw 4 (nut 5) according to requirement 2.

12.08.05 KBevel gears for feed wheel drive (on the PFAFF 591)

Requirements

1. The right side of bevel gear 1 must be flush with its drive shaft (see arrow).
2. There must be a distance of 13 mm between bevel gear 3 and bevel gear 1.

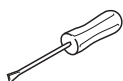
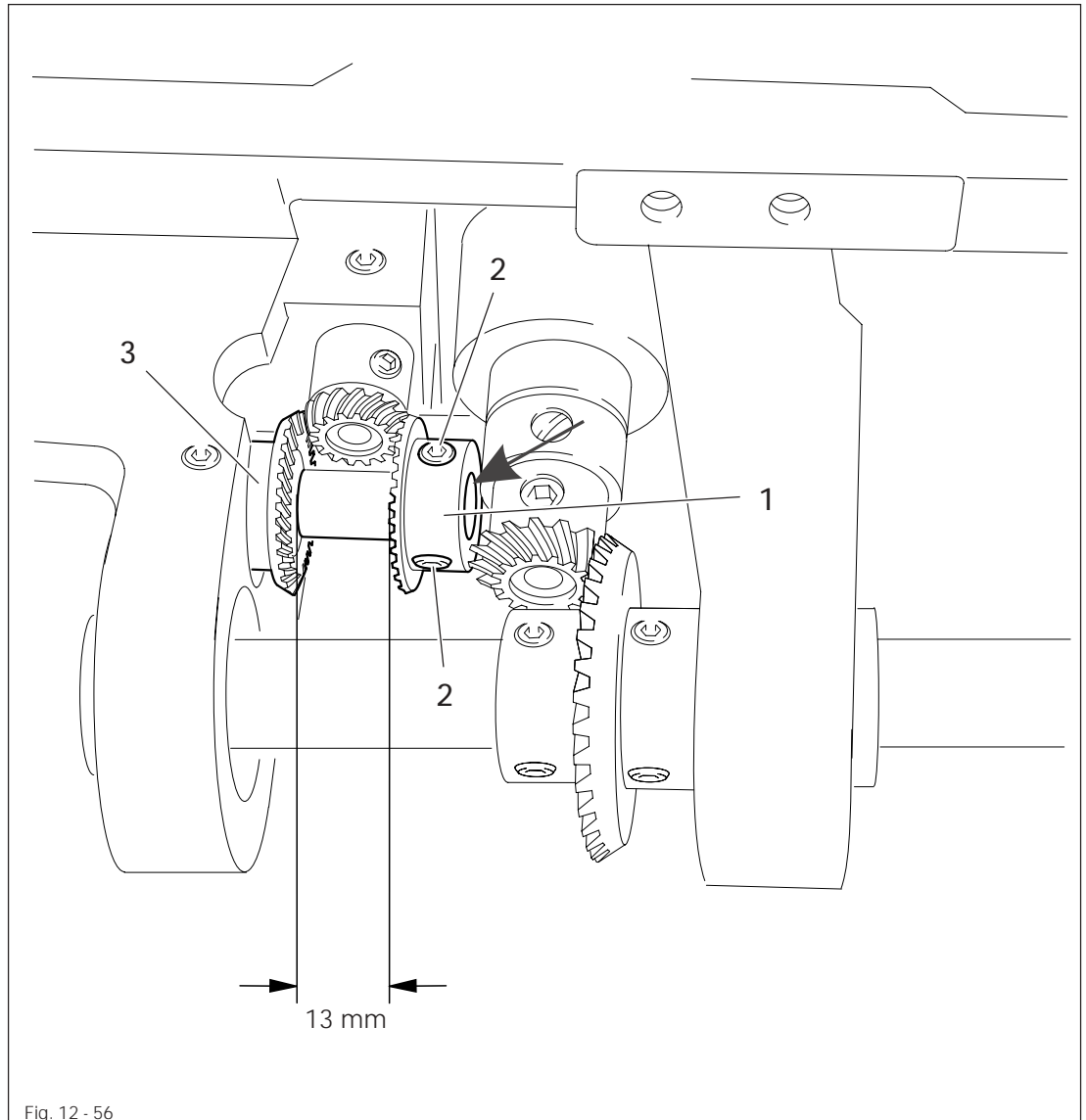

- Adjust bevel gear 1 (screws 2) according to requirement 1.
- Adjust bevel gear 3 (screws 4) according to requirement 2.

12.08.06 Bevel gear play (on the PFAFF 591)

Requirements

1. When sewing forwards, there must be a slight play between bevel gears 6 and 7.
2. When sewing backwards, there must be a slight play between bevel gears 6 and 8.

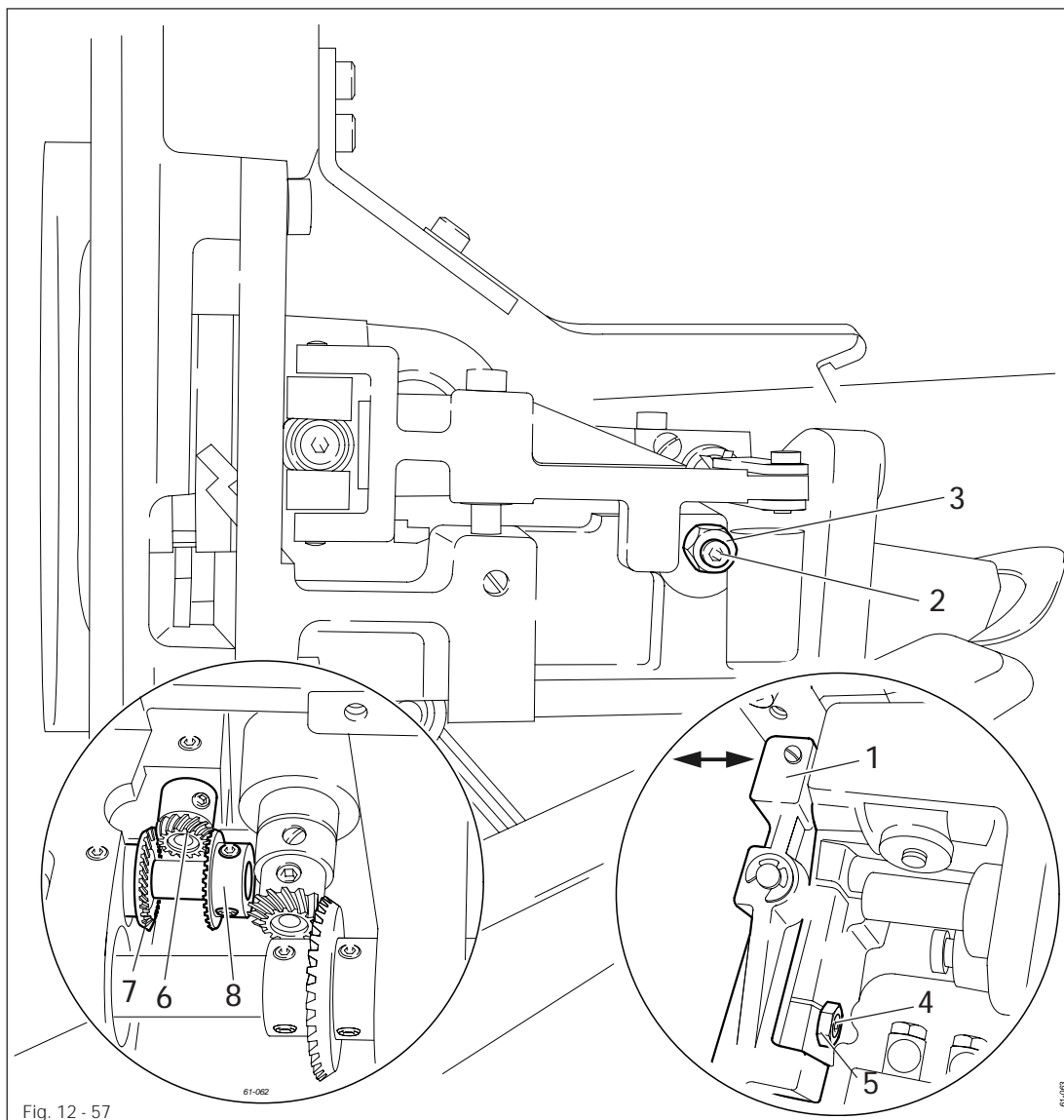

- Disconnect air supply of the air filter/lubricator.
- Move unit 1 by hand as far as possible to the right (see arrow).
- Adjust screw 2 (nut 3) according to requirement 1.
- Move unit 1 by hand as far as possible to the left (see arrow).
- Adjust screw 4 (nut 5) according to requirement 2.

12.09 Parameter settings

12.09.01 Selecting the user level

- Switch on the machine.

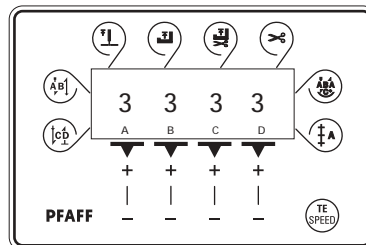

2 x 

- Press the TE/Speed key twice to call up the input mode.

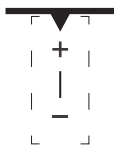
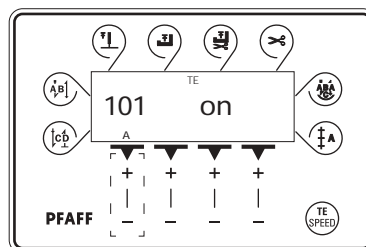

- By pressing the corresponding +/- key select the parameter group "798".

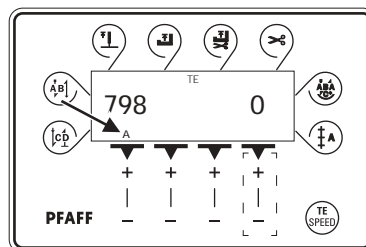

- By pressing the corresponding +/- key select the desired user level:

- "0" = operator level A
- "1" = technician level B
- "11" = service level C

The selected user level is displayed on the screen. (see arrow)

Adjustment

12.09.02 Example of a parameter input

- Switch on the machine.
- Press the **TE/Speed** key twice to select the input mode.

2 x 

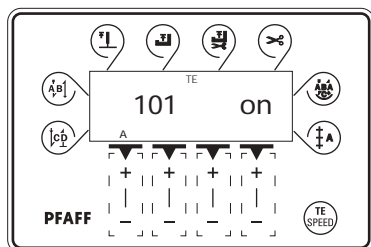

- By pressing the corresponding plus/minus key select parameter "798" and the desired user level, see Chapter 12.09.01 Selecting the user level.

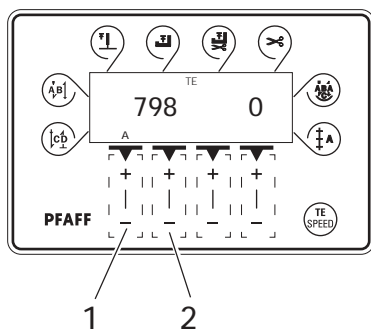

- Select parameter "760" by pressing the +/- keys 1 and 2.

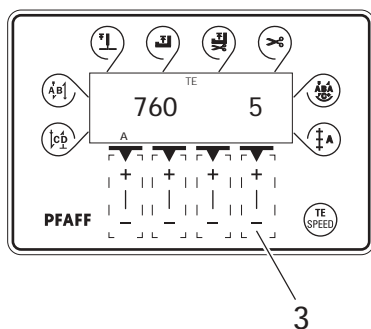



- Select the required value for the total number of stitches (x200) for each bobbin by pressing the +/- key 3.
- By pressing the **TE/Speed** key the selected value is taken over and the machine switches to the sewing mode.

12.09.03 List of parameters

Group	Parameter	Description	User level	Setting range	Set value
1	101	Control panel beep tone (OFF = AUS, ON = EIN)	A,B,C	0 – 1	ON
5	523	Bartacks I = ornamental bartack, II – standard bartack	A,B,C	I – II	I
6	605	Speed display (OFF = AUS, ON = EIN)	B,C	I – II	OFF
	607	Speed	B,C	300 – 3200	3000
	609	Cutting speed 1	B,C	60 – 300	180
	660	Bobbin thread control 0 = off 1 = thread monitor 2 = reverse counter	A,B,C	0 – 2	0
7	700	Needle position 0 (needle reference position)	B,C	0 – 255	0
	702	Needle position 1 (needle lowered)	B,C	0 – 255	80
	703	Needle position 2 (take-up lever raised)	B,C	0 – 255	230
	705	Needle position 5 (end of cutting signal 1)	B,C	0 – 255	200
	706	Needle position 6 (start of cutting signal 2)	B,C	0 – 255	80
	707	Needle position 9 (start thread tension release)	B,C	0 – 255	190
	760	Multiplier for the fixed value (200) for stitch count	A,B,C	0 – 250	5
	798	User level 0 = User level 1 = Technician level 11 = Service level	A,B,C	0,1,11	0
	799	Selected machine class	C	1 – 4	2



Further parameters are listed in the Motor Instruction Manual.

12.09.04 Reset / Cold start

After selecting the reset menu, by pressing the corresponding key it is possible to delete seam parameters, delete seam programs and to carry out a cold start.

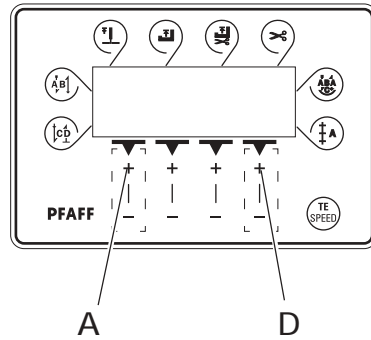

- Press and hold "+" on keys A and D and switch on the machine, see Chapter 7.01 Main switch.

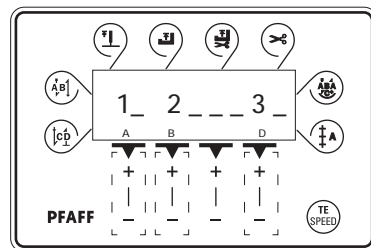

Resetting the seam parameters

- Press "+" on key "A".

All parameters are deleted, the display "—rE—" appears for a short time on the screen.



Resetting the seam programs

- Press "+" on key "B".

All seam programs are deleted, the display "—rE—nA" appears for a short time on the screen.



Cold start

- Press "+" on key "D".

With the exception of the value for the machine class, the values of the machine control unit are set back to their basic values, the display "—COLd—" appears for a short time on the screen.



After the cold start all programmed values are set back to their status at the time of delivery. For this reason after a cold start it is necessary to re-enter first the parameter "799" and then the parameter "700".

12.10 Internet update of the machine software

The machine software can be updated with PFAFF flash programming. For this purpose the PFP boot program and the appropriate control software for the machine type must be installed on a PC. To transfer the data to the machine, the PC and the machine control unit must be connected with an appropriate null modem cable (part no. 91-291 998-91).



The PFP boot program and the control software of the machine type can be downloaded from the PFAFF-homepage using the following path:
www.pfaff-industrial.com/de/service/download/steuerungssoftware.html

To update the machine software carry out the following steps:



While the machine software is being updated, no setting up, maintenance or adjustment work may be carried out on the machine!

- Switch off the machine.
- Connect the PC (serial interface or appropriate USB-adapter) and the machine control unit (RS232).
- Switch on the PC and start the PFP boot program.
- Select the machine type.
- Press the "programming" button.
- An extra program (quick loader) is started.
- Switch on the machine within 60 seconds.
- The software update is carried out, the update progress is shown on the bar display.
- When the update has been completed, the message "**software update successfully completed**" appears.



If this message does not appear, the entire procedure must be repeated!
The machine is not safe for operation until the programming has been completed successfully and without faults.

- Switch off the machine and end the quick loader and PFP boot program.
- End the connection between the PC and the machine control unit.
- Switch on the machine.
- A plausibility control is carried out and, if necessary, a cold start.



More information and assistance is at your disposal in the file "PFPHILFE.TXT", which can be called up from the PFP boot program by pressing the "help" button.

12.11 Explanation of the error signals

Signal	Description
E001	Pedal not in neutral position
E009	Start inhibitor during standstill
E010	Incorrect machine class
E062	Short circuit 24V
E063	Overload mains supply circuit
E064	Network monitoring
E065	Extint low in operation
E066	Short circuit
E067	Network off
E068	Extint low in operation
E069	No increments
E070	Motor blocking
E071	No incremental connector
E074	External transmitter for synchronisation marker missing
E088	RAM defective
E092	Start inhibitor when motor running
E173	Start error
E175	Start error

13.01 Wearing parts



This list indicates the most important wearing parts.

You can request a detailed parts list for the complete machine under parts number 296-12-18 757.

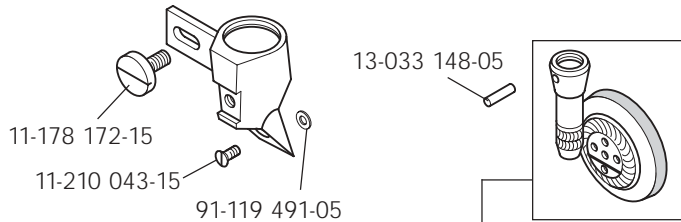

- 91-119 942-93/001 (Roller presser, with 35 mm dia., 4.0 mm wide, toothed)
- 91-175 109-90 (Roller presser, with 35 mm dia., 2.6 mm wide, smooth)
- 91-263 108-91 (Roller presser, with 35 mm dia., 4.0 mm wide, coated with plastic-material)
- 91-175 776-93/001 (Roller presser, with 25 mm dia., 4.0 mm wide, toothed)
- 91-119 478-93/001 (Roller presser, with 25 mm dia., 2.6 mm wide, toothed)
- 91-175 108-90 (Roller presser, with 25 mm dia., 2.6 mm wide, smooth)



PFAFF 571, 574, 591

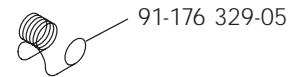

91-176 329-05

PFAFF 574

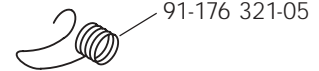

91-176 321-05

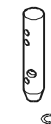

11-108 093-15

91-173 664-15

91-263 400-91 (A; B)
91-263 405-91 (C)

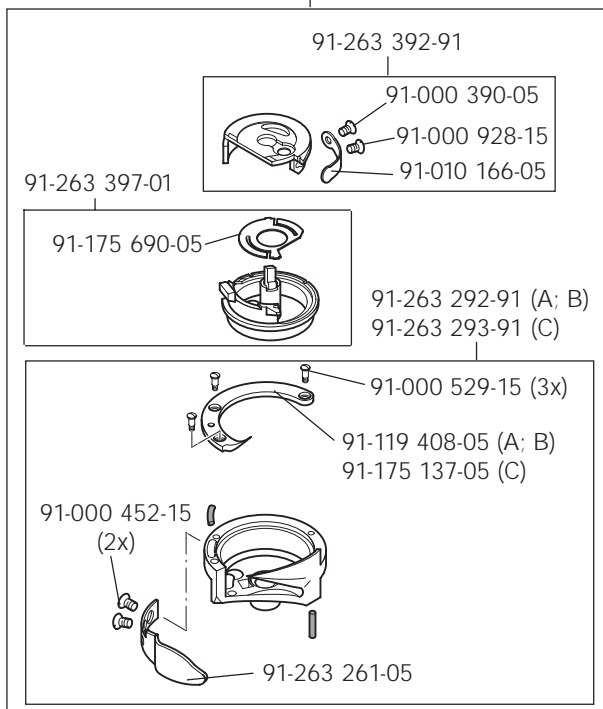

91-118 308-05

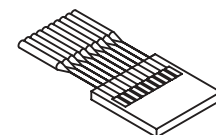
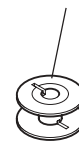

PFAFF 571, 591
System 134

PFAFF 574
System 134-35

Wearing parts

For sub-class -900/81

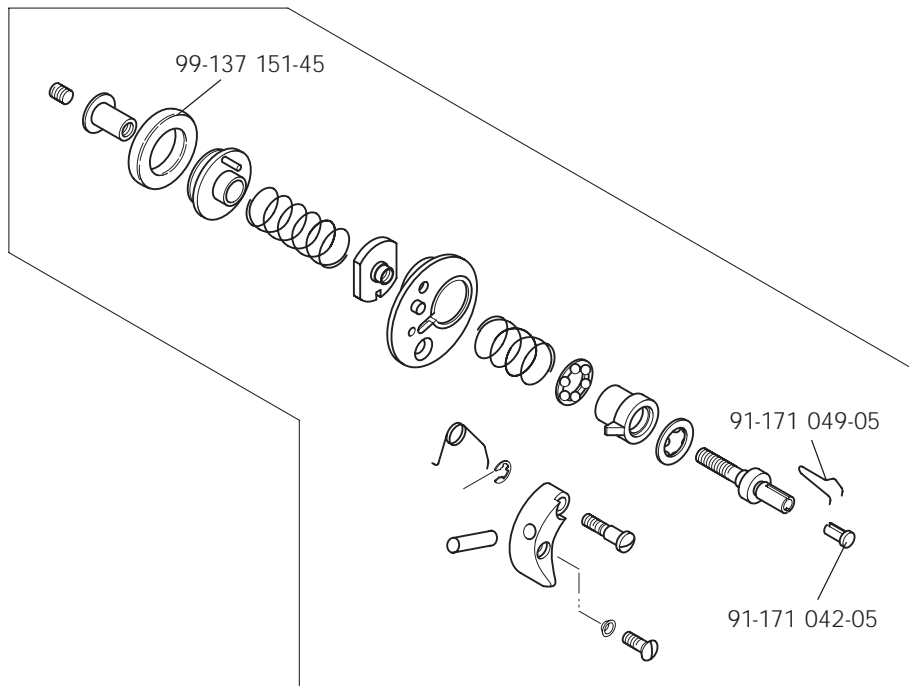
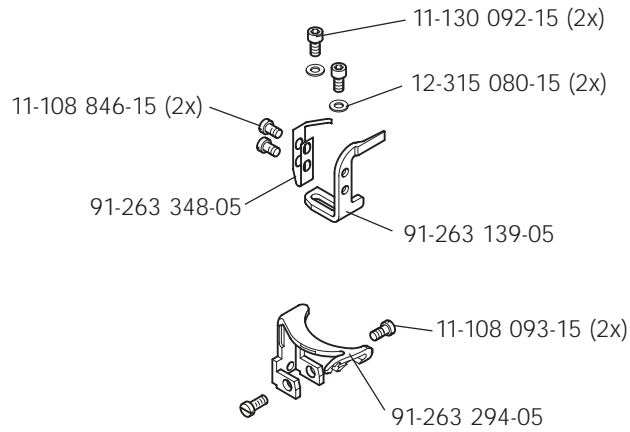

571-725/04

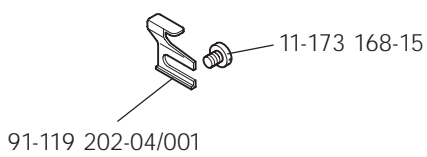

574-725/04; 591-725/04

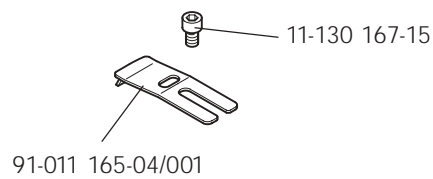

591-726/05

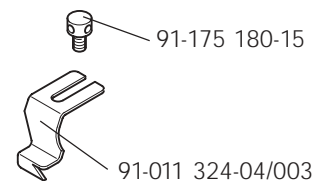

14 Circuit diagrams**Reference list for circuit diagrams**

A1	Controller (Quick P40 ED)
A2	Control panel S1
A14	Sewing head identification (OTE)
C1	Start capacitor knife motor
H1	Sewing lamp
H10	LED Stitch counter
K1	Relay knife motor
M1	Sewing motor
M10	Knife motor
Q1	Main switch
S1	Pedal set value transmitter
S10	Knife motor key
S41	Manual backtacking key
S42	Needle position change key
S43	Single stitch key
S46	Start inhibitor key
T10	Transformer knife motor
X0	RS232 – interface (PC)
X1	Motor
X2	Incremental transmitter
X3	Set value transmitter
X4	Control panel
X5	Inputs/outputs
X6	Bobbin thread monitor (optional)
X7	Light barrier (optional)
X22	Thread trimmer (-900/..)
X24	Automatic presser foot lift (-910/..)
X25	Connector for backtacking device (-911/..)
X28	Thread tension solenoid
X40	Keyboard
X46	Start inhibitor
X50	Sewing head identification (OTE)
Y2	Thread trimmer (- 900/..)
Y4	Automatic presser foot lift (-910/..)
Y2	Backtacking device (-911/..)
Y8	Thread tension solenoid

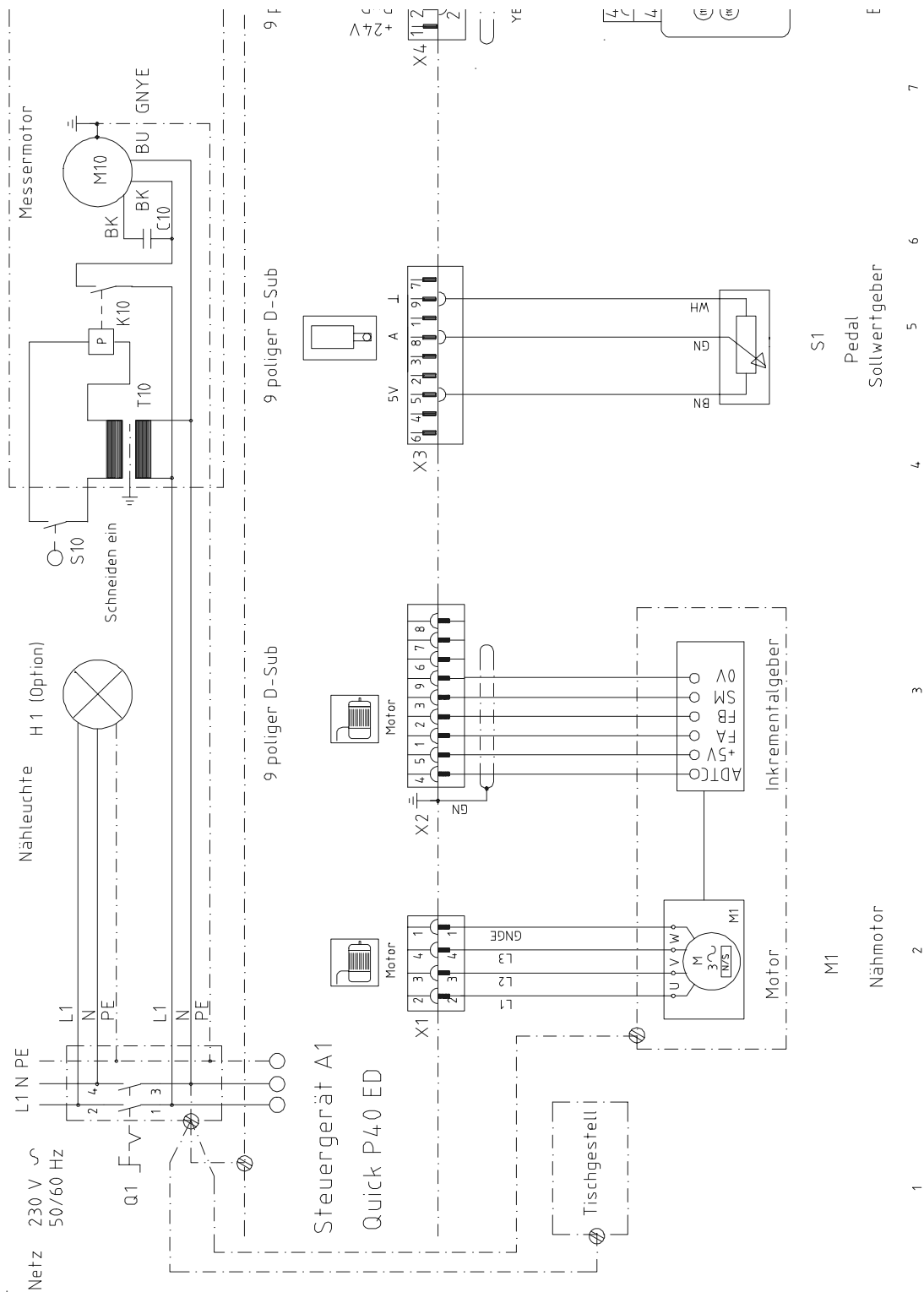

Steuergerät A1
Quick P40 ED

Ausgänge und Eingänge
37 poliger D-Sub

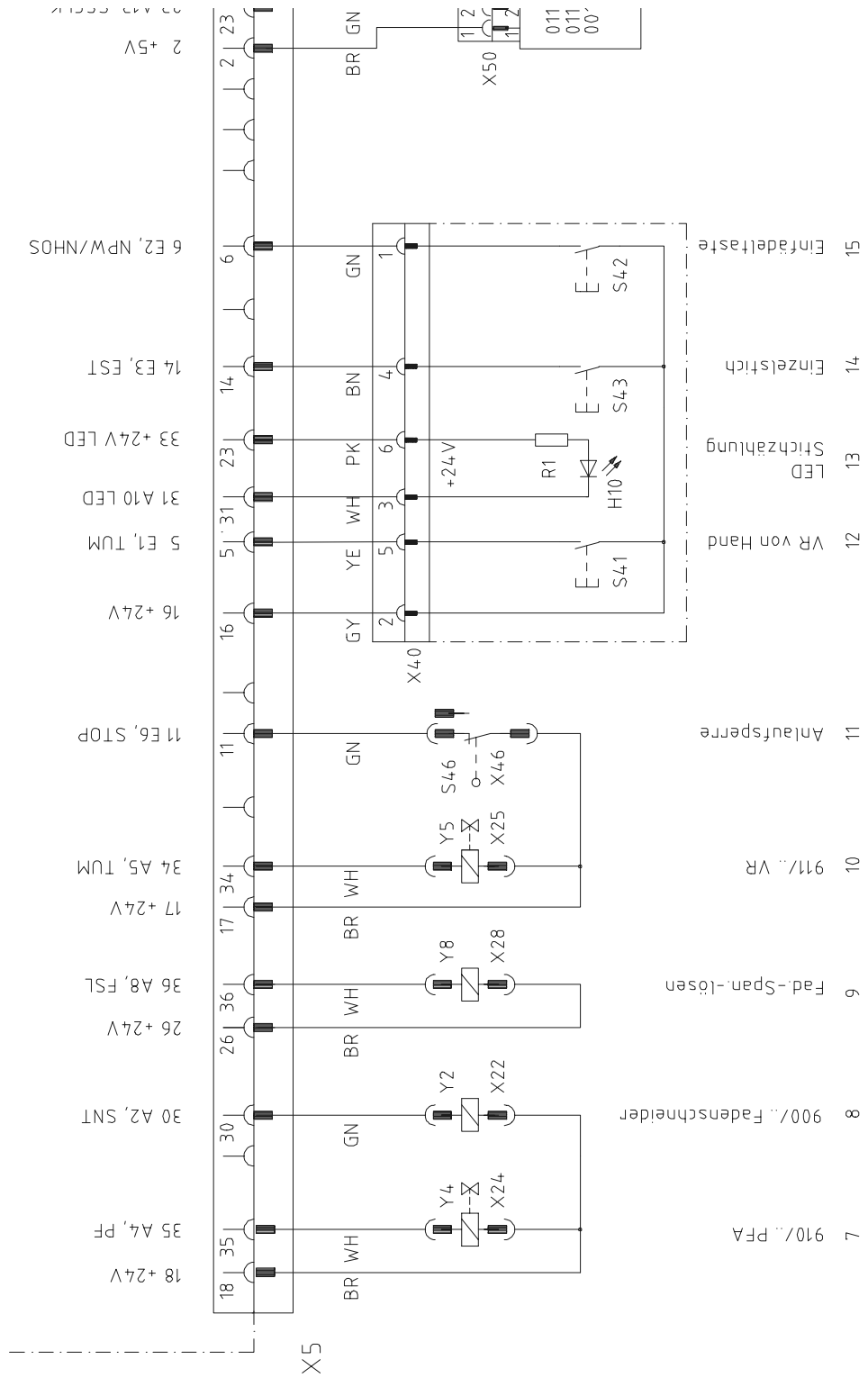

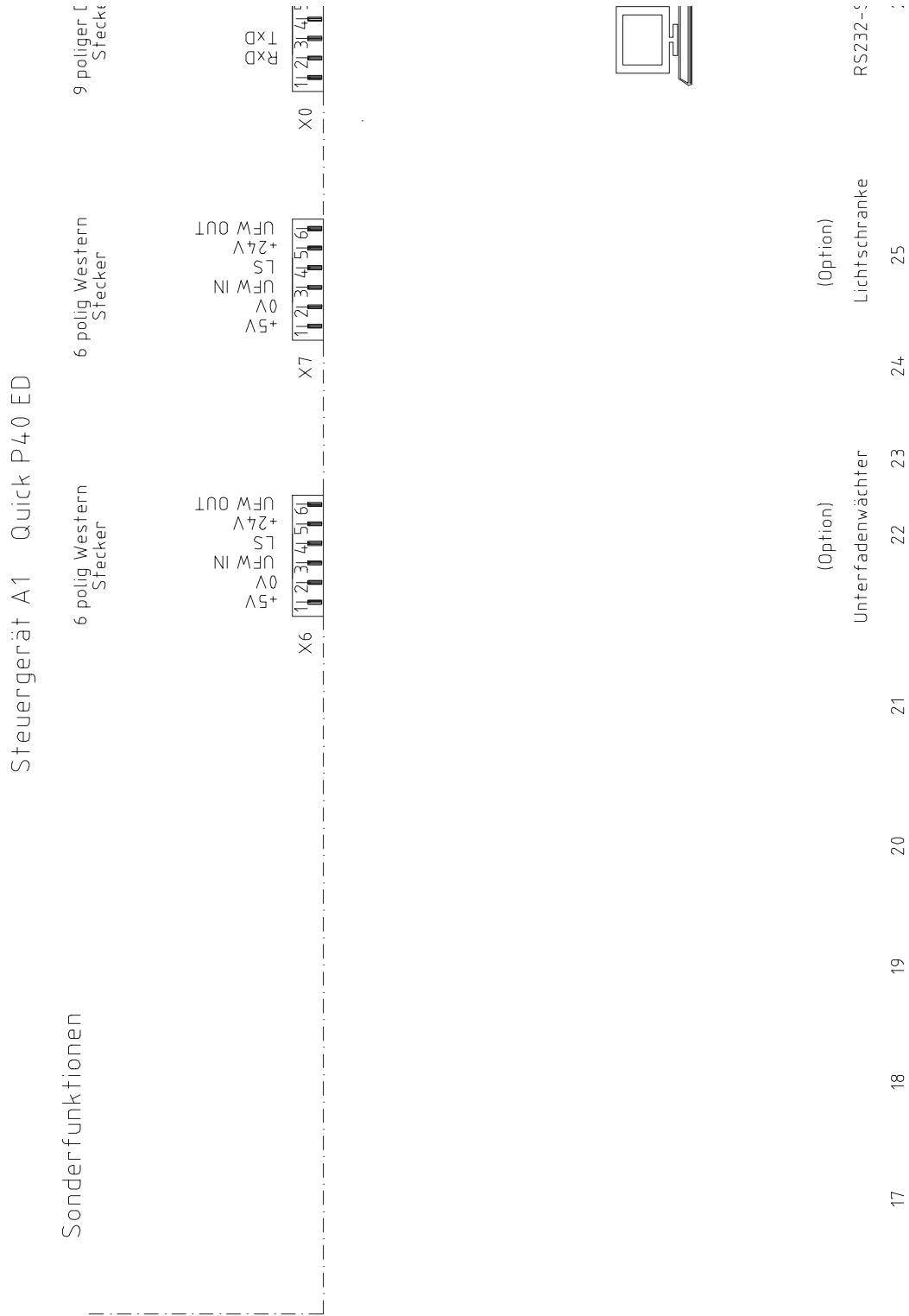

PFAFF

PFAFF Industrie Maschinen AG

Postfach 3020
D-67653 Kaiserslautern

Königstr. 154
D-67655 Kaiserslautern

Telefon: (0631) 200-0
Telefax: (0631) 17202
E-Mail: info@pfaff-industrial.com

Gedruckt in der BRD
Printed in Germany
Imprimé en R.F.A.
Impreso en la R.F.A.