

PFAFF

1425

1426

Instruction Manual

This instruction manual applies to machines from the following serial numbers onwards:

PFAFF 1425 # 2572934 →
PFAFF 1426 # 2572935 →



This instruction manual applies to all versions and subclasses listed under "**Specifications**".

Reprinting, copying or translation of PFAFF instruction manuals, whether in whole or in part, is not permitted without our prior permission and not without written indication of the source.

**G.M. PFAFF KAISERSLAUTERN
INDUSTRIEMASCHINEN AG**

Postfach 3020
D-67653 Kaiserslautern

Königstr. 154
D-67655 Kaiserslautern

Editing/illustrations
HAAS-Publikationen GmbH
D-53840 Troisdorf

Contents		Chapter - Page
1	Safety	1 - 1
1.01	Regulations	1 - 1
1.02	General notes on safety	1 - 1
1.03	Safety symbols	1 - 2
1.04	Important notes for the user	1 - 2
1.05	Notes for operating and technical staff	1 - 3
1.05.01	Operating staff	1 - 3
1.05.02	Technical staff	1 - 3
1.06	Danger warnings	1 - 4
2	Proper use	2 - 1
3	Specifications	3 - 1
3.01	PFAFF 1425, PFAFF 1426	3 - 1
3.02	Possible work aids	3 - 2
4	Machine disposal	4 - 1
5	Transportation, packing and storage	5 - 1
5.01	Transportation to customer's premises	5 - 1
5.02	Transportation inside customer's premises	5 - 1
5.03	Disposal of packing materials	5 - 1
5.04	Storage	5 - 1
6	Explanation of symbols	6 - 1
7	Controls	7 - 1
7.01	On/off switch	7 - 1
7.02	Keys on machine head	7 - 1
7.03	Pedal	7 - 2
7.04	Knee switch	7 - 2
7.05	Presser foot fixing key	7 - 3
7.06	Stich-length setting	7 - 3
7.07	Reverse-feed control	7 - 4
7.08	Edge trimmer -731/02	7 - 4
7.09	Secondary needle-thread tension	7 - 5
7.10	Setting quick-change stepping control -918/29	7 - 5
7.11	Bobbin-thread supply monitor -926/06	7 - 6
7.12	Bobbin thread control by stitch counting -926/07	7 - 6
8	Installation and commissioning	8 - 1
8.01	Installation	8 - 1
8.01.01	Adjusting the table height	8 - 1
8.01.02	Fitting the tilt lock	8 - 2
8.01.03	Tensioning the v-belt	8 - 2
8.01.04	Fitting the upper v-belt guard	8 - 3
8.01.05	Fitting the bottom v-belt guard	8 - 3
8.01.06	Fitting the synchroniser	8 - 4

	Contents	Chapter - Page
8.01.07	Fitting the reel stand	8 - 4
8.01.08	Connecting the earth cables	8 - 5
8.02	Commissioning	8 - 6
8.03	Switching the machine on/off	8 - 6
9	Setting up	9 - 1
9.01	Inserting the needle on the PFAFF 1425	9 - 1
9.02	Inserting the needles on the PFAFF 1426	9 - 2
9.03	Winding the bobbin thread, regulating the winder tension	9 - 3
9.04	Bobbin-changing/threading, and regulating the bobbin thread tension	9 - 4
9.05	Threading needle thread and regulating its tension on the PFAFF 1425	9 - 5
9.06	Threading needle threads and regulating tensions on the PFAFF 1426	9 - 6
10	Care and maintenance	10 - 1
10.01	Cleaning the hook area	10 - 1
10.02	Oiling the hook	10 - 2
10.03	Checking/adjusting the air pressure	10 - 3
10.04	Cleaning the air filter of the air-filter/lubricator	10 - 3
11	Adjustment	11 - 1
11.01	Tools, gauges and other equipment	11 - 1
11.02	Notes on adjustment	11 - 1
11.03	Abbreviations	11 - 1
11.04	Adjusting the basic machine	11 - 2
11.04.01	Adjusting the synchronizer	11 - 2
11.04.02	Balance weight	11 - 3
11.04.03	Neutral position of the unison feed	11 - 4
11.04.04	Feeding motion of the unison feed	11 - 5
11.04.05	Lifting motion of the bottom feed dog	11 - 6
11.04.06	Bottom feed-dog height	11 - 8
11.04.07	Needle in needle-hole centre	11 - 9
11.04.08	Feeding-stroke difference	11 - 10
11.04.09	Needle height (preliminary adjustment)	11 - 11
11.04.10	Needle rise, hook clearance, needle height (final adjustment) and needle guard	11 - 12
11.04.11	Bobbin-case opener stroke	11 - 14
11.04.12	Top feed stroke	11 - 15
11.04.13	Top feed lifting motion	11 - 16
11.04.14	Clearance between lifting presser and needle plate	11 - 17
11.04.15	Bobbin winder	11 - 18
11.04.16	Thread check spring and thread regulator on the PFAFF 1425	11 - 19
11.04.17	Thread check springs and thread regulator on the PFAFF 1426	11 - 20
11.04.18	Speed reduction when the stroke is increased	11 - 21
11.04.19	Needle-thread tension release	11 - 22
11.04.20	Lubrication	11 - 23
11.04.21	Re-engaging the slip-clutch	11 - 24

Contents		Chapter - Page
11.05	Adjusting the edge trimmer -731/02	11 - 25
11.05.01	Neutral position of knife	11 - 25
11.05.02	Knife stroke	11 - 26
11.05.03	Cutting stroke	11 - 27
11.05.04	Actuating lever	11 - 28
11.05.05	Knife height	11 - 29
11.05.06	Knife position in sewing direction	11 - 30
11.05.07	Knife position crosswise to sewing direction	11 - 31
11.06	Adjusting the thread trimmer -900/81	11 - 32
11.06.01	Resting position of roller lever / radial position of control cam	11 - 32
11.06.02	Thread catcher height	11 - 33
11.06.03	Thread catcher position	11 - 34
11.06.04	Knife height	11 - 35
11.06.05	Knife pressure	11 - 36
11.06.06	Bobbin-thread retaining spring	11 - 37
11.06.07	Thread-catcher transmission crank (only on PFAFF 1426)	11 - 38
11.06.08	Transmission linkage (only on PFAFF 1426)	11 - 39
11.06.09	Manual cutting test	11 - 40
11.07	Adjusting the thread trimmer -900/82	11 - 41
11.07.01	Resting position of the roller lever/Preliminary adjustment of the radial position of the control cam	11 - 41
11.07.02	Thread catcher and knife height	11 - 42
11.07.03	Knife mounting support	11 - 43
11.07.04	Knife cutting position	11 - 44
11.07.05	Thread catcher position	11 - 45
11.07.06	Readjustment of the control cam	11 - 46
11.07.07	Knife pressure	11 - 47
11.07.08	Bobbin-thread retaining spring	11 - 48
11.07.09	Manual cutting test	11 - 49
11.08	Adjusting the bobbin-thread supply monitor -926/06	11 - 50
11.09	Parameter settings	11 - 51
11.09.01	Selecting and changing parameters	11 - 51
11.09.02	List of parameters	11 - 52
12	Wearing parts	12 - 1

1 Safety

1.01 Regulations

This machine is constructed in accordance with the European regulations indicated in the conformity and manufacturer's declarations.

In addition to this instruction manual, please also observe all generally accepted, statutory and other legal requirements, including those of the user's country, and the applicable pollution control regulations!

The valid regulations of the regional social insurance society for occupational accidents or other supervisory authorities are to be strictly adhered to!

1.02 General notes on safety

- The machine must only be operated by adequately trained operators and only when the instruction manual has been fully read and understood!
- All notices on safety and the instruction manual of the motor manufacturer are to be read before the machine is put into operation!
- All notes on the machine concerning danger and safety must be observed!
- The machine must be used for the purpose for which it is intended and must not be operated without its safety devices; all regulations relevant to safety must be adhered to.
- When part sets are changed (e.g. needle, presser foot, needle plate, feed dog or bobbin), during threading, when the workplace is left unattended and during maintenance work, the machine must be isolated from the power supply by turning off the on/off switch or removing the plug from the mains!
- Daily maintenance work must only be carried out by appropriately trained persons!
- Repairs and special maintenance work must only be carried out by qualified technical staff or persons with appropriate training!
- During maintenance or repairs on the pneumatic system the machine must be isolated from the compressed air supply! The only exception to this is when adjustments or function checks are carried out by appropriately trained technical staff!
- Work on the electrical equipment must only be carried out by technical staff who are qualified to do so!
- Work on parts or equipment connected to the power supply is not permitted! The only exceptions to this are specified in regulations EN 50110.
- Conversion or modification of the machine must only be carried out under observation of all relevant safety regulations!

- Only spare parts which have been approved by us are to be used for repairs! We draw special attention to the fact that spare parts and accessories not supplied by us have not been subjected to testing nor approval by us. Fitting and/or use of any such parts may cause negative changes to the design characteristics of the machine. We shall not accept any liability for damage caused by the use of non-original parts.

1.03 Safety symbols



Danger!
Special points to observe.



Danger of injury to operating or technical staff!



Caution

Do not operate without finger guard and safety devices. Before threading, changing bobbin and needle, cleaning etc. switch off main switch.

1.04 Important notes for the user

- This instruction manual belongs to the equipment of the machine and must be available to the operating staff at all times.
This instruction manual must be read before the machine is operated for the first time.
- Both operating and technical staff must be instructed on the safety devices of the machine and on safe working methods.
- It is the duty of the user to operate the machine in perfect running order only.
- The user must ensure that none of the safety devices are removed nor put out of working order.
- The user must ensure that only authorized persons operate and work on the machine.

For further information please refer to your PFAFF agency.

1.05 Notes for operating and technical staff

1.05.01 Operating staff

Operating staff are the persons responsible for setting up, operating and cleaning the machine and for removing any disturbances in the sewing area.

The operating staff are obliged to observe the following points, and must:

- always observe the notes on safety in this instruction manual!
- avoid using any working methods which adversely effect the safety of the machine!
- avoid wearing loose-fitting clothing or jewelry such as necklaces or rings!
- also ensure that only authorized persons are allowed near the danger area of the machine!
- immediately report to the user any changes to the machine that may affect its safety!

1.05.02 Technical staff

Technical staff are persons who have been trained in electrical engineering, electronics, pneumatics and mechanical engineering. They are responsible for lubricating, servicing, repairing and adjusting the machine.

The technical staff are obliged to observe the following points, and must:

- always observe the notes on safety in this instruction manual!
- switch off the on/off switch before carrying out adjustment and repair work and ensure it cannot be switched on again unintentionally!
- never work on parts or equipment still connected to the power supply! Exceptions to this are only permissible according to regulations EN 50110;
- isolate the machine from the compressed air supply when carrying out maintenance or repair work on pneumatic equipment!
Exceptions to this are only permissible for function checks;
- replace all safety covers after carrying out maintenance or repair work!

1.06 Danger warnings



A working area of 1 m must be kept free both in front of and behind the machine, so that easy access is possible at all times.



Never put your hands in the sewing area during sewing!
Danger of injury by the needle!



While setting or adjusting the machine do not leave any objects on the table nor in the needle plate area! Objects may be trapped or slung out of the machine!

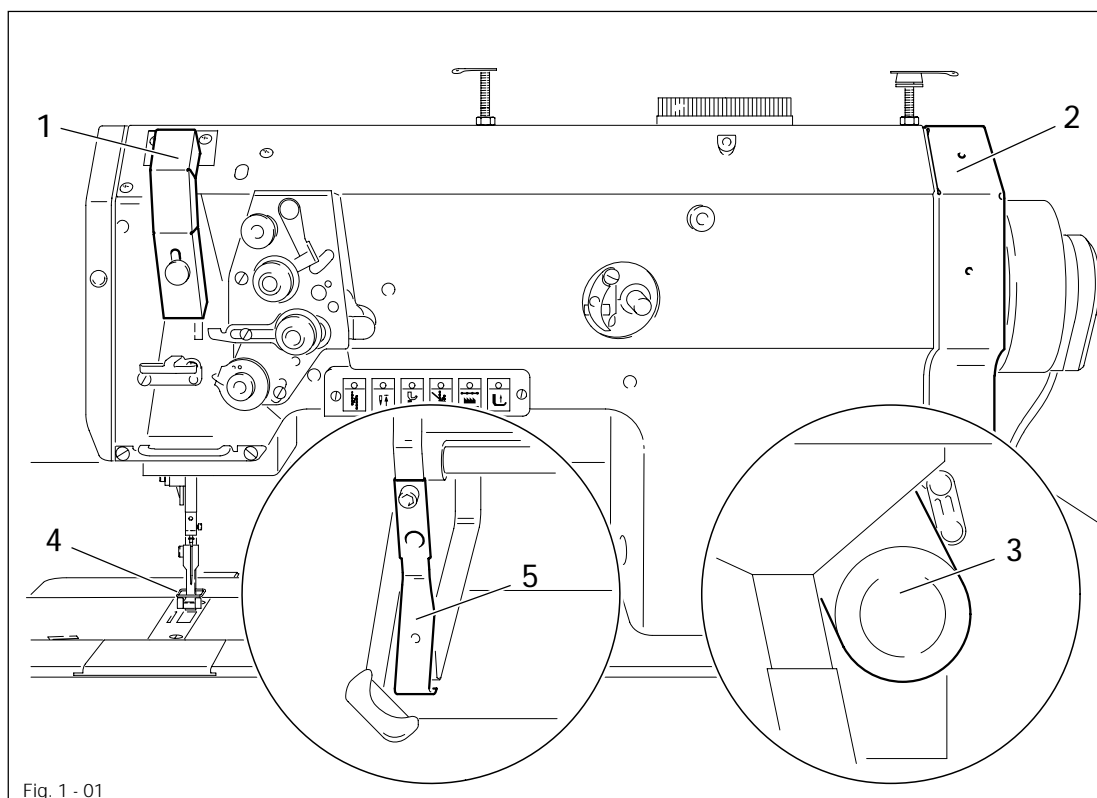

Fig. 1 - 01



Do not operate the machine without take-up lever guard 1!
Danger of injury due to movement of the take-up lever!



Do not operate the machine without belt guards 2 und 3!
Dange of injury by the rotating v-belt!



Do not operate the macine without finger guard 4!
Danger of injury by the needle!



Do not operate the machine without tilt lock 5!
Danger of crushing between sewing head and table!

2

Proper use

The **PFAFF 1425** is a special single-needle high-speed lockstitch seamer with unison feed and large sewing hook.

The **PFAFF 1426** is a special two-needle high-speed lockstitch seamer with unison feed and large sewing hook.

These machines are intended for sewing lockstitch seams in the textile industry.



Any use of these machines which is not approved by the manufacturer shall be considered as improper use! The manufacturer shall not be liable for any damage arising out of improper use! Proper use shall also be considered to include compliance with the operation, adjustment, service and repair measures specified by the manufacturer!

3 Specifications**3.01 PFAFF 1425, PFAFF 1426**

Stitch type: 301 (lockstitch)

Version C N8; C/D N8

Needle sizes

Version C N8 100 to 140

Version C/D N8 150 to 180

Max. thread size.

Version C N8 15/3-ply

Version C/D N8 11/3-ply

(synthetic, or other sizes of comparable thread types)

Effective dia. of balance wheel: 80 mm

Fabric clearance: 18 mm

Clear workspace width: 285 mm

Clear workspace height: 115 mm

Max. stitch length: 8 mm

Workplace noise level at corresponding speeds

(noise measurement according to DIN 45 635-48-A-1, ISO 11204, ISO 3744, ISO 4871)

at a speed of 2800 r.p.m. (2400 s.p.m), PFAFF 1425: ≤ 78 dB (A)

at a speed of 2800 r.p.m. (2400 s.p.m.), PFAFF 1426: ≤ 80 dB (A)

Luftverbrauch pro Schaltzyklus: 0,146 NI

Net weight of sewing head, PFAFF 1425: approx. 50 kg

Net weight of sewing head, PFAFF 1426: approx. 52 kg

Gross weight, PFAFF 1425: approx. 58 kg

Gross weight, PFAFF 1426: approx. 60 kg

Subject to alterations in design, weights and dimensions.

Specifications

Maximum sewing speed

The maximum sewing speed depends on the material to be sewn, and thus on the top feed stroke.

Top feed stroke	PFAFF 1426 Max. sewing speed in s.p.m. at needle gauges:					PFAFF 1425 Max. speed in s.p.m.
	6 mm	12 mm	20 mm	28 mm	40 mm	
1 mm	3800	3600	3400	3200	3000	4000
2 mm	3400	3200	3000	2850	2700	3600
3 mm	3000	2850	2700	2500	2300	3000
4 mm	3000	2500	2300	2150	2000	3000
5 mm	2200	2100	2000	1900	1800	2200
6 mm	1800	1900	1800	1700	1600	1800
7 mm	1800	1700	1600	1500	1400	1800

3.02 Available versions and workaids

Version C N8: for sewing medium-heavy materials

Version C/D N8: for sewing medium-heavy to heavy materials

Work aids:

-731/02 Edge trimmer

-900/81 Thread trimmer

-900/82 Thread trimmer

-910/04 Automatic presser foot lift

-911/35 Backtacking mechanism

-918/29 Quick-change stepping control and stitch-length adjustment

-926/06 Bobbin thread supply monitor

-926/07 Bobbin thread control by stitch counting

4 Disposal of Machine

- Proper disposal of the machine is the responsibility of the customer.
- The materials used for the machine are steel, aluminium, brass and various plastic materials.
The electrical equipment comprises plastic materials and copper.
- The machine is to be disposed of according to the locally valid pollution control regulations; if necessary, a specialist is to be commissioned.



Care must be taken that parts soiled with lubricants are disposed of separately according to the locally valid pollution control regulations!

5 Transportation, packing and storage

5.01 Transportation to customer's premises

Within the Federal Republic of Germany, complete machines (with table and motor) are delivered without packing.

Machines without table (only sewing heads) and machines intended for exports are packed.

5.02 Transportation inside the customer's premises

The manufacturer cannot be made liable for transportation inside the customer's premises nor to other operating locations. It must be ensured that the machines are only transported in an upright position.

5.03 Disposal of packing materials

The packing materials of this machine comprise paper, cardboard and VCE fibre. Proper disposal of the packing material is the responsibility of the customer.

5.04 Storage

If the machine is not in use, it can be stored as it is for a period of up to six months, but It should be protected against dust and moisture.

If the machine is stored for longer periods, the individual parts, especially the surfaces of moving parts, must be protected against corrosion, e.g. by a film of oil.

6 Explanation of symbols

In this instruction manual, work to be carried out or important information is accentuated by symbols. These symbols have the following meanings:



Note, information



Cleaning, care



Lubrication

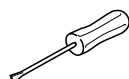

Maintenance, repairs, adjustment, service work
(only to be carried out by technical staff)

7 Controls

7.01 On/off switch

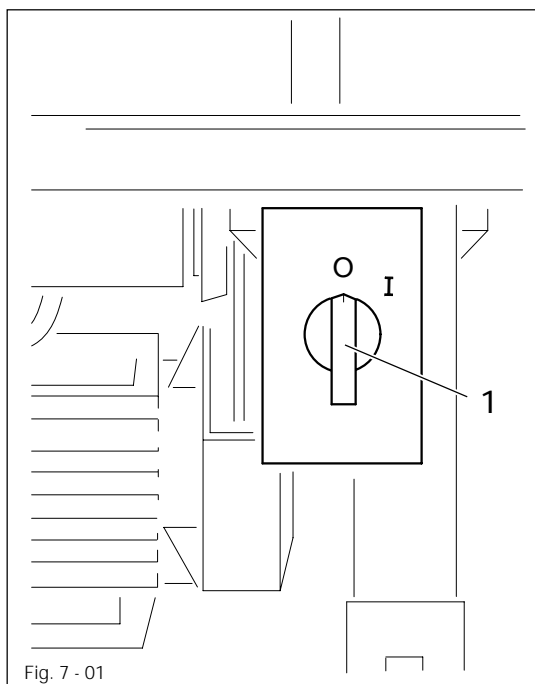

Fig. 7 - 01

- Switch machine on or off by turning on/off switch 1.

7.02 Keys on machine head

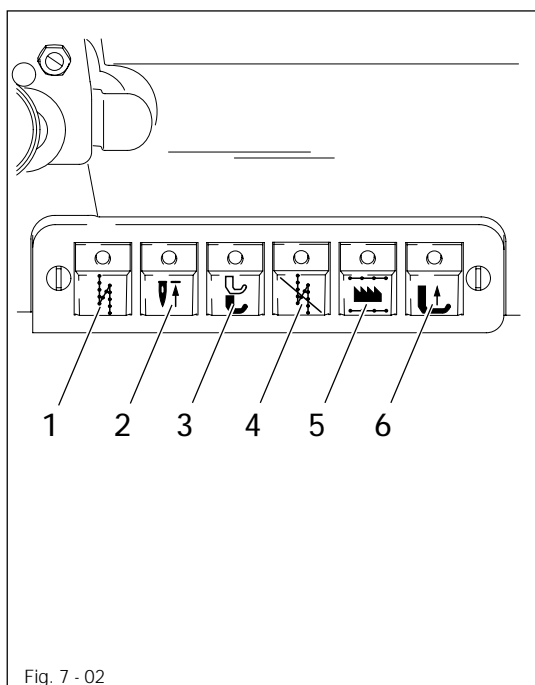

Fig. 7 - 02

- The keys on the machine head are pressed to set off certain functions.

Key 1: Reverse sewing or intermediate backtack within the seam

Key 2: Raise needle

Key 3: Activate pre-set top-feed stroke (on machines with quick-change stepping control) -918/29)
 Diode on = high stroke
 Diode off = low stroke

Key 4: Switch off backtack function for one tack

Key 5: Activate pre-set stitch length (on machines with quick-change stepping control -918/29)
 Diode on = long stitch length
 Diode off = short stitch length

Key 6: EMERGENCY key. presser foot and needle are raised and the machine switched off (diode on).

7.03 Pedal

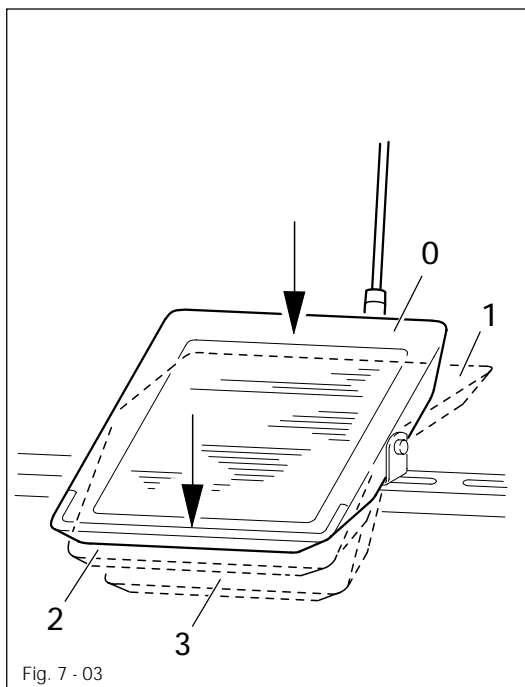

- 0 = Neutral position
- 1 = Sewing
- 2 = Raise presser foot
- 3 = Trim sewing threads



For other pedal functions please refer to the instruction manual of the motor manufacturer.

7.04 Knee switch

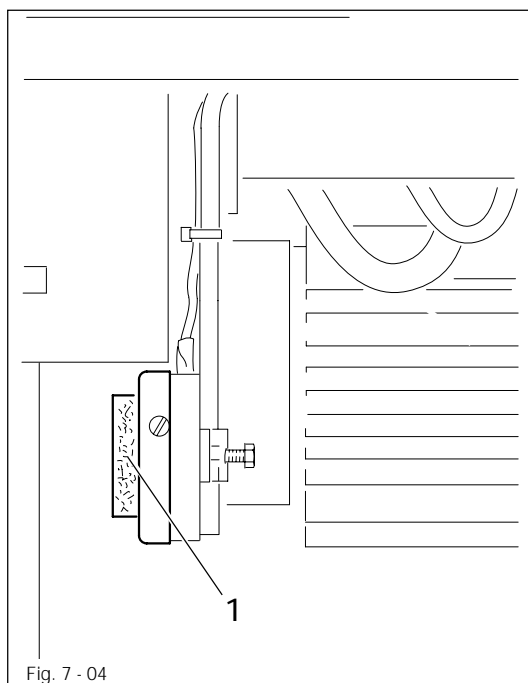

- By operating knee switch 1 it is possible to alternate between two pre-selected feed stroke settings.



For the high stroke setting the speed is reduced. The function of the knee switch can be changed; please refer to the instruction manual of the motor manufacturer.

7.05 Presser foot fixing key

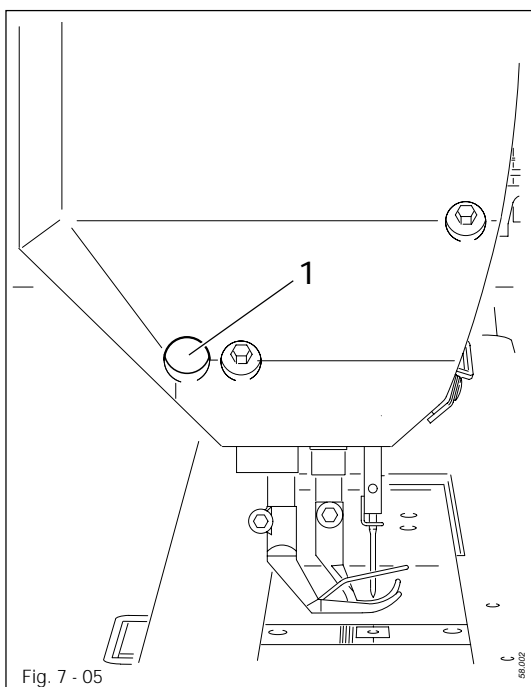

- To fix the presser foot, raise it with the pedal, then press key 1 and release the pedal again.
- To release the presser foot, raise it briefly with the pedal.

7.06 Adjusting the stitch length

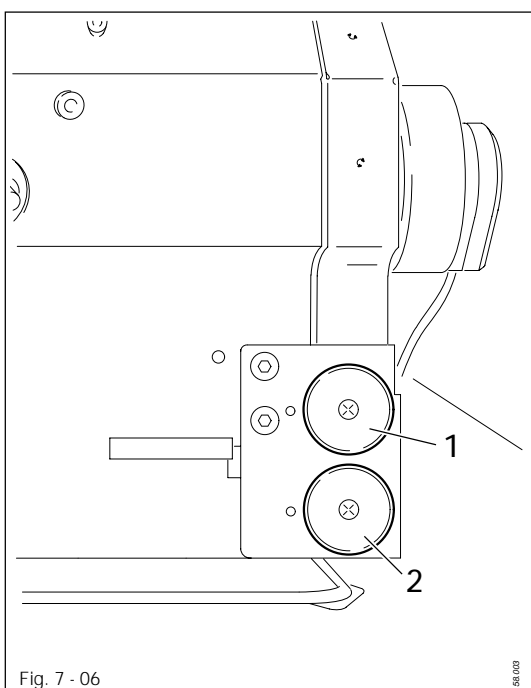

- The thumb wheels 1 and 2 can be used to pre-select the stitch lengths.
- The adjustment is made by pressing and at the same time turning the thumb wheels.
- The maximum stitch length is set with thumb wheel 1 and the minimum stitch length with thumb wheel 2.
- The pre-selected stitch lengths can be called up with key 5, see Chapter 7.02 Keys on the machine head.

7.07 Reverse-feed control

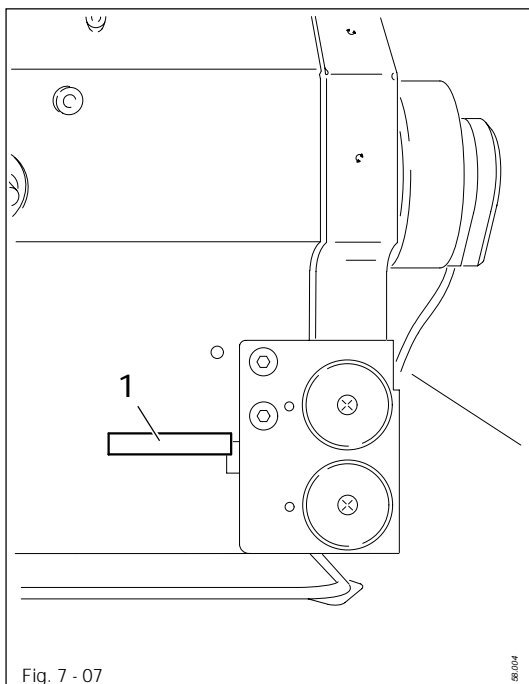

- To sew in reverse, press reverse-feed control lever 1.

7.08 Edge trimmer -731/02

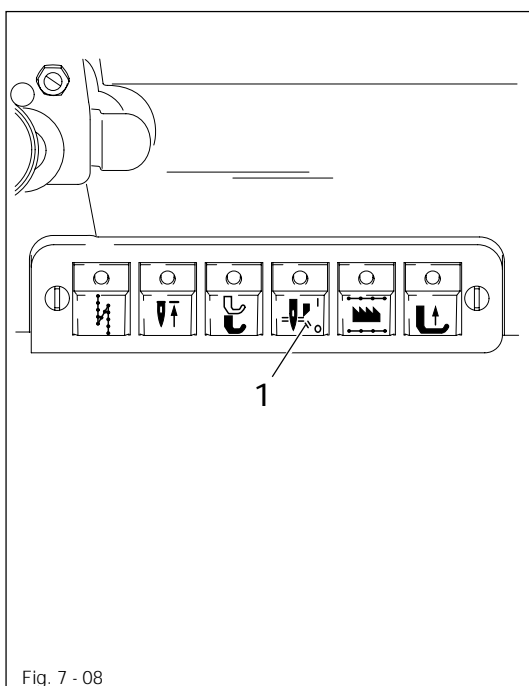

Keep your hands away from the moving knife! Danger of injury!

- Press key 1 to switch the knife drive on or off.



The bartack suppression key is omitted, see Chapter 7.02 Keys on the machine head.

7.09 Secondary needle-thread tension

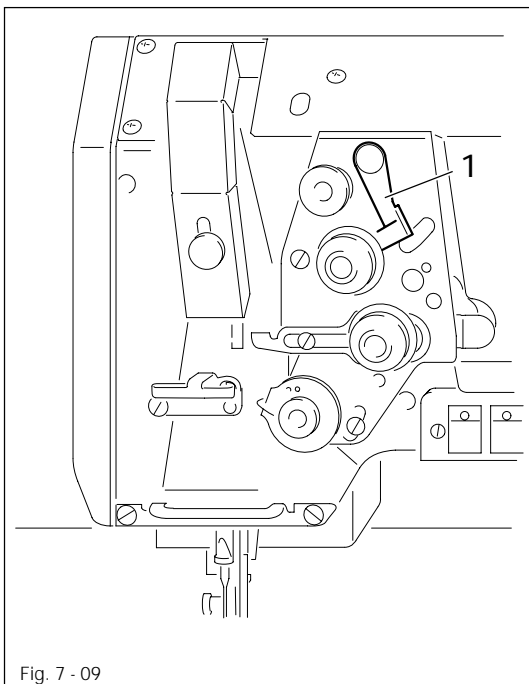

- To increase the needle-thread tension dis-engage lever 1 by pushing it to the right.

7.10 Adjusting the top feed stroke

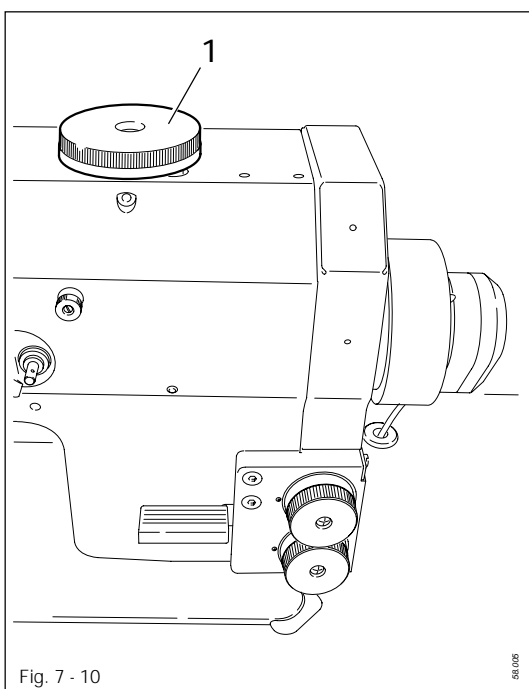

- The top feed stroke can be adjusted by turning knob 1.



The maximum top feed stroke is limited by the manufacturer. The limit can be changed by technical staff, see **Chapter 11.04.12 Top feed stroke**.

7.11 Bobbin thread supply monitor -926/06

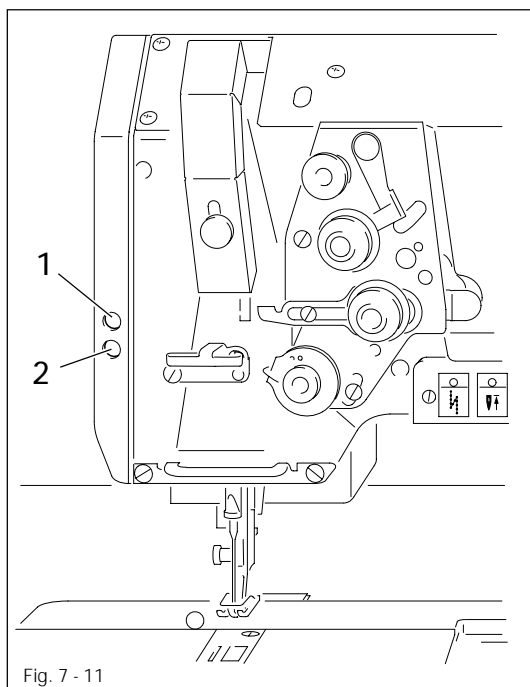

PFAFF 1425

- When the set thread-end length is reached, diode 1 flashes and the machine is stopped.

PFAFF 1426

- When the set thread end-length is reached, diode 1 (left bobbin) or 2 (right bobbin) flashes.

To finish sewing the seam, release the pedal and press it forwards again.

7.12 Bobbin thread control by stitch counting -926/07

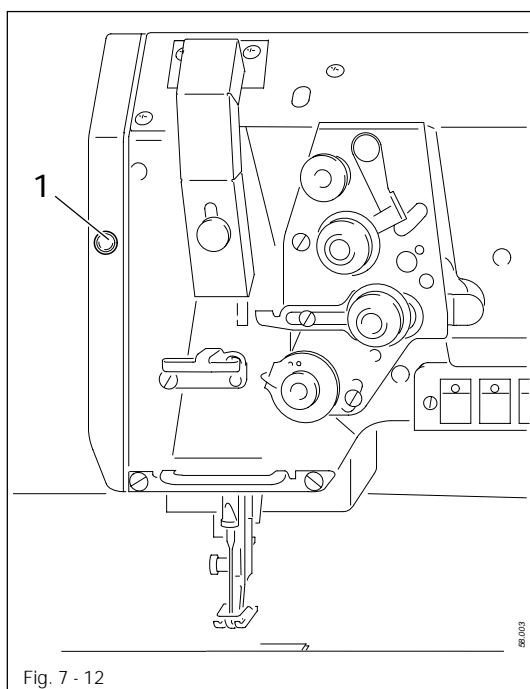

- When the pre-set number of stitches is reached, LED 1 flashes.

After the bobbin has been changed, you must press the "PM" key on the operating panel.

- For pre-setting the number of stitches see Chapter 11.09 Parameter settings.

8 Installation and commissioning



The machine must only be installed and commissioned by qualified personnel! All relevant safety regulations must be strictly adhered to!



If the machine is delivered without a table, be sure to use a stand and table top that can hold the weight of the machine with its motor. It is very important to ensure that the stand of the machine is firm and steady, also during sewing.

8.01 Installation

The site where the machine is installed must be provided with suitable connections for electric current.

It must be ensured that the standing surface of the machine site is firm and horizontal, and that sufficient lighting is provided for.



For packing and transportation reasons the table top is in the lowered position. The table height is adjusted as described below.

8.01.01 Adjusting the table height

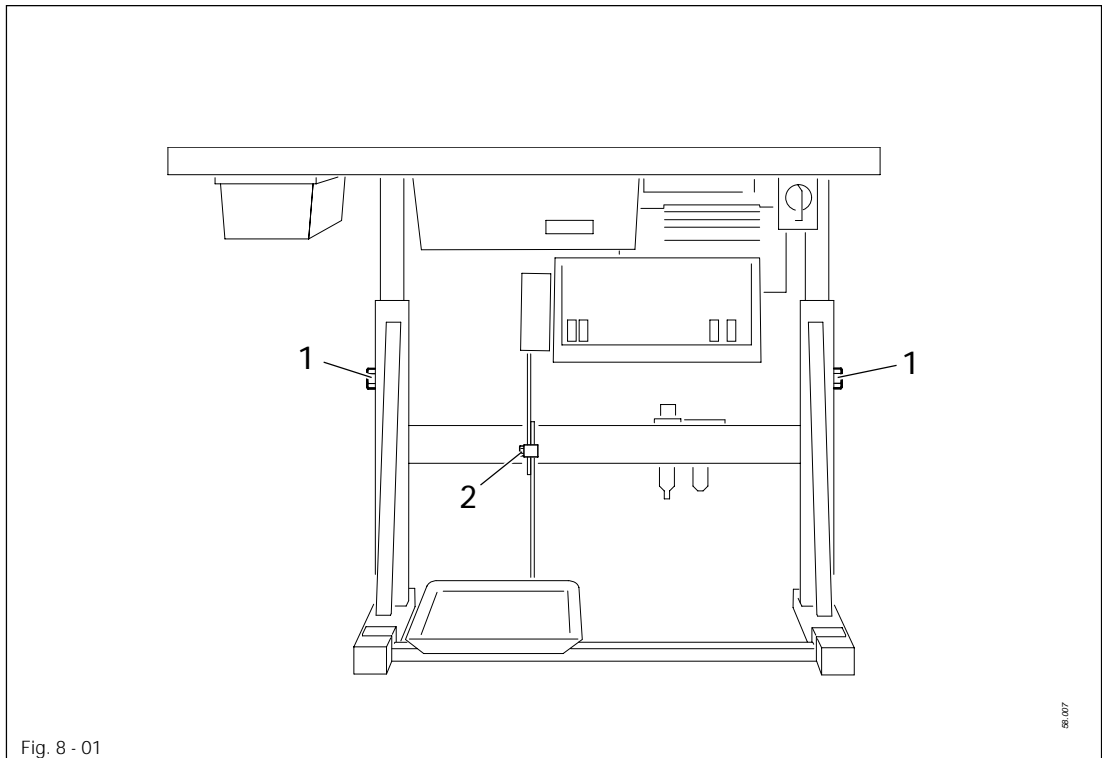

- Loosen screws 1 and 2 and set the table height as required.
- Firmly tighten screw 1.
- Set the required pedal position and tighten screw 2.

8.01.02 Fitting the tilt lock

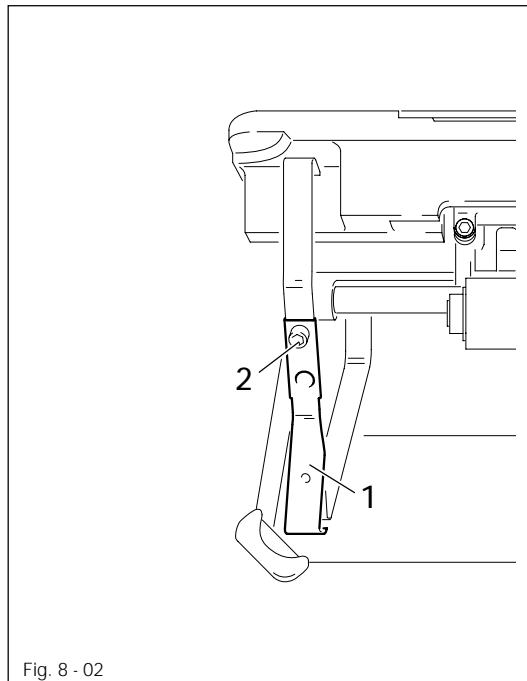

Fig. 8 - 02

- Screw on tilt lock 1, provided in the accessories, using screw 2.



Do not operate the machine without tilt lock 1!
Danger of crushing between sewing head and table top!

8.01.03 Tensioning the v-belt

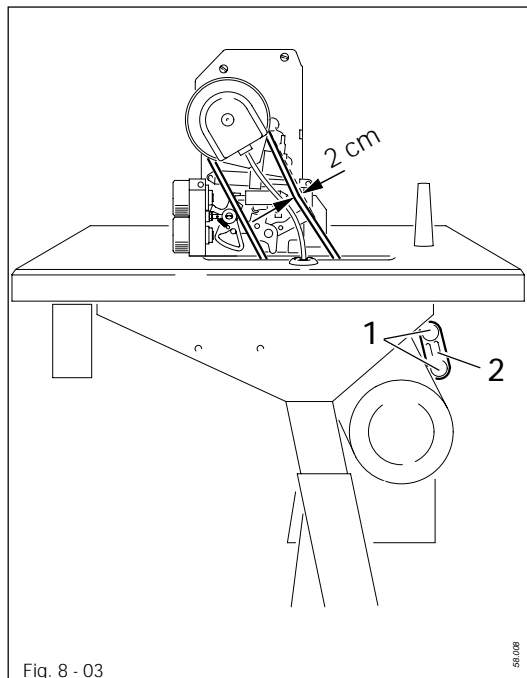
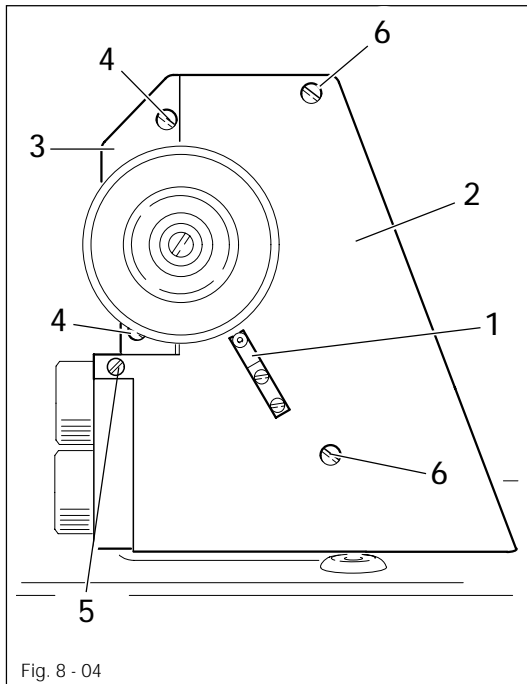

Fig. 8 - 03

- Loosen nut 1.
- Set tension of v-belt by moving motor bracket 2.
- Tighten nuts 1.

8.01.04 Fitting the upper V-belt guard



- Screw position stop 1 to the right belt guard section 2.
- Attach belt guard section 3 with screws 4.
- Push the slots of the right belt guard section 2 behind the heads of retaining screws 6 and attach it with screws 5 and 6.

8.01.05 Fitting the bottom v-belt guard

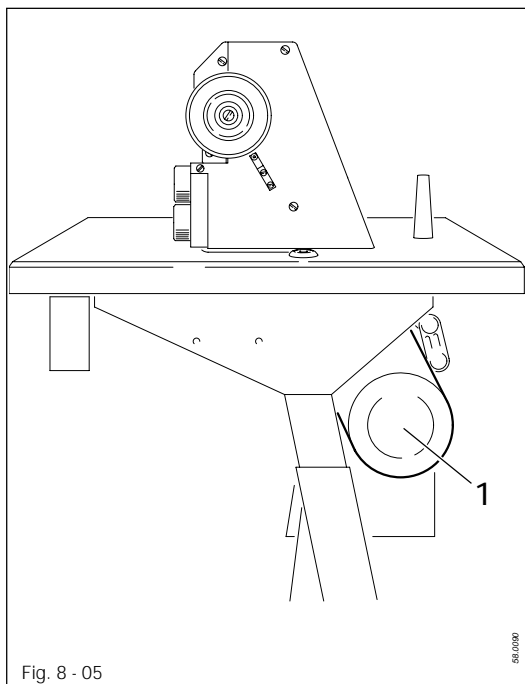

- Position v-belt guard 1 in such a way that motor pulley and v-belt can run freely.



Fig. 8 - 05 shows a Quick motor. If a different motor is used, the instruction manual of the motor must be complied with.

8.01.06 Fitting the synchronizer

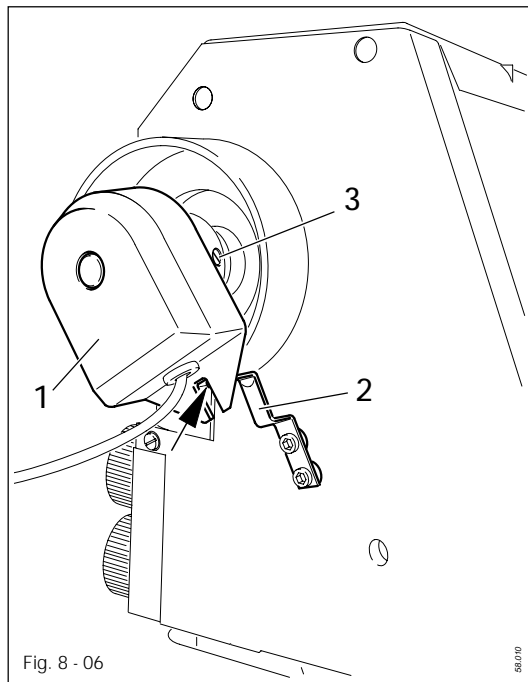

- Push synchronizer 1 onto the shaft so that stop 2 is standing in the slot on the synchronizer (see arrow)
- Tighten screws 3.
- Connect the synchronizer plug to the socket on the control box.
- Adjust the synchronizer (see **Chapter 11.04.01 Adjusting the synchronizer**)

8.01.07 Fitting the reel stand

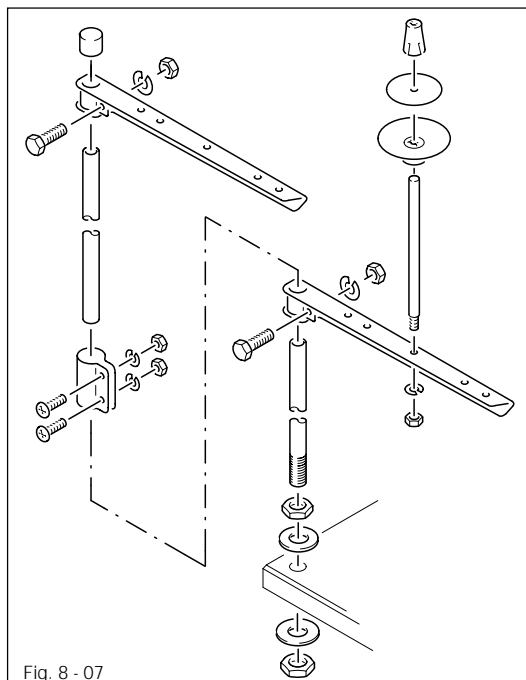

- Fit the reel stand as shown in **Fig. 8 - 07**.
- Afterwards insert the stand in the hole in the table top and secure it with nuts provided.

8.01.08 Connecting the earth cables

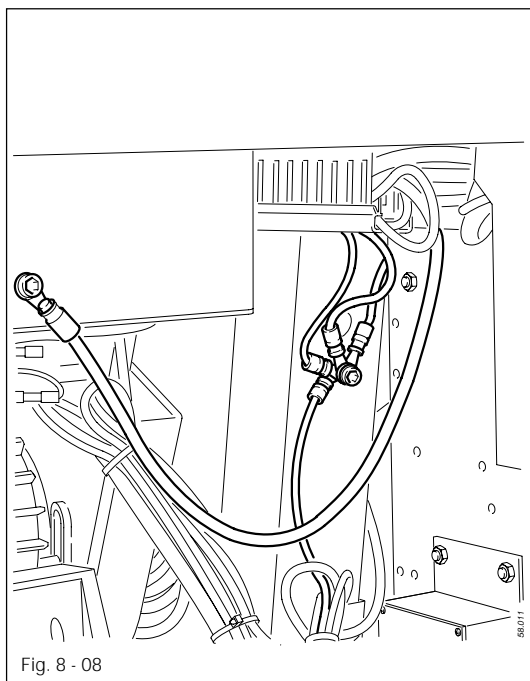

- Connect all the couplers coming from the machine in the control box as designated.
- Screw attach the earth cables from the sewing head, motor, on-off switch and work aids to the frame.

8.02 Commissioning

- Check the machine, particularly its electrical wiring and pneumatic tube connections, for any damage.
- Clean the machine thoroughly and afterwards fill with oil and oil the machine (see **Chapter 10, Care and maintenance**).
- Have a mechanic check whether the motor of the machine can be used with the available power supply and that the motor is correctly connected in the junction box. Do not operate the machine if there is any discrepancy.
- When the machine is running, the balance wheel must turn towards the operator. If it does not, have the motor connection changed by a mechanic.
- Connect the machine to the compressed air supply. When it is connected, the gauge should indicate a pressure of approx. 6 bar. If necessary have this reading correctly set (see **Chapter 10.03, Checking/adjusting the air pressure**).
- Before commissioning the machine, remove grommet 1 of oil container 2.

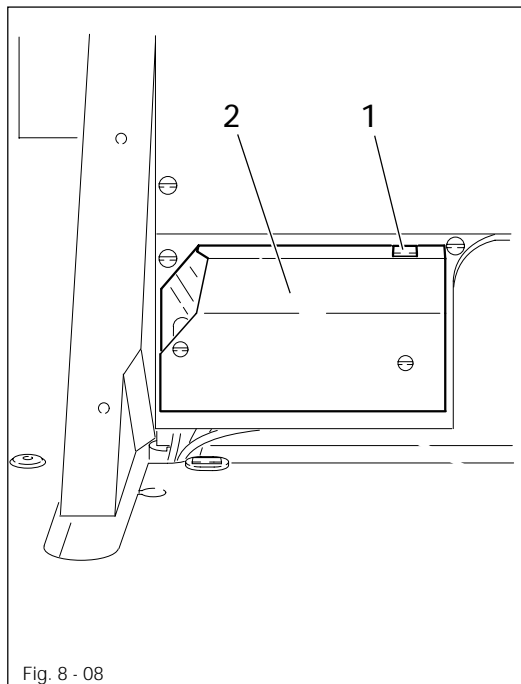

Grommet 1 is only needed for support during transportation and must not be used while the machine is in operation.

8.03 Switching the machine on/off

- Switch the machine on (see **Chapter 7.01, On/off switch**).
- Carry out a running test.

9

Setting up



All instructions and regulations in this instruction manual must be observed. Special attention must be given to all safety regulations!



All setting-up work must only be done by personnel with the necessary training. For all setting-up work the machine must be isolated from its power supply by turning off the on/off switch or removing the machine plug from the electric power socket!

9.01

Inserting the needle on the PFAFF 1425

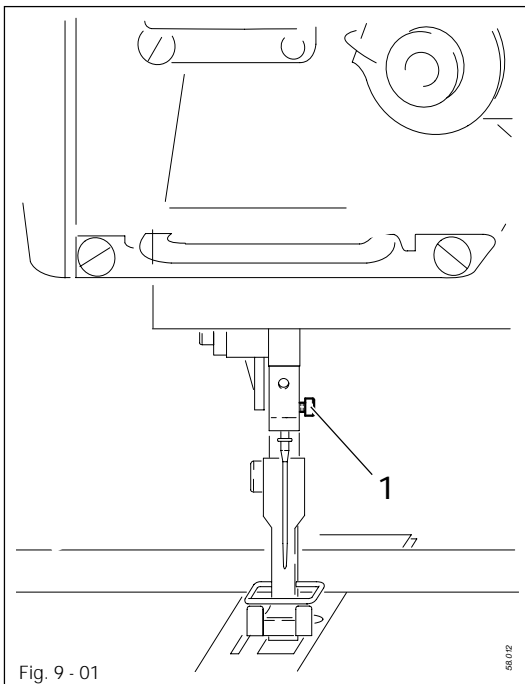

Switch the machine off!
Danger due to unintentional starting of the machine!

Only use needles of system 134-35.

- Set needle bar at top position and loosen screw 1.
- Push the needle fully in (the long needle groove must face to the left).
- Tighten screw 1 again.



If the needle bar is adjusted accordingly, it is also possible to use needle system 134.

The choice of needle depends on the model of the machine and the thread and material used for sewing (see **Chapter 3, Specifications**).

9.02

Inserting the needles on the PFAFF 1426

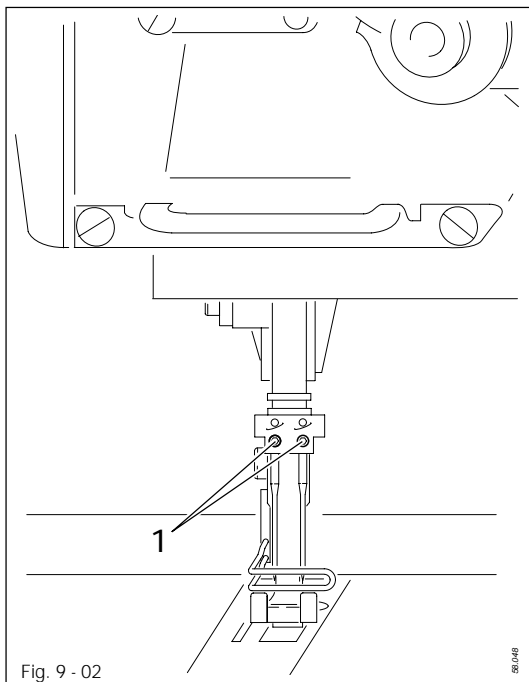

Switch the machine off!
 Danger due to unintentional starting of the machine!

Only use needles of system 134-35!

- Set needle bar at top position and loosen screw 1.
- Push the needle fully in (the long groove of the left needle must face to the right and that of the right needle to the left).
- Tighten screw 1 again.



If the needle bar is adjusted accordingly, it is also possible to use needle system 134.

The choice of needle depends on the model of the machine and the thread and material used for sewing (see Chapter 3, Specifications).

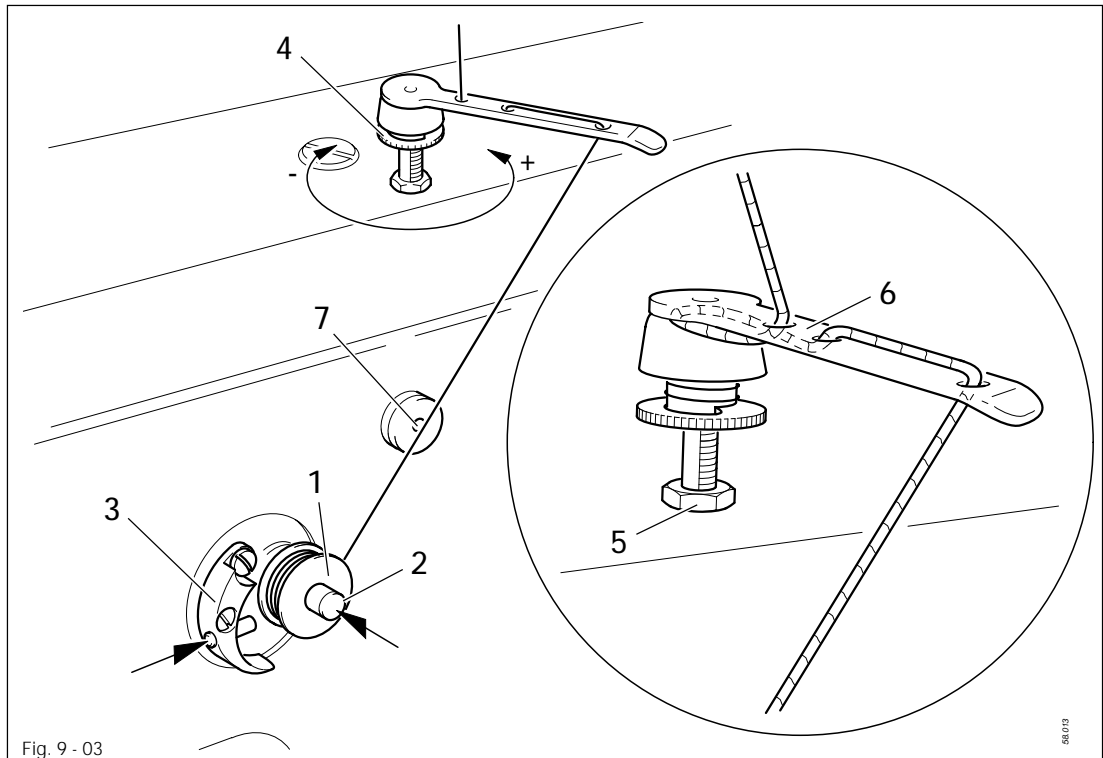

Fig. 9 - 03

66/03

- Place an empty bobbin 1 on winder spindle 2.
- Thread up as shown in Fig. 9 - 03 and wind the thread a few times clockwise around bobbin 1.
- Engage the bobbin winder by pressing spindle 2 and lever 3 simultaneously.



The bobbin is wound during sewing.

- The tension of the thread wound onto bobbin 1 is set on milled screw 4.
- The bobbin winder will stop when sufficient thread is wound onto bobbin 1.
- Guide the thread under thread knife 7 and cut it off, whereby the end of the thread is fastened.

If the thread is wound on unevenly:

- Loosen nut 5.
- Turn thread guide 6 as required.
- Tighten nut 5 again.

9.04

Bobbin-changing/threading, and regulating the bobbin thread tension

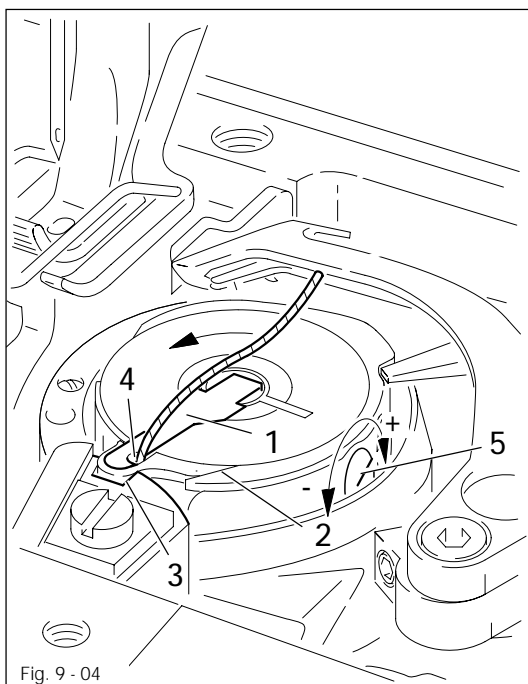

Switch the machine off!
 Danger due to unintentional starting of the machine!

- Set take-up lever at its top position.
- Open bed slide, lift latch 1 and take out the bobbin. Place the filled bobbin into the hook so that the bobbin turns as shown by the arrow when the thread is pulled.
- Close latch 1 again.
- Pull the thread through slot 2, around stop 3 and into hole 4. Close the bed slide again.
- Regulate the bobbin-thread tension by turning screw 5.



Do not run the machine with the bed slide open.
 Danger of injury by moving parts.

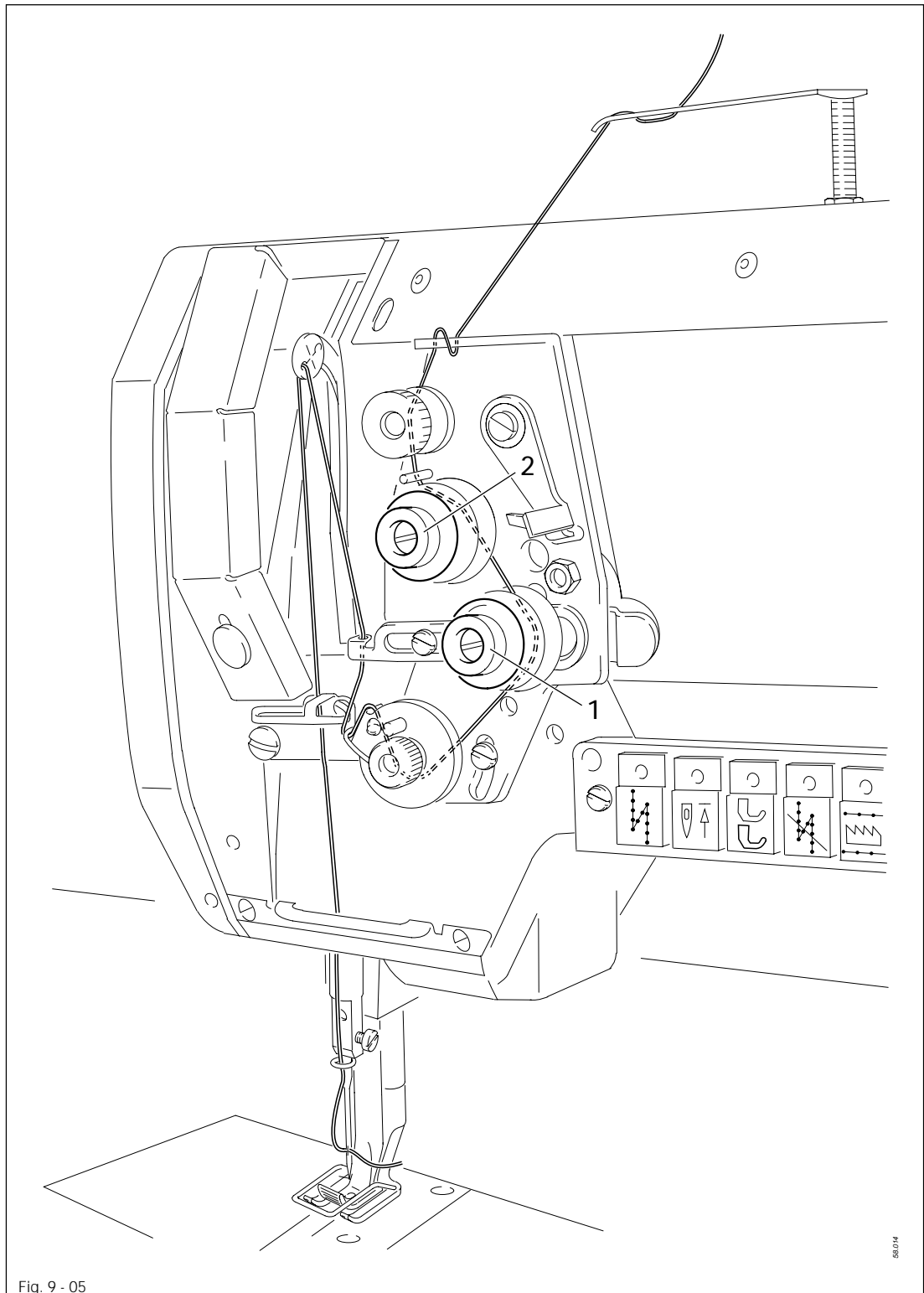

Fig. 9 - 05



Switch the machine off!

Danger due to unintentional starting of the machine!

- Thread the needle thread as shown in Fig. 9 - 05.
- Regulate the needle-thread tension by turning milled screw 1 or 2.

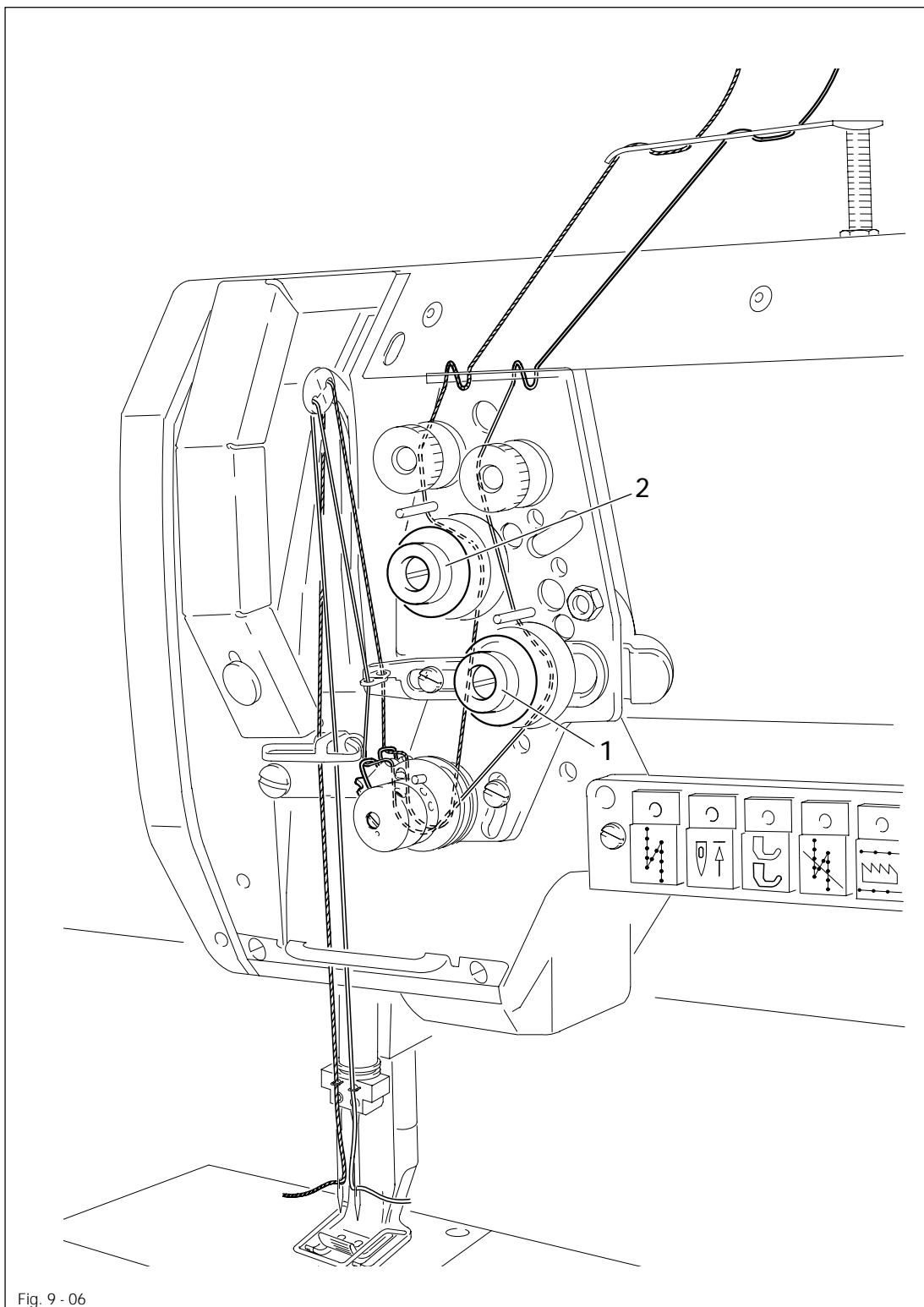

Fig. 9 - 06



Switch the machine off!
 Danger due to unintentional starting of the machine!

- Thread the needle thread as shown in Fig. 9 - 06.
- Regulate the needle-thread tension by turning milled screw 1 (right needle) or 2 (left needle).

10 Care and maintenance

Clean hook area	daily; more frequently if in continuous operation
Check oil level (hook-oil container)	daily, before operation
Check/adjust air pressure	daily, before operation
Clean air filter of air-filter/lubricator	when required



These maintenance intervals apply to the average machine running time in single-shift operation. If machine running times are increased, it is advisable to shorten these intervals.

10.01 Cleaning the hook area

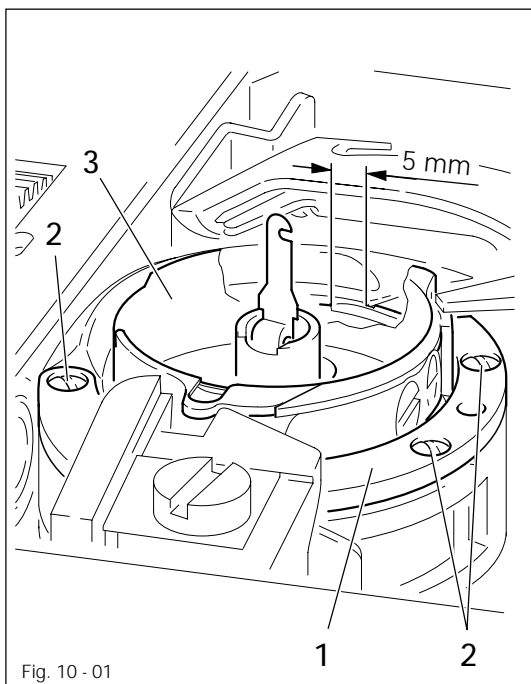

Switch the machine off!
Danger due to unintentional starting of the machine!

- Set needle bar at its top position.
- Open bed slide and take out bobbin..
- Unscrew and remove hook gib 1 (screws 2).
- Turn the balance wheel until the tip of bobbin case 3 has entered the groove in the hook race by about 5 mm .
- Take out bobbin case 3.
- Clean the hook race.
- When inserting bobbin case 3 make sure that the lug of bobbin case 3 en-gages the cutout in the bobbin-case position stop.
- Screw on hook gib 1.
- Insert the bobbin and close the bed slide.

10.02 Oiling the hook

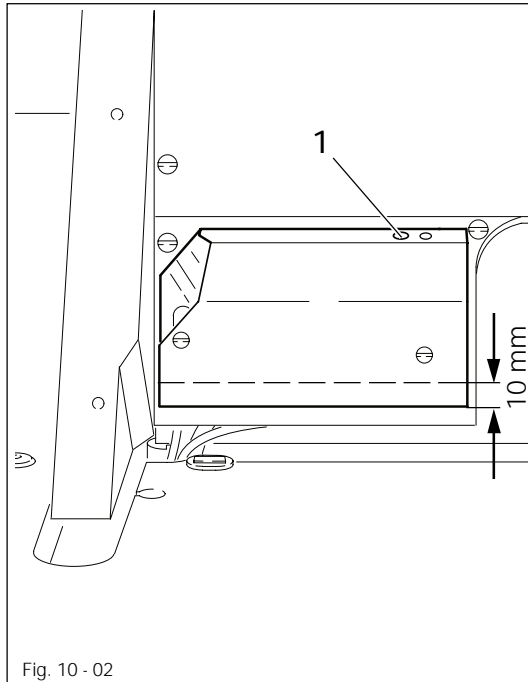

Fig. 10 - 02

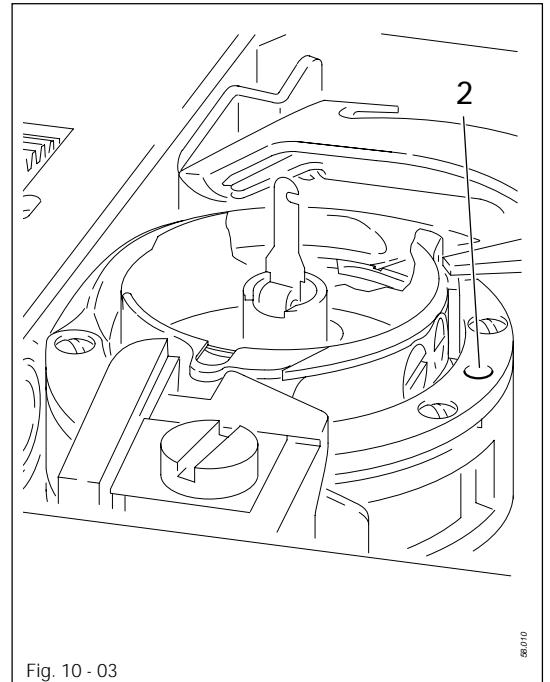

Fig. 10 - 03



Switch the machine off!
 Danger of injury due to unintentional starting of the machine!



Always check the oil level before starting operation.
 The oil level must be at least **10 mm**.

- Top up the oil through hole **1** in the oil reservoir when required.
- Before commissioning the machine, and after longer periods out of operation, apply **1 to 2 drops** of oil in hole **2** of the hook gib.



Only use oil with a medium viscosity of $22.0 \text{ mm}^2/\text{s}$ at 40° C and a density of 0.865 g/cm^3 at 15 C .

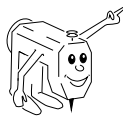

We recommend PFAFF sewing machine oil, No. 280-1-120 144.

10.03 Checking/adjusting the air pressure

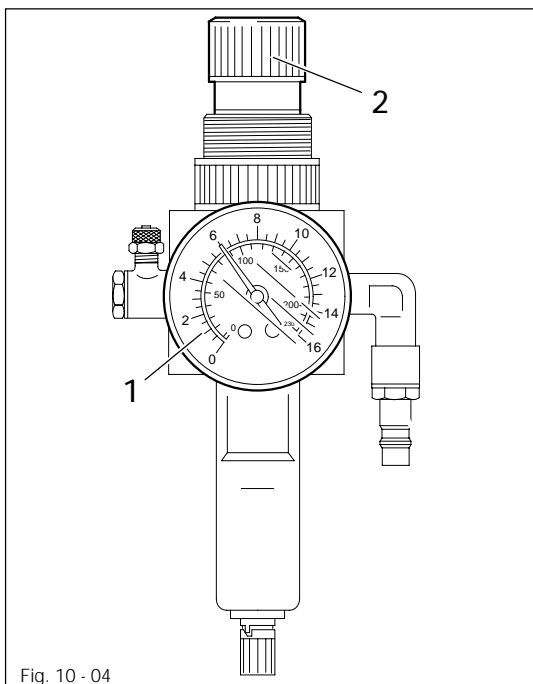

Fig. 10 - 04

- Before operating the machine, always check the air pressure on gauge 1.
- Gauge 1 must show a pressure of 6 bar.
- If necessary adjust to this reading.
- To do so, pull knob 2 upwards and turn it so that the gauge shows a pressure of 6 bar.

10.04 Cleaning the air filter of the air-filter/lubricator

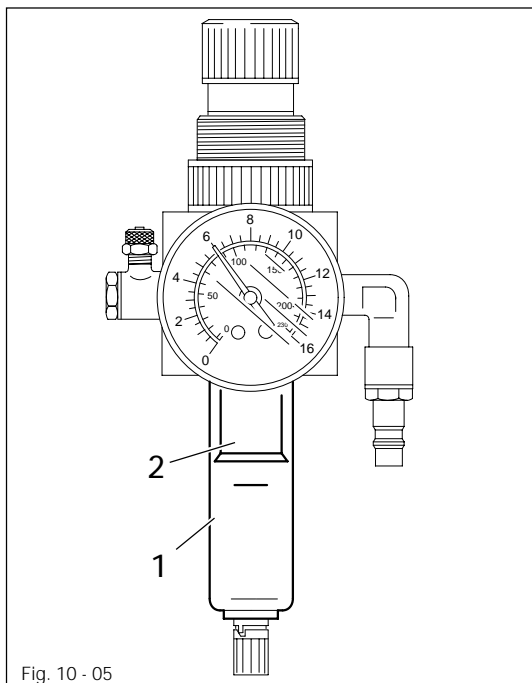

Fig. 10 - 05



Switch the machine off!
Disconnect the air hose at the
air-filter/lubricator.

To drain water bowl 1:

- Water bowl 1 drains itself automatically when the compressed-air hose is disconnected from the air-filter/lubricator.

Cleaning filter 2:

- Unscrew water bowl 1.
- Take out filter 2.
- Clean filter 2 with compressed air or isopropyl alcohol (part No. 95-665 735-91).
- Screw in filter 2 and screw on water bowl 1.

11 Adjustment



The illustrations in this chapter show the single-needle machine, **PFAFF 1425-900/81**. For the two-needle machine, **PFAFF 1426**, various adjustments have to be made twice, i.e. on the left- and right-hand sewing hooks. This is pointed out in the chapters concerned, and some of the illustrations have to be regarded in reverse.

11.01 Tools, gauges and other equipment

- Set of screwdrivers with 2 to 10 mm blade widths
- Set of open-ended spanners/wrenches, 7 to 14 mm across flats
- Set of allen keys from 2 to 6 mm
- Needle rise gauge (Part No. 61-111 600-01)
- Screw clamp (Part No. 61-111 600-35/001)
- 7.0 mm gauge for presser-foot height (part No. 61-111 633-61)
- 5.0 mm gauge for top feed stroke (part No. 61-111 633-60)
- Metal rule (part No. 08-880 218-00)
- Needles, System 134-35
- Sewing thread and test material

11.02 Notes on adjustment

- All adjustments in these adjustment instructions are based on a fully assembled machine.
- Machine covers that have to be removed and replaced to carry out checks and adjustments are not mentioned in the text.
- Screws, nuts and other means of fixation for machine parts indicated in the text in brackets () are to be loosened before the adjustment and tightened again afterwards.

11.03 Abbreviations

t.d.c. = top dead centre

b.d.c. = bottom dead centre

Adjustment

11.04 Adjusting the basic machine

11.04.01 Adjusting the synchroniser

Requirement

1. At a seam interruption the machine must position the needle bar at 4 mm past b.d.c.
2. After thread trimming the machine must position the take-up lever at t.d.c.

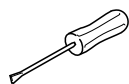
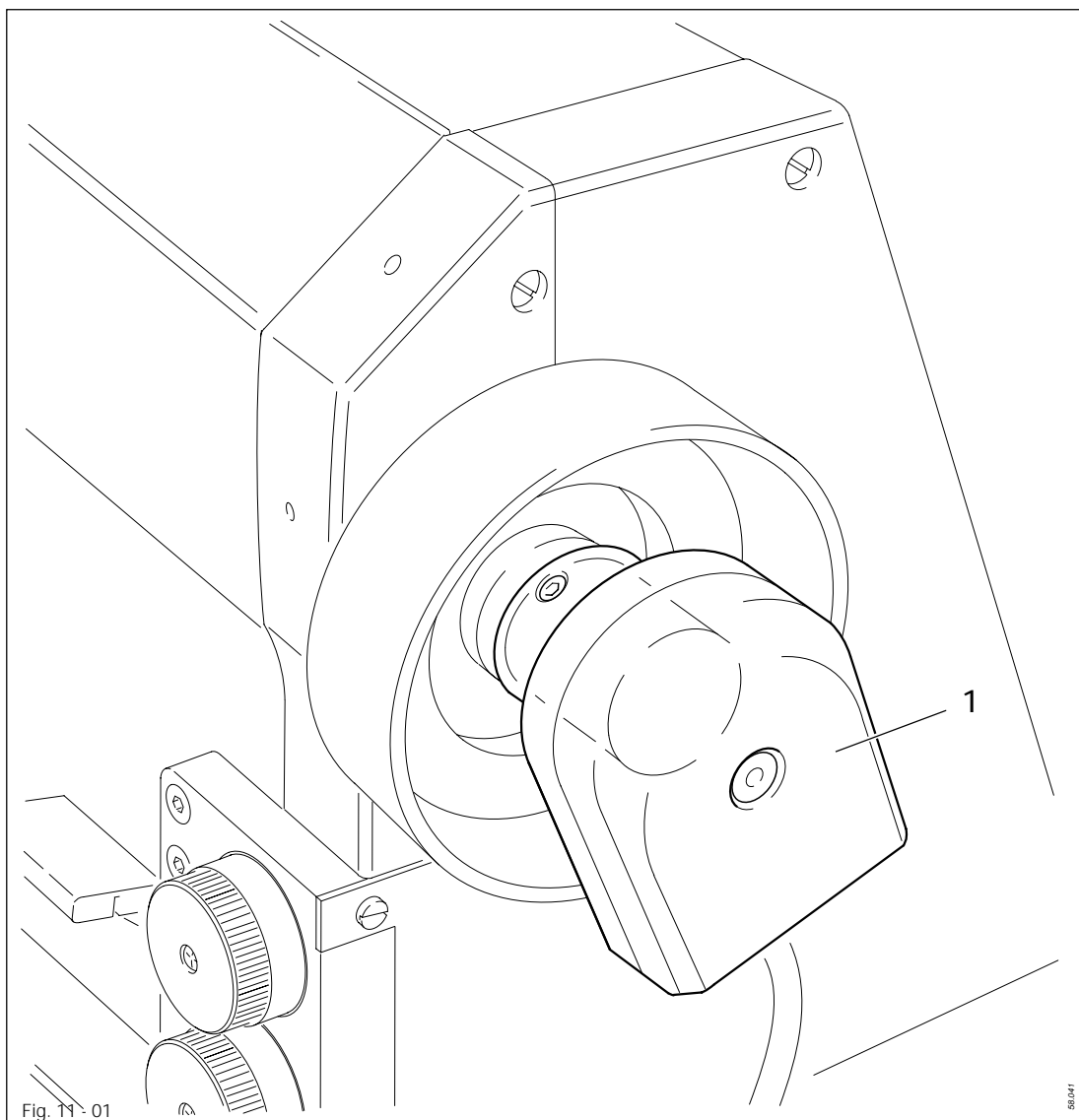

- Carry out adjustments on the synchroniser 1 according to the motor instruction manual. Also see Chapter 11.09 Parameter settings.

11.04.02 Balance weight

Requirement

At needle bar t.d.c. the eccentric lobe of balance weight 1 must face downwards.

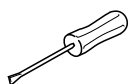
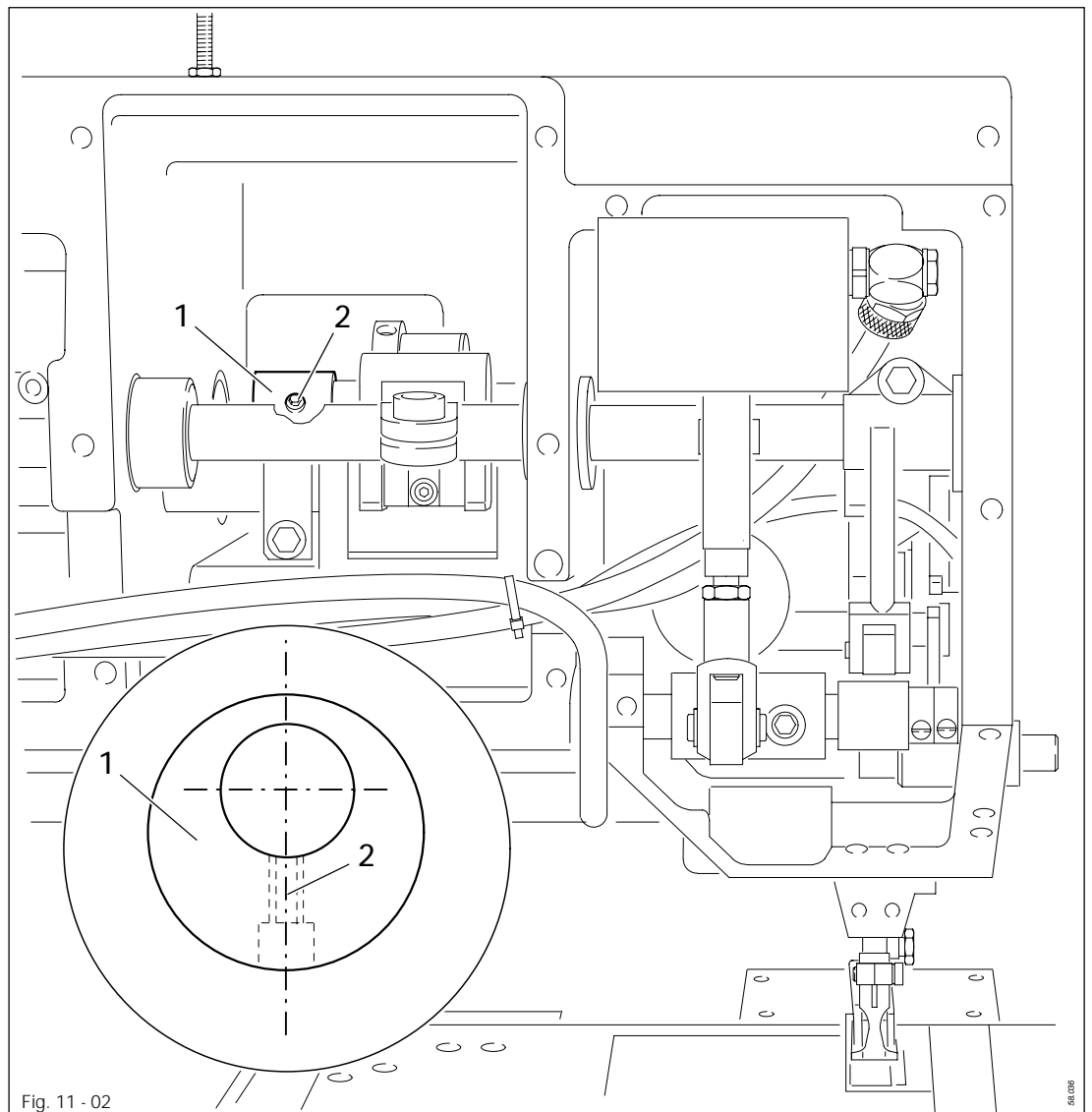

- Adjust balance weight 1 (screw 2) according to Requirement.

Adjustment

11.04.03 Neutral position of unison feed

Requirement

At stitch length setting " 0 " neither the top- and bottom feed dogs nor the needle bar must make any feeding movement.

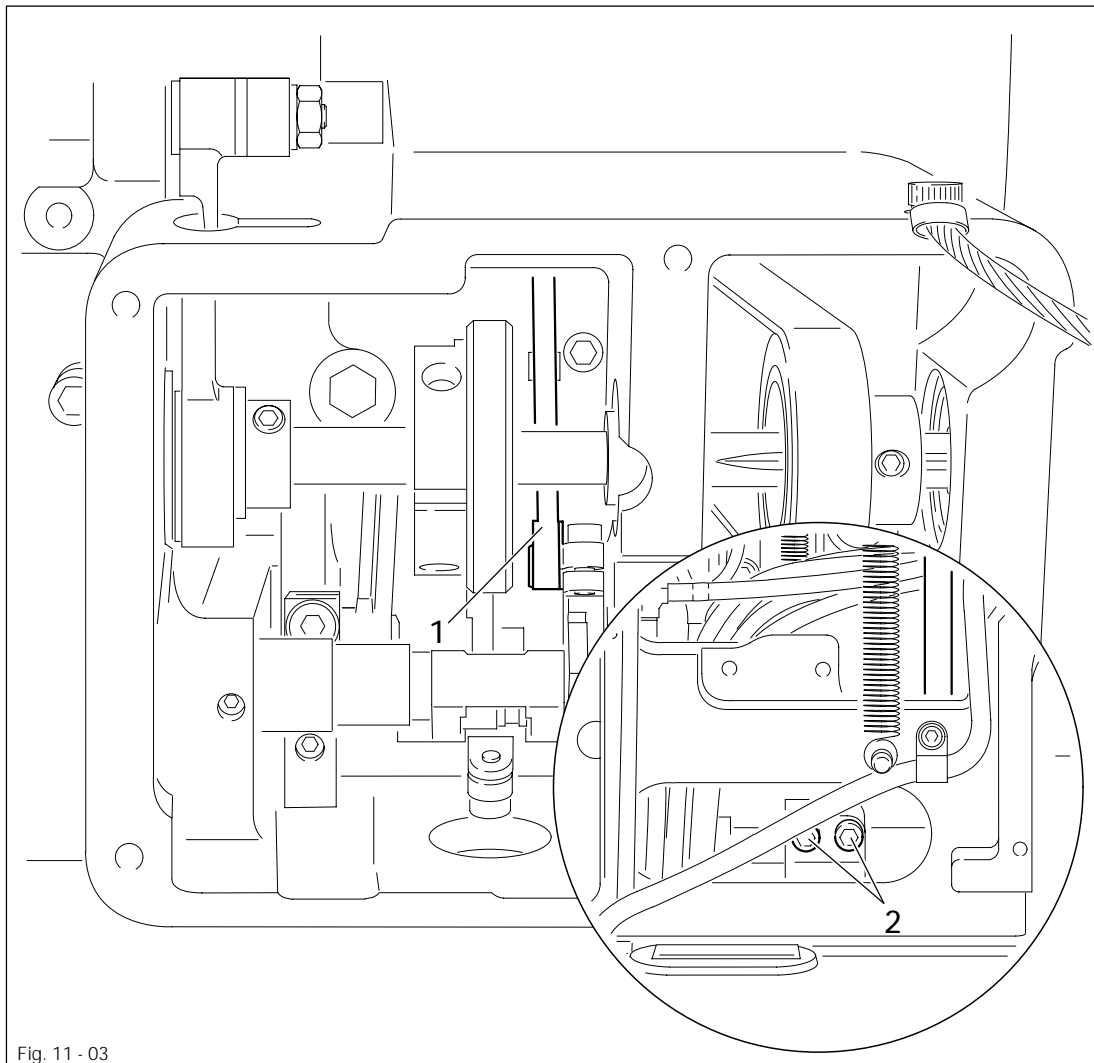
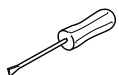

Fig. 11 - 03



- Re-position connecting rod 1 (screws 2) according to Requirement.

11.04.04 Feeding motion of the unison feed

Requirement

At the longest stitch-length setting and at needle bar b.d.c. neither the top- and bottom feed dogs nor the needle bar must make any feeding motion when the reverse-feed lever is pressed.

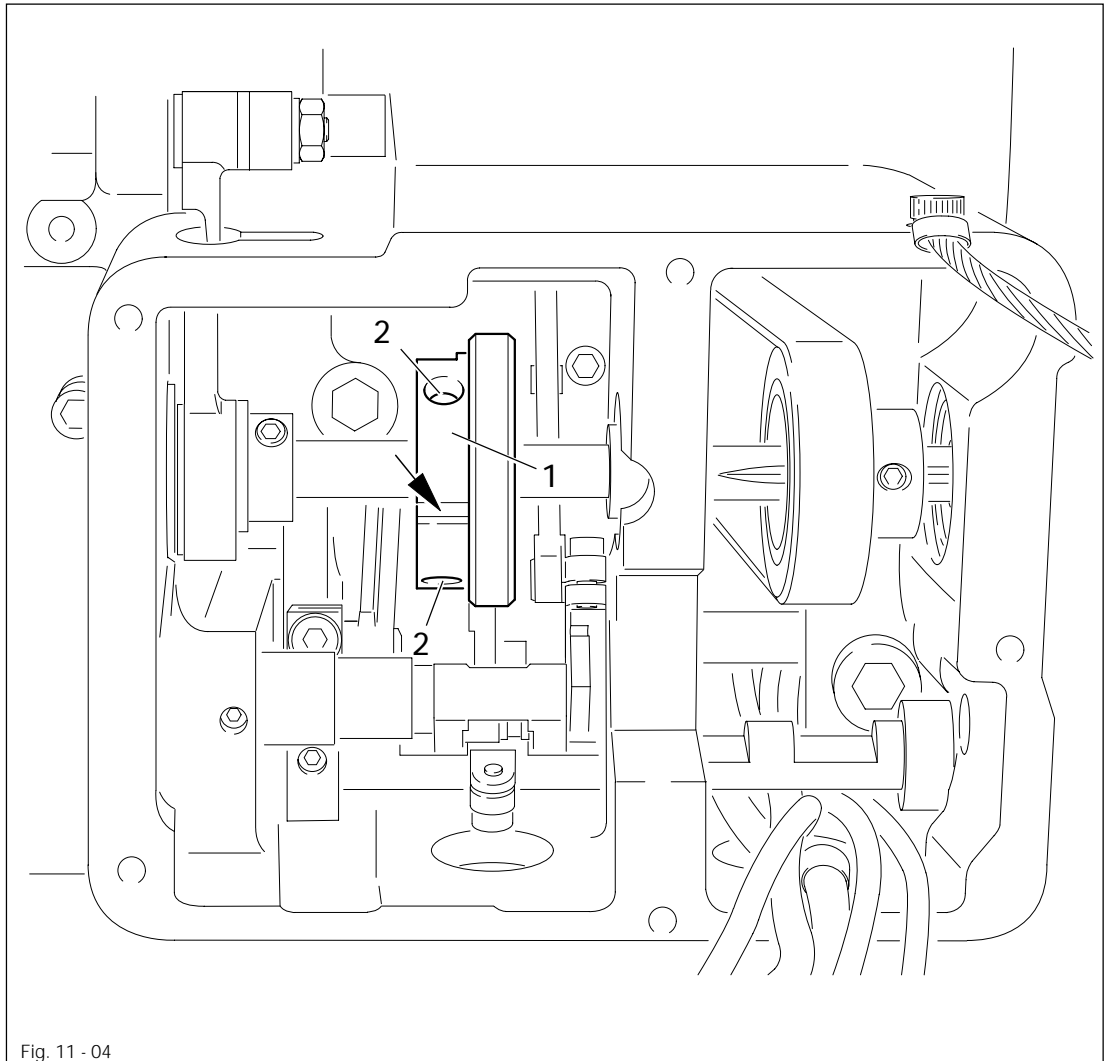
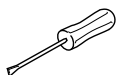

Fig. 11 - 04



- Adjust eccentric 1 (screws 2) according to **Requirement**. Make sure that cut-out (see arrow) is visible.

11.04.05 Lifting motion of the bottom feed dog

Requirement

With the needle bar at b.d.c. the feed dog must be at t.d.c.

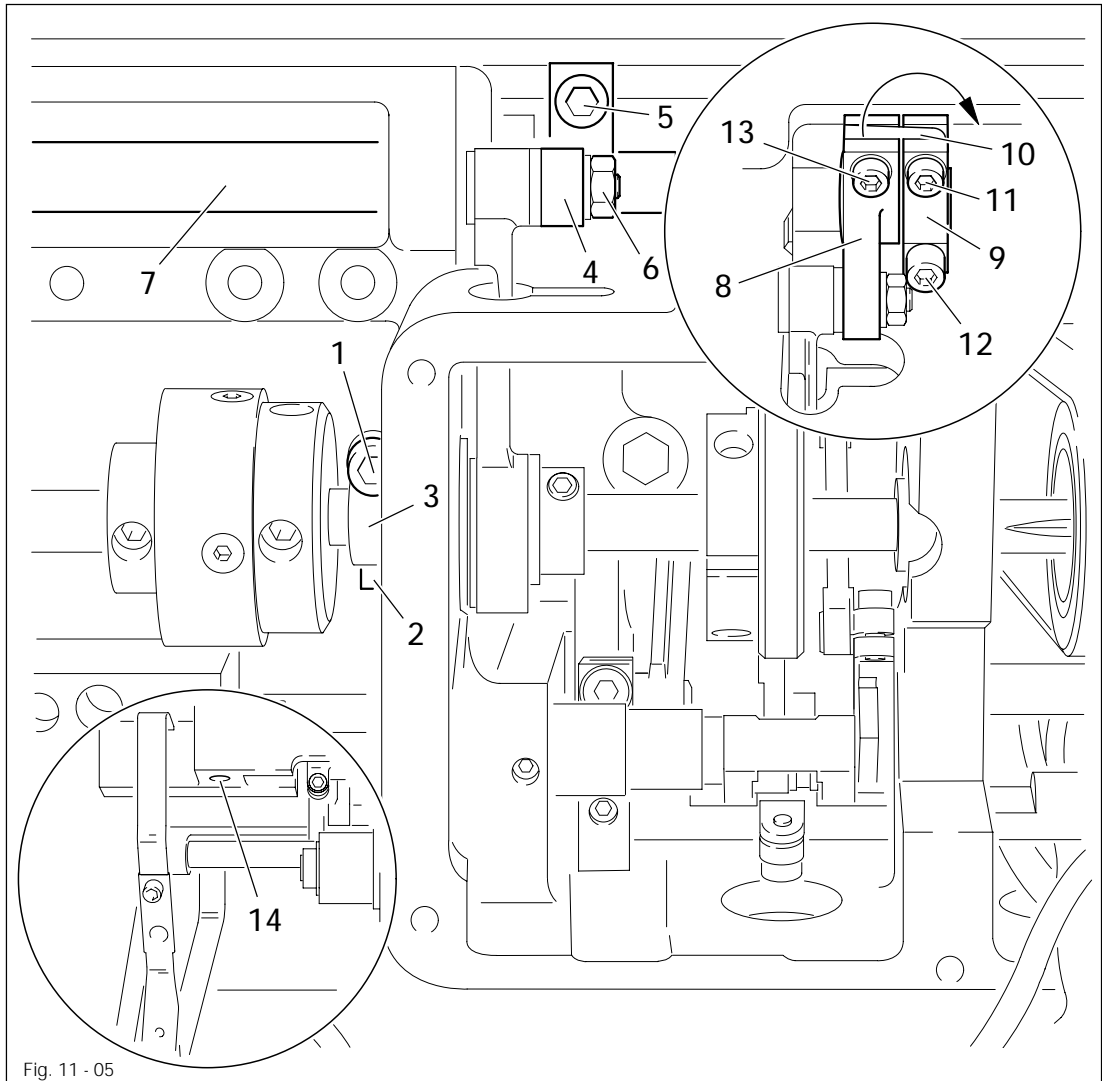
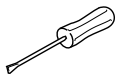

Fig. 11 - 05



- Loosen screw 1 and undo screw 2 a half turn.
- Turn clamp collar 3 according to **Requirement** and first tighten screw 2, then tighten screw 1.



With kit No. 91-266 375-90 it is possible to disengage the lifting motion of the feed dog.

Fitting and adjusting the parts of the kit

- Remove link 4 (screw 5, nut 6).
- Loosen the parts secured to shaft 7 and push shaft 7 to the left a little.
- Place the pre-assembled parts 8 and 9 onto shaft 7.
- Push shaft 7 back and adjust the loosened parts again.

Engaging the lifting motion

- The lifting motion is engaged when parts 8 to 13 are fitted as shown in the upper magnified view.

Disengaging the lifting motion

- Take out screw 13 and swing part 10 to the right (screw 11).
- Set the feed-dog teeth flush with the upper surface of the needle plate and fix shaft 7 in this position by inserting screw 13 into hole 14.
- When the lifting motion is engaged again, there is no need to adjust the bottom feed dog height.

11.04.06 Bottom feed-dog height

Requirement

1. When the needle bar is at b.d.c., the stitch length is set at "0" and crank 5 is at the bottom of the slotted lever (see arrow), the bottom feed dog must protrude from the top surface of the needle plate by 0.5 mm.
2. The bottom feed dog must be centred in the needle-plate slot.

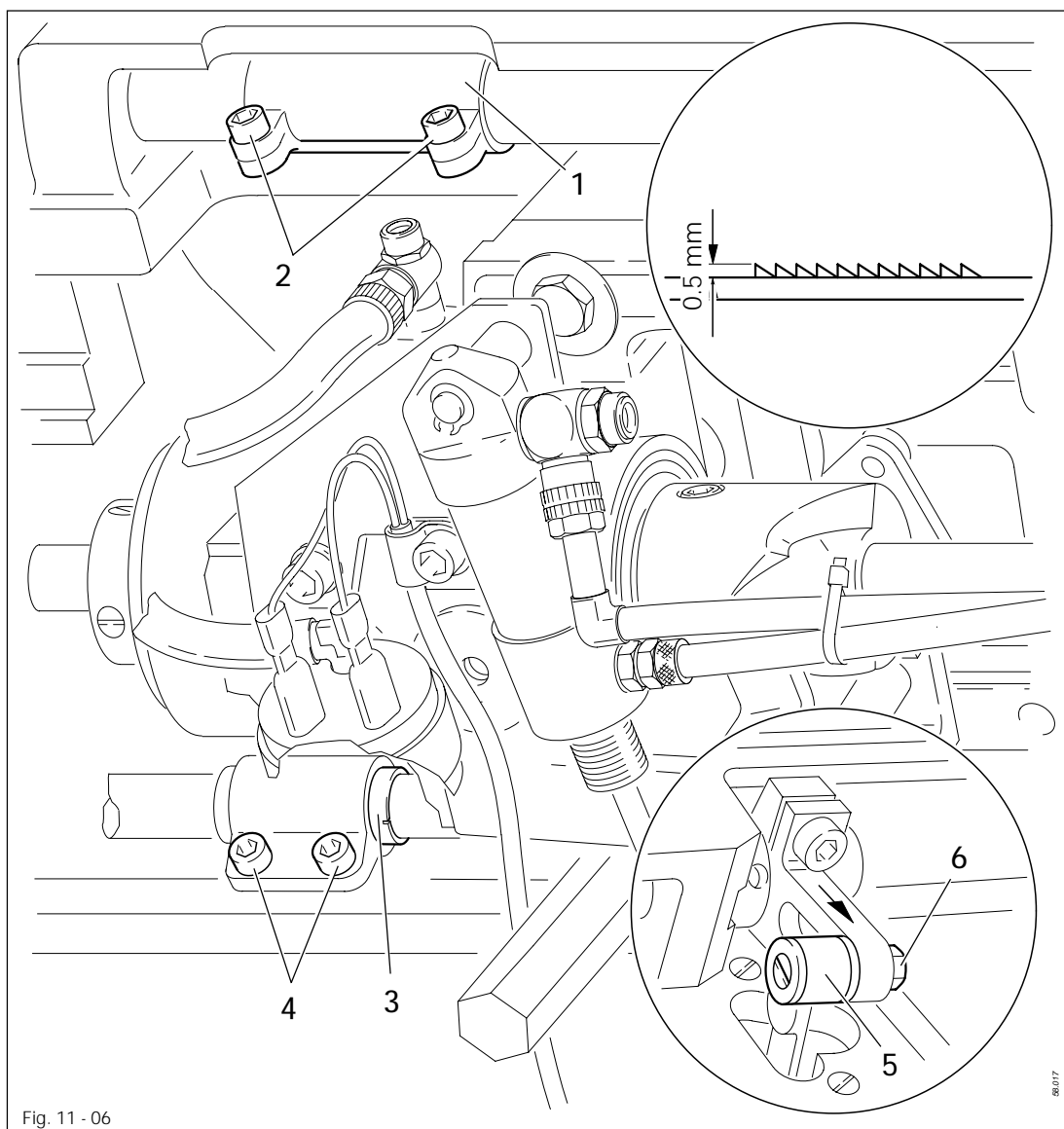
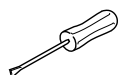

Fig. 11 - 06



- Turn lifting crank 1 (screws 2) and eccentric sleeve 3 (screws 4) according to Requirement 1, and set feed dog in centre of needle-plate slot as shown in Requirement 2.



The feed-dog height can also be increased by shifting crank 5 (nut 6) upwards as required.

11.04.07 Needle in needle-hole centre

Requirement

At stitch length "0" the needle must enter exactly in the centre of the needle hole.

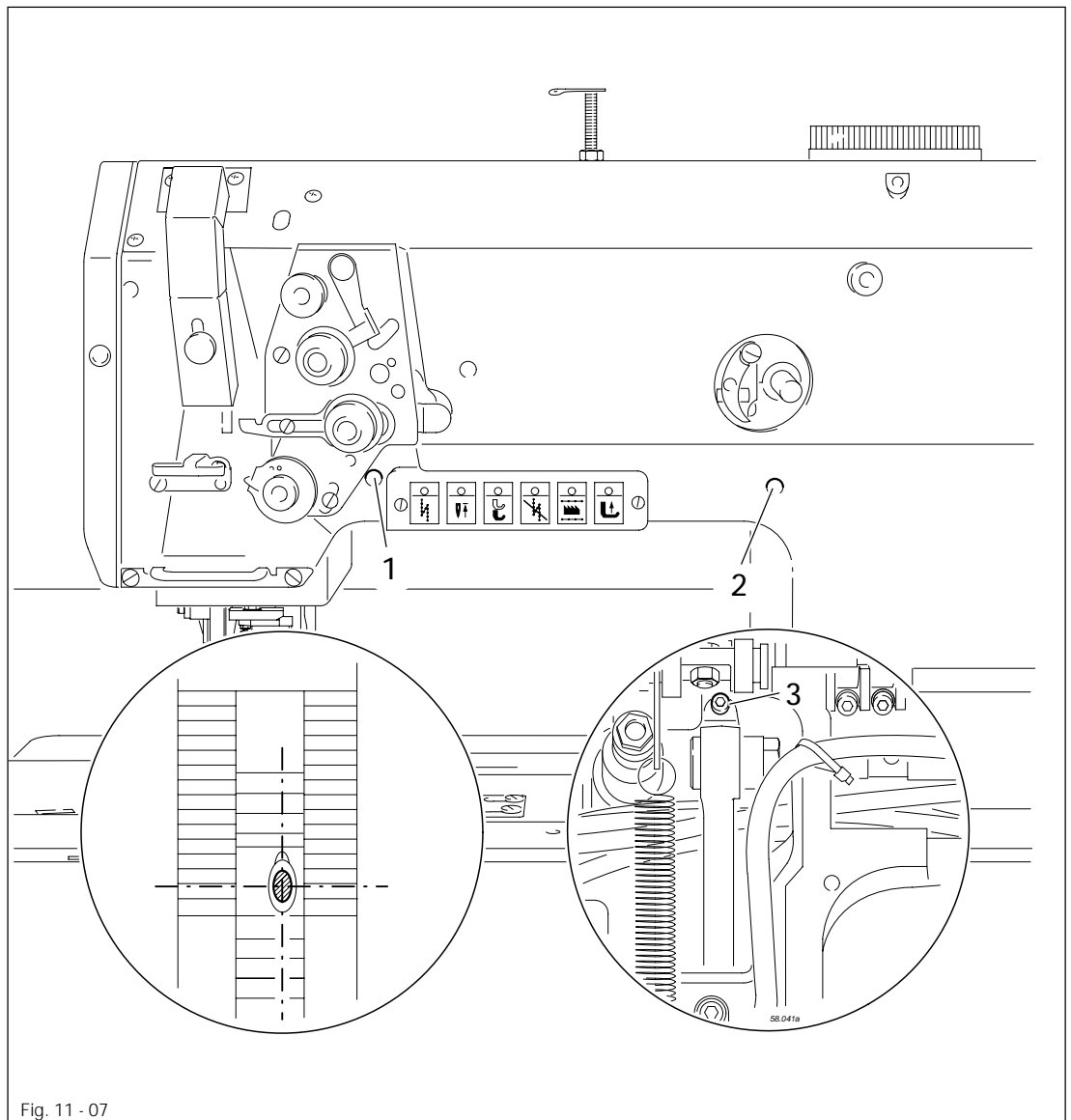
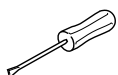

Fig. 11 - 07



- Position the needle-bar frame (screws 1, 2 and 3) according to Requirement.

11.04.08 Feeding-stroke difference

Requirement

At the longest stitch-length setting and when the balance wheel is turned, the feeding strokes of the needle bar and the bottom feed dog must be the same.

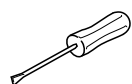
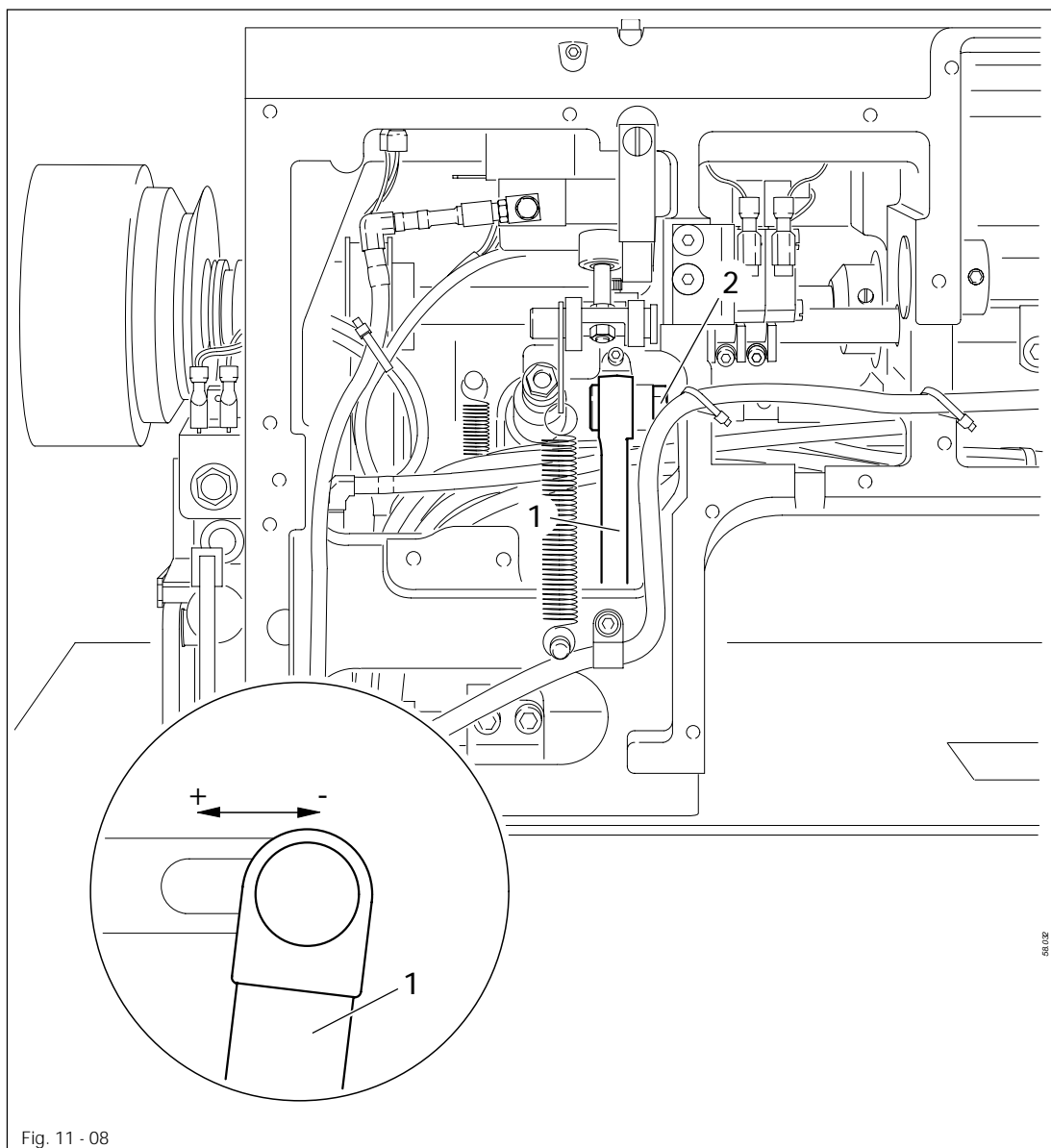

- Reposition connecting rod 1 (nut 2) according to Requirement.
Connecting rod to " + " = longer needle feeding stroke.
to " - " = shorter needle feeding stroke.

11.04.09 Needle height (preliminary adjustment)

Requirement

At needle-bar t.d.c. the clearance between needle point and needle plate must be approx. 19 mm.

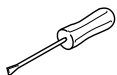
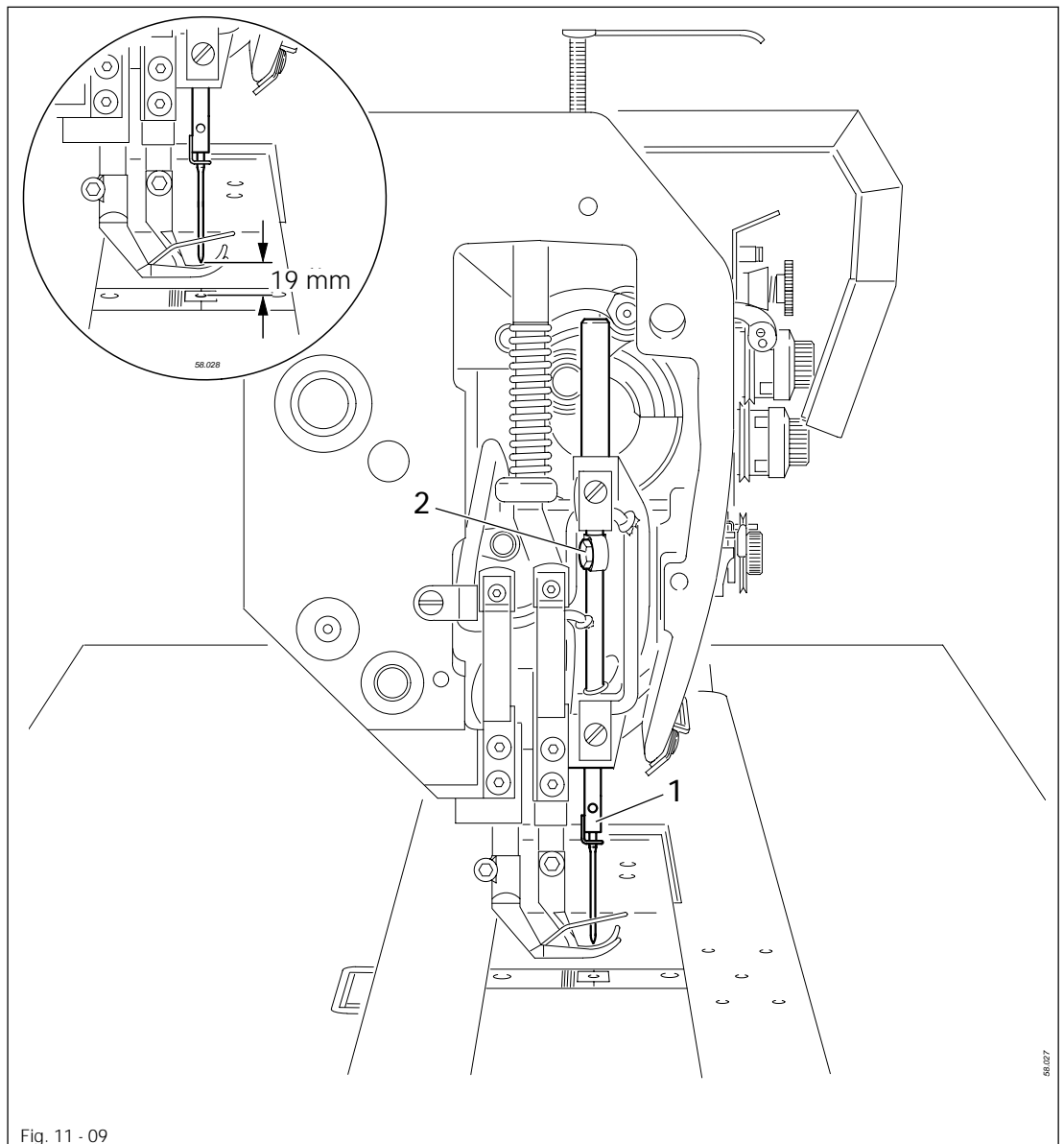

- Re-position needle bar 1 (screw 2), without turning it, according to Requirement.

Adjustment

11.04.10 Needle rise, hook clearance, needle height (final adjustm.) and needle guard
(On the PFAFF 1426 carry out this adjustment on both hooks)

Requirement

At stitch-length setting "4" and needle bar at 2 mm b.d.c.:

1. the hook point must be at "needle centre" with a hook-to-needle clearance of **0.05 to 0.1 mm**;
2. the top of the needle eye must be **0.8 mm** below the hook point;
3. and needle guard **9** must touch the needle just lightly.

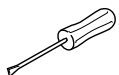
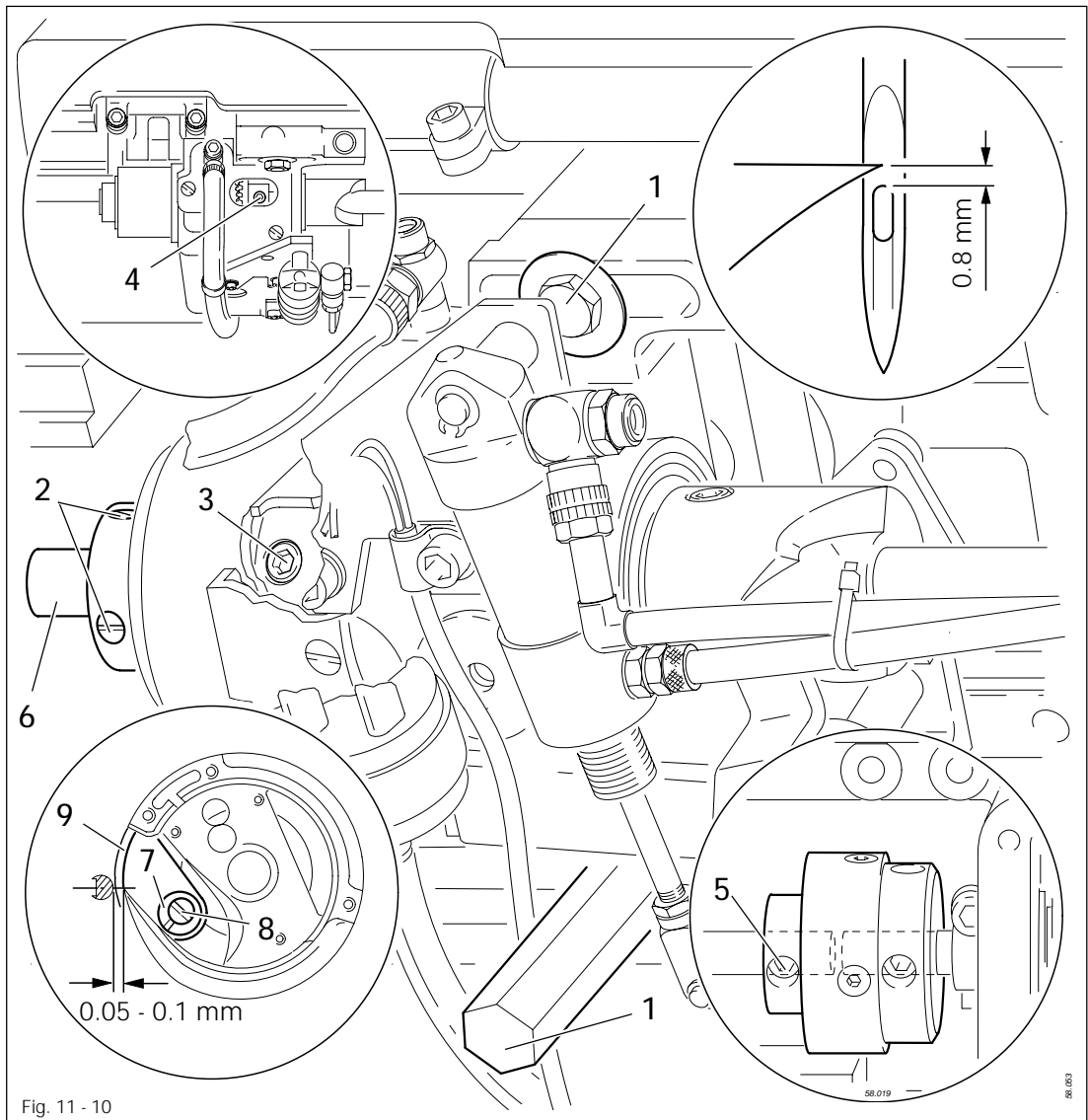

- Set stitch length "4" and loosen screws 1, 2, 3 and 4.
- Set needle bar at 2 mm past b.d.c. and set hook point at "needle centre."
- Set hook clearance according to **Requirement 1** and tighten screws 1.
- Loosen screws 5 and turn shaft 6 so that the shafts in the coupling do not touch each other.
- Tighten screws 2 and 5.
- Making sure there is a slight play in the gear, move the collar up and tighten screws 3.

- Set needle bar at 2 mm past b.d.c. (use screw clamp and needle-rise gauge).
- Set hook point at "needle centre" and tighten screws 4.
- If necessary, readjust needle bar according to **Requirement 2**.
- Remove hook base and turn eccentric 7 (screw 8) according to **Requirement 3**.



On the PFAFF 1426, also loosen screws 1, 2, 3 and 4 on the second hook and carry out the adjustments as described.

Adjustment

11.04.11 Bobbin-case opener stroke (On the PFAFF 1426 carry out this adjustment on both hooks)

Requirement

1. The front edge of retaining spring 1 and stop 7 must be flush.
2. In the rearmost position of the bobbin-case opener, hook base 6 and retaining spring 1 must stand apart by thread thickness X.

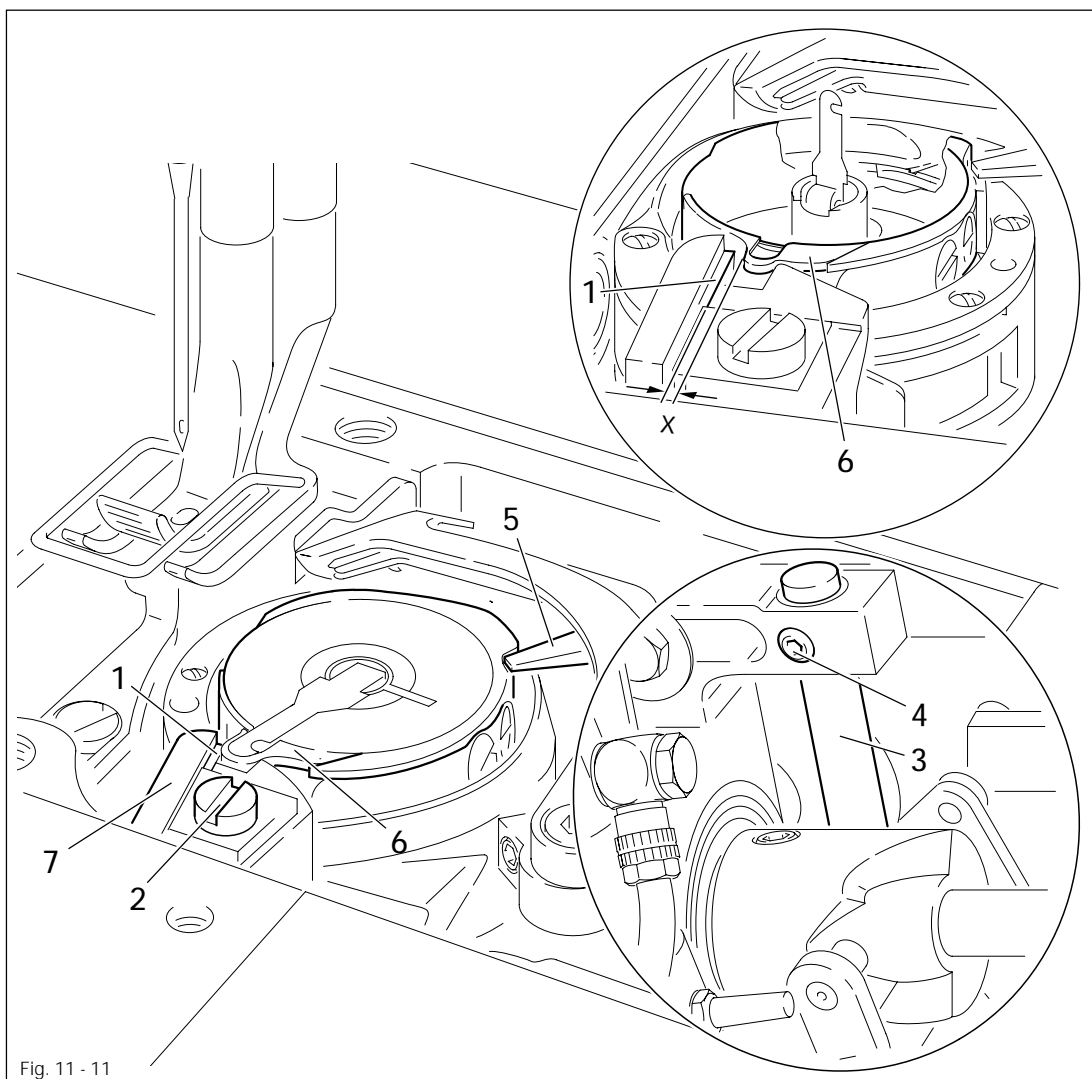
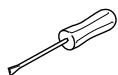

Fig. 11 - 11



- Position retaining spring 1 (screw 2) according to Requirement 1.
- Re-position shaft 3 (screw 4) according to Requirement 2.

11.04.12 Top feed stroke

Requirement

1. With knob 1 set at position "5", the top feed dog 10 and presser foot 11 should each rise by 5.0 mm.
2. The standard stroke should be limited to 5 mm.

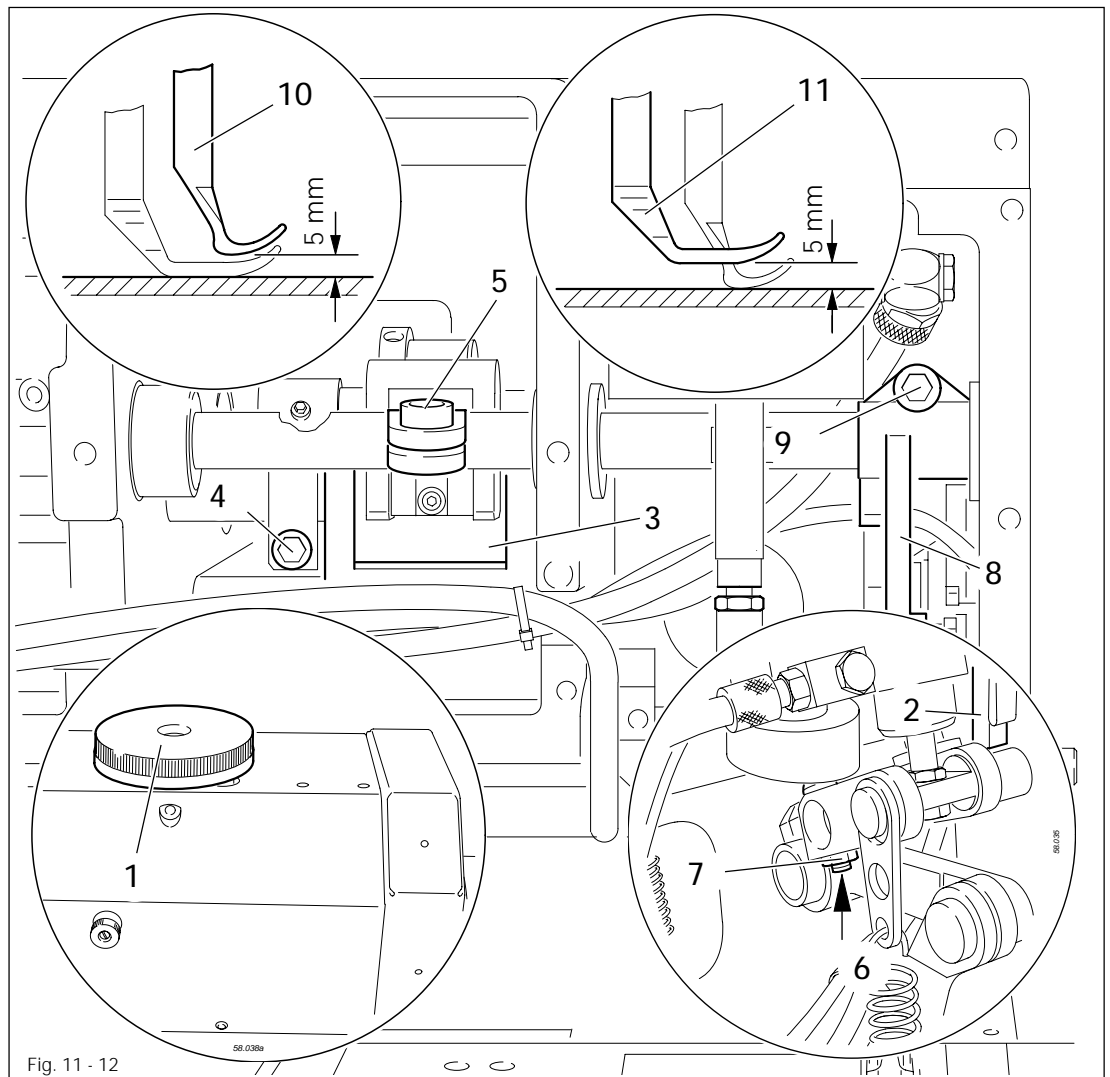
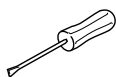

Fig. 11 - 12



- Remove the bottom feed dog and set knob 1 at "0".
- Unscrew the needle plate. Place the metal gauge over the opening of the needle plate cutout so that both sewing feet can rest on the metal gauge.
- Screw in stop screw 2 as far as possible.
- Adjust crank 3 (screw 4) so that crank 5 does not move when the balance wheel is turned.
- Set knob 1 at "5".
- Turn ball stud 6 (locknut 7) according to **requirement 1**.
- Adjust crank 8 (screw 9) so that the top feed dog 10 and presser foot 11 are raised equally from the needle plate.
- Check **requirement 1** and readjust the ball stud 6 (nut 7) if necessary.
- Turn stop screw 2 according to **requirement 2**.

11.04.13 Top-feed lifting motion

Requirement

When a lifting-presser stroke of **3 mm** is set and the descending needle is **3 mm** above the needle plate, the vibrating presser must just reach the needle plate.

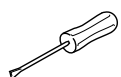
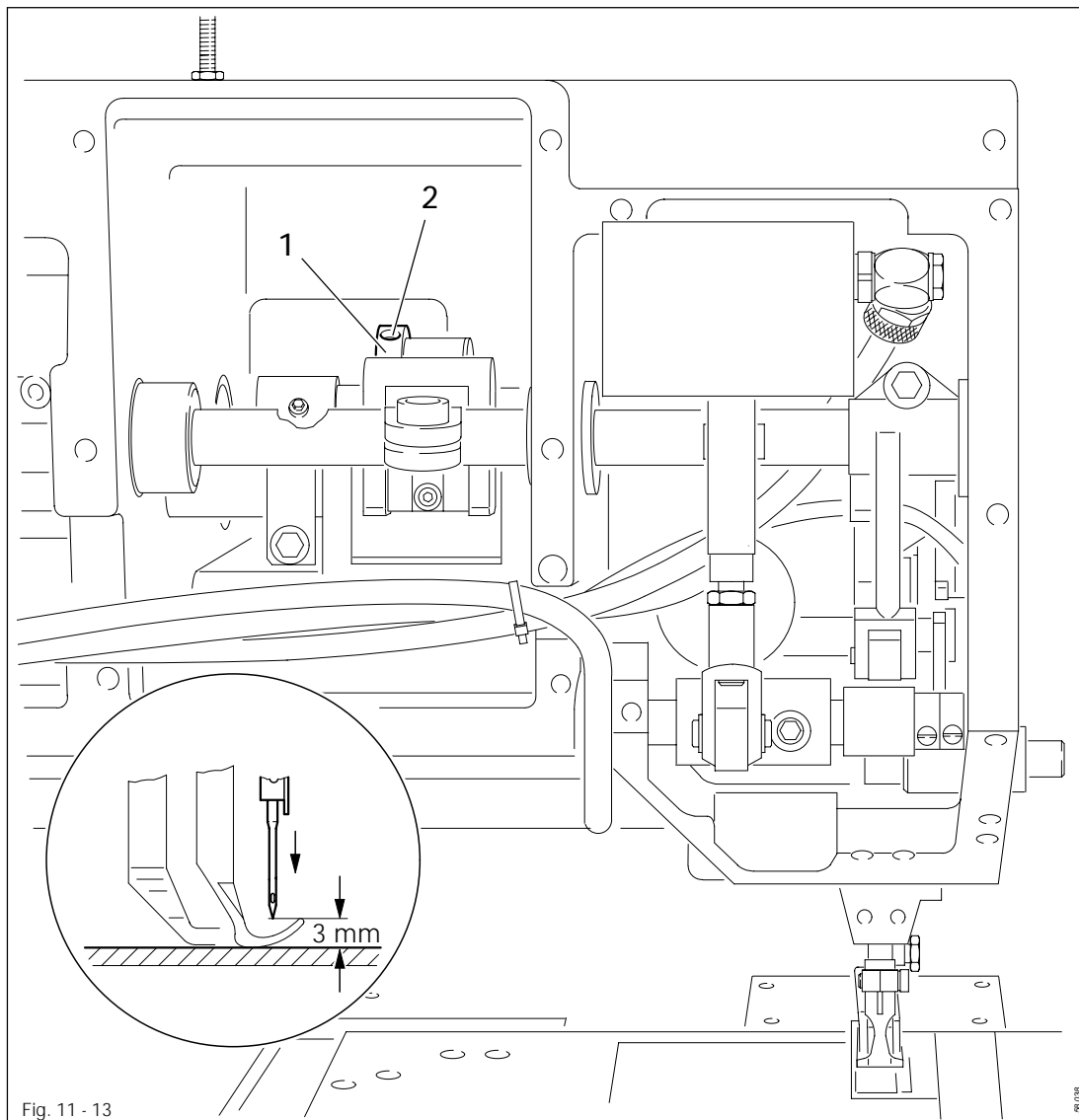

- Turn eccentric 1 (screws 2) according to Requirement.

11.04.14 Clearance between lifting presser and needle plate

Requirement

With the lifting presser raised there must be a clearance of approx. **16 mm** between lifting presser and needle plate.

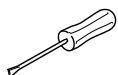
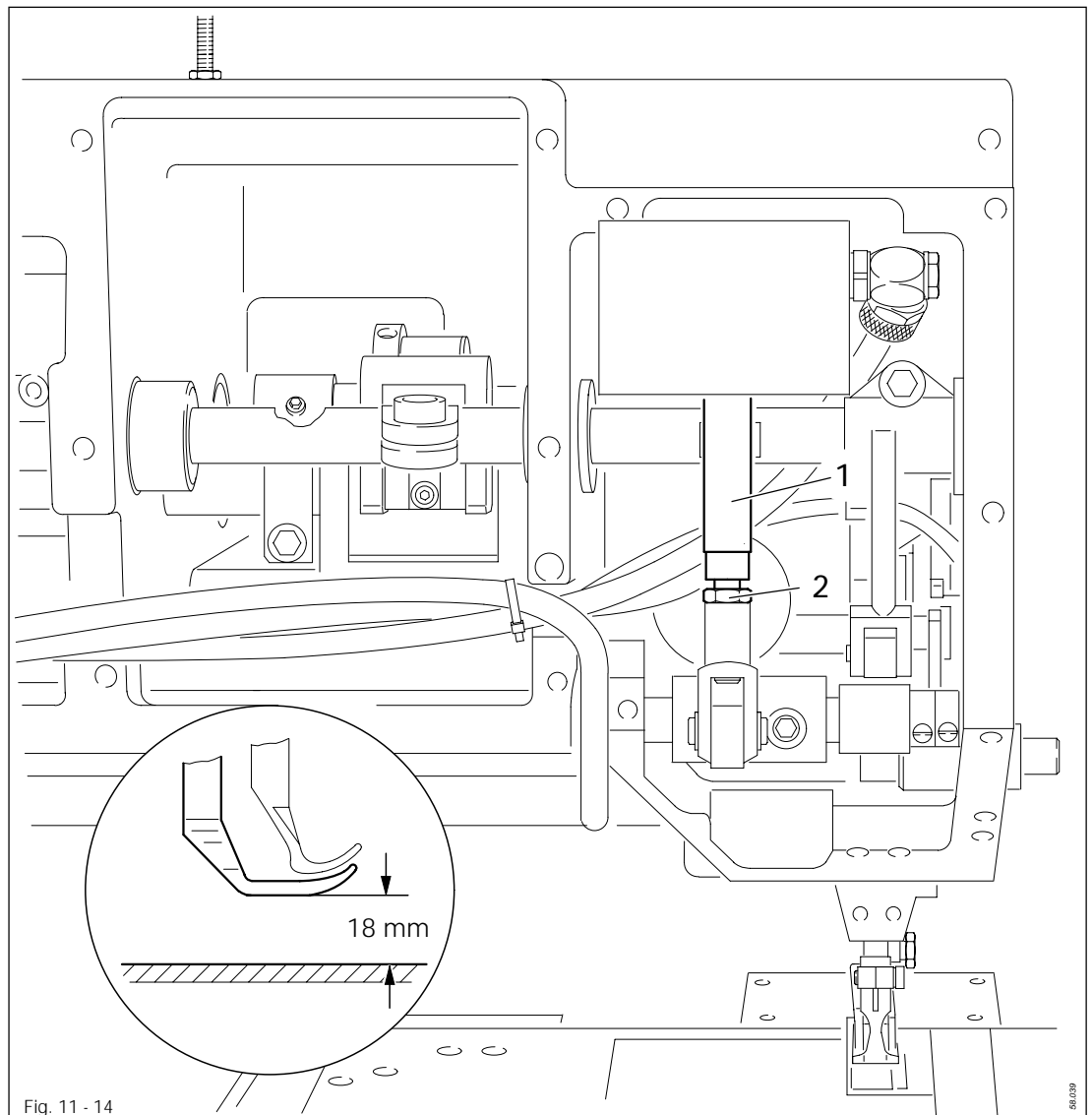

- Raise the lifting presser and lock it with fixing key 1.
- Turn plunger 1 (nut 2) according to Requirement.

11.04.15 Bobbin winder

Requirement

1. When the bobbin winder is engaged, the winding spindle must be driven reliably; when it is disengaged, friction wheel 5 must not rest on driving wheel 1.
2. The bobbin winder must wind evenly and switch itself off when the filled thread is about 1 mm from the edge of the bobbin.

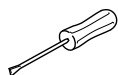
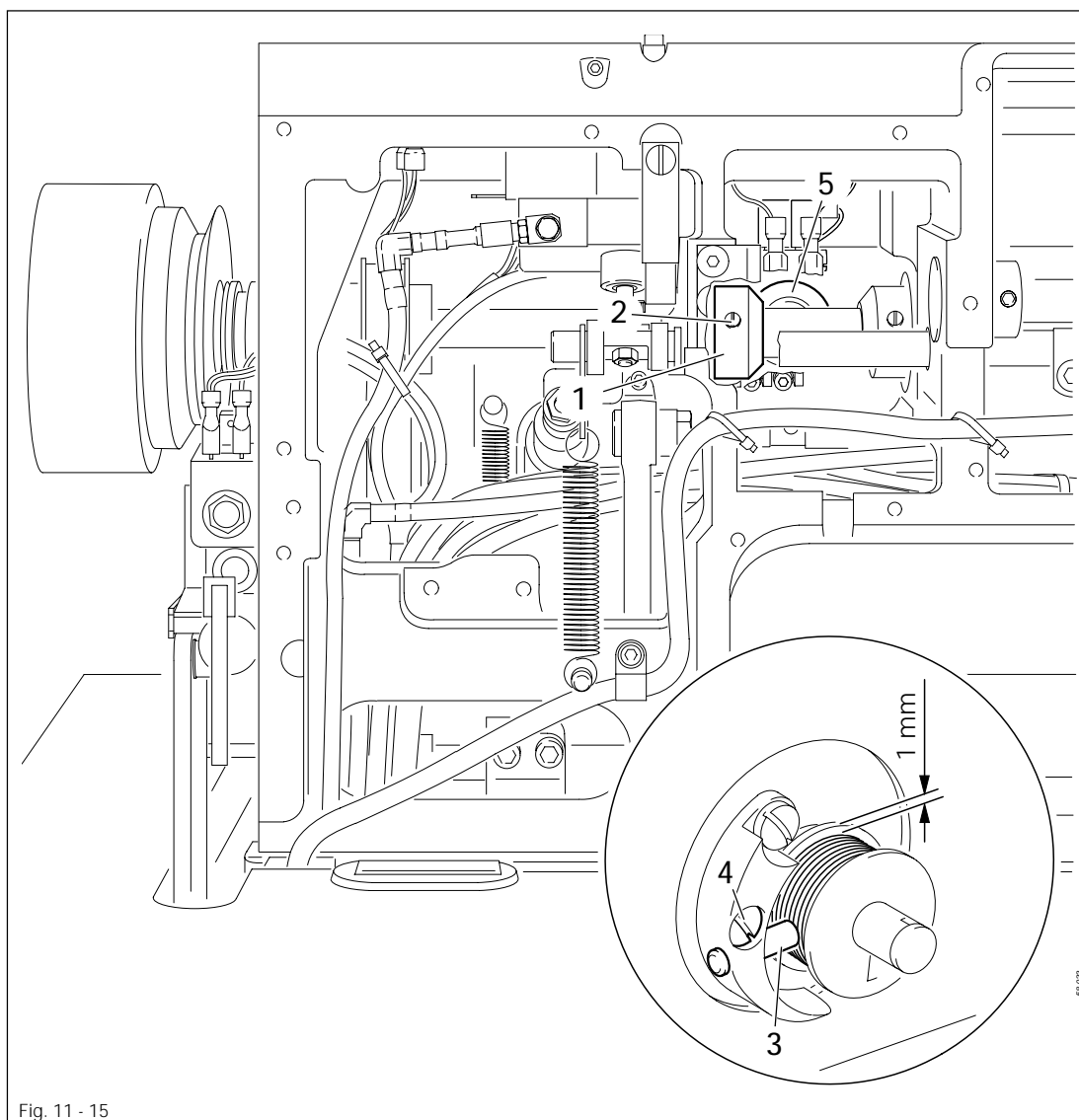

- Position drive wheel 1 (screw 2) according to Requirement 1.
- Position adjusting pin 3 (screw 4) according to Requirement 2.

11.04.16 Thread check spring and regulator on the PFAFF 1425

Requirement

1. The movement of thread check spring 7 must be completed when the needle point enters the material.
2. When the thread loop is opened to its largest amount while being passed around the sewing hook, thread check spring 7 must rise slightly from rest 1.

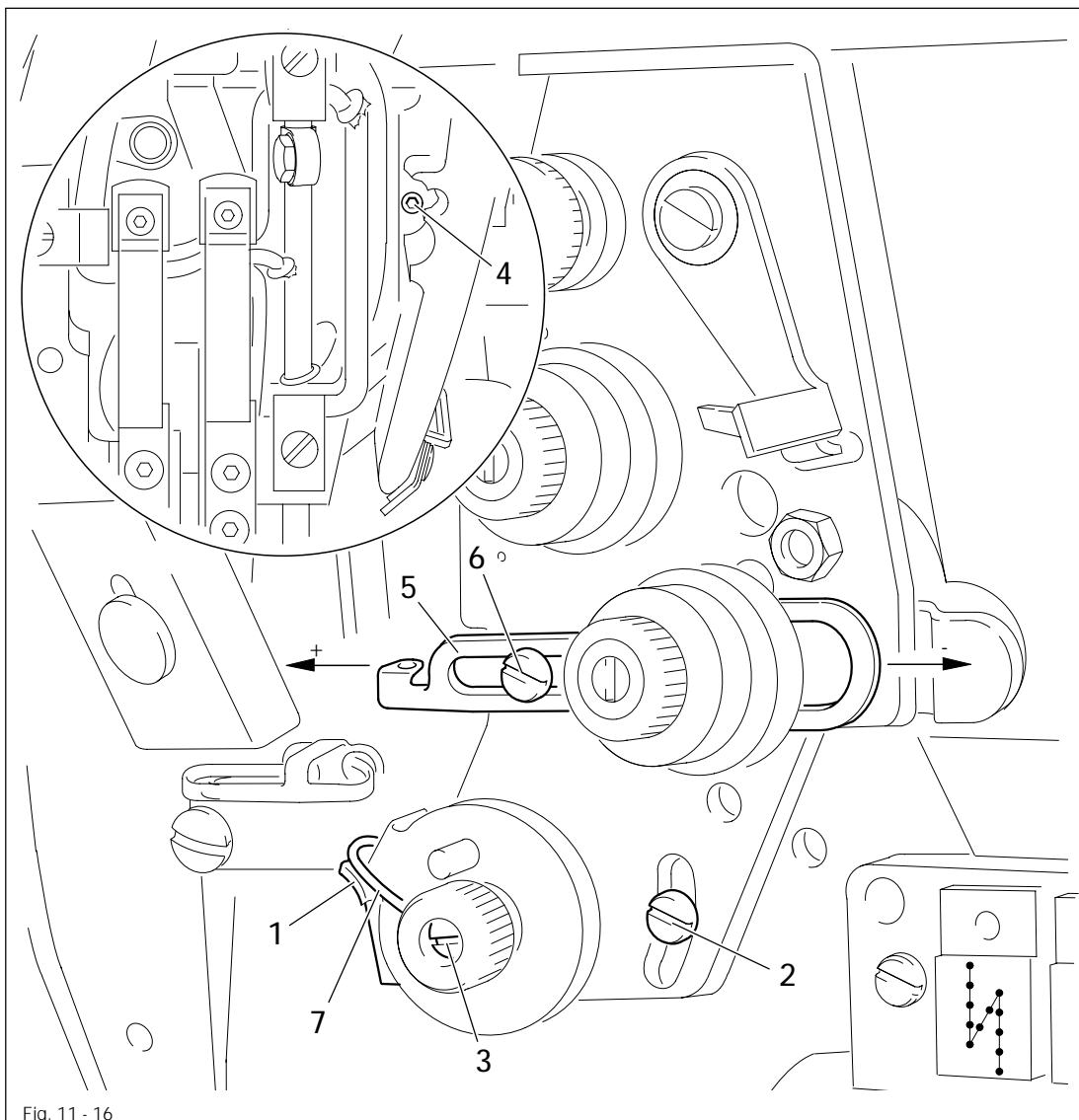
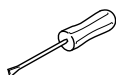

Fig. 11 - 16



- Position rest 1 (screw 2) according to Requirement 1.
- To adjust the spring tension, turn screw 3 (screw 4).
- Position thread regulator 5 (screw 6) according to Requirement 2.



For technical sewing reasons it may be necessary to deviate from the indicated spring stroke or spring tension.

Move thread regulator 5 (screw 6) to " + " (= more thread) or " - " (= less thread).

11.04.17 Thread check springs and regulators on the PFAFF 1426

Requirement

1. The movement of thread regulators 3 and 6 must be completed when the needle enters the material.
2. When the thread loop is opened to its largest amount while being passed around the sewing hook, thread check springs 3 and 6 must rise slightly from rests 1 and 9.

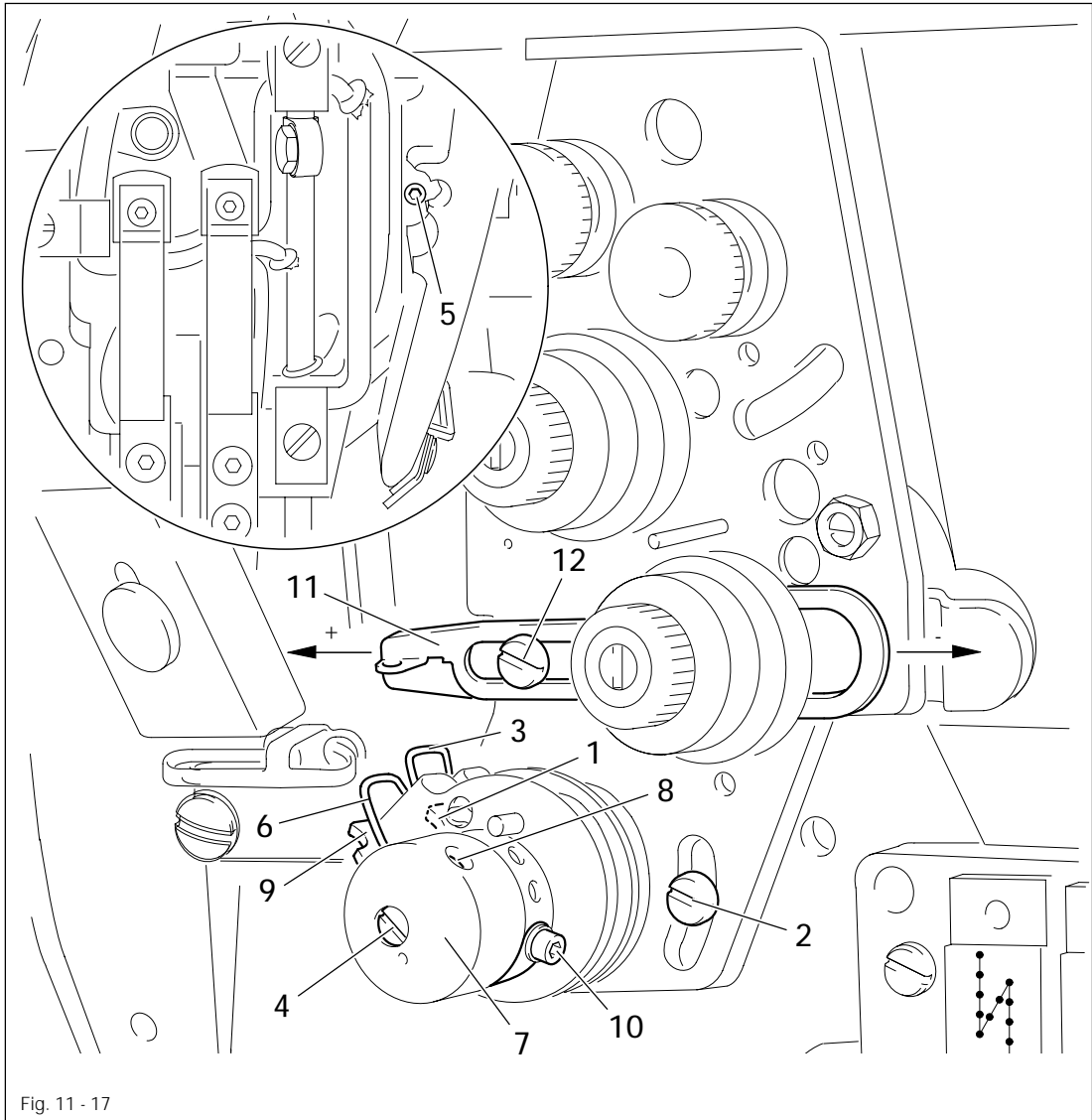
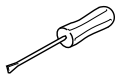

Fig. 11 - 17



- Position rest 1 (screw 2) according to **Requirement 1**.
- To adjust the tension of thread check spring 3, turn screw 4 (screw 5).
- To adjust the tension of thread check spring 6, turn sleeve 7 (screw 8).
- Position rest 9 (screw 10) according to **Requirement 1**. (If the adjustment range is too small, rest 9 can be screwed into another hole.)
- Position thread regulator 11 (screw 12) according to **Requirement 2**.



For technical sewing reasons it may be necessary to deviate from the indicated spring stroke or spring tension.

Move thread regulator 11 (screw 12) to " + " (= more thread) or " - " (= less thread).

11.04.18 Speed reduction when the stroke is increased

Requirement

1. With a 2.5 mm stroke the speed should be reduced to 3000 spm.
2. With a 4.5 mm stroke the speed should be reduced to 2200 spm.

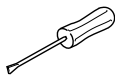
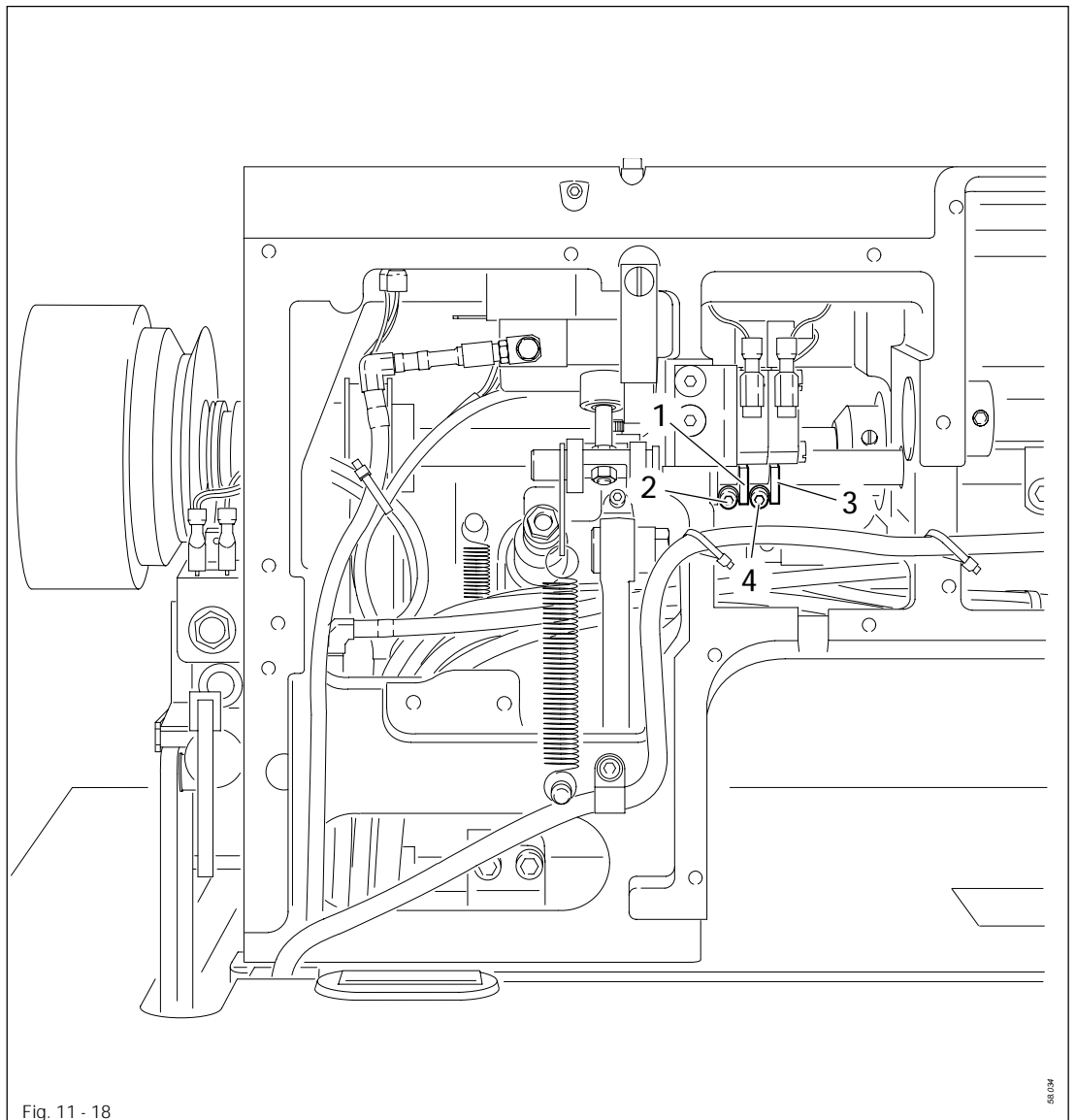

- Adjust trip 1 (screw 2) according to requirement 1.
- Adjust trip 3 (screw 4) according to requirement 2.



The switch position of both switches can be controlled on the operating panel (see Hardware test in the motor instruction manual).

11.04.19 Needle-thread tension release

Requirement

1. When stop 4 is actuated by hand there must be a clearance of at least 0.8 mm between tension discs 3.
2. When stop 4 is in its resting position the tension must be engaged.

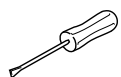
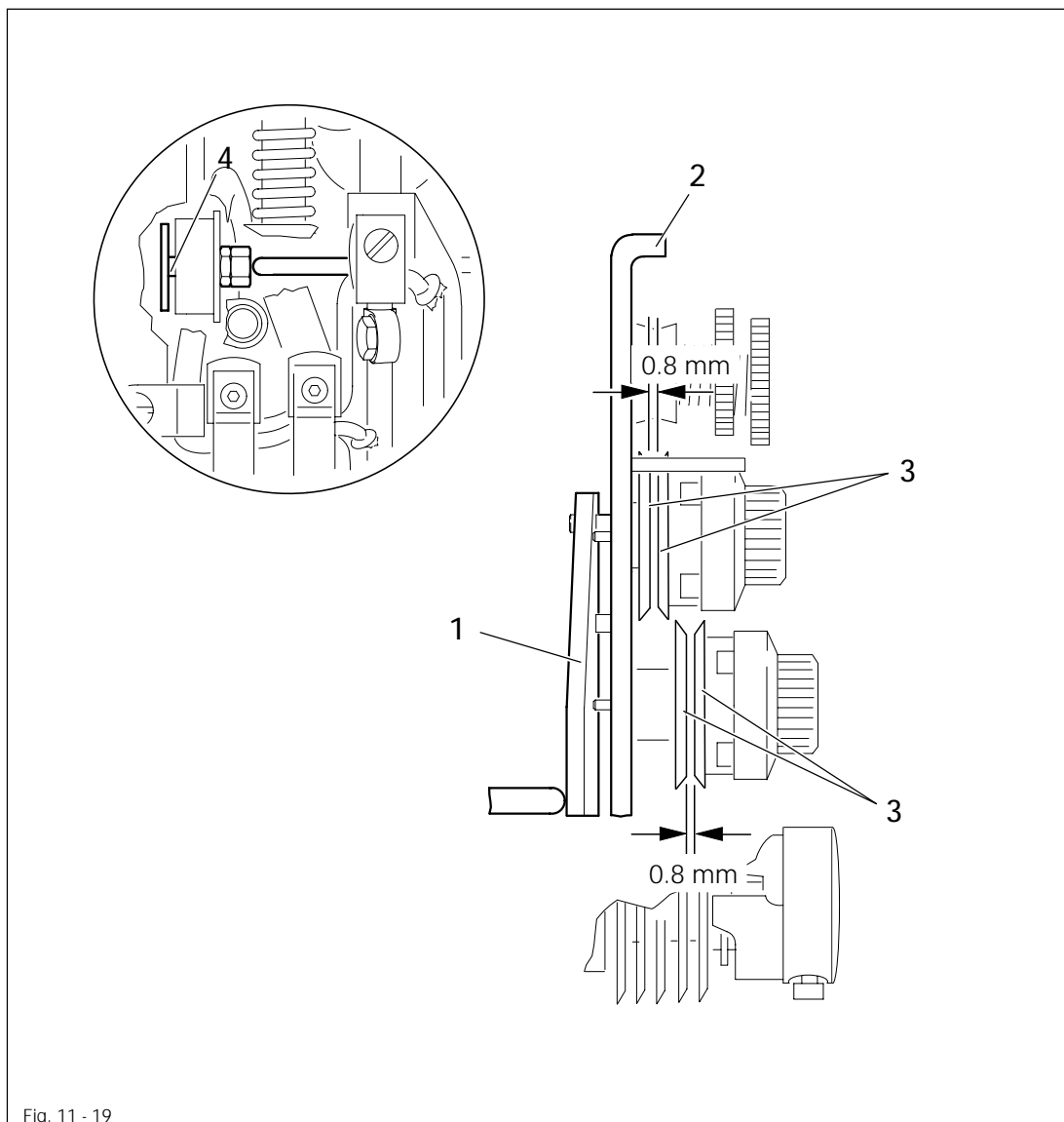

- Position pressure plate 1 behind tension mounting plate 2 according to Requirement.

11.04.20 Lubrication

Requirement

After a running time of ten seconds a thin film of oil must appear on a paper strip 1 held at the side of the sewing hook.

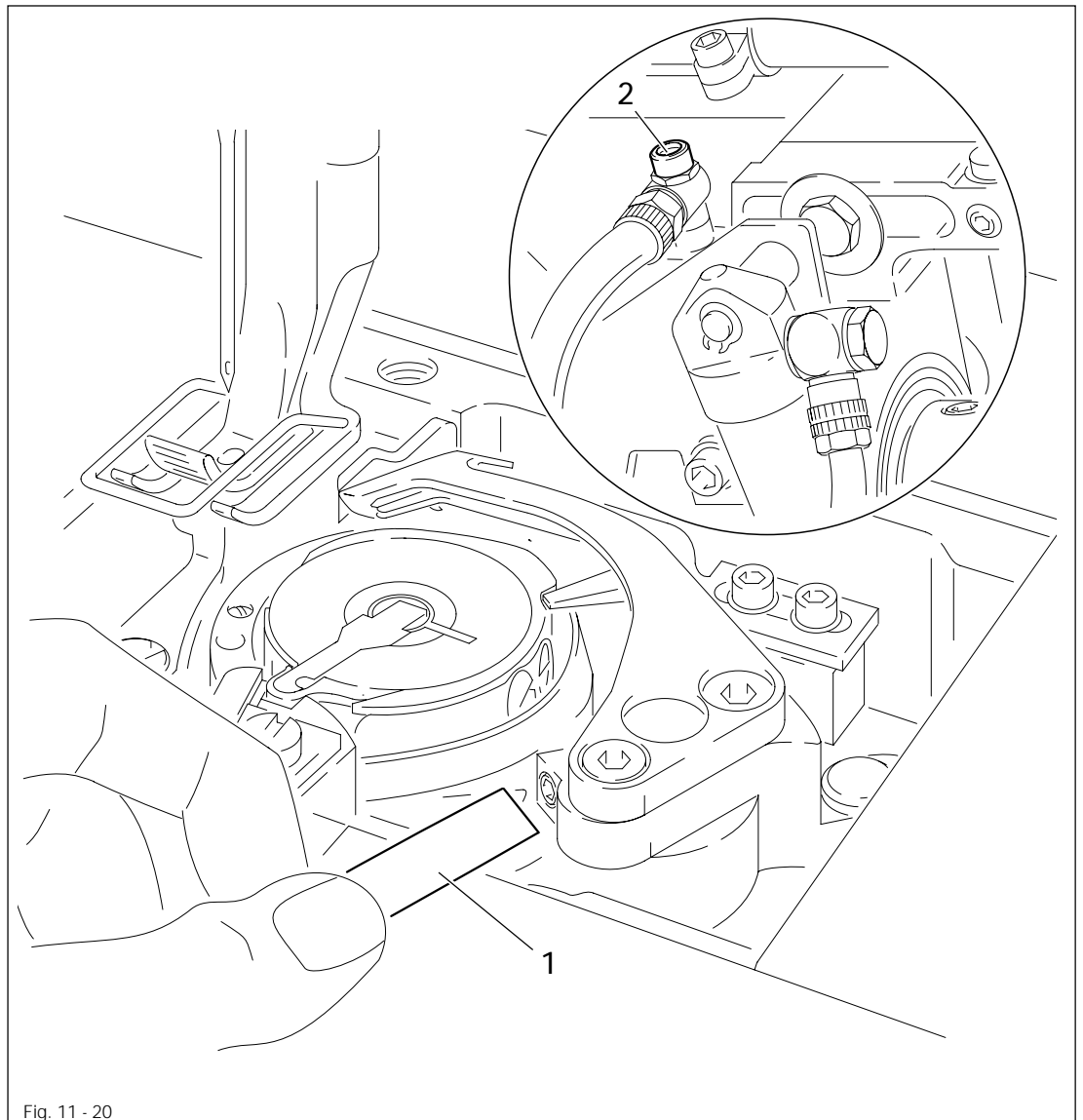
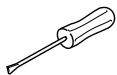

Fig. 11 - 20



- Check that machine has been filled with oil and that oil lines are free of air.
- Run the machine for 2 to 3 mins.



Do not put your hands into the sewing area while the machine is running!
Danger of injury by moving parts!

- With the machine running, hold a paper strip 1 at the hook and check according to Requirement.
- If necessary, regulate oil on screw 2.

11.04.21 Re-engaging the slip-clutch



Clutch 1 is adjusted at the works. In the case of a thread jamming, clutch 1 will disengage, in order to avoid damage to the hooks. The following describes how to re-engage clutch 1.

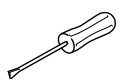
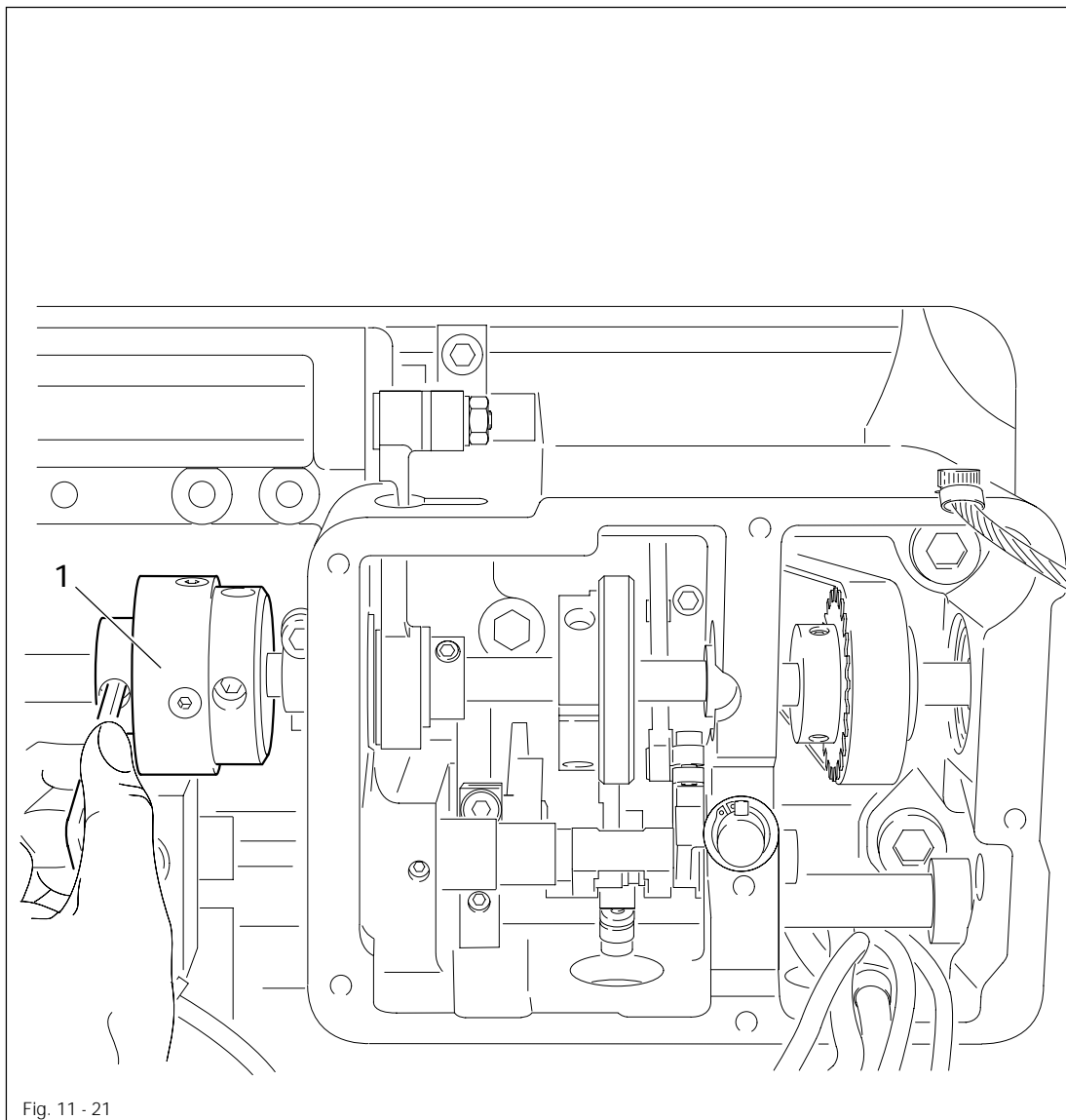

- Remedy jammed thread fault.
- Hold clutch 1 firmly, as shown in Fig. 11-21a, and turn the balance wheel until clutch 1 re-engages.

11.05 Adjusting the edge trimmer -731/02

11.05.01 Neutral position of knife

Requirement

When the edge trimmer is disengaged, the knife must not move when the balance wheel is turned.

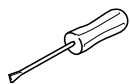
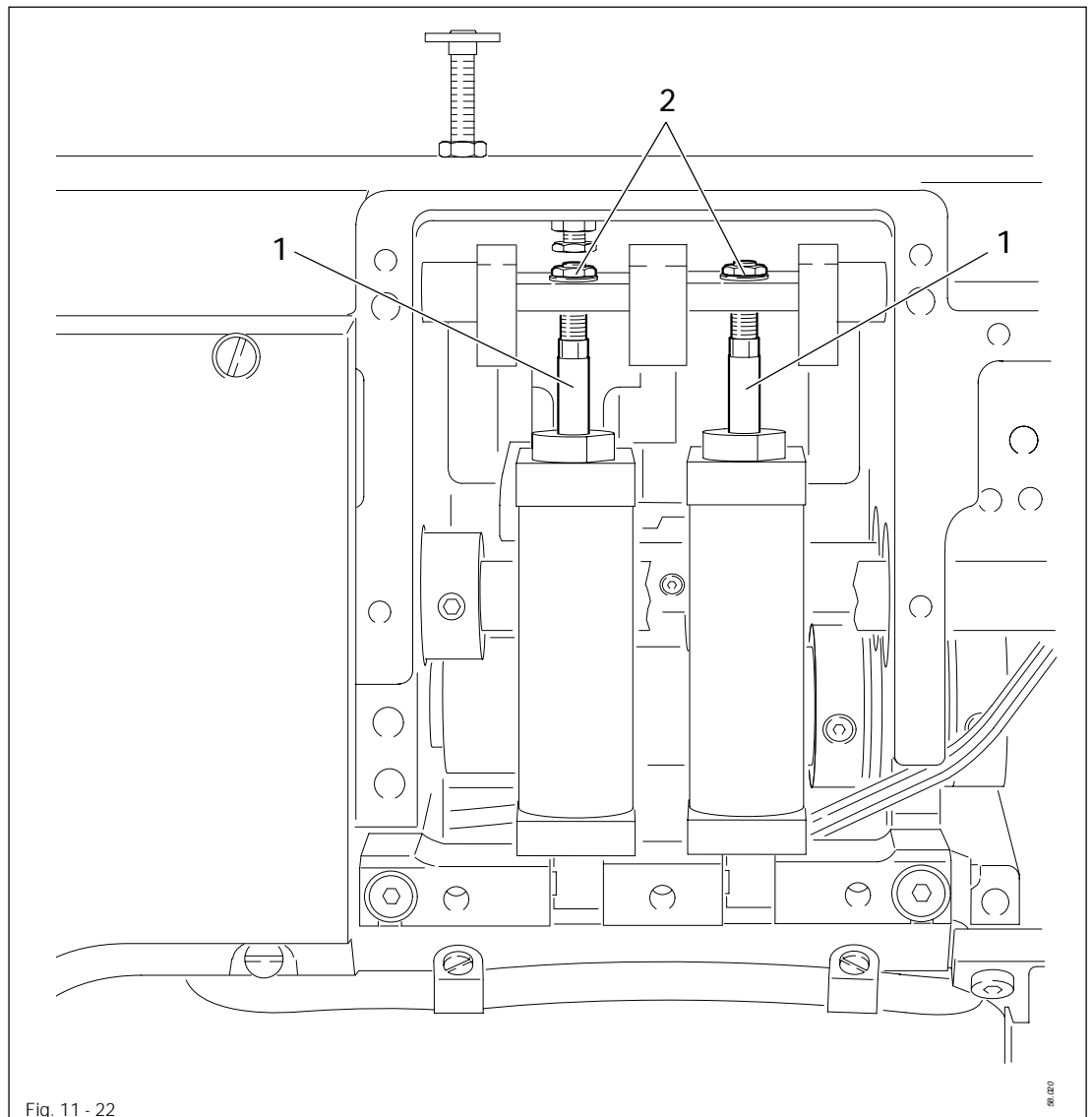

- Turn on compressed air and disengage edge trimmer.
- Turn cylinder plunger 1 (nut 2) according to Requirement.

Adjustment

11.05.02 Knife stroke

Requirement

The maximum knife stroke must be 9 mm

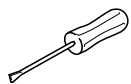
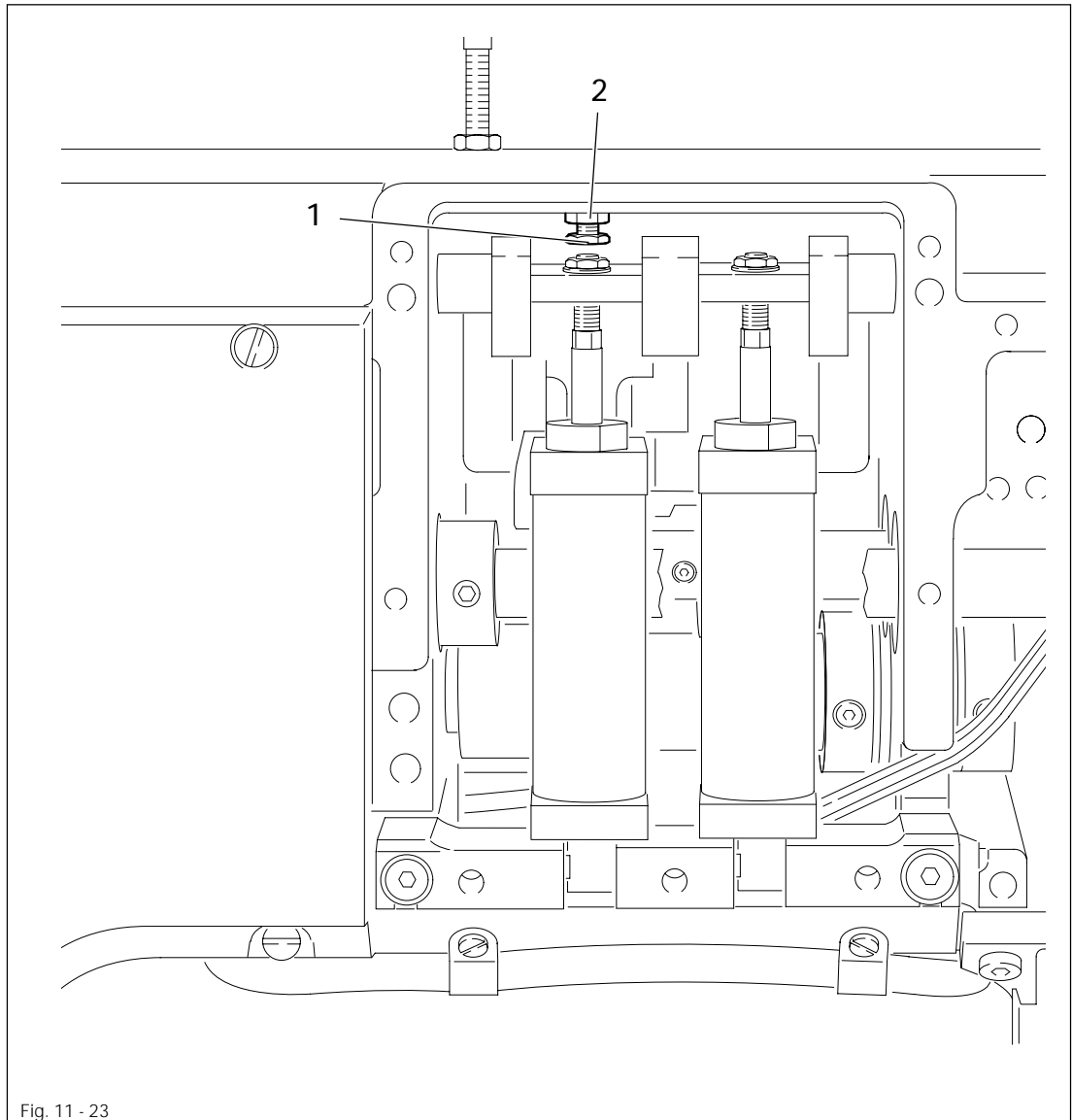

- Engage edge trimmer.
- Adjust screw 1 (nut 2) according to Requirement.

11.05.03 Cutting stroke

Requirement

With the edge trimmer engaged and the needle bar at b.d.c. the knife must be at t.d.c.

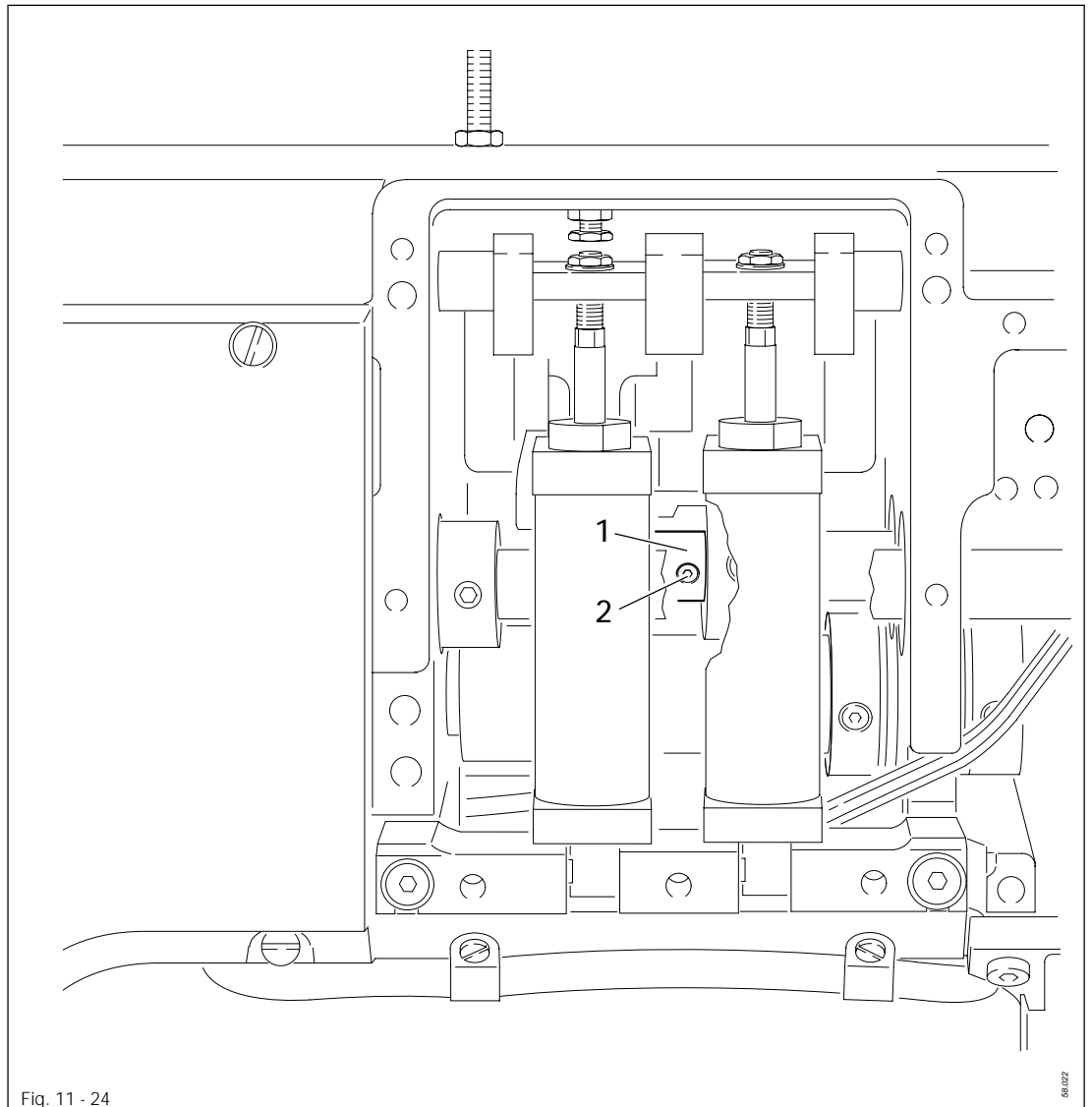
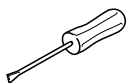

Fig. 11 - 24



- Engage edge trimmer and set needle bar at b.d.c.
- Turn eccentric 1 (two screws 2) according to Requirement.

Adjustment

11.05.04 Actuating lever

Requirement

With the edge trimmer disengaged there must be a clearance of **0.5 mm** between base 3 and the housing.

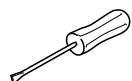
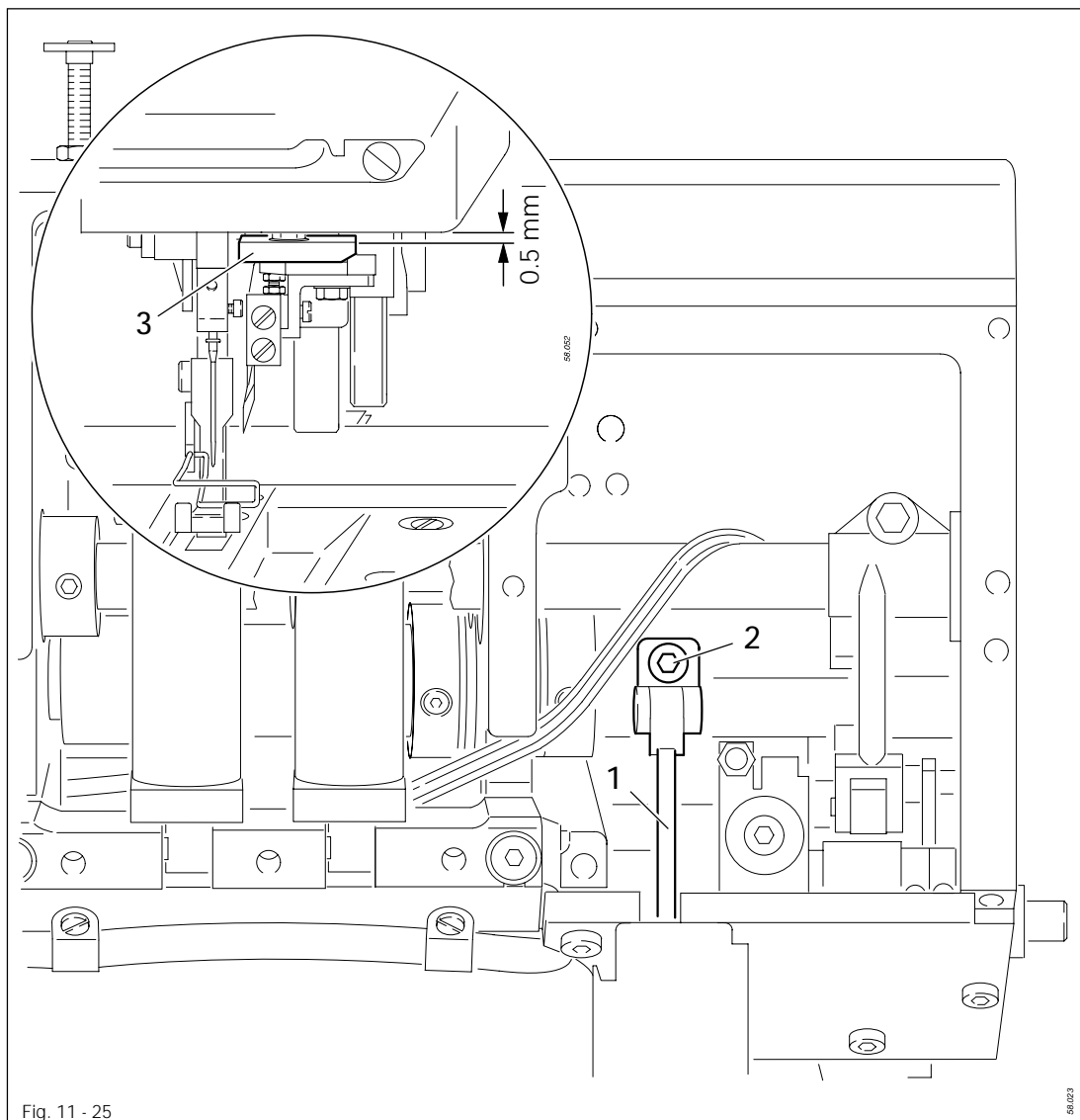

- Re-position lever 1 (screw 2) according to Requirement.

11.05.05 Knife height

Requirement

When the knife is at b.d.c. the front of the knife cutting edge must be about 0.5 mm under the top edge of the stationary knife.

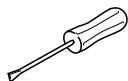
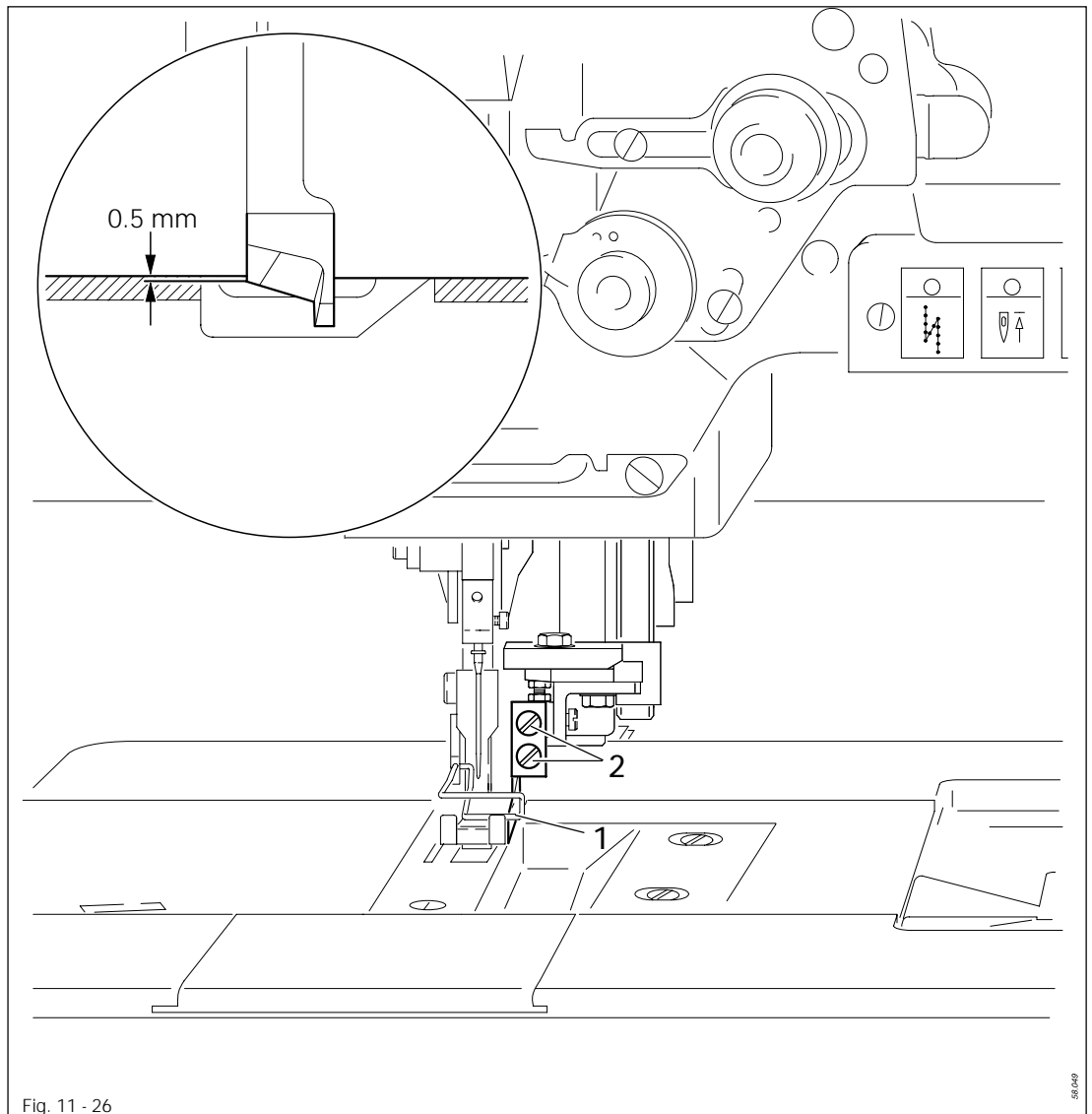

- Engage edge trimmer and set knife at its lowest position.
- Re-position knife 1 (screws 2) according to **Requirement**.

Adjustment

11.05.06 Knife position in sewing direction

Requirement

With the needle bar at b.d.c. the middle of the knife must be at "needle centre."

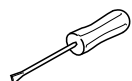
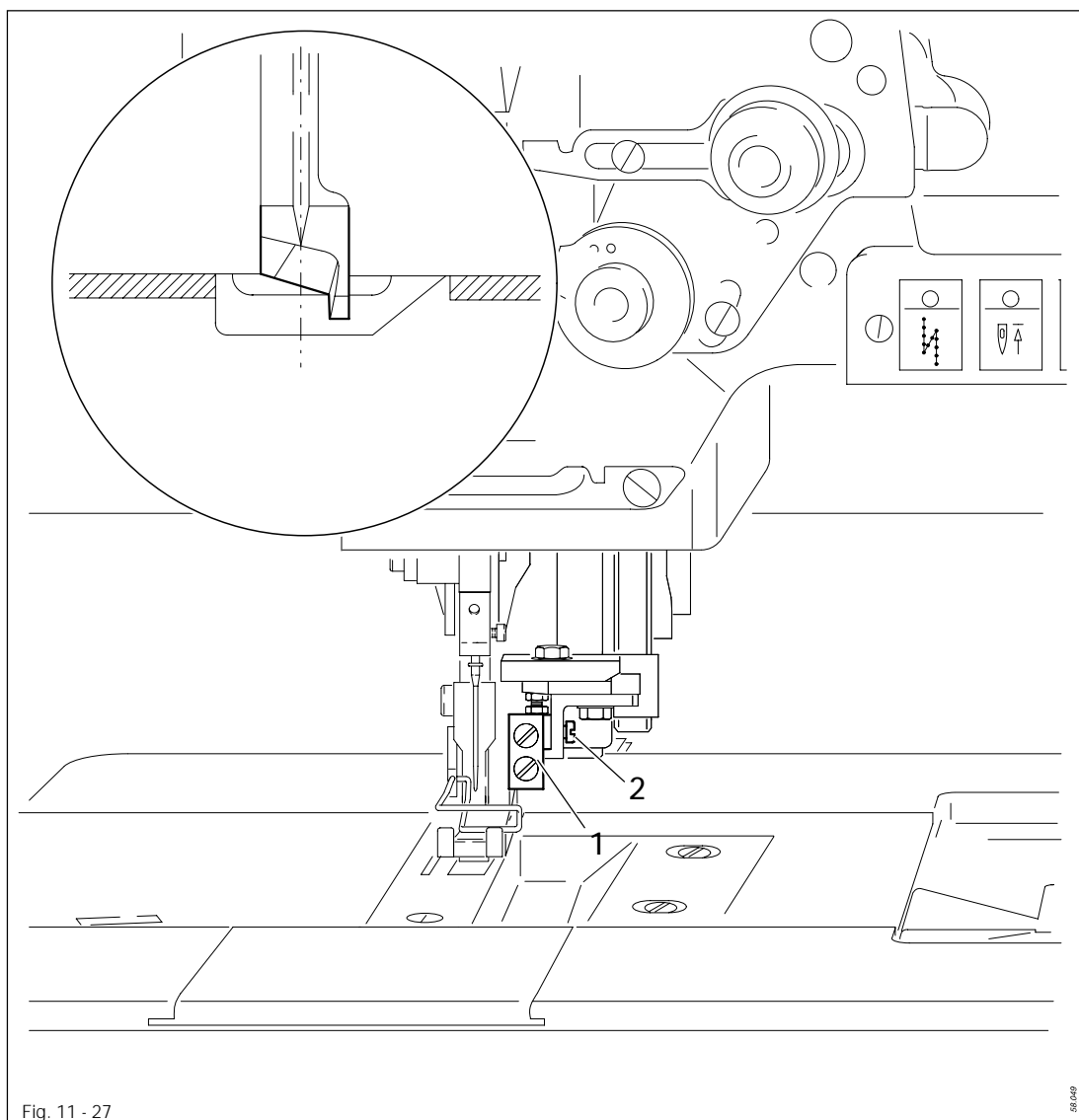

- Re-position knife mounting 1 (screw 2) according to Requirement.

11.05.07 Knife position crosswise to sewing direction

Requirement

1. The knife must rest with light pressure against stationary knife 3.
2. The knife must be at a slight angle to stationary knife 3 (shear action of approx. 2°).

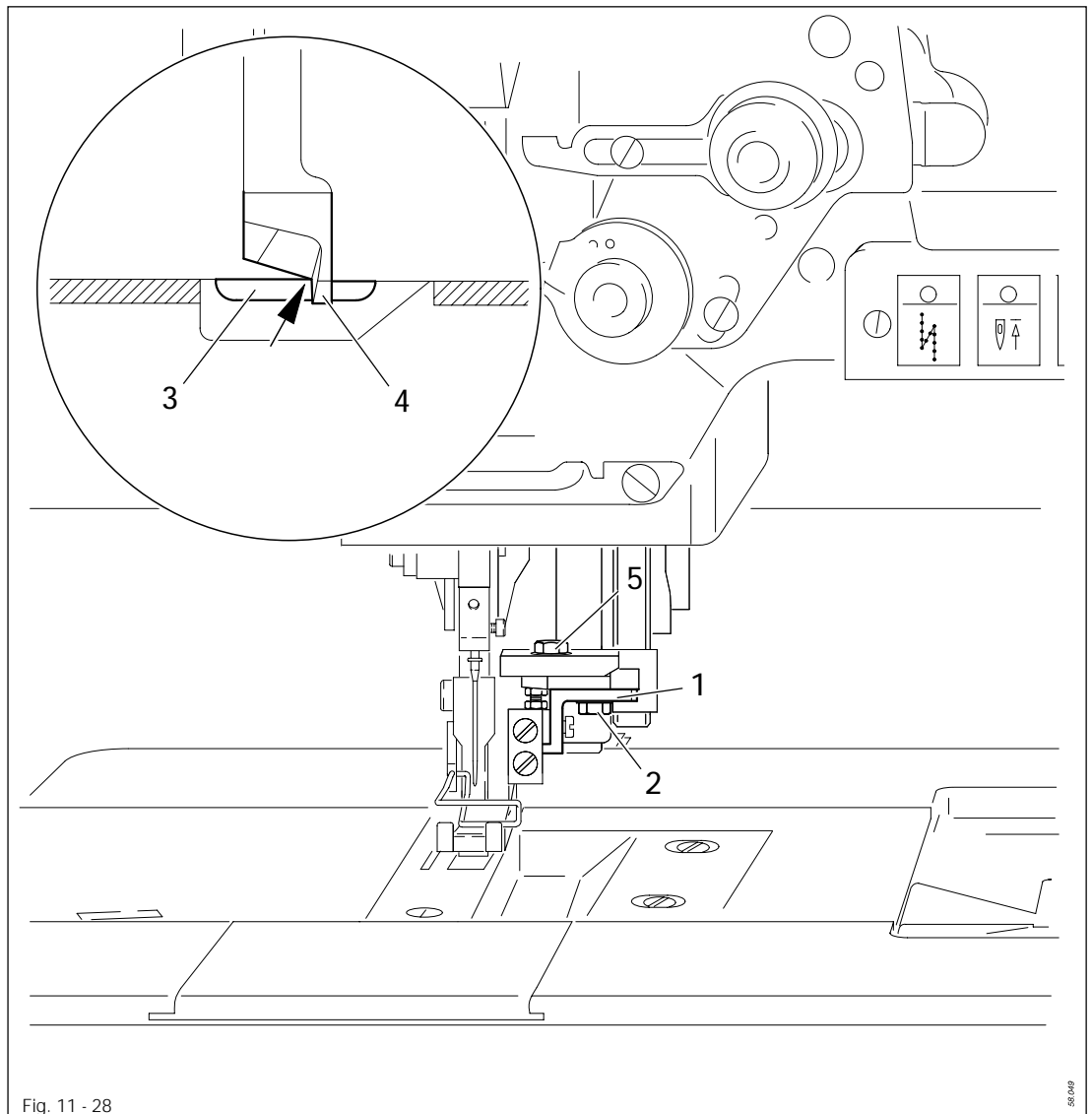
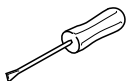

Fig. 11 - 28



- Adjust knife mounting 1 (screw 2) according to **Requirement 2**.
- Engage edge trimmer.
- Turn balance wheel to set rear of knife cutting edge in line with top edge of stationary knife 3 (see arrow).
- Set knife spur 4 (screw 5) against stationary knife 3 without pressure.



During the cutting action the slight angular off-set of the knife to stationary knife 3 causes a slight pressure (**Requirement 1**).

- Set knife at its lowest position; there must then be a small clearance between back edge of knife and stationary knife 3 (shear action).
- Repeat adjustment if necessary.

11.06 Adjusting the thread trimmer 900/81

11.06.01 Resting position of roller lever/radial position of control cam

Requirement

1. When cylinder plunger 1 is retracted there must be a clearance of **0.1 mm** between outer edge of control cam 6 and the roller of lever 5.
2. When cylinder plunger 1 is retracted and the take-up lever is at t.d.c., control cam 6 must just move roller lever 5 to its resting position

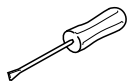
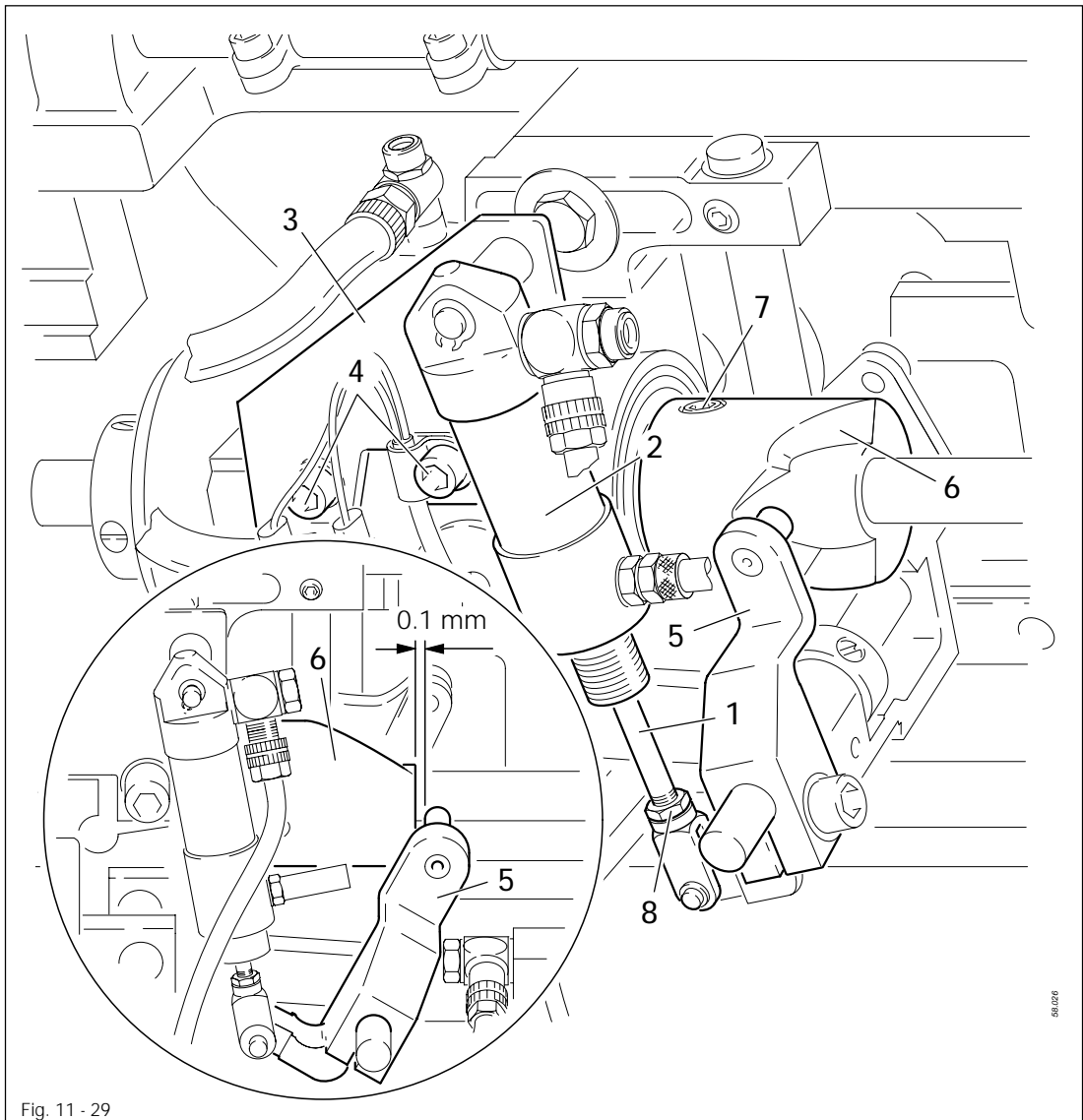

- Fully retract plunger 1 into cylinder 2.
- Re-position cylinder mounting 3 (screws 4) according to Requirement 1.
- Push roller lever 5 into control cam 6.
- Set take-up lever at t.d.c. and turn control 6 (screws 7) according to Requirement 2.



On cylinder plunger 1, about 1 mm of thread must protrude above locknut 8.

11.06.02 Thread-catcher height

Requirement

The lower edge of thread catcher 3 must clear bobbin 4 case by about 0.8 mm.

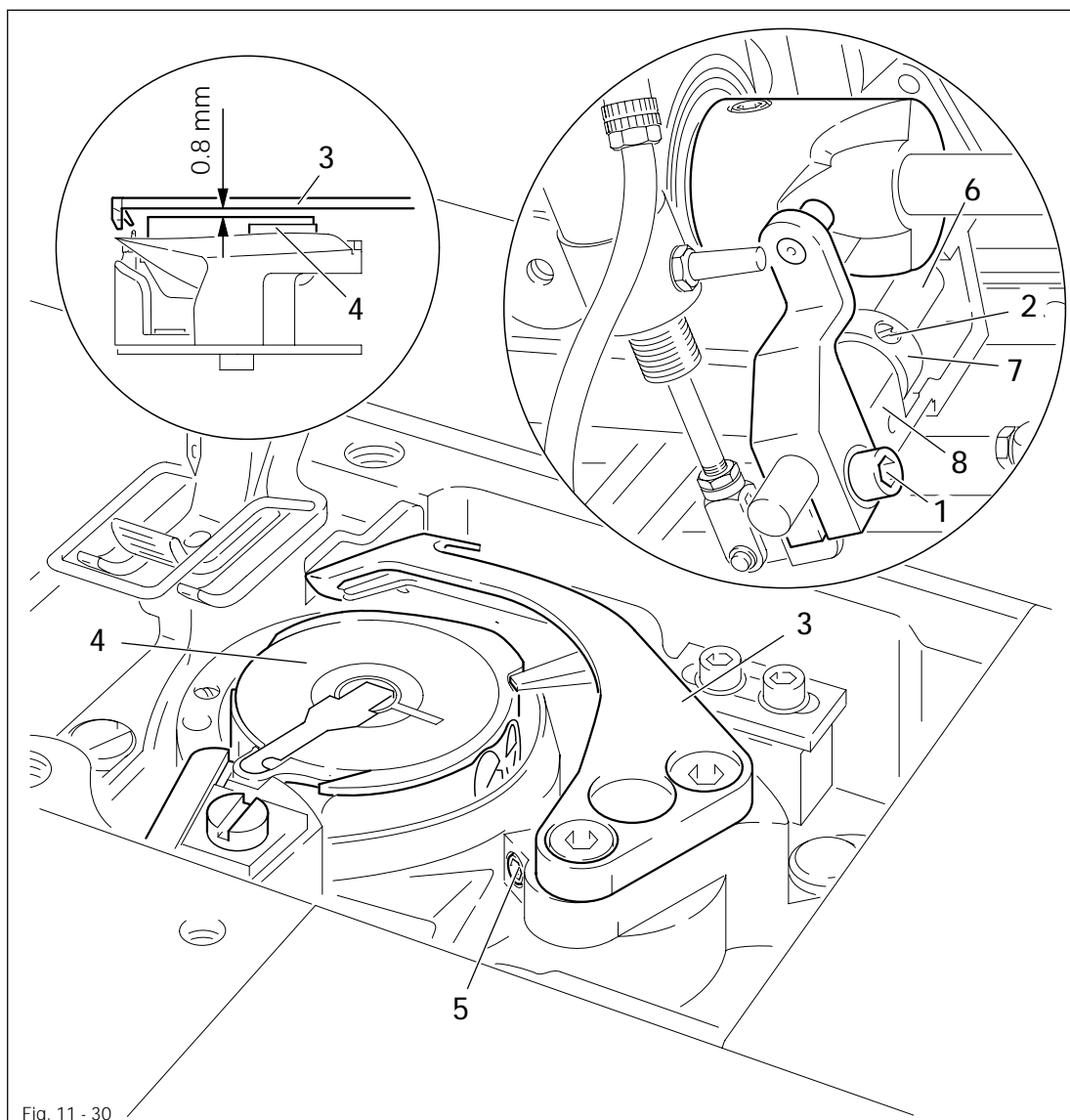
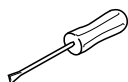

Fig. 11 - 30



- Loosen screws 1 and 2.
- Set thread catcher 3 above bobbin case 4.
- Re-position thread catcher 3 (screw 5) according to **Requirement**.
- Balance out the vertical play of shaft 6, set fixing collar 7 against bearing housing 8 and tighten screw 2.



For further adjustments leave screw 1 untightened.

Adjustment

11.06.03 Thread catcher position

Requirement

When the thread catcher is in its resting position, the edges of thread catcher 4 and knife 5 must be flush (see arrow).

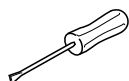
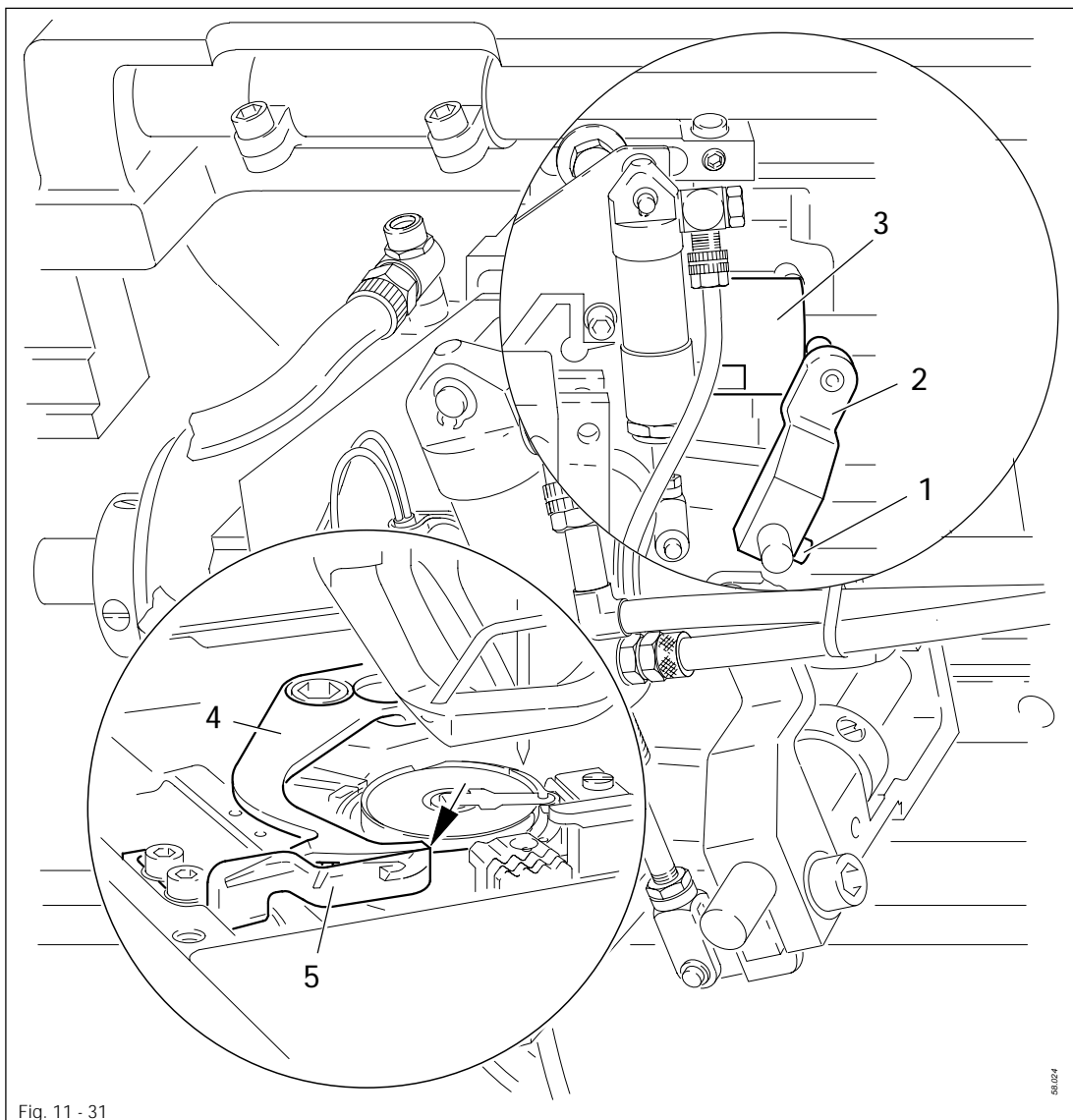

- Set needle bar at b.d.c. and push roller lever 2 against control cam 3.
- Turn thread catcher 4 according to **Requirement**.
- Tighten screw 1.

11.06.04 Knife height

Requirement

With the thread trimmer in its resting position the edges of thread catcher 3 and knife 1 must be flush (see arrow).

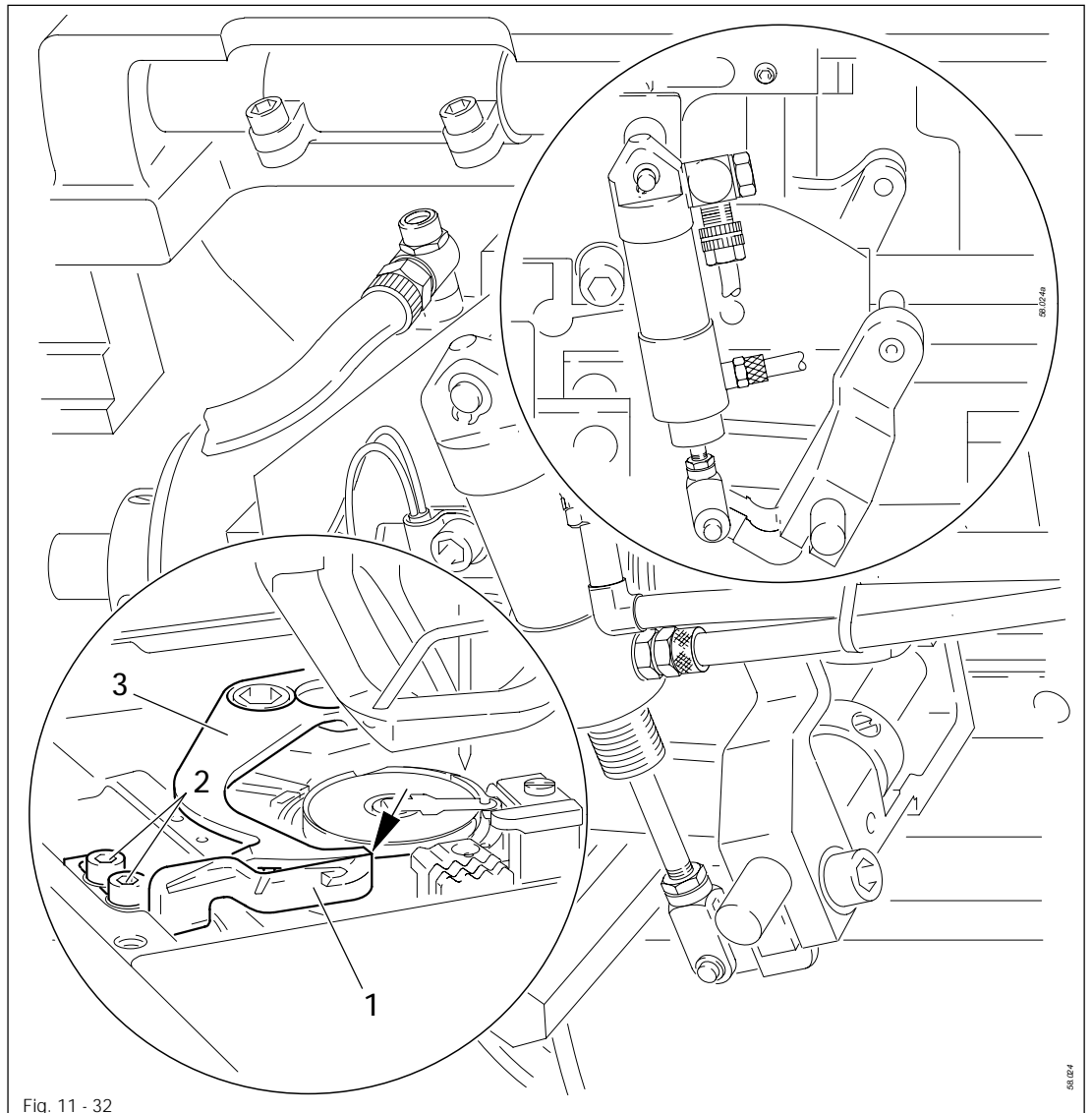
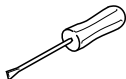

Fig. 11 - 32



- Check knife height according to Requirement.



To adapt the height of knife 1, remove it (screws 2) and fit shims (part No. 91-141 402-05) according to Requirement .

11.06.05 Knife pressure

Requirement

When the front edge of thread catcher 3 has passed the cutting edge by half, knife 4 must rest with light pressure on the edge of the catcher.

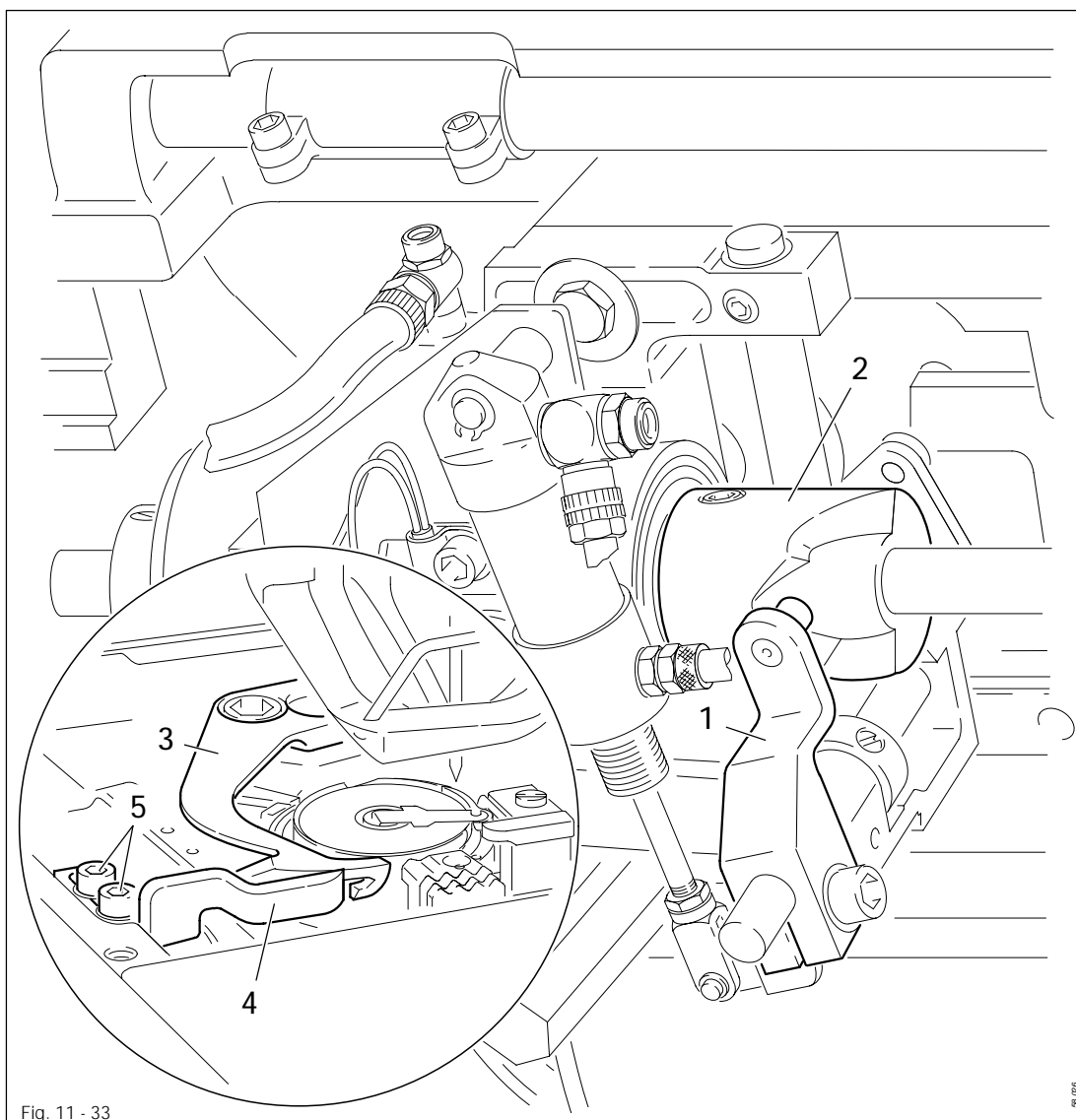
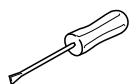

Fig. 11 - 33



- Set take-up lever at b.d.c. and push roller lever 1 into control cam 2.
- Turn balance wheel until front edge of catcher 3 has passed cutting edge of knife 4 by half.
- Re-position knife 4 (screws 5) according to **Requirement**.



After adjustment, check again according to Chapter 11.06.03 Thread catcher position.

11.06.06 Bobbin-thread retaining spring

Requirement

Retaining spring 1 must

1. not be deflected during the thread catcher movement,
2. reliably retain bobbin thread 4 after cutting, and
3. not hinder removal and replacment of the bobbin case.

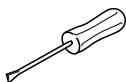
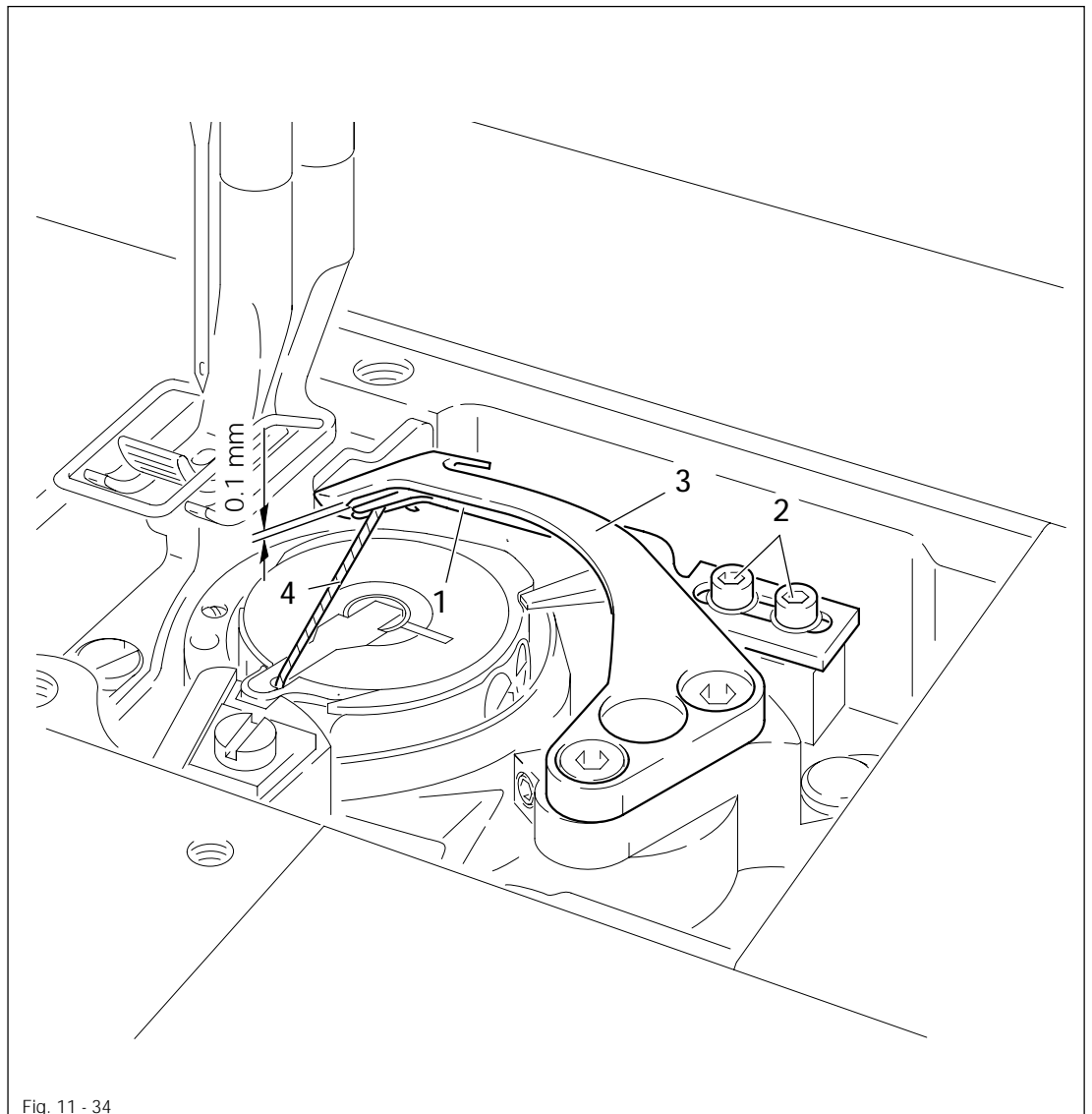

- Set thread trimmer at its resting position.
- Position retaining spring 1 (screws 2) so that the retaining lips are as close as possible to the inside wall and to the front edge of thread catcher 3.
- Bend retaining spring 1 to set its height so that there is a clearance of about 0.1 mm between top side of retaining spring 1 and thread catcher 3.

Adjustment

11.06.07 Thread catcher transmission crank (only on the PFAFF 1426)

Requirement

With the thread trimmer in its resting position the bearing points of roller 3, roller lever 4 and ball-joint 5 must be aligned.

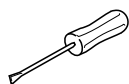
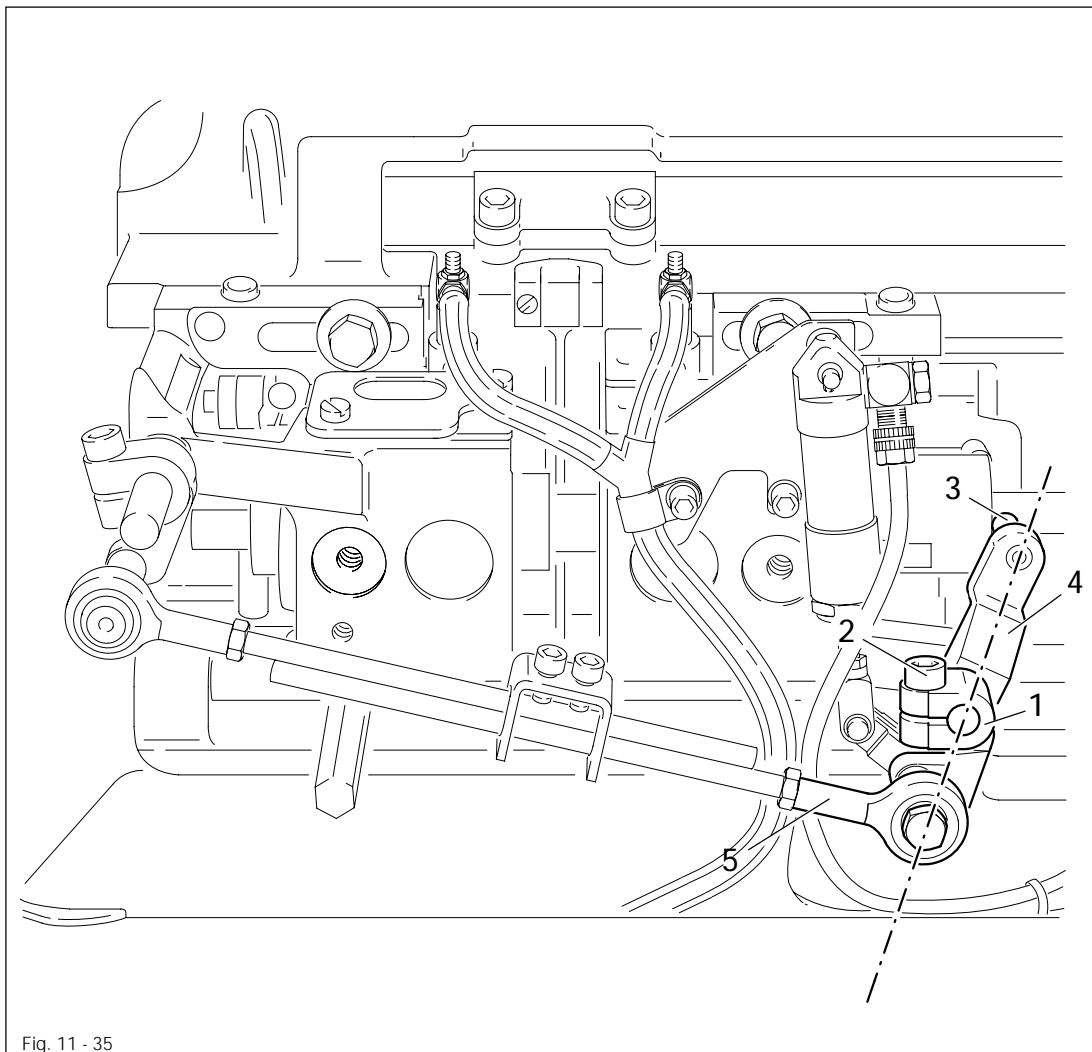

- Set thread trimmer at resting position.
- Turn transmission crank 1 (screw 2) according to Requirement.

11.06.08 Transmission linkage (only on the PFAFF 1426)

Requirement

With the thread trimmer in its resting position, transmission cranks 3 and 4 must stand parallel with each other.

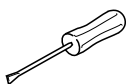
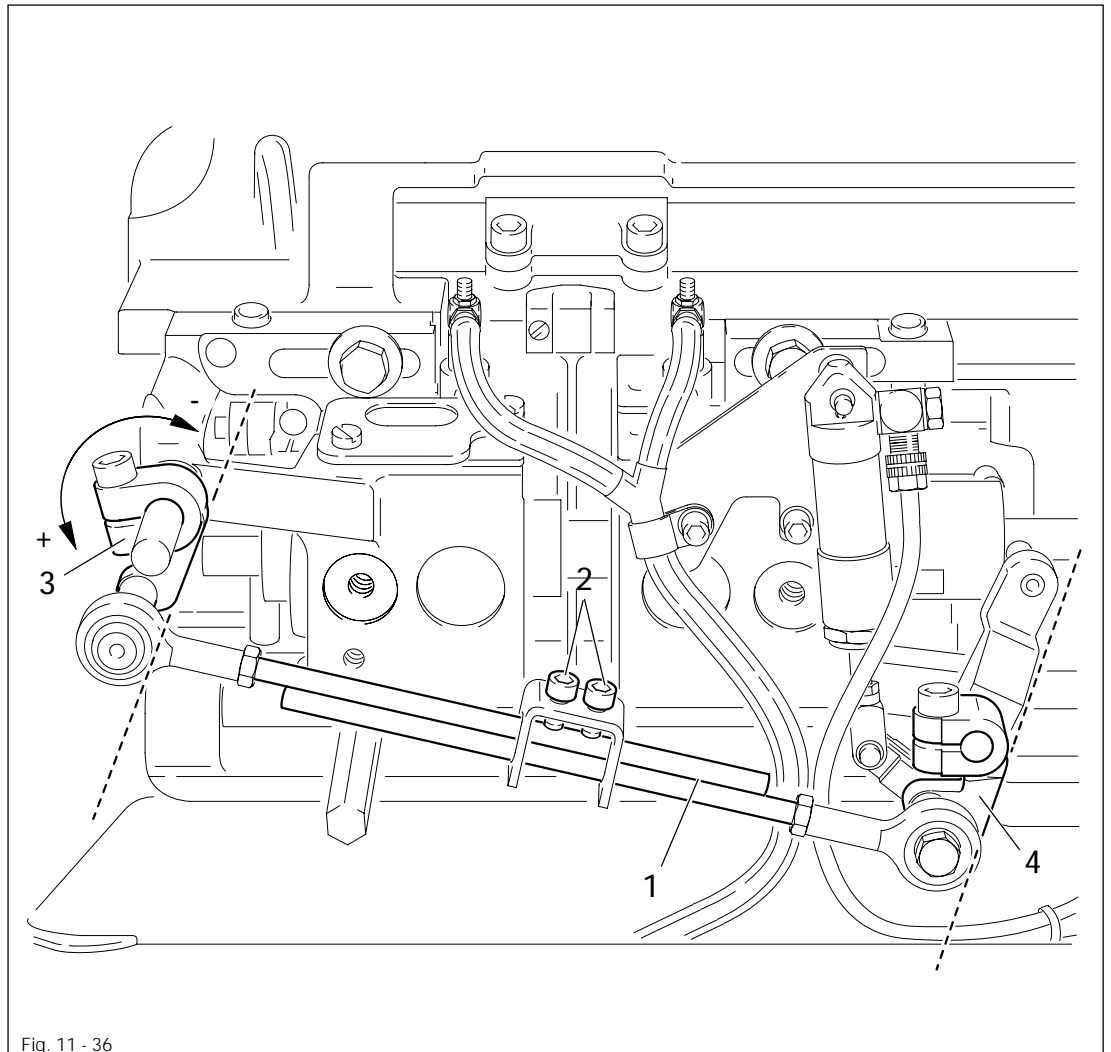

- Set the thread trimmer at its resting position.
- Adjust transmission linkage 1 (screws 2) according to Requirement.



If problems occur in thread catching on the left sewing hook, the catcher stroke can be increased (+) or decreased (-) by turning transmission crank 3.

11.06.09 Manual cutting test

Requirement

1. When thread catcher 1 is on its forward stroke, it must not carry bobbin thread 3 forward too.
2. When thread catcher 1 is in its front position, the bobbin thread 3 must be positioned in the middle of the marked area (see arrow).
3. After the trimming action, both needle- and bobbin thread must be perfectly cut, and bobbin thread 3 retained.

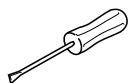
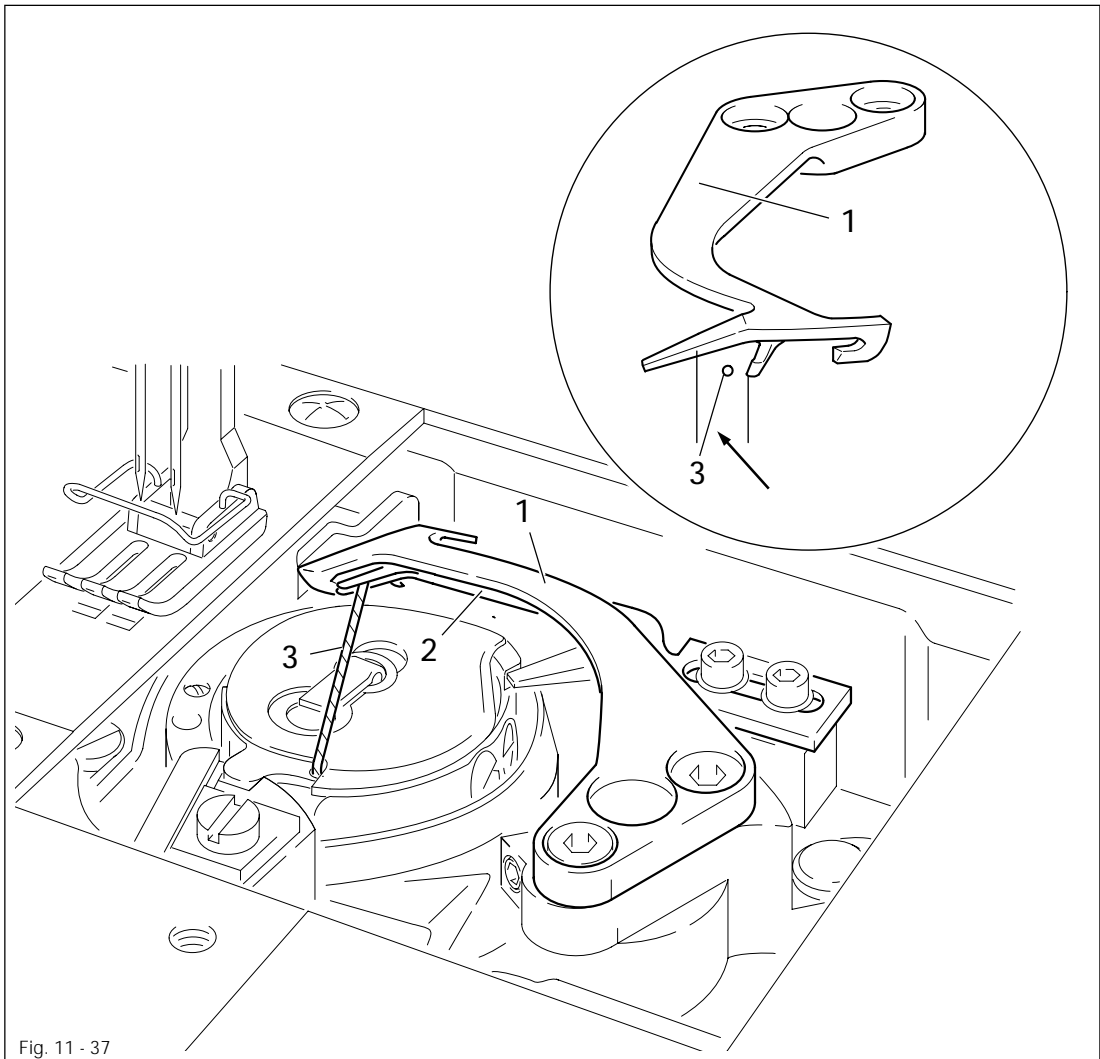

- Sew a few stitches.
- Turn off the on/off switch.
- Carry out cutting test manually.
- Check Requirement 1 and readjust thread catcher 1 according to Chapter 11.06.02 Thread-catcher height if necessary.
- Check Requirement 2 and readjust thread catcher 1 according to Chapter 11.06.03 Thread-catcher position if necessary.
- Check Requirement 3 and readjust bobbin-thread retaining spring 2 according to Chapter 11.06.06 Bobbin-thread retaining spring if necessary.

11.07 Adjusting the thread trimmer 900/82

11.07.01 Resting position of the roller lever/Preliminary adjustment of the radial position of the control cam

Requirement

1. When the cylinder plunger 1 is retracted, there must be a clearance of **0.1 mm** between the outer edge of control cam 6 and the roller of lever 5.
2. When the take-up lever is at TDC, the control cam 6 must have moved roller lever 5 to its cutting position.

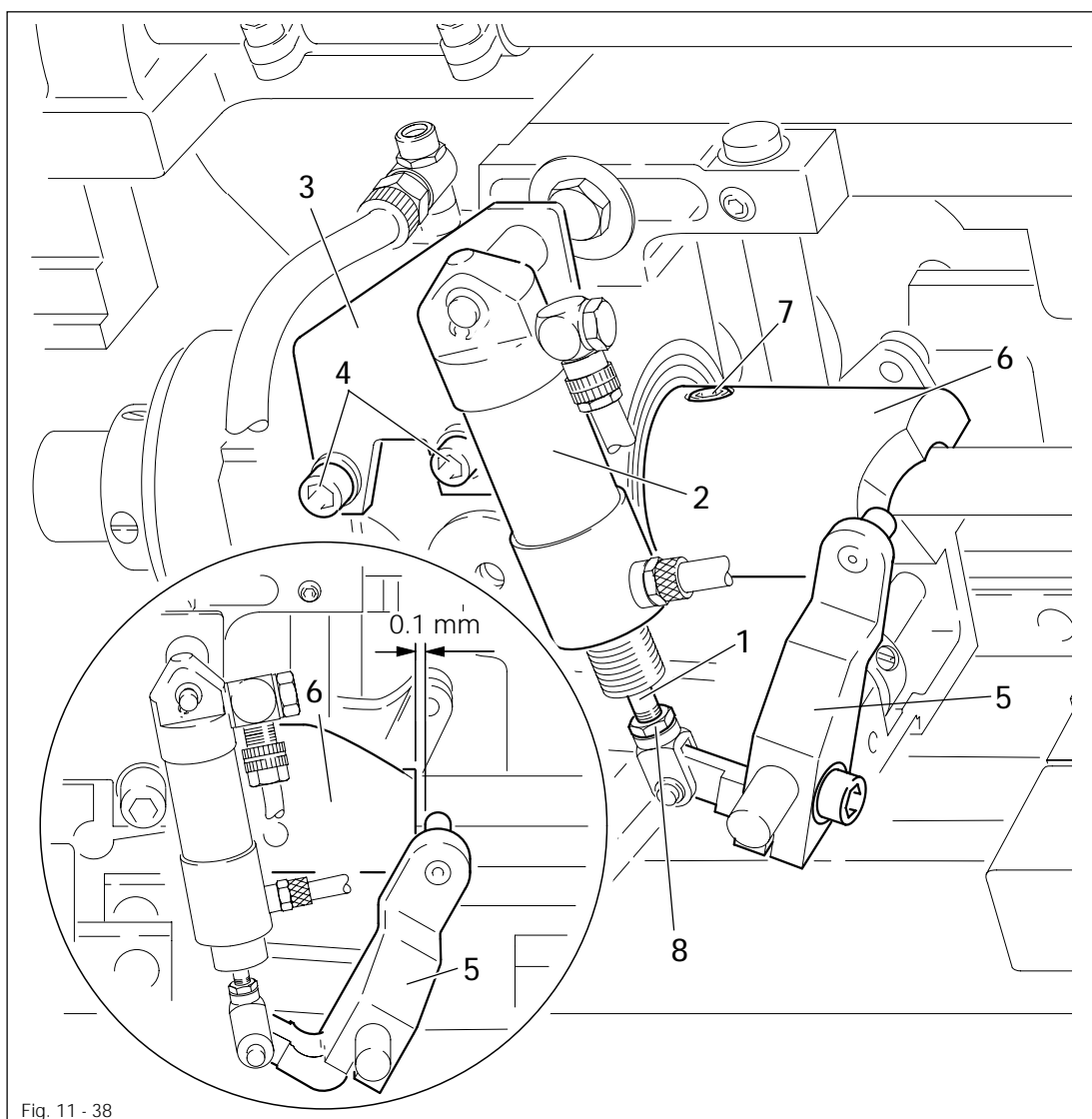
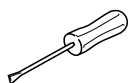

Fig. 11 - 38



- Fully retract plunger 1 into cylinder 2.
- Re-position cylinder mounting 3 (screws 4) according to Requirement 1.
- Push roller lever 5 into control cam 6.
- Set take-up lever at TDC.
- Turn control cam 6 (screws 7) according to Requirement 2.



On cylinder plunger 1 about 1 mm thread must protrude above locknut 8.

11.07.02 Thread catcher and knife height

Requirement

1. There should be a clearance of **0.6 mm** between the lower edge of the thread catcher 1 and the bobbin case 2.
2. When the thread trimmer is in its resting position the upper edges of knife 3 and thread catcher 1 should be at the same level.

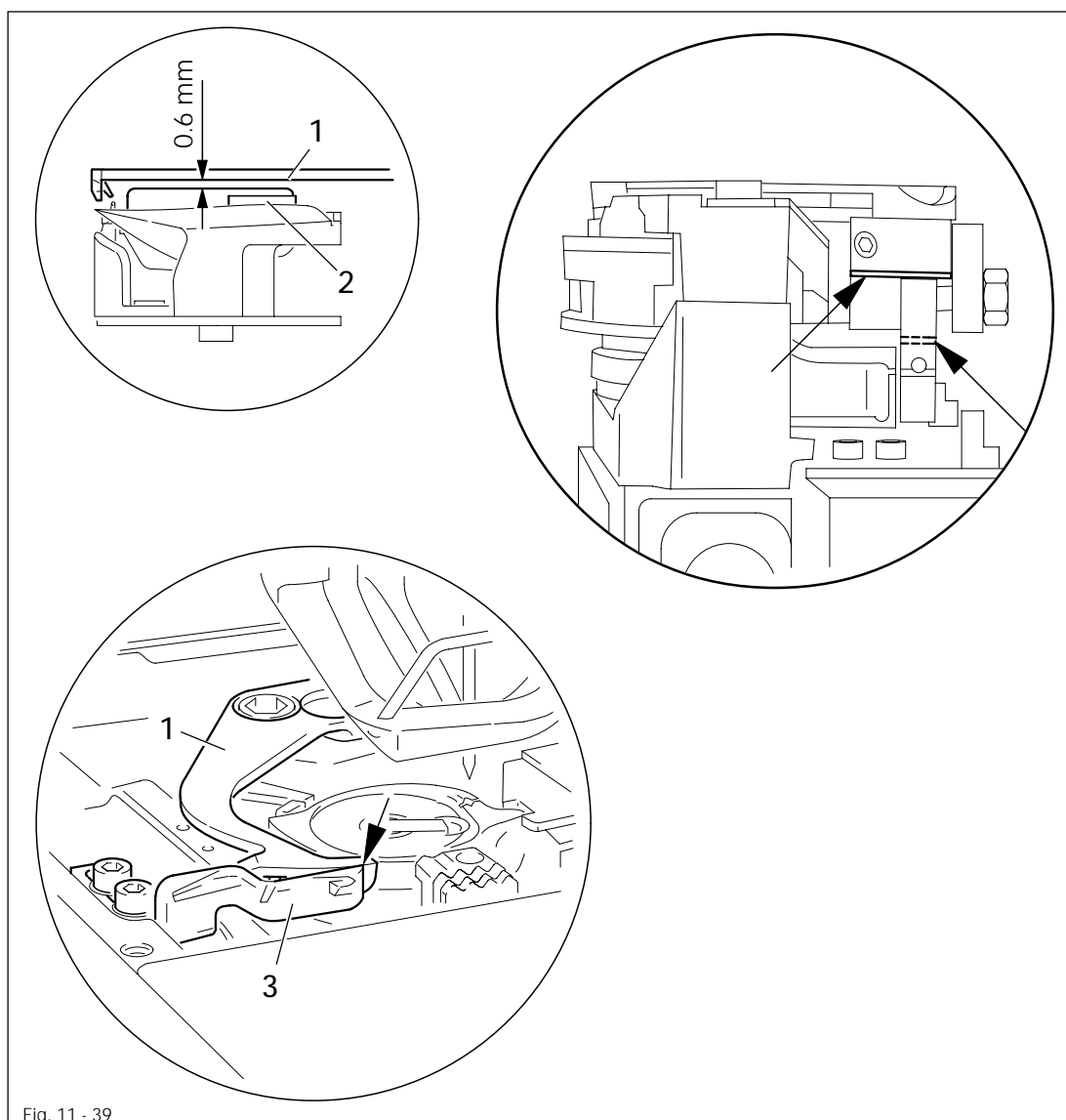

Fig. 11 - 39



The thread catcher and knife height is pre-set by the manufacturer and can only be corrected by placing washers under the thread catcher or knife mounting (see arrow).

11.07.03 Knife mounting support

Requirement

When the thread trimmer is in its cutting position, the knife mounting support 3 must be in contact with knife mounting 5.

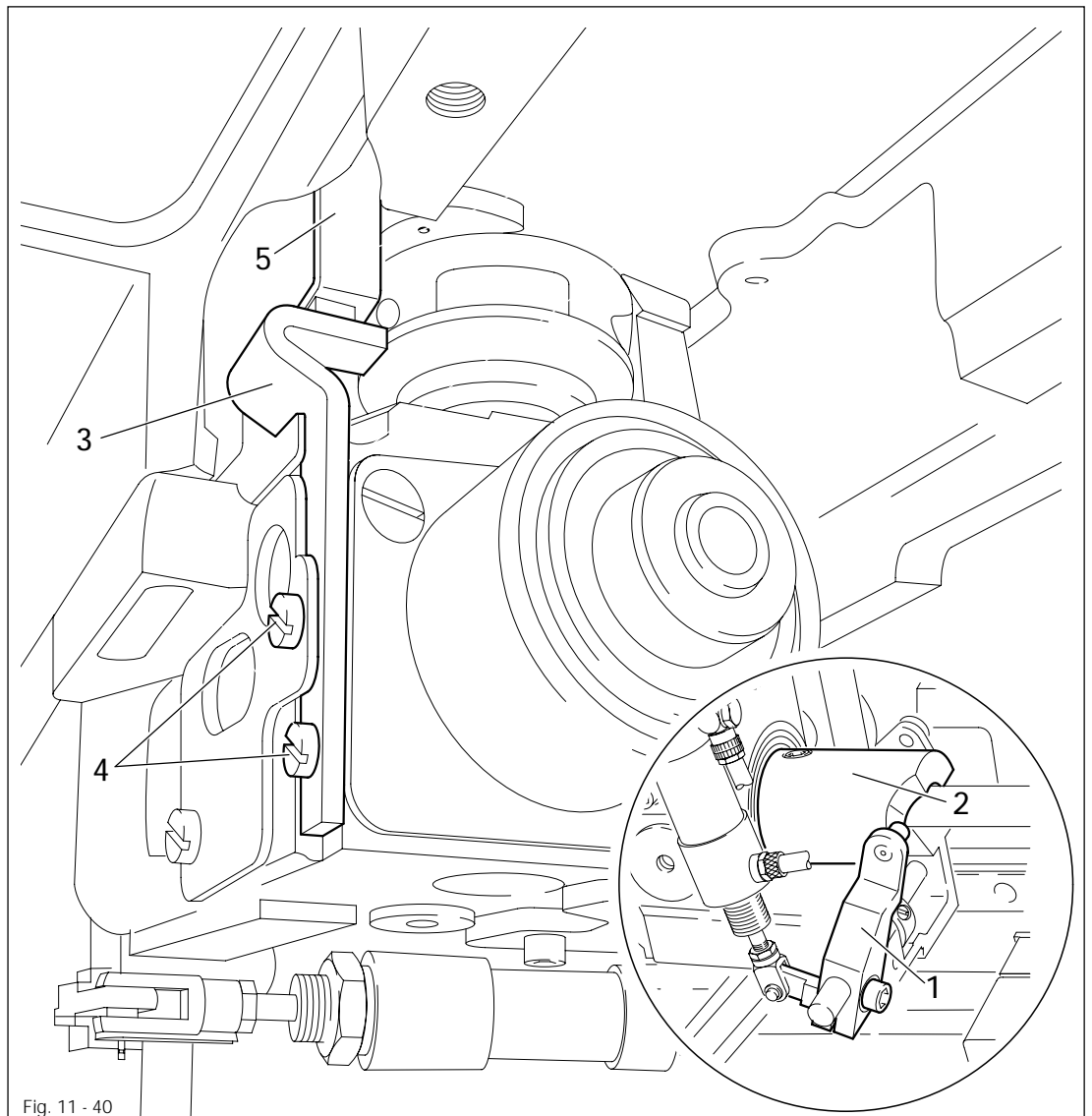

Fig. 11 - 40

- Switch off master switch and turn off compressed air.
- Bring needle to BDC and press roller lever 1 against control cam 2.
- Bring machine into cutting position.
- Adjust knife mounting support 3 (screws 4) on the rear side of the hook bearing according to the requirement.

Adjustment

11.07.04 Knife cutting position

Requirement

When the knife is in its cutting position, there should be a clearance of **34 mm** between the front edge of the knife and the front edge of the position stop 3.

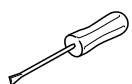
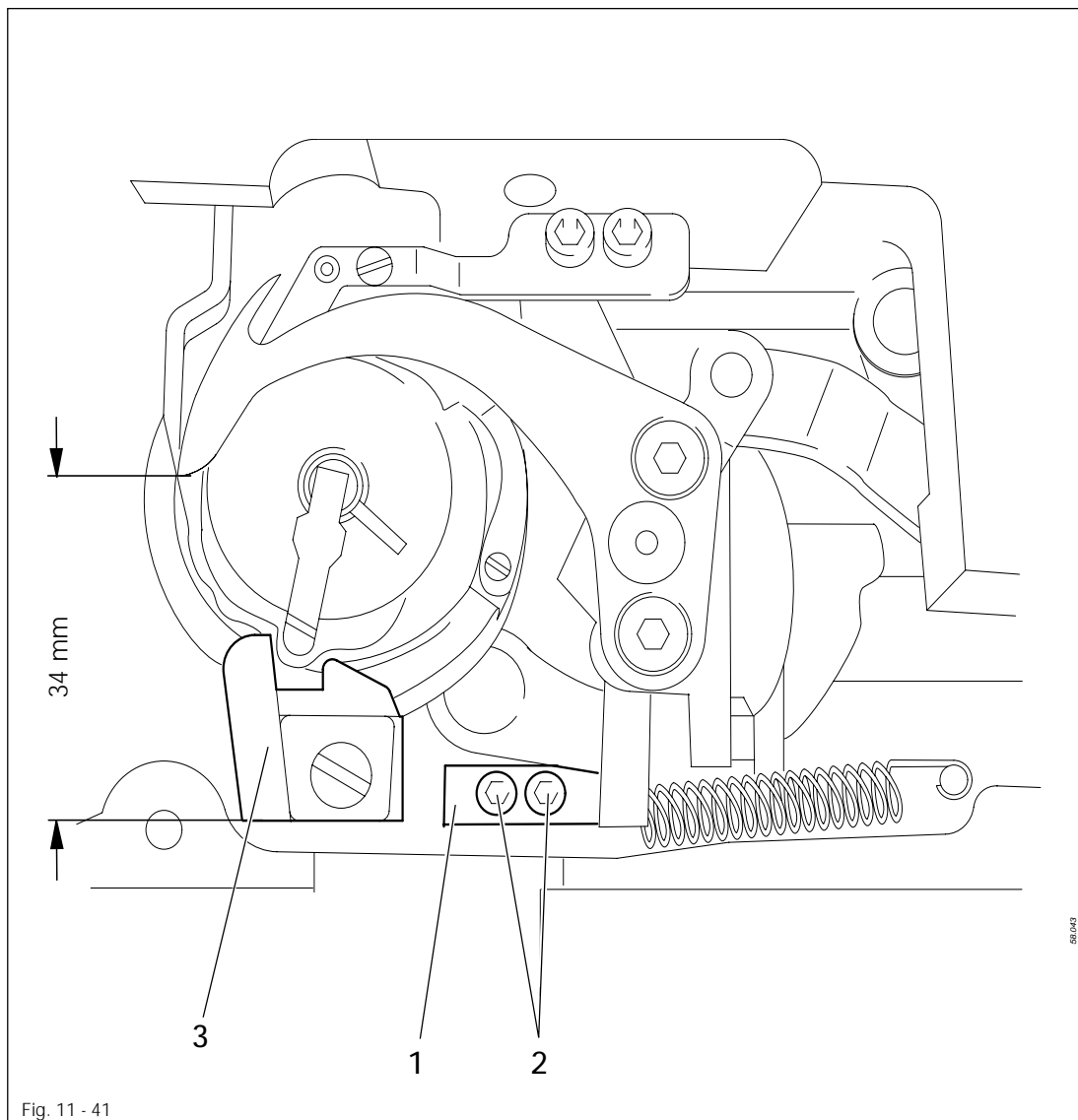

- Adjust position stop 1 (screws 2) according to the requirement.

11.07.05 Thread catcher position

Requirement

1. When the thread trimmer is in its cutting position, the edges of the thread catcher **4** and knife **8** must be flush (see arrow).
2. In this position screw **1** must be touching the knife mounting support (see arrow).

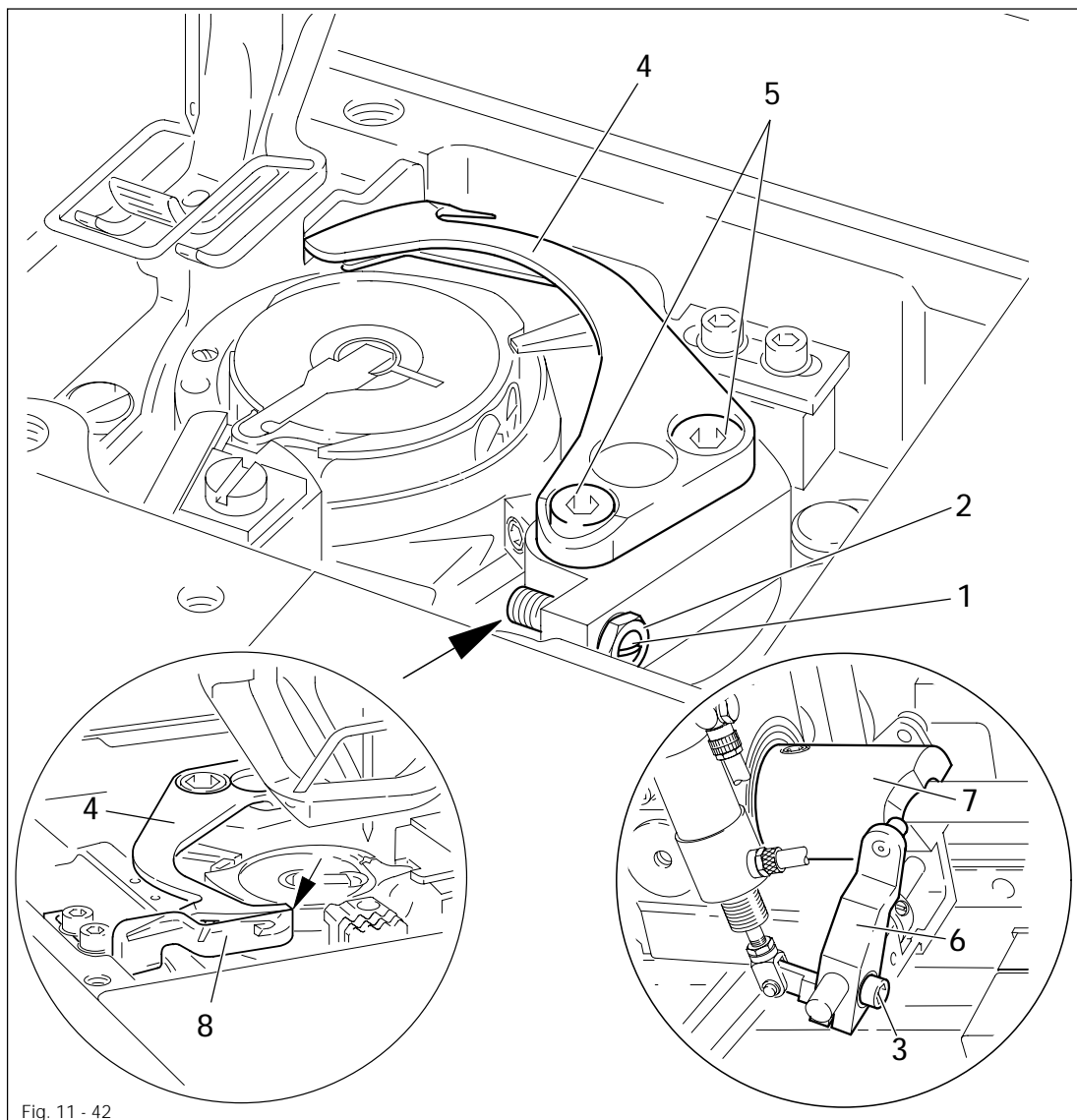
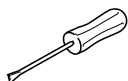

Fig. 11 - 42



- Turn screw **1** (nut **2**) about three turns.
- Loosen screw **3**.
- Bring thread catcher **4** (screws **5**) to the middle of its adjustment range.
- Bring needle to BDC and press roller lever **6** against control cam **7**.
- Bring machine into cutting position.
- Turn thread catcher **4** according to **requirement 1**.
- Tighten roller lever **6** until it is resting against control cam **7** and tighten screw **3**.
- Adjust screw **1** (nut **2**) according to **requirement 2**.

Adjustment

11.07.06 Readjustment of the control cam

Requirement

When the take-up lever is at TDC, the cutting process should just have ended.

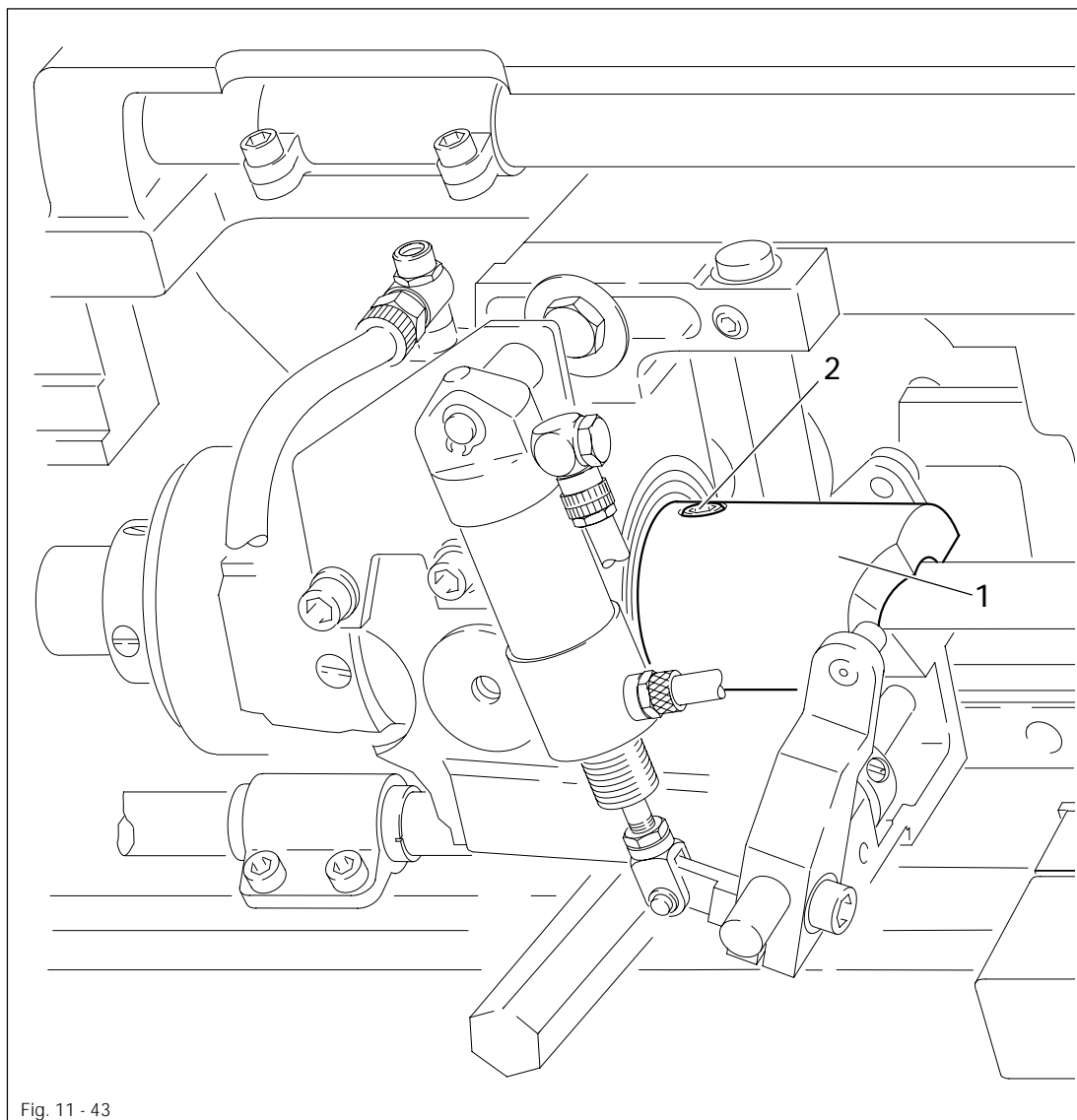
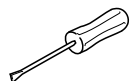

Fig. 11 - 43



- Adjust control cam 1 (screws 2) according to the requirement.

11.07.07 Knife pressure

Requirement

When the front edge of thread catcher 3 has passed the cutting edge by half, the cutting edge of the knife 4 must rest with light pressure on the edge of the catcher.

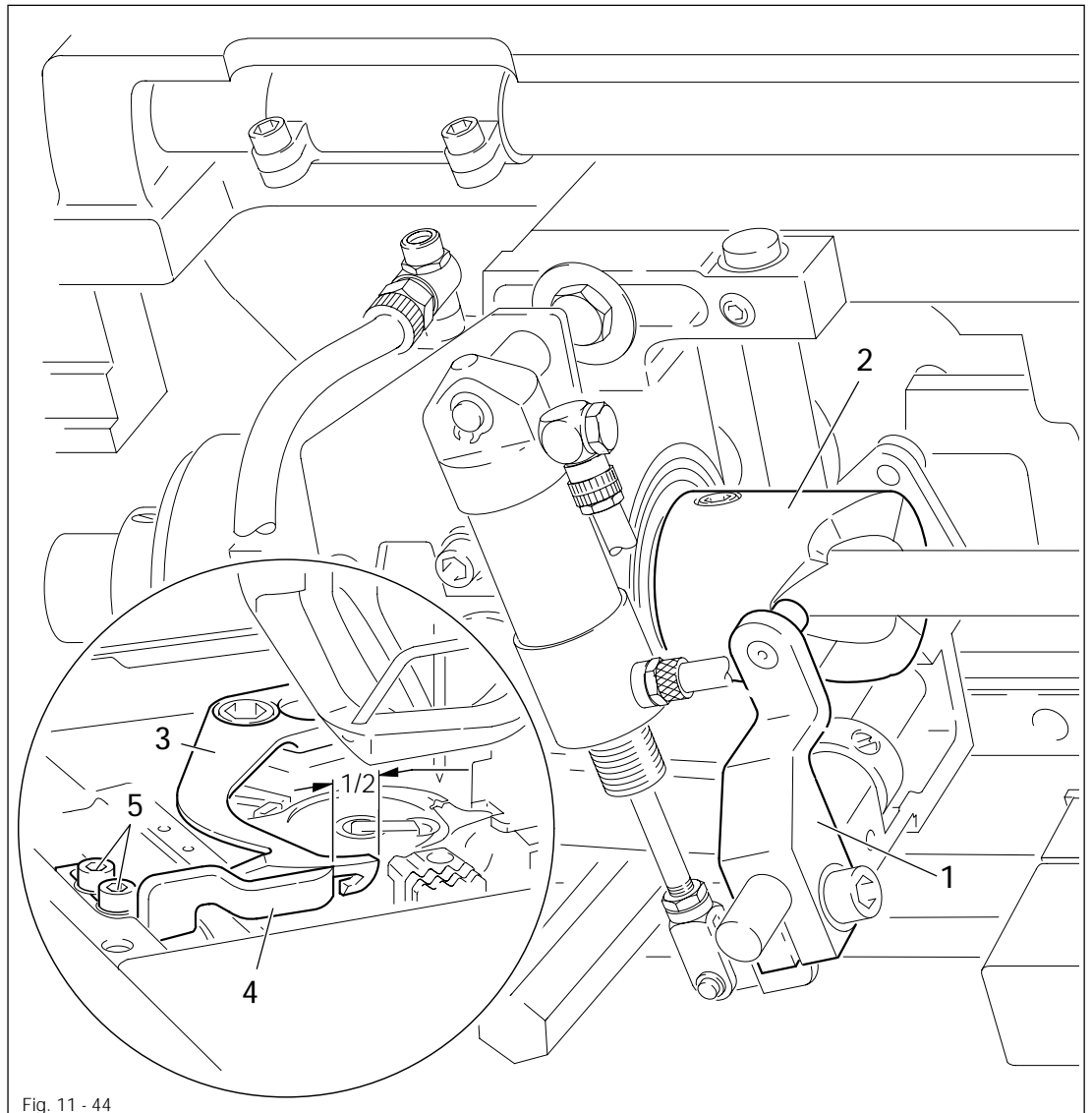
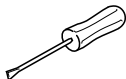

Fig. 11 - 44



- Set take-up lever at BDC and push roller lever 1 into control cam 2.
- Turn balance wheel until front edge of thread catcher 3 has passed the cutting edge of the knife 4 by half.
- Re-position knife 4 (screws 5) according to the requirement.



The knife pressure must be kept as low as possible, so that the position of the knife does not change during cutting.

11.07.08 Bobbin-thread retaining spring

Requirement

The retaining spring 1 must

1. reliably retain the bobbin thread after cutting and
2. neither hinder the thread return nor the removal and replacement of the bobbin case.

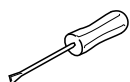
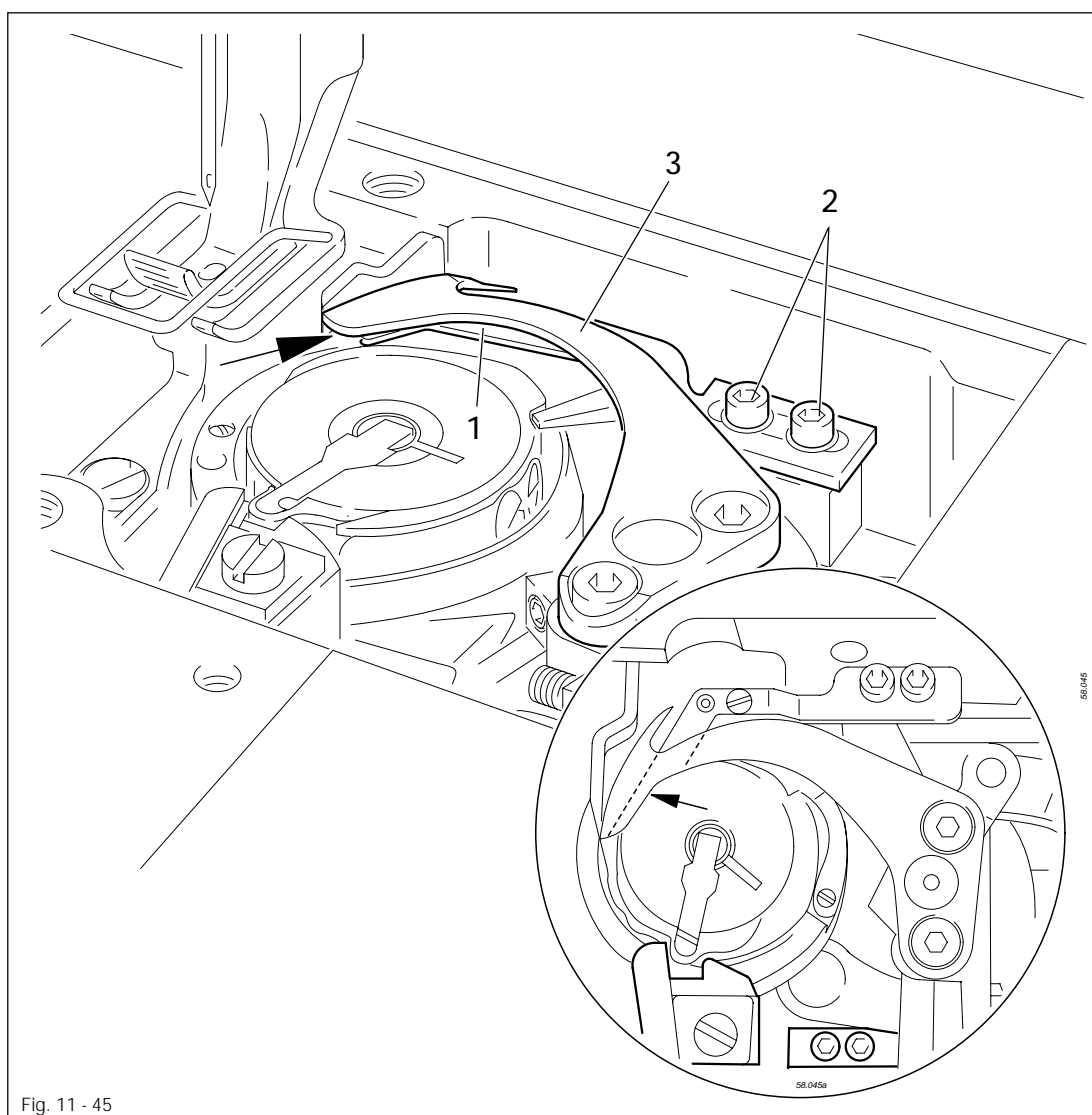

- Set thread trimmer at its resting position.
- Adjust retaining spring 1 (screws 2) so that the interior edge of the retaining spring is flush with the thread catcher 3 and as close as possible to the front edge of the thread catcher (see arrow).
- By bending retaining spring 1, adjust its height, so that the retaining spring 1 touches the bottom side of the thread catcher 3 (see arrow).

11.07.09 Manual cutting test

Requirement

1. When thread catcher 1 is on its forward stroke, it must not carry bobbin thread 3 forward too.
2. When thread catcher 1 is in its front position, the bobbin thread 3 must be positioned in the middle of the marked area (see arrow).
3. After the trimming action, both needle and bobbin thread must be perfectly cut, and bobbin thread 3 retained.

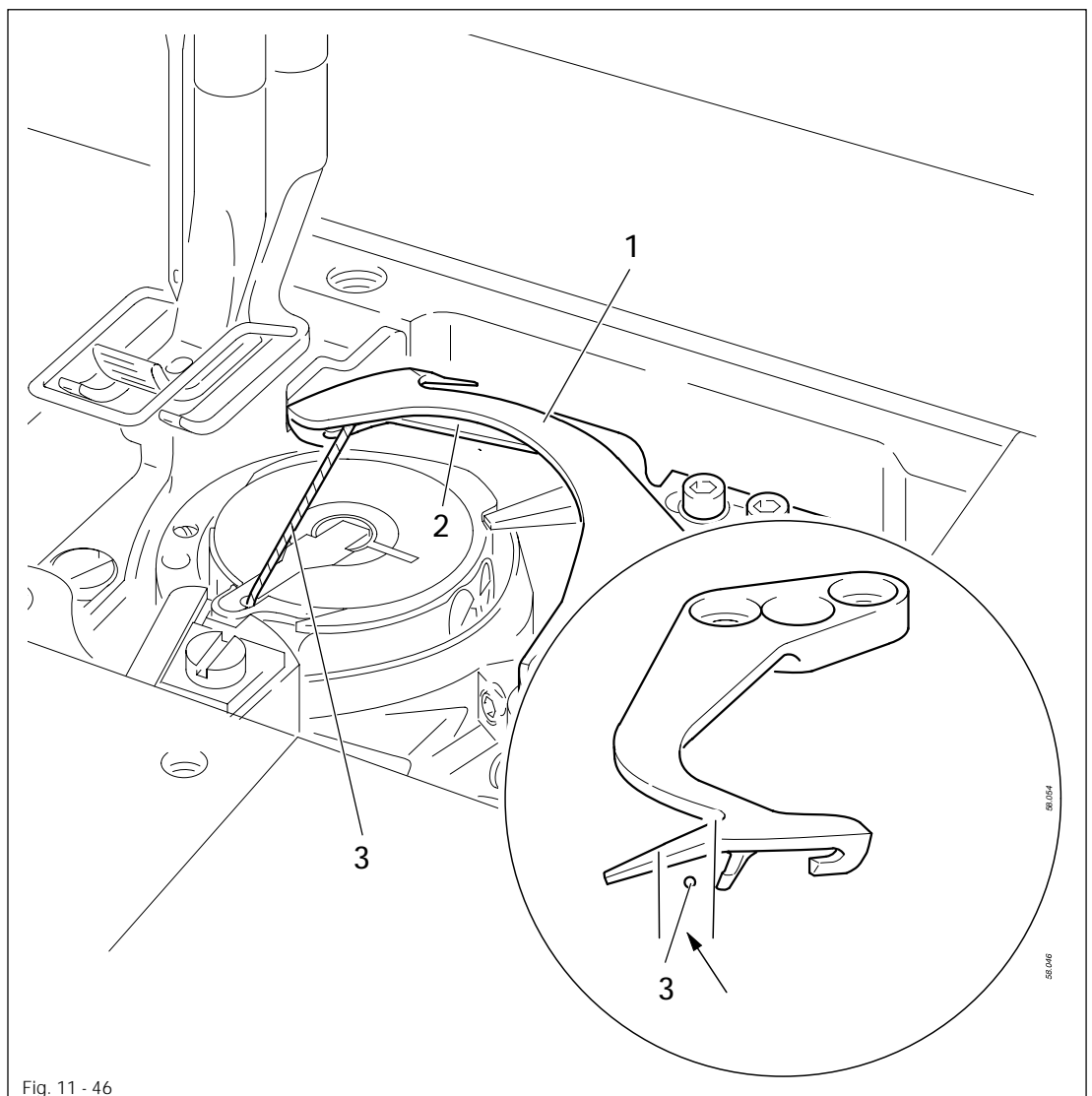
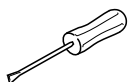

Fig. 11 - 46



- Sew a few stitches.
- Turn off the master switch and the compressed air.
- Carry out cutting test manually.
- Check **requirement 1** and readjust thread catcher 1 according to Chapter 11.07.02 **Thread catcher height** if necessary.
- Check **requirement 2** and readjust thread catcher 1 according to Chapter 11.07.05 **Thread catcher position** if necessary.
- Check **requirement 3** and readjust bobbin thread retaining spring 2 according to Chapter 11.07.08 **Bobbin thread retaining spring** if necessary.

11.08

Adjusting the bobbin-thread supply monitor -926/06

(On the PFAFF 1426 carry out this adjustment on both hooks)

Requirement

When the reflection surface is positioned at the transmitting and receiving unit, the luminous diode on the amplifier must light up and the highest possible voltage applied.

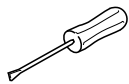
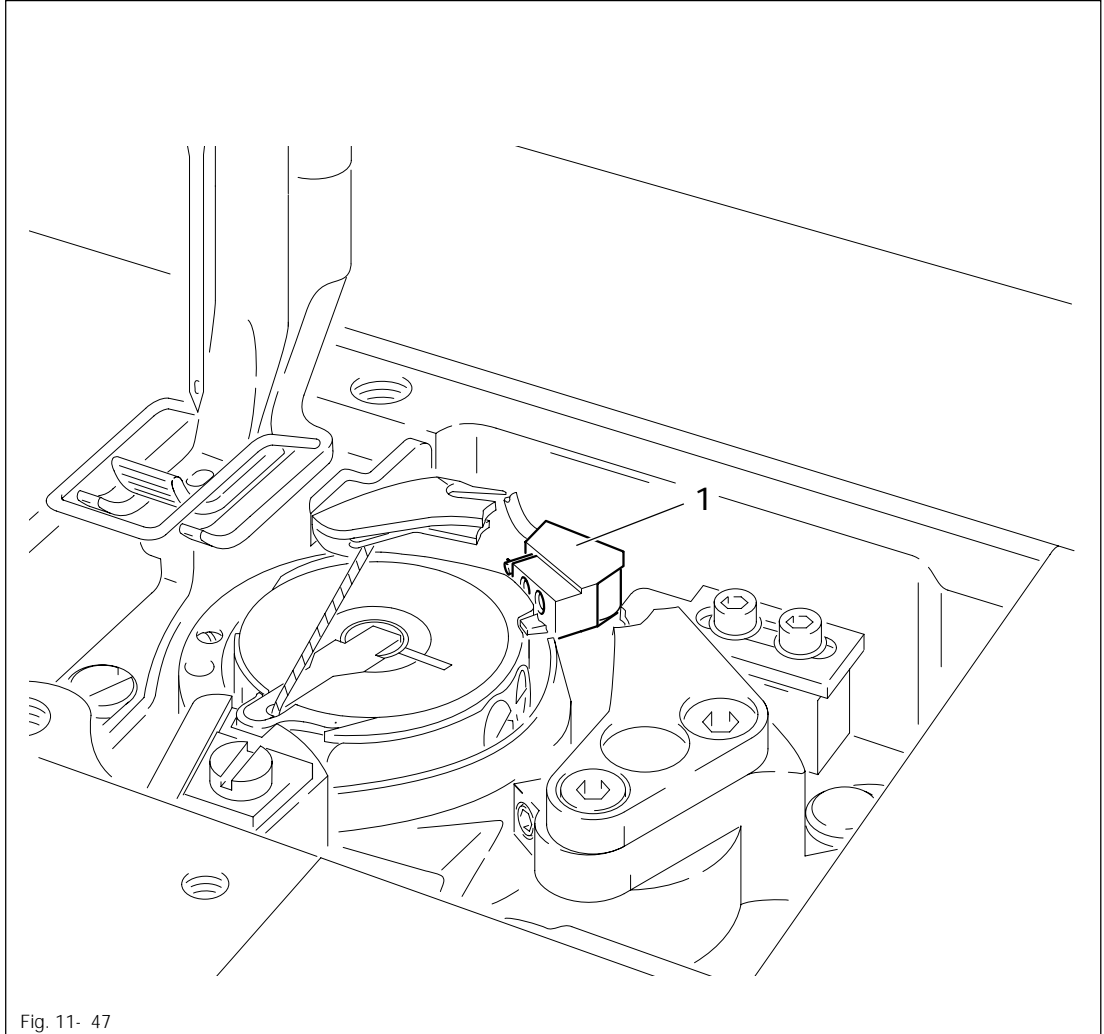

- Wind thread onto bobbin core without covering the bobbin reflection surfaces.
- Insert bobbin in hook.
- Connect amplifier on control box.
- Turn rotary potentiometer on regulator amplifier, part No. 71-8500-0091 to set highest voltage (P_{max}).
- Connect multiple tester (measuring range DC 6.5 V) to measuring sockets of amplifier. Switch on tester.
- To position the bobbin reflection surface at transmitting and receiving unit 1, pull the bobbin thread slowly until luminous diode on amplifier lights up.
- Position transmitting and receiving unit 1 by bending it so that the voltage reading is at its highest.
- If the voltage rises above 6.5 V, reduce it to 3 V and repeat this procedure until the highest possible voltage is obtained.

11.09 Parameter settings

11.09.01 Selecting and changing parameters

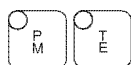

- Simultaneously press and hold down the "PM" and "TE" keys and switch on the machine.



- Press the "TE" key (LED on)

104

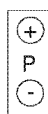
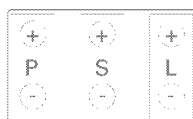

- Select the desired group, e.g. "700", by pressing +/- on the "P" key.

700

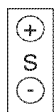
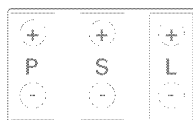

- Select the desired parameter, e.g. "726", by pressing +/- on the "S" key.

726

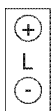

- Activate the desired setting (e.g. counter for bobbin control) by pressing +/- on the "L" key.



- Save the input by pressing the "TE" key (LED off).

11.09.02 List of parameters

Group	Parameter	Description	Adjustm. range	Standard value with -926/06	Standard value with -926/07
4	402	Speed when adjusting stroke	300 - 6400	1800	1800
5	573	Speed limiter (small stroke)	300 - 6400	3000	3000
	574	Speed limiter (large stroke)	300 - 6400	2200	2200
6	601	Cut I = yes II = no		I	I
	605	Actual value on display I = on II = off		II	I
	607	Max. speed	100 - 10000	4000	4000
	609	Cutting speed 1	30 - 300	180	180
	618	Reverse		I	I
	660	Bobbin monitoring function I = on II = off		I	II
7	700	Needle position 0 Needle reference position	0 - 239		
	701	Angle setting I = Synchroniser setting with balance wheel II = Synchroniser setting with "+" and "-" keys		I	I
	702	Needle position 1 (needle lowered)	0 - 239	80	80
	703	Needle position 2 (take-up lever raised) ♦ with -900/81; ▲ with -900/82	0 - 239	213♦ 225▲	213♦ 225▲
	705	Needle position 5 (end cutting signal 1) ♦ with -900/81; ▲ with -900/82	0 - 239	175♦ 225▲	175♦ 225▲

225.

Group	Parameter	Description	Adjustm. range	Standard value with -926/06	Standard value with -926/07
7	707	Needle position 6 (Start tension release signal 2)	0 - 239	185	185
	725	Display on operating panel corresponds to I = Actual speed II = remaining stitches for bobbin thread		I	II
	726	Counter for bobbin monitoring I = activated II = deactivated		II	I
	727	Counter for bobbin monitoring brings I = stop and signal at output Y36 II = signal at output Y36 without stop			II
	793	Delay from "feed resetting on" to "cut" for shortened trim stitch	0 - 2550	140	140
8	801	Reverse angle		30	30
9	988	Shortened trim stitch		II	I



For more information and displays see the motor instruction manual.

12

Wearing parts



This list indicates the most important wearing parts.

You can request a detailed parts list for the complete machine under parts number 296-12-18 403.

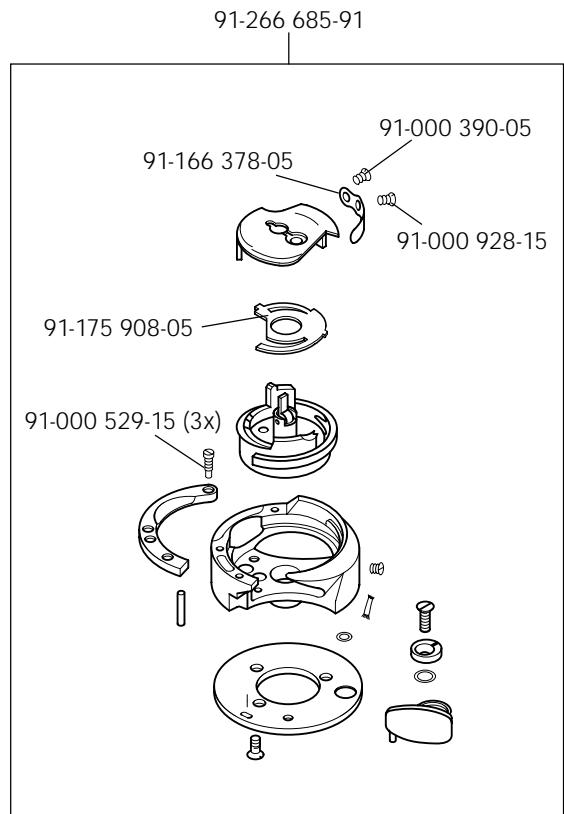
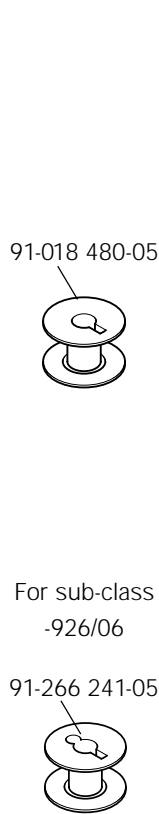
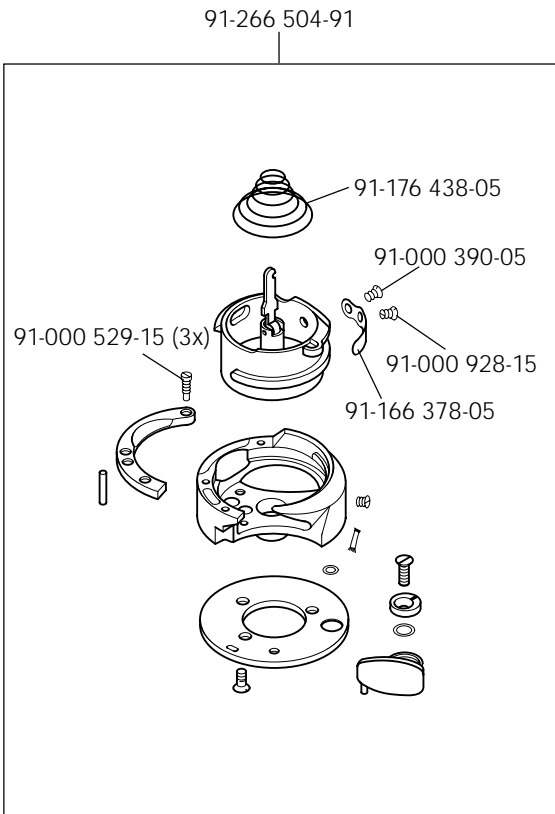
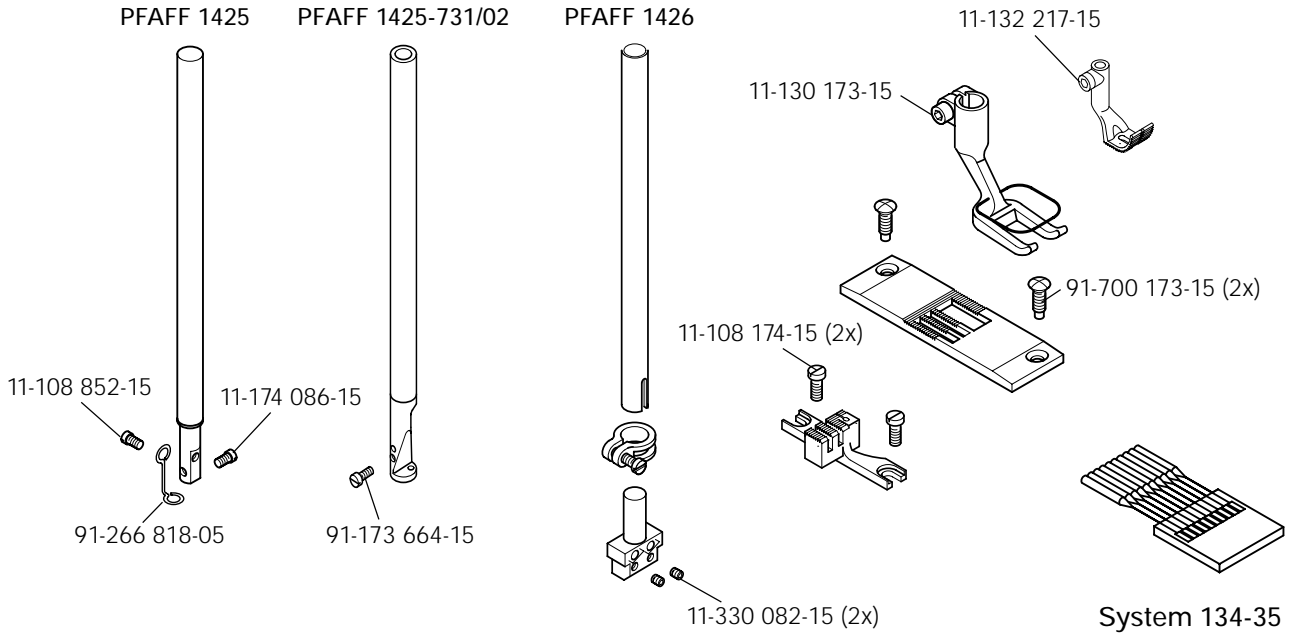

-900/81

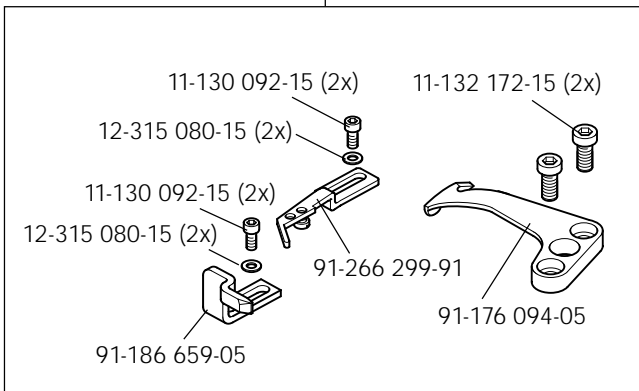

-900/82

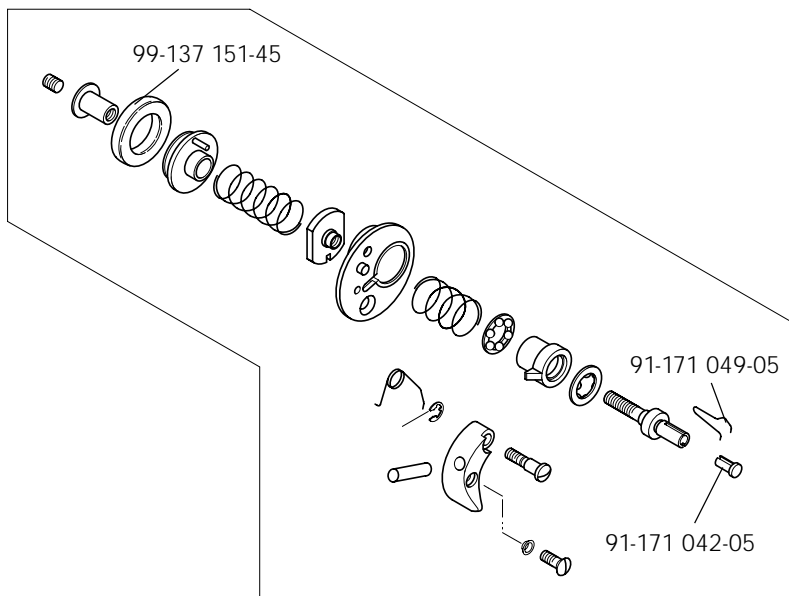
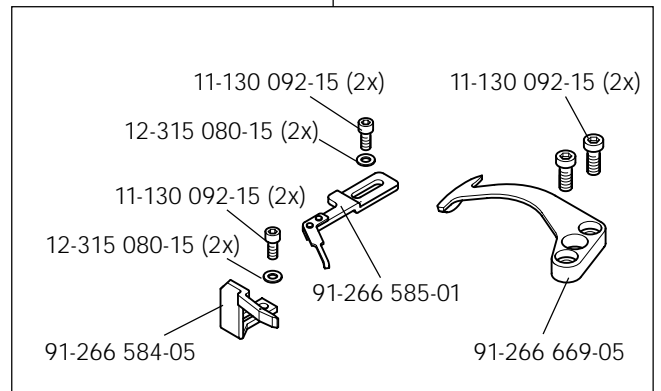

PFAFF 1425

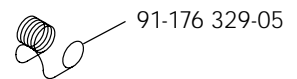

PFAFF 1426

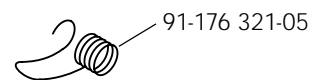

Cutting depth 2.5 - 4.9 mm

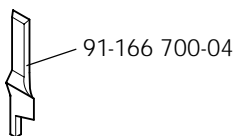

Cutting depth 5,0 - 8,0 mm

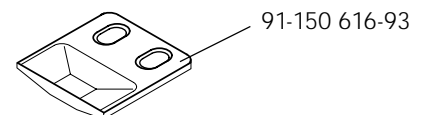
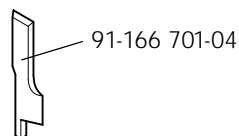

PFAFF

**G.M. PFAFF KAISERSLAUTERN
INDUSTRIEMASCHINEN AG**

Postfach 3020
D-67653 Kaiserslautern

Königstr. 154
D-67655 Kaiserslautern

Telefon: (0631) 200-0
Telefax: (0631) 17202
E-Mail: info@pfaff-industrial.com

Gedruckt in der BRD
Printed in Germany
Imprimé en R.F.A.
Impreso en la R.F.A.