

PFAFF

3519-3/12

Instruction manual

At time of printing, all information and illustrations contained in this document were up to date.

Subject to alteration

The reprinting, copying or translation of PFAFF Instruction Manuals, whether in whole or in part, is only permitted with our previous permission and with written reference to the source.

G.M. PFAFF
Aktiengesellschaft

Postfach 3020
D-67653 Kaiserslautern
Königstr. 154
D-67655 Kaiserslautern

Editing / Illustration
HAAS-Publikationen GmbH
D-53840 Troisdorf

	Contents	Chapter - Page
1	Safety	1 - 1
1.01	Directives	1 - 1
1.02	General notes on safety	1 - 1
1.03	Safety symbols	1 - 2
1.04	Built-in safety systems	1 - 2
1.05	Important points for the user	1 - 3
1.06	Operating and specialist personnel	1 - 3
1.06.01	Operating personnel	1 - 3
1.06.02	Specialist personnel	1 - 4
1.07	Danger	1 - 4
2	Proper use	2 - 1
3	Specifications	3 - 1
4	Disposal of machine waste	4 - 1
5	Notes on testing in accordance with EN 60204-3-1	5 - 1
6	Transport, packaging and storage	6 - 1
6.01	Transport to the customer's premises	6 - 1
6.02	Transport within the customer's premises	6 - 1
6.03	Disposal of the packaging	6 - 1
6.04	Storage	6 - 1
7	Explanation of the symbols	7 - 1
8	Operational controls	8 - 1
8.01	On/Off switch	8 - 1
8.02	EMERGENCY STOP button	8 - 1
8.03	Pedal	8 - 2
8.04	Start keys	8 - 2
8.05	Adjustment dial for dart depth	8 - 3
8.06	Control panel	8 - 4
8.06.01	Messages in the display	8 - 4
8.06.02	Functions of the keys	8 - 5
9	Installation and commissioning	9 - 1
9.01	Unpacking and incoming materials control	9 - 1
9.02	Connecting the compressed air system	9 - 1
9.02.01	Aligning the machine	9 - 1
9.02.02	Connecting the compressed air system	9 - 2
9.02.03	Connecting the electricity supply	9 - 2
9.02.04	Connecting the pedal	9 - 3
9.02.05	Connecting the vacuum motor	9 - 3
9.02.06	Installing and aligning the laser	9 - 4
9.03	Commissioning	9 - 4

	Contents	Chapter - Page
10	Switching the machine on/off	10 - 1
10.01	Commissioning/shutting down the machine	10 - 1
10.02	Switching the machine off in an emergency	10 - 2
10.03	Interrupting the operation of the machine	10 - 2
11	Preparation	11 - 1
11.01	Inserting the needle	11 - 1
11.02	Winding the bobbin thread, adjusting the primary thread tension	11 - 2
11.03	Changing the bobbin, threading the bobbin case and adjusting the thread tension	11 - 3
11.04	Threading the needle thread, adjusting the thread tension	11 - 4
11.05	Changing the dart insert	11 - 5
12	Programming and sewing	12 - 1
12.01	Description of the seam type	12 - 1
12.02	Programming	12 - 2
12.02.01	Menu functions	12 - 3
12.02.02	Description of the menus	12 - 4
12.02.03	Moving amongst the menu functions	12 - 8
12.02.04	Writing a program	12 - 8
12.02.05	Altering an existing program	12 - 9
12.02.06	Correction values	12 - 9
12.02.07	Returning the daily unit counter to "0"	12 - 10
12.02.08	Altering the bobbin thread allocation	12 - 10
12.02.09	Error messages in the display	12 - 10
12.02.10	Program change	12 - 11
12.03	Sewing	12 - 11
12.04	Inserting the workpiece	12 - 12
12.04.01	Inserting the the workpiece with the positioning pipe	12 - 12
12.04.02	Inserting the workpiece with the loading table	12 - 14
13	Care and maintenance	13 - 1
13.01	Cleaning	13 - 2
13.01.01	Cleaning the entire machine	13 - 2
13.01.02	Cleaning the hook and the hook race	13 - 3
13.02	Lubricating the cutter	13 - 4
13.03	Checking the air filter	13 - 5
13.03.01	Checking and adjusting the air pressure	13 - 5
13.03.02	Checking and topping up the oil level	13 - 6
13.03.03	Checking the water level and emptying the water trap	13 - 7
13.03.04	Cleaning the air filter	13 - 7
13.03.05	Adjusting the drip feed rate on the oil vaporizer	13 - 7
13.03.06	Cleaning the vaporizer jet	13 - 7
13.04	Lubricating the cylinder for the runner	13 - 8
13.05	Checking and topping up the oil level for the sewing machine	13 - 9

Contents		Chapter - Page
14	Adjustment	14 - 1
14.01	Tools, gauges and other accessories	14 - 1
14.02	Pulling out the sewing head	14 - 2
14.03	Pushing in the sewing head	14 - 3
14.04	Lengthwise pre-adjustment of the sewing head	14 - 4
14.05	Loading table	14 - 5
14.05.01	Basic height setting of the loading table	14 - 5
14.05.02	Parallelism of the loading table	14 - 6
14.05.03	Retraction depth of the loading table	14 - 7
14.06	Sewing head	14 - 8
14.06.01	Height of the sewing head	14 - 8
14.06.02	Lateral alignment of the sewing head	14 - 9
14.07	Work surface	14 - 10
14.08	Positioning pipe	14 - 11
14.08.01	Pre-adjusting the positioning pipe	14 - 11
14.08.02	Parallelism of the positioning pipe	14 - 12
14.08.03	Height of the positioning pipe	14 - 13
14.09	Needles	14 - 14
14.10	Loop spreader	14 - 15
14.11	Table extension	14 - 16
14.12	Pre-loading station	14 - 17
14.12.01	Height of the pre-loading station	14 - 17
14.12.02	Position of the pre-loading station	14 - 18
14.13	Brushes	14 - 19
14.13.01	Long brush row	14 - 19
14.13.02	Short brush row	14 - 20
14.14	Catcher-knife unit	14 - 21
14.14.01	Pre-adjusting the catcher-knife unit	14 - 21
14.14.02	Recuperator spring of the catcher	14 - 22
14.14.03	Height of the knife unit	14 - 23
14.14.04	Changing the knife	14 - 24
14.15	Workholder bar	14 - 25
14.15.01	Zero point of the workholder bar in Y-direction	14 - 25
14.15.02	Pneumatic workholder-bar pressure	14 - 26
14.15.03	Stop of the workholder bar	14 - 27
14.16	Pneumatic table pressure	14 - 28
14.17	Pressure monitor	14 - 29
14.18	Stacker	14 - 30
14.19	Checking and adjustment aid for adjusting the sewing head	14 - 31
14.20	Pre-adjusting the needle height	14 - 32
14.21	Zeroing the feed dog	14 - 33
14.21.01	Adjustment with gearbox housing closed	14 - 33
14.21.02	Adjustment with gearbox housing open	14 - 34

	Contents	Chapter - Page
14.22	Vibrating presser lifting motion	14 - 35
14.23	Vibrating presser height	14 - 36
14.24	Vibrating presser feeding motion	14 - 37
14.25	Centering the needle in the needle hole	14 - 38
14.26	Eccentric hook-shaft-bearing and hook-to-needle clearance	14 - 39
14.27	Final adjustment of needle rise and needle height and bobbin case position finger	14 - 40
14.28	Bobbin case opener height	14 - 41
14.29	Bobbin case opener position	14 - 42
14.30	Bobbin case opener motion	14 - 43
14.31	Clearance between presser foot and needle plate	14 - 44
14.32	Needle thread tension release	14 - 45
14.33	Thread check spring and slack thread regulator	14 - 46
14.34	Bobbin winder	14 - 47
14.35	Stitch length limitation	14 - 48
14.36	Stitch length adaptation	14 - 49
14.37	Presser foot pressure	14 - 50
14.38	Thread trimmer	14 - 51
14.38.01	Pre-adjusting the control cam	14 - 51
14.38.02	Feed regulator	14 - 52
14.38.03	Pawl	14 - 53
14.38.04	Engaging solenoid	14 - 54
14.38.05	Actuating lever	14 - 55
14.38.06	Engaging lever	14 - 56
14.38.07	Lateral alignment of the thread catcher	14 - 57
14.38.08	Front point of reversal of the thread catcher	14 - 58
14.38.09	Final adjustment of the control cam	14 - 59
14.38.10	Catch spring	14 - 60
14.38.11	Knife-to-needle clearance	14 - 61
14.38.12	Manual cutting check	14 - 62
14.38.13	Needle thread tension release	14 - 63
14.38.14	Synchronizer	14 - 64
14.38.15	Mounting and dismounting the control unit	14 - 65

1 Safety

1.01 Directives

The machine was built in accordance with the following European regulations:

- EC Machine Directive (89/392/EEC, 91/368/EEC, 93/44/EEC, 93/68/EEC)
- Safety of Appliances Law, Machine Ordinance - 9GSGV
- EC Lowly Voltage Directrive (73/23/EEC, 93/68/EEC)
- EC Directive "Electromagnetic Compatibility" (89/336/EEC, 92/31/EEC, 93/68/EEC)
- EN 60204-3-1: edition 1/86 Safety of Machines, Electrical Equipping of Industrial Machines
- EN 292 Parts 1 and 2: Edition 9/91 Safety of Machines (Basic Terms)
- DIN 5310: Edition 9/80 Industrial Sewing Machines (safety requirements)
- DIN 5318 T2: edition 9/78 Industrial Sewing Machines - presser foot (safety requirements)
- DIN 45635 T48: edition 12/87 Measurement of Noise Levels

In addition to this Instruction Manual, observe also all generally accepted, statutory and other regulations and legal requirements and all valid environmental protection regulations! The regionally valid regulations of the social insurance society for occupational accidents or other supervisory organisations are to be strictly adhered to!

1.02 General notes on safety

- This machine may only be operated by adequately trained operators and only after having completely read and understood the Instruction Manual!
- All Notes on Safety and Instruction Manuals of the motor manufacturer are to be read before operating the machine!
- The danger and safety instructions on the machine itself are to be followed!
- This machine may only be used for the purpose for which it is intended and may not be operated without its safety devices. All safety regulations relevant to its operation are to be adhered to.
- When exchanging sewing tools (e.g. needle, presser foot, needle plate, feed dog or bobbin), when threading the machine, when leaving the machine unattended and during maintenance work, the machine is to be separated from the power supply by switching off the On/Off switch or by removing the plug from the mains!
- Everyday maintenance work is only to be carried out by appropriately trained personnel!

- Repairs and special maintenance work may only be carried out by qualified service staff or appropriately trained personnel!
- When servicing or carrying out repairs on pneumatic devices, the machine is to be removed from the compressed air supply! The only exceptions to this are adjustments and function checks carried out by appropriately trained personnel!
- Work on electrical equipment may only be carried out by appropriately trained personnel!
- Work is not permitted on parts and equipment which are connected to the power supply! Exceptions to this are only to be found in the regulations EN 50110.
- Modifications and alterations to the machine may only be carried out under observance of all the relevant safety regulations!
- Only spare parts which have been approved by us are to be used for repairs! We expressly point out that any replacement parts or accessories which are not supplied by us have not been tested and approved by us. The installation and/or use of any such products can lead to negative changes in the structural characteristics of the machine. We shall not be liable for any damage which may be caused by non-original parts.

1.03 Safety symbols



Danger!
Points to be observed.



Danger of injury for operating and specialist personnel!



Danger: Laser beam!

1.04 Built-in safety systems

This machine has an EMERGENCY STOP key which can be used to stop the machine at any time in cases of danger or emergency.

Furthermore, the machine has a safety cover for the needle and cutting area which must be closed when the machine is operating.

1.05 Important points for the user

- This Instruction Manual is a component part of the machine and must be available to the operating personnel at all times.
- The Instruction Manual must be read before operating the machine for the first time.
- The operating and specialist personnel is to be instructed as to the safety equipment of the machine and regarding safe work methods.
- It is the duty of the operator to only operate the machine in perfect running order.
- It is the obligation of the operator to ensure that none of the safety mechanisms are removed or deactivated.
- It is the obligation of the operator to ensure that only authorized persons operate and work on the machine.

Further information can be obtained at your PFAFF agent.

1.06 Operating and specialist personnel

1.06.01 Operating personnel

Operating personnel are persons responsible for the equipping, operating and cleaning of the machine as well as taking care of faults arising in the sewing area.

The operating personnel is obliged to observe the following points and must:

- always observe the Notes on Safety in the Instruction Manual!
- never use any working methods which could limit the level of safety in using the machine!
- not wear loose-fitting clothing or jewellery such as chains or rings!
- also ensure that only authorized persons have access to the potentially dangerous area around the machine!
- always immediately report to the person responsible any changes in the machine which may limit its safety!

1.06.02 Specialist personnel

Specialist personnel are persons with a specialist education in the fields of electrics/electronics, pneumatics and mechanics. They are responsible for the lubrication, servicing, repairing and adjusting of the machine.

The specialist personnel is obliged to observe the following points and must:

- always observe the Notes on Safety in the Instruction Manual!
- switch off the On/Off switch before carrying out adjustments or repairs and ensure that it cannot be switched on again unintentionally!
- never work on parts which are still connected to the power supply! Exceptions are contained only in the regulations EN 50110.
- when servicing or carrying out repairs on pneumatic devices, remove the machine from the compressed air supply! The only exceptions to this are function checks.
- replace the protective coverings and close the electrical control box after all repairs or maintenance work!

1.07 Danger



A working area of **1 meter** is to be kept free both in front of and behind the machine while it is in operation so that it is always easily accessible.



Never reach into the sewing area while sewing! Danger of injury by the needle!



Never leave objects on the table or in the needle plate area while adjusting the machine settings! Objects can become trapped or be slung away! Danger of injury!



Do not look into the laser beam, not even with optical devices!

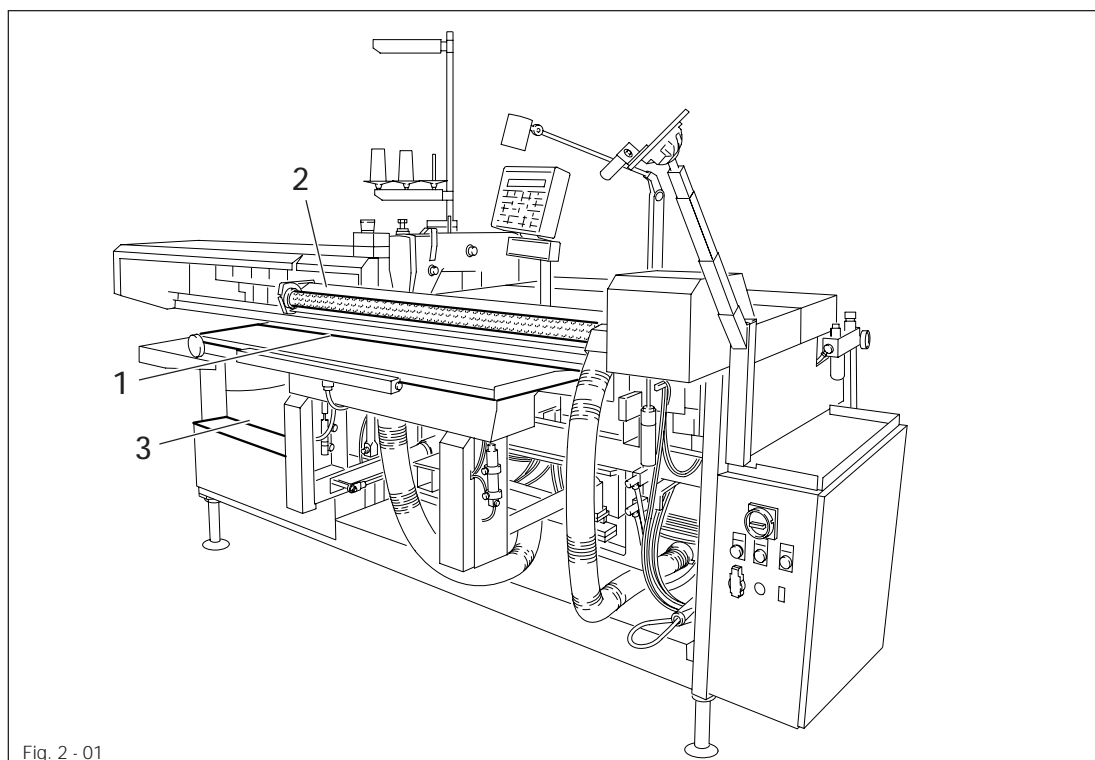

Fig. 2 - 01

The PFAFF 3519 - 3/12 is for the manufacture of single or double pointed jacket breast darts. The workpiece is inserted either via the loading table 1 or the positioning pipe 2. The seam is sewn by a program. The sewn workpieces are stacked on the depositing rack 3.



Any and all uses of these machines which have not been approved of by the manufacturer are considered to be inappropriate! The manufacturer cannot be held liable for any damaged caused by the inappropriate use of the machines! The appropriate use of the machines includes the observance of all operational, adjustment, maintenance and repair measures required by the manufacturer!

3 Specifications

Dart length:	80 - 395 mm
Dart depth:	4.5 - 12 mm*
Backtack length:	0 - 9 mm
Stitch-condensation stitch length:	0.5 - 3.0 mm
Stitch-condensation length:	6 - 12 mm
Sewing head:	PFAFF 483
Speed:	max. 4300 spm
Stitch type:	301 (lockstitch)
Sewable fabric thickness:	max. 4 mm
Sewing motor:	servomotor
Motor speed:	max. 4300 rpm
Wattage:	2.5 kW
Working air pressure:	6 bar
Air consumption:	~25 l / work cycle
Working noise level:	
Emission at workplace at sewing speed of $n = 4300 \text{ min}^{-1}$:	$L_{pA} \leq 80 \text{ dB(A)}$
((noise measurement in accordance with DIN 45 635-48-B-1)	
Machine dimensions:	
Length:	approx. 2800 mm
Width:	min. 1200 mm; max. 1800 mm
Height:	min. 1200 mm; max. 1800 mm
Weight (without blower):	approx. 657 kg
Blower weight:	approx. 35 kg
Needle system:	134
Needle thickness:	90 NM

- * Single point darts with dart depths of 6-12 mm can be sewn with the PFAFF 3519-3/12. The 4.5 mm listed as the dart depth serve only as an additional correction option for the minimum dart depth of 6.0 mm.
Darts with a dart depth of less than 6.0 mm are not provided for.

4 Disposal of machine waste

- The proper disposal of machine waste is the responsibility of the customer.
- The materials used on the machines are steel, aluminium, brass and various plastics. The electrical equipment consists of plastics and copper.
- The machine waste is to be disposed of in accordance with the locally valid environmental protection regulations.



Special care is to be taken that parts soiled with lubricants are separately disposed of in accordance with the locally valid pollution control regulations!

5 Notes on testing in accordance with EN 60204-3-1

The machine was tested in accordance with EN 60204-3-1 edition 1/86 before delivery. The following tests were carried out on the machine:

- Continuous connection of the protective conductor systems
 - a) Visual check
 - b) Check of the connection of the protective conductor
- Insulation check
- Voltage check
- Function check

6 Transport packaging and storage

6.01 Transport to the customer's premises

Within the Federal Republic of Germany, the machine is delivered without packaging. Machines are packaged for export.

6.02 Transport within the customer's premises

The manufacturer carries no liability for transport within the customer's premises.

6.03 Disposal of the packaging

The packaging of the machine consists of wood, paper, cardboard and VCE fibre. The proper disposal of the packaging is the responsibility of the customer.

6.04 Storage

The machine can be stored for up to 6 months if not in use. During this time it should be protected from dust and moisture.

For longer storage the individual parts of the machine, especially the moving parts, should be protected against corrosion, e.g. by a film of oil.

Explanation of the symbols

7 Explanation of the symbols

In the following section of this Instruction Manual, certain tasks or important pieces of information are accentuated by symbols.

The symbols used have the following meanings:



Note, information



Cleaning, care



Lubrication, greasing

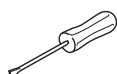

Servicing, repairing,
adjustment, maintenance

8 Operational controls

8.01 On/Off switch

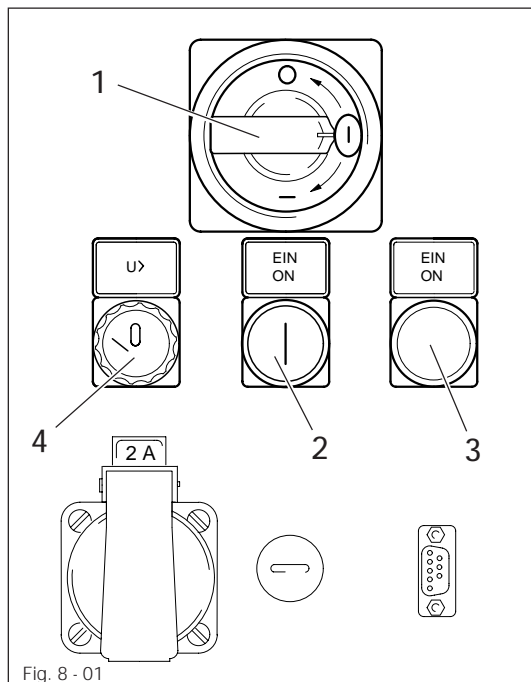

Fig. 8 - 01

- Switch the machine on and off by turning switch 1.
- Turn the control on with key 2. When the control is on, control lamp 3 is lit.
- Select the type of workpiece insertion using turn-switch 4.
 - 0 = Insert workpiece using positioning pipe.
 - 1 = Insert workpiece using positioning pipe.

8.02 EMERGENCY STOP button

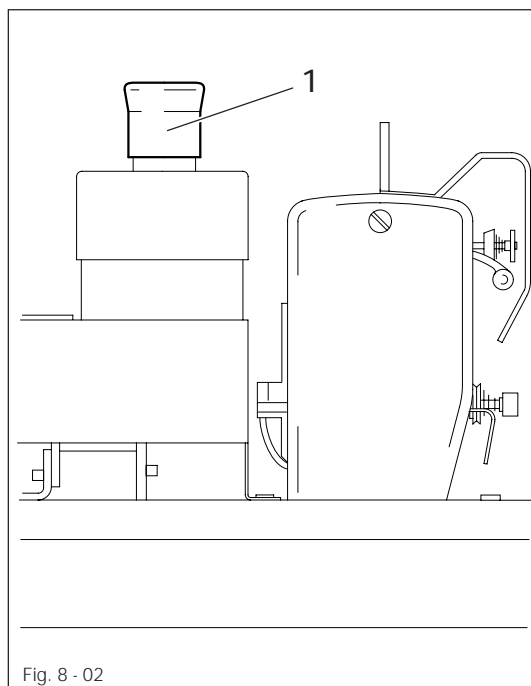

Fig. 8 - 02

- In dangerous and emergency situations, stop the machine by pressing the EMERGENCY STOP button 1. The machine is stopped by being cut off from the power supply immediately.
- The machine can be restarted by turning and pulling up the EMERGENCY STOP button 1 and subsequently switching the control back on with key 2 (see Fig. 8-01).

8.03 Pedal

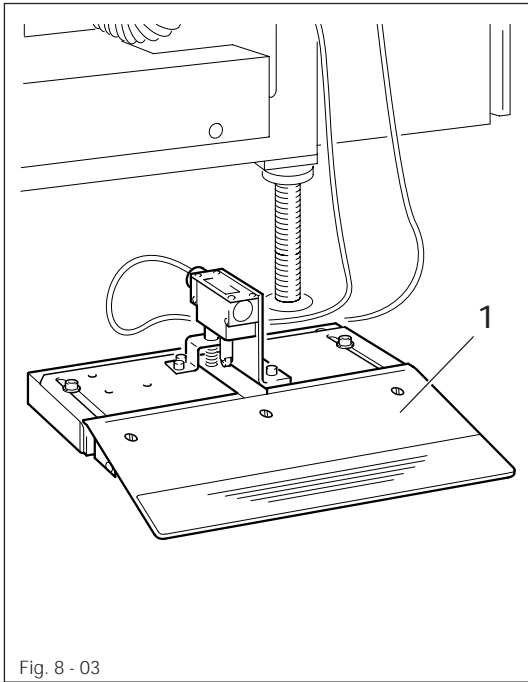

Fig. 8 - 03

- By pressing pedal 1, the vacuum for the loading table or the positioning pipe is switched on or off, depending on the position of turn switch 4 (see Fig. 8-01).

8.04 Start keys

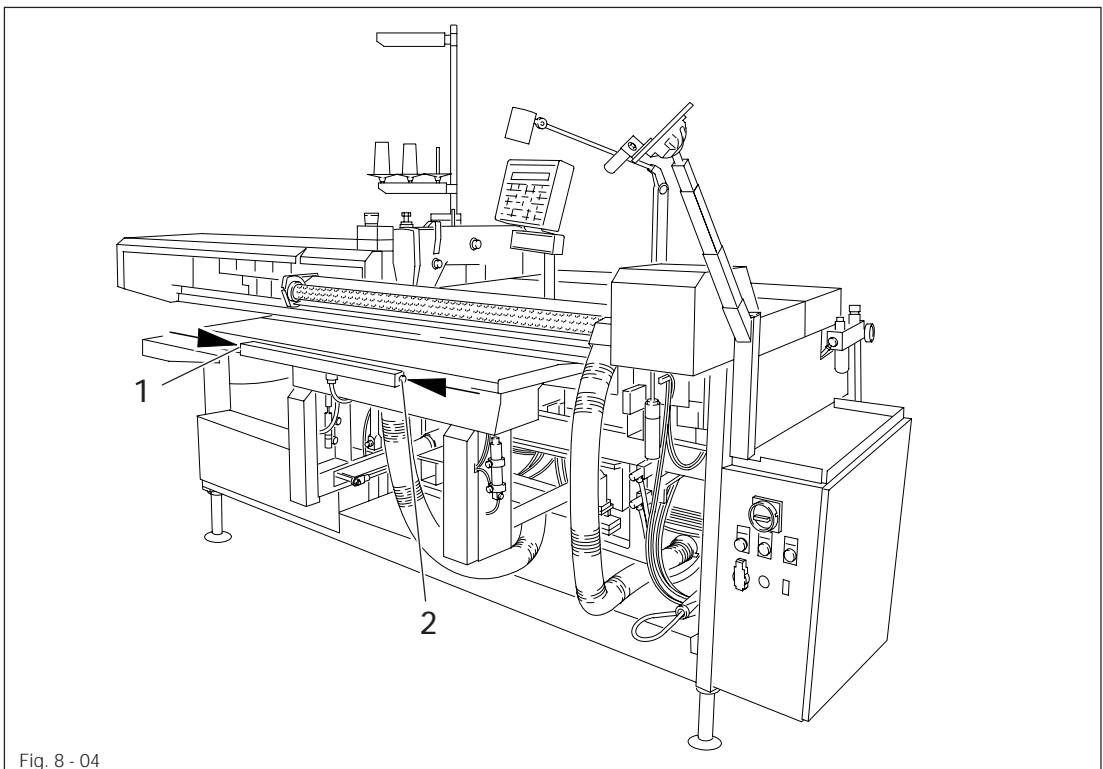
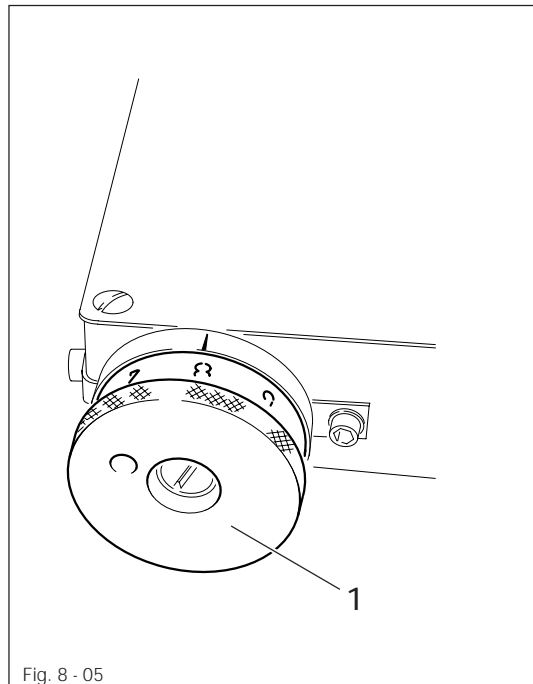

Fig. 8 - 04

- After inserting the workpiece with the vacuum switched on, start the machine by pressing keys 1 and 2 simultaneously.

8.05 Adjustment dial for dart depth



- Set the dart depth to correspond with the setting L3 shown in the display by turning adjustment dial 1 (see Fig. 8-06).

8.06 Control panel

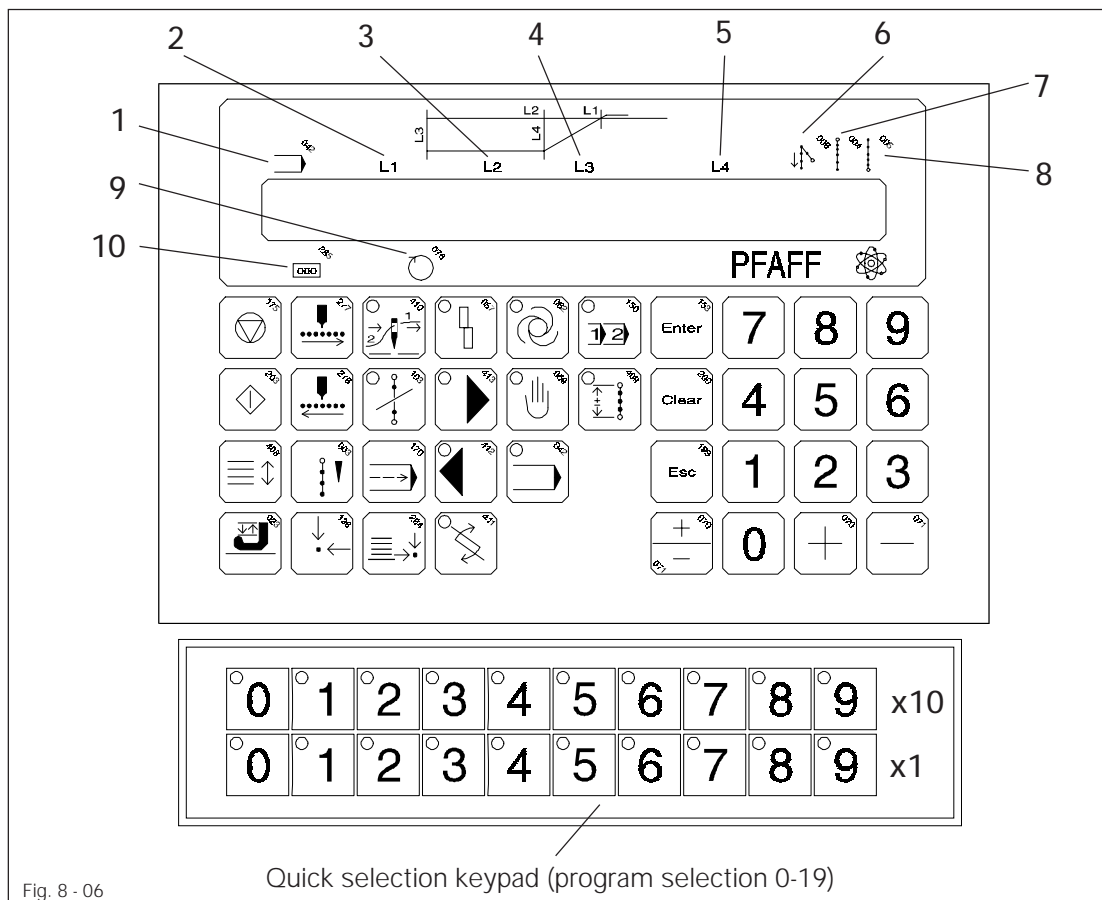

Fig. 8 - 06

Quick selection keypad (program selection 0-19)

8.06.01 Messages in the display

- 1 = Program number
- 2 = Dart length L1
- 3 = Waist point L2
- 4 = Dart depth L3
- 5 = Waist point depth L4
- 6 = Start backtack
- 7 = Start stitch condensation
- 8 = End stitch condensation
- 9 = Current speed
- 10 = Daily unit counter

8.06.02 Functions of the keys



Stop



Start



Stacker up/down



Presser foot and runner up/down



Cycle forwards through seam construction (without sewing) when  is pressed



Cycle backwards through seam construction (without sewing) when  is pressed



Start when  is pressed



Position needle / carriage to basic position, sewing and stacker to basic position



Thread (carriage and foot down) * retract table with the two START keys on the



Sewing off *



Feed forwards step by step when  is pressed



Feeding in basic position



Reset *

* = Function active, when diode is lit

Operational controls



Right jacket piece *



Left jacket piece *



Automatic change left / right jacket piece *



AUTOMATIC mode *



MANUAL mode *



INPUT mode *



Program selection *



Correction values *



Enter (confirm input)



Delete input



Delete the last input



Input "+" (roll function)



Input "-" (roll function)



Sign

* = Function active when diode is lit

9 Installation and commissioning



This machine may only be installed and commissioned by qualified specialists!
All relevant safety regulations are to be adhered to!

9.01 Unpacking and incoming materials control

After unpacking and before commissioning, check the machine for damaged caused in transit. In case of damage, inform the forwarder and the responsible PFAFF sales outlet.

9.01 Installation

Suitable connections for electrical and compressed air supplies must be available at the machine's location (see **Chapter 3 Specifications**). The machine must be mounted on a solid, horizontal surface.



Due to reasons of packaging, the reel stand is delivered dismounted. It is to be mounted when installing the machine.

9.02.01 Aligning the machine

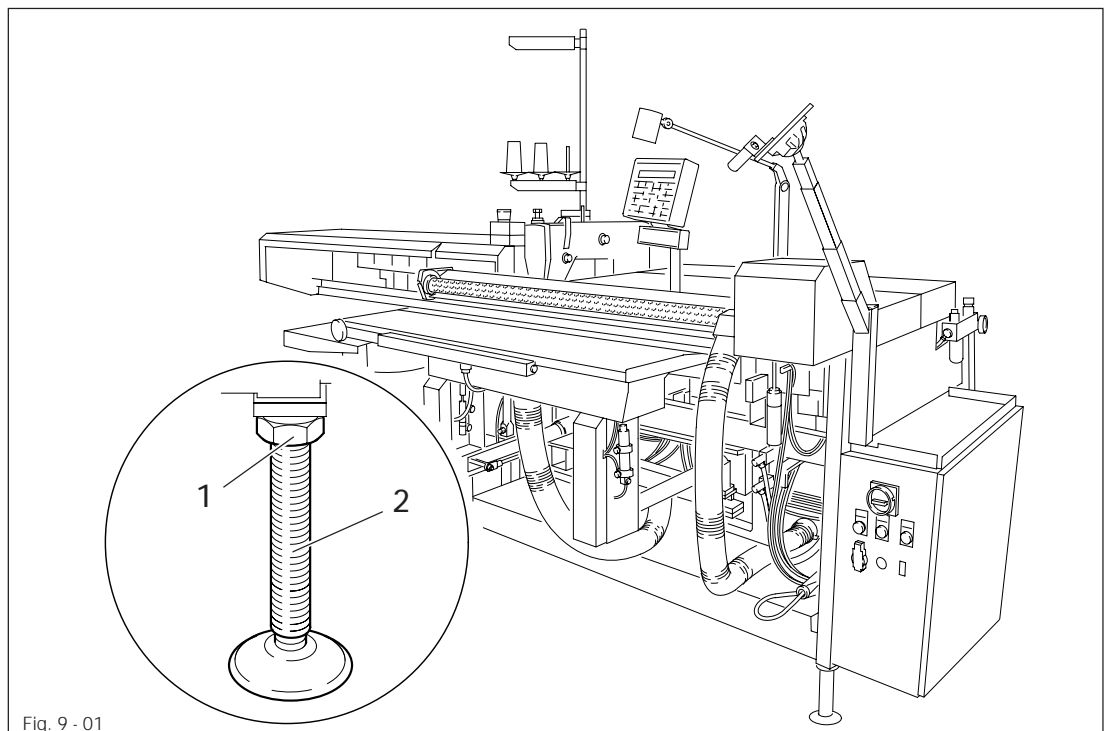
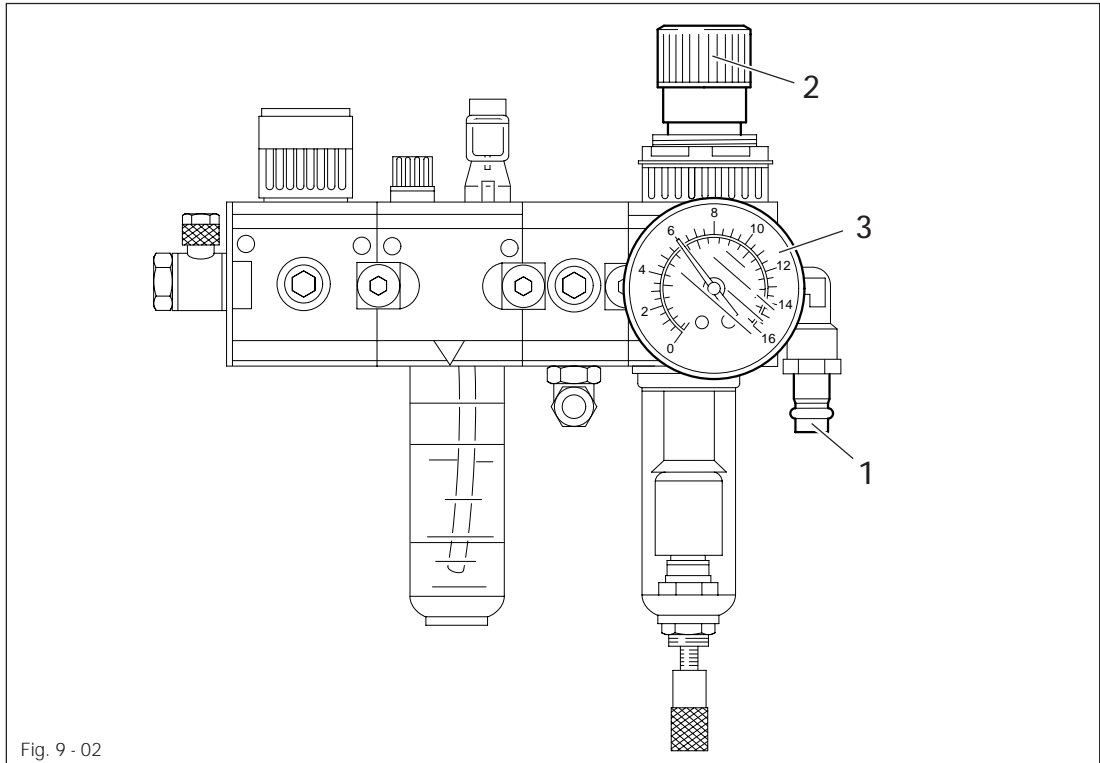

Fig. 9 - 01

- Loosen nut 1 and turn foot 2 so that the machine stands horizontally.
- Tighten nut 1.
- Check that the machine is horizontal by laying a spirit level on the lower frame bar.

Installation and commissioning

9.02.02 Connecting the compressed air system



- Connect the compressed air tube (6 mm inner diameter) of the customer's compressed air system to nozzle 1.



Minimum pressure in system: 7 bar
Working pressure: 6 bar

- Regulate the pressure by lifting and turning valve 2 so that gauge 3 displays a pressure of 6 bar.

9.02.03 Connecting the electricity supply



The machine may only be connected to the power supply if the working voltage on the specification plate and the supply voltage are the same! The machine must only be plugged into earthed electrical sockets!

9.02.04 Connecting the pedal

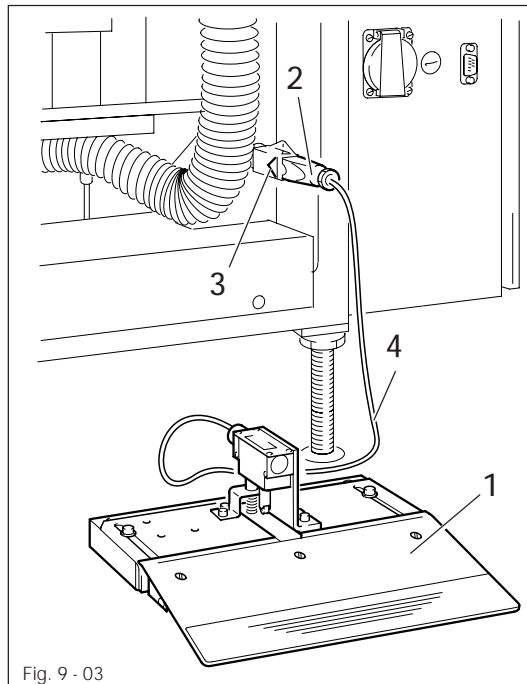

Connect pedal 1 as follows:

- Insert plug 2 into the socket.
- Secure this connection with latch 3.



Always ensure that cable 4 leading to pedal 1 is kept underneath the machine.

Danger of tripping over the cable!

If desired, affix cable 4 to the frame of the machine.

9.02.05 Connecting the vacuum motor

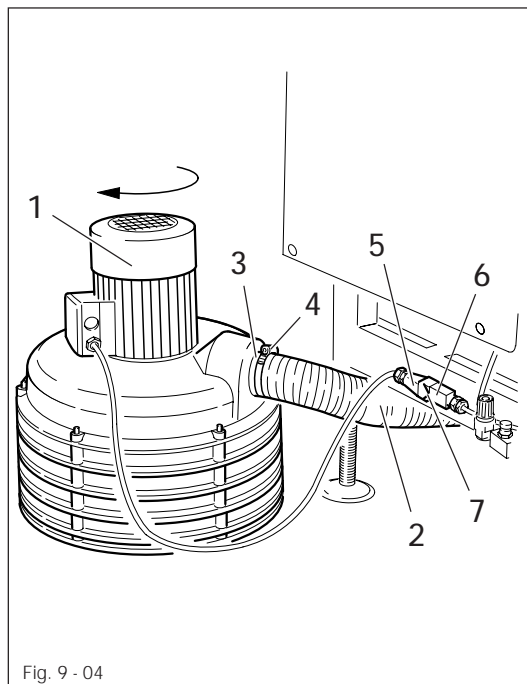

Connect vacuum motor 1 as follows:

- Slide pipe 2 over flange 3.
- Tighten clamp 4 to secure the connection.
- Insert plug 5 into socket 6.
- Use latch 7 to secure the connection.



The ventilator in the compressed air motor 1 must rotate in the direction of the arrow!

If the direction of rotation is false, have the phases in the mains plug changed by a qualified technician!

9.02.06 Installing and aligning the laser

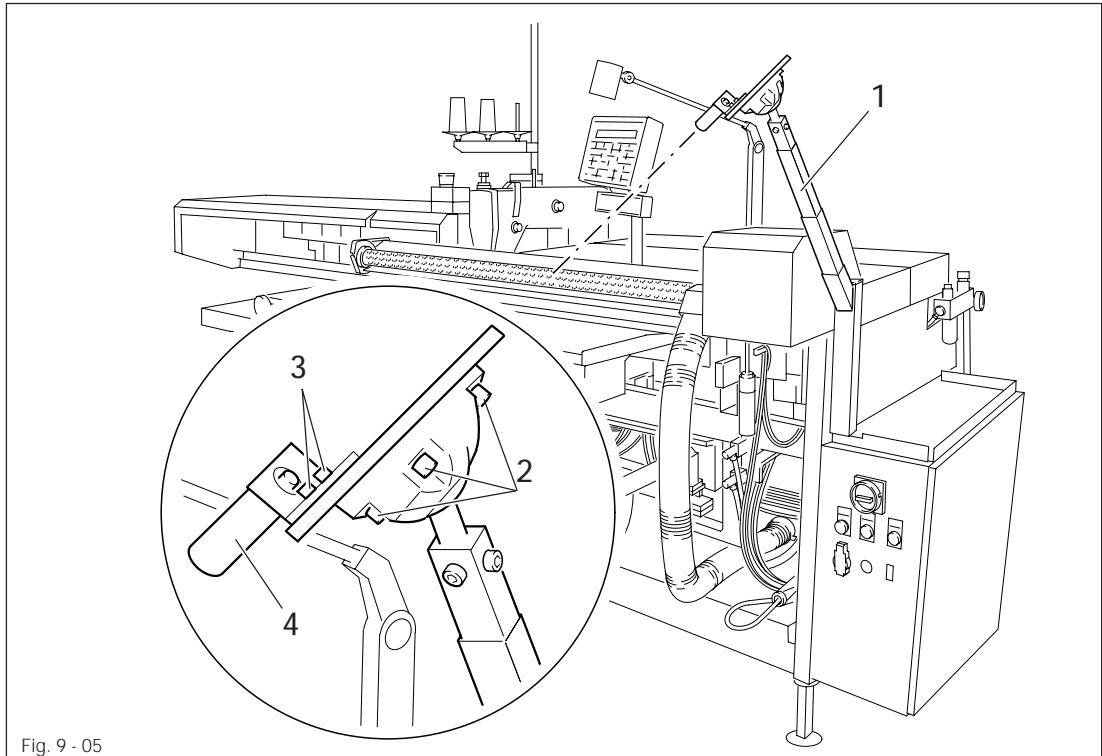

Fig. 9 - 05

- Mount carrier 1.
- Loosen screws 2 and 3 a little.
- Align laser 4 on the red marking on the positioning pipe.
- Tighten screws 2 and 3.



Do not look into the laser beam! Not even with optical devices!

9.03 Commissioning

- Check the air filter (see Chapter 13.03 Checking the air filter).
- Switch the machine on (see Chapter 8.01 On/Off switch).
- Engage the control (see Chapter 8.01 On/Off switch).
- Select the type of workpiece insertion (see Chapter 8.01 On/Off switch).
- Cycle manually through the program until sewing and check that all of the functions are carried out.

10 Switching the machine on/off

10.01 Commissioning/shutting down the machine

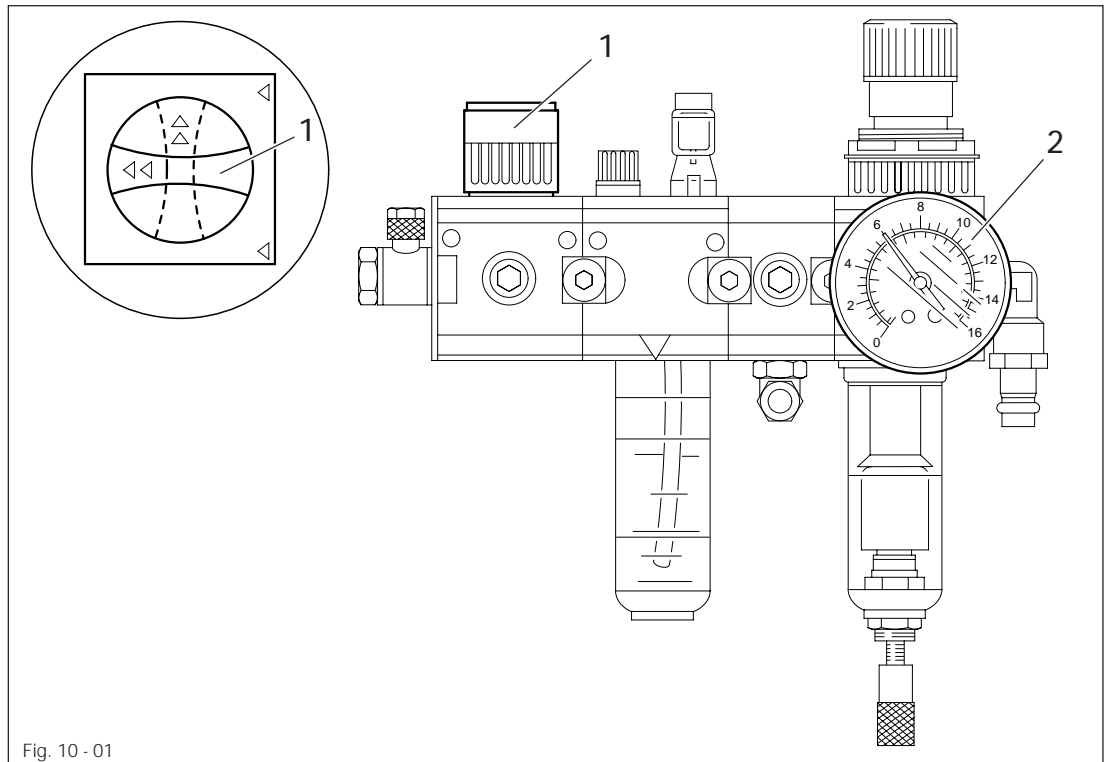

Fig. 10 - 01

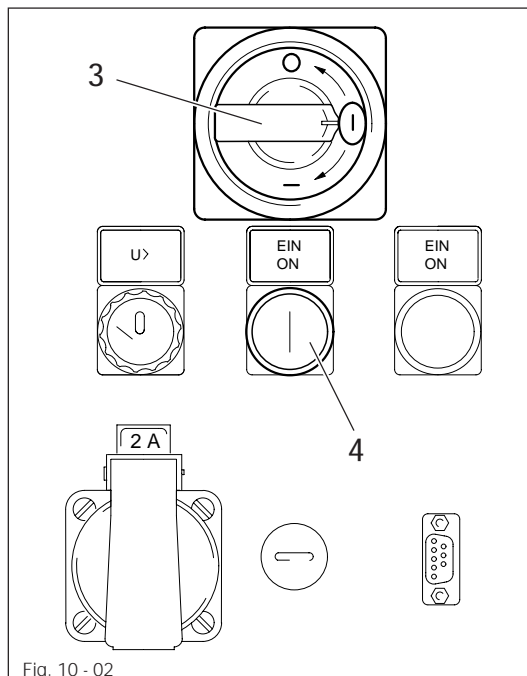

Fig. 10 - 02

Switching on:

- Open the main compressed air supply line.
- Open pressure valve 1.
- Check gauge 2 for a working air pressure of 6 bar. Adjust the air pressure if necessary as described in Chapter 9.02.02 Connecting the compressed air system.
- Turn on/off switch 3 to "1".
- Engage the control with key 4.

Switching off:

- Turn on/off switch 3 to "0".
- Close compressed air valve 1.

Switching the machine on/off

10.02 Switching the machine off in an emergency

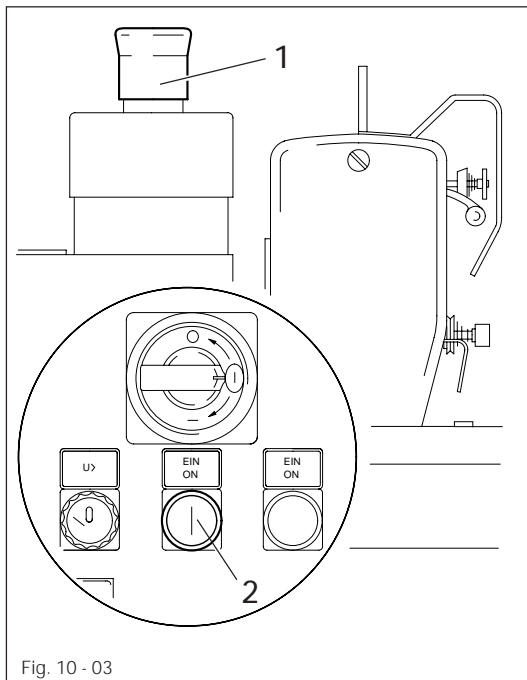

Fig. 10 - 03

- In cases of emergency or danger, stop the machine by pressing the EMERGENCY STOP button 1.

The machine is stopped immediately by cutting off the power supply to the machine.

Restarting:

- Turn and lift the EMERGENCY STOP button 1.
- Engage the control with key 2.

10.03 Interrupting the operation of the machine (in AUTOMATIC mode)

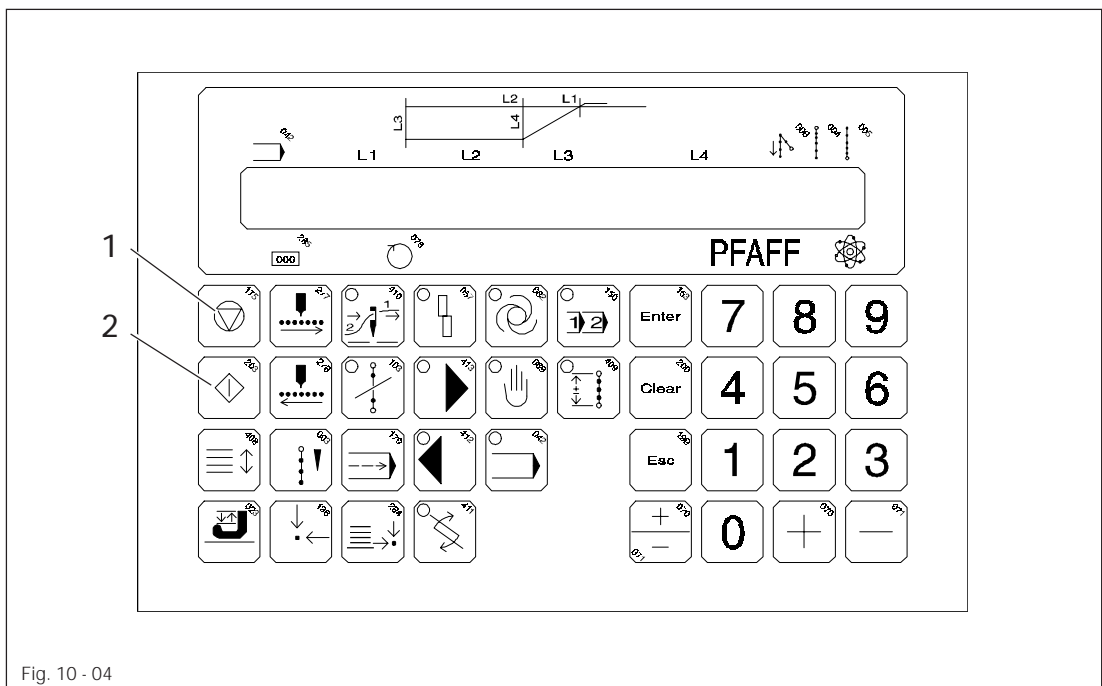



Fig. 10 - 04

Stopping the machine:

- Press key 1 = .





Starting the machine:

- Press key 2 = .

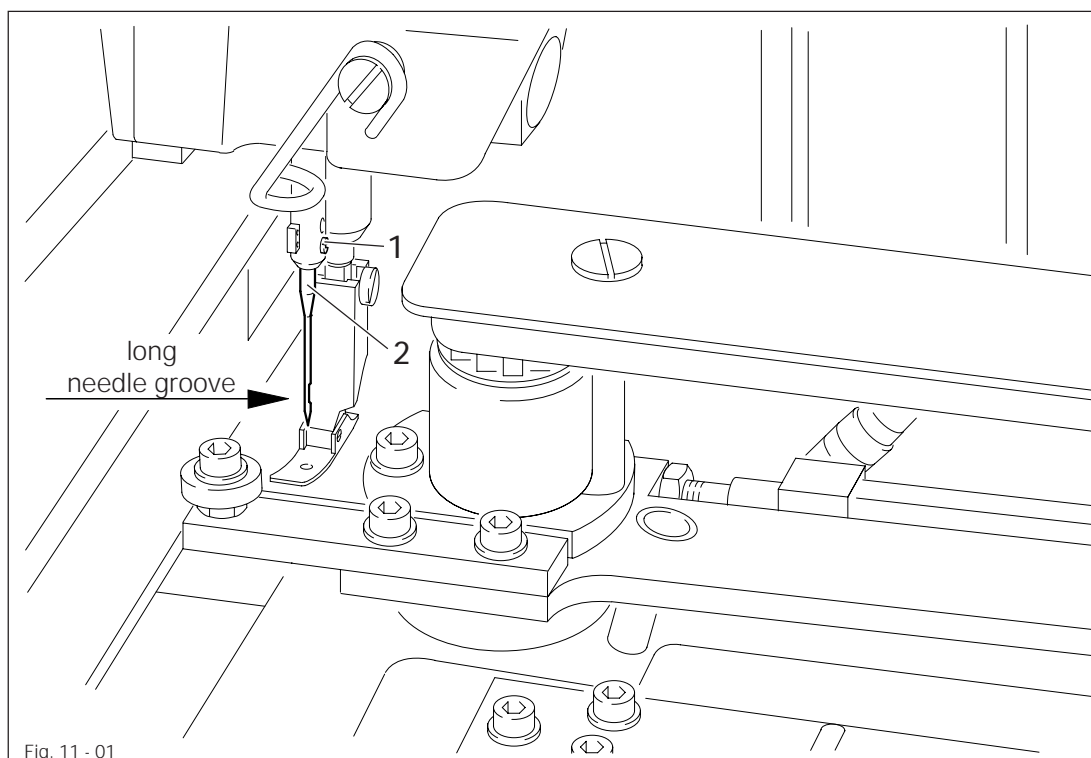
11 Preparation

11.01 Inserting the needle



- Press key  in AUTOMATIC or MANUAL mode.
The diode of key  lights up.
The workholder bar and the presser foot move downwards.
The sewing start is blocked.
- By pressing both start keys simultaneously (see Chapter 8.04 Start keys) retract the table.
- Loosen needle retaining screw 1.
- Insert the needle until you feel it stop. The long needle groove must be pointing to the left as viewed in sewing direction.
- Retighten needle retaining screw 1.
- Press key  again.
The diode of key  turns off.
The workholder bar and the presser foot move upwards.
The machine is once again ready for operation.



Attention needle! Danger of injury!

11.02 Winding the bobbin thread, adjusting the primary thread tension

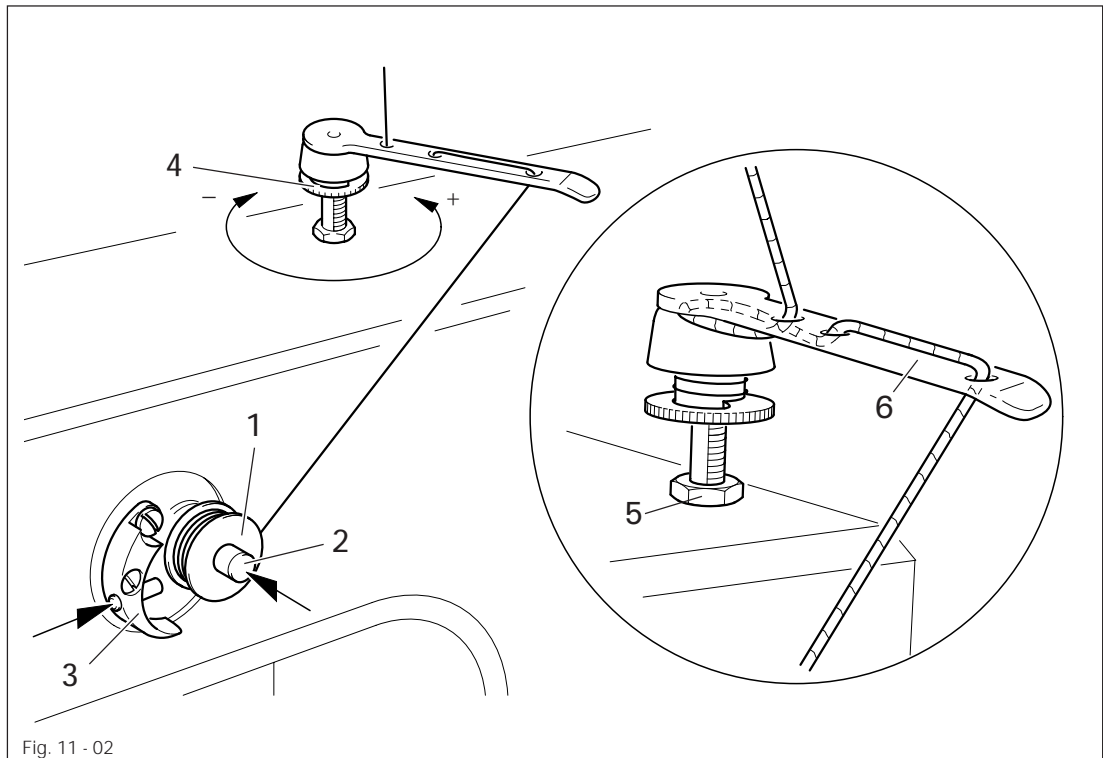

- Place an empty bobbin 1 onto bobbin winder spindle 2.
- Thread the thread in accordance with Fig. 11-02 and wind it clockwise a few times around the bobbin.
- Engage the bobbin winder by pushing bobbin winder spindle 2 and lever 3 simultaneously.



The bobbin is wound during sewing.

- The tension of the thread on bobbin 1 can be adjusted using milled screw 4.
- The bobbin winder stops automatically when bobbin 1 is full.

If the thread is wound irregularly:

- Loosen nut 5.
- Turn thread guide 6 accordingly.
- Tighten nut 5.

11.03 Changing the bobbin, threading the bobbin case and adjusting the thread tension

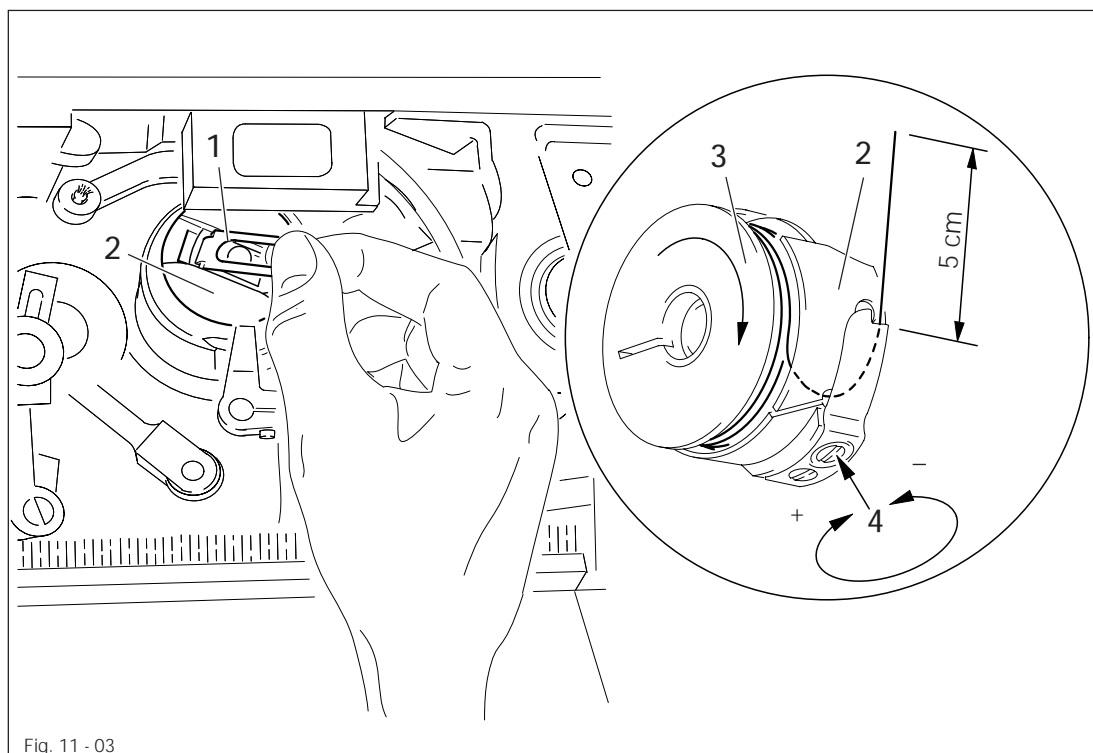

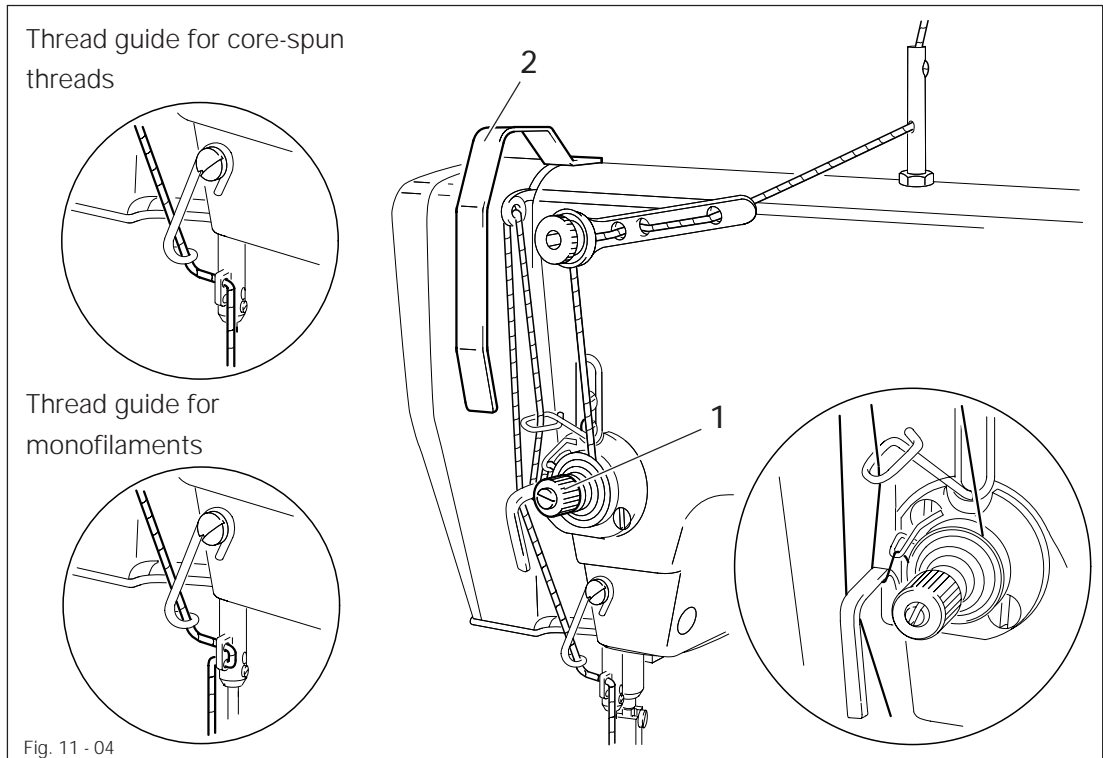

Fig. 11 - 03

- Press key  in AUTOMATIC or MANUAL mode.
The diode of key  lights up.
The workholder bar and the presser foot move downwards.
The sewing start is blocked.
- Retract the table by pressing both start keys simultaneously (see Chapter 8.04 Start keys).
- Lift latch 1 and pull out bobbin case 2.
- Insert bobbin 3 into bobbin case 2 so that it rotates in the direction of the arrow when the thread is pulled and thread the thread in accordance with Fig. 11-03.
- Adjust the thread tension by turning screw 4.
- Lift latch 1, insert bobbin case 2 with bobbin 3 into the hook in such a way that it clicks into place.

11.04 Threading the needle thread, adjusting the thread tension



- Thread the needle thread in accordance with Fig. 11-04.
- Adjust the needle thread tension by turning milled screw 1.



The thread is to be threaded through the eye of the needle from left to right!



Do not operate the machine without take-up lever guard 2!
Danger due to up and down movement of the take-up lever!

11.05 Changing the dart insert

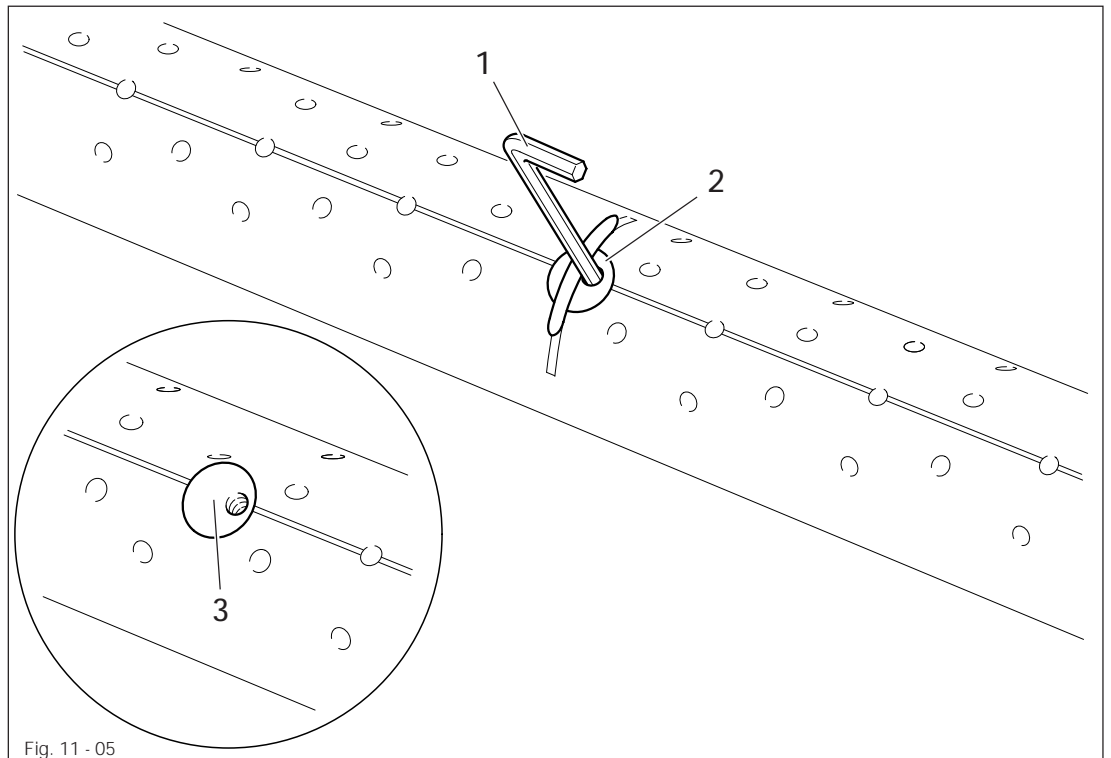

- Screw the enclosed pin 1 into the threaded hole in insert 2.
- Pull out insert 2.
- Insert a new insert in accordance with the dart depth.



Insert blind insert 3 for double pointed darts.

12 Programming and sewing

12.01 Description of the seam type

Single pointed darts

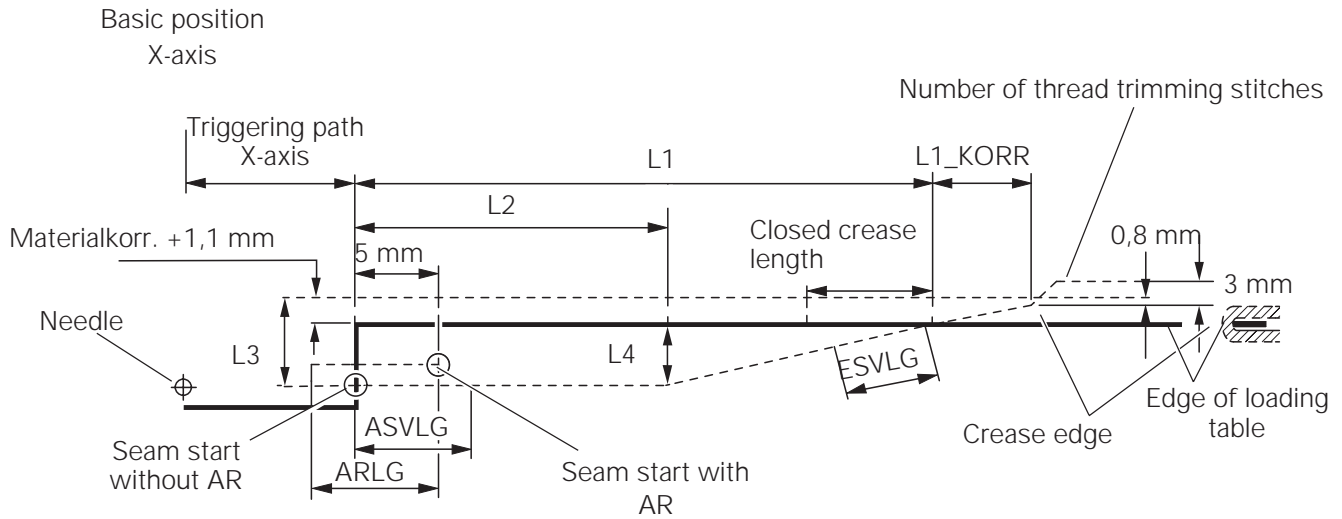

Double pointed darts

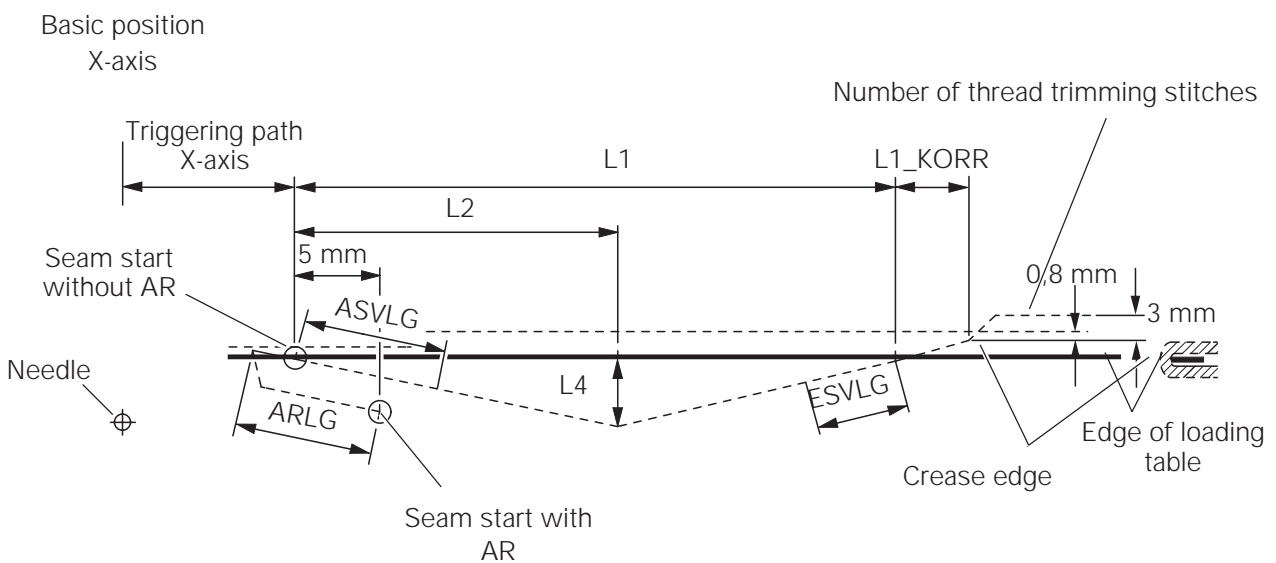













Programming and sewing

12.02.01 Menu functions

MAIN FUNCTIONS	SUBFUNCTIONS	SUBFUNCTIONS
1 - SEAM PATTERN PROGR. / CORRECTION		
2 - BASIC SETTINGS (PROGRAM)		
3 - COUNTERS	<ul style="list-style-type: none"> 1 - PIECE COUNTER 2 - BOBBIN COUNTER 3 - BOBBIN PRESELECT 4 - THREAD MONITOR DELAY 5 - BOBBIN MONITOR DELAY 6 - SLOW STARTING STITCHES 7 - THREAD TRIMMING STITCHES 8 - UNCUT FOLD LENGTH 9 - X-AXIS APPROACH PATH 	
4 - SWITCH FUNCTIONS	<ul style="list-style-type: none"> 1 - THREAD MONITOR <ul style="list-style-type: none"> 1 - THREAD MONITOR 3 - BOBBIN MONITOR 4 - BOBBIN SENSOR 2 - TACK AND STITCH CONDENSATION <ul style="list-style-type: none"> 1 - START TACK 2 - START STITCH CONDENSATION 3 - END STITCH CONDENSATION 3 - LANGUAGES <ul style="list-style-type: none"> 1 - GERMAN 2 - ENGLISH 3 - FRENCH 4 - SPANISH 5 - ITALIAN 4 - OTHER FUNCTIONS <ul style="list-style-type: none"> 1 - FEED DOG LOWERING 2 - FEEDER FOR PRESS BACKING 	
5 - TIMES		
6 - SEWING SPEEDS	<ul style="list-style-type: none"> 1 - START SPEED (TACK / STITCH COND.) 2 - MAXIMUM SPEED 	
7 - PROGRAM MANAGEMENT	<ul style="list-style-type: none"> 1 - PROGRAM DIRECTORY <ul style="list-style-type: none"> 1 - MEMORY DIRECTORY 2 - DISK DIRECTORY 2 - READ PROGRAM FROM DISK <ul style="list-style-type: none"> 1 - READ ONE PROGRAM FROM DISK 2 - READ ALL PROGRAMS FROM DISK 3 - WRITE PROGRAM ON DISK <ul style="list-style-type: none"> 1 - WRITE ONE PROGRAM ON DISK 2 - WRITE PROGRAM SECTION ON DISK 4 - DELETE PROGRAM <ul style="list-style-type: none"> 1 - DELETE ONE PROGRAM (MEMORY) 2 - DELETE PROGRAM SECTION (MEMORY) 3 - DELETE ONE PROGRAM (DISK) 4 - DELETE ALL PROGRAMS (DISK) 5 - FORMAT DISK 	
8 - SERVICE	<ul style="list-style-type: none"> 1 - SEWING MOTOR 2 - STEPPING MOTOR X - AXIS 3 - STEPPING MOTOR Y - AXIS 4 - THREAD TRIMMING SEQUENCE 5 - DISPLAY INPUTS 6 - SET / RESET OUTPUTS 7 - ALTERATION OF STITCH LENGTH 	

12.02.02 Description of the menus

- 1- SEAM PATTERN PROGR. / CORRECTION
- 2- BASIC SETTINGS (PROGRAM)
- 3- COUNTERS
 - 1- PIECE COUNTER
Informs about the current daily production.
Maximum display value = 65565.
Value can be returned to "0" with  key.
Return to „0“ is automatic when the maximum display value is exceeded.
 - 2- BOBBIN COUNTER
Informs about the current number of stitches sewn.
Value can be returned to "0" with  key.
When set value has been reached (see -3- bobbin thread setting), CHANGE BOBBIN appears and counter returns to "0" automatically.
 - 3- BOBBIN PRESELECT
When the bobbin thread monitor is switched on, the machine stops at the end of the seam construction for the bobbin change, when the set number of stitches is reached.
When this function is called up, the set value is displayed.
A new value can be entered with the  and  keys or the number keys.
 - 4- THREAD MONITOR DELAY
Speed setting when starting sewing until thread monitor is active.
When this function is called up, the set value is displayed.
A new value can be entered with the  and  keys or the number keys.
 - 5- BOBBIN MONITOR DELAY
Same function as for -4-
 - 6- SLOW STARTING STITCHES
Number of slow start stitches for a reliable sewing start.
When this function is called up, the set value is displayed.
A new value can be entered with the  and  keys or the number keys.
 - 7- THREAD TRIMMING STITCHES
Number of thread cutting stitches before the seam end.
When this function is called up, the set value is displayed.
A new value can be entered with the  and  keys or the number keys.



- 8- UNCUT FOLD LENGTH
Length of the crease which is not to be cut in the direction of the dart point.
When this function is called up, the set value is displayed.
A new value can be entered with the  and  keys or the number keys.

- 9- X-AXIS APPROACH PATH
When this function is called up, the set value is displayed.

-4- SWITCH FUNCTIONS



-1- THREAD MONITOR

- 1- THREAD MONITOR
- 2- BOBBIN MONITOR
- 3- BOBBIN SENSOR

When this function is called up, the current values are displayed.
Each element can be switched on with key  and off with key .



-2- TACK AND STITCH CONDENSATION

- 1- START TACK
- 2- START STITCH CONDENSATION
- 3- END STITCH CONDENSATION

Independent of the program, values can be inputted and selected. Each of the functions can be switched on with the  key and off with the  key or switched to the program with .

When switching the function off, this is also true when the function is on in the program.

The same is true when switching the function on.

When switching on, the parameters involved (e.g. start backtack length) can be entered with keys  and  or the number keys.

If the function is switched to program, the settings and values of the program are valid.

-3- LANGUAGES

- 1- GERMAN
- 2- ENGLISH
- 3- FRENCH
- 4- SPANISH
- 5- ITALIAN

When this function is called up, the language in which the messages in the display are to be shown can be selected.

-4- OTHER FUNCTIONS

-1- FEED DOG LOWERING

Sewing without the function of the vibrating presser can be switched on with key **1** and off with key **0**.

-2- FEEDER FOR PRESS BACKING

The optimum feed for the retainer alignment can be switched on with the **1** key and off with the **0** key.

-5- TIMES

Has no subfunctions to date.

-6- SEWING SPEEDS

-1- START SPEED (TACK / STITCH COND.)

-2- MAXIMUM SPEED

When this function is called up, the set speeds are displayed.

New values can be entered with the **+** and **-** keys or the number keys.

-7- PROGRAM MANAGEMENT

-1- PROGRAM DIRECTORY

-1- MEMORY DIRECTORY

-2- DISK DIRECTORY

The program number starting at which the following programs are to be displayed, must be entered into the memory index.

All the existing programs are displayed in the index of a disk. If one line is insufficient for displaying all the programs the display can be continued with **Enter**. The list from the memory is finished with XXXXXX BYTES FREE.

The list from the disk is finished with END.

Once all the programs have been displayed, pressing **Enter** starts the list from the beginning again.

-2- READ PROGRAM FROM DISK

-1- READ ONE PROGRAM FROM DISK

-2- READ ALL PROGRAMS FROM DISK

Select the program number with **+**, **-** and **Enter** or the number keys.



-3- WRITE PROGRAM ON DISK

-1- WRITE ONE PROGRAM ON DISK

-2- WRITE PROGRAM SECTION ON DISK

It is possible to write a program with **+**, **-** and **Enter** or with the number keys. When writing a program section, the start and stop nos. must be entered.

- 4- DELETE PROGRAM
 - 1- DELETE ONE PROGRAM (MEMORY)
 - 2- DELETE PROGRAM SECTION (MEMORY)
 - 3- DELETE ONE PROGRAM (DISK)
 - 4- DELETE ALL PROGRAMS (DISK)

Selecting the program number or the program section is possible with ,  and  or the number keys.

If all of the programs on a disk are to be deleted, press  to confirm.

- 5- FORMAT DISK
A new disk can be formatted. Disk format: 730 KB



Formatting a disk deletes all of the data on the disk!

- 8- SERVICE
 - 1- SEWING MOTOR
 - 2- STEPPING MOTOR X-AXIS
 - 3- STEPPING MOTOR Y-AXIS
 - 4- THREAD TRIMMING SEQUENCE
 - 5- DISPLAY INPUTS
 - 6- SET / RESET OUTPUTS
 - 7- ALTERATION OF STITCH LENGTH







The service functions are only for the mechanic.



For a detailed description see the service manual for the control of the PFAFF 3519-3/12.

12.02.03 Moving amongst the menu functions

You can move through the main functions with  and .

You can access the subfunction level of the selected main function with  or by directly inputting the applicable function number via the number keys  to .

You can also move through the subfunctions with  and .

The selection of the subfunction is also made with  or by directly inputting the applicable function number via the number keys  to .

With  selected functions can be interrupted.

The machine automatically skips back to the previous function.

12.02.04 Writing a program

  Display: CHOOSE FUNCTION OR SCROLL #300

  1 Display: WHICH PROGRAM NUMBER : #320

Enter the new program number with the number keys

  Cursor  jumps to L1 = dart length

Enter value L1 with the number keys = dart length

  Cursor  jumps to L2 = waist point



Enter value L2 with the number keys = waist point



  Cursor  jumps to L3 = dart depth

Enter value with the number keys L3 = dart depth

  Cursor  jumps to L4 = waist depth

Enter value with the number keys L4 = waist depth

  Display: BACKTACK FUNCTION
The backtack form need not be inputted.

Input the program number with the number keys.

  or   machine is ready for operation.

12.02.05 Altering an existing program

  Display: CHOOSE FUNCTION OR SCROLL #300

  Display: WHICH PROGRAM NUMBER #320



Using the number keys, enter the number of the program to be altered

  repeatedly until the cursor  is at the value L1-L4 which is to be altered.

Alter the value with the number keys

  or   the machine is ready for operation.

12.02.06 Correction values

-  Possible seam before correction
-  Possible seam after correction
-  Inside of material (sewing side)

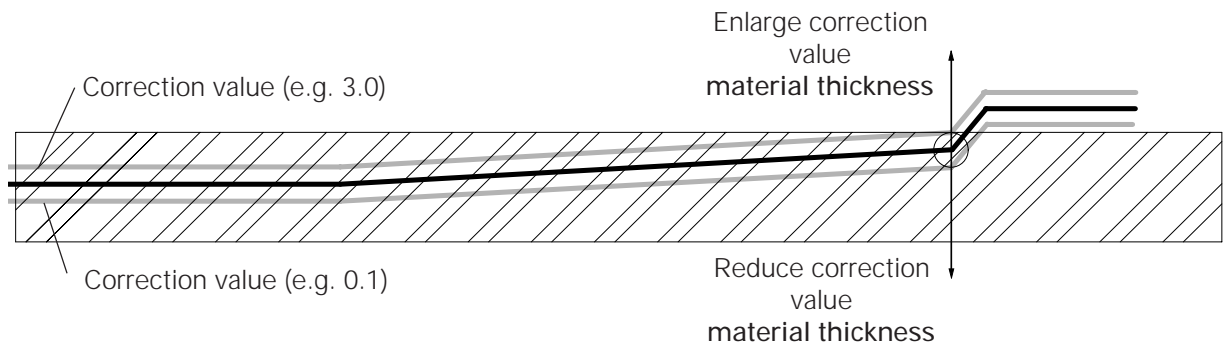

The point of the dart and the dart depth (L3 and L4) are altered with the correction value material thickness.

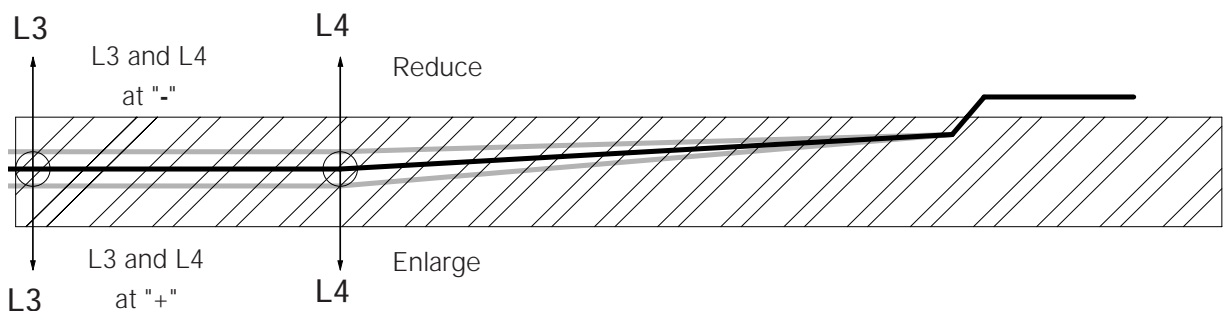



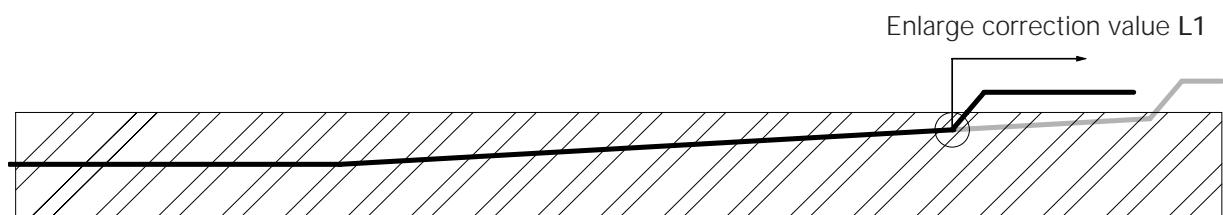









Only the dart depth is altered with the correction values L3 and L4, not the point of the dart.









12.02.07 Returning the daily unit counter to "0"

The daily unit counter is to be returned to "0" either at the end or the beginning of a working day.

-   Display: CHOOSE FUNCTION OR SCROLL #300
-   Display: COUNTERS #360
-   Display: PIECE COUNTER: RESET: CLEAR #371
-   Unit counter returns to "0"
-   or  , machine is ready for operation

12.02.08 Altering the bobbin thread setting

-   Display: CHOOSE FUNCTION OR SCROLL #300
-   Display: COUNTERS #360
-   Display: BOBBIN PRESELECT #363

Enter the new value with the number keys. The higher the value entered, the more parts can be sewn with one full bobbin.





-   or  , machine is ready for operation

12.02.09 Error messages in the display





Display: CHANGE BOBBIN #112

-  
-   Wiper 111 lowers





- Retract table (press start keys on table simultaneously).
- Change bobbin.

-   or  , machine is ready for operation

Display: THREAD ERROR #111

-  
-   presser foot and runner move down

- Retract table (press start keys on table simultaneously).
- Thread the machine.

-   or  , machine is ready for operation

Display: THREAD ERROR / CHANGE BOBBIN

#113



Wiper 111 lowers

- Retract table (press start keys on table simultaneously).
- Change bobbin.



or



machine is ready for operation

12.02.10 Program change

Using the fast selection key panel select (0-19)

or:



Enter a new program number with the number keys



or



machine is ready for operation

12.03 Sewing



The machine may only be operated by appropriately trained personnel! It is the responsibility of the operating personal to ensure that only authorized persons enter the potentially dangerous area around the machine!

- Select a program.
- Set the dart depth corresponding to the L3 value (see **Chapter 8.05 Adjustment dial for dart depth**).
- Insert an insert into the positioning pipe corresponding to the depth of the dart (see **Chapter 12.04 Inserting the workpiece**).
- Press the pedal.
- Press the start key until the positioning pipe is touching.



The machine can be reloaded while it is sewing.

12.04 Inserting the workpiece

12.04.01 Inserting the the workpiece with the positioning pipe

Loading with the positioning pipe is suitable for single and double pointed darts on monocoloured, striped or checked materials.
Stripes and checks can be aligned with the laser beam.



Do not look into the laser beam!

Single pointed darts

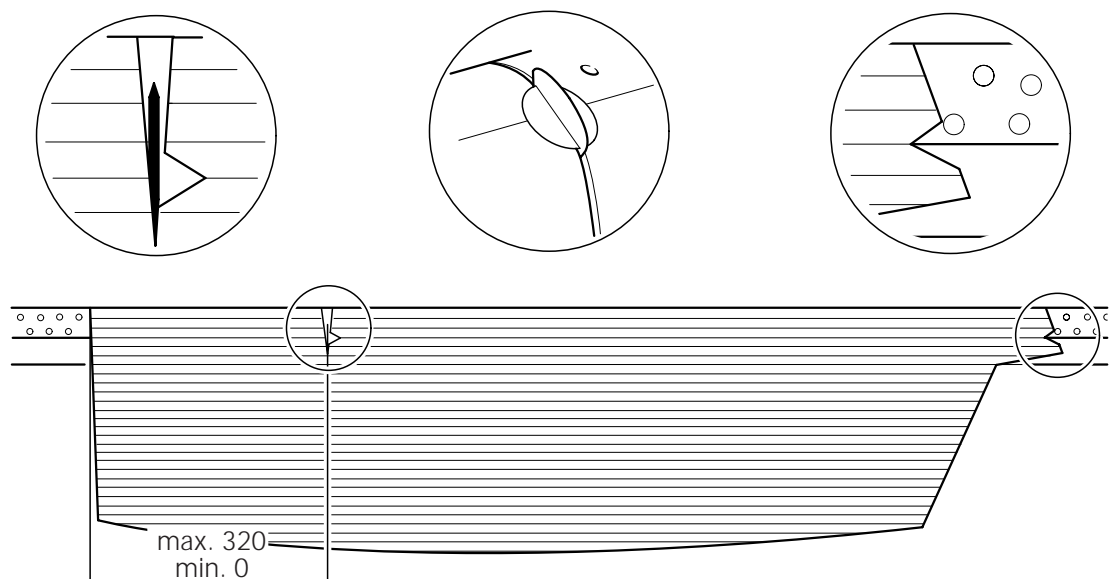
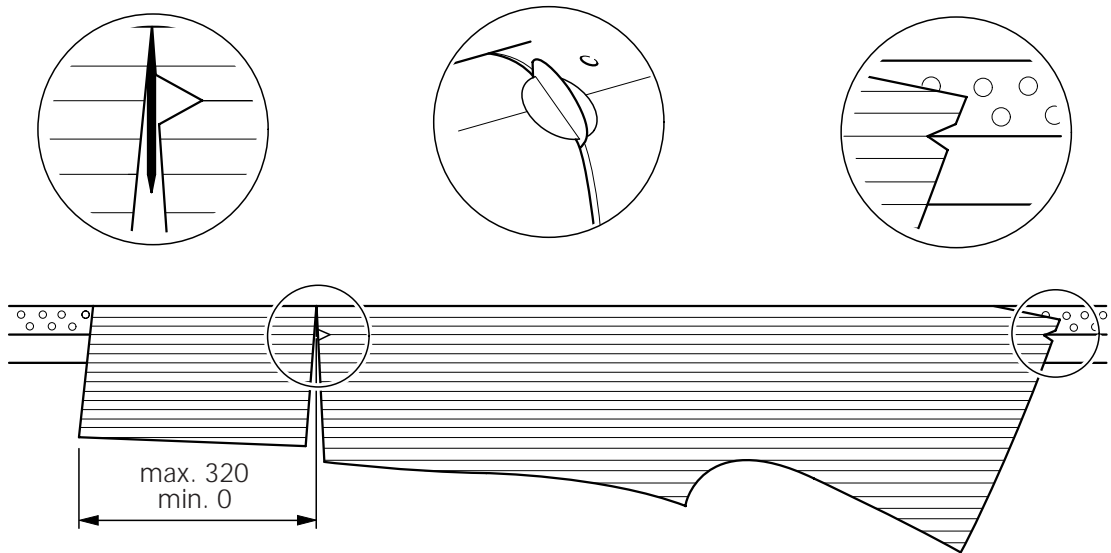

Double pointed darts

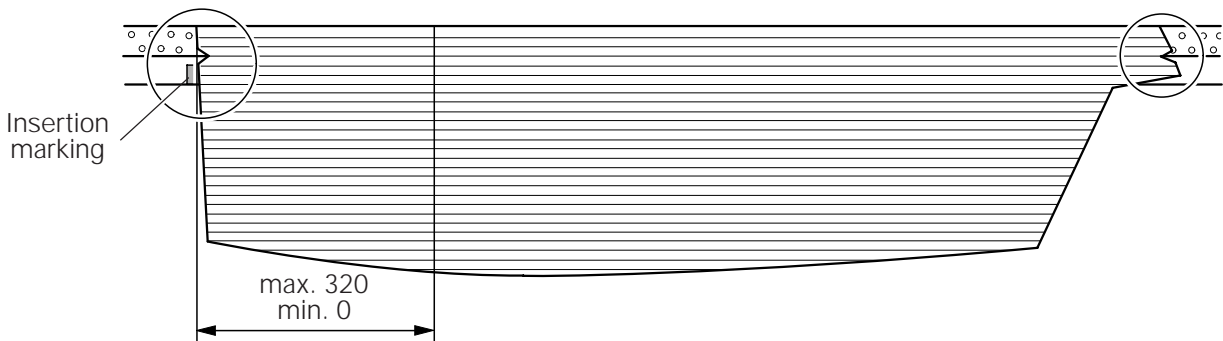
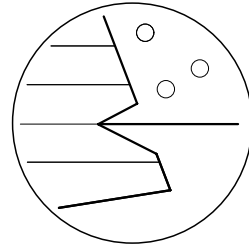
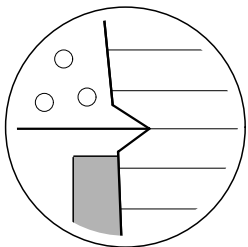
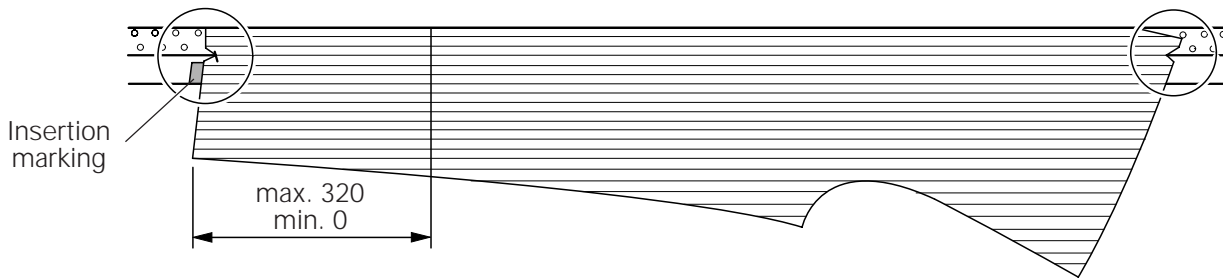
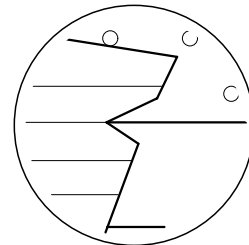
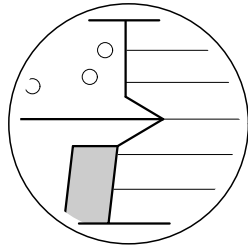

12.04.02 Inserting the workpiece with the loading table

Double pointed darts

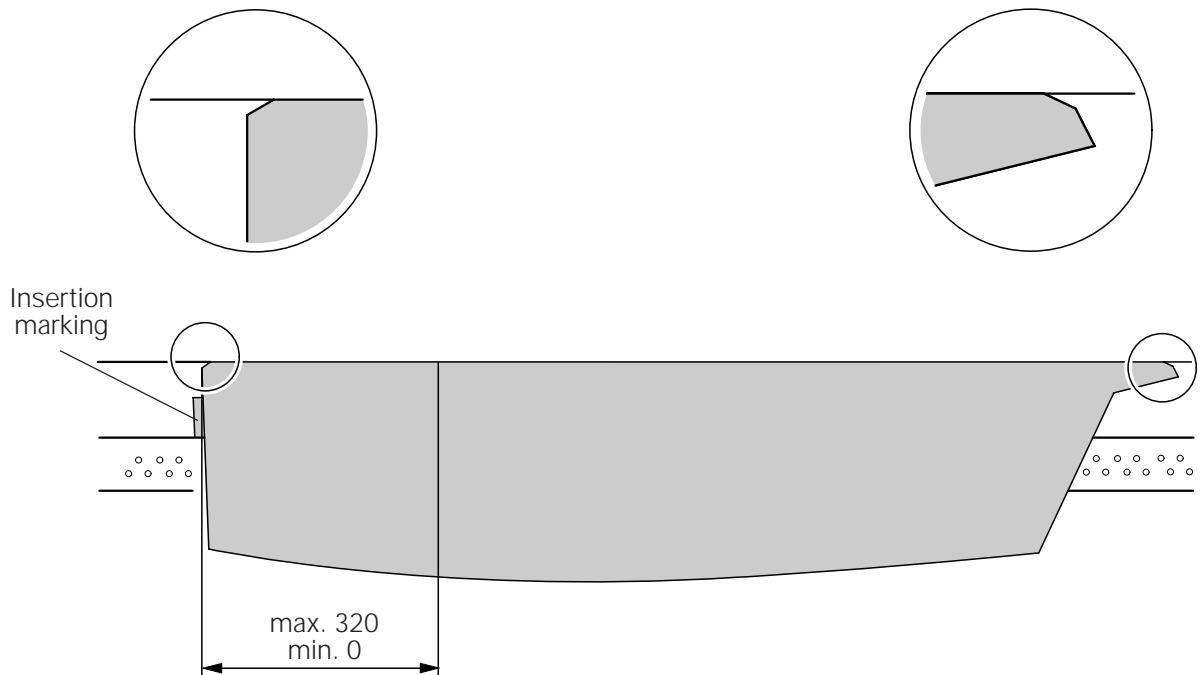
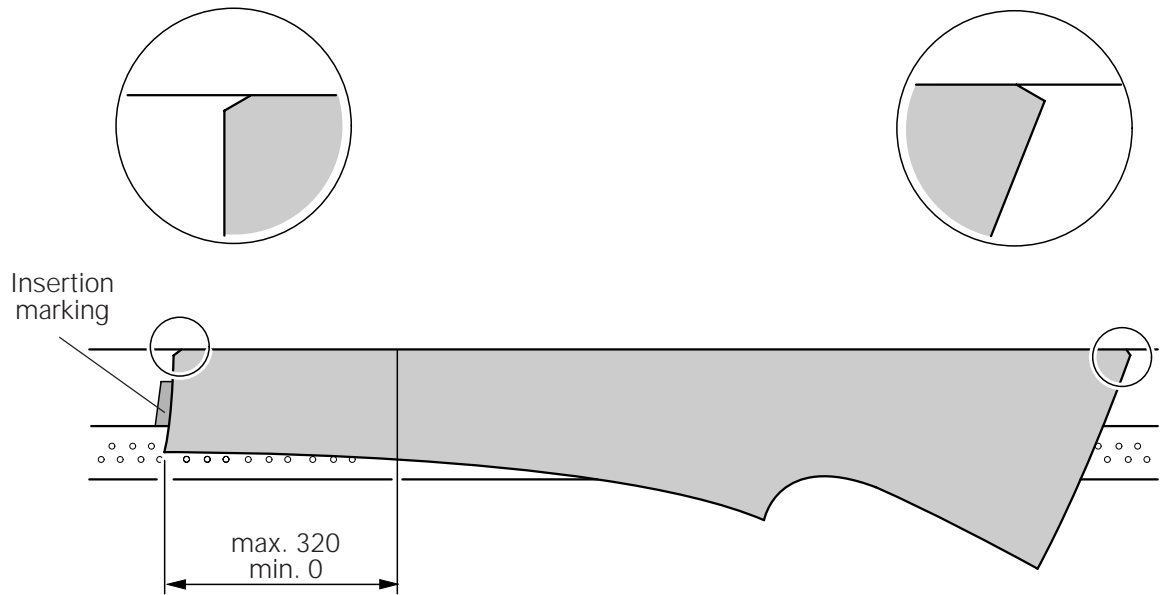

13 Care and maintenance

Cleaning the entire machine	weekly
Cleaning the needle and cutting area	daily
Cleaning the hook and hook race	daily
Lubricating the cutter	daily
Checking the air filter	daily before use
Adjusting the air pressure	as required
Topping up the oil	as required
Emptying the water container	as required
Cleaning the air filter	as required
Adjusting the drip feed rate on the oil vaporizer	as required
Cleaning the vaporizer jet	as required
Lubricating the cylinder for the runner	every 90 workdays
Checking the oil level for the sewing machine	every 9 months
Topping up the oil for the sewing machine	as required



The above mentioned maintenance intervals are valid for machines working one 8 hour shift per day. In the case of multi shift operation, these intervals are to be altered appropriately after discussion with the company maintenance staff.

13.01 Cleaning

The required cleaning cycle for the sewing machine is dependent on the following factors:

- Single or multi shift operation
- Varying dust collection due to different fabrics

The perfect cleaning instructions can only be determined for each individual machine in co-operation with the company maintenance staff and the authorized service personnel, taking into account the above factors and this manual.

13.01.01 Cleaning the entire machine

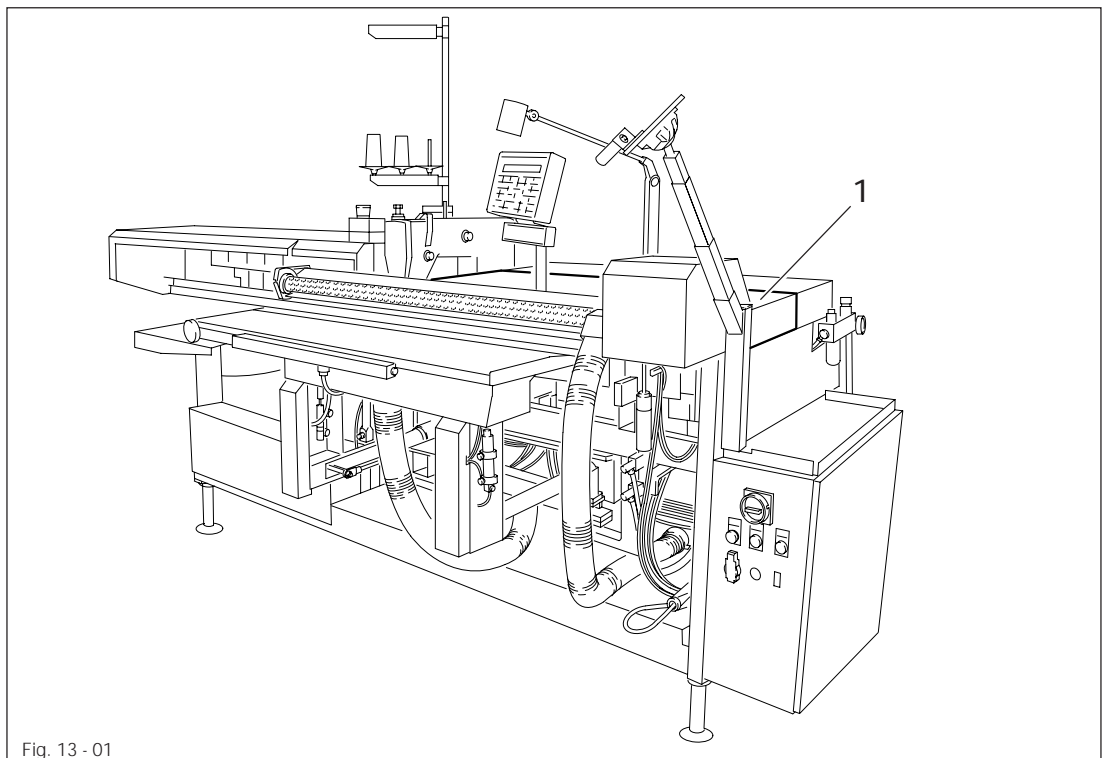

To avoid operation disturbances, we recommend the following cleaning work for a machine in single shift operation:

- Open cover 1.
Sewing start is blocked.
- Clean the needle and cutting area daily.
- Clean the entire machine at least once a week.
- Close cover 1.
The machine is once again ready for operation.

13.01.02 Cleaning the hook and the hook race

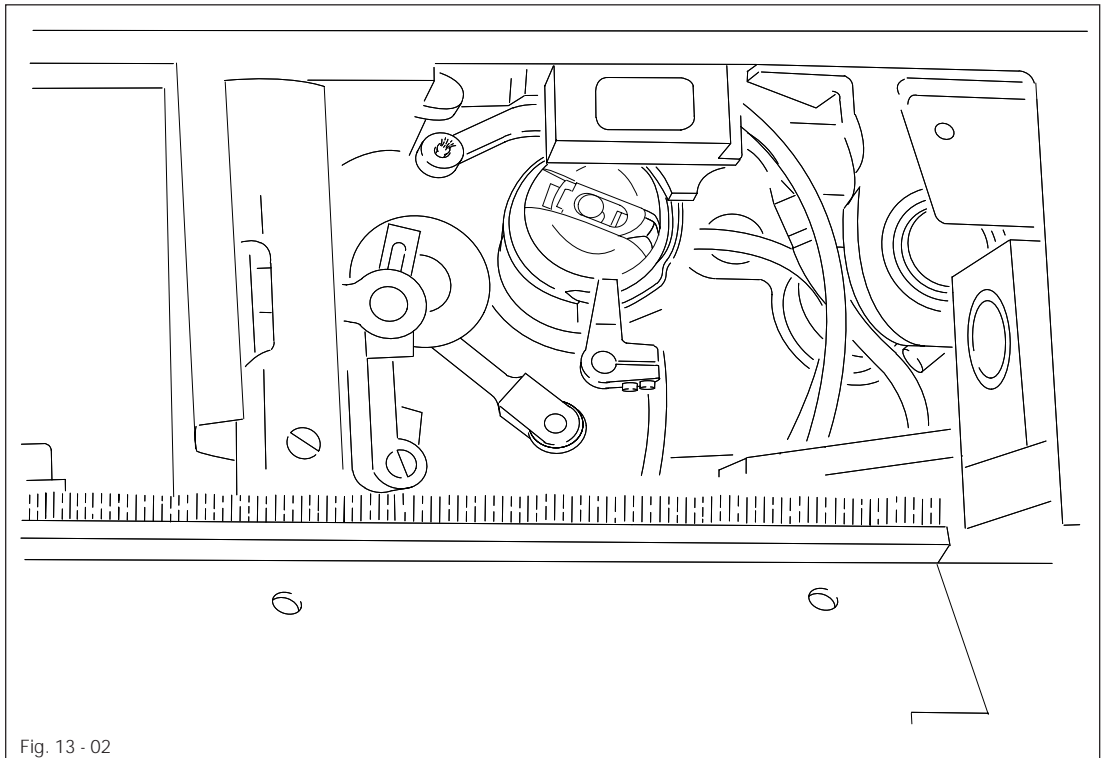

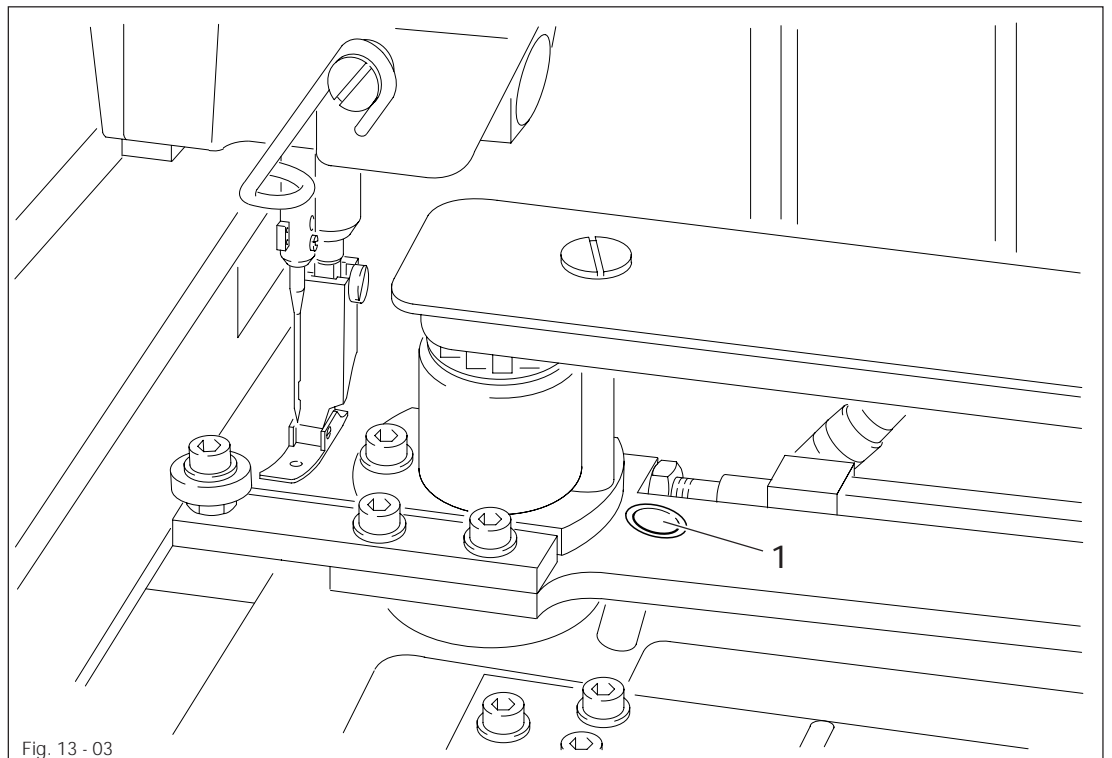

Fig. 13 - 02



- Press key  in AUTOMATIC or MANUAL mode.
Sewing start is blocked.
- Retract the table by pressing both start keys simultaneously (see **Chapter 8.04 Start keys**).
- Clean the hook and hook race daily.
- Press  again.
The machine is once again ready for operation.

13.02 Lubricating the cutter



- Squeeze 1 drop of silicon oil through hole **1** in the cutter before each use of the machine.



Only use oil with a density of 0.810 g/cm^3 at 21°C !



We recommend PFAFF sewing machine oil. Part no. 280-1-120 217.

13.03 Checking the air filter

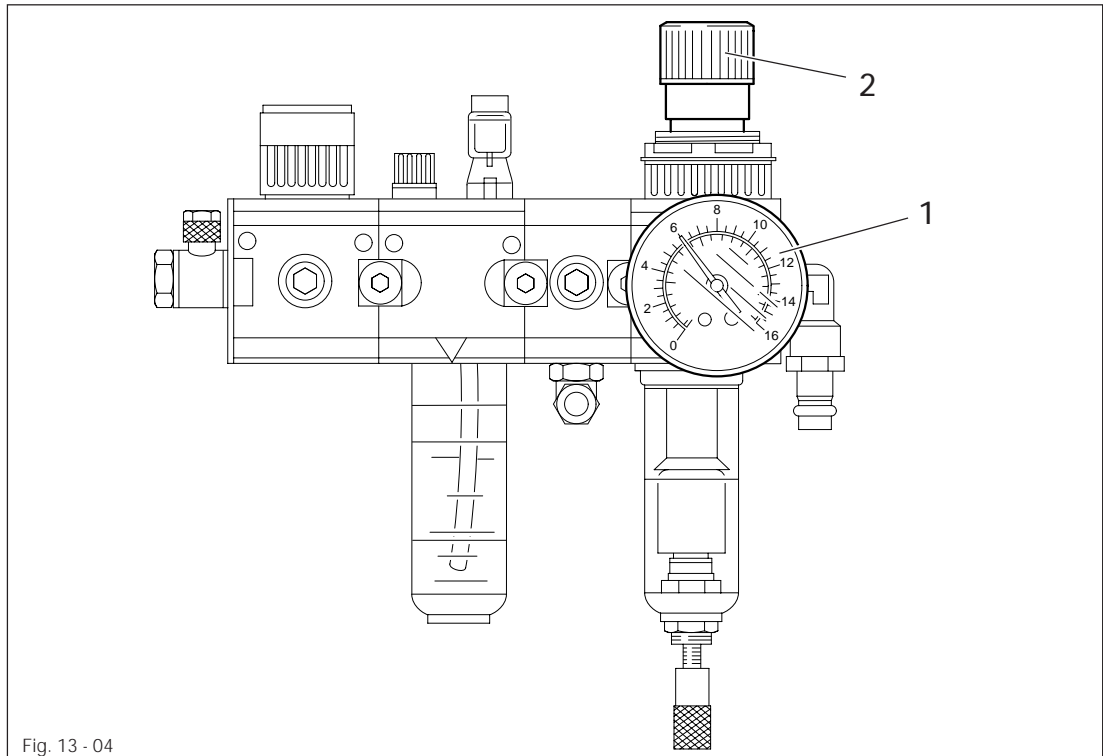

Fig. 13 - 04

13.03.01 Checking and adjusting the air pressure (Fig. 13-04)

- Check the air pressure in gauge 1 before every use.



Gauge 1 must display a pressure of 6 bar.

If required:

- Pull button 2 up and turn it until gauge 1 displays a pressure of 6 bar.

13.03.02 Checking and topping up the oil level (Fig. 13-05)

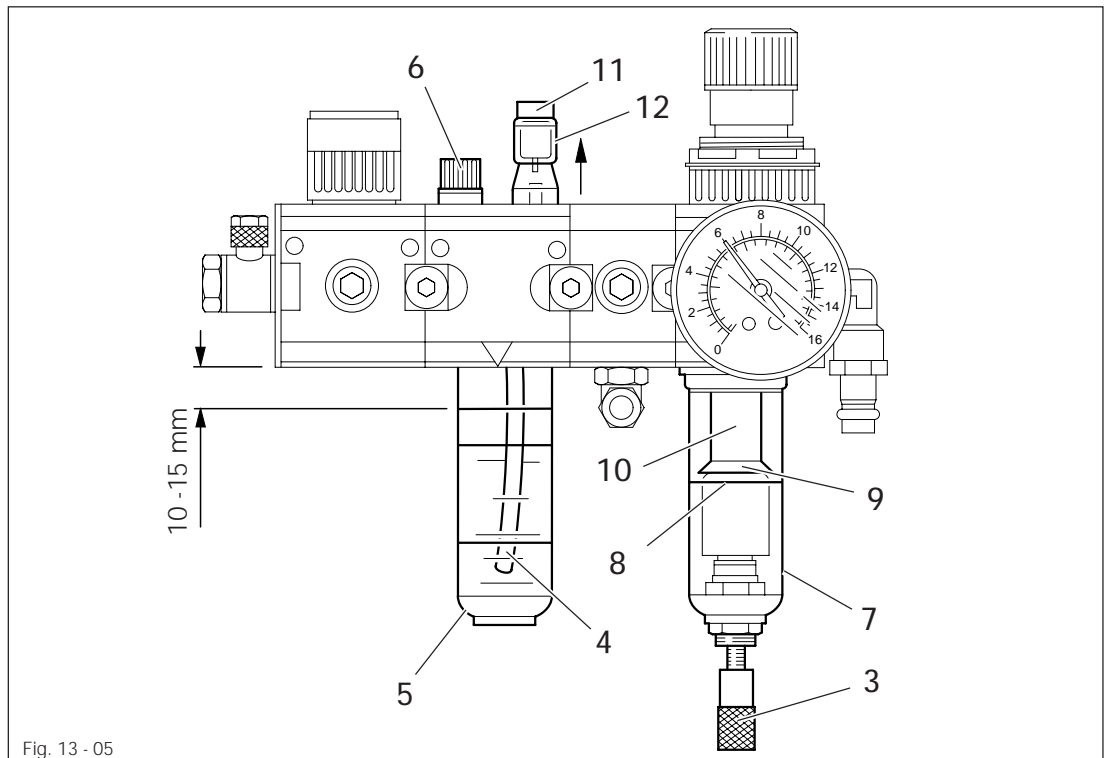

Fig. 13 - 05



- Always check the oil level in the air filter before every use of the machine.



The suction tube 4 must always be under the surface of the oil.

If required:



Turn off compressed air!

- Check container 5 for dirt.
- If required, unscrew container 5 and clean, e.g. with petroleum ether.
- Screw container 5 back on. Observe the joint ring.
- Open screw 6 and fill oil into the container up until 10-15 mm underneath the top of container 5.
- Tighten screw 6 and open compressed air.



Only use oil with a mean viscosity from 22.0 mm²/s to 46.0 mm²/s at 40°C and a density from 0.865 g/cm³ to 0875 g/cm³.

The oils used must not cause the seal materials to swell or shrink more than a nominal amount under different operating conditions.

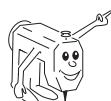

We recommend PFAFF sewing machine oil.
Part no. 280-1-120 144.

13.03.03 Checking the water level and emptying the water trap (Fig. 13-05)

- Check the water level in water container 7 before every use of the machine.



The water level must be under marking 8.

If required:

- Open drain screw 3 and empty water container 7.
- Tighten drain screw 3.

13.03.04 Cleaning the air filter (Fig. 13-05)



The air filter is to be cleaned when the working air pressure of 6 bar is no longer reached.



Turn off the compressed air!



- Unscrew container 7.
- Unscrew disk 9.
- Remove filter 10.
- Clean filter 10 and container 7 with petroleum ether.
- Blast filter 10 from the inside to the outside with compressed air.
- Observe the joint ring when putting back together.
- Open compressed air.

13.03.05 Adjusting the drip feed rate on the oil vaporizer (Fig. 13-05)

- Adjust dosing screw 11 so that adequate lubrication of the cylinders and valves is guaranteed (1 drop per 100 work cycles).

13.03.06 Cleaning the vaporizer jet (Fig. 13-05)



Turn off the compressed air.



- Unscrew dosing screw 11 as far as possible.
- Unscrew vaporizer jet 12 and blast with compressed air in the direction of the arrow.
- Observe the joint ring when putting back together.
- Open compressed air and readjust drip feed speed.

13.04 Lubricating the cylinder for the runner

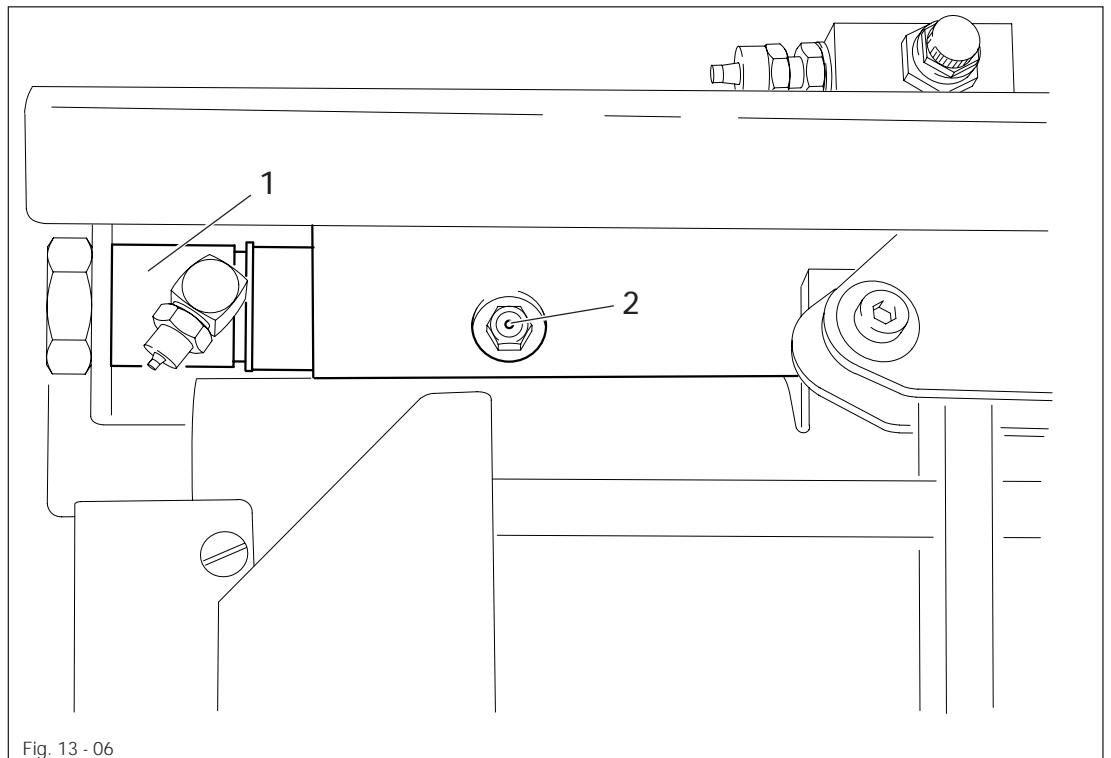

Fig. 13 - 06



Turn the machine off by pulling the mains plug out of the electrical socket!



- Grease cylinder 1 for the runner every 90 workdays.
- Fill grease through hole 2 with a grease gun.



Only use "ESSO BEACON 2" grease!

13.05

Checking and topping up the oil level for the sewing machine

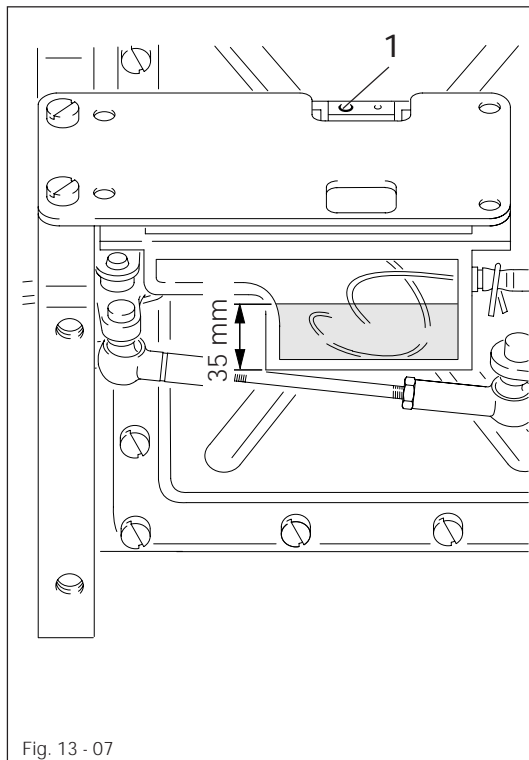

Turn the machine off by pulling the mains plug out of the electrical socket!

- Pull out sewing machine (see **Chapter 14.02 Pulling out the sewing head**).
- Fill oil through hole 1 until the oil container is filled up to a **maximum of 35 mm**.
- Push the sewing machine back in (see **Chapter 14.03 Pushing in the sewing head**).



Only use oil with a mean viscosity of $10.3 \text{ mm}^2/\text{s}$ at 40°C and a density of 0.847 g/cm^3 at 15°C .



We recommend PFAFF sewing machine oil.
Part no. 280-1-120 105.

14 Adjustment



All relevant safety regulations are to be observed! The machine is to be separated from the power supply and secured against being switched on again before all adjustment work.



All adjustments in these adjustment instructions are based on a completely assembled machine. Covers on the machine which have to be removed and replaced for checks and adjustment work are not mentioned. All screws must be retightened after all adjustments.

14.01 Tools, gauges and other accessories

- Screwdrivers with blade width from 2 to 10 mm
- Wrenches (spanners) with jaw width from 7 to 14 mm
- Allan keys from 1.5 to 6 mm
- Fork wrench with 22 mm jaw width
- Metal rule, Part No. 08-880 218-00
- Rig pin (5 mm diameter), Part No. 13-030 341-05
- Adjustment gauge, Part No. 61-111 642-19
- Sewing thread and test material

14.02 Pulling out the sewing head



The sewing head is to be pulled out of the machine for service and maintenance work.

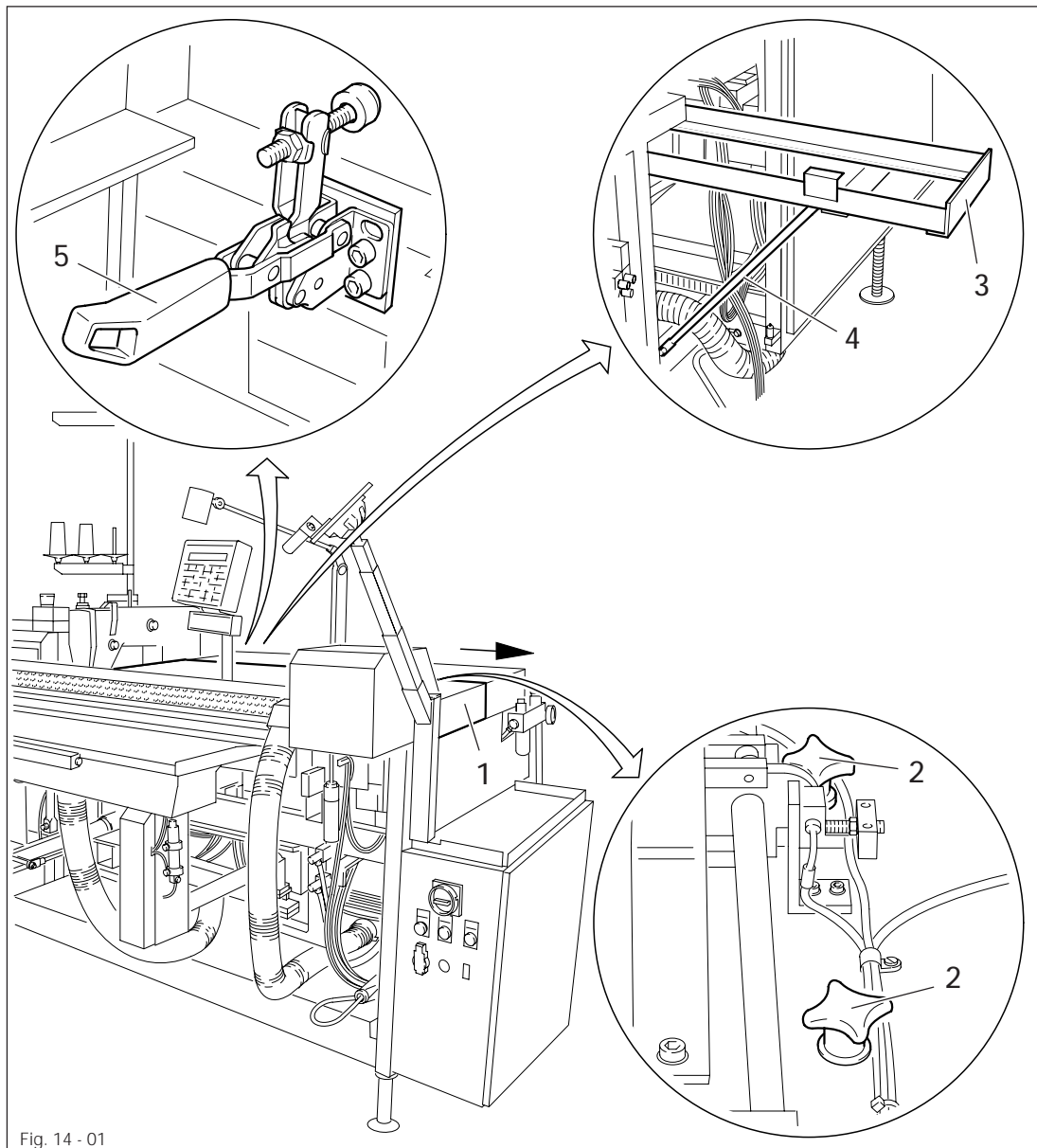

Fig. 14 - 01



Turn the machine off by pulling the mains plug out of the electrical socket!



- Open cover 1 and the tension lever on the pre-loading station.
- Loosen knobs 2 and push the pre-loading station in the direction of the arrow until it is touching.
- Position frame 3 horizontally and hook in support 4.
- Open tension lever 5 and pull the sewing head back until you feel it stop.
- For work underneath the level of the bed plate, lay the sewing head on its back.



Danger of crushing between sewing head and frame!

14.03 Pushing in the sewing head (Fig. 14-01)

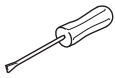

- If necessary, swing sewing head back to its original position.



Danger of crushing between sewing head and frame!

- Push the sewing head in until you feel it stop and close tension lever 5.
- After folding down support 4, fold frame 3 downwards.
- Secure frame 3 and support 4 in their clamps.
- Push the pre-loading station back until you feel it stop.
- Close the tension lever on the pre-loading table.
- Tighten knobs 2.
- Close cover 1 if necessary.

14.04 Lengthwise pre-adjustment of the sewing head

Requirement

The distance between the front edge of carrier 3 and the center of the needle must be 91 mm.

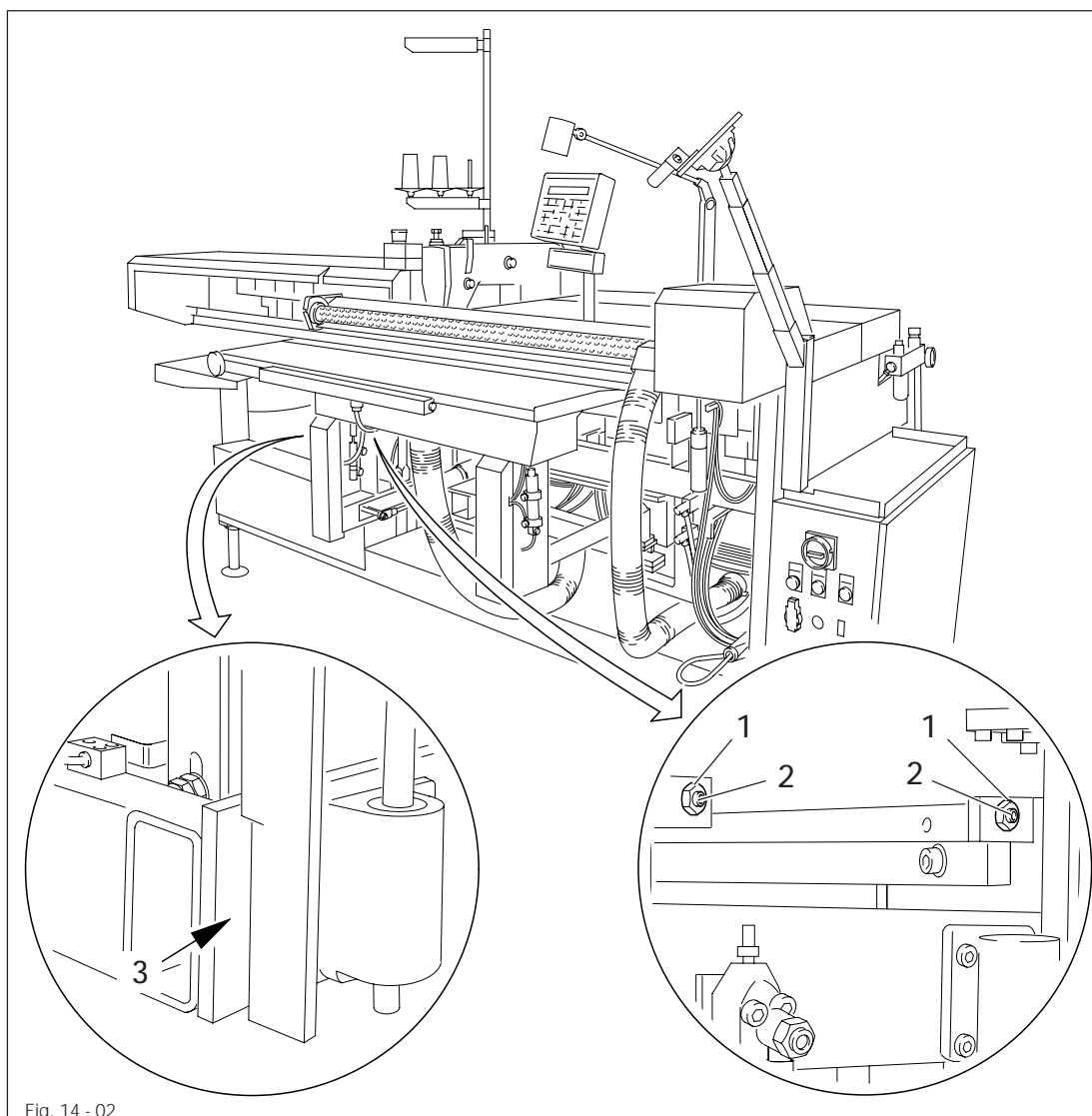
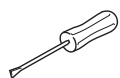

Fig. 14 - 02



- Dismount wiper flap.
- Check measurement.
- If necessary, loosen nut 1 and turn threaded pins 2 in accordance with the requirement.
- Tighten nuts 1.
- Mount wiper flap.

14.05 Loading table

14.05.01 Basic height setting of the loading table

Requirement

1. Loading table 1 must be central between guide rails 2 and 3.
2. Loading table 1 must be parallel to guide rails 2 and 3.

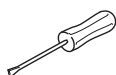
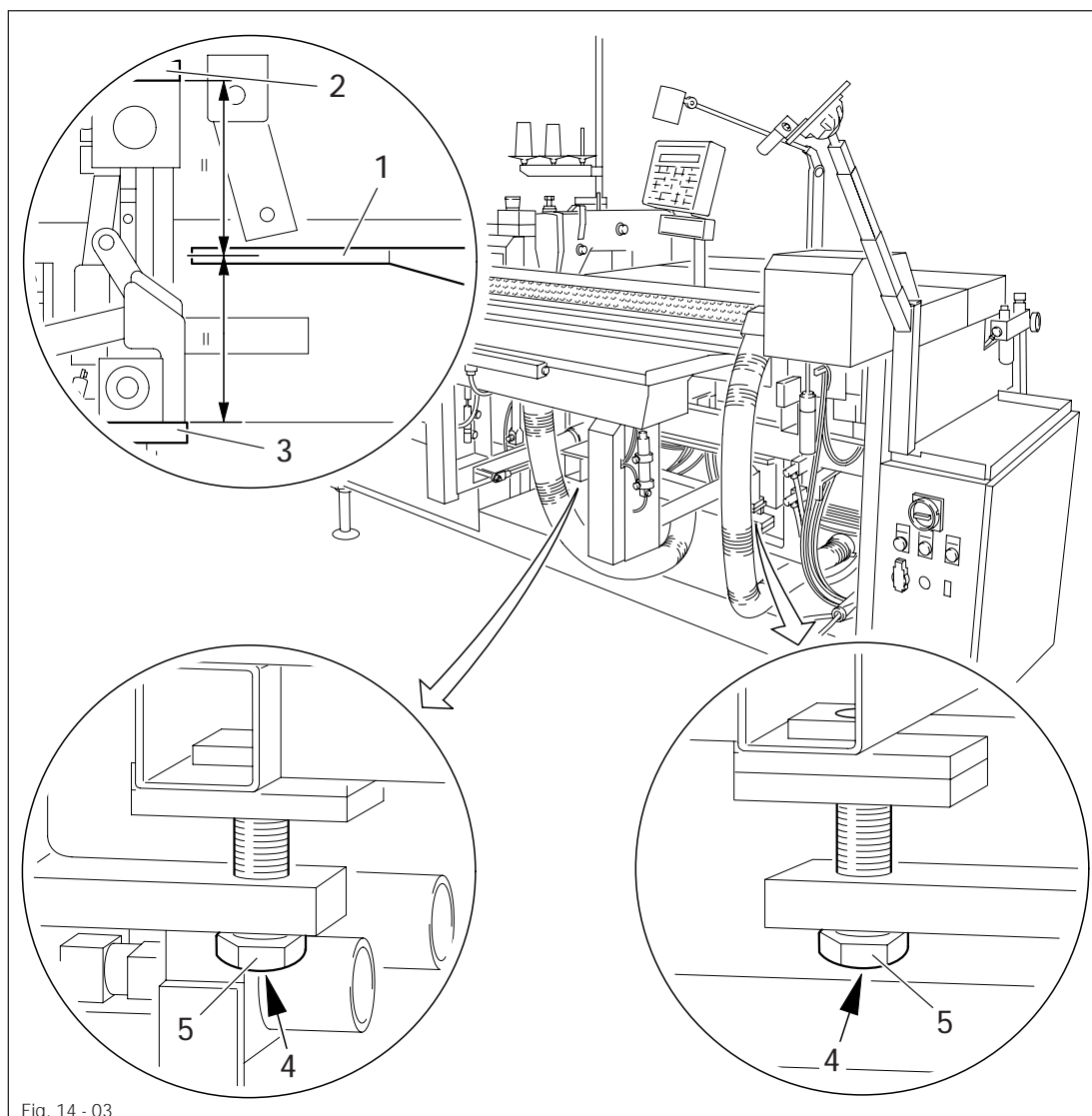

- Loosen screws 4 and turn screws 5 in accordance with requirements 1 and 2.
- Tighten screws 4.

Adjustment

14.05.02 Parallelism of the loading table

Requirement

Loading table 1 must be parallel to runner 2.

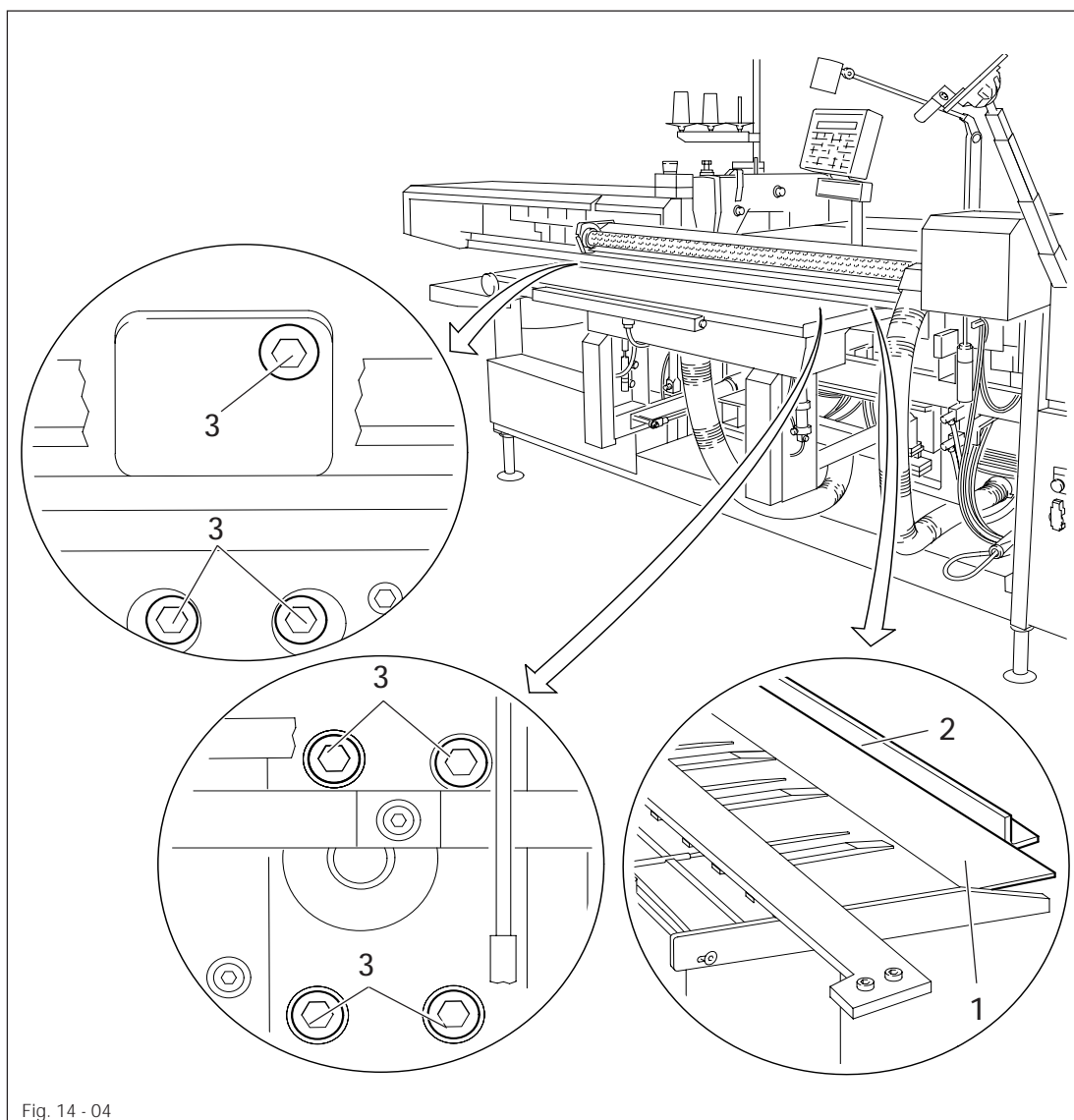
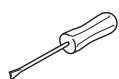

Fig. 14 - 04



- Dismount the cover plate of the loading table.
- Retract the loading table manually.
- Loosen screws 3 and move the loading table in accordance with the requirement.
- Tighten screws 3.
- Remount the cover plate.

14.05.03 Retraction depth of the loading table

Requirement

1. With the loading table retracted, there must be a distance of **12 mm** between the front edge of the table and the center of the needle hole.
2. With the loading table extended, screws **4** must touch the stops.

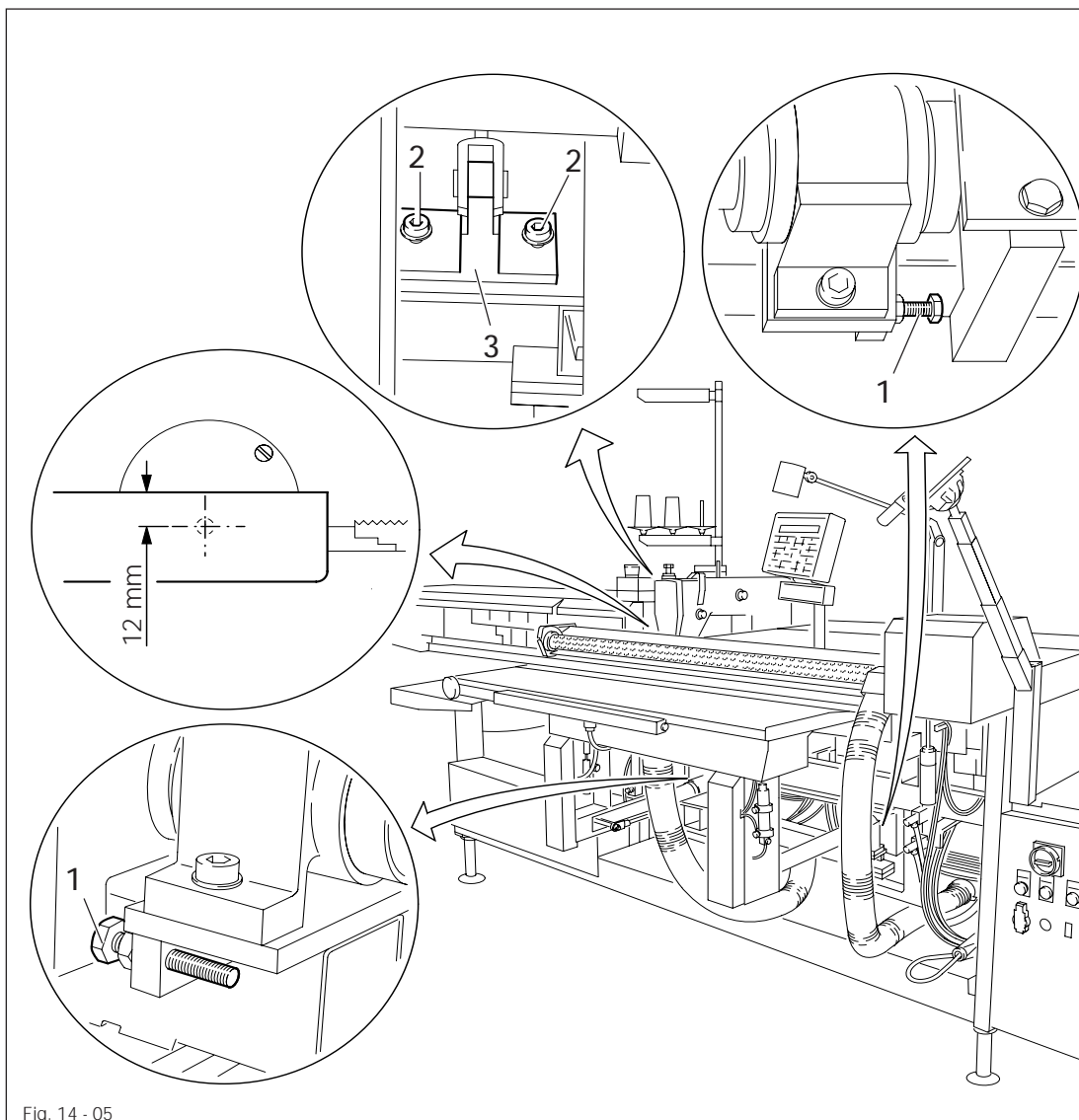
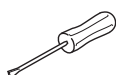

Fig. 14 - 05



- Screw in stop screws **1** until they no longer touch the stops.
- Loosen screws **2** on cylinder carrier **3** and move the cylinder in accordance with the requirement.
- Tighten screws **2**.
- Sew a test seam with a medium material and a correction value of 1.5.
- If required, carry out a correction (cylinder carrier **3**).
- If the seam construction is correct, screw stop screws **1** until they touch the stops.

Adjustment

14.06 Sewing head

14.06.01 Height of the sewing head

Requirement

There must be a distance of 2.5 mm between the top edge of the needle plate and the bottom edge of the table extension.

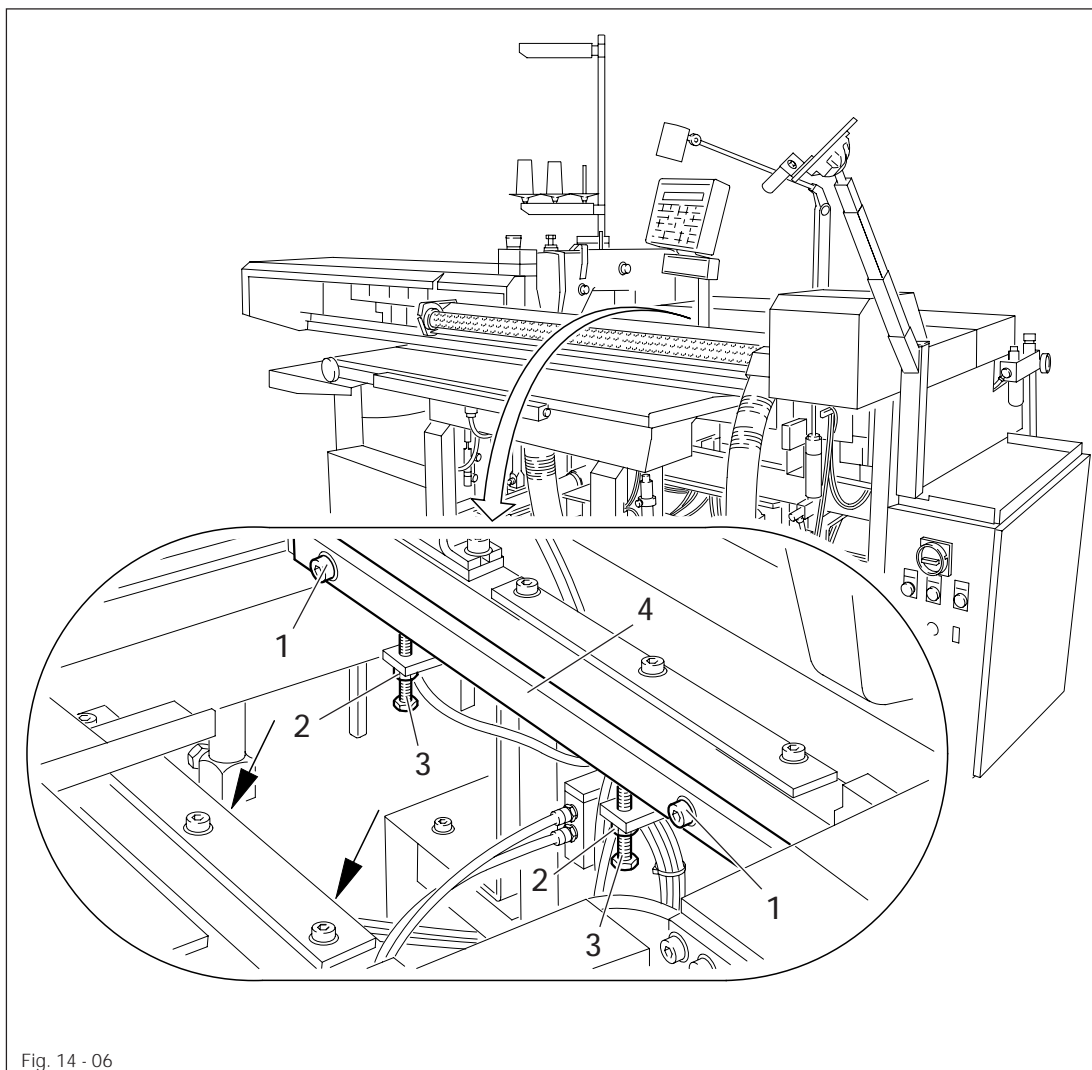
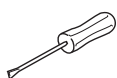

Fig. 14 - 06



Dismount the presser foot and remove the needle!



- Pull out the sewing head (see Chapter 14.02 Pulling out the sewing head).
- Loosen screws 1.
- Loosen nuts 2 and turn screws 3 in accordance with the requirement.
- Take care that guides 4 are horizontal.
- Tighten nuts 2.
- Tighten screws 1.
- Push in the sewing head (see Chapter 14.03 Pushing in the sewing head)

14.06.02 Lateral alignment of the sewing head

Requirement

1. There must be a distance of **50 mm** between the front edge of loop spreader **1** and the center of the needle hole.
2. The sewing head must be at a right angle to the loading table.

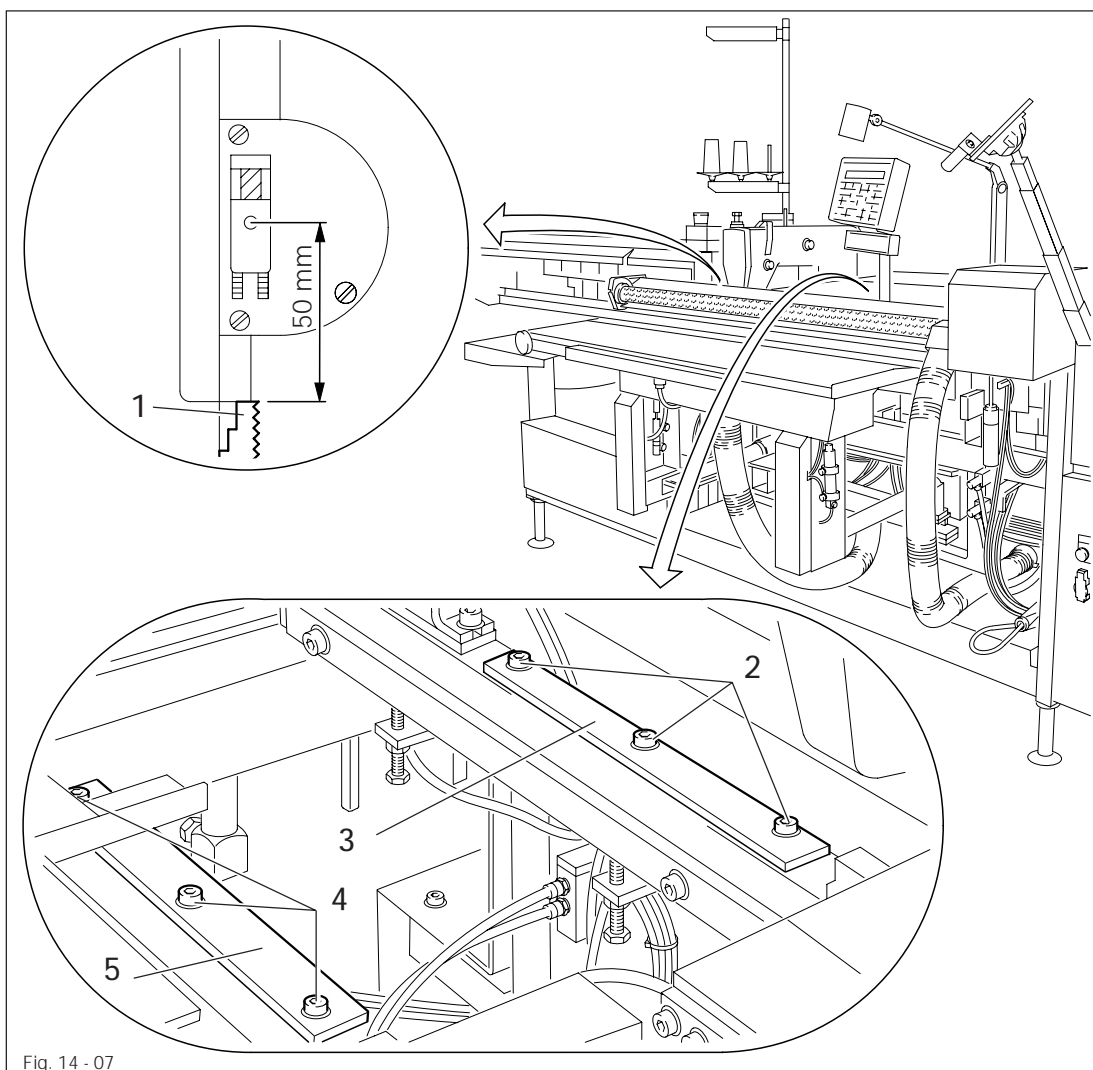
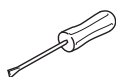

Fig. 14 - 07



- Loosen screws **2** and **4**.
- Move runner **3** in accordance with requirements **1** and **2**.
- Tighten screws **2**.
- Place runner **5** parallel and free of play against the sewing machine head and tighten screws **4**.

Requirement

1. Work surfaces 1 and 2 must be laterally flush with the needle plate.
2. Work surfaces 1 and 2 must be horizontal and at the same height as the needle plate.

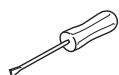
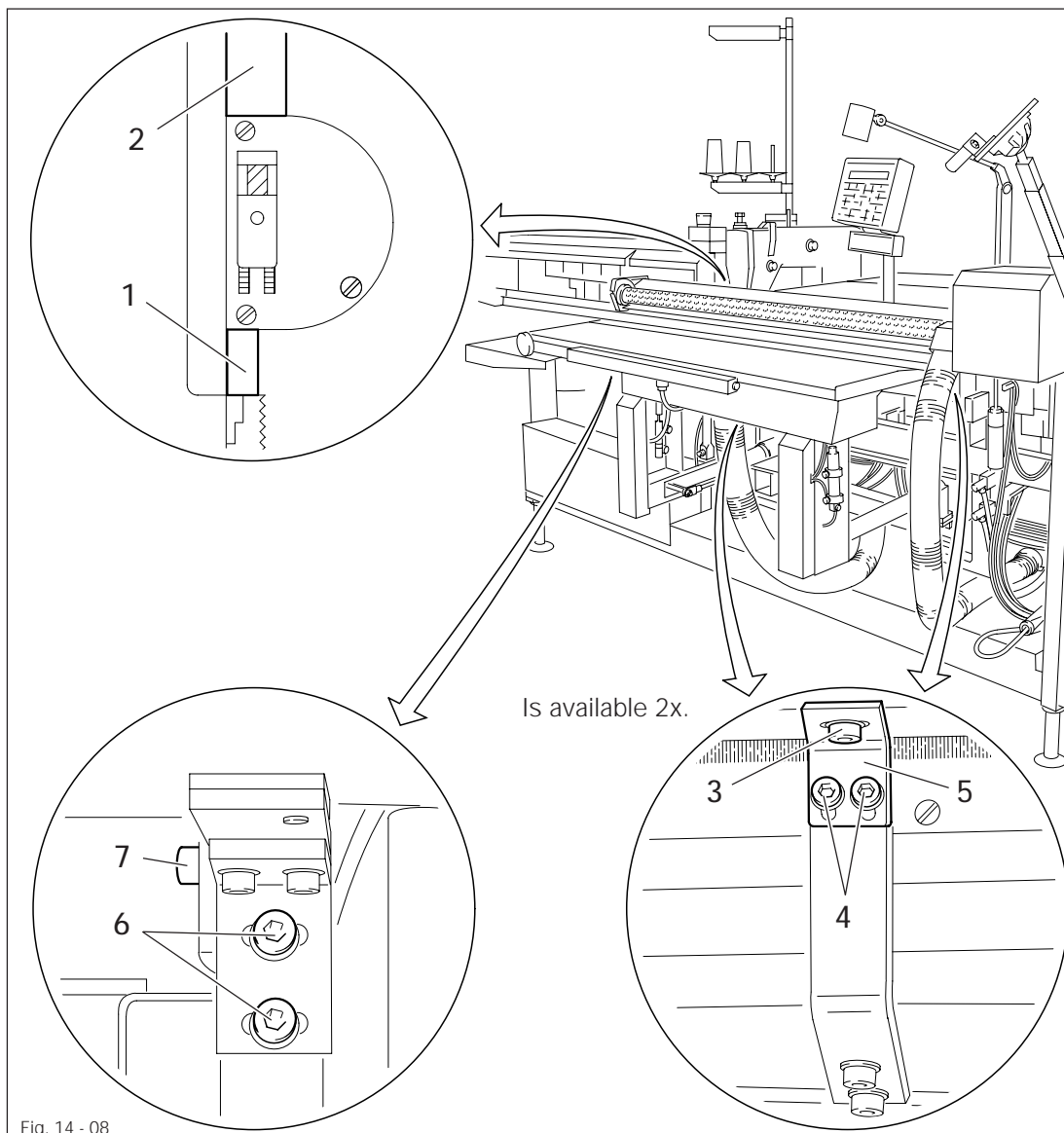

- Loosen screws 3, 4, 6 and 7 and adjust work surfaces 1 and 2 in accordance with requirements 1 and 2.
- Tighten screws 3, 4, 6 and 7.

14.08 Positioning pipe

14.08.01 Pre-adjusting the positioning pipe

Requirement

With the positioning pipe raised, carrier 1 must be parallel to carrier 2.

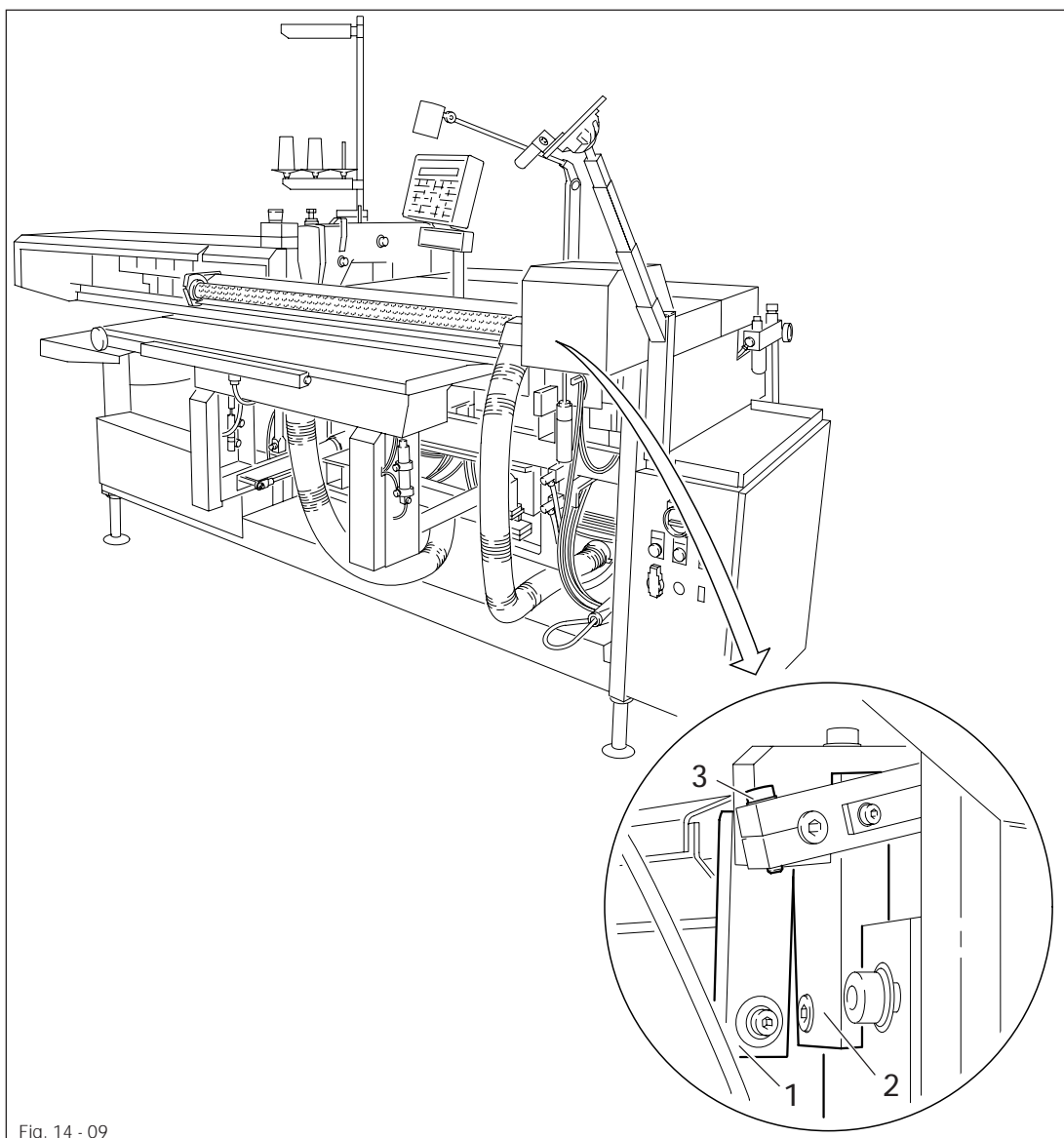
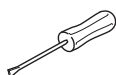

Fig. 14 - 09



- Loosen screw 3.
- Position carrier 1 parallel to carrier 2 in accordance with the requirement.
- Tighten screw 3.

14.08.02 Parallelism of the positioning pipe

Requirement

The positioning pipe must touch the loading table along its entire length.

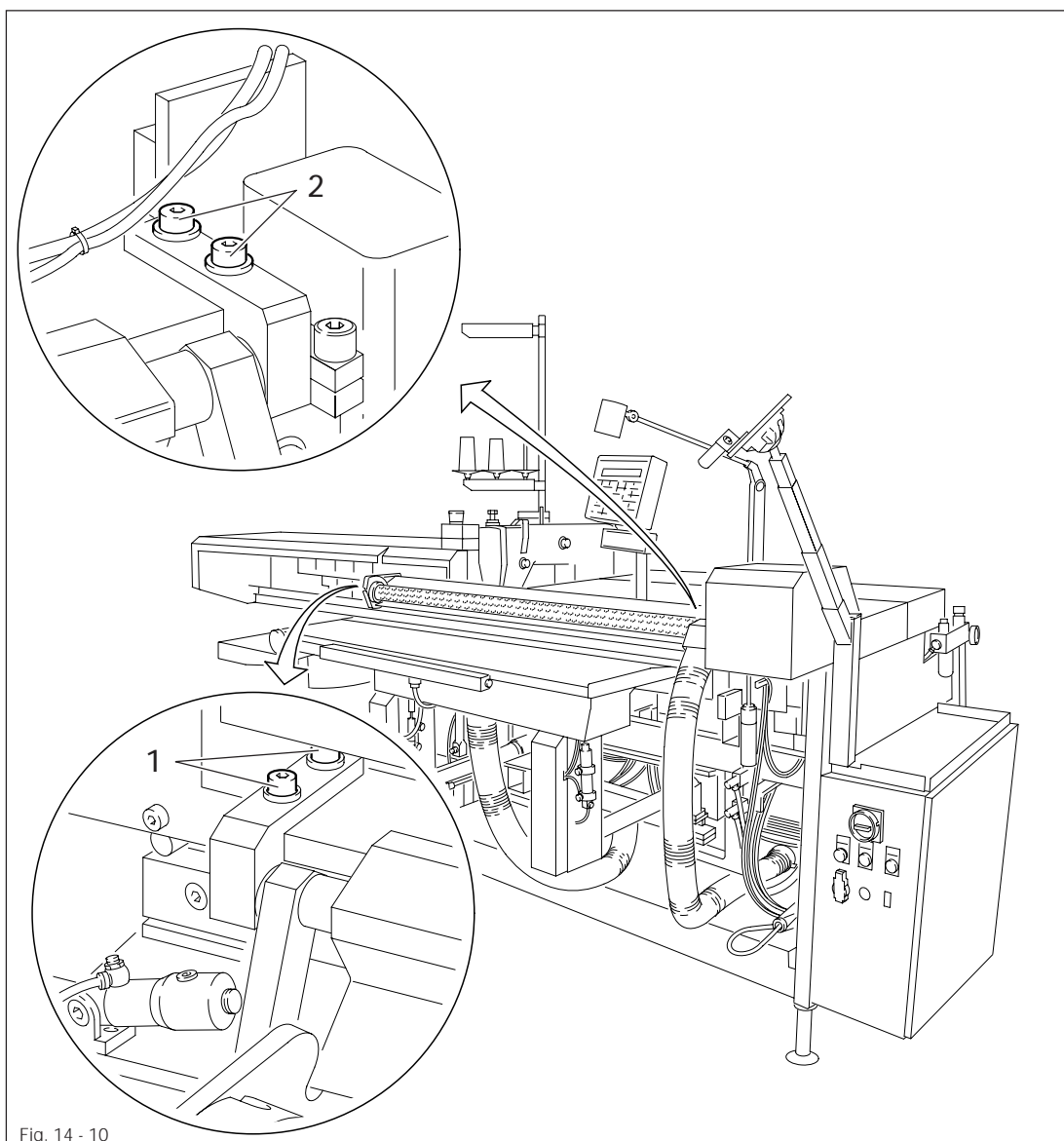
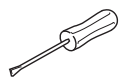

Fig. 14 - 10



- Swing the positioning pipe to its front final position.
- Loosen screws 1 and 2.
- Adjust the positioning pipe in accordance with the requirement.
- Tighten screws 1 and 2.

14.08.03 Height of the positioning pipe

Requirement

1. In its front final position, there must be a distance of 18.9 mm between the top edge of the positioning pipe and the top of the loading table.
2. In its front final position, the holes at the marking must be central to the needles of the loading table.

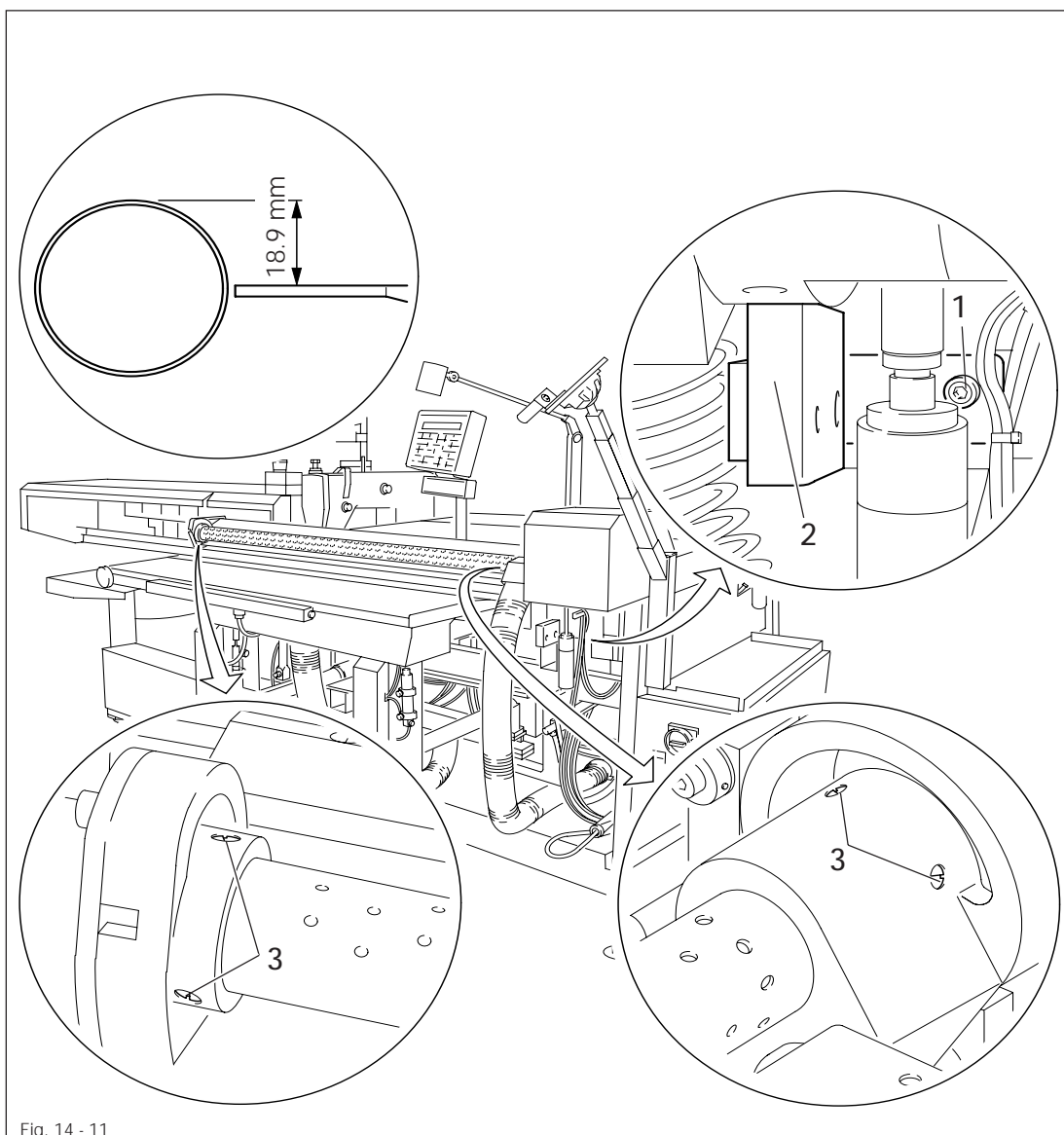
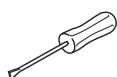

Fig. 14 - 11



- Swing the positioning pipe to its front final position.
- Loosen screw 1 and move plastic stop 2 in accordance with requirement 1.
- Tighten screw 1.
- Loosen screws 3.
- Turn and move positioning pipe in accordance with requirement 2.
- Tighten screws 3.

Requirement

With the needles extended there must be a distance of **4 mm** between the needle points and the front edge of the loading table.

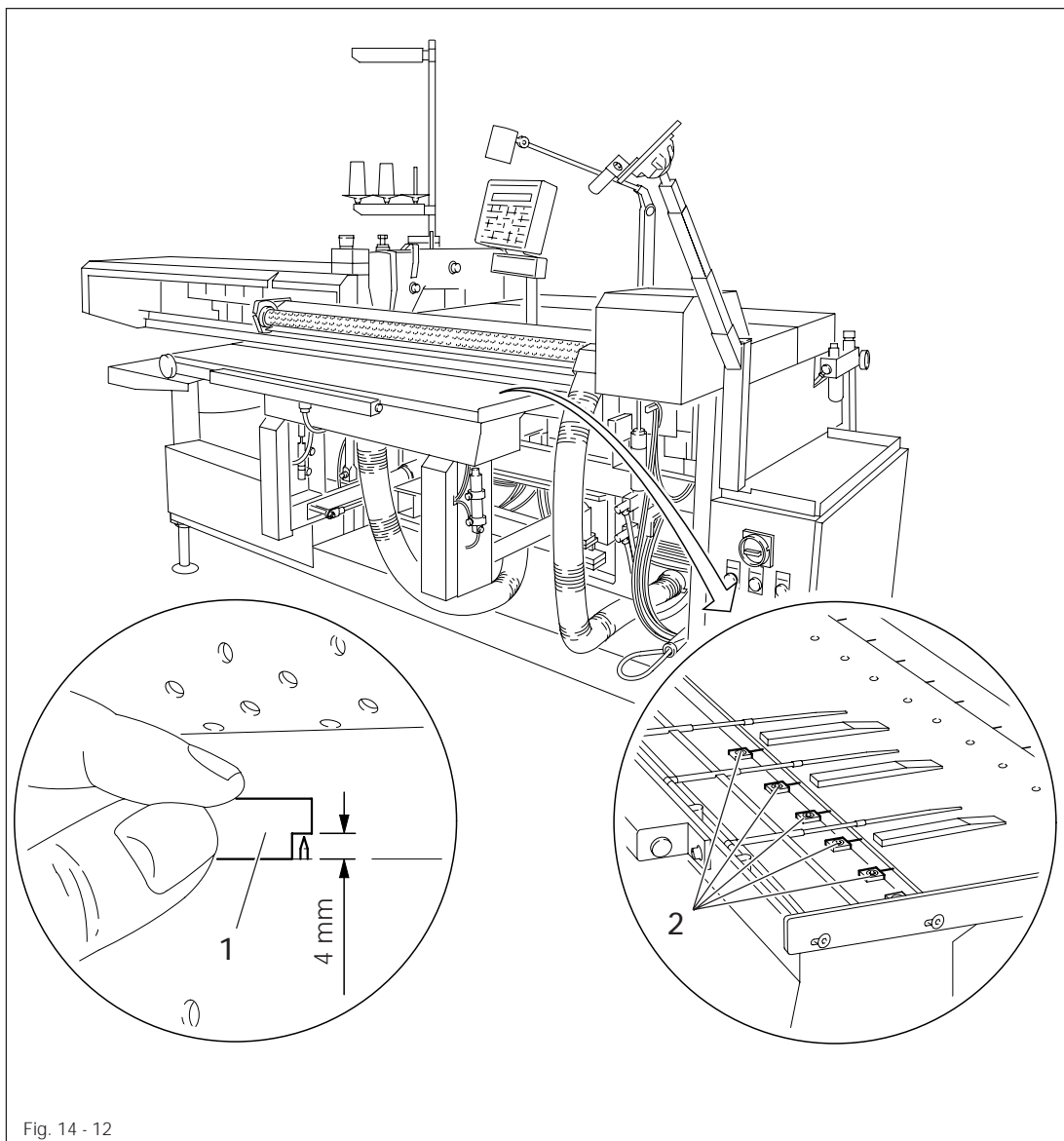
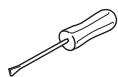

Fig. 14 - 12



- Remove the cover plate of the loading table.
- Extend the needles.
- Check the 4 mm measurement with gauge 1.
- If necessary, loosen screws 2 and move the needles in accordance with the requirement.
- Tighten screws 2.
- The cover plate remains dismantled for further adjustments.

14.10 Loop spreader

Requirement

1. When retracted, loop spreader 1 must be flush with the front edge of the loading table.
2. When being extended, loop spreader 1 must move 3.5 to 4 mm.

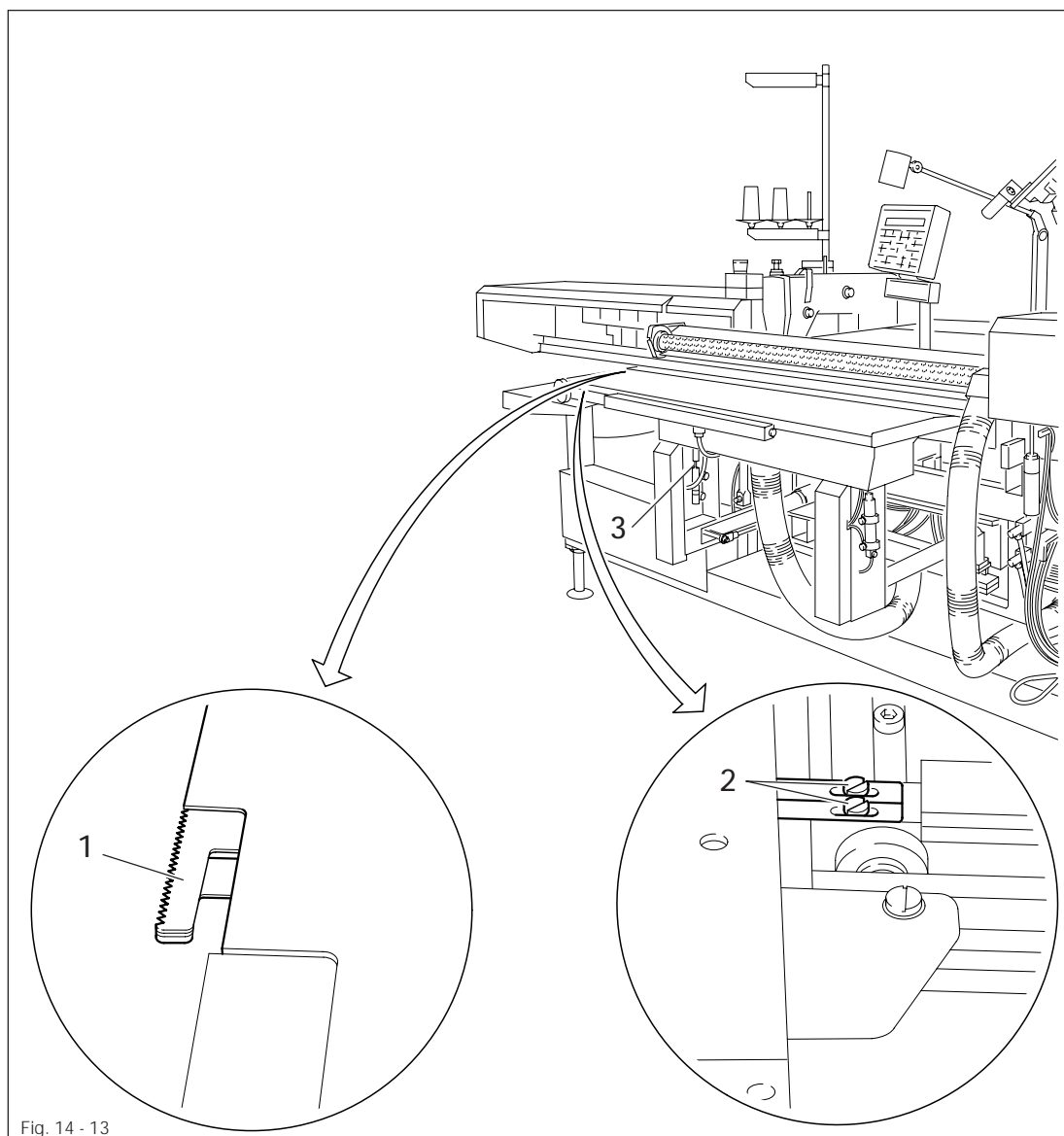

Fig. 14 - 13



- Loosen screws 2 and move loop spreader 1 in accordance with requirement 1.
- Tighten screws 2.
- Move the fork head on cylinder 3 in accordance with requirement 2.

14.11 Table extension

Requirement

1. When extended, the front edge of table extension 1 must be flush with the front edge of the loading table.
2. When retracted, the distance between the front edge of table extension 1 and the front edge of the loading table must coincide with the pre-selected setting on dial 3.

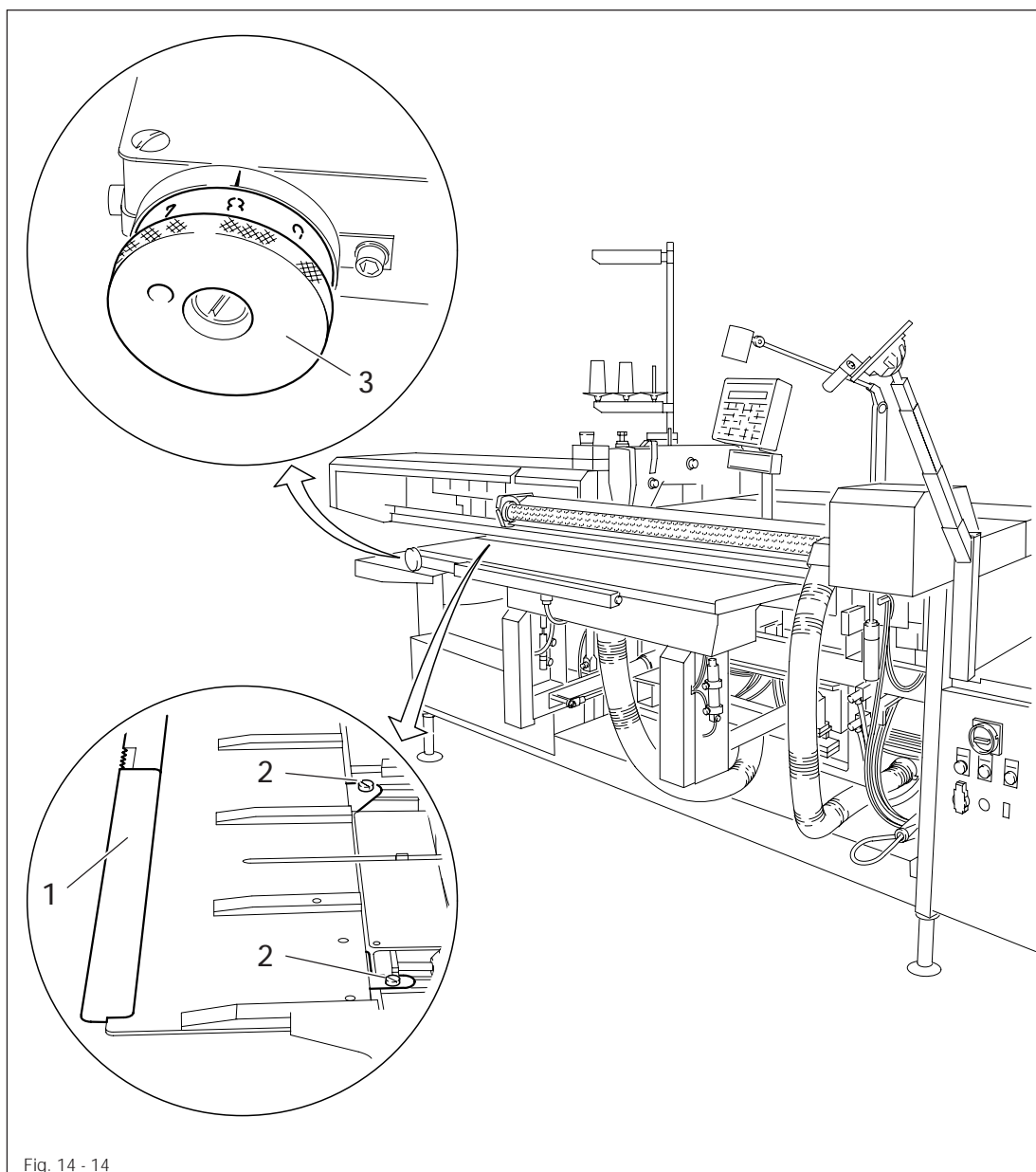
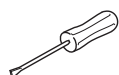

Fig. 14 - 14



- Loosen screws 2 and move table extension 1 in accordance with the requirement.
- Tighten screws 2.
- Turn the stop pin of dial 3 in accordance with requirement 2.

14.12 Pre-loading station

14.12.01 Height of the pre-loading station

Requirement

1. The claws of the pre-loading station must touch the retracted loading table from the top and the bottom at the same time.
2. The claws must be parallel to the loading table.

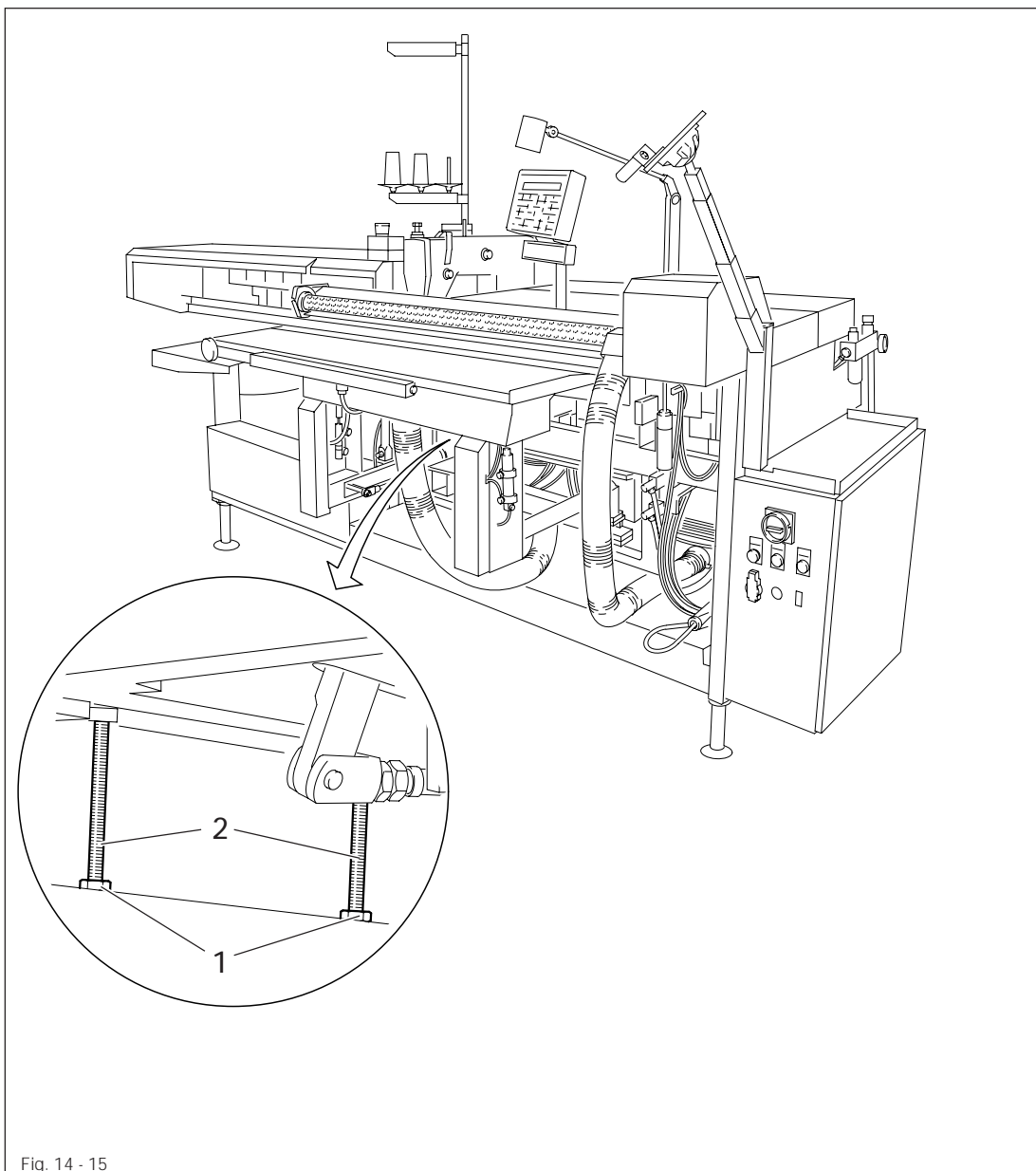
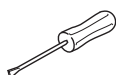

Fig. 14 - 15



- Retract the loading table.
- Loosen nuts 1 (see Fig. 14-15) and screws 4 (see Fig. 14-16).
- Turn shouldered pins 2 in accordance with requirements 1 and 2.
- Tighten nuts 1 and screws 4.

14.12.02 Position of the pre-loading station

Requirement

1. The inner claws of the pre-loading station must touch the retracted loading table approx. **6 to 7 mm** behind the front edge.
2. The distance between the front claw edge of the pre-loading station and the center of the needle hole must be **50 mm**.

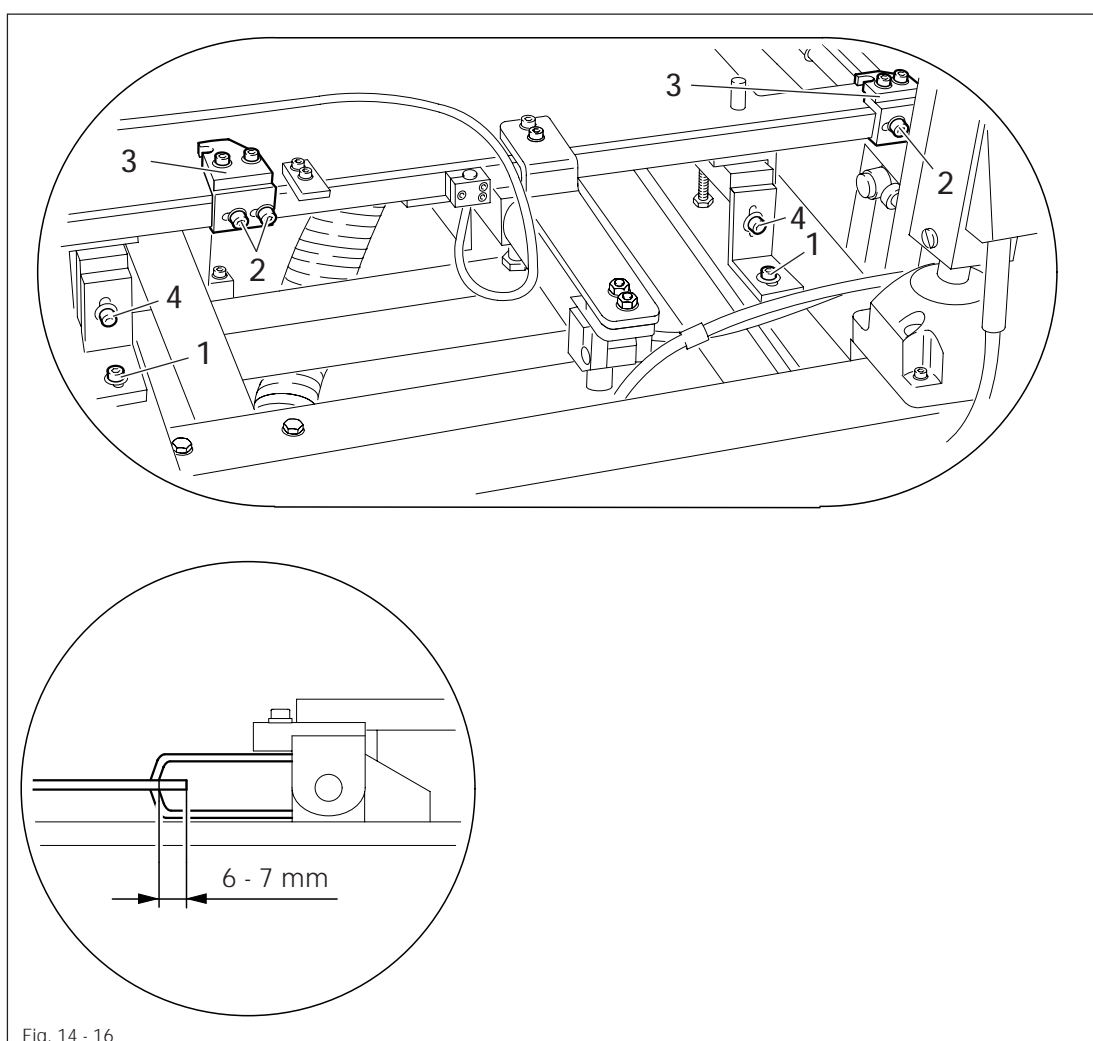
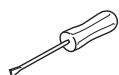

Fig. 14 - 16



- Retract loading table.
- Loosen screws 1 and move the pre-loading station in accordance with requirement 1.
- Tighten screws 1.
- Loosen screws 2 and move mounting 3 in accordance with requirement 2.
- Tighten screws 2.

14.13 Brushes

14.13.01 Long brush row

Requirement

1. When closed, the brushes must be parallel to each other and touching. The loading table must retract exactly through the middle of the brushes.
2. The brushes must close far enough so that the material is smoothed out perfectly and when open they should be approx. 10 mm apart.

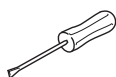
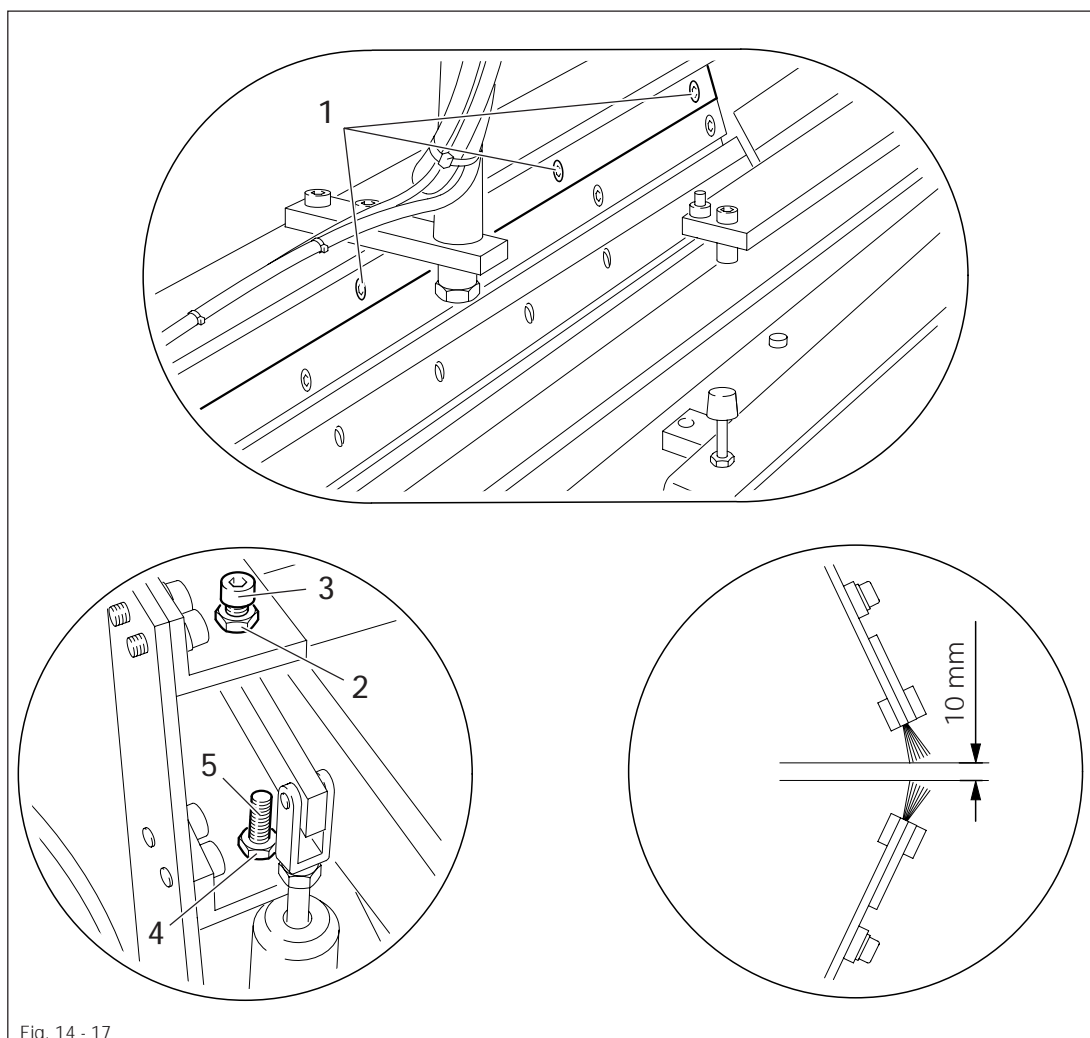

- Adjust screws 1, 3 and 5 in accordance with requirements 1 and 2.



The closing of the brushes is dependent on the material to be sewn and must be corrected in accordance with the sewing result.

Requirement

1. When closed, the upper brush must just touch the loading table.
2. When open, the upper brush must be approx. 4 mm above the loading table.
3. When open, the lower brush must be approx. 4 mm underneath the loading table.
4. When closed, the lower brush must touch the loading table.

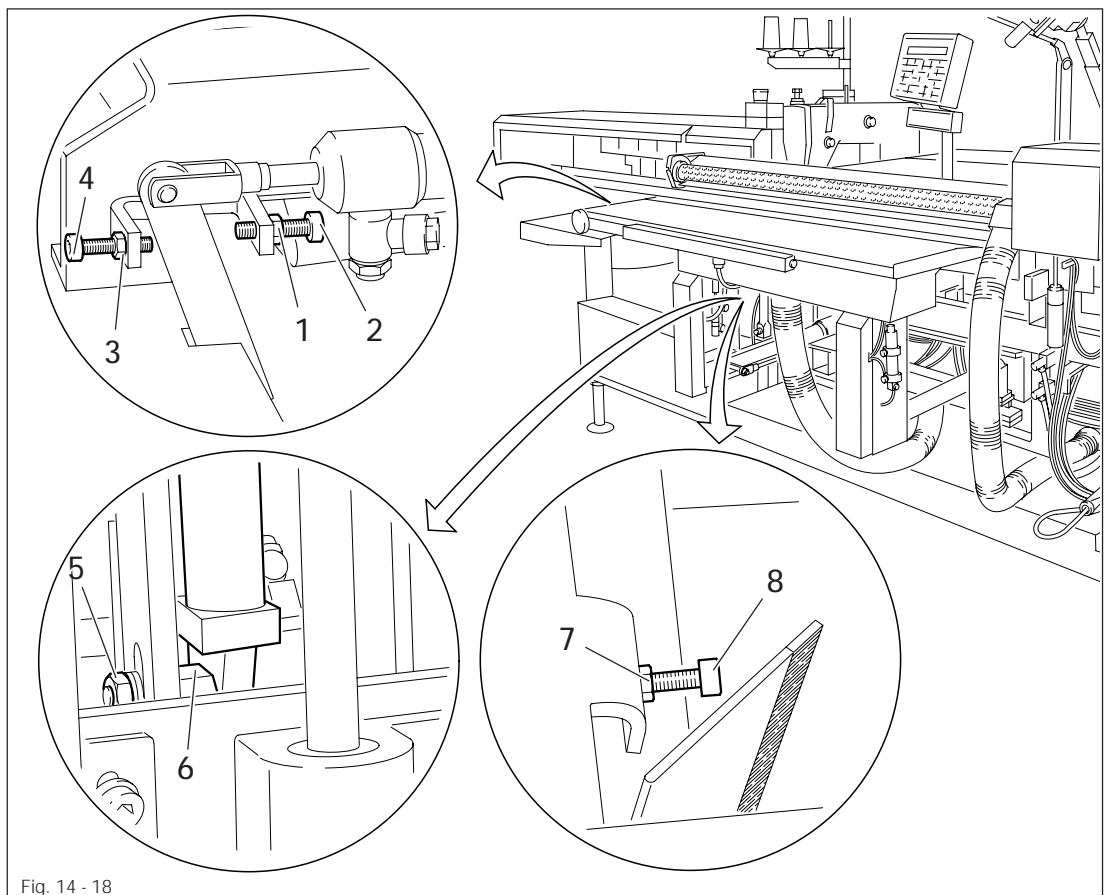
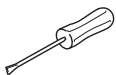

Fig. 14 - 18



- Loosen nut 1 and turn front stop screw 2 in accordance with requirement 1.
- Tighten nut 1.
- Loosen nut 3 and turn rear stop screw 4 in accordance with requirement 2.
- Tighten nut 3.
- Loosen nut 7 and move stop screw 8 in accordance with requirement 3.
- Tighten nut 7.
- Loosen nut 5 and move cylinder holder 6 in accordance with requirement 4.
- Tighten nut 5.



The closing of the brushes is dependent on the material to be sewn and must be altered in accordance with the sewing result.

14.14 Catcher-knife unit

14.14.01 Pre-adjusting the catcher-knife unit

Requirement

1. The rear edge of the catcher must be tilted forwards approx. 2° when the catcher is swung in. (The middle of screw 1 is almost flush with the outer edge of screw 2)
2. With the correction value set at 1.5, the catcher must touch the crease line of the material (on medium materials).
3. With the catcher swung in, the highest points of the knife must touch the material.

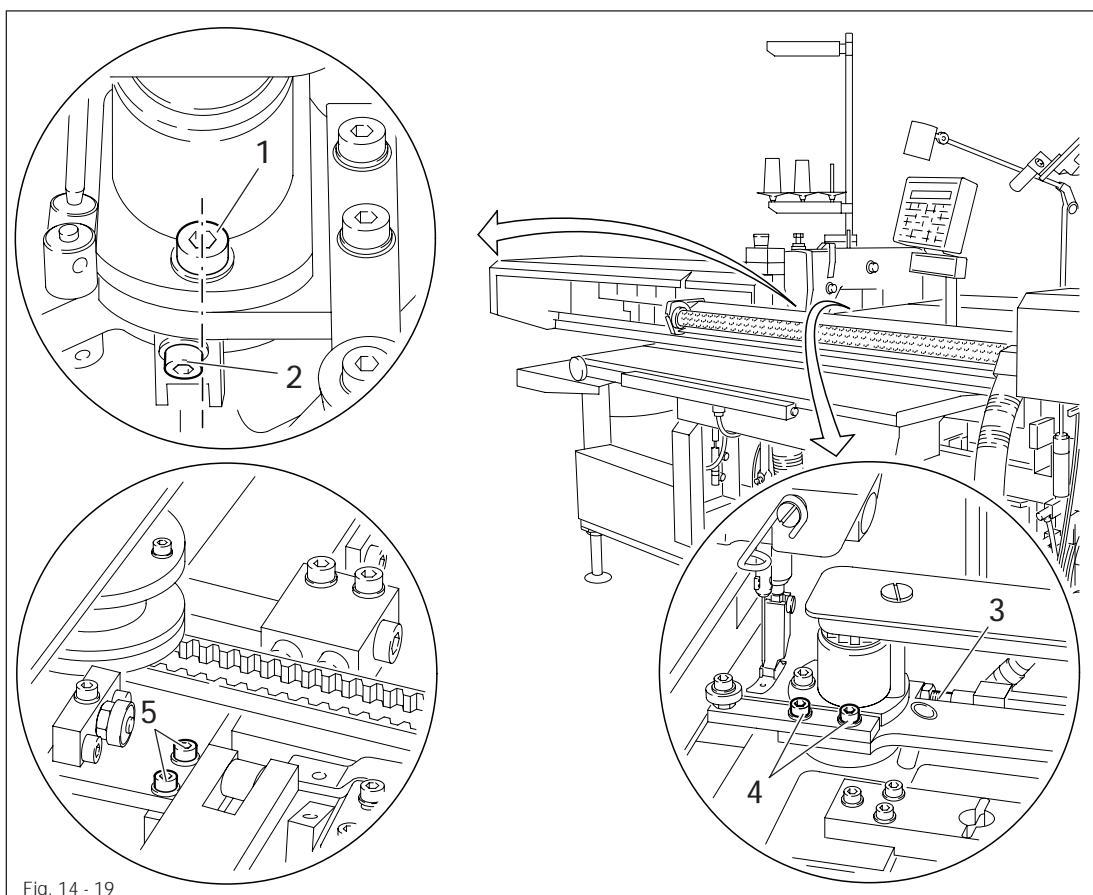
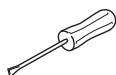

Fig. 14 - 19



- Remove the upper left fabric claw.
- Move plunger 3 of the cylinder in accordance with requirement 1.
- Loosen screws 4 and move the stop in accordance with requirement 2.
- Tighten screws 4.
- Loosen screws 5 and move the knife unit in accordance with requirement 3.
- Tighten screws 5.

14.14.02 Recuperator spring of the catcher

Requirement

Recuperator spring 1 must have as little initial tension as possible. The catcher must, however, swing back reliably.

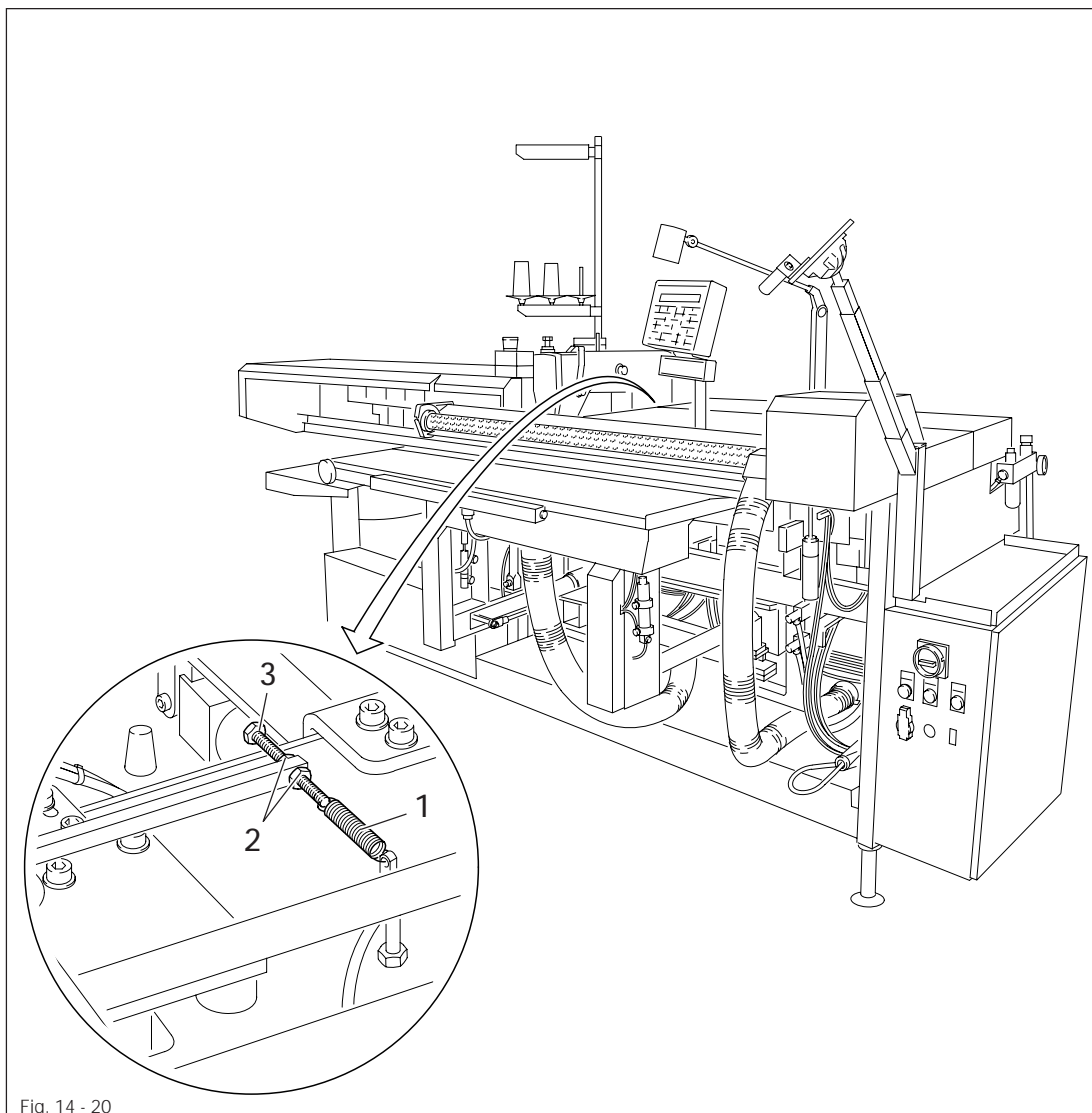
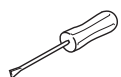

Fig. 14 - 20



- Loosen nut 2 and turn screw 3 in accordance with the requirement.
- Tighten nuts 2.

14.14.03 Height of the knife unit

Requirement

The knife unit must be at the correct height so that the catcher passes through the middle of the loop spreader.

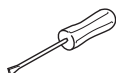
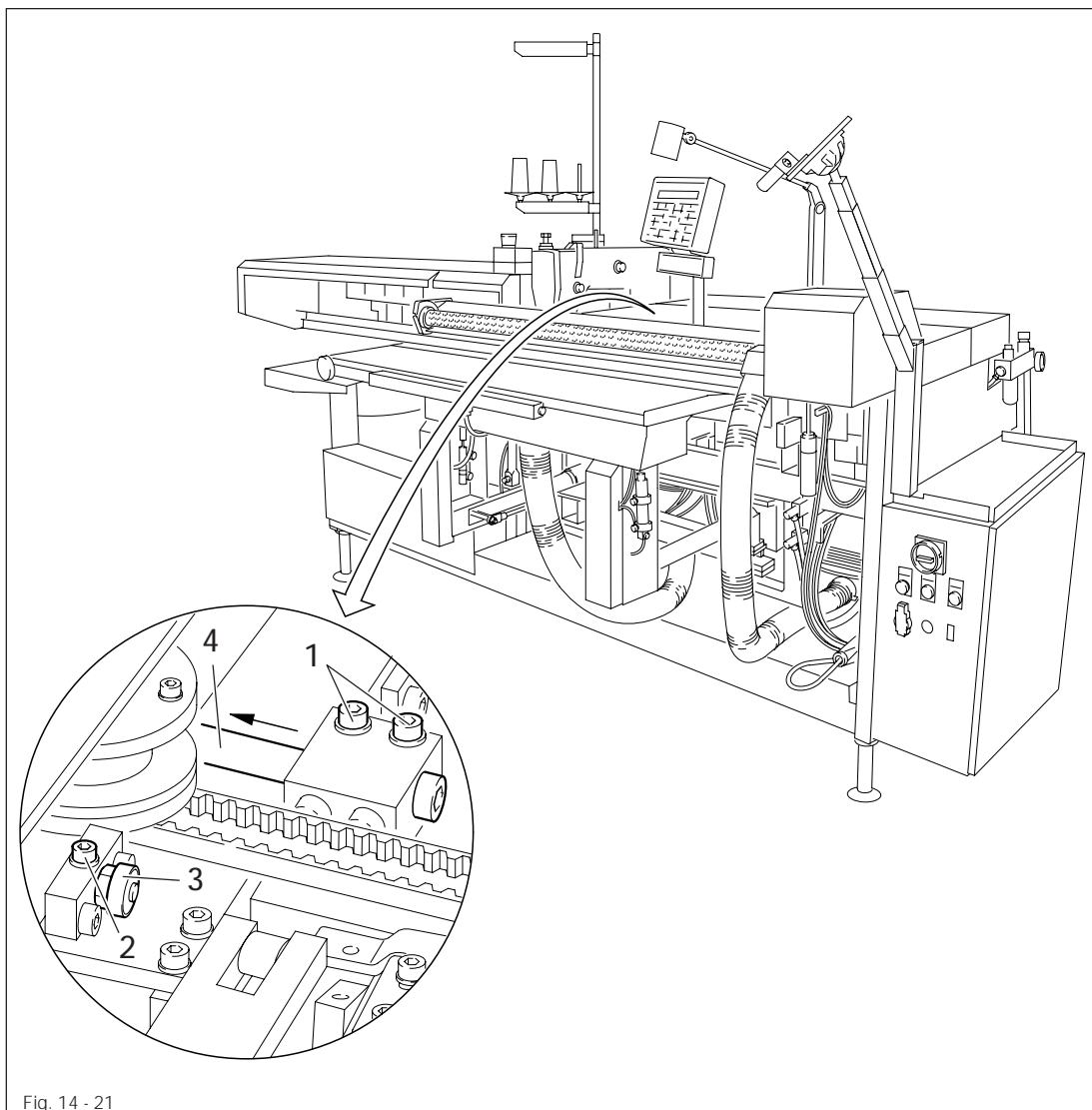

- Loosen screws 1.
- Loosen screw 2.
- Turn eccentric caster 3 in accordance with the **requirement**.
- Tighten screw 2.
- Press against bar 4 in the direction of the arrow and tighten screws 1.

14.14.04 Changing the knife

Requirement

Change the knife when its cutting performance begins to worsen.

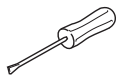
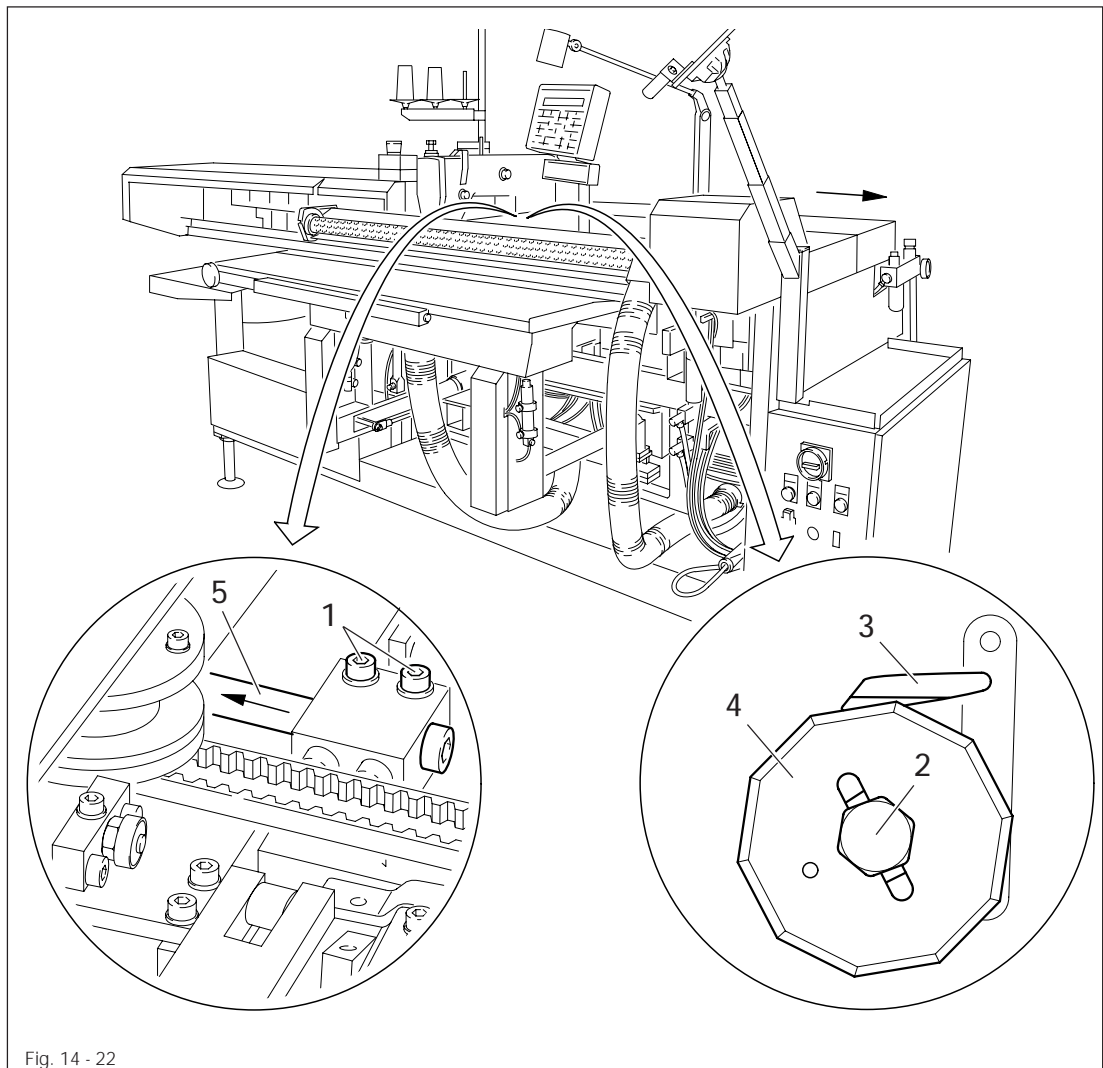

- Open the tension lever on the pre-loading station.
- Loosen the knobs and move the pre-loading station in the direction of the arrow.
- Loosen screws 1.
- Swing up the knife unit.
- Loosen screw 2.
- Replace knife 4 with a new one. Take care to ensure that knife 4 does not touch catcher 3 at the point of its largest diameter.
- If necessary, remove catcher 3 and place a washer under it.
- Tighten screw 2.
- Press bar 5 in the direction of the arrow and tighten screws 1.
- Push the pre-loading station back until it touches, close the tension lever and tighten the knobs.

14.15 Workholder bar

14.15.01 Zero point of the workholder bar in Y-direction

Requirement

With the material thickness correction value at 3.0, there must be a distance of approx. 0.3 mm between the workholder bar and the presser foot.

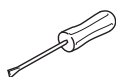
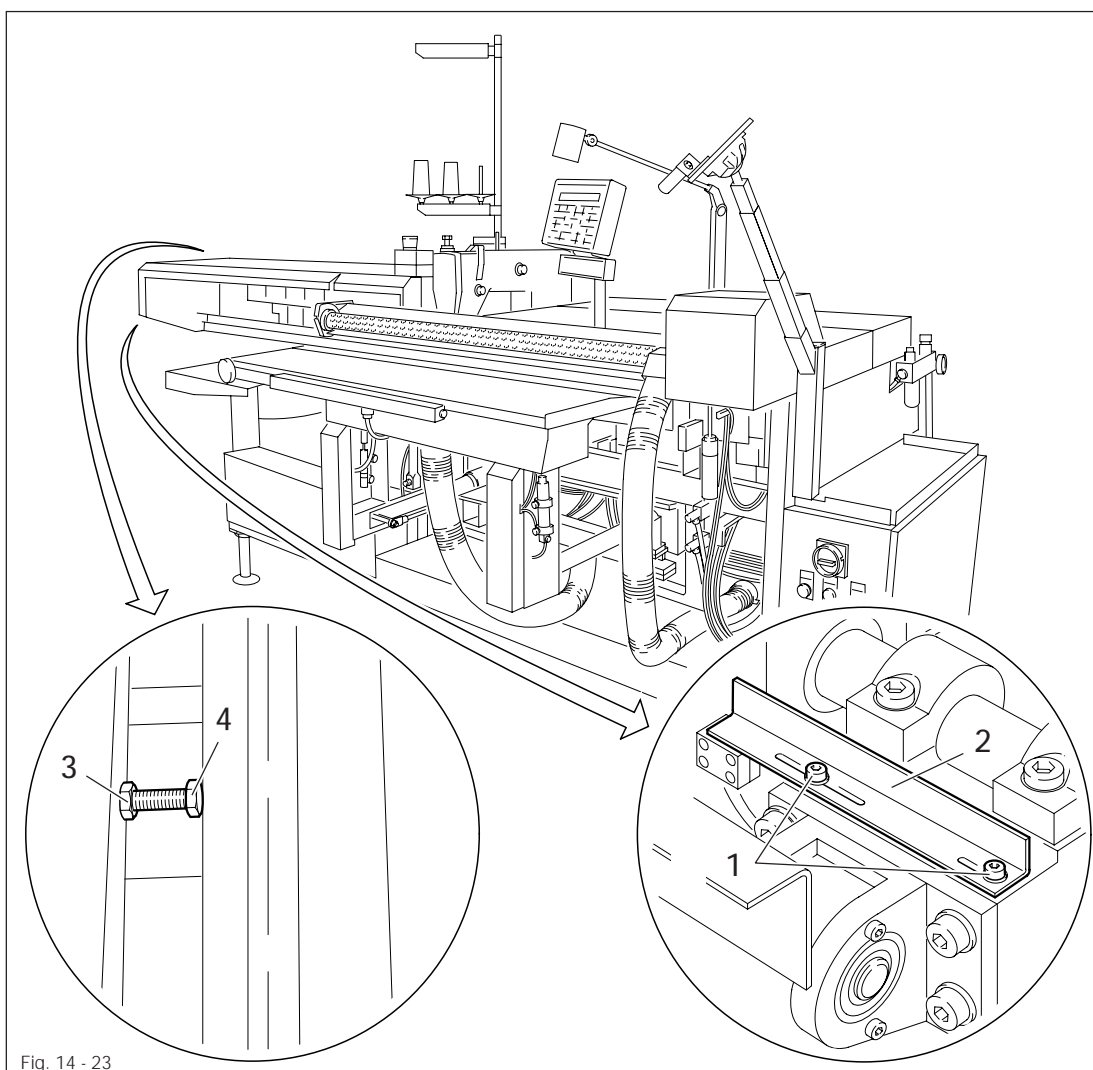

- Loosen screws 1 and move bracket 2 in accordance with the requirement.
- Tighten screws 1.
- In this position, loosen nut 3 and turn screw 4 against the stop.
- Tighten nut 3.

Adjustment

14.15.02 Pneumatic workholder-bar pressure

Requirement

1. The admission pressure must be set at approx. 1 to 1.5 bar.
2. The main pressure must be set at approx. 5 to 6 bar.

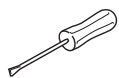
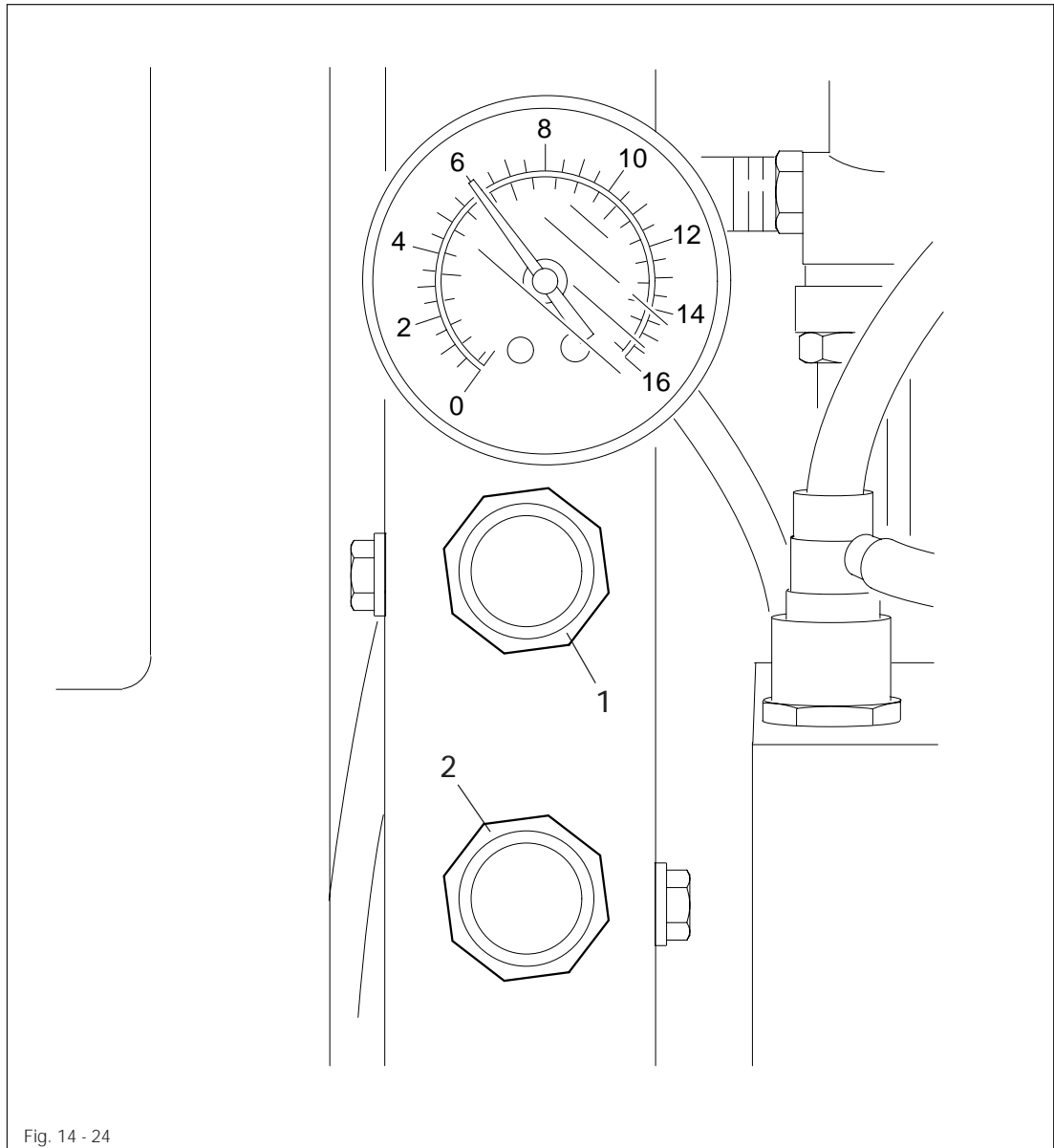

- Turn gauge 1 in accordance with requirement 1.
- Turn gauge 2 in accordance with requirement 2.

14.15.03 Stop of the workholder bar

Requirement

The workholder bar must touch along its entire length when in lowered position.

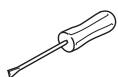
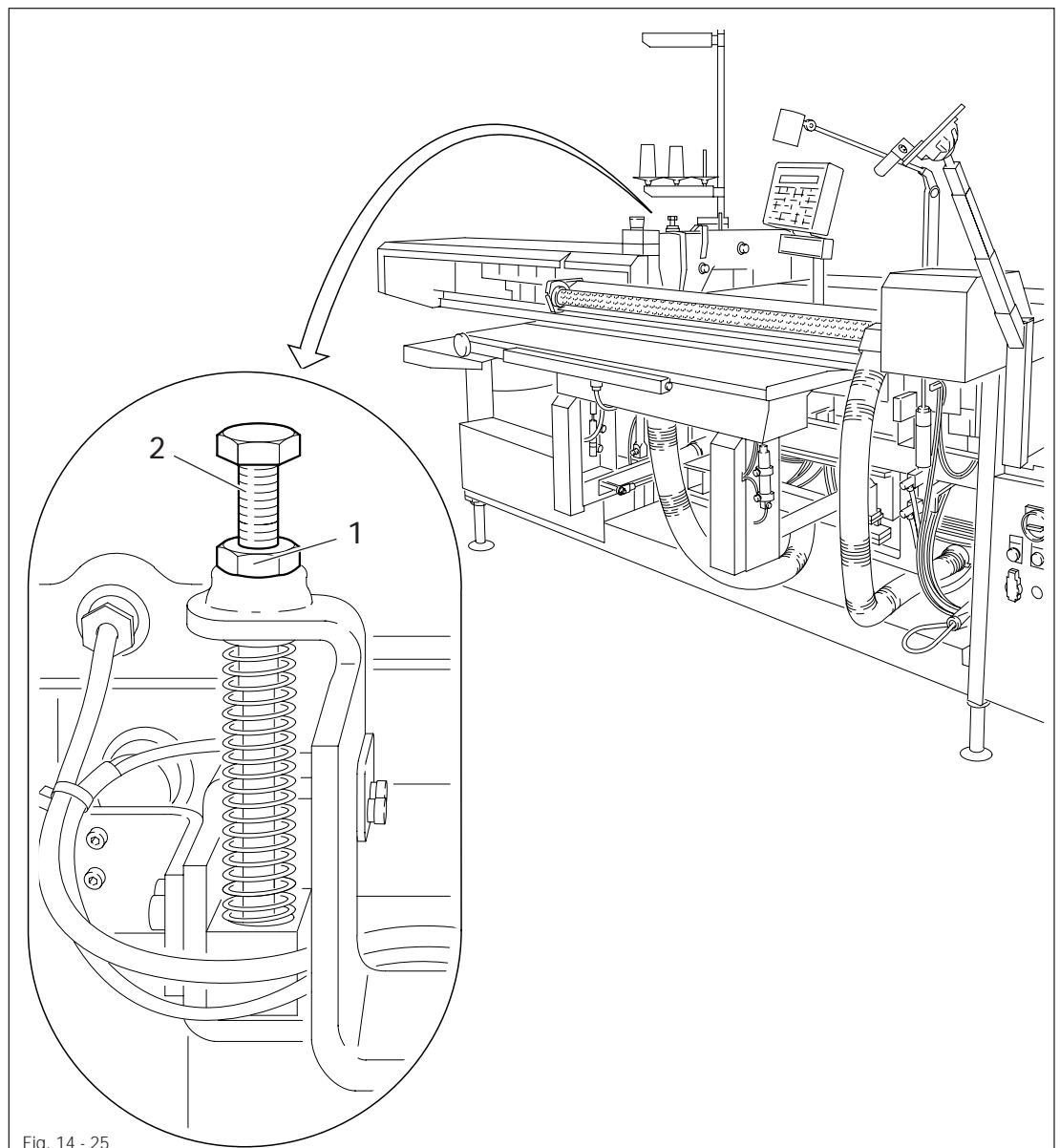

- Loosen nut 1 and turn screw 2 in accordance with the requirement.
- Tighten nut 1.

14.16 Pneumatic table pressure

Requirement

The pressure must be set at approx. 4 bar.

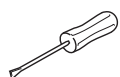
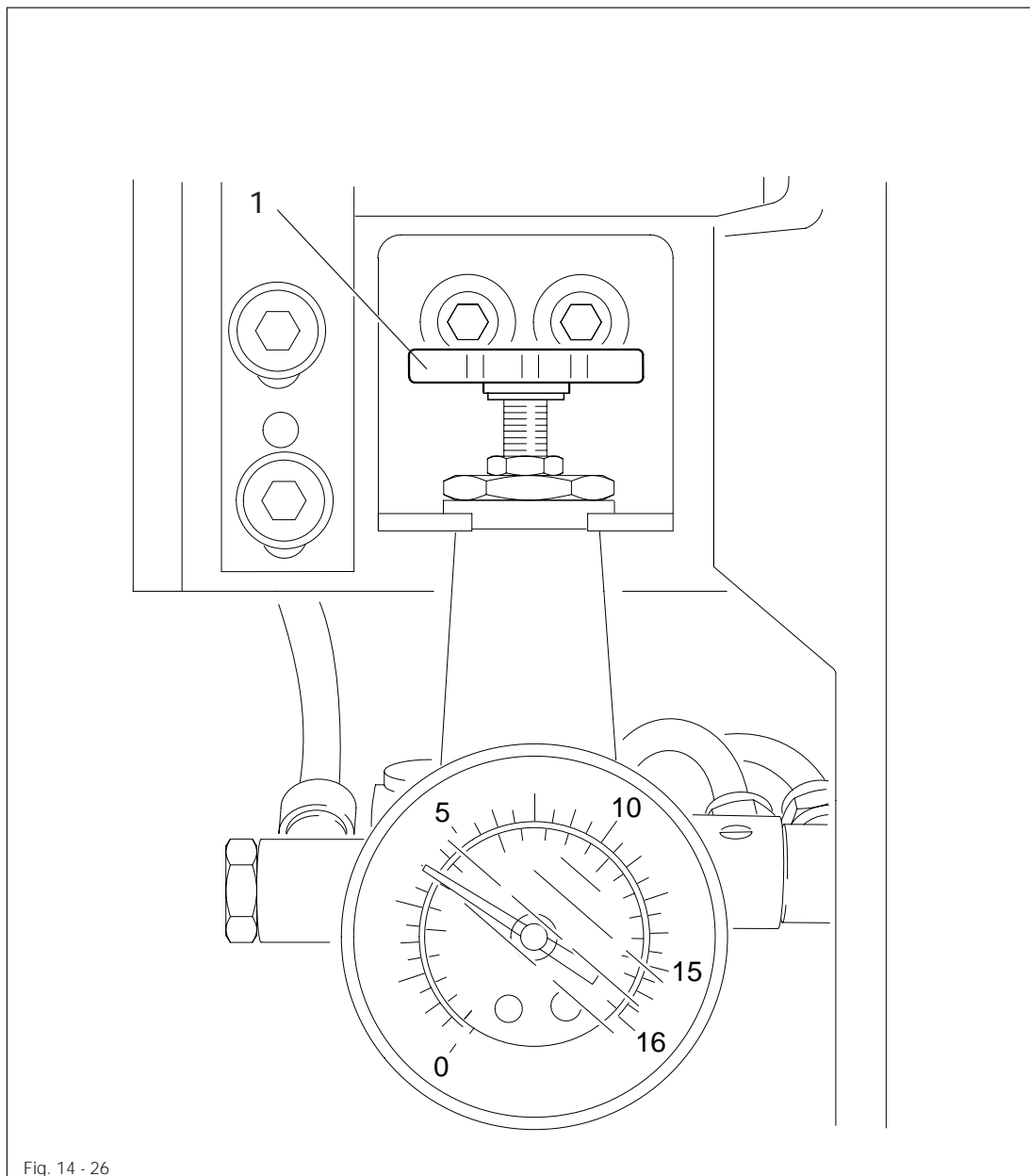

- Turn throttle 1 in accordance with the requirement.

14.17 Pressure monitor

Requirement

A pressure of approx. 4 bar must be set for disengaging.

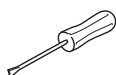
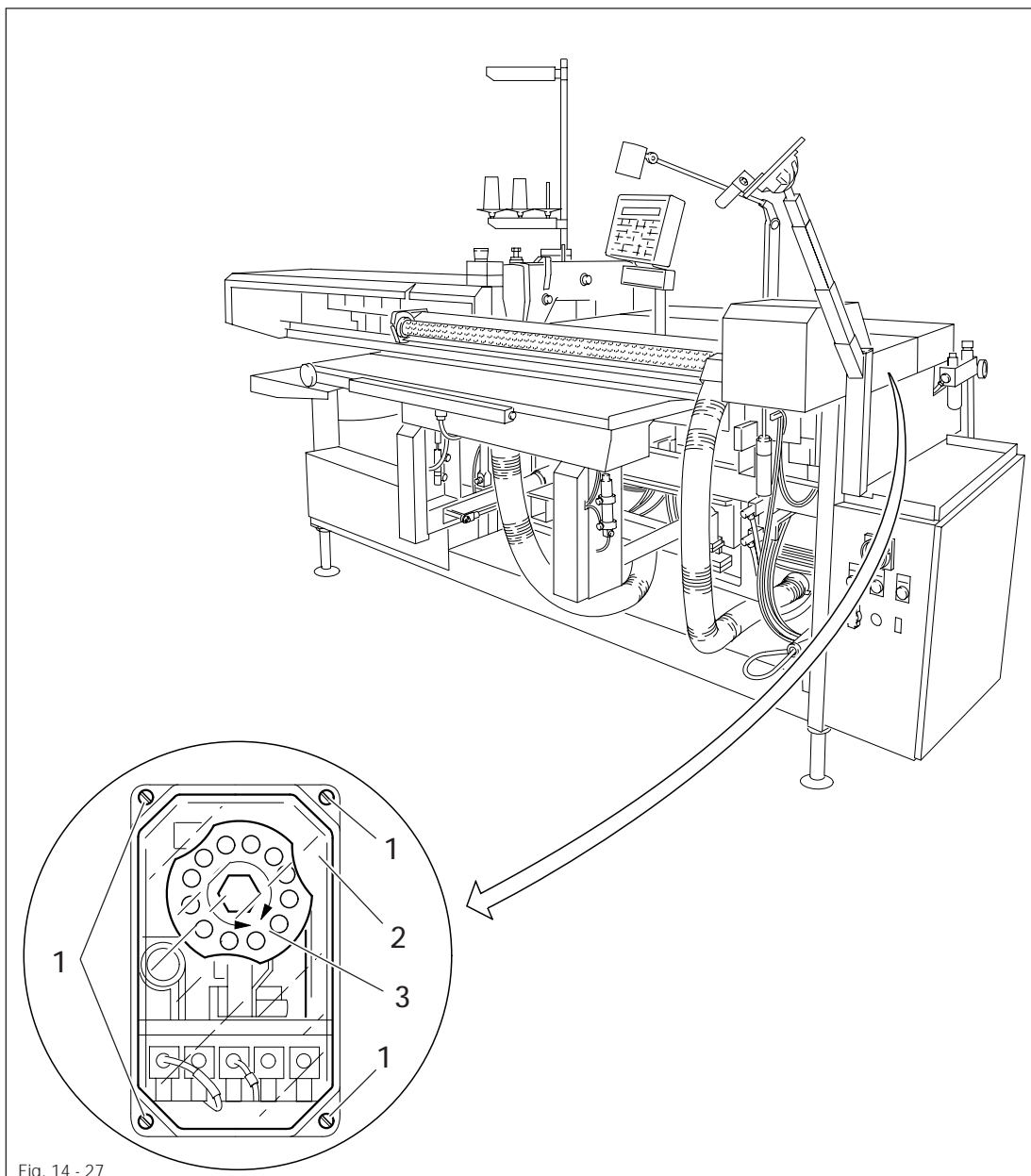

- Loosen screws 1 and remove cover 2.
- Pull grip 3 up and turn in accordance with the requirement.
- Remount cover 2 and tighten screws 1.

14.18 Stacker

Requirement

1. The stacker support must move reliably to its rearmost final position.
2. The stacker must move evenly and reliably to its highest position when loaded.

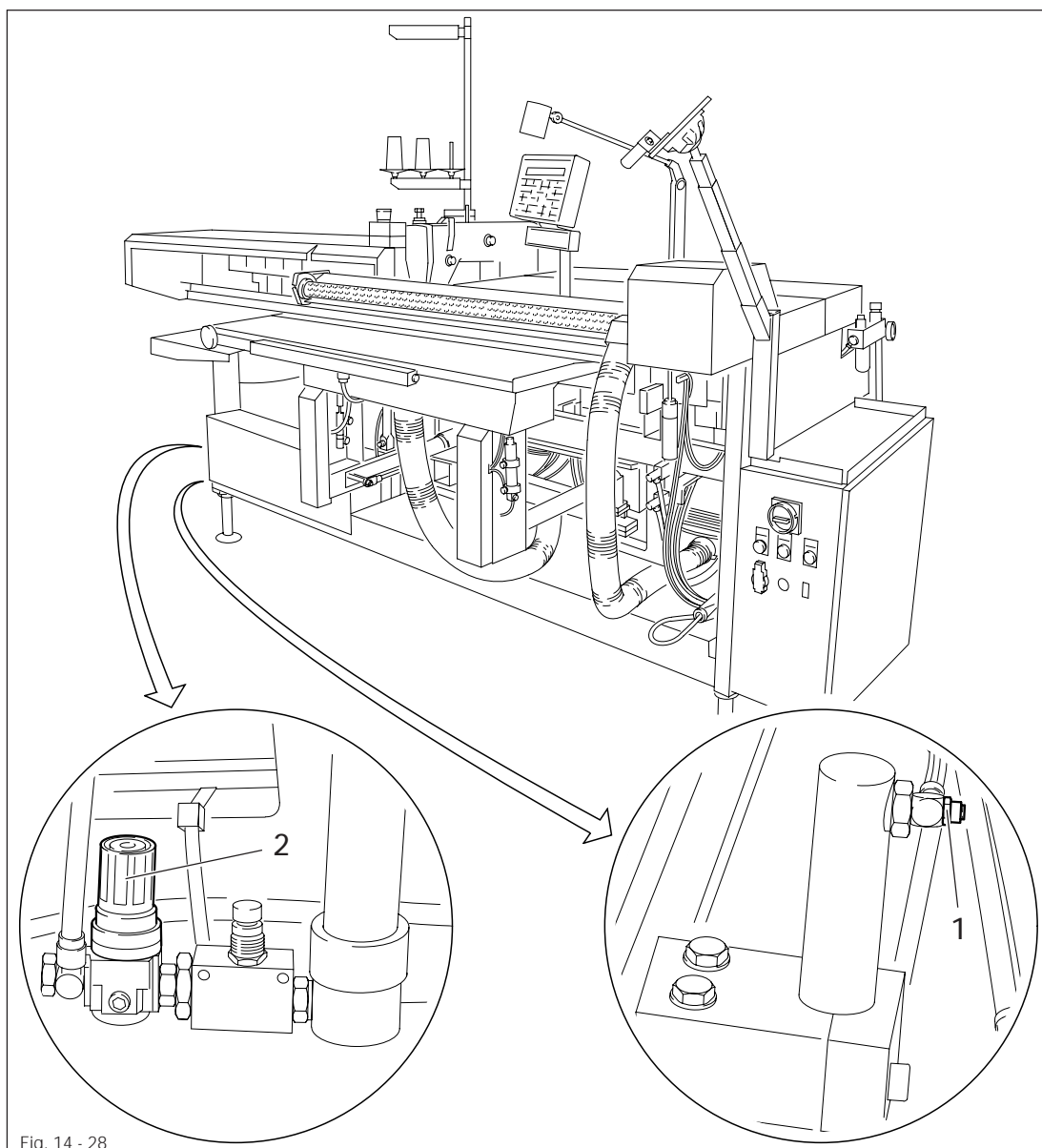
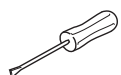

Fig. 14 - 28



- Adjust throttle 1 in accordance with requirement 1.
- Adjust pressure reducer 2 in accordance with requirement 2.

14.19 Checking and adjustment aid for adjusting the sewing head



By blocking holes 1 and 3-6, the required needle positions can be fixed precisely.

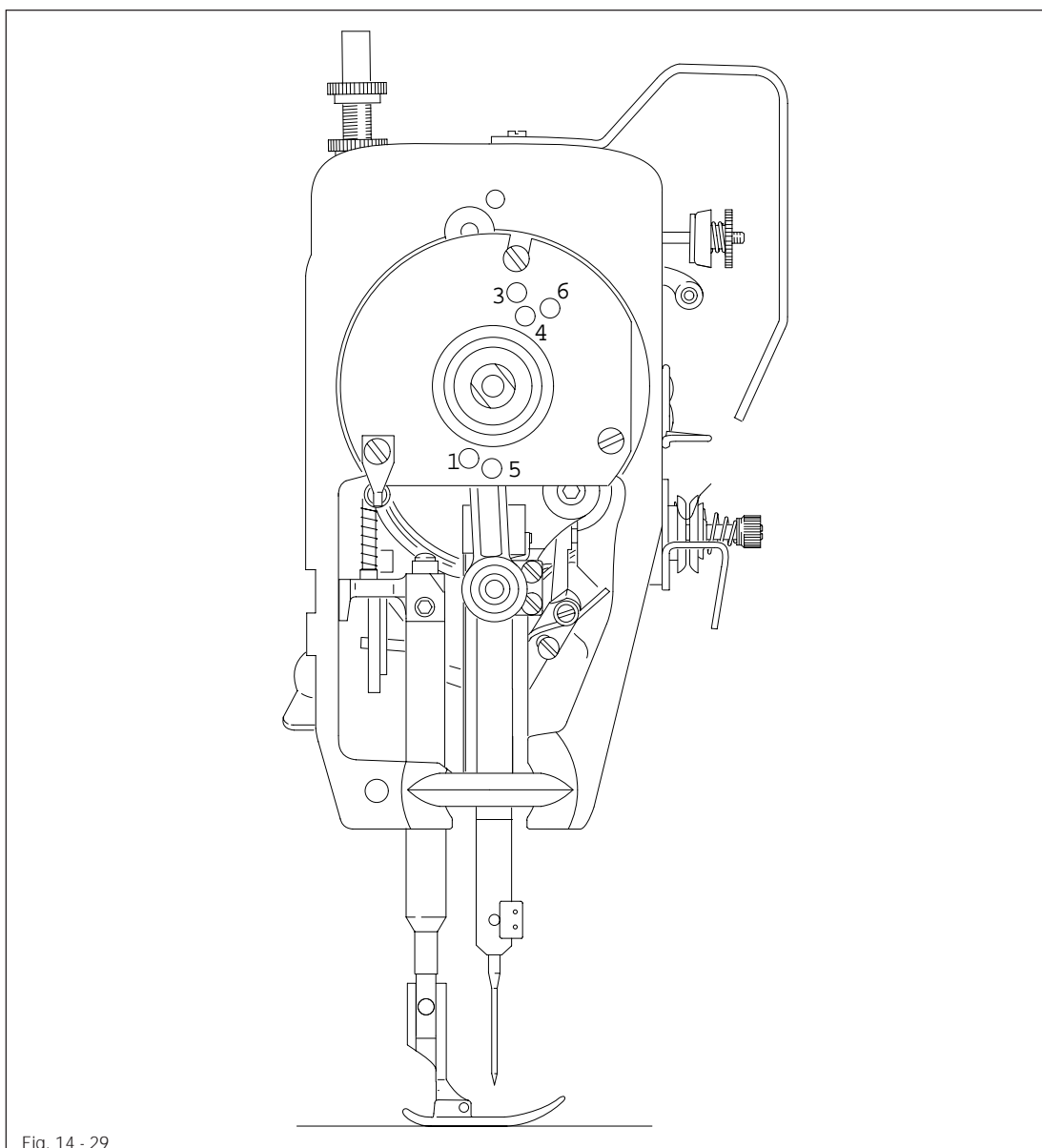
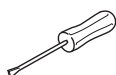

Fig. 14 - 29



- Turn the handwheel until the needle bar is in approximately the required position.
- Place the adjustment pin in the appropriate hole and place under pressure.
- Rotate the handwheel back and forth a little until the adjustment pin grips in the crank slot behind the bearing plate, thus blocking the machine.

Hole 1 = 0.6 mm past the top dead center of the needle bar (0.6 past t.d.c.)

Hole 3 = 0.6 mm past the bottom dead center of the needle bar (0.6 past b.d.c.)

Hole 4 = 1.8 mm past the bottom dead center of the needle bar (needle bar rise)

Hole 5 = Top dead center of the needle bar (t.d.c.)

Hole 6 = 4 mm past the bottom dead center of the needle bar (4 past b.d.c.)

14.20 Pre-adjusting the needle height

Requirement

With the needle bar at its b.d.c., the distance between the needle plate and the bottom edge of the needle bar must be approx. **16.5 mm**.

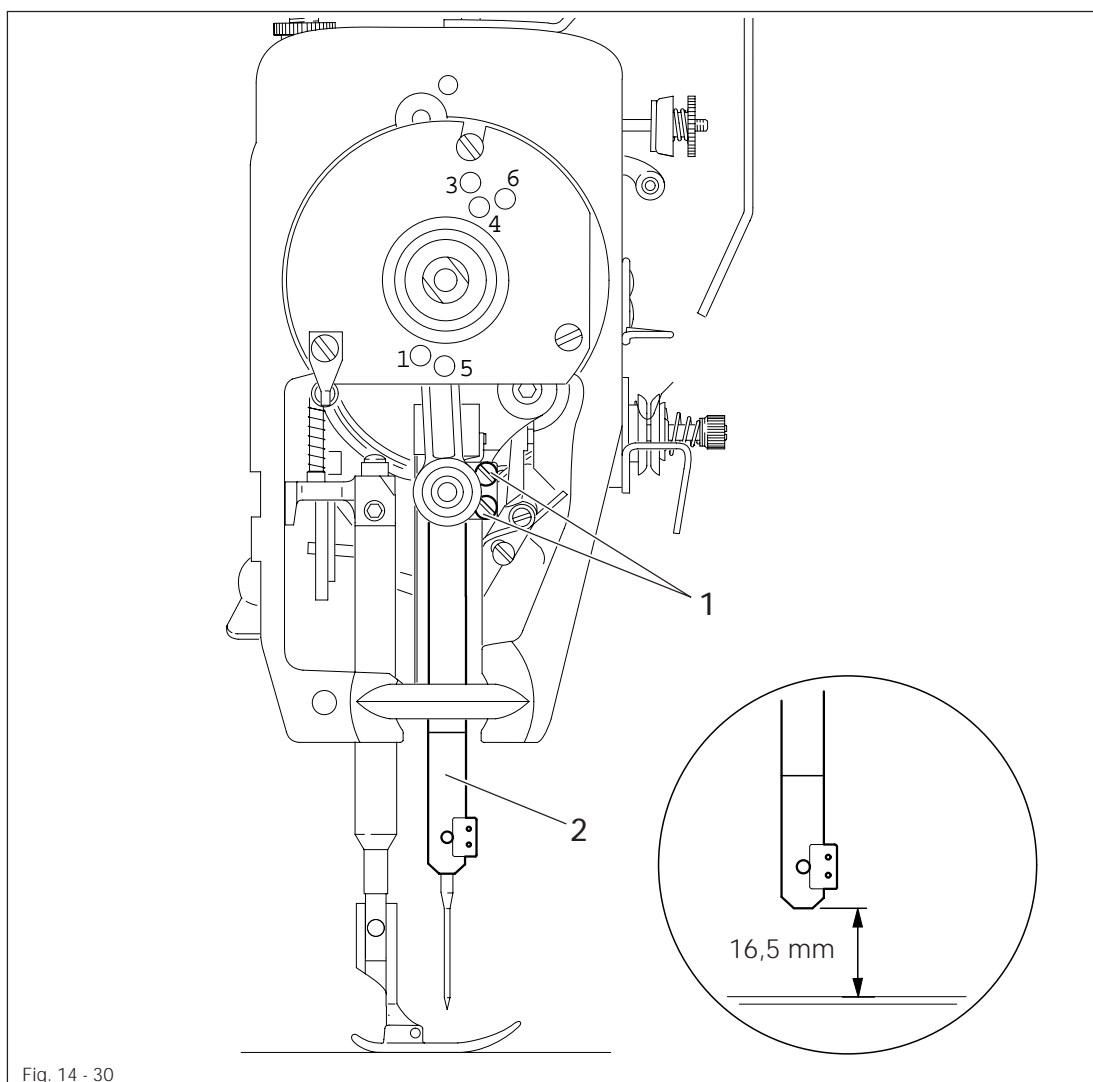
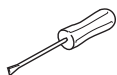

Fig. 14 - 30



- Loosen screws 1.
- Move needle bar 2 in accordance with the **requirement** without twisting it. Take care that the needle retaining screw points to the right as viewed in the direction of feed.
- Tighten screws 1.

14.21 Zeroing the feed dog

Requirement

With the stitch length set at "0", the feed dog should not carry out any feeding motion when the handwheel is turned.

14.21.01 Adjustment with gearbox housing closed

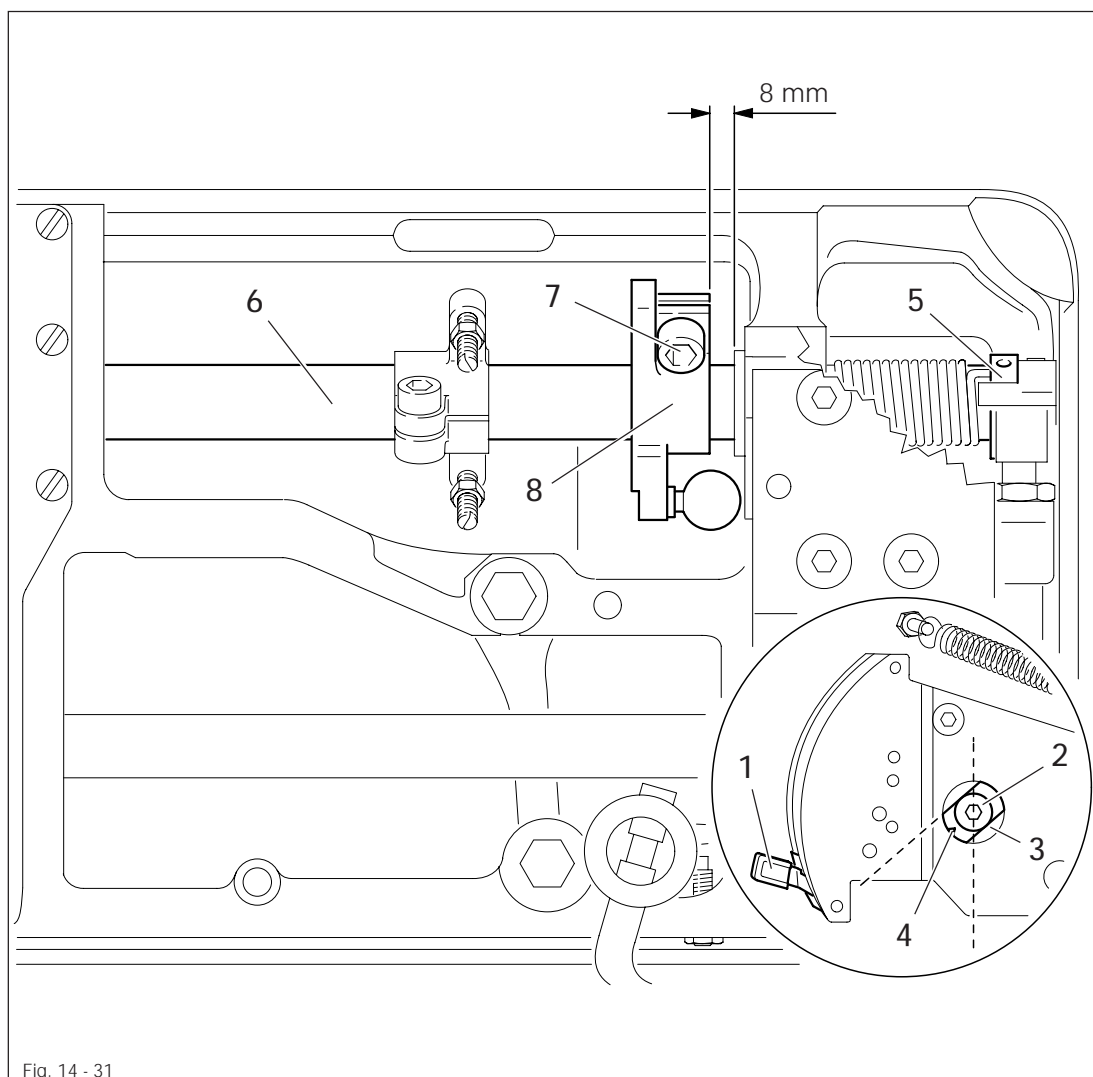
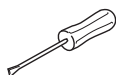

Fig. 14 - 31



- Raise the presser foot and position stitch length adjustment lever 1 at its lowest point.
- Loosen screw 2.
- Turn eccentric bushing 3 so that marking 4 is in the lower section and the edge of the flattened surface is at an angle of approx. 45° to the front of the machine (for adjustments see **Chapter 14.36 Stitch length adaptation**).
- Tighten screw 2.
- Place an Allan key in a hole of tension ring 5 to block shaft 6, then loosen screw 7.
- While constantly turning the handwheel, turn shaft 6 in accordance with the **requirement** with the Allan key. Take care that the distance between bearing bush 8 and adjustment crank 9 always remains at **approx. 8 mm**.
- Tighten screw 7.

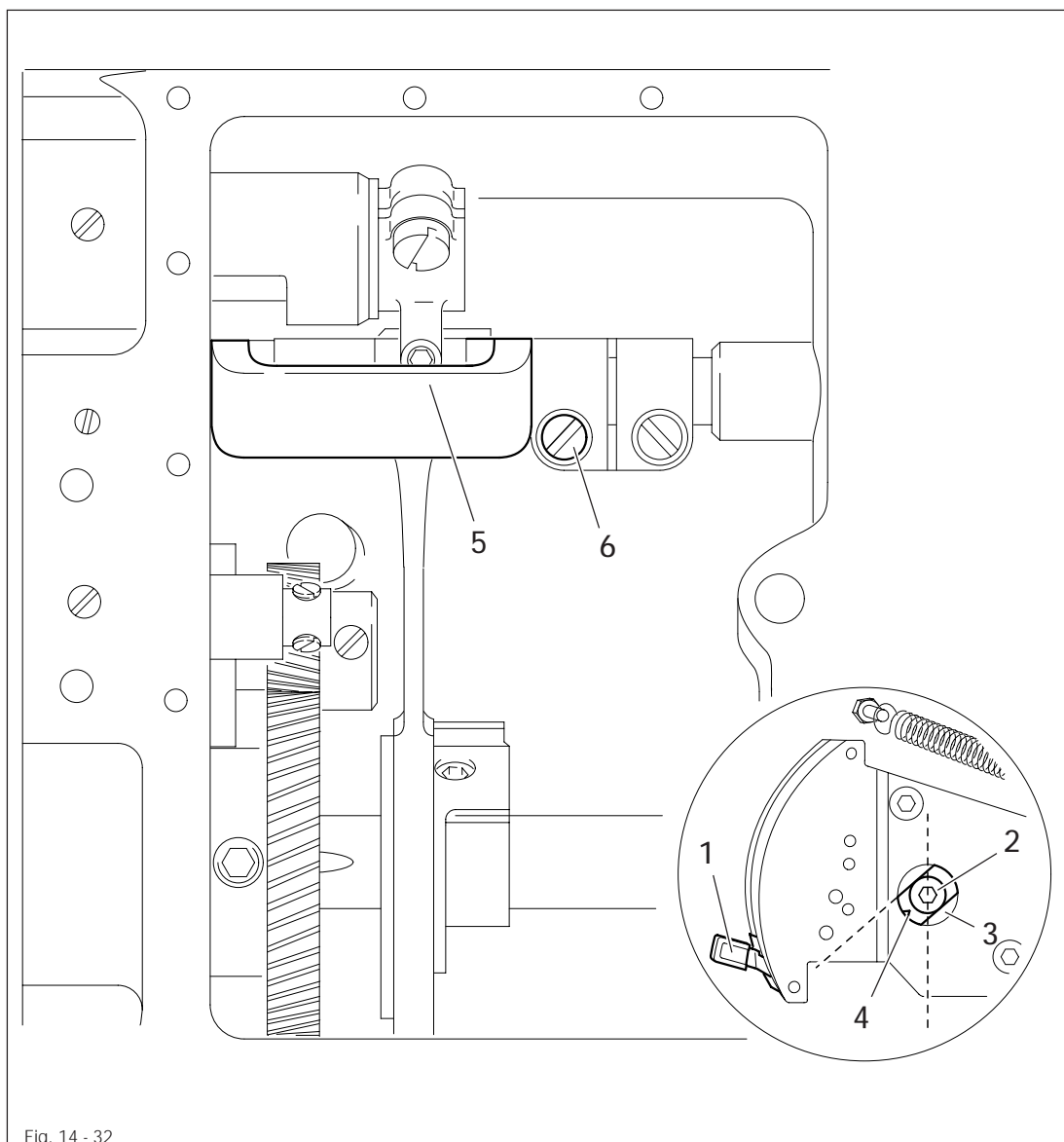
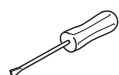

Fig. 14 - 32



- Raise the presser foot and position stitch length adjustment lever 1 at its lowest point.
- Loosen screw 2.
- Turn eccentric bushing 3 so that marking 4 is in the lower section and the edge of the flattened surface is at an angle of approx. 45° to the front of the machine (for adjustments see **Chapter 14.36 Stitch length adaptation**).
- Tighten screw 2.
- Loosen screw 6.
- Turn crank 5 in accordance with the requirement.
- Tighten screw 6.

14.22 Vibrating presser lifting motion

Requirement

With the stitch length set at "0", the vibrating presser must be at its top point of reversal when the needle bar is 0.6 mm past its t.d.c. (hole 1). The cutout of lifting eccentric 1 must stand almost vertically beneath the middle of the axle.

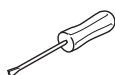
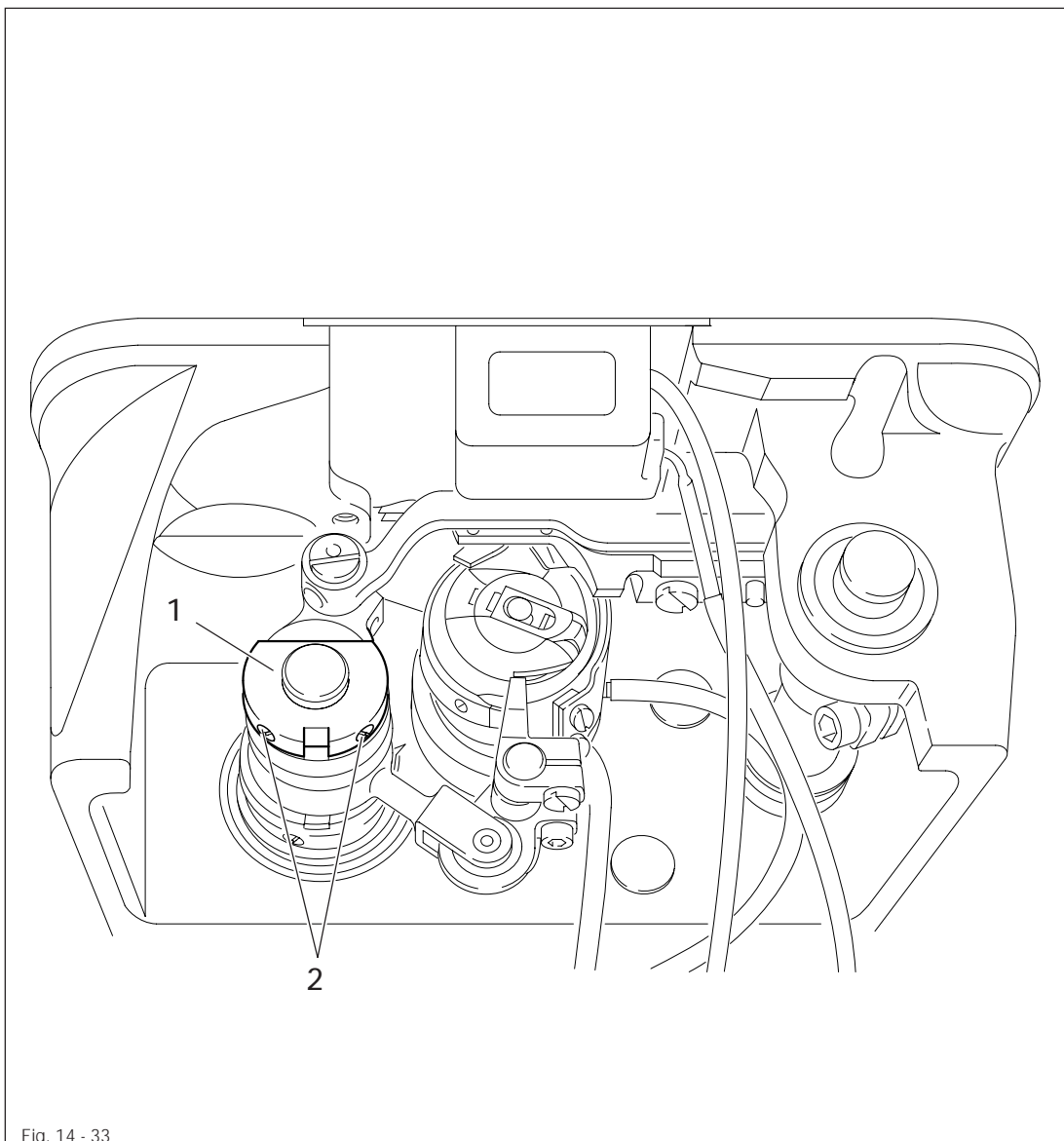

- Loosen screw 2.
- Turn lifting eccentric 1 in accordance with the requirement.
- Tighten screws 2.

14.23 Vibrating presser height

Requirement

With the stitch length set at "0", and the needle bar 0.6 mm past its t.d.c. (hole 1) the vibrating presser must:

1. be in the center of the needle plate cutout, both laterally and in the direction of feed.
2. be at its top point of reversal and touch the adjustment gauge along its entire length.
3. be 0.3 mm beneath the needle plate when lowered.

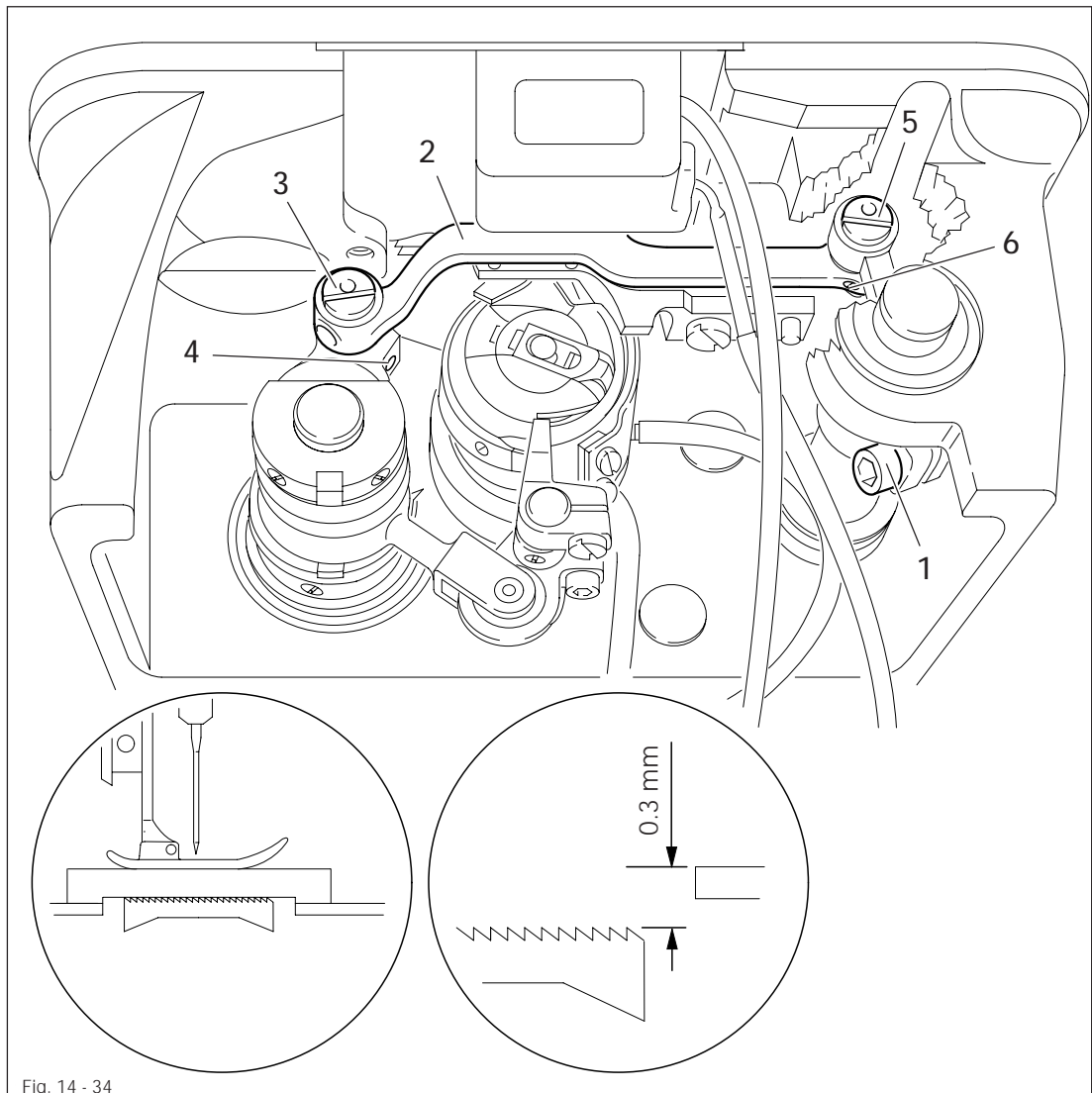
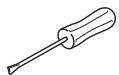

Fig. 14 - 34



- Loosen screw 1.
- Move vibrating presser carrier 2 in accordance with requirement 1.
- Tighten screw 1.
- Lower the presser foot onto the gauge.
- Loosen screws 3 and 5.
- Turn eccentrics 4 and 6 in accordance with requirement 2.
- Tighten screws 3 and 5.

14.24 Vibrating presser feeding motion

Requirement

At the longest stitch length setting and with the needle bar 0.6 mm past t.d.c. (hole 1), the vibrating presser must not move when the reverse feed key is pressed.

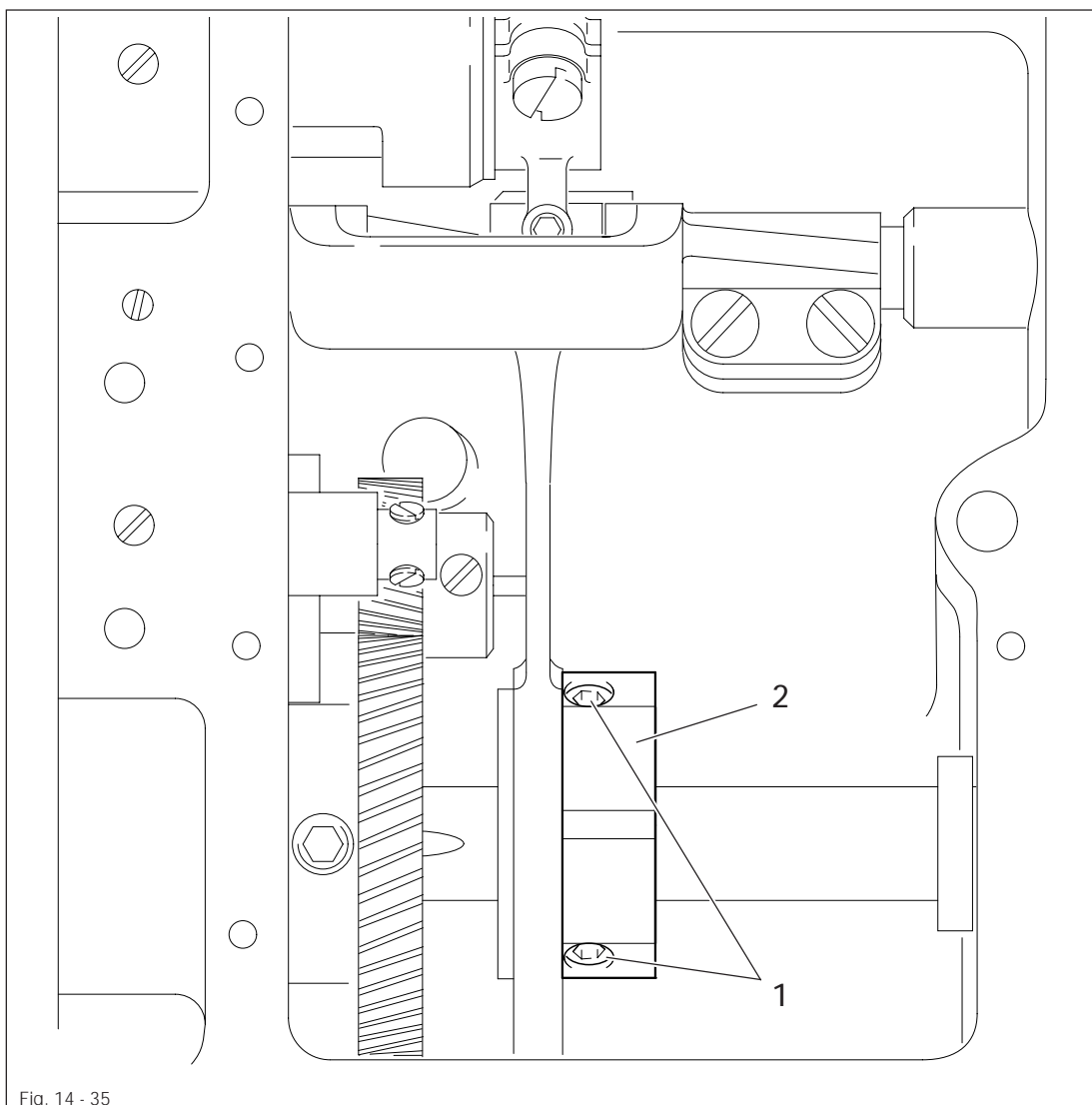
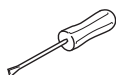

Fig. 14 - 35



- Loosen screw 1.
- Turn feed eccentric 2 in accordance with the **requirement**. Take care to ensure that the cutout in feed eccentric 2 is visible.
- Tighten screws 1.

14.25 Centering the needle in the needle hole

Requirement

The needle must enter the needle hole exactly in the middle.

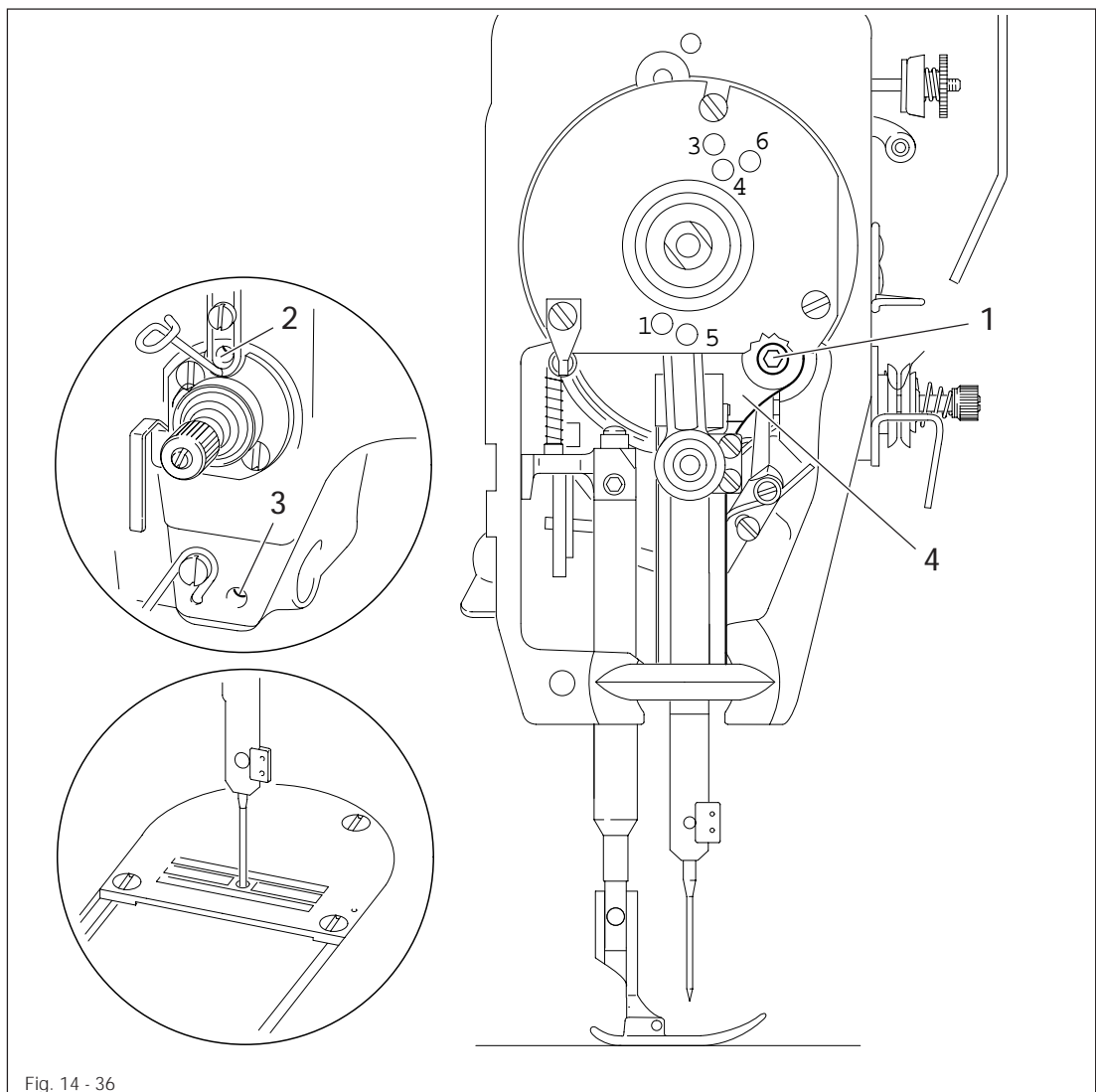
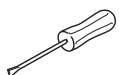

Fig. 14 - 36



- Position the needle directly above the needle hole.
- Loosen screws 1, 2 and 3.
- Move needle bar frame 4 both in and across the direction of sewing in accordance with the **requirement** and tighten screw 2 lightly and tighten screw 3.
- Pull the guide stud against the eye of the needle bar frame using screw 1 and tighten it.
- Turn the handwheel a few rotations so that the needle bar frame does not twist and tighten screw 2.

Requirement

1. The slot in bearing 3 (see arrow) must be visible from below and there must be a minimal but noticeable play between gear wheels 5 and 7.
2. With the hook lightly touching overspeed disk 4 and the hook point pointing to the middle of the needle, there must be a distance of less than 0.1 mm between the hook point and the scarf.
3. Gear wheel 5 must be aligned with gear wheel 7.

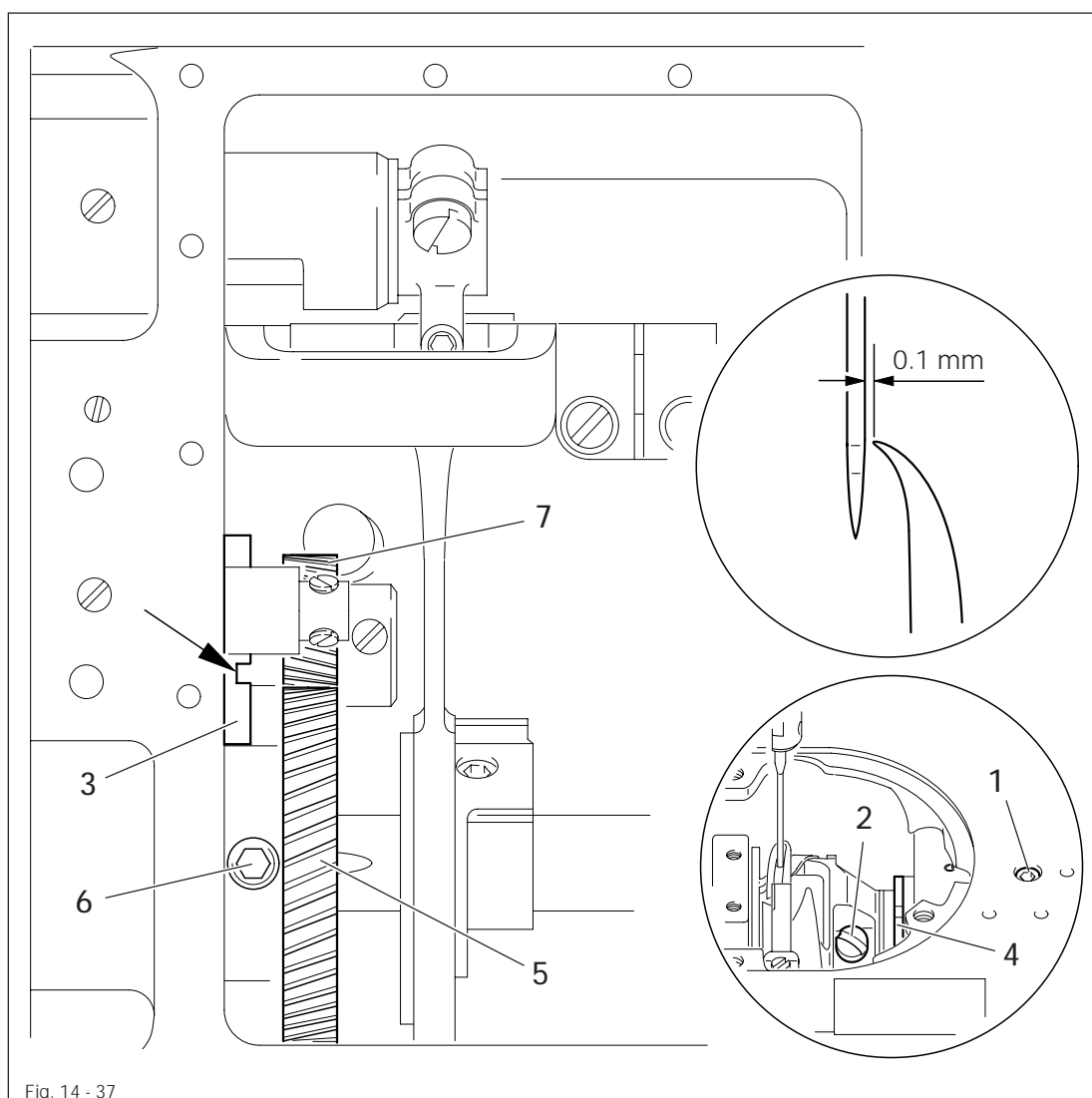
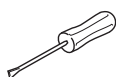

Fig. 14 - 37



- Loosen screws 1 and 2.
- Turn bearing 3 in accordance with **requirement 1**.
- Bring the hook to rest against overspeed disk 4, move bearing 3 in accordance with **requirement 2** without twisting it and tighten screws 1 and 2.
- Loosen screws 6.
- Move gear wheel 5 in accordance with **requirement 3**.
- Tighten screws 6.

14.27 Final adjustment of needle rise and needle height and bobbin case position finger

Requirement

With the stitch length set at "0" and the needle bar 1.8 mm past b.d.c. (hole 4):

1. the hook point must be at the middle of the needle and the top edge of the needle eye must be 0.8 mm underneath the hook point and
2. there must be a distance of 0.5 mm between the lug of position stop 3 and the bottom of the stop lug.

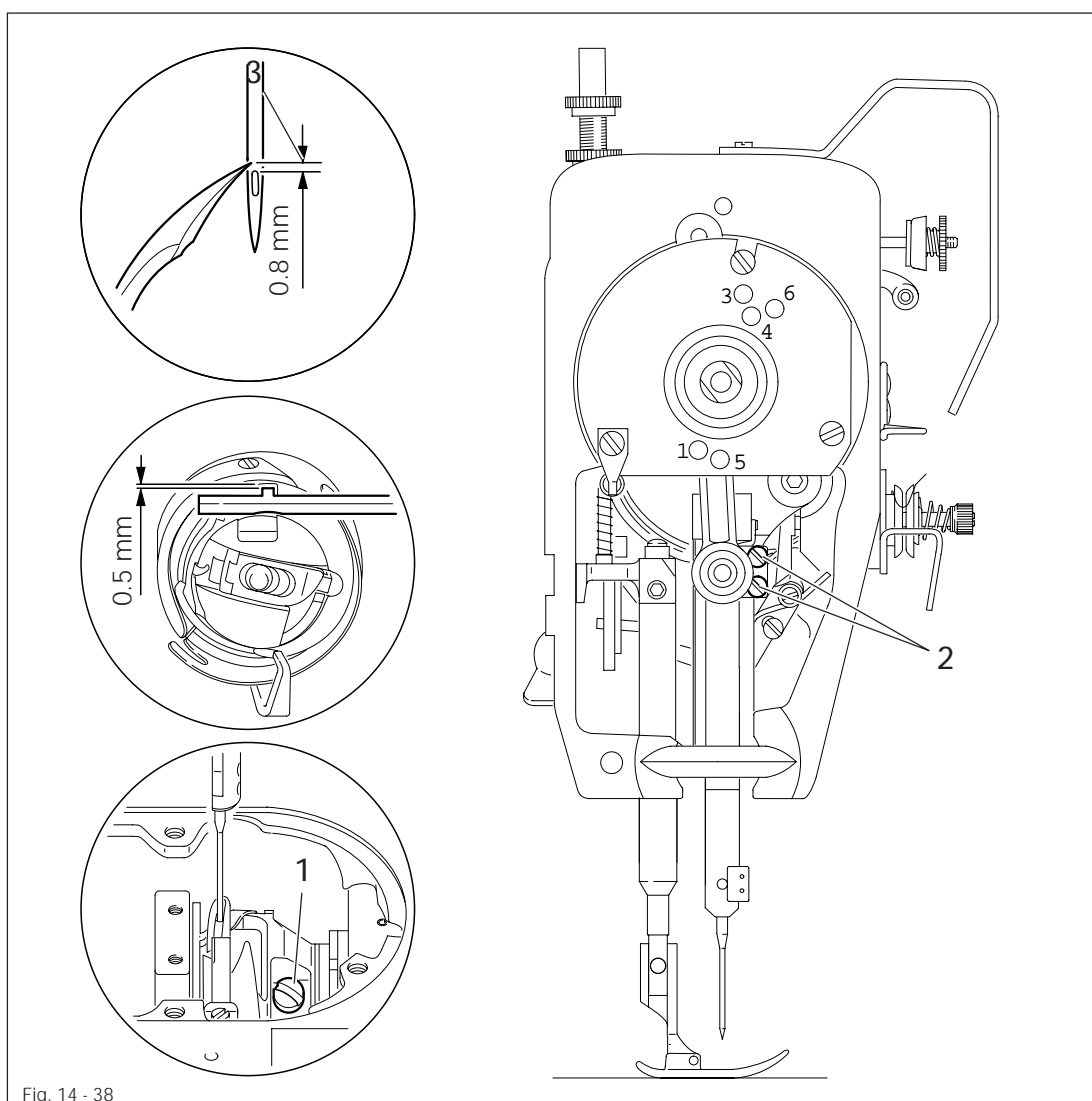
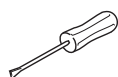

Fig. 14 - 38



- Loosen screws 1 and 2.
- Adjust the hook without moving it and the needle bar without turning it, in accordance with requirement 1.
- Tighten screws 1 and 2.
- Place the lug of position stop 3 in the slot of the bobbin case carrier and move and affix it in accordance with requirement 2.

14.28 Bobbin case opener height

Requirement

At the left point of reversal of bobbin case opener 3, the top edge of its finger must be 0.5 mm above the bottom edge of bobbin case trip 4.

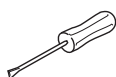
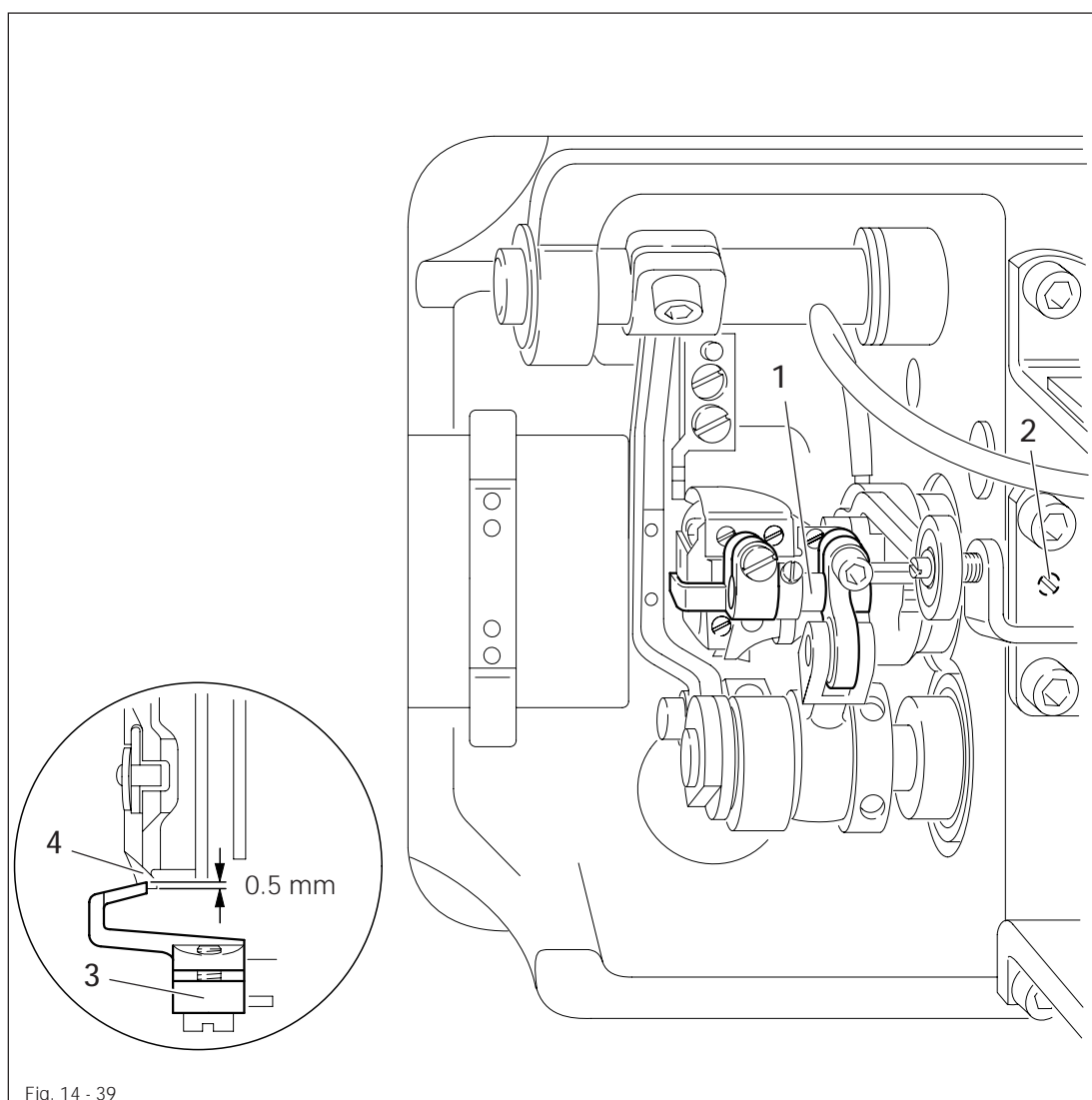

- Loosen screw 2.
- Move bobbin case opener bearing 1 in accordance with the requirement.
- Tighten screw 2.

14.29 Bobbin case opener position

Requirement

1. At the left point of reversal of bobbin case opener 1, the front edge of its finger must be approx. 0.6 mm behind the front edge of bobbin case trip 5.
2. At the left point of reversal of bobbin case opener 1, bobbin case carrier 4 must be approx. 0.3 mm from position finger 7 and screw 3 must touch stop pin 6.

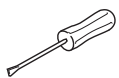
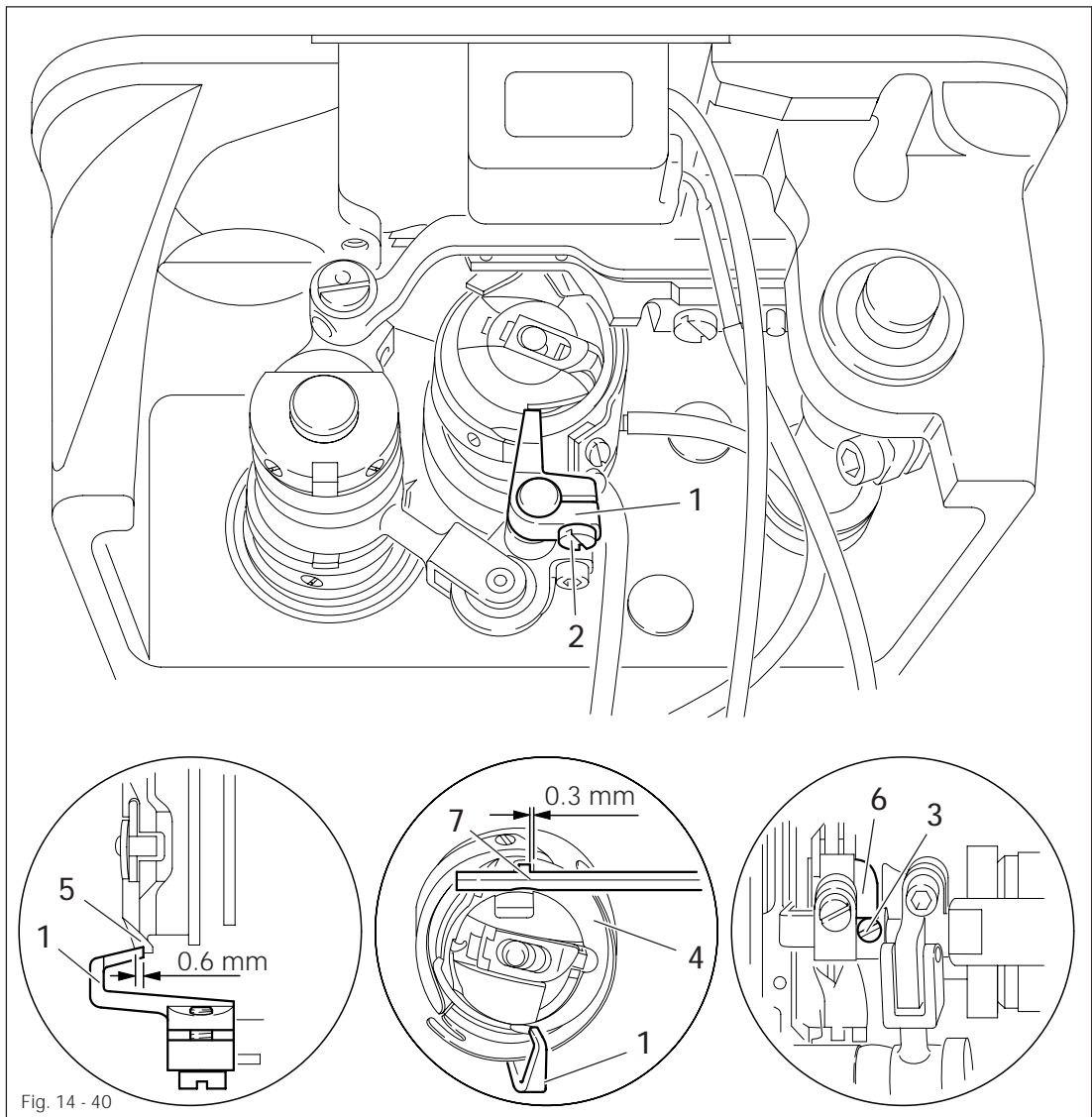

- Loosen screw 3 and loosen screw 2 so that bobbin case opener 1 is still lightly clamped.
- Move bobbin case opener 1 in accordance with requirement 1.
- Tighten screw 2.
- Adjust fixing collar 4 in accordance with requirement 2.
- Tighten screw 3.

14.30 Bobbin case opener motion

Requirement

With the needle bar 1.8 mm past b.d.c. (hole 4), bobbin case opener 3 must be at its right point of reversal.

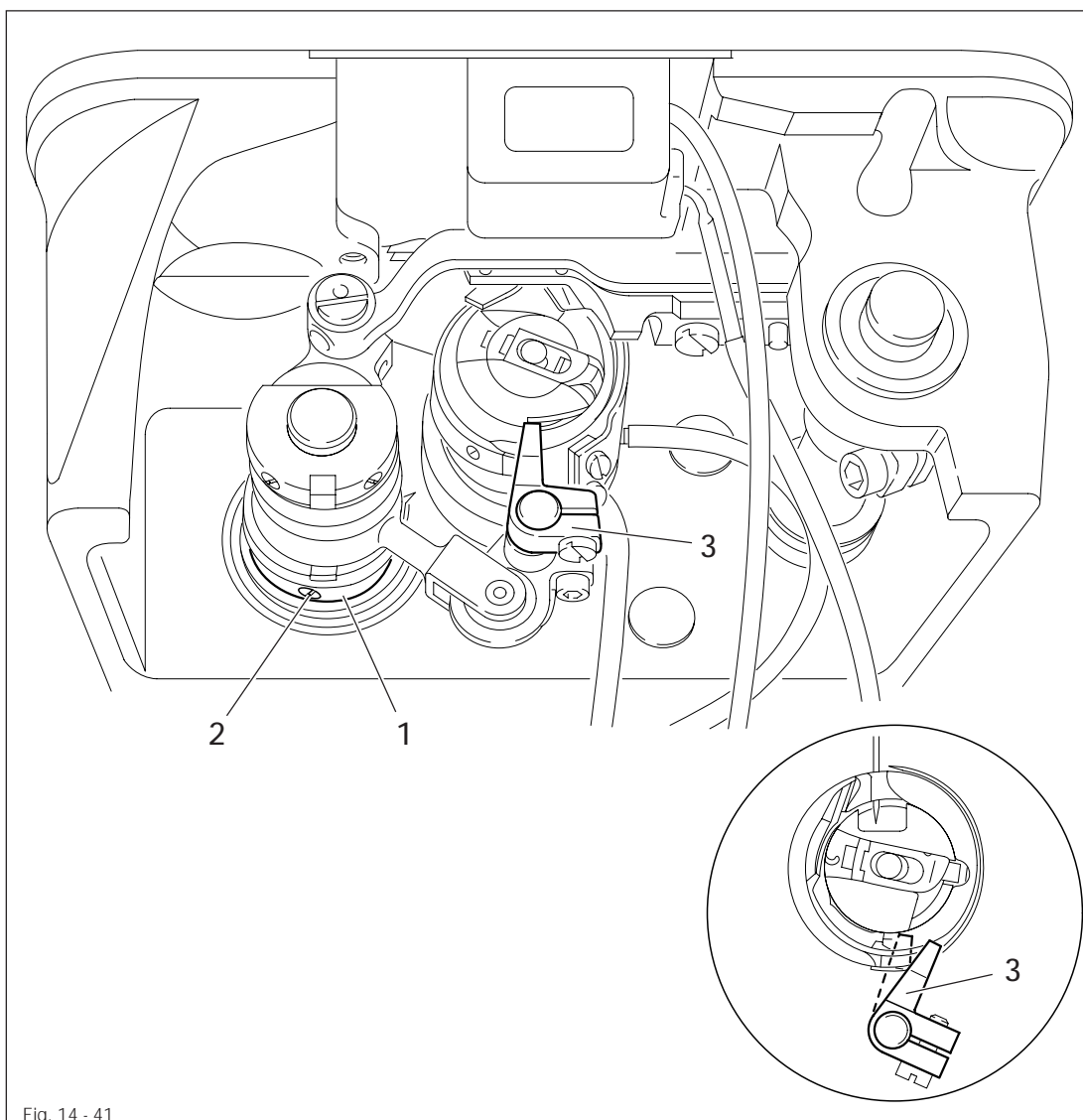
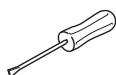

Fig. 14 - 41



- Tighten screws 2.
- Adjust bobbin case opener eccentric 1 in accordance with the requirement.
- Tighten screws 2.



For ease of recognition, a screwdriver can be placed in the clamp slot of bobbin case opener 3.

14.31 Clearance between presser foot and needle plate

Requirement

With hand lever 1 raised there must be a clearance between the presser foot and the needle plate of 5 mm.

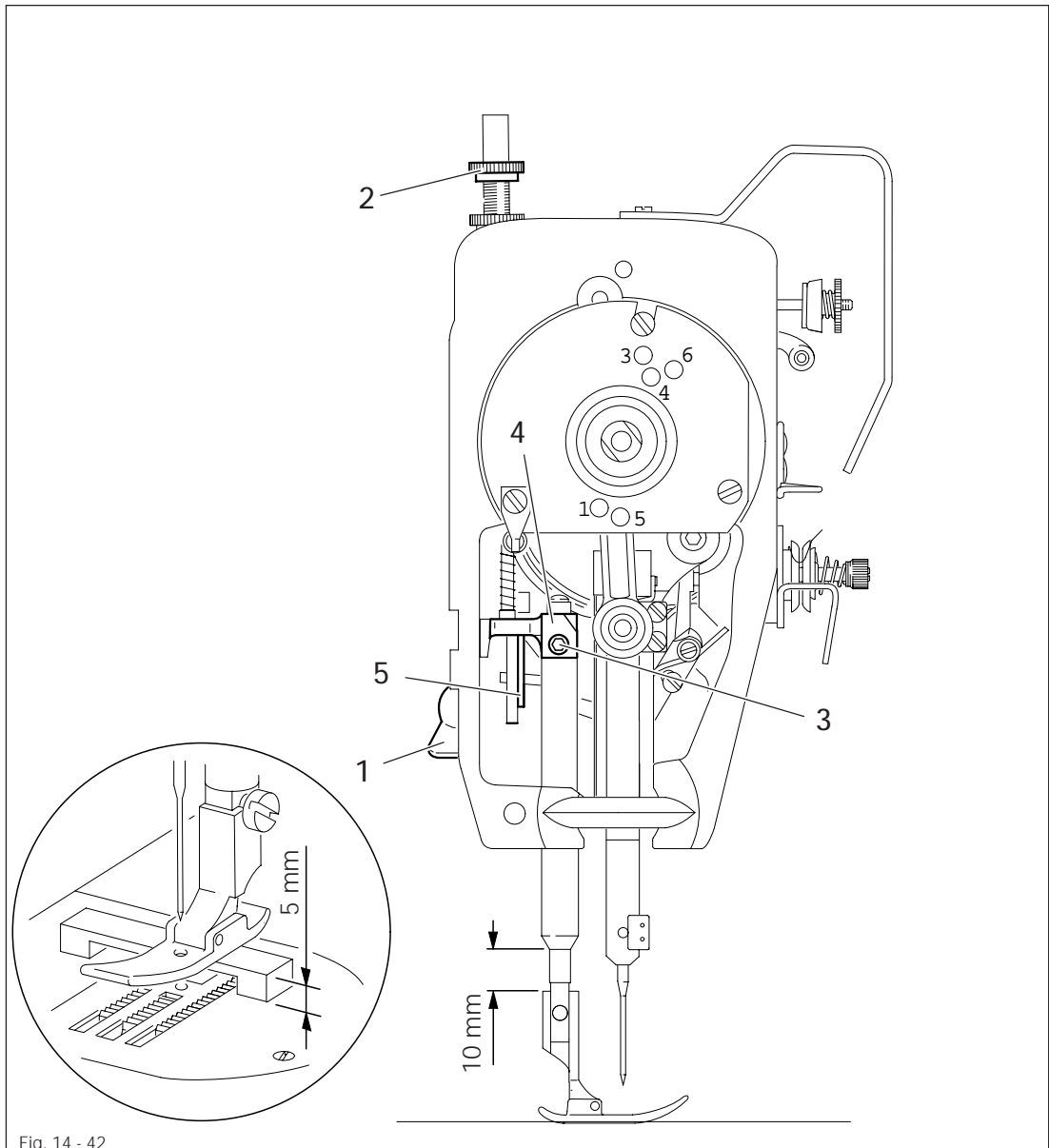
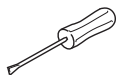

Fig. 14 - 42



- Bring the presser foot to rest on the needle plate using hand lever 1.
- Reduce the pressure on the presser bar by screwing out regulating screw 2.
- Place the 5 mm thick section of the adjustment gauge under the presser foot joint.
- Loosen screw 3 and raise hand lever 1.
- Allow the needle to enter into the needle hole of the presser foot and align the presser foot so that the needle is in the center of the needle hole of the presser foot.
- Press lifting piece 4 down onto the raised presser bar lifting lever 5 and tighten screw 3.
- Remove the adjustment gauge and allow the presser foot to rest on the needle plate.

14.32 Needle thread tension release

Requirement

With hand lever 1 raised, the tension disks must be at least 0.5 mm apart.

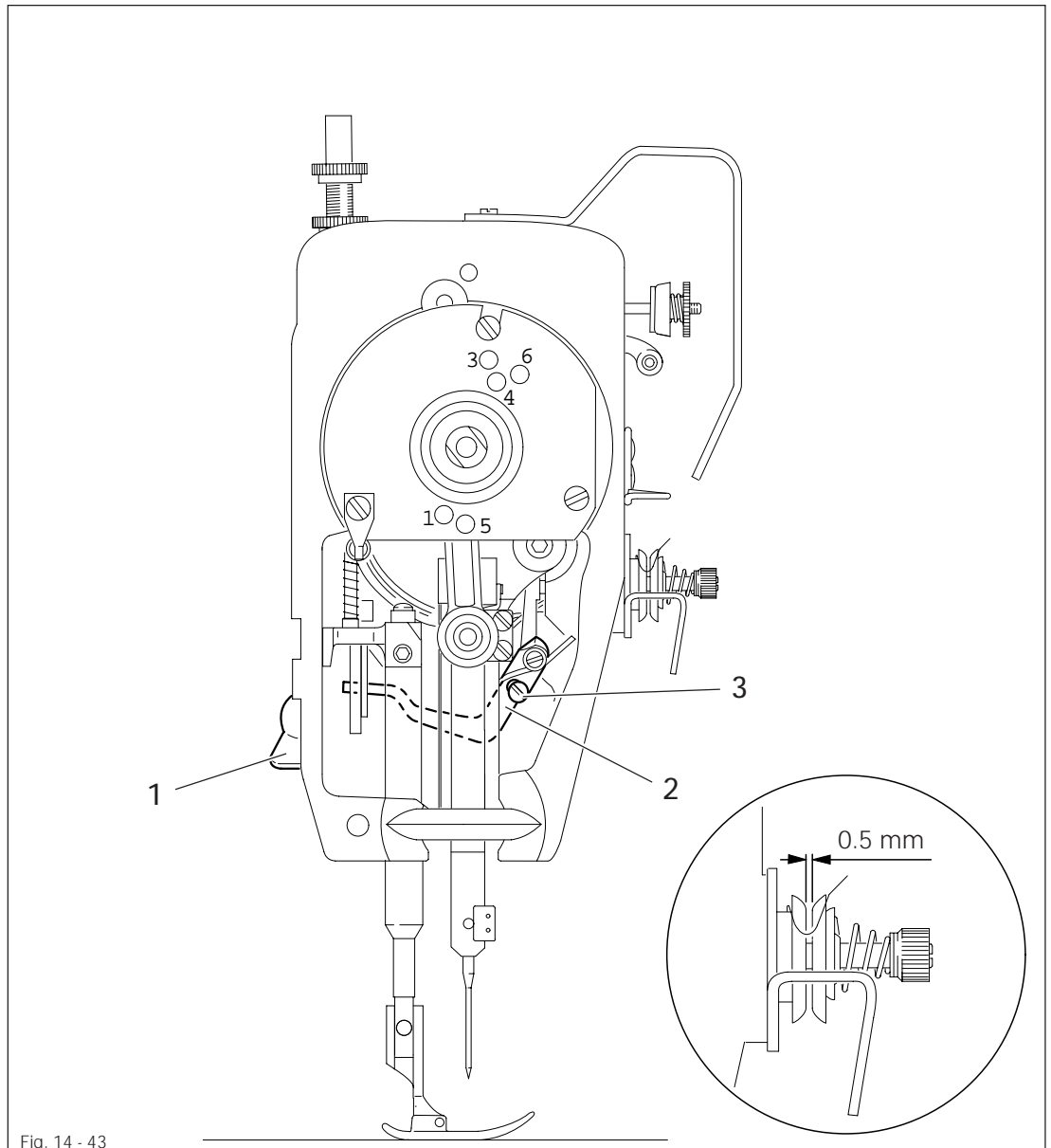
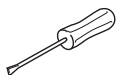

Fig. 14 - 43



- Loosen screw 3.
- Adjust tension release bar 2 in accordance with the requirement.
- Allow the presser foot to rest on the needle plate; the tension must now be fully active.
- Tighten screw 3.

14.33 Thread check spring and slack thread regulator

Requirement

1. The stroke of thread check spring 3 must be finished when the needle point enters the fabric (spring stroke approx. 7 mm).
2. Slack thread regulator 4 must be affixed in its elongated hole in such a way that thread check spring 3 moves approx. 1 mm until the thread loop from the hook is at its largest.

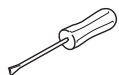
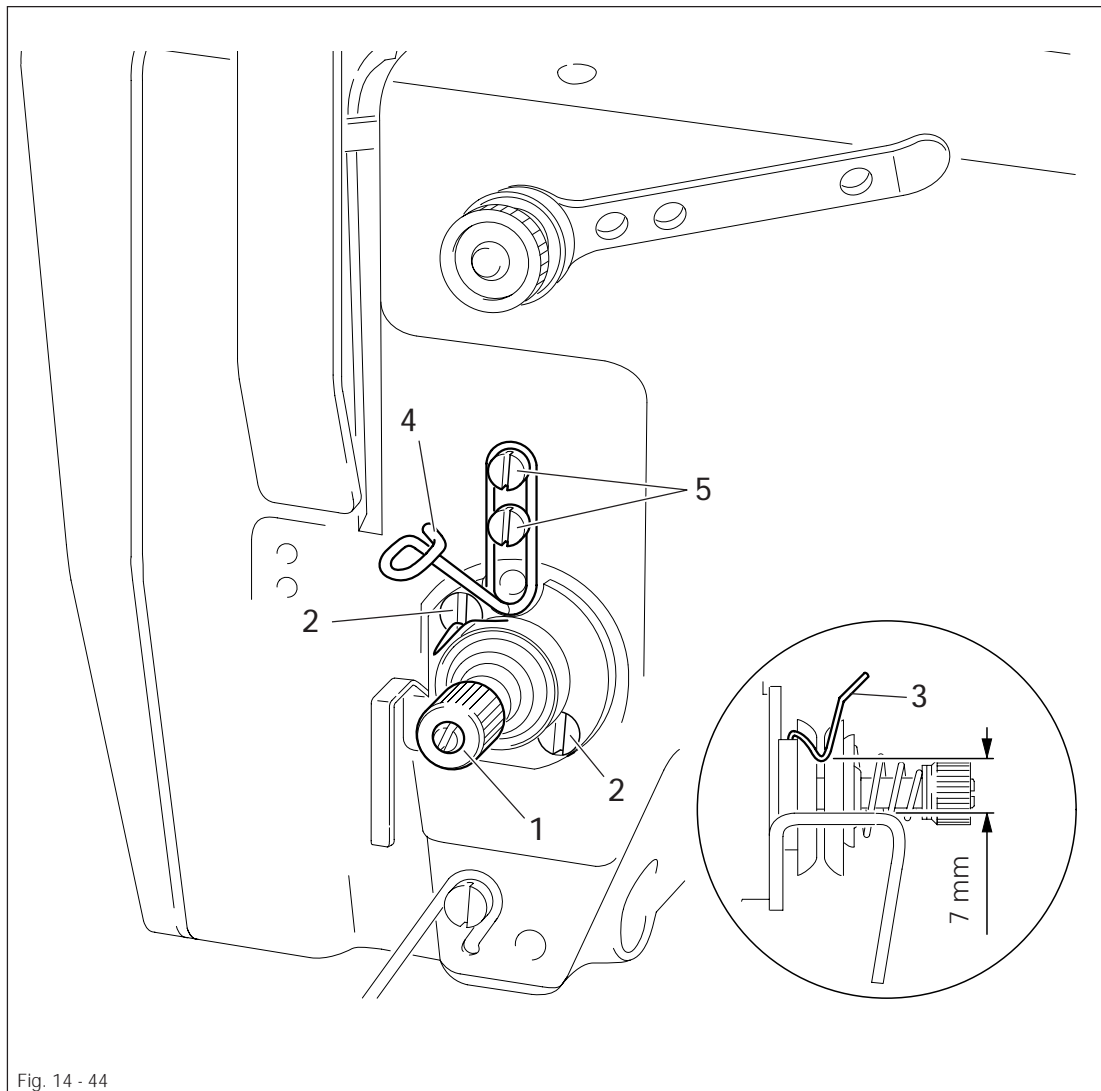

- Loosen screws 2.
- Turn thread tension 1 in accordance with requirement 1.
- Tighten screw 2.
- Loosen screw 5.
- Move slack thread regulator 4 in accordance with requirement 2.
- Tighten screws 5.



The stroke of thread check spring 3 and the position of slack thread regulator 4 is dependent on the fabric and the thread and must be corrected in accordance with the sewing result.

14.34 Bobbin winder

Requirement

1. With the bobbin winder engaged, the bobbin winder spindle must be engaged reliably and friction wheel 3 must not touch drive wheel 1 when the bobbin winder is disengaged.
2. The bobbin winder must disengage automatically when the thread level is approx. 1 mm from the edge of the bobbin.

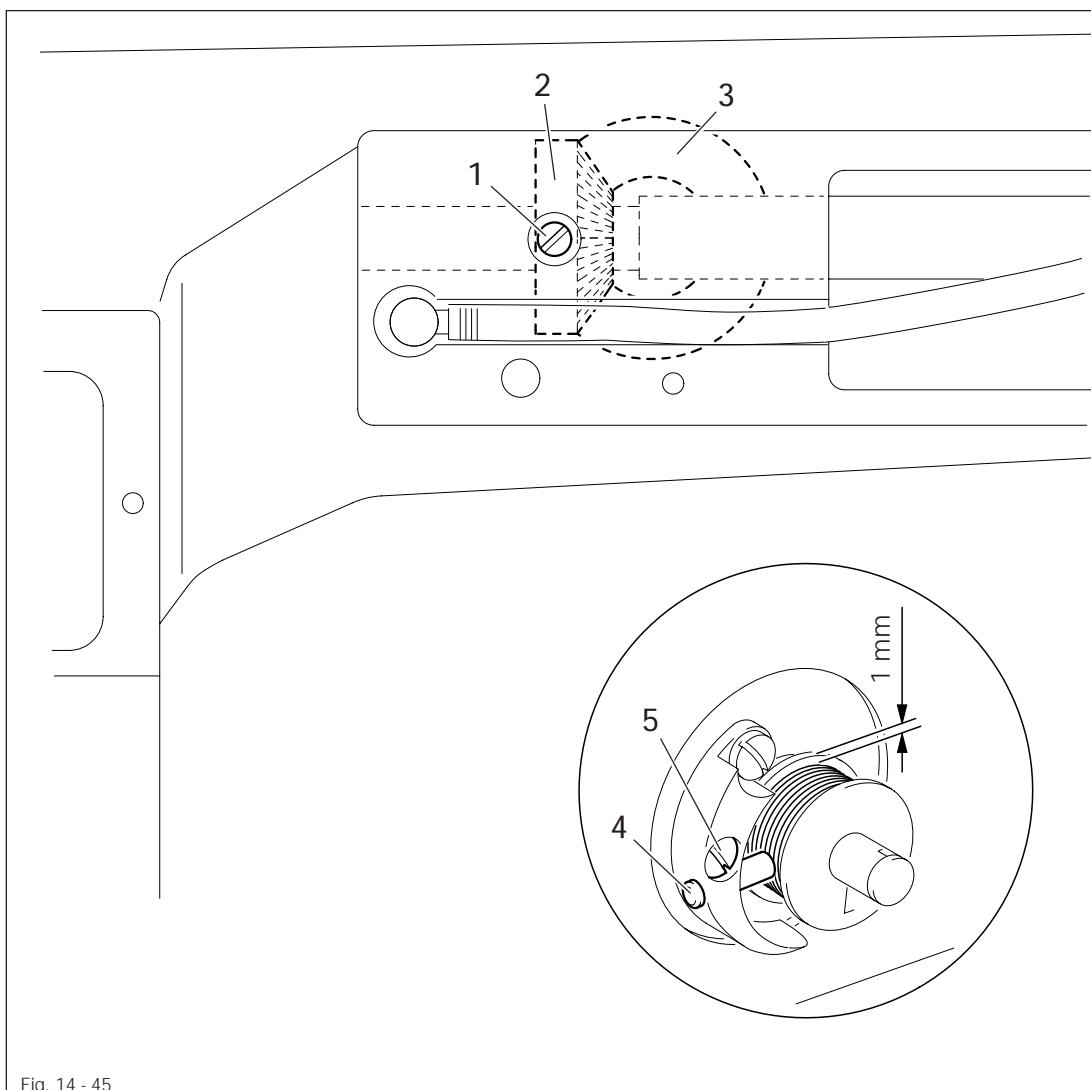
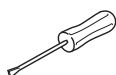
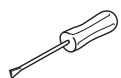
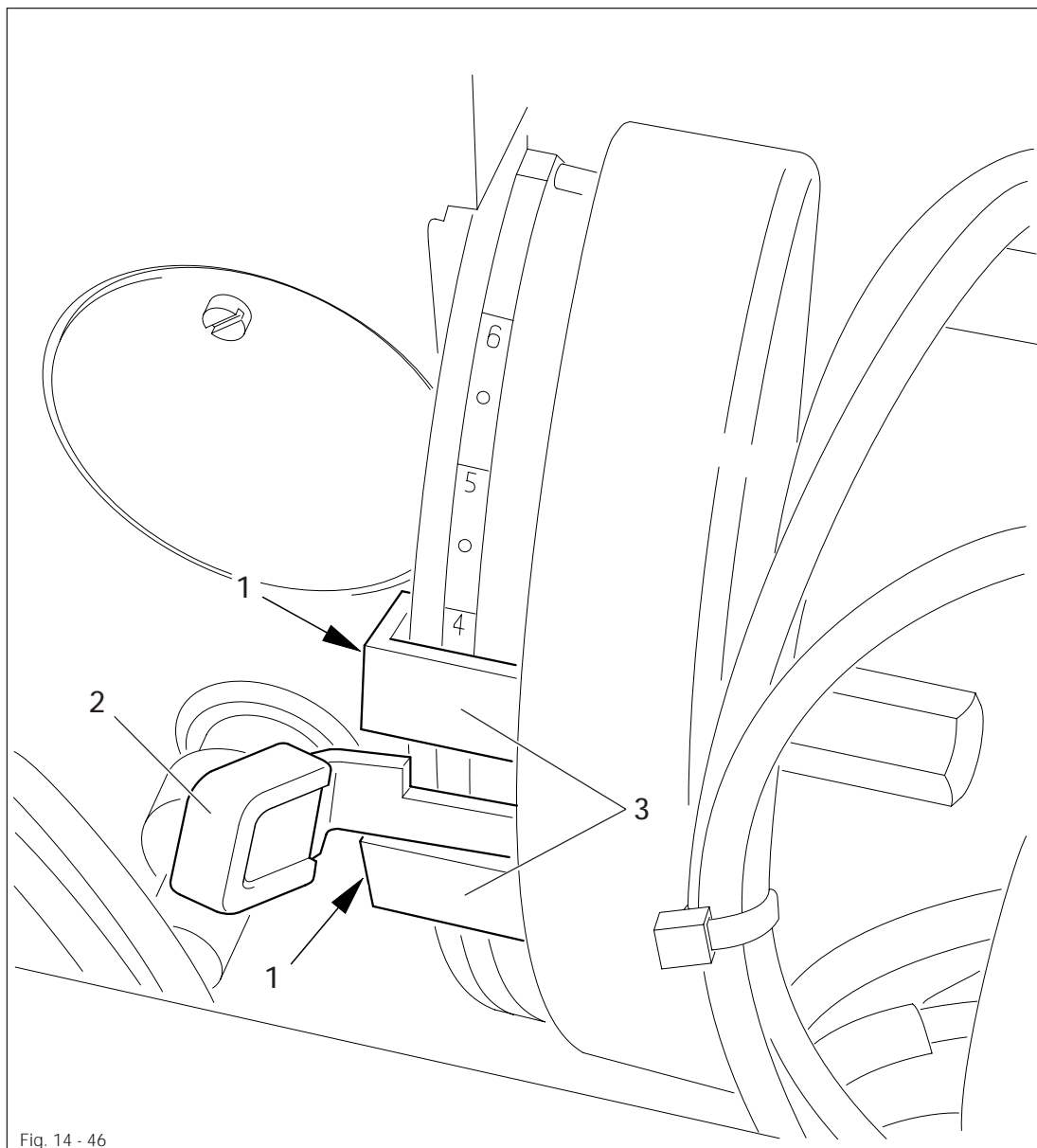

Fig. 14 - 45



- Raise the hand lever and engage the bobbin winder.
- By turning screw 1, place drive wheel 2 against friction wheel 3 in accordance with requirement 1.
- Loosen screw 5 and move stop latch 4 in accordance with requirement 2.
- Retighten screw 5.
- When winding unilaterally, turn the thread guide on the machine arm accordingly (see Chapter 11.02 Winding the bobbin thread, adjusting the primary thread tension).

14.35 Stitch length limitation



- Loosen screws 1.
- Set the desired maximum stitch length with stitch length adjustment lever 2.
- Move stops 3 in accordance with the maximum length.
- Tighten screws 1.

14.36 Stitch length adaptation

Requirement

The stitch length set at "3" must be the same length when feeding both forwards and backwards.

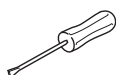
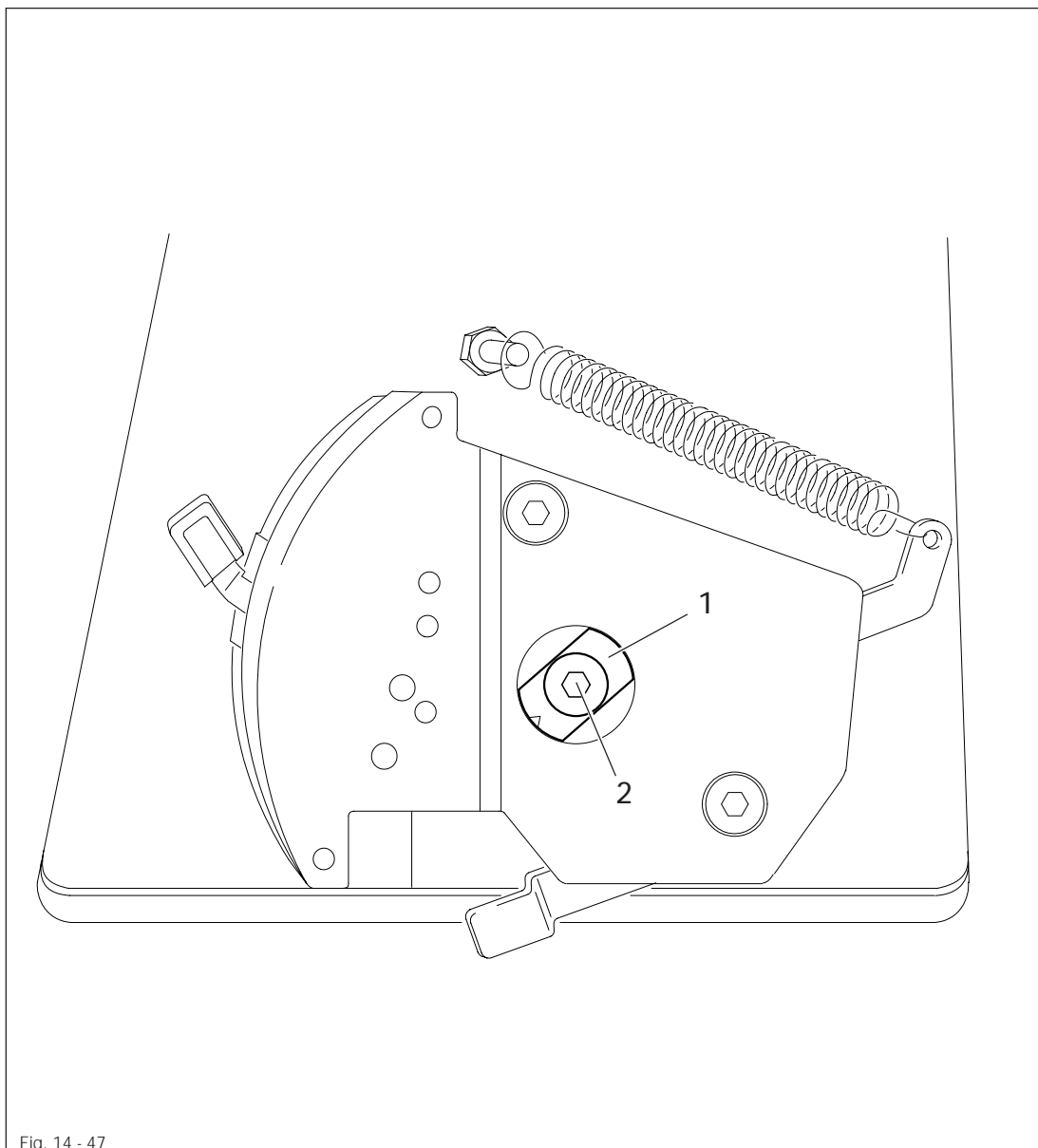

- Loosen screw 2.
- Turn bushing 1 in accordance with the **requirement**. Take care to ensure that the eccentricity of bushing 1 is facing downwards.
- Tighten screw 2.

14.37 Presser foot pressure

Requirement

The material must be fed reliably even at maximum sewing speed. There must, however, be no pressure marks left on the fabric.

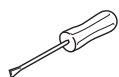
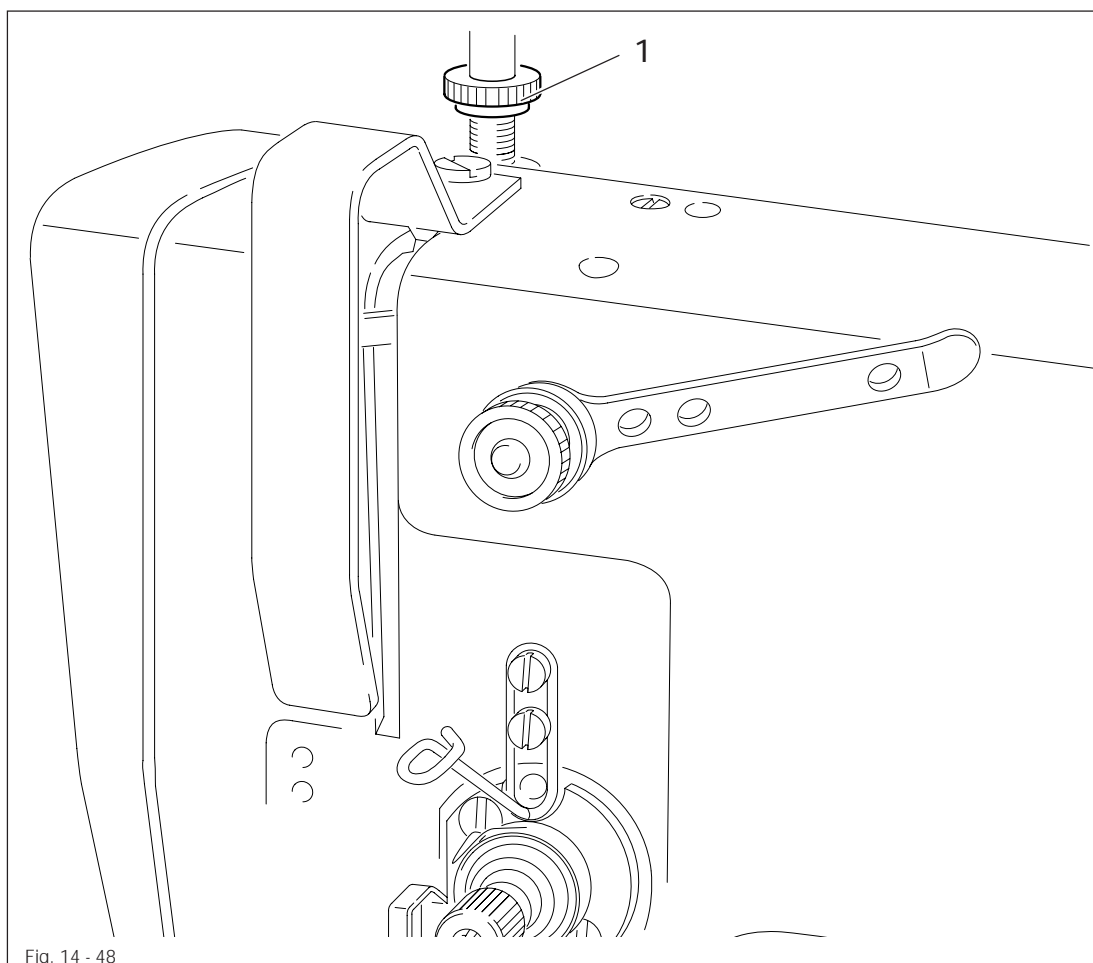

- Turn screw 1 in accordance with the requirement.

14.38 Thread trimmer

14.38.01 Pre-adjusting the control cam

Requirements

At the t.d.c of the needle bar,

1. the beginning of the highest point of the trip of the control cam **6** should be positioned under the tip of pawl **8** and
2. the right-hand side of the trip should be flush with the right-hand side of pawl **8**.

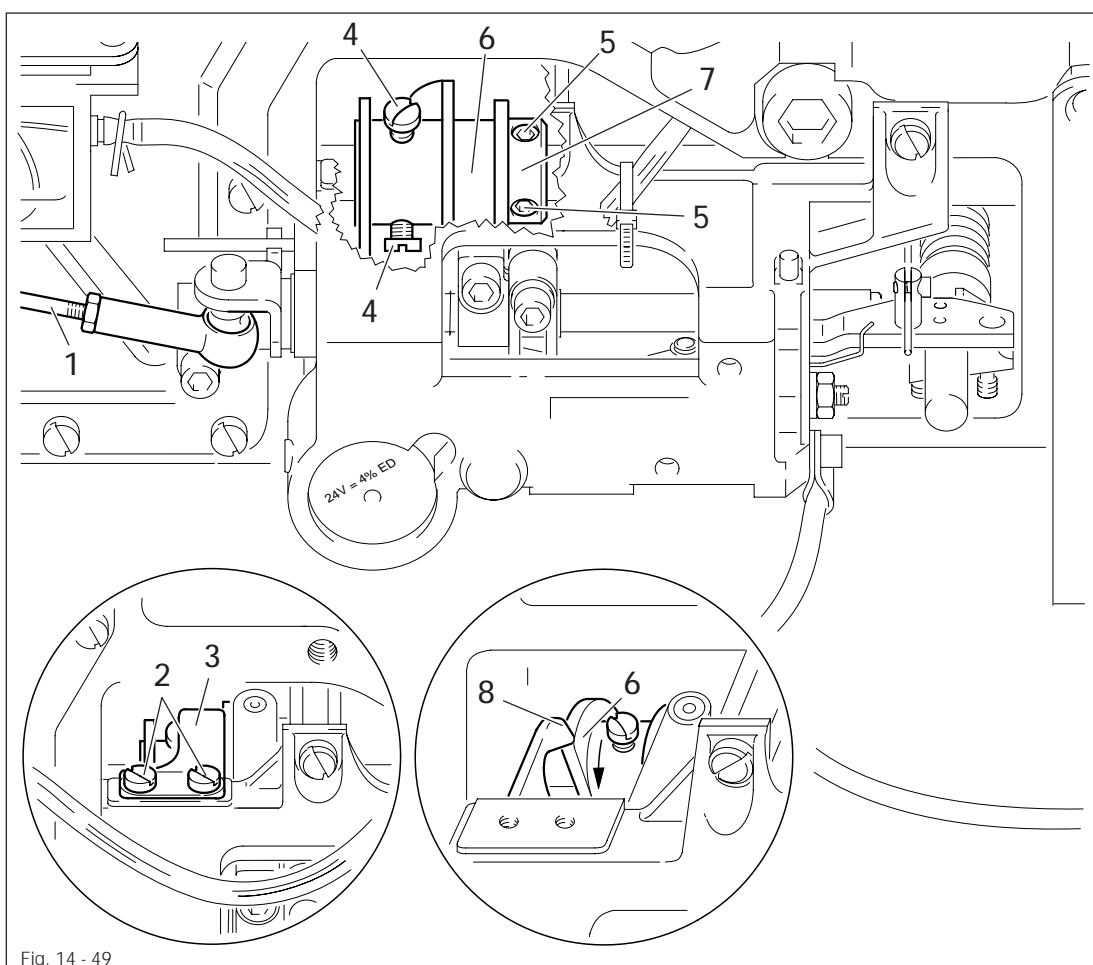
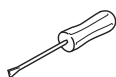

Fig. 14 - 49



- Pull the ball heads of connecting rod **1** off the ball pin at the cutting and control units and remove connecting rod **1**.
- Loosen screws **2** and retaining spring **3** together with the cover disk.
- Loosen screws **4** and **5**.
- Twist or shift control cam **6** in accordance with **requirement 1** or **requirement 2** as required.
- Tighten screws **4** firmly.
- Push fixing collar **7** onto control cam **6**.
- Tighten screws **5** firmly.



Connecting rod **1** and retaining spring **3** stay dismantled for further adjustments.

14.38.02 Roller lever

Requirements

When the needle bar is positioned 1.8 mm after the b.d.c,

1. the roller of the roller lever **4** should engage easily with the control cam **7** and
2. the roller of roller lever **4** should be centred in the cam notch of the control cam **7**

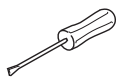
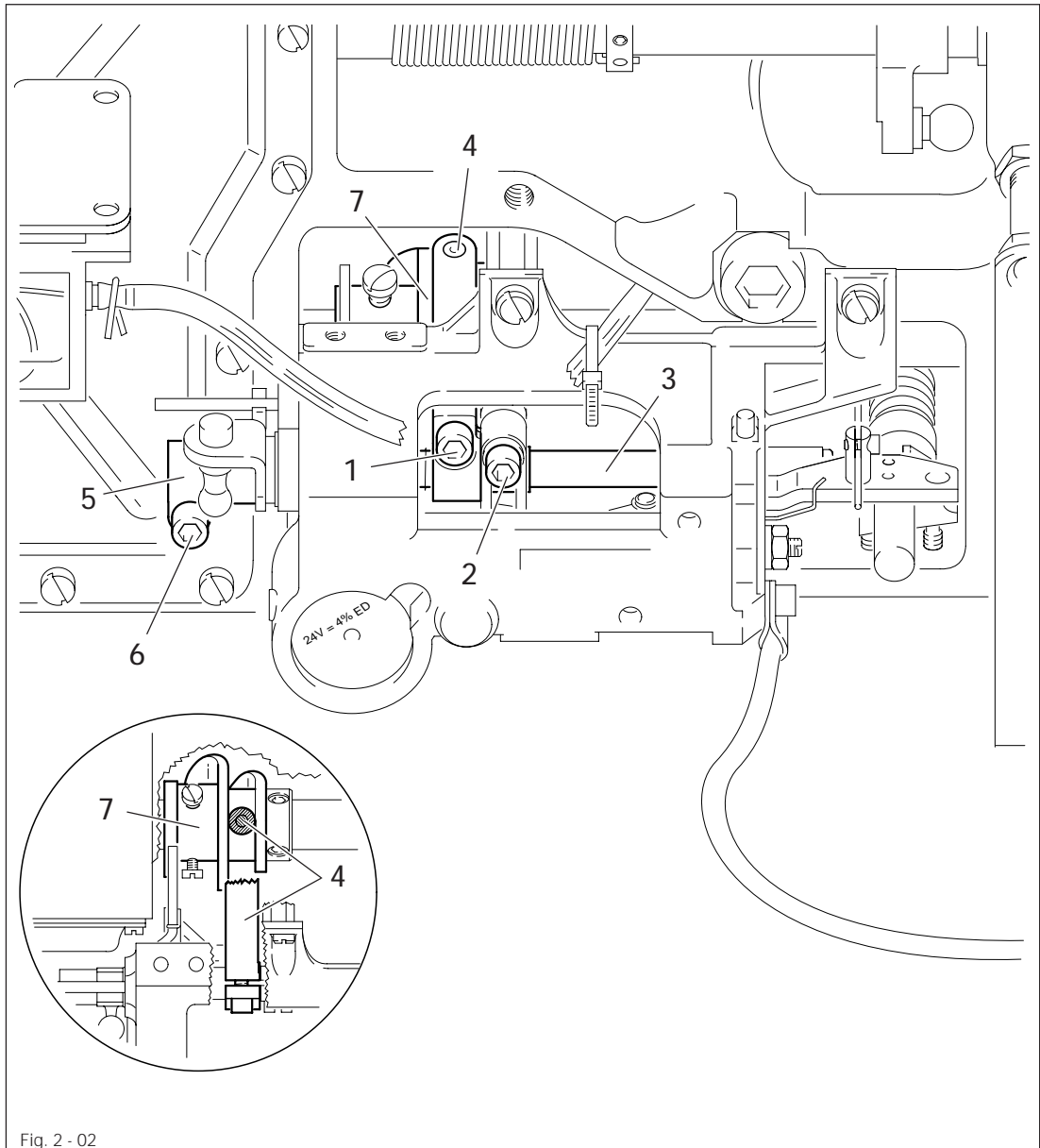

- Unscrew screws **1** and **2**.
- Put pressure on rockshaft **3** to the right.
- Adjust roller lever **4** in accordance with **requirements 1** and **2**.
- Tighten screw **1** firmly.
- Position the surface of the fixing collar **5** (bolt **6**) parallel to the base plate.



Screw **2** stays undone for the following adjustment.

14.38.03 Pawl

Requirement

With the thread trimmer in resting position, the distance between pawl 2 and the highest point of the control cam should be 0.3 mm.

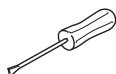
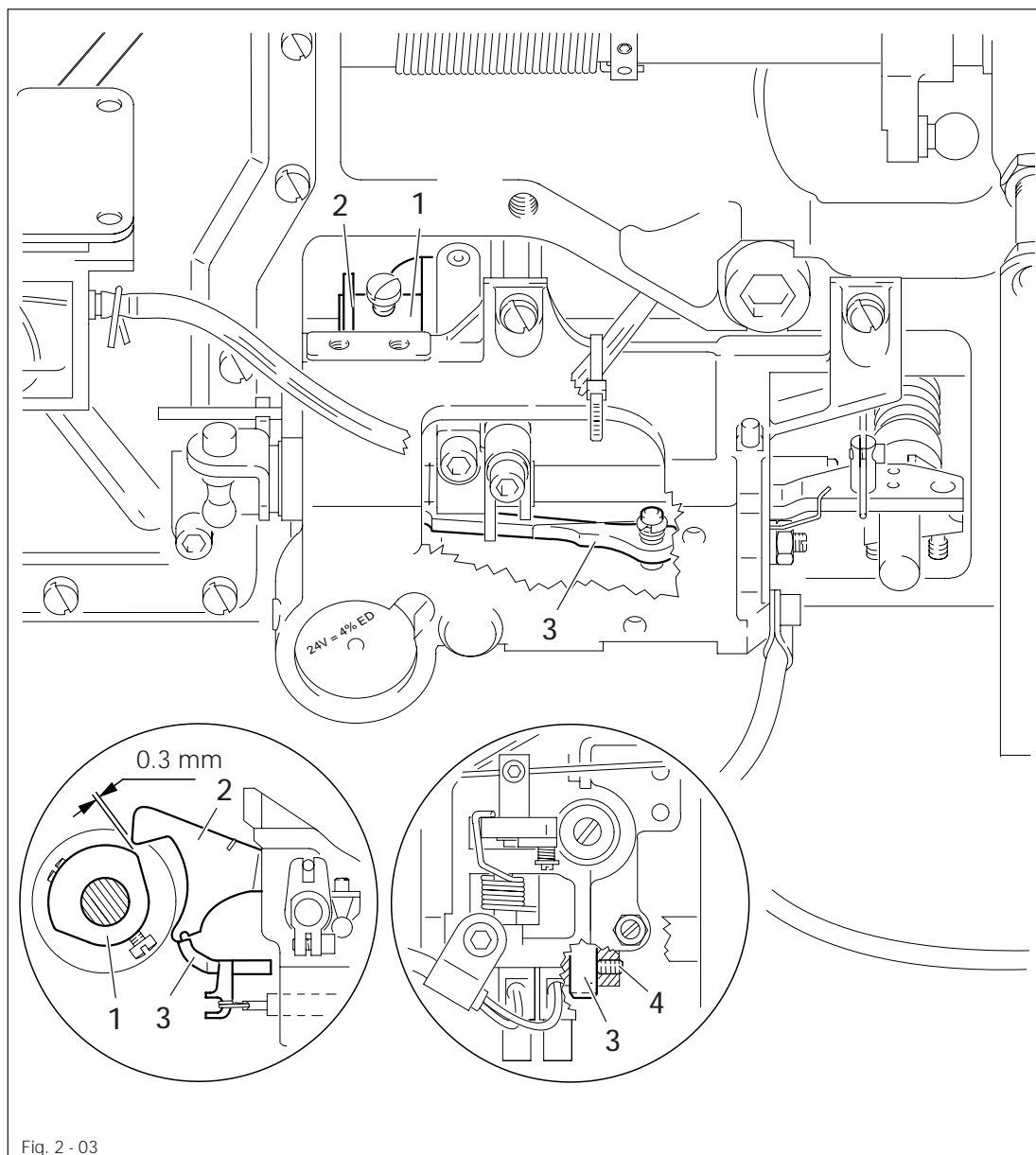

- Position the bearing surface of control cam 1 with its highest point below pawl 2 by turning the hand wheel.
- Shift pin 3 (screw 4) in accordance with the requirement.

14.38.04 Engaging solenoid

Requirement

When the needle bar is positioned 1.8 mm after the b.d.c and the engaging solenoid is actuated, the distance between the engaging lever 1 and the pawl 2 should be between 0.2 and 0.3 mm.

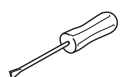
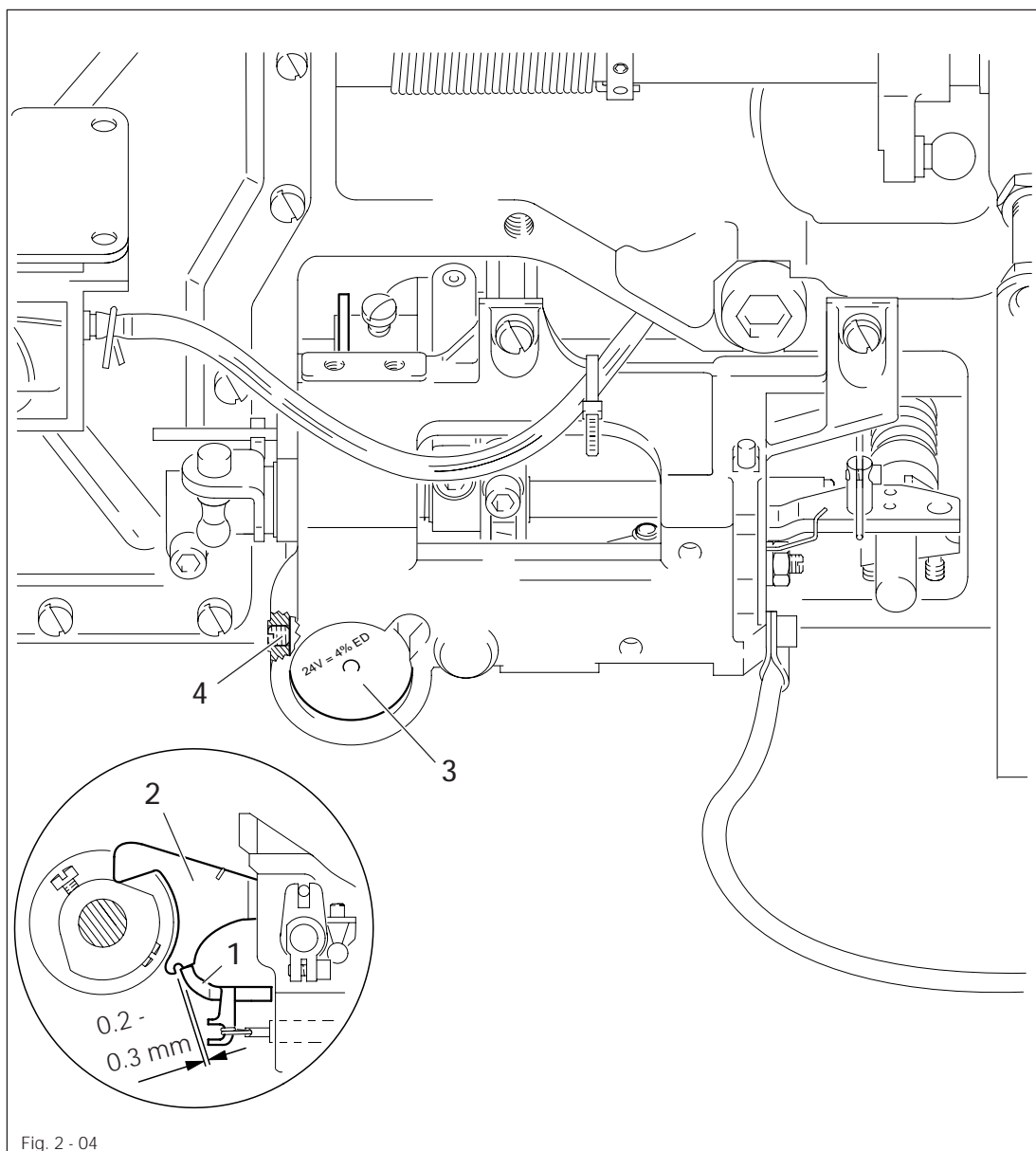

- Position the needle bar 1.8 mm after b.d.c.
- Manipulate engaging lever 1 until pawl 2 engages.
- Push magneto inductor into the magnet housing 3 as far as possible and move magnet housing 3 (screw 4) together with the magneto inductor in accordance with the requirement.

14.38.05 Release lever

Requirement

When the needle bar is positioned 1.8 mm after the b.d.c and the engaging lever **1** is actuated, the distance between the roller of the roller lever **2** and the bottom of the control cam **3** must be approx. **0.2 mm**.

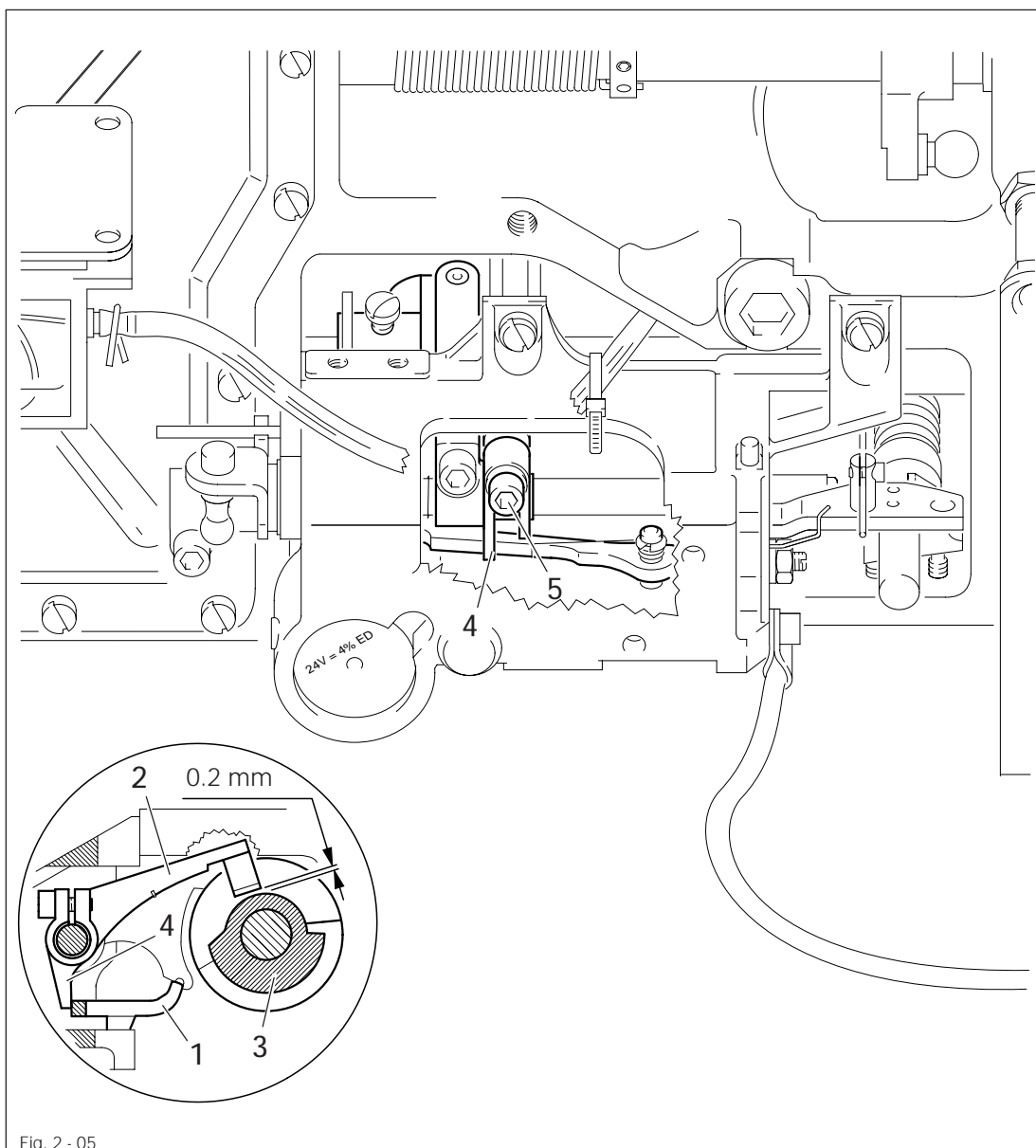
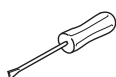

Fig. 2 - 05



- Position needle bar 1.8 mm after b.d.c
- Activate engaging lever **1** manually.
- Push roller lever **2** onto the bottom of control cam **3**.
- Tighten screw **5** slightly.
- Push release lever **4** onto engaging lever **1**.
- Adjust the distance to control cam **3** to approx. **0.2 mm** by tapping the roller lever **2** and measuring repeatedly with lever **4** which must be in constant lateral contact with roller lever **2**.
- Tighten screw **5** firmly.

14.38.06 Engaging lever

Requirement

When the needle bar is at the t.d.c and the thread trimmer is in resting position, the distance between the roller of the roller lever 3 and the outer diameter of the control cam 4 should be between 0.3 and 0.5 mm.

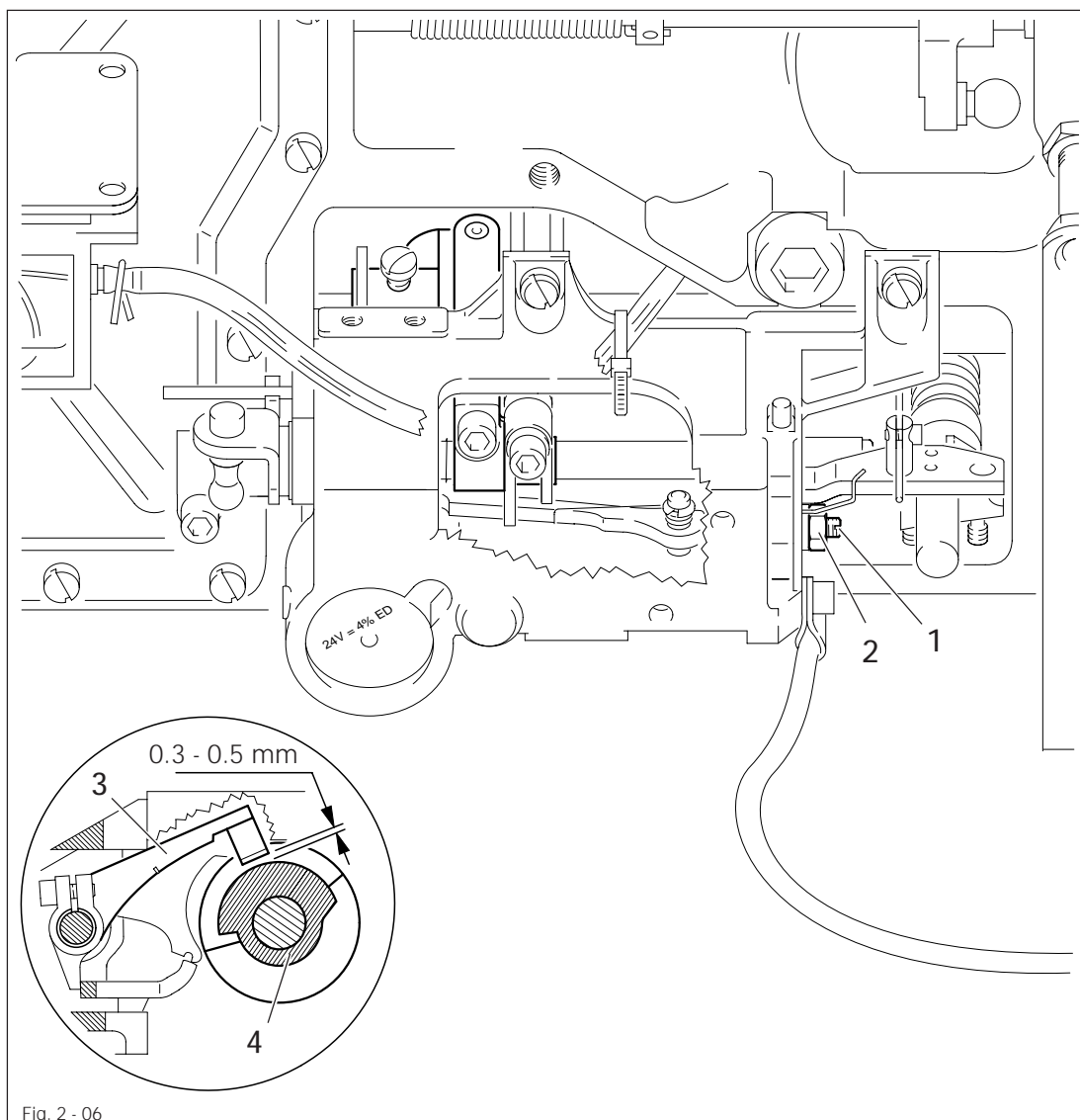
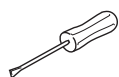

Fig. 2 - 06



- Turn screw 1 (nut 2) in accordance with the requirement.
- Check distance in accordance with the requirement.

14.38.07 Lateral adjusting of the thread catcher

Requirement

1. The tip of the thread catcher **6** should point exactly to the middle of the needle.
2. The thread catcher **6** should not touch anywhere when in motion.

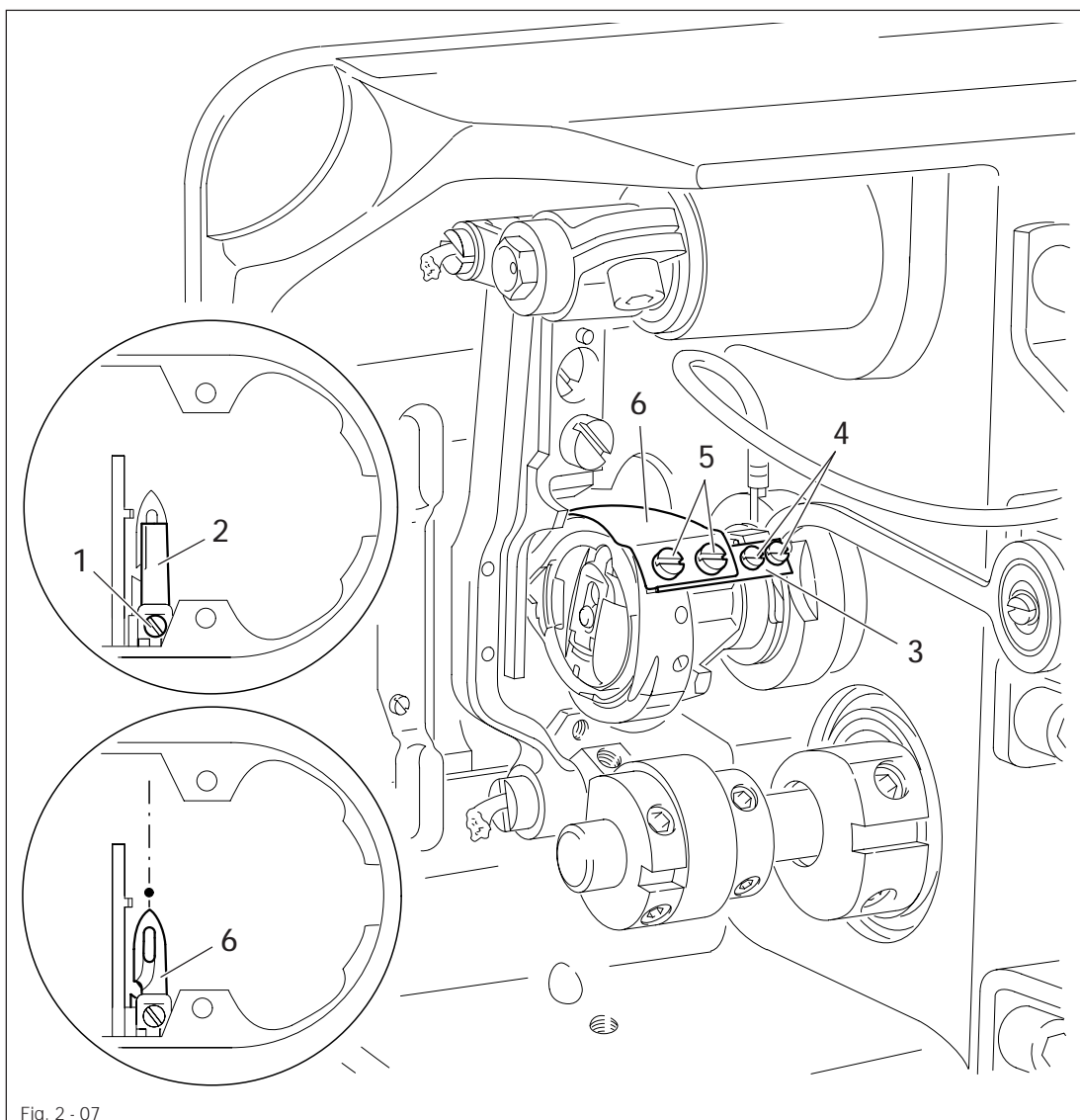
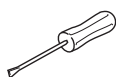

Fig. 2 - 07



- Unscrew needle plate and feed dog.
- Loosen screw **1** and remove knife **2**.
- Position needle bar at b.d.c
- Push aside catcher stop **3** (screws **4**).
- Loosen screws **5**.
- Position the tip of thread catcher **6** in front of the needle by moving the thread catcher carrier.
- Adjust thread catcher **6** laterally in accordance with **requirement 1**.
- Tighten screws **5** firmly ensuring that the back of the thread catcher is horizontal.



Needle plate, feed dog, knife **2** and catcher stop **3** stay dismantled for the following adjustments.

14.38.08 Front reversal point of the thread catcher

Requirement

In the front reversal point of the thread catcher **3** the rear edge of thread catcher cutout should be **1 mm** in front of the bobbin case position finger **4**.

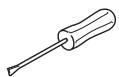
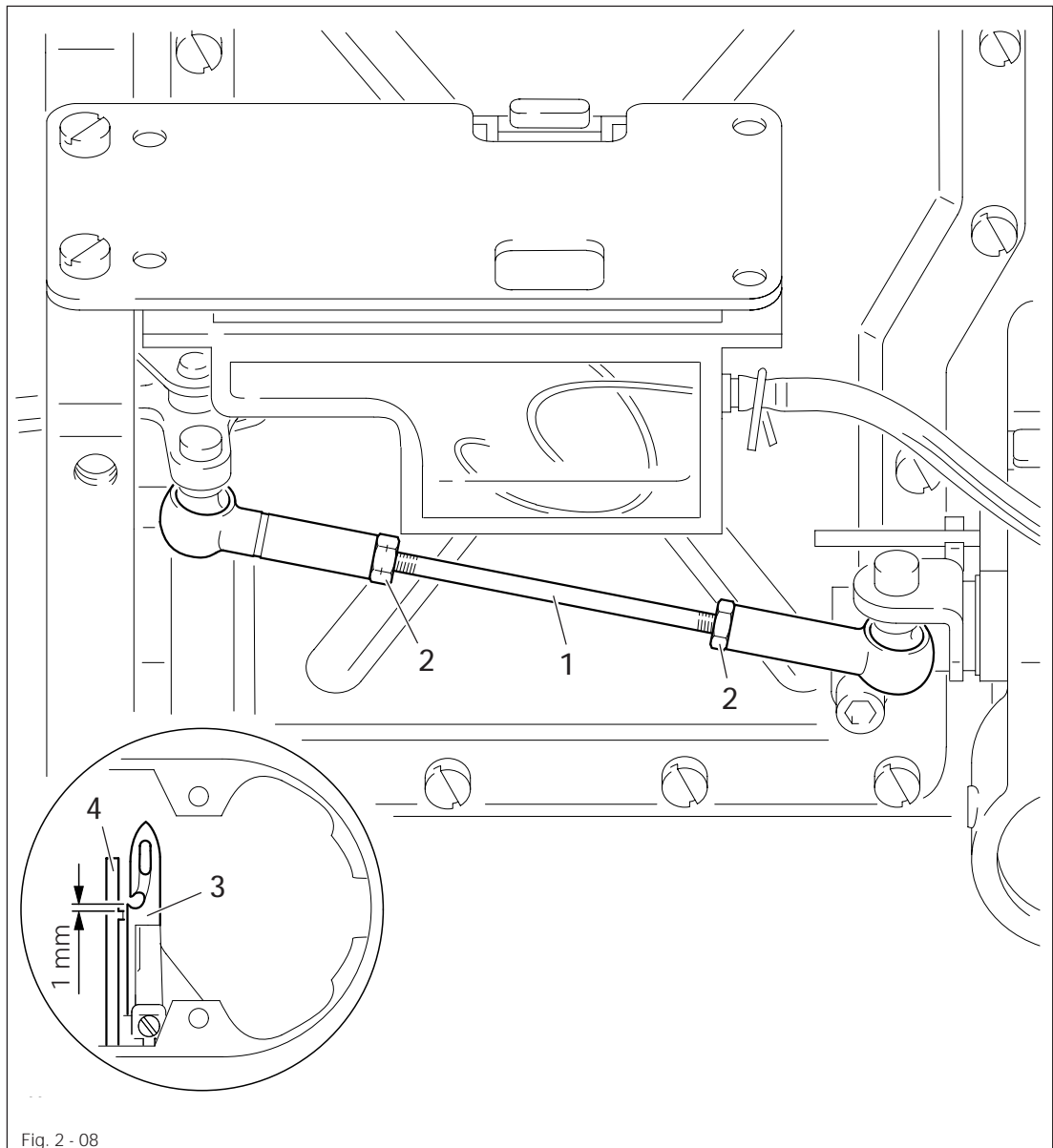

- Push balls of the connecting rod **1** onto the ball pins on the cutting and control units.
- Loosen nuts **2** (right-hand and left-hand thread).
- Position needle bar at t.d.c
- Activate the engaging lever manually.
- Bring thread catcher **3** to its front point of reversal by turning the hand wheel.
- Turn connecting rod **1** in accordance with the **requirement**.
- Lock connecting rod **1** by means of nuts **2**.

14.38.09 Re-adjusting the control cam

Requirement

When the end of the hook plate 1 is positioned 2 mm behind the middle of the lug of the bobbin case position finger, the distance between the tip of the thread catcher 6 and the middle of the lug should also be 2 mm.

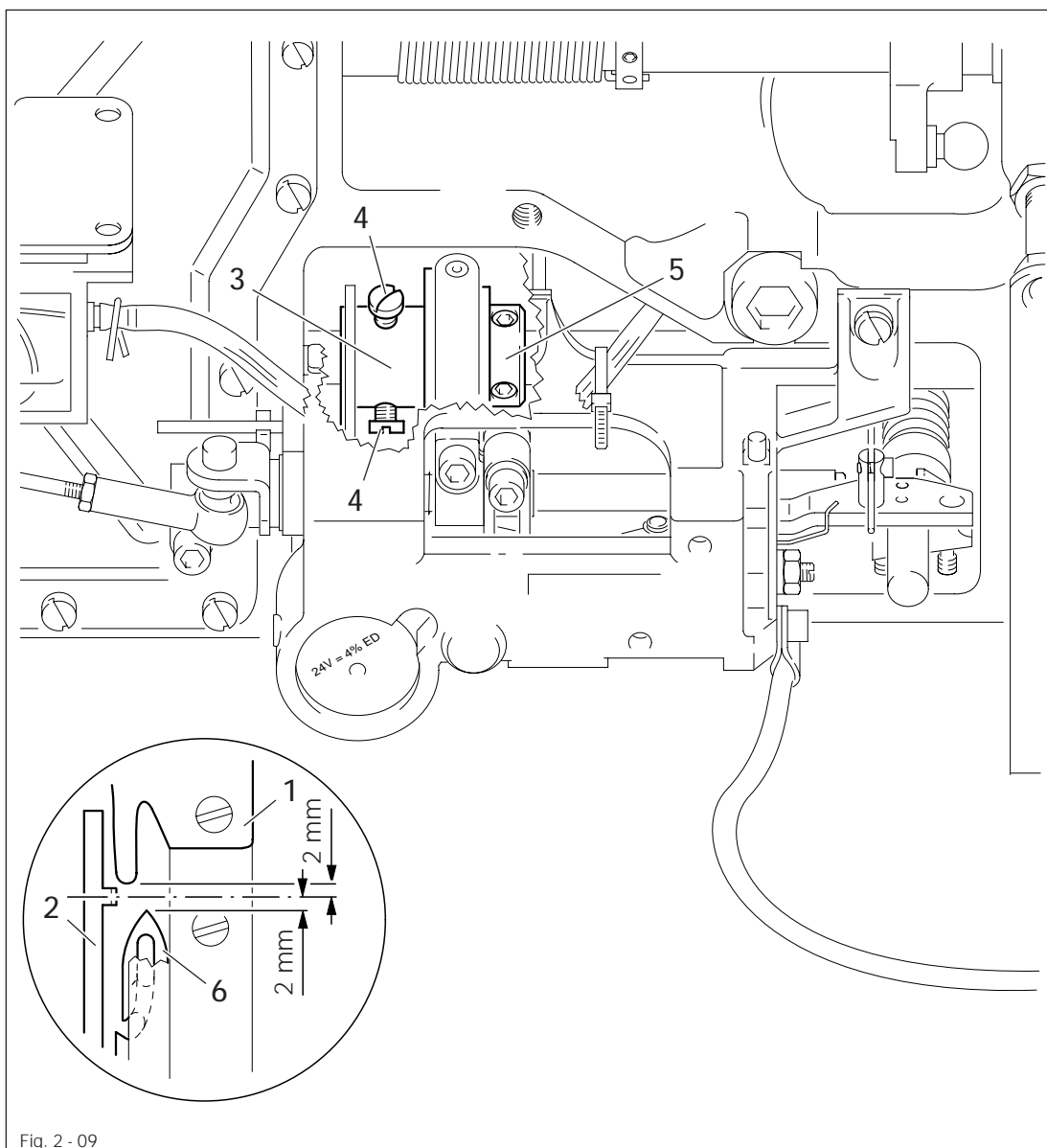
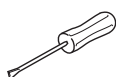

Fig. 2 - 09



- Position the needle bar at b.d.c
- Activate the engaging lever manually.
- Turn the hand wheel until the distance between the end of hook plate 1 and the middle of the lug of the bobbin case position finger 2 is 2 mm.
- Turn control cam 3 (screws 4) in accordance with the **requirement** and bring it into contact with fixing collar 5.

14.38.10 Retaining spring

Requirement

When the thread trimmer is in resting position, the distance between the retaining spring **1** and the roller lever **3** should be **0.5 mm**.

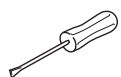
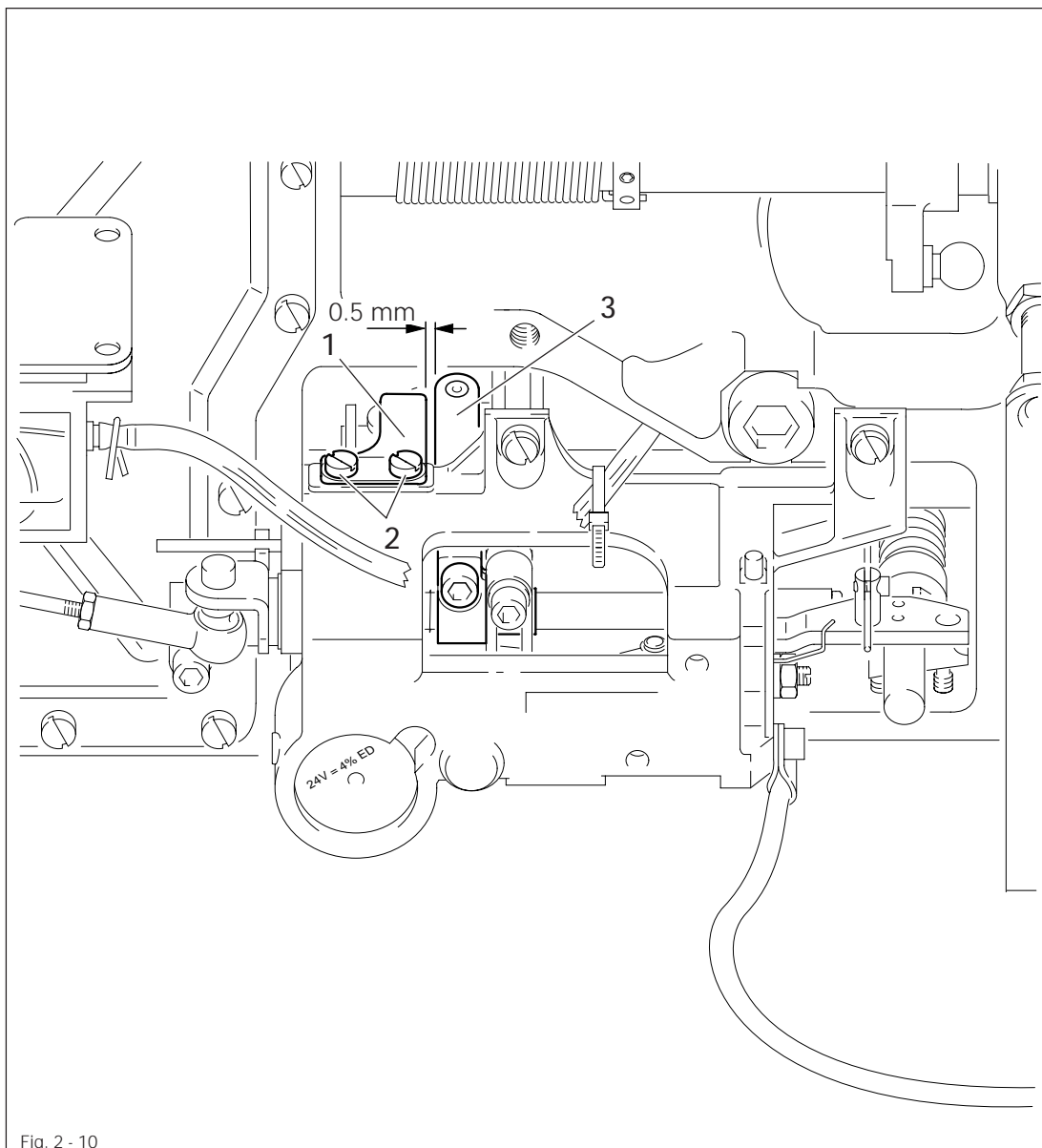

- Position retaining spring **1** together with the cover disk.
- Tighten screws **2** slightly.
- Push retaining screw **1** up to the stop and adjust in accordance with the **requirement**.
- Tighten screws **2** firmly.

14.38.11 Knife to needle clearance

Requirement

The distance between the front edge of the knife **1** and the needle should be **4 mm**.

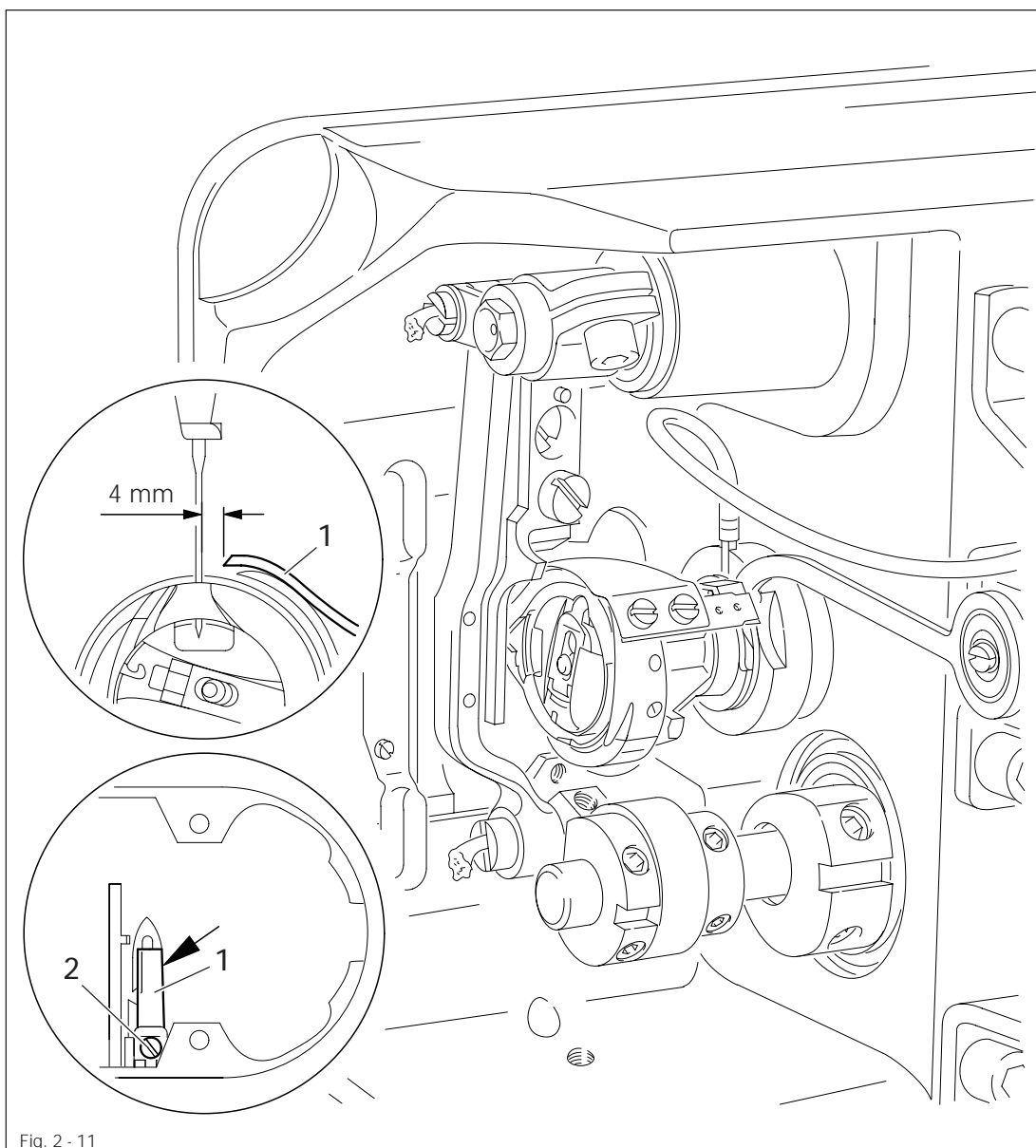
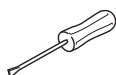

Fig. 2 - 11



- On needle-feed machines set the stitch length to "0".
- Position the needle bar at b.d.c
- Push knife **1** under the safety plate and align in accordance with the **requirement**.
- Tighten screw **2** slightly.
- Activate the engaging lever manually.
- Turn the hand wheel until the cutting point in the thread catcher is positioned immediately in front of the knife blade.
- Adjust knife **1** so that the right edge of the knife does not protrude over the right edge of the thread catcher (see arrow).
- Tighten screw **2** firmly.

14.38.12 Manual trimming control

Requirement

Both threads have to be cut perfectly in the catcher cutout on both right and left-hand side.

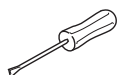
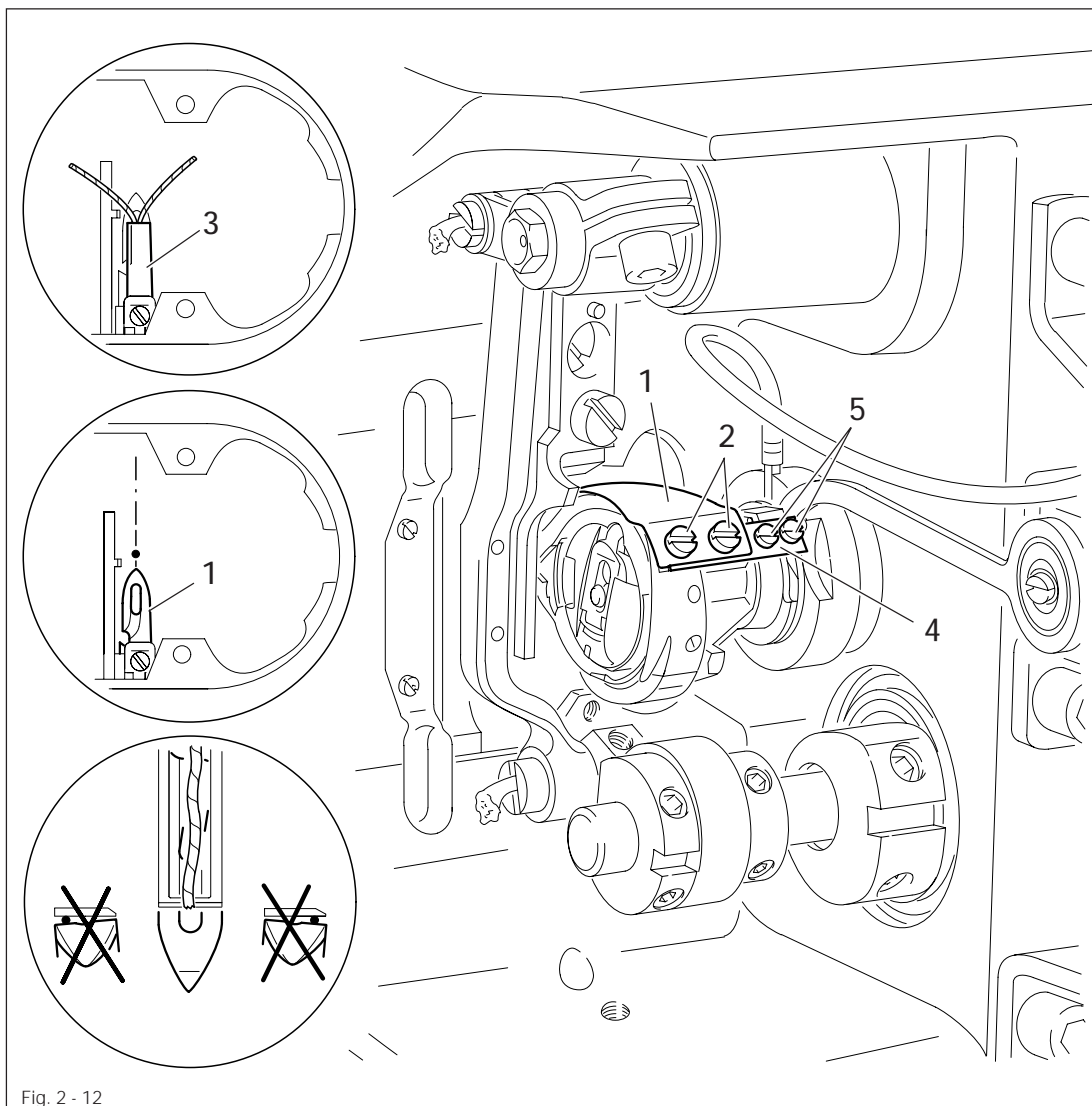

- Position the needle bar at b.d.c and activate the engaging lever manually.
- Turn the hand wheel until thread catcher 1 is its front reversal point.
- Double a thread and insert it into the cutout of thread catcher 1.
- Turn the hand wheel further until the trimming process is finished.
- If both threads are not trimmed in accordance with the **requirement**, loosen screws 2 and align thread catcher 1 with respect to knife 3 .
- Make sure that the tip of the thread catcher is pointing to the centre of the needle and tighten screws 2 firmly.
- Move catcher stop 4 onto thread catcher 1 and tighten screws 5 firmly.
- Screw on feed dog and needle plate, making sure that the movement of the feed dog in the needle plate cutout is not restricted.

14.38.13 Tension release of needle thread

Requirements

1. When the thread trimming unit is in resting position, trip 5 should be engaged and at a distance of **0.5 mm** from the release cone 1.
2. When trip 5 is positioned at the highest point of the release cone 1, the tension disks should be spaced at a minimum of **0.5 mm** from each other.

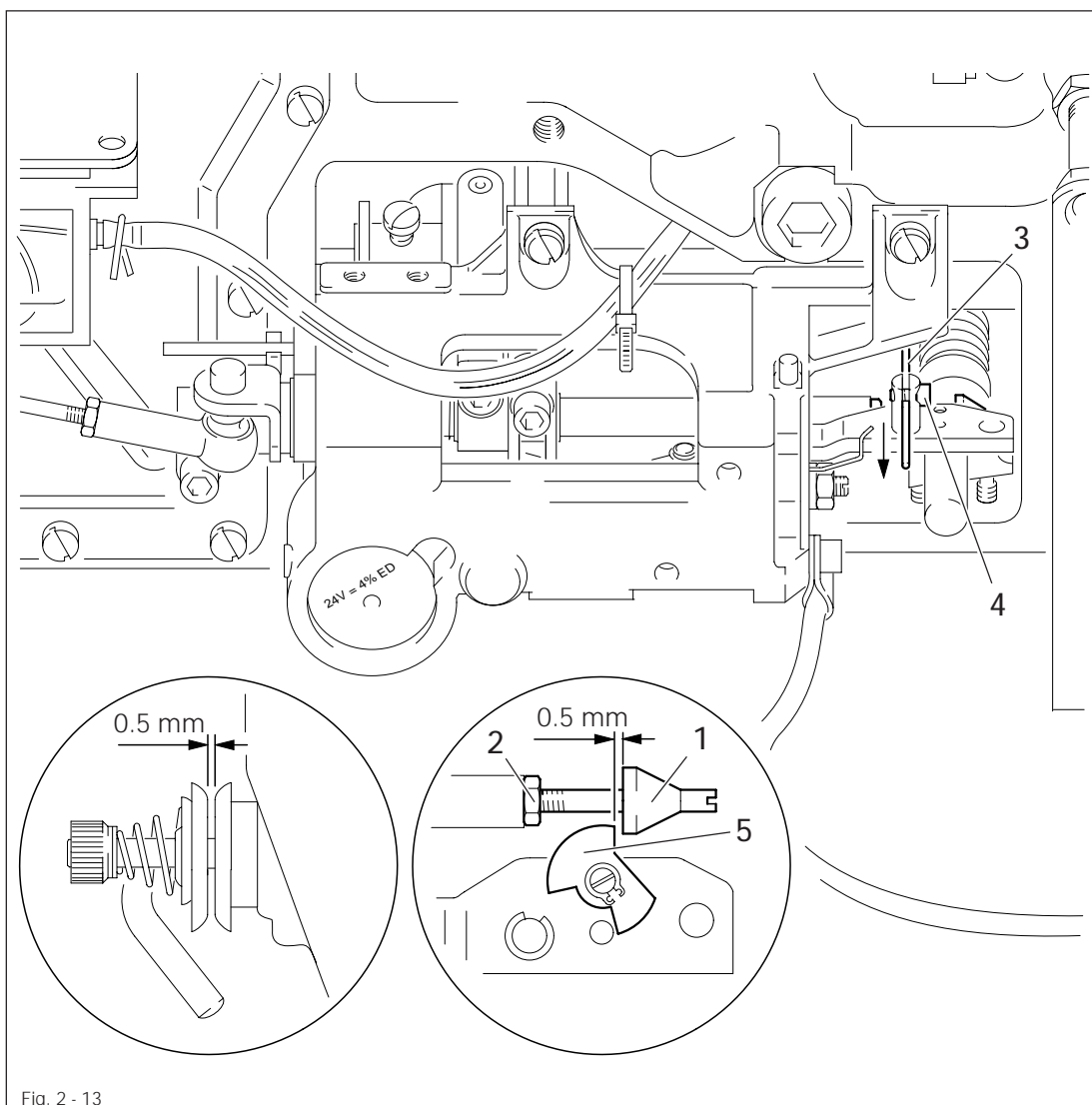
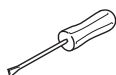

Fig. 2 - 13



- Turn release cone 1 (nut 2) in accordance with **requirement 1**.
- Lower the presser foot onto the needle plate.
- Pull out the thread from between the tension disks.
- Pull down linkage 3 (screw 4) until you feel it stop.
- Position the needle bar at b.d.c and activate the engaging lever manually.
- Turn the hand wheel until trip 5 is positioned at the highest point of release cone 1.
- The tension disks now have to be spaced at a minimum of **0.5 mm** from each other.
- Bring the rock shaft back to its starting position by turning the hand wheel.
- Trip 5 now must be engaged, the needle thread must be under full tension.
- Grease release cone 1 slightly.

14.38.14 Positioner

Requirements

1. When sewing is interrupted, the machine should position itself **4 to 5 mm** after the b.d.c of the needle bar.
2. After trimming, the machine should position itself at the t.d.c of the take-up lever.

- Adjustments to be carried out in accordance with the instruction manual of the motor.

14.38.15 Mounting and dismantling the control unit

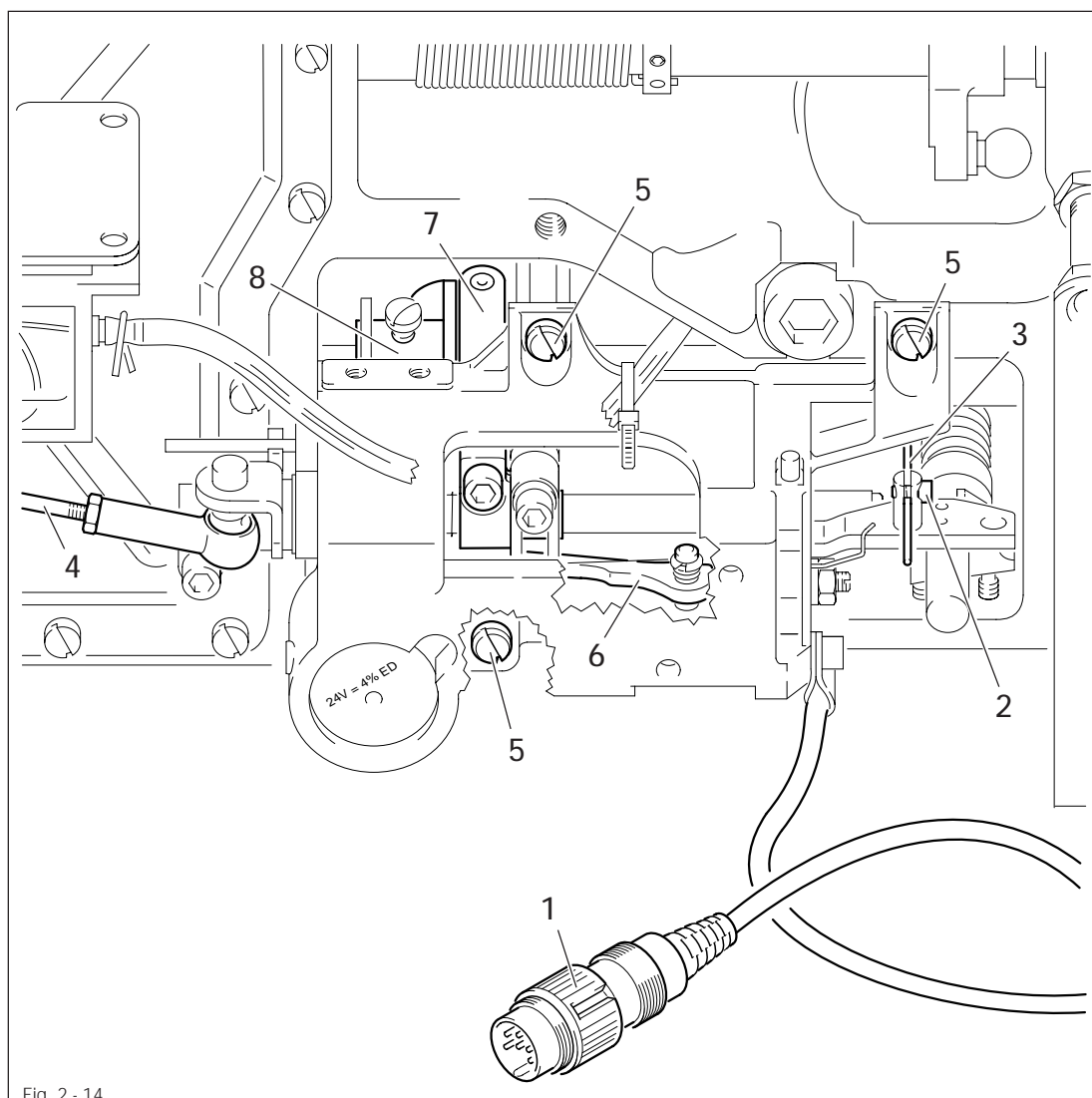
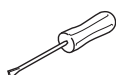

Fig. 2 - 14



- In order to dismantle the control unit, pull plug 1 out of the socket of the motor control plate or the control box as applicable.
 - Loosen screw 2 and remove linkage 3 from its slot.
 - Remove connecting rod 4.
 - Loosen screws 5 and take off complete control unit.
-
- In order to mount the control unit, position the needle bar at t.d.c.
 - Put the control unit back on and tighten screws 5 slightly.
 - Activate engaging lever 6 manually, so that roller lever 7 engages with control cam 8.
 - Align the control unit, so that the roller of roller lever 7 is centred in the cam notch 8.
 - Tighten screws 5 firmly.
 - Replace connecting rod 4 and linkage 3 and tighten screws 2 firmly.
 - Plug in plug 1.
 - Check performance manually.
 - If engaging lever 6 is not released, repeat adjustment of control unit.

PFAFF

**G.M. PFAFF
Aktiengesellschaft**

Postfach 3020
D-67653 Kaiserslautern

Königstr. 154
D-67655 Kaiserslautern

Telefon: (0631) 200-0
Telefax: (0631) 172 02
Telex: 45753 PFAFF D

Gedruckt in der BRD
Printed in Germany
Imprimé en R.F.A.
Impreso en la R.F.A.
Stampato in R.F.G.
отпечатано ФРГ