

PFAFF

3557

Instruction book

-3/01

-3/11

-3/02

-3/12

For programming the Sensewmat-control use the instruction and service manual "SENSEWMAT I".

Notes on safety

- The machine must only be commissioned in full knowledge of the instruction book and operated by persons with appropriate training.
- The machine must only be used for the purpose intended.
- Use of the machine without the safety devices belonging to it is not permitted.
- When gauge part are exchanged (e.g. needle, presser foot, needle plate, feed dog and bobbin) during threading, when the workplace is left, and during service work, the machine must be isolated from the mains by switching off the main switch or disconnecting the mains plug.
On mechanically operated clutch motors without start inhibitor it is necessary to wait until the motor has stopped.
- General servicing work must only be carried out by appropriately trained persons.
- Repairs, conversion and special maintenance work must only be carried out by technicians or persons with appropriate training.
- For service or repair work on pneumatic systems the machine must be isolated from the compressed air supply system.
Exceptions to this are only adjustments and function checks made by appropriately trained technicians.
- Work on the electrical equipment must only be carried out by electrical engineers or appropriately trained persons.
- Work on parts and systems under electric current is not permitted, except as specified in regulations DIN 57105 or VDE 0105.
- Conversions or changes to the machine must be authorized by us and only be made on adherence to all safety regulations.
- For repairs, only replacement parts approved by us must be used.



This symbol draws attention to special danger of injury.

It is imperative to read and adhere to these notes and all generally applicable safety regulations.

CONTENTS

For notes on safe machine operation see inside front cover

Control elements

- 1 Switching on the machine
- 2 Inserting the needle
- 3 Bobbin winding
- 4 Thread tension regulating for bobbin winding
- 5 Removing the bobbin case
- 6 Threading the bobbin
- 7 Regulating the bobbin thread tension
- 8 Inserting the bobbin case
- 9 Threading the needle
- 10 Regulating the needle thread tension
- 11 Adjusting the stitch length
- 12 Top feed stroke
- 13 Presser foot height
- 14 Workpiece retainer
- 15 Seam depth
- 16 Program selection
- 17 Inserting the workpiece
- 18 Sewing
- 19 Exchanging turning plate at the turning head
- 20 Stacker (only for subcl. -3/11 and -3/12)
- 21 Disturbances
- 22 Re-sewing in case of thread breakage or bobbin change
- 23 Air jet selection (only on subcl. -3/02 and -3/12)
- 24 Switching off the machine
- 25 Care and maintenance

CONTROL ELEMENTS

master switch

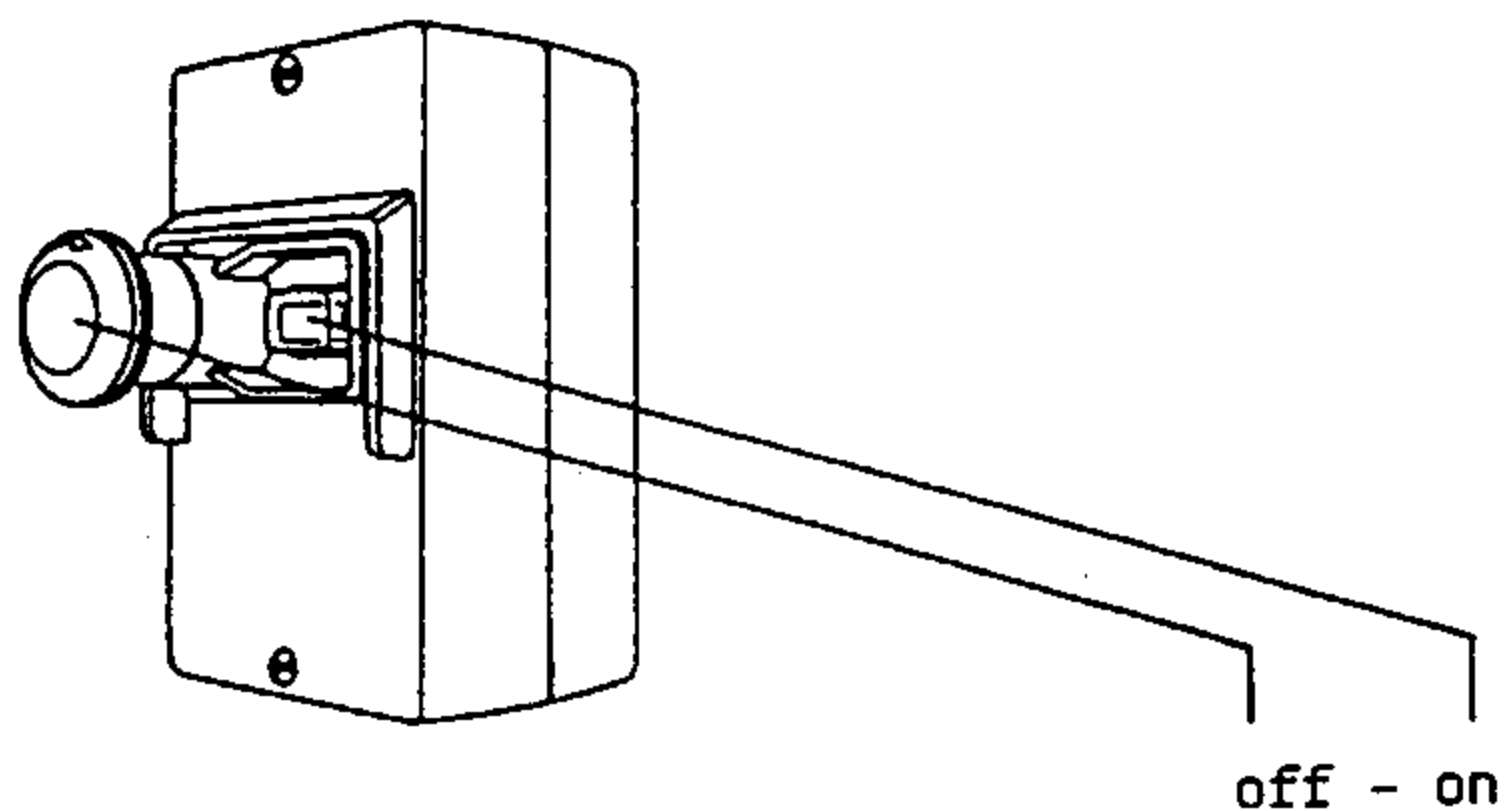

pedal

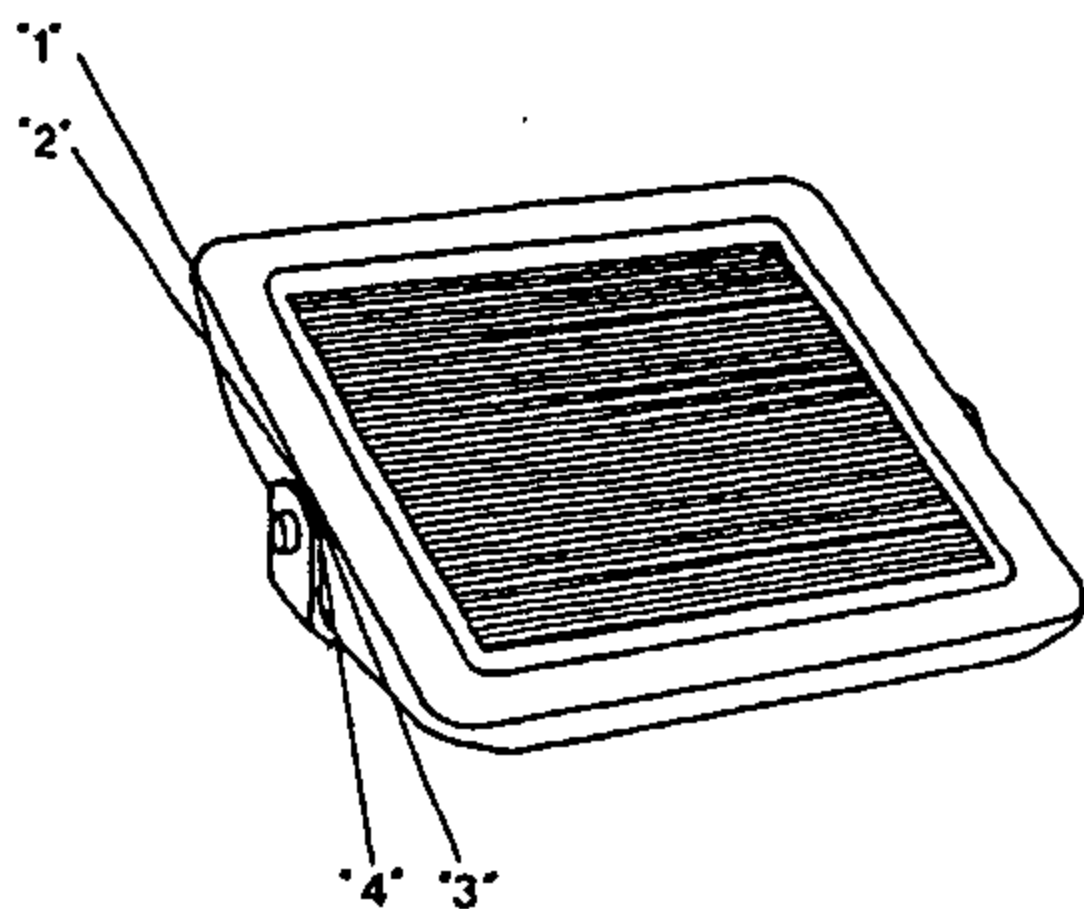

program start

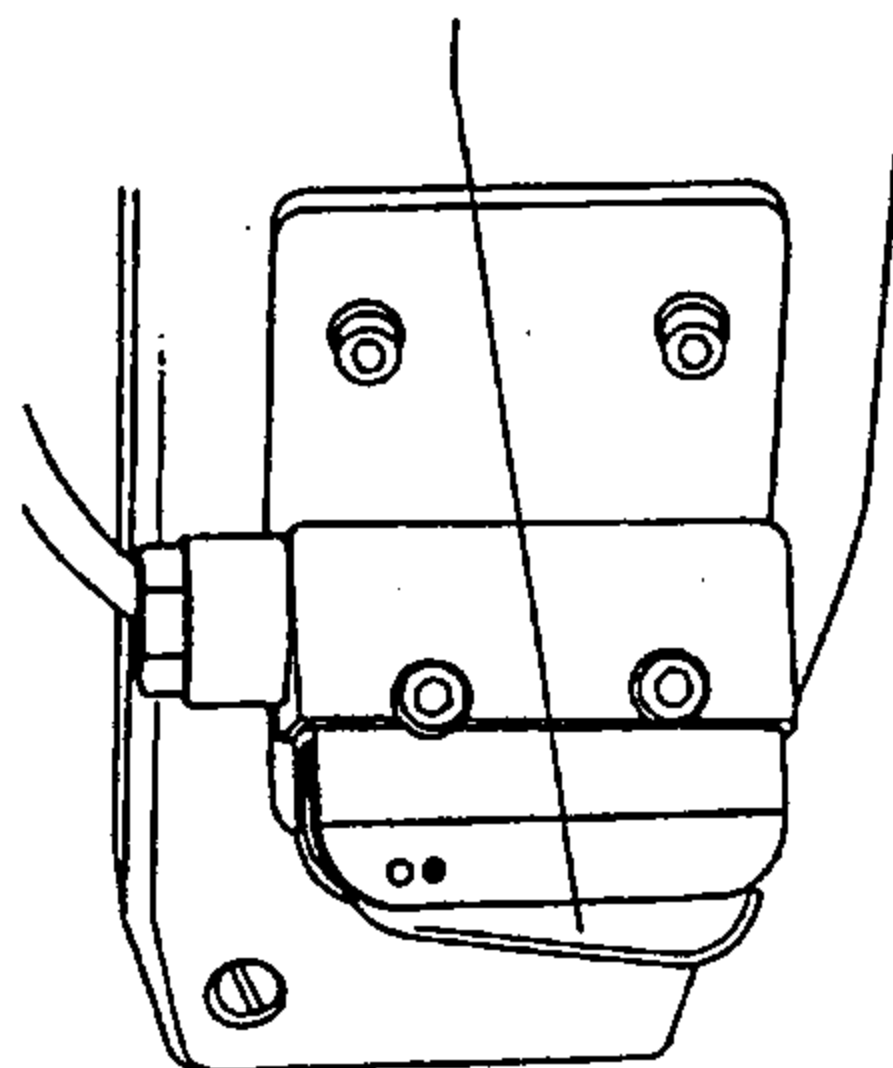

"1" - rest position

"2" - sewing
- without program at Sensemat switch position "Manual"
- with the Sensemat program selected at Sensemat switch position "Auto"

"3" - presser foot up

"4" - presser foot up, thread trimming



one -piece collar



diagonal cuffs



shoulder straps

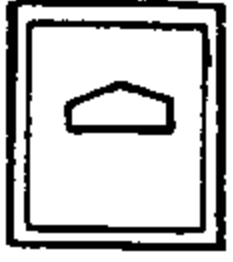

pocket flaps

no program

key pressed - two piece collar



automatic control on



reset



re-sewing after thread breakage



seam depth 1 or 2 (as required)



workpiece retainer down,
key depressed - at all seams
key not depressed - only at
long seams



loading guide up
(for working w/o loading guide)

thread monitor

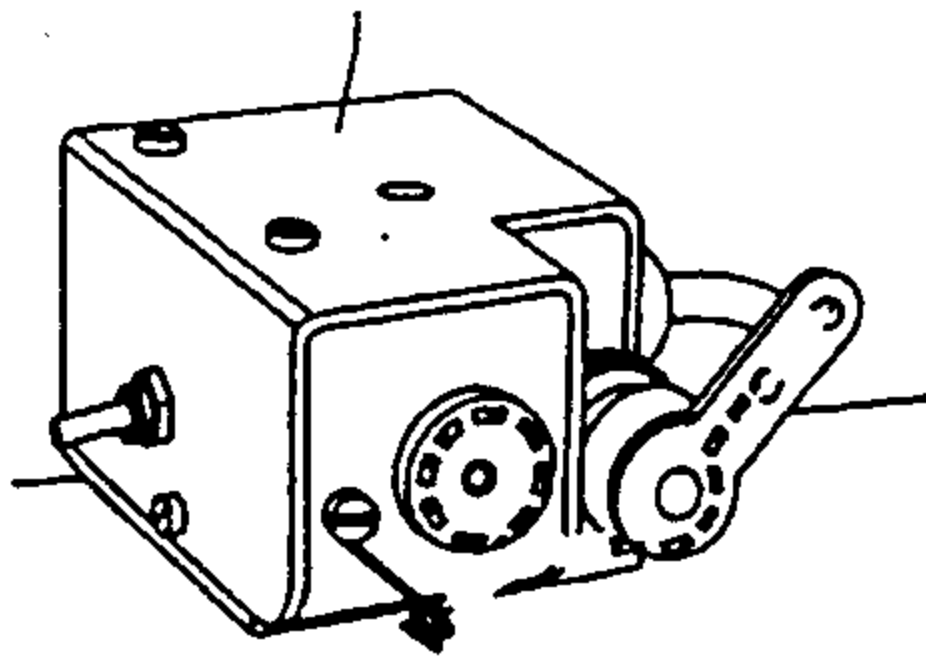

piece counter

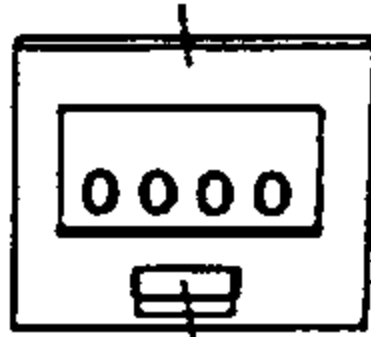

reset button

For explanation of control panel, see instruction- and service manual for Sensemat 1

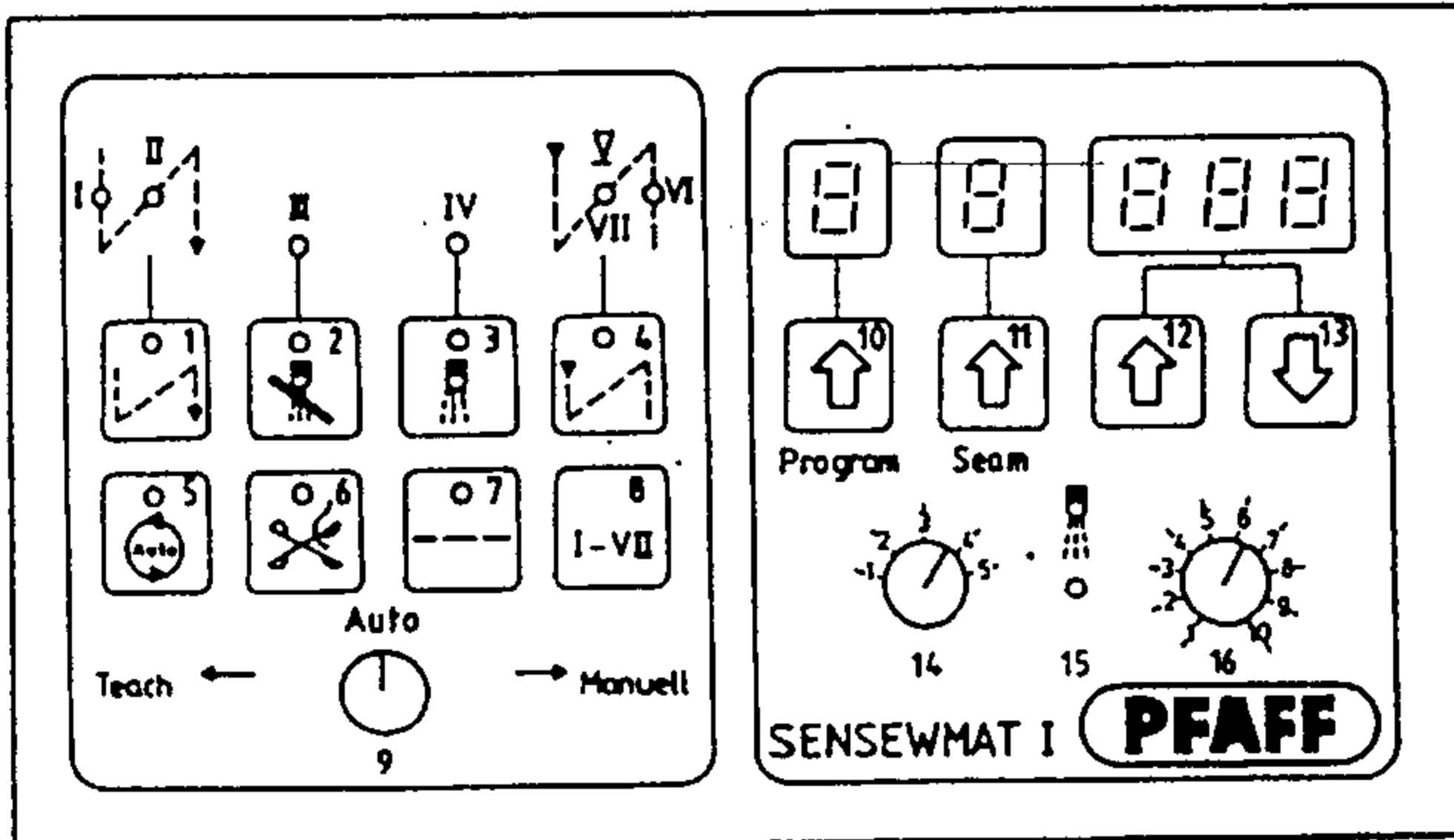

program keys

function keys

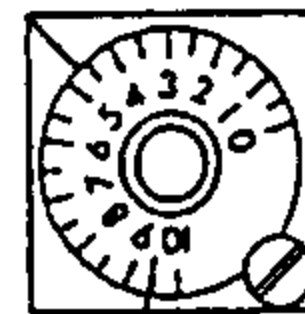
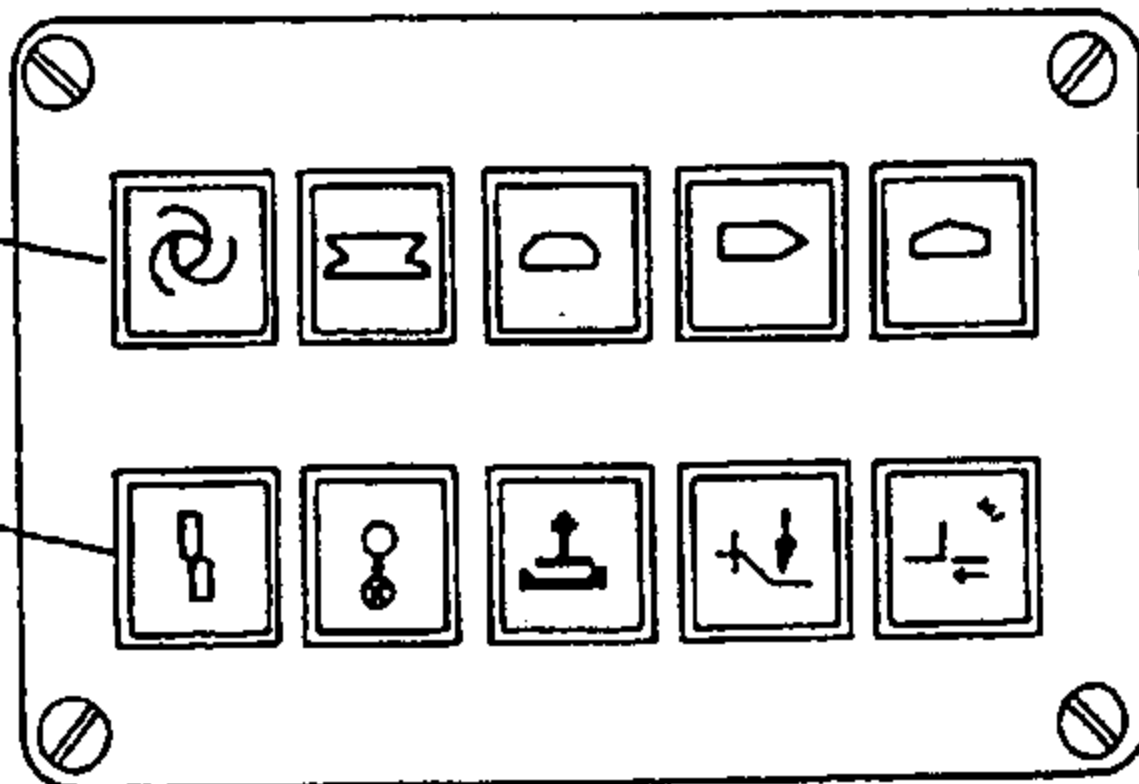

potentiometer for position "turning head center"

1 Switching ont the machine

Open pressure valve of main air supply.

Check that gauge 1 (Fig. 1) shows a pressure of 6 bar.

If necessary, have this pressure set by the mechanic.

Turn knurled ring 2 (Fig. 2) in direction of arrow,
- stop button disengages.

Press button 3
- machine switched on.

Set toggle switch 4 (Fig. 3) to front,
- thread monitor switched on.

Press key 5 (Fig. 4),
- program control switched on.*

2 Inserting the needle

| Use system 134KK needles only.

Switch off machine.

Push needle up in needle bar as far as it will go, turn it so that the clearance cut faces the sewing hook and tighten screw 6 (Fig. 5).

* The program control can only be switched on when the photocell is not blocked, i.e. when there is no workpiece under the photocell.

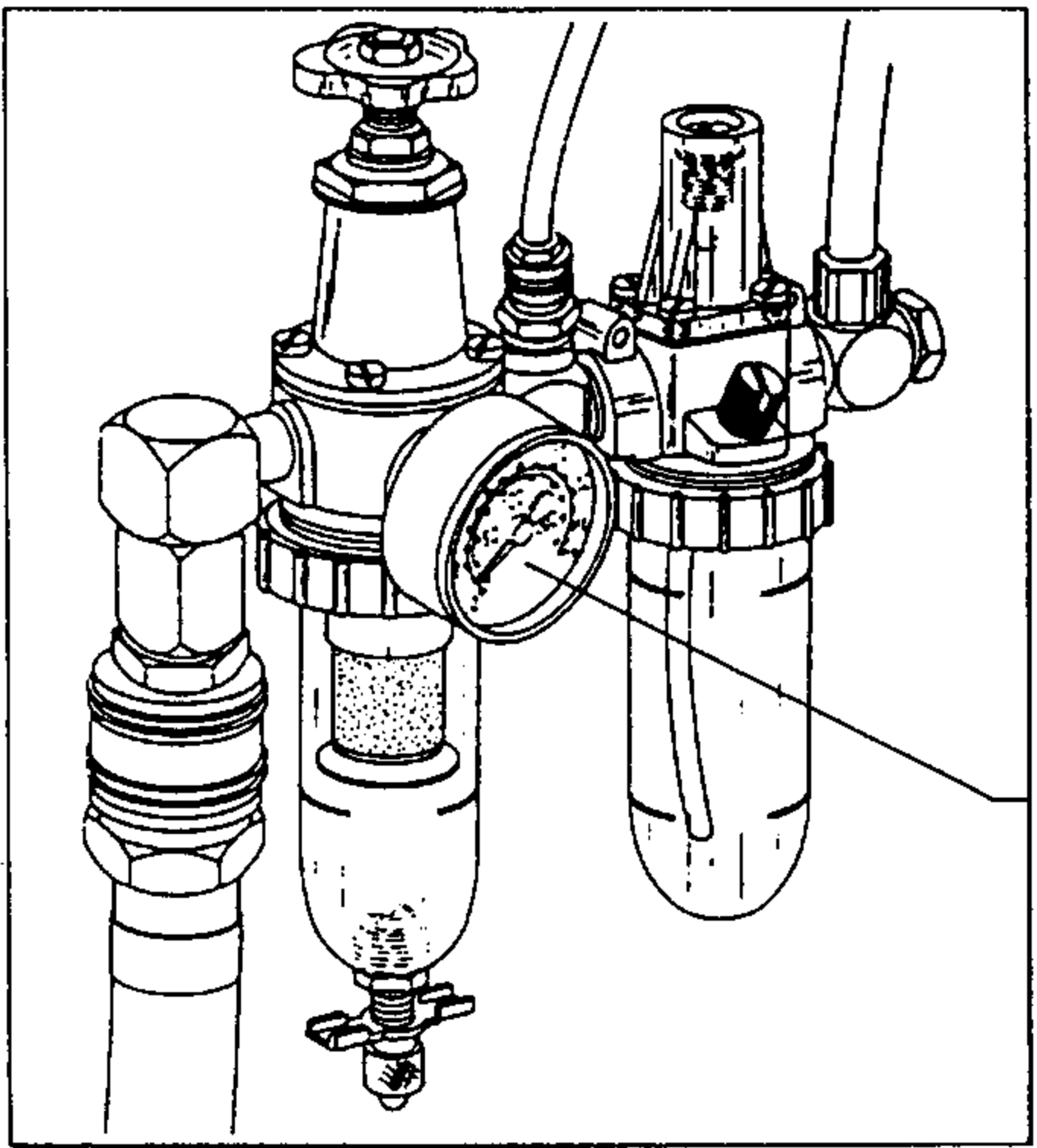

1

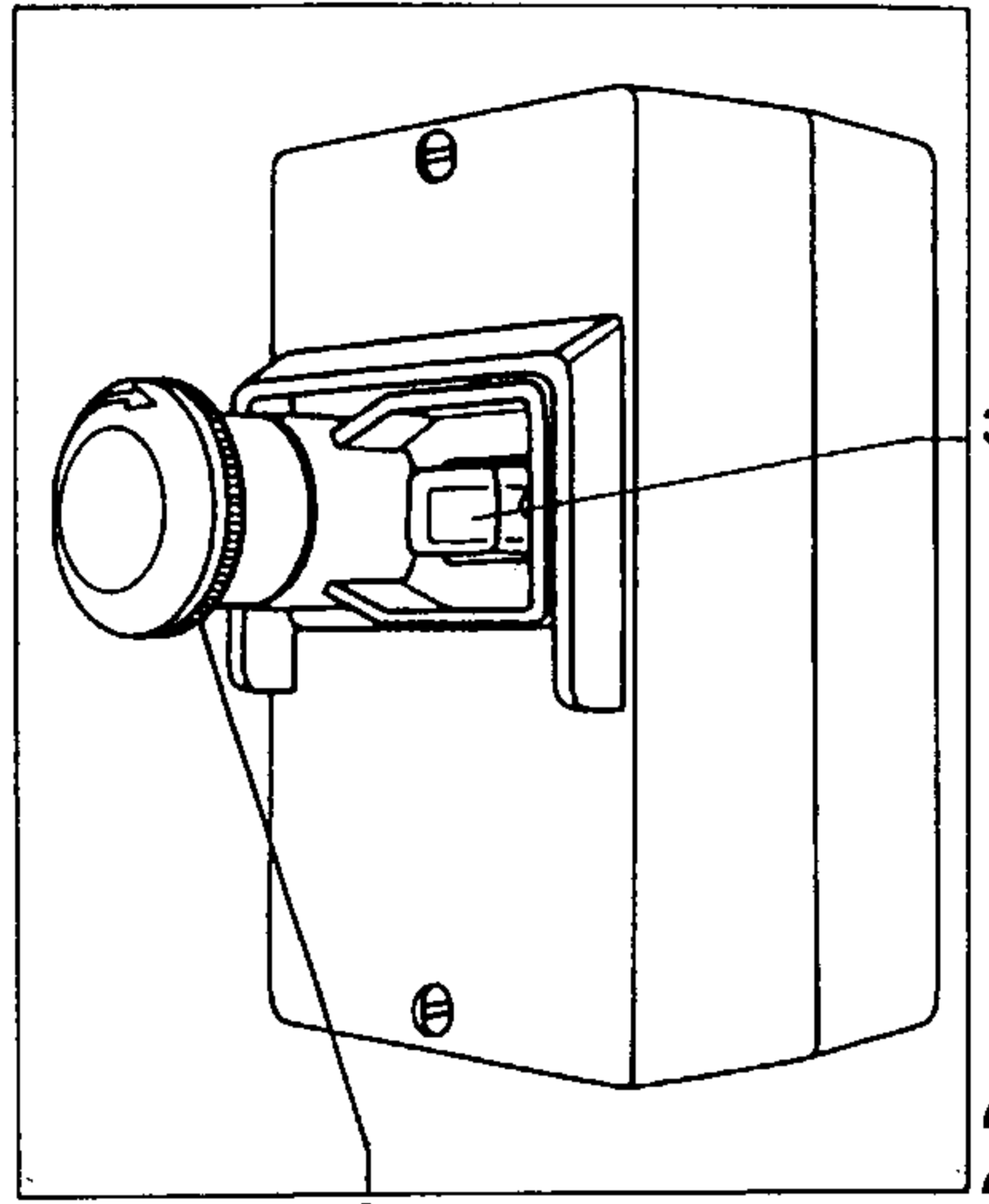

2

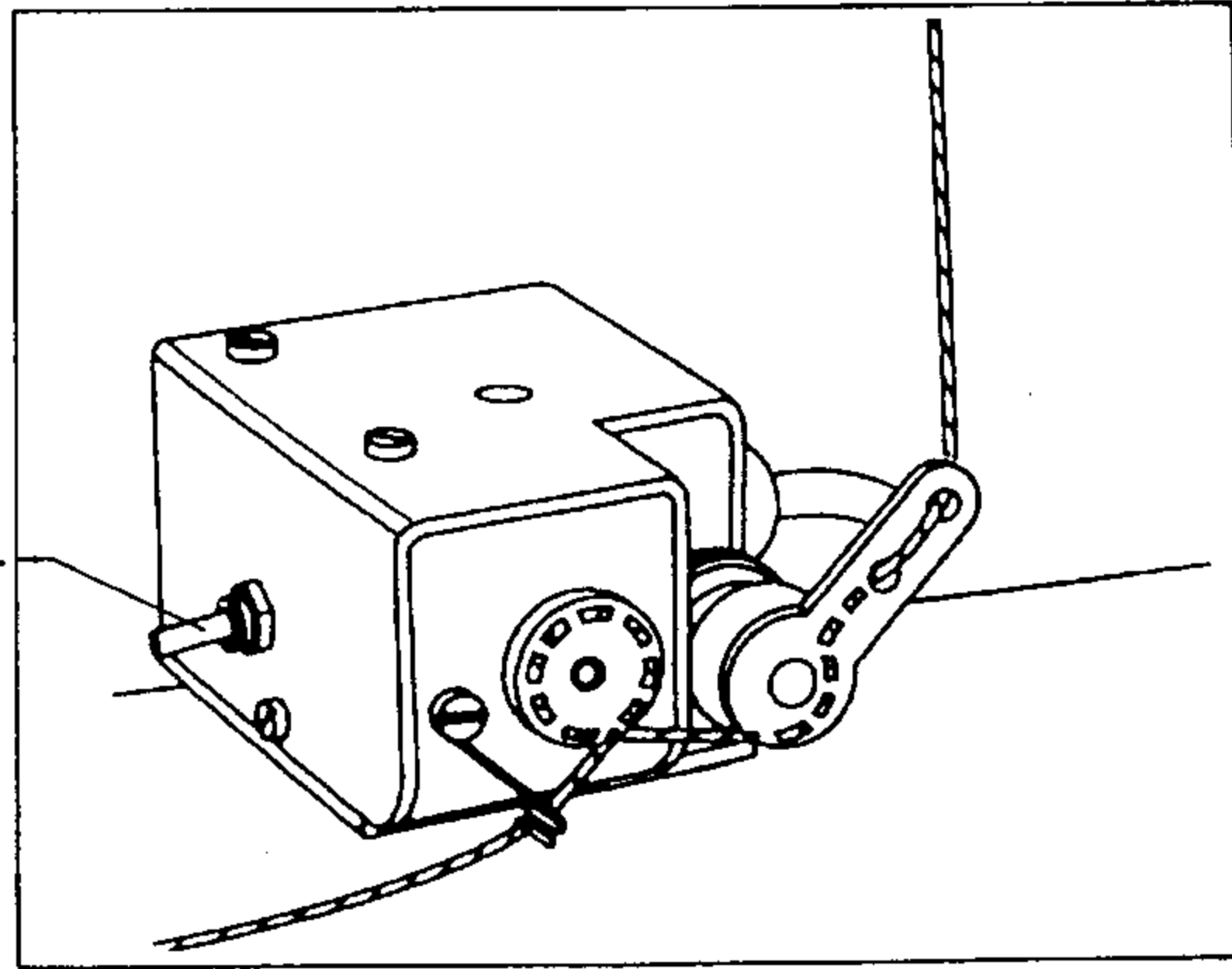

3

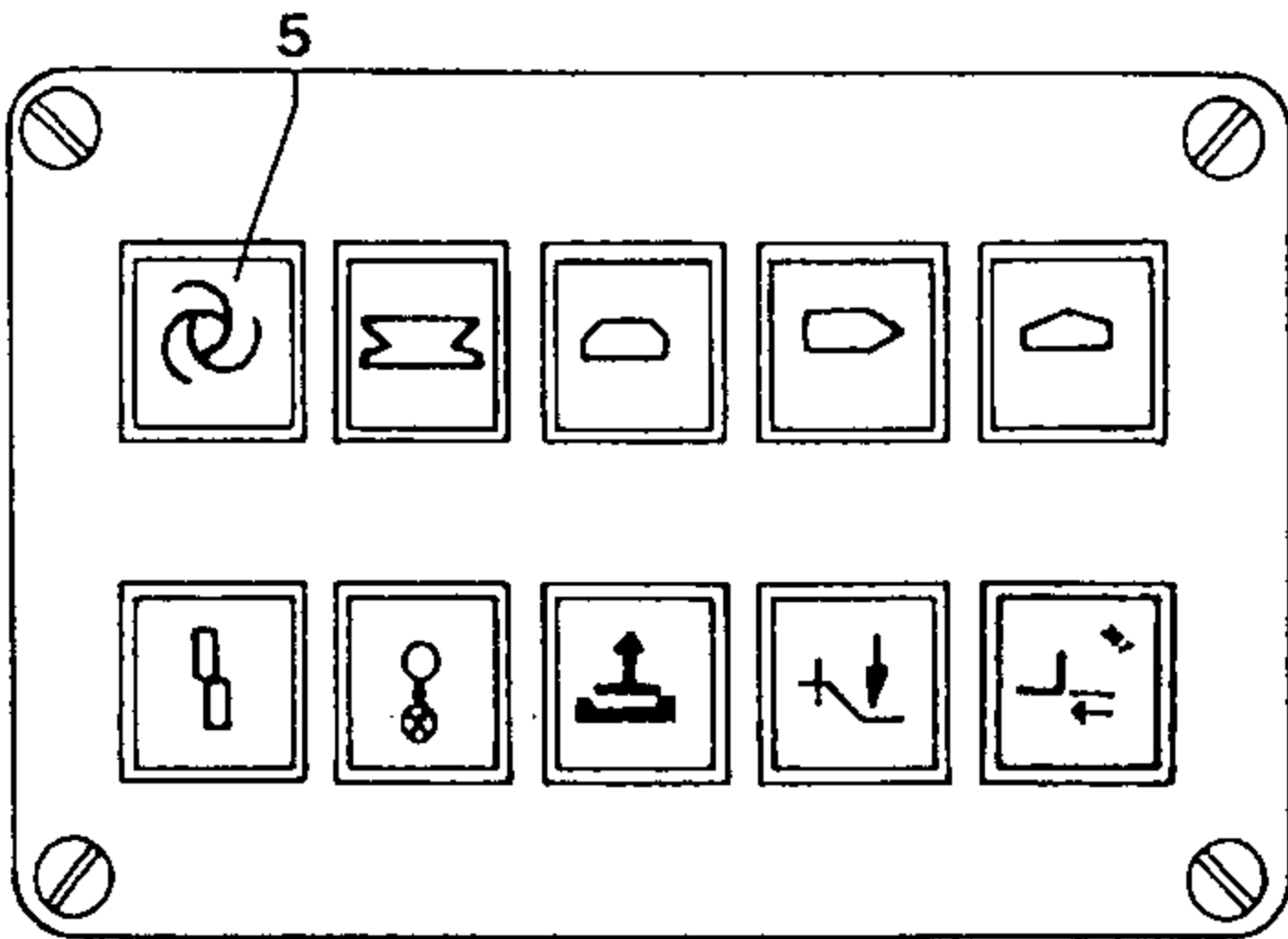

4

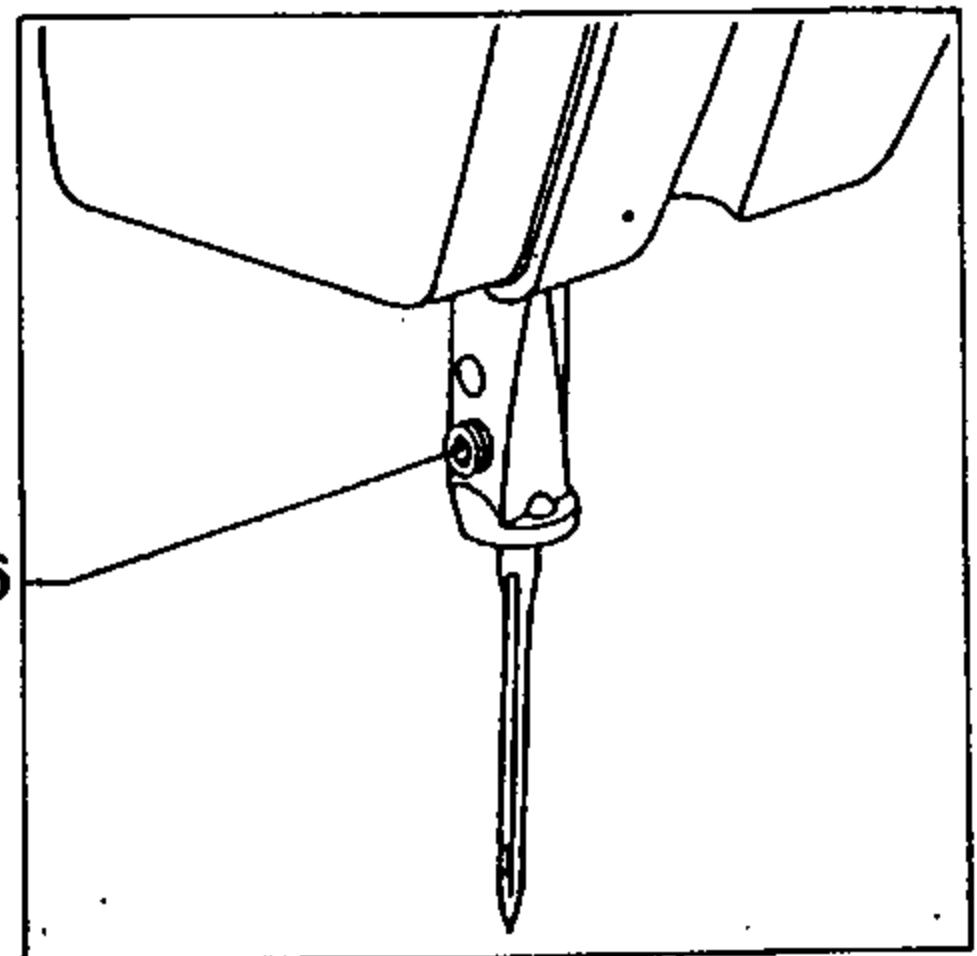

5

3 Bobbin winding

Place an empty bobbin on spindle 1 (Fig. 1).

Push in winder spindle 1.

Thread the machine as illustrated in Fig. 1 and wind a few turns of thread on the bobbin counter-clockwise.

The bobbin winder is in operation during sewing until the bobbin is full and is then switched off automatically.

4 Thread tension regulation for bobbin winding

Turn knurled disc 2 (Fig. 1) clockwise to increase the tension - turn it counter-clockwise to decrease the tension.

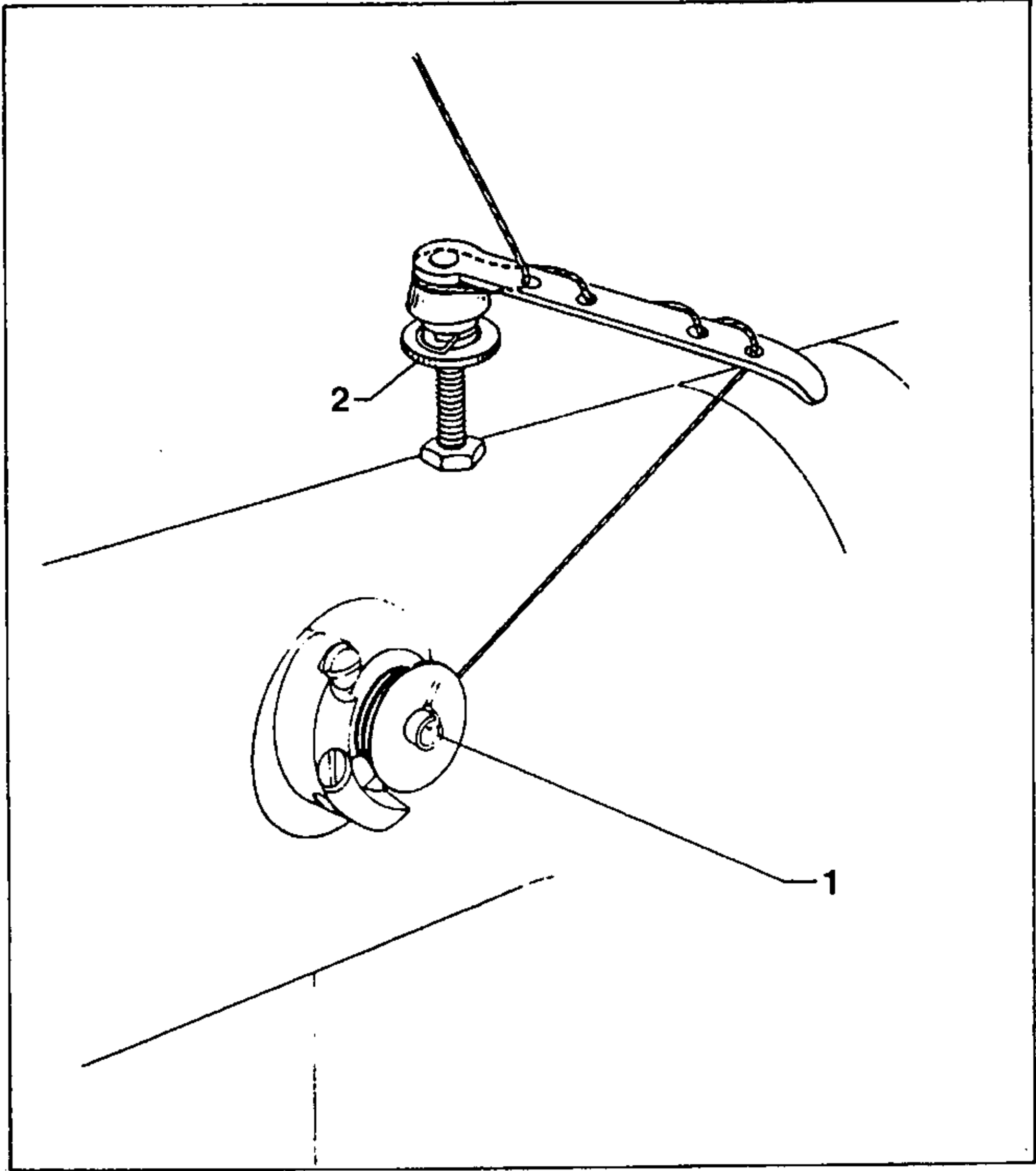

1

5 Removing the bobbin case

Switch off machine

Open latch 1 (Fig. 1) and pull the bobbin case out of the sewing hook.

6 Threading the bobbin

Place a full bobbin into the bobbin case so that it turns in the direction indicated by an arrow when the thread is pulled (see Fig. 2).

Hold the bobbin fast, draw the thread into slot 2 and pull it under the tension spring until it emerges at the rear tip of spring 3.

7 Regulating the bobbin thread tension

To increase the tension, turn screw 4 (Fig. 2) clockwise, to decrease the tension, turn it counter-clockwise.

8 Inserting the bobbin case

Open latch 1 (Fig. 1)
- the bobbin can thus not fall out of the bobbin case.

Insert the bobbin case in the sewing hook and release latch 1.

Lightly push against the bobbin case until it snaps in place.

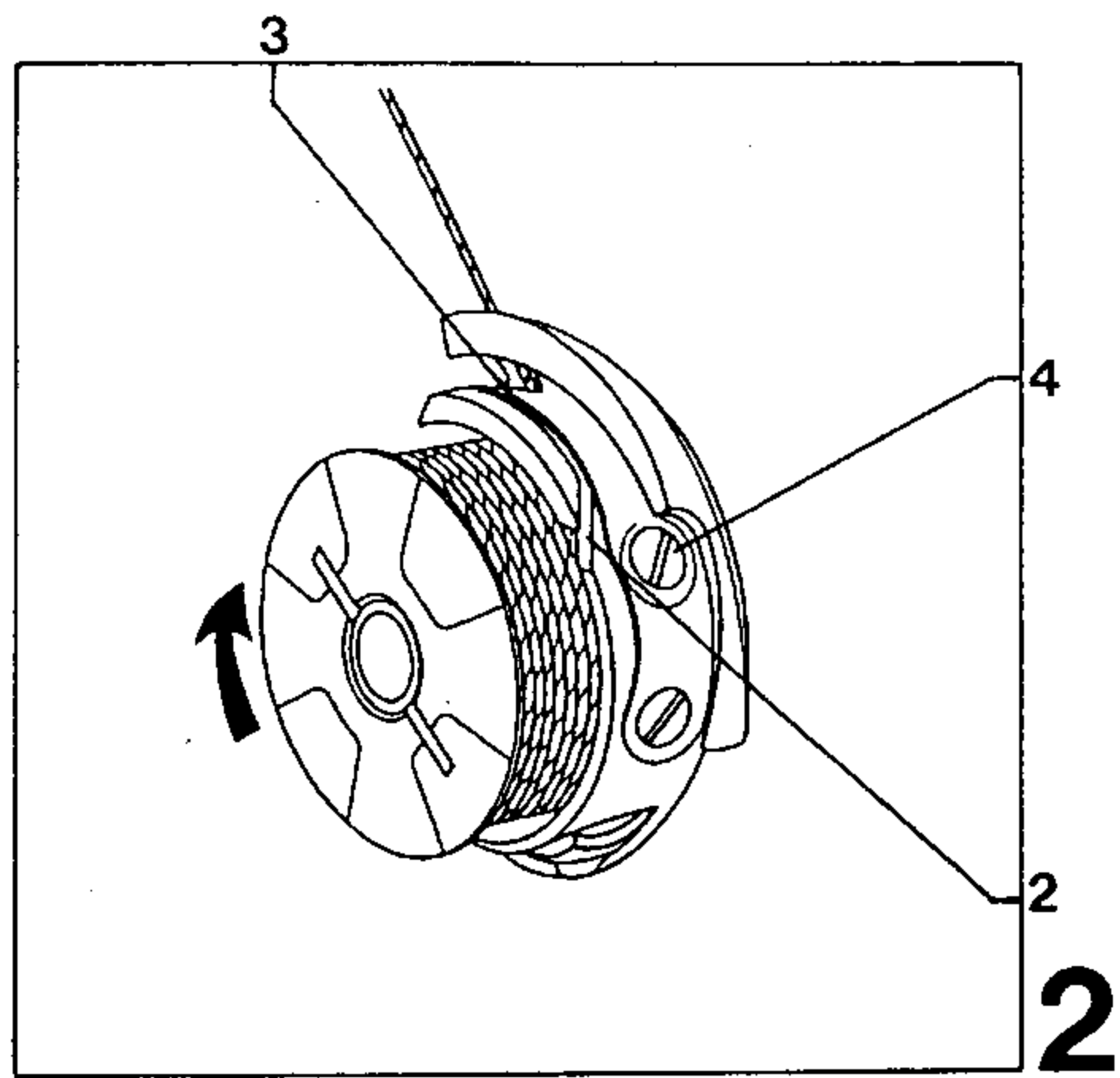
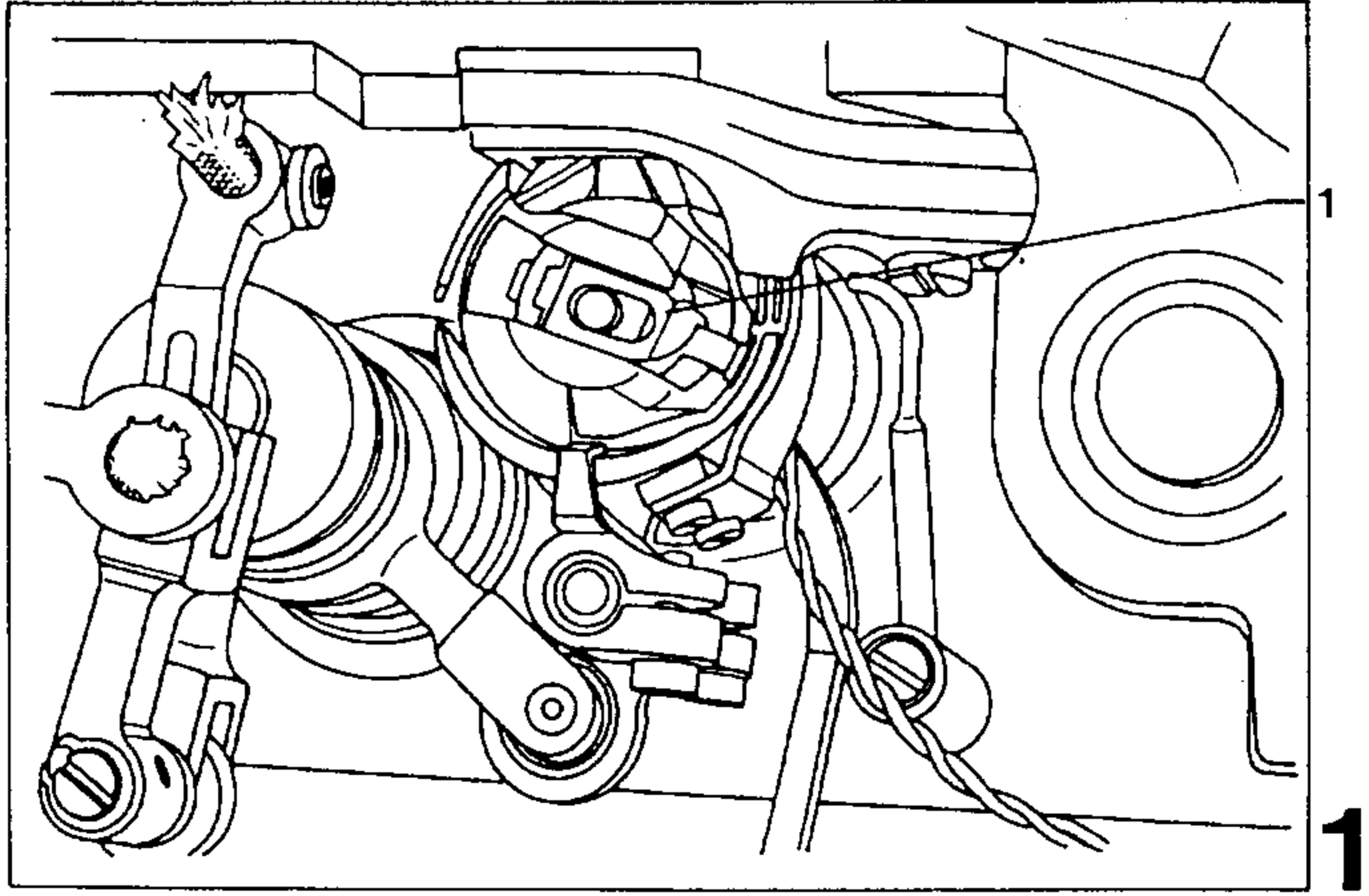

9 Threading the needle

Switch off machine.

Thread needle as illustrated in Fig. 1.

Pull about three inches of thread through the needle eye to prevent unthreading of the needle when sewing begins.

10 Regulating the needle thread tension.

To increase the tension, turn nut 1 (Fig. 1) clockwise, to decrease the tension, turn it counter-clockwise.

To increase the primary tension, turn nut 2 clockwise, to decrease the tension, turn it counter-clockwise.

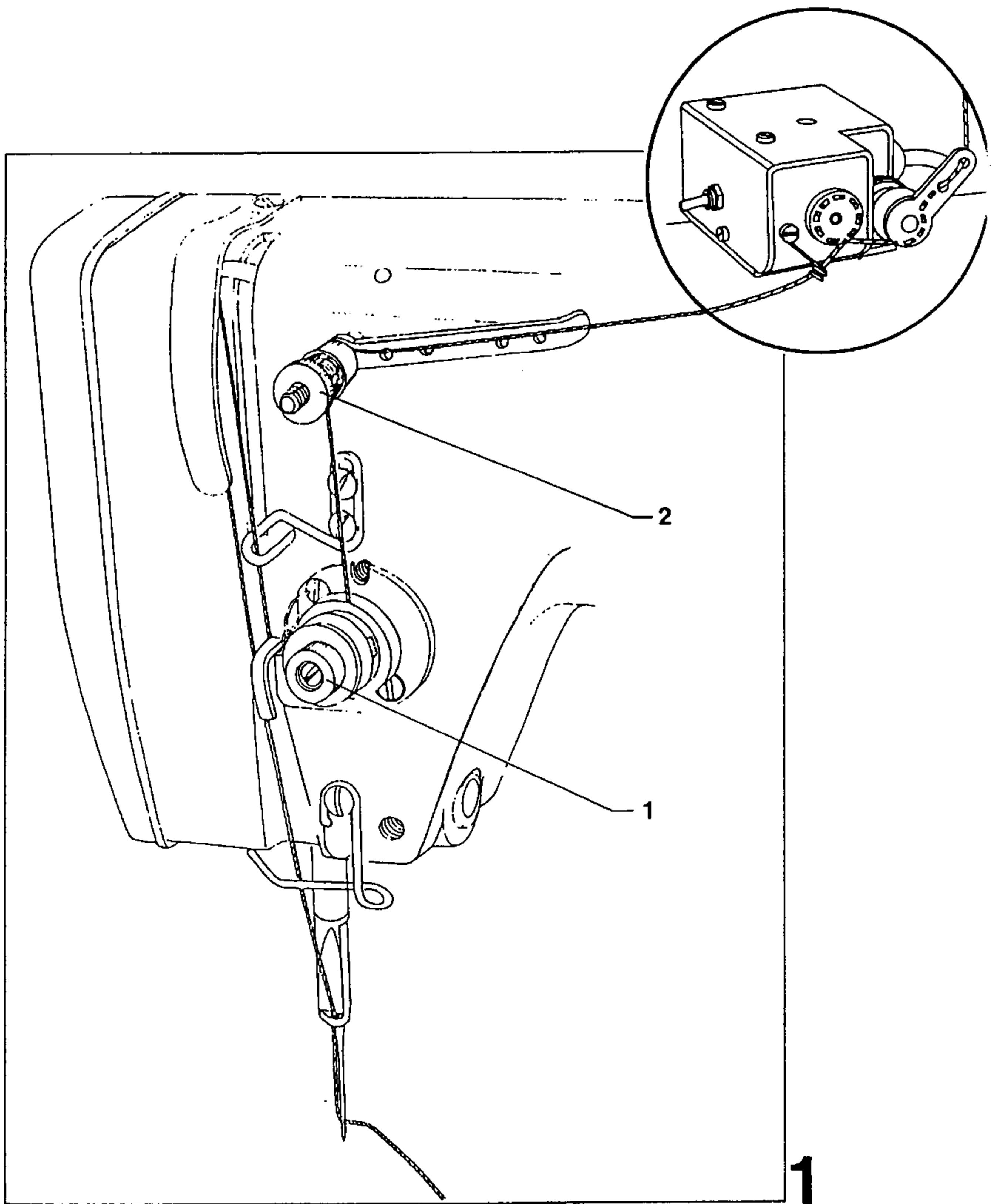

11 Adjusting the stitch length

Push adjusting lever 1 (Fig. 1) to the right and set it at the required stitch length on scale 2.

12 Top feed stroke

Push adjusting lever 3 (Fig. 1) up as far as it will go,
- top feed stroke limitation cancelled.

Set required top feed stroke at adjusting lever 4.

- Same value as adjusting lever 1:
bottom and top feed work with the same stroke (Fig. 2).
- Higher value than adjusting lever 1:
Fullness is applied in the top material ply (Fig. 3).
- Lower value than adjusting lever 1:
Fullness is applied in the bottom material ply (Fig. 4).

13 Presser foot height

The presser foot height depends on the material. It must be set
so that the workpiece is optimally fed.

Loosen knurled nut 5 (Fig. 5).

Set presser foot height by turning knurled screw 6 in or out,
respectively.

Tighten knurled nut 5.

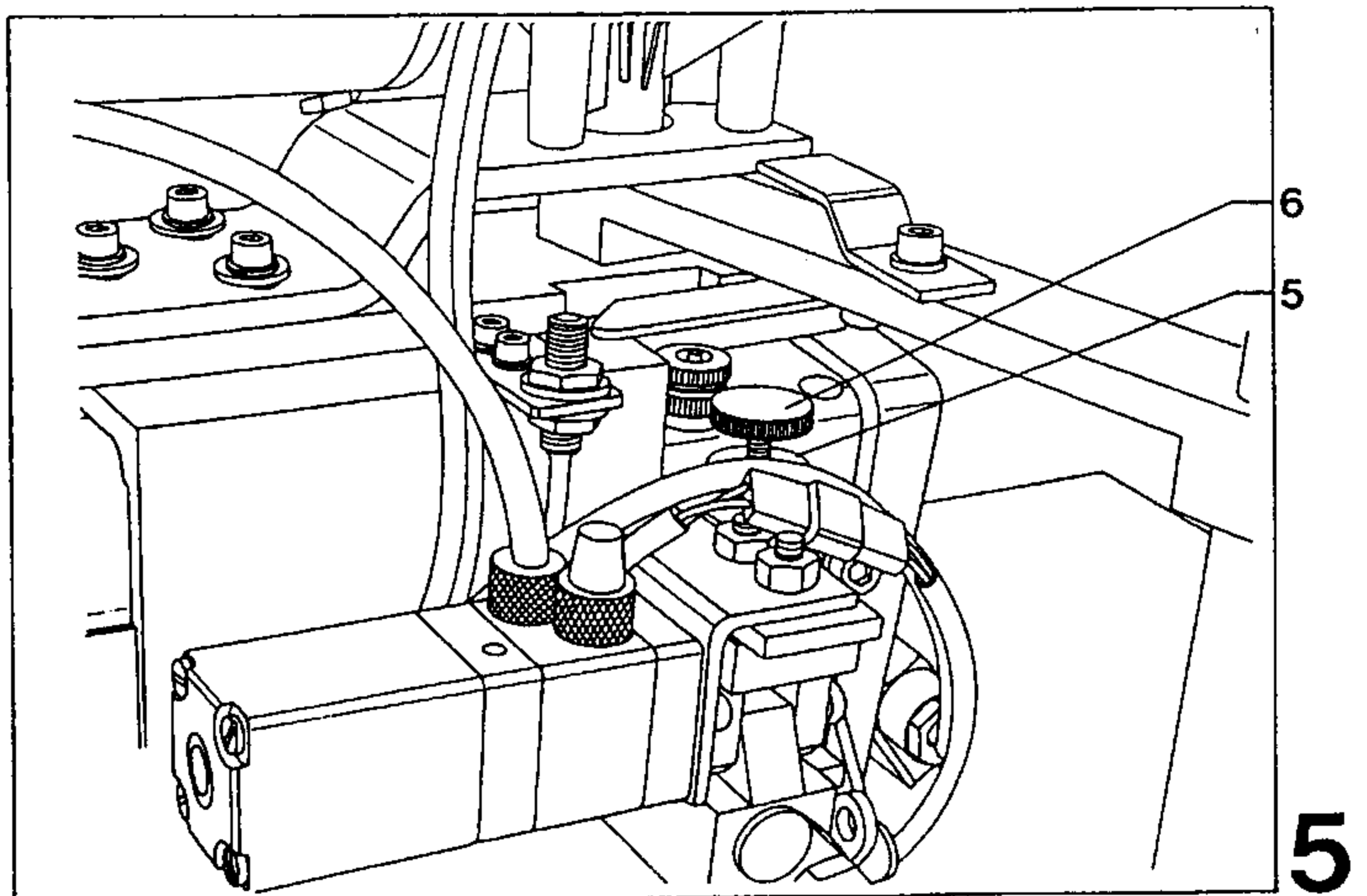
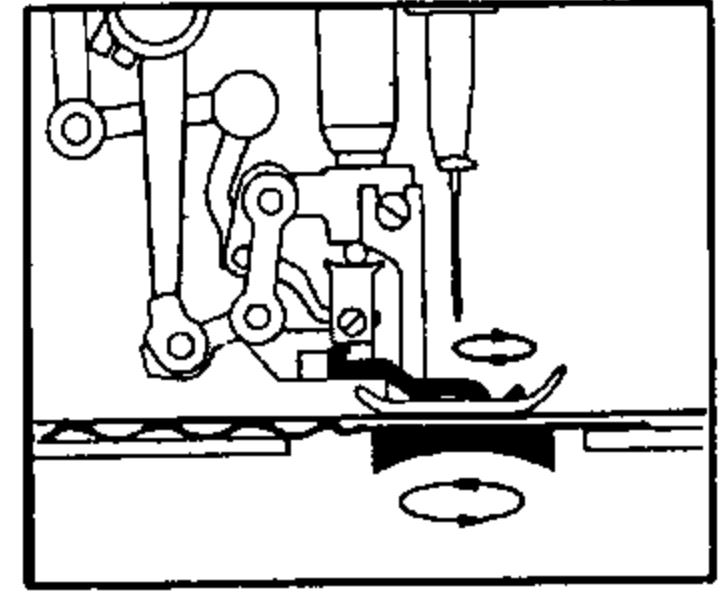
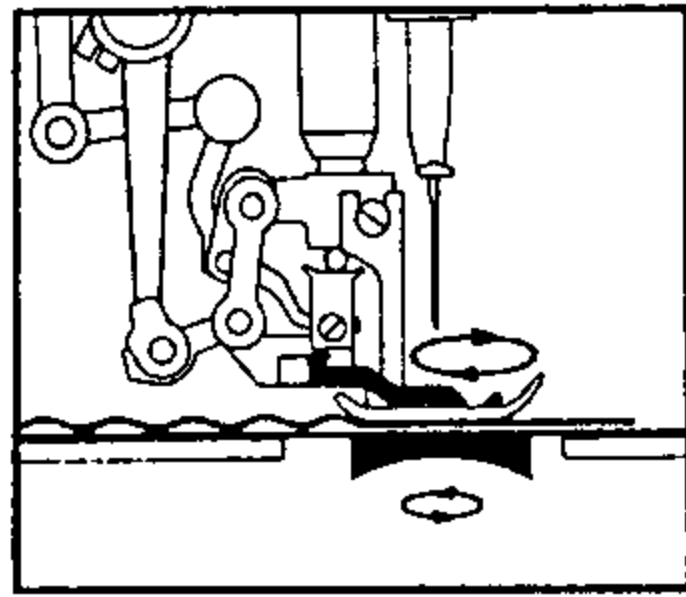
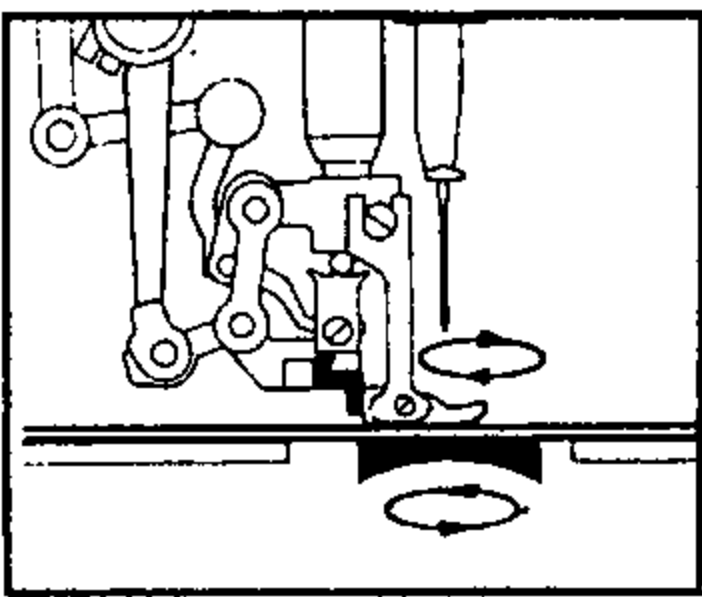
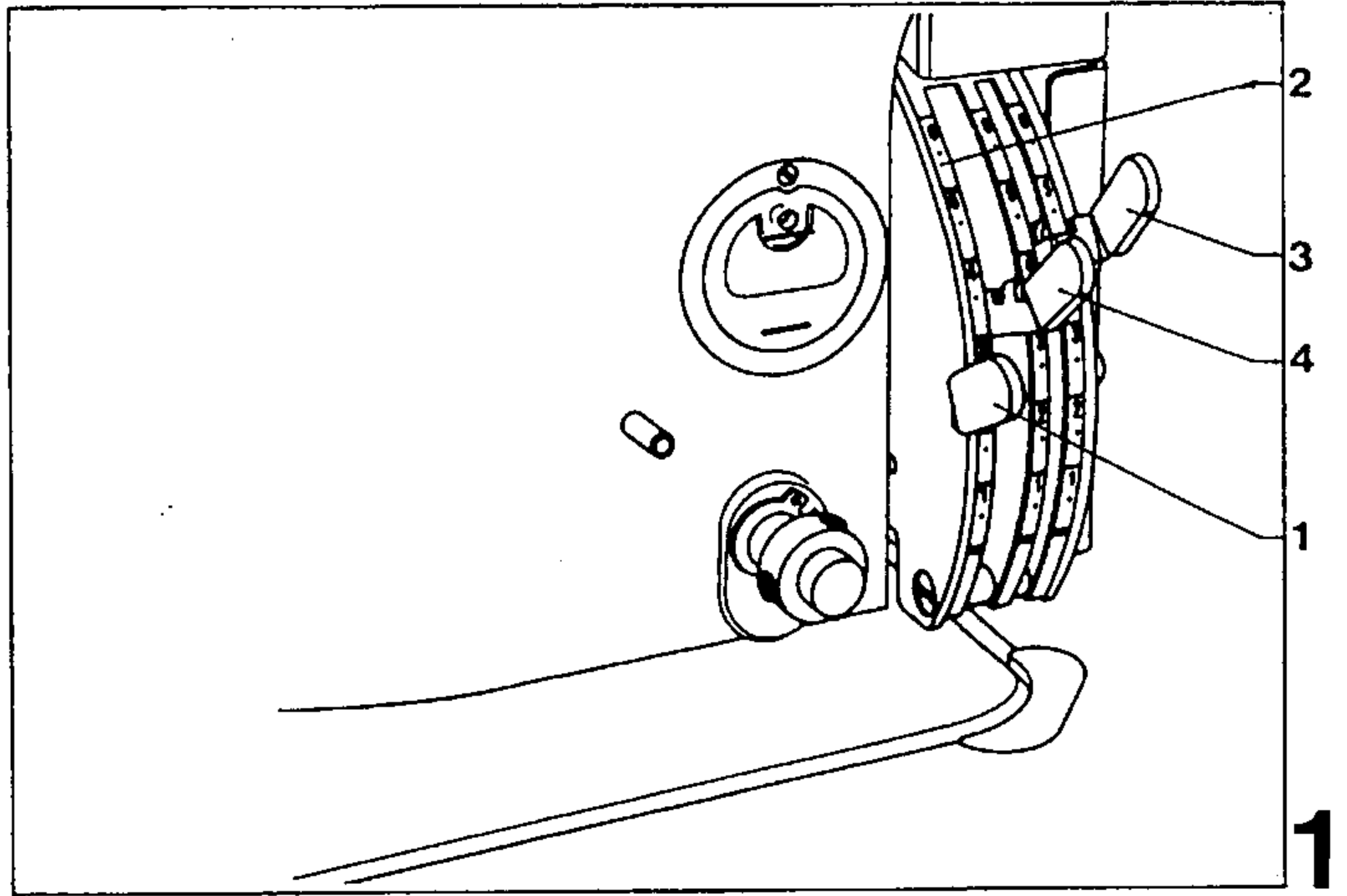

14 Workpiece retainer

The pressure of workpiece retainer 1 (Fig. 1) depends on the material. It must be set so that the workpiece contacts guide 2 during the whole sewing operation.
(From our experience, we recommend a basic value of 2 bar.)

Unlock adjusting knob 3 by pulling it out.

Set required pressure at pressure gauge 4 by turning adjusting knob 3.

Lock adjusting knob 3 again by pushing it in.

15 Seam depth

The seam depth is adjustable between 2 and 7 mm. Two different seam depths can be fixed within this adjustment range, and called forward as required at key 5 (Fig. 2).

Loosen screw 6 (Fig. 1).
Set seam depth "1" at adjusting screw 7.

Tighten screw 6.

Loosen screw 8.
Set seam depth "2" at adjusting screw 9.

Tighten screw 8.

Call the seam depths forward at key 5 (Fig. 2),
key not pressed = seam depth "1"
key pressed = seam depth "2"

When the seam depth is changed, the respective seam program for this seam depth has to be selected at key 15 of the Sensewmat.

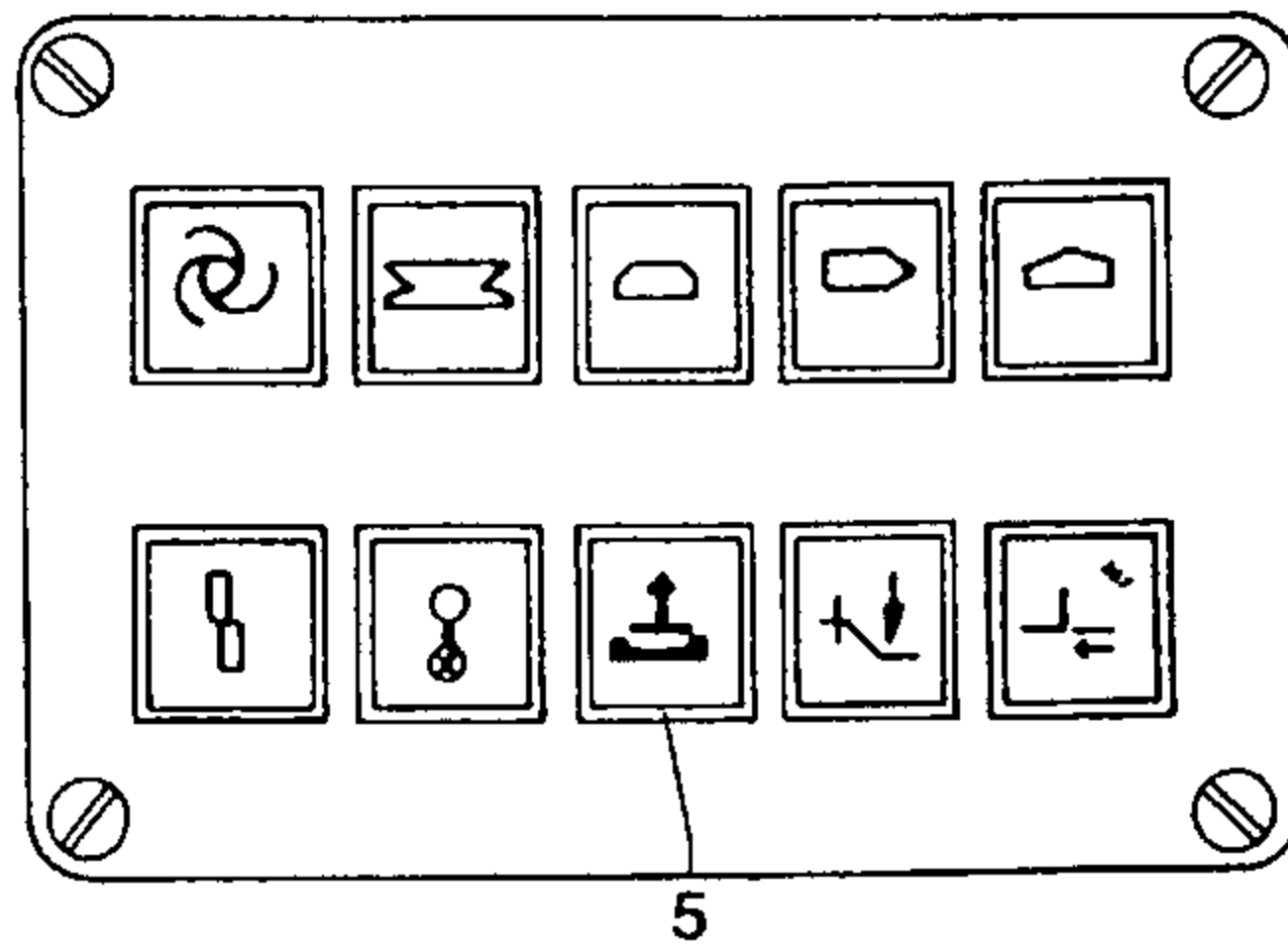
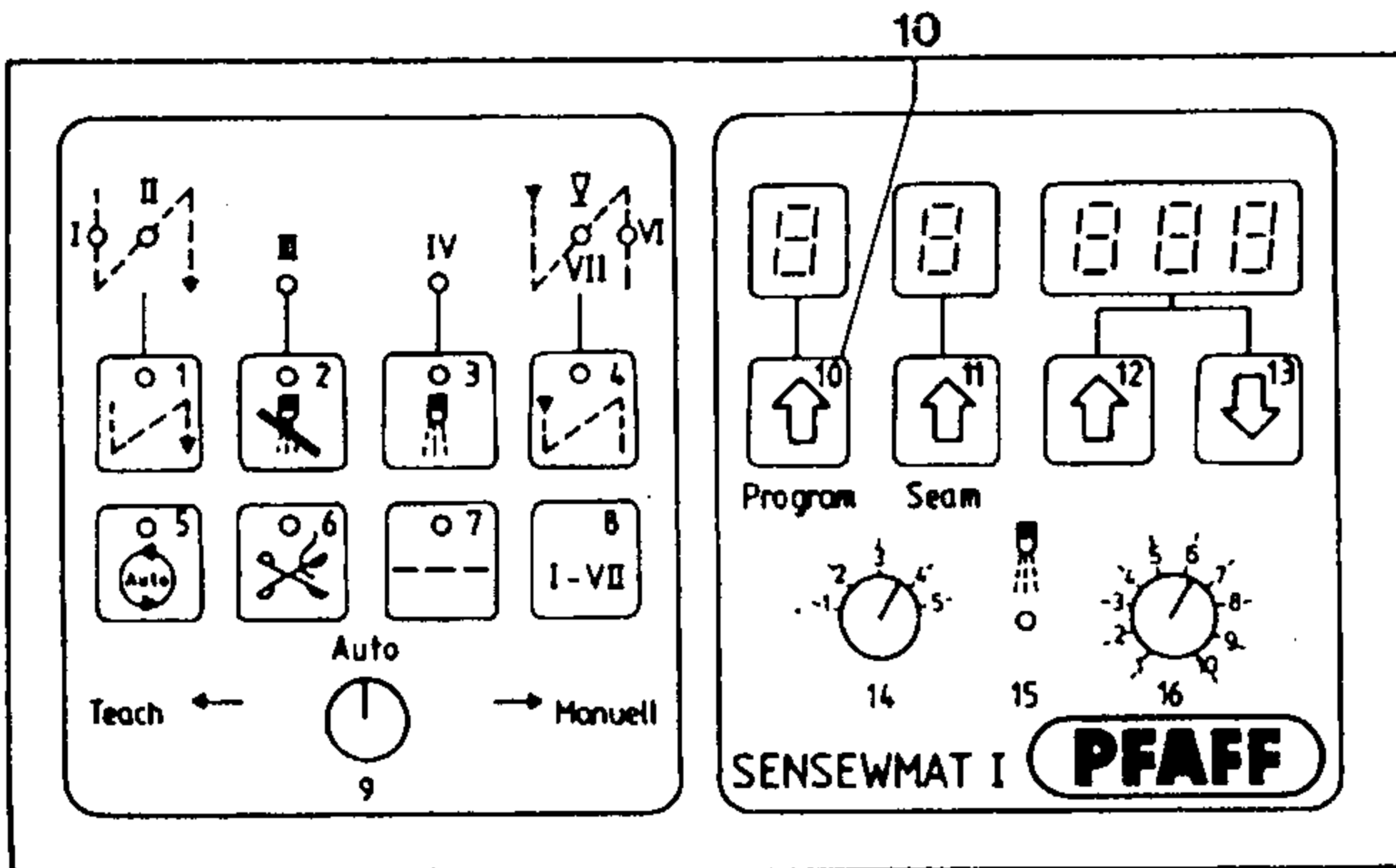
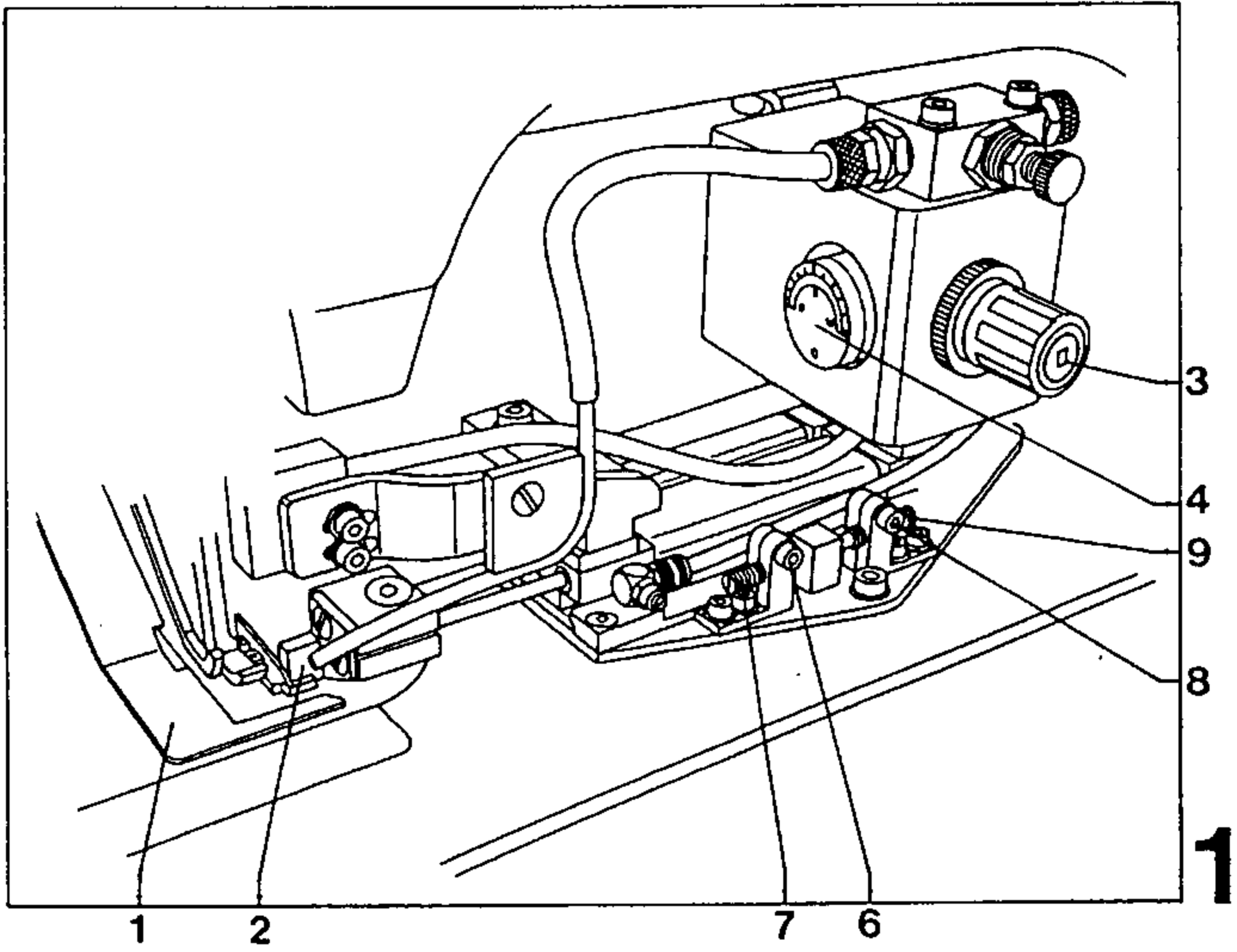

2

16 Program selection

Press key  ,
- key lights up,
- automatic control switched on.

Press required program key at control panel 1 (Fig. 1)
- the respective key lights up.

 one-piece collars
(only with subcl. -3/02 and
-3/12)

 diagonal cuffs

 shoulder straps*

 pocket flaps*

If none of the 4 keys is pressed, the machine automatically switches to program for two-piece collars.

After pressing the required program key, press key 2 at control panel 3 repeatedly until the required seam program number appears in display 4.

* With these programs selected, the stacker is switched off.

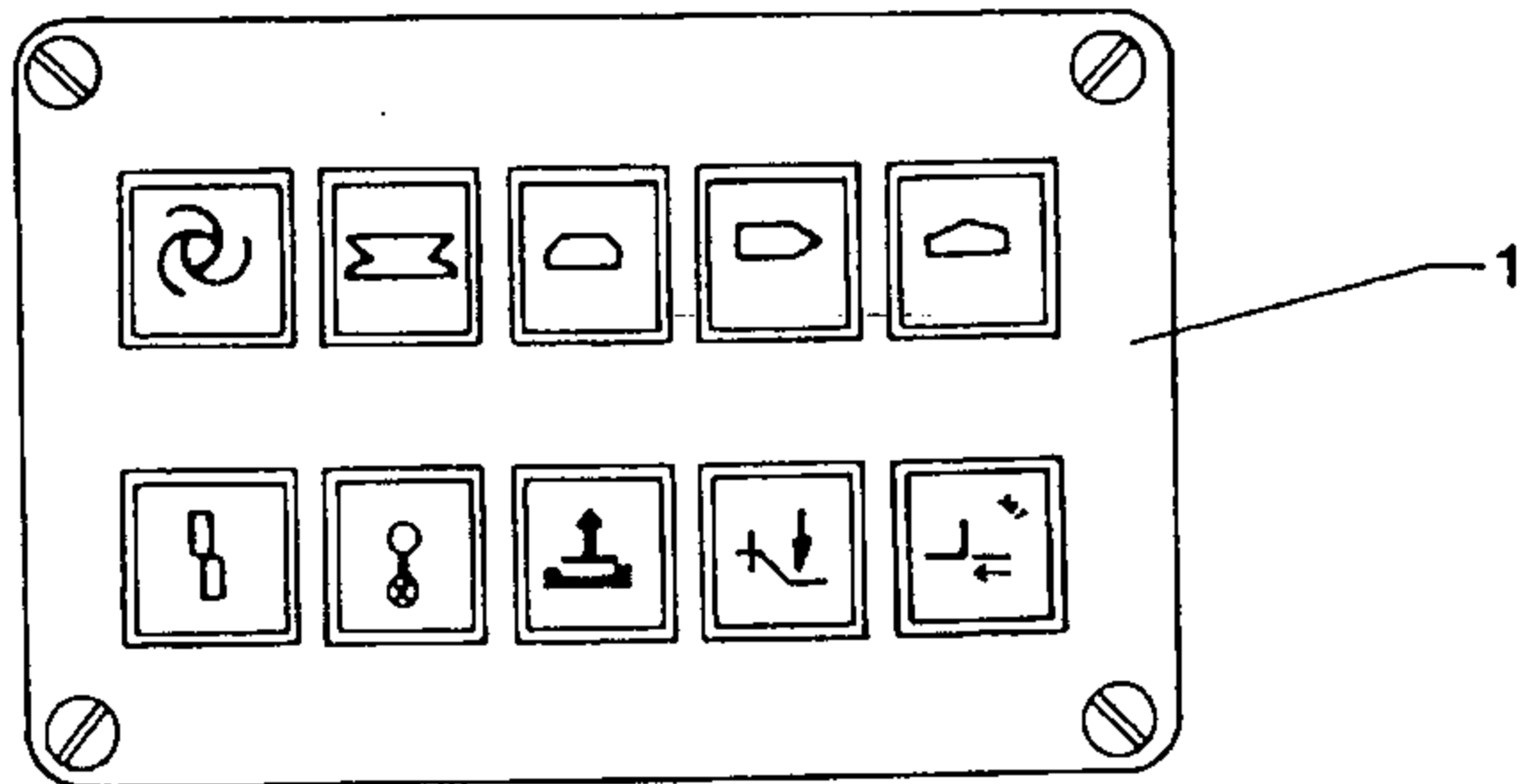
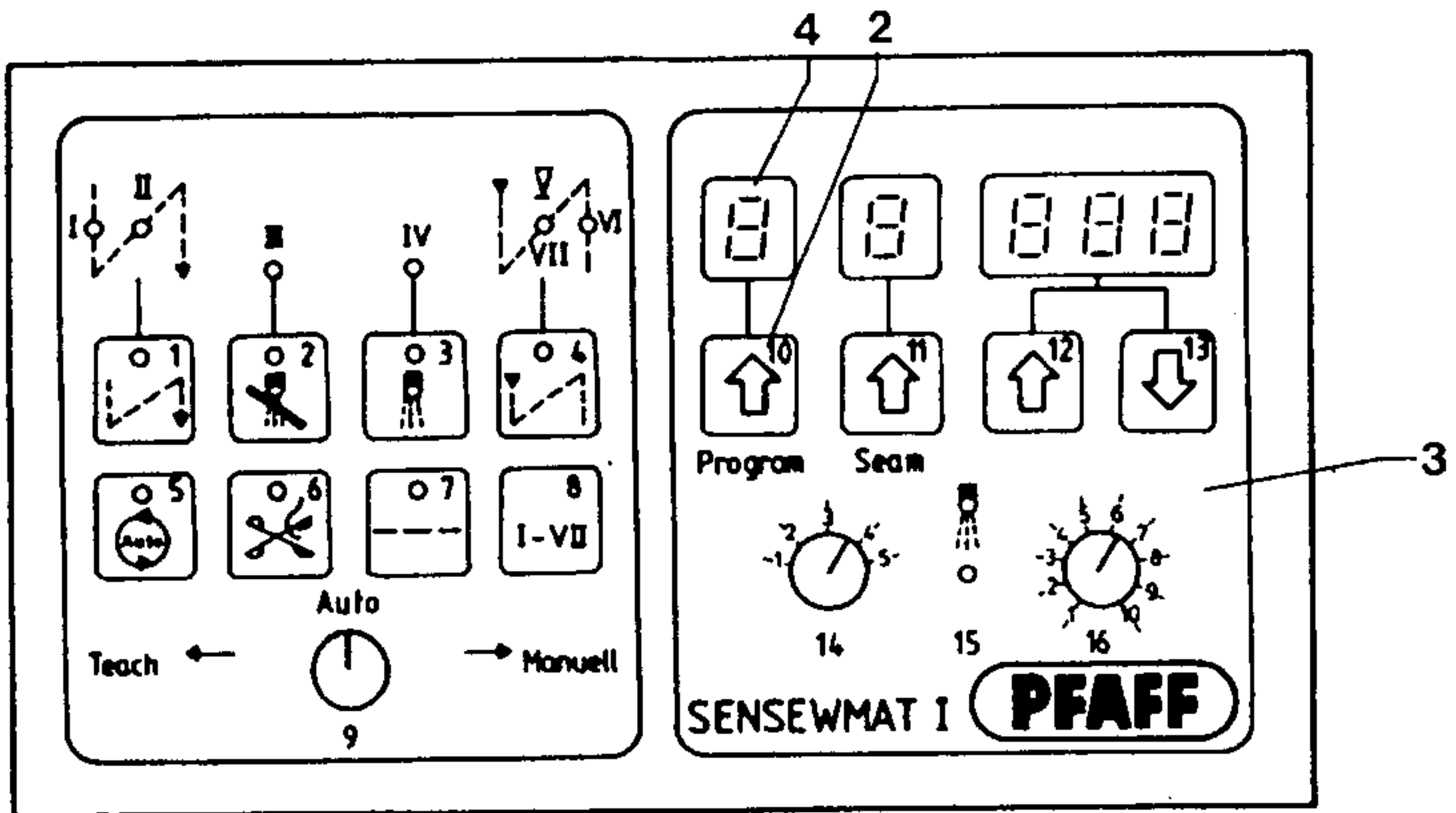

1

17 Inserting the workpiece

17.1 One-piece collars

Set program according to Section 16.

Place workpiece against guide 1 as shown in Fig. 1.

17.2 Two-piece collars, cuffs, shoulder straps, and pocket flaps

Set program according to Section 16.

Place workpiece against guides 1, 2, and 3 as shown in Figs. 2, 3,* 4, or 5.

* Guide 3 can be disengaged for certain sewing operations, (i.e. the guide stays up).
To this end, press key 4 (Fig. 6).

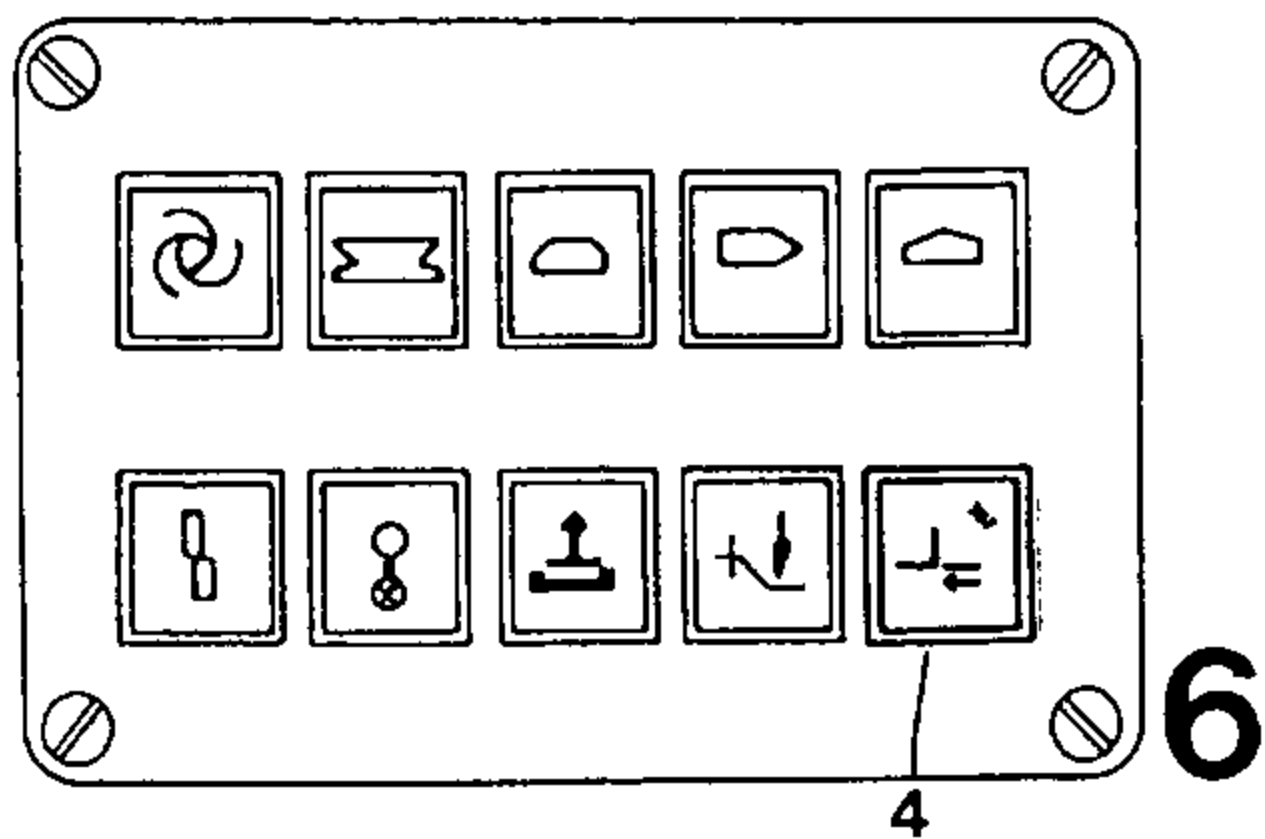
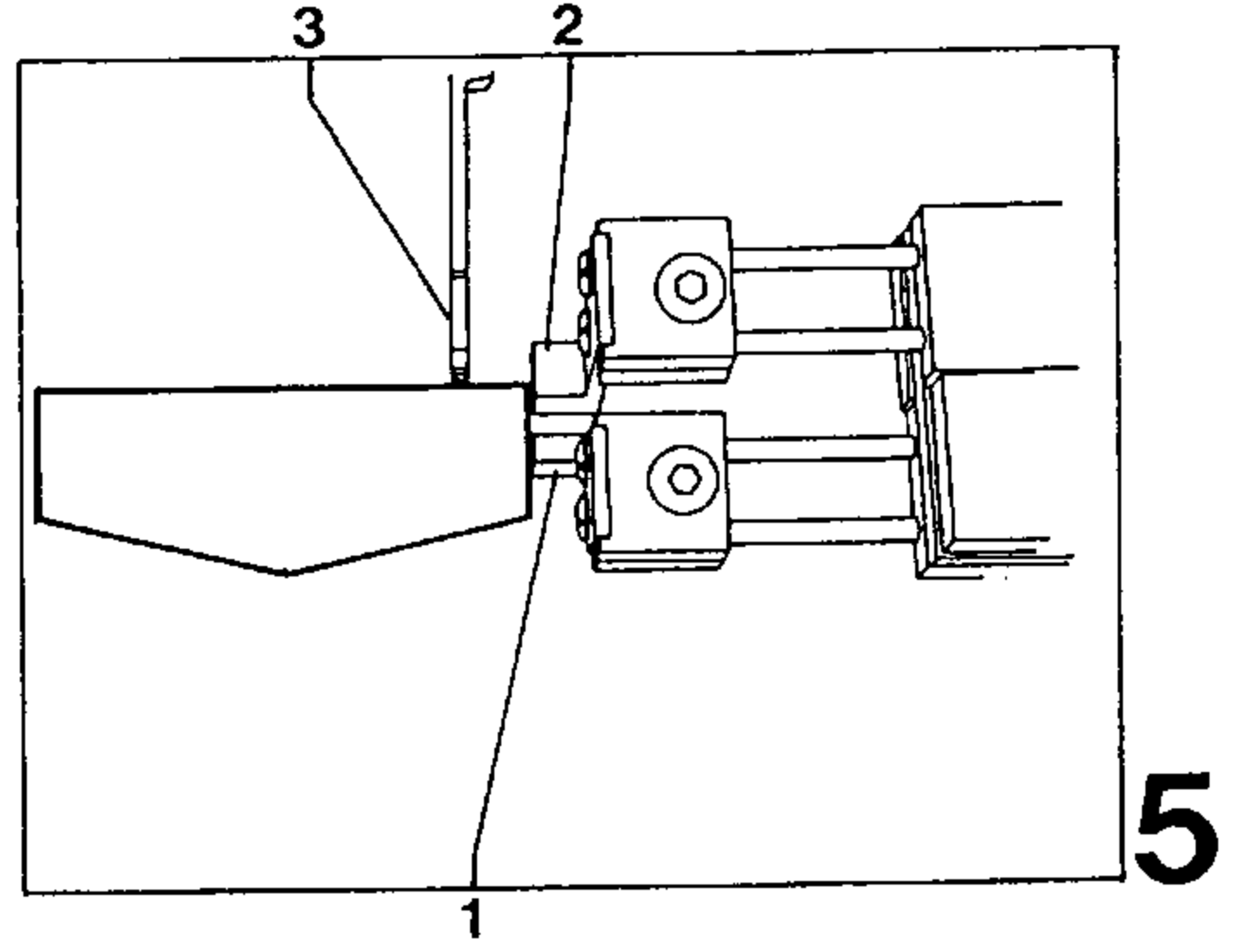
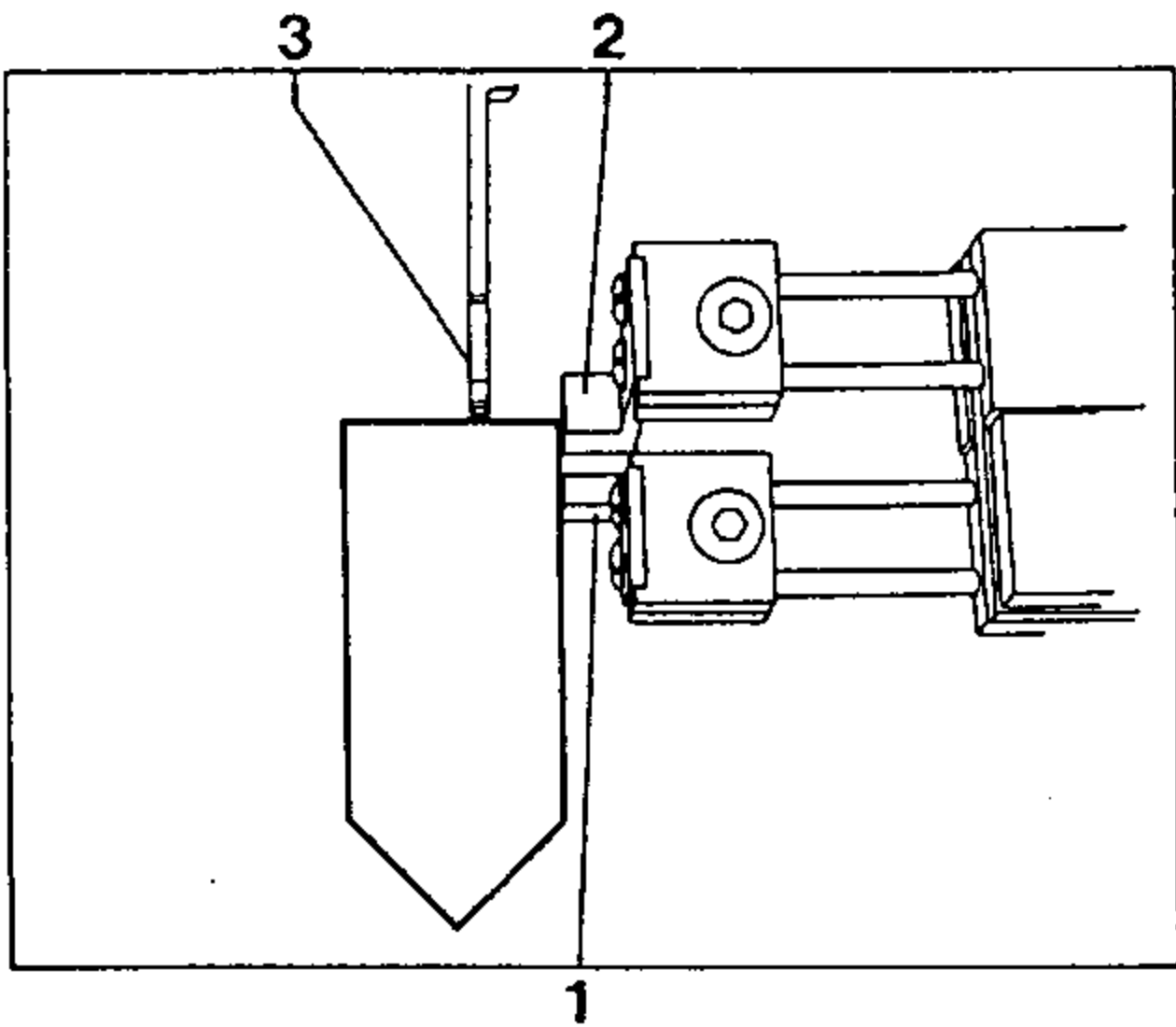
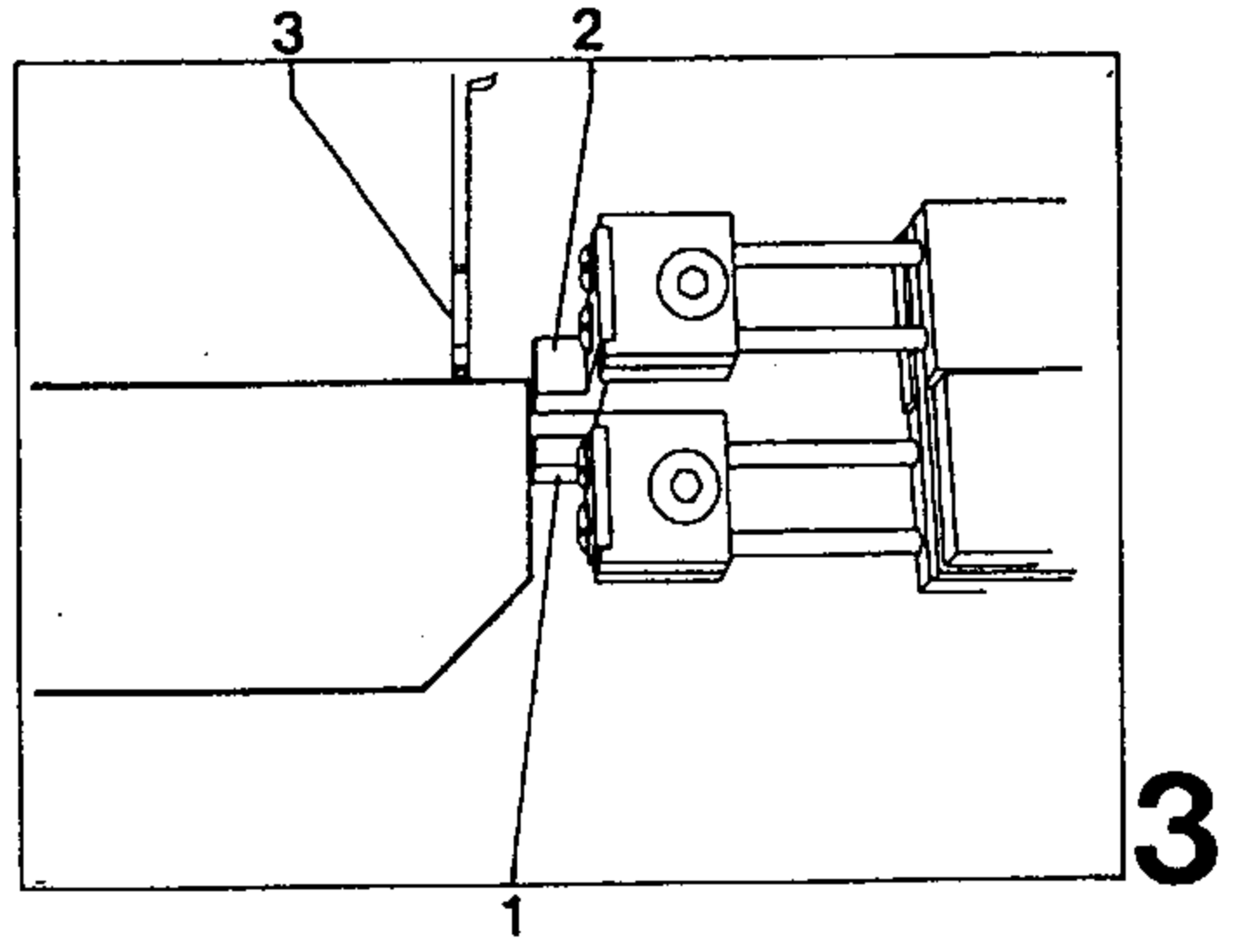
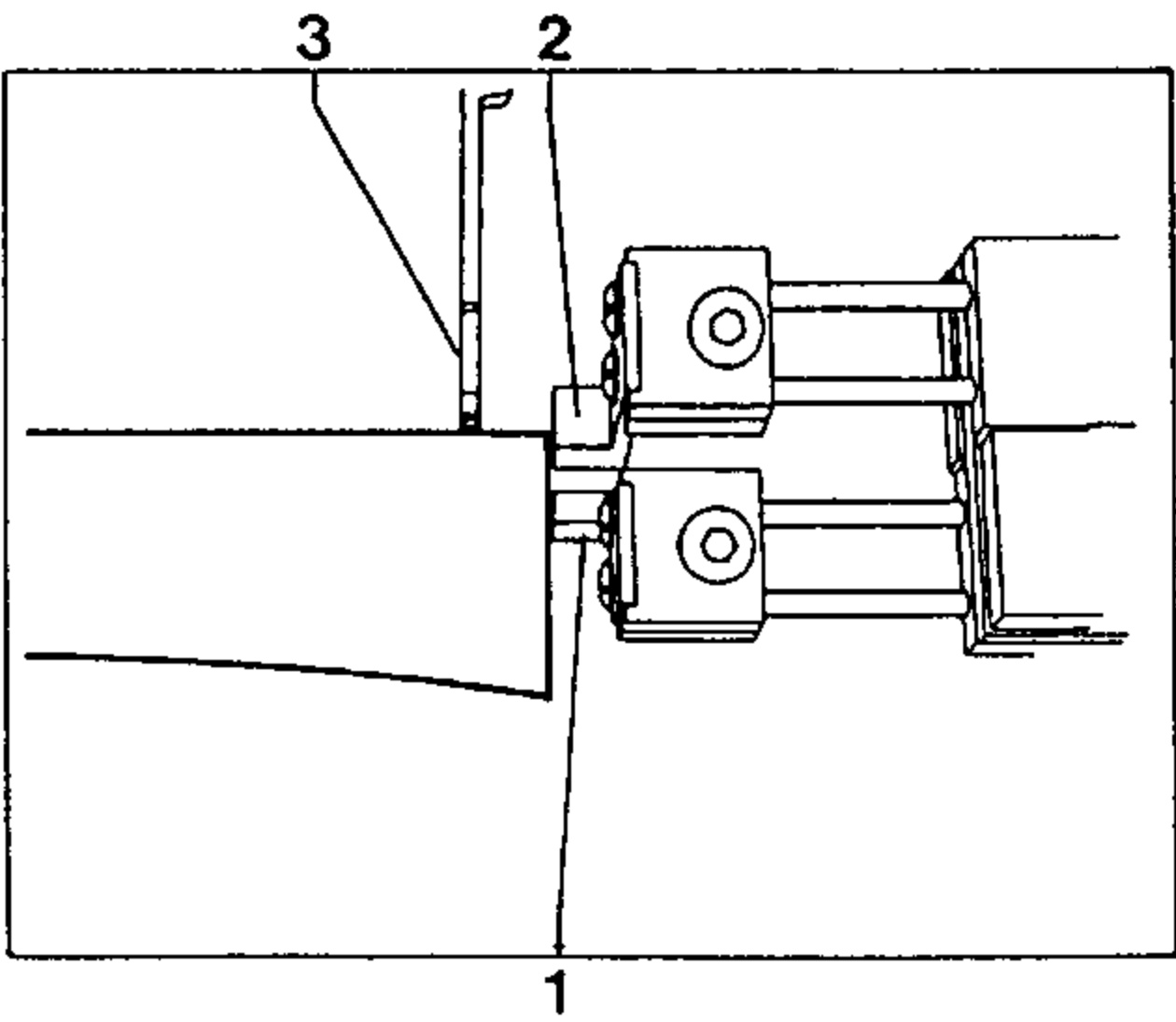
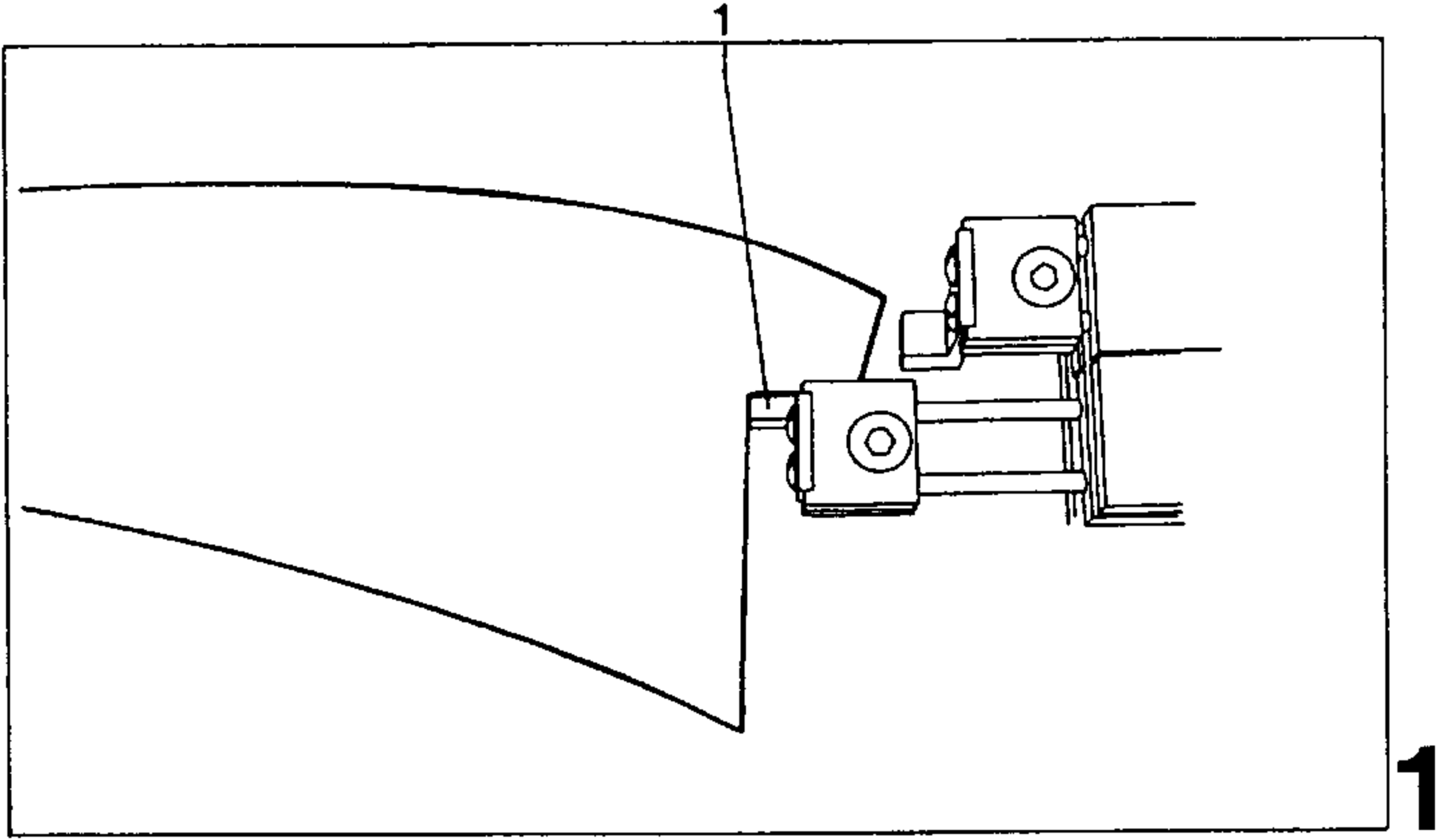

18 Sewing

18.1 With program control

(Key  pressed)

After workpiece insertion according to Section 17,
press key 1 (Fig. 1),
- sewing program runs off automatically.

18.2 Without program control

(Key  not pressed)

Set rotary switch 2 (Fig. 2) at "AUTO".

Press pedal 3 (Fig. 3) backwards to position "3",
- presser foot up.

Insert workpiece according to Section 17.

Press pedal 3 forwards to position "2" (keep pressed),
- presser foot down,
- machine sews up to the end of the 1st seam section,
- machine stops,
- needle remains in the workpiece,
- presser foot is lifted automatically.

Turn workpiece by hand.

Release pedal 3 to position "1",
- presser foot down.

Sew the rest of the seam sections as described for
seam section 1.

At the end of the seam, the machine stops auto-
matically,
- the sewing threads are cut,
- presser foot up
- needle positioned up.

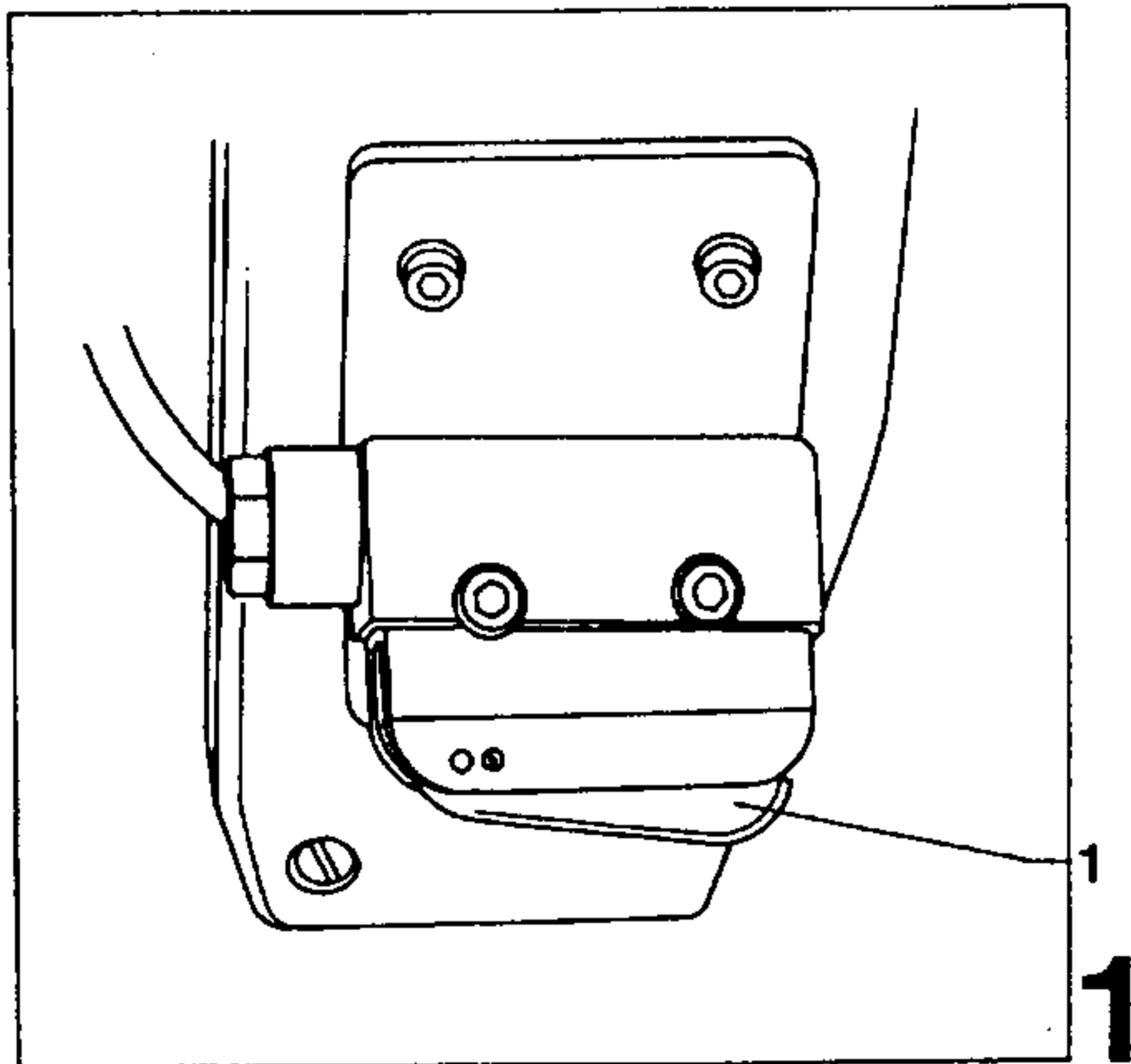

1

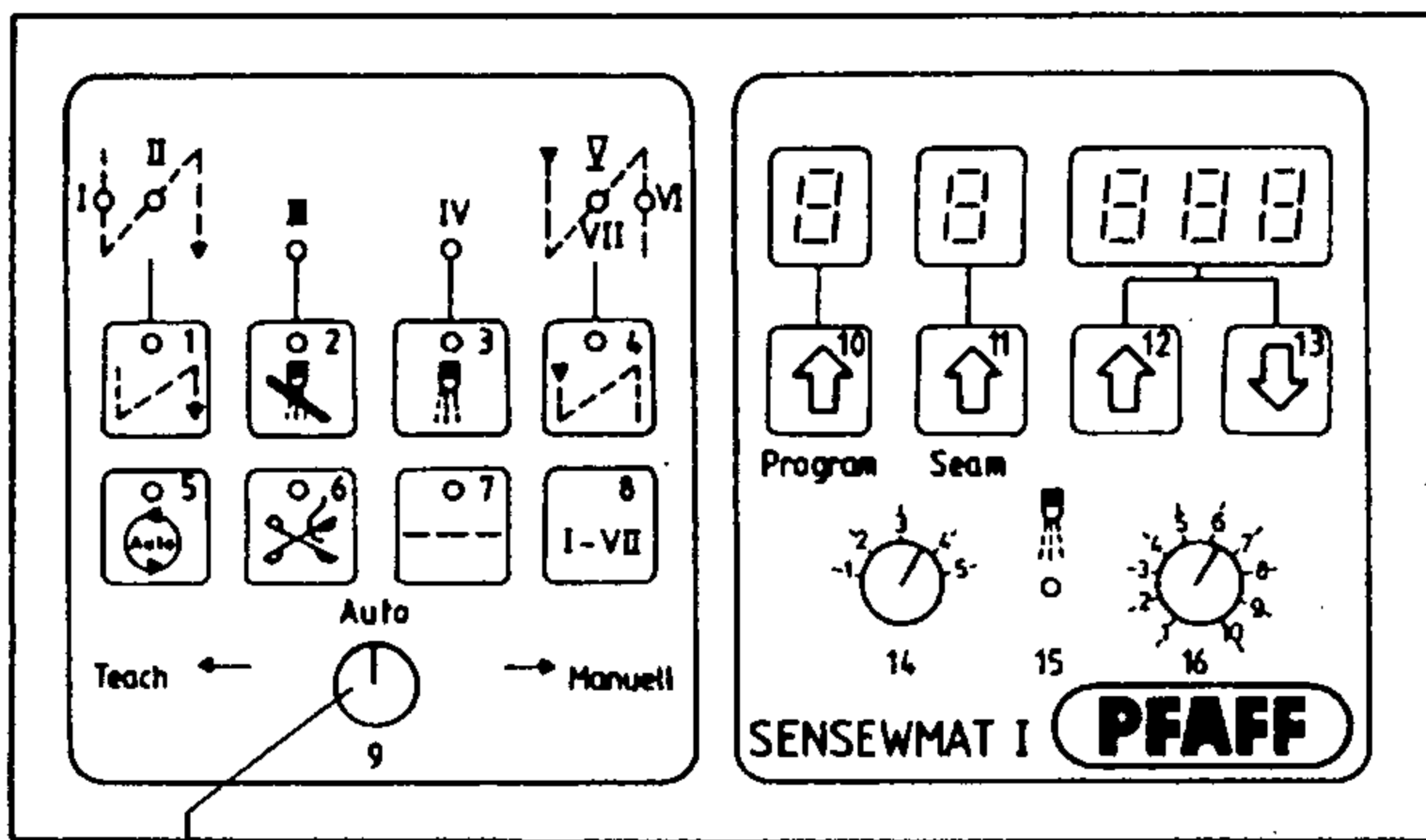

2

2

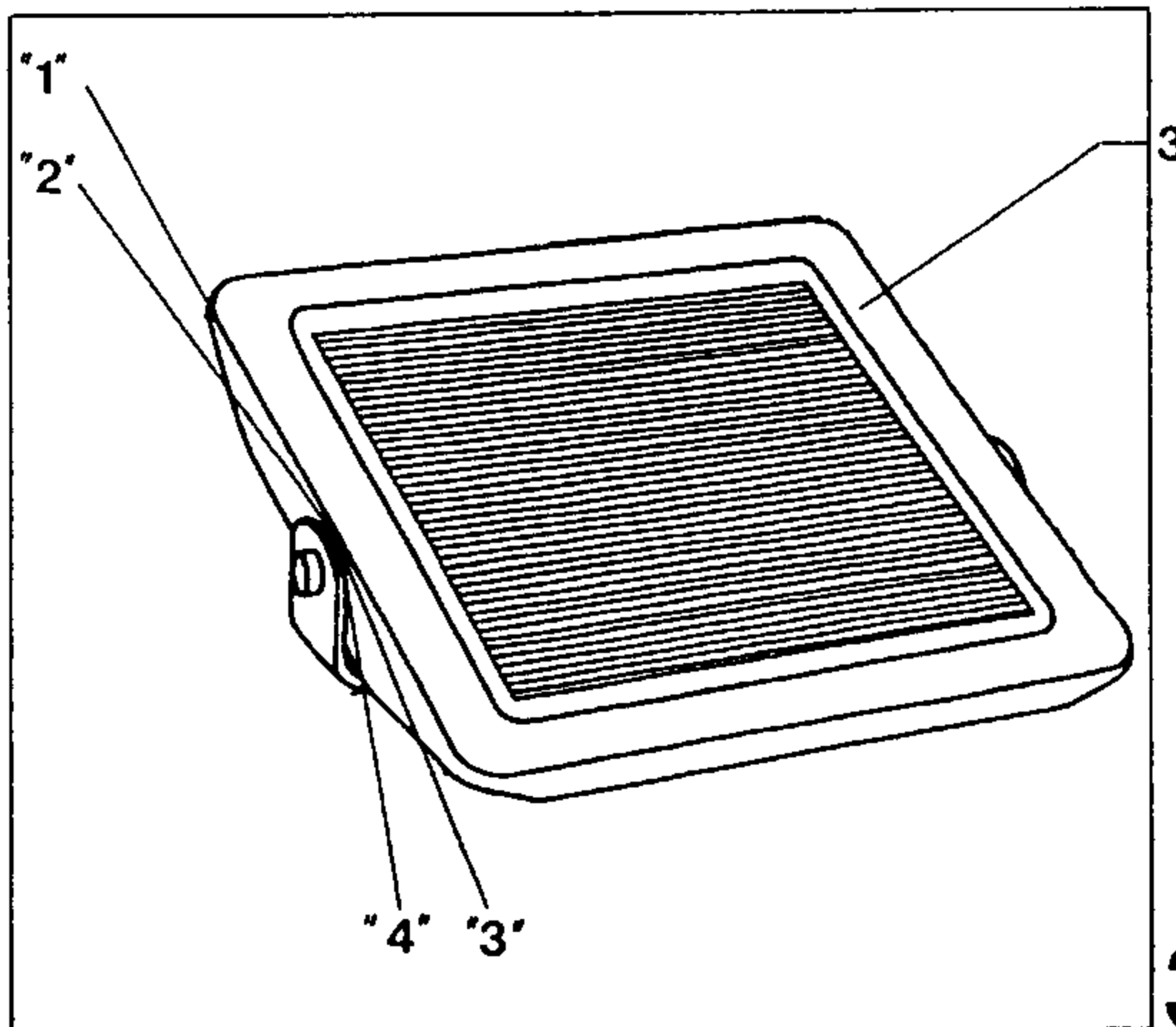

3

19 Exchanging turning plate at the turning head

Two different turning plates can be used, depending on the sewing program selected.

Turning plate 1 (Fig. 1) for
one-piece collars
two-piece collars
square cuffs

Turning plate 2 (Fig. 2) for
shoulder straps
pocket flaps

Loosen screw 3 (Fig. 1).

Lift cylinder bar 4 a little and hold it.

Change turning plate.

Adjust the turning plate fitted so that edge "a" of plate 1 (Fig. 1) and edge "b" of plate 2 (Fig. 2), respectively, are parallel to the bedplate of the sewing machine.

Tighten screw 3 (Fig. 1).

19.1 Height of the turning plates

In raised condition, plate 1 (Fig. 1) must be about 15 mm above the table top.

(The ejector slide must be able to pass below the plate).

When turning, plate 2 (Fig. 2) must not strike against workpiece retainer 5 (Fig. 3).

Loosen locknut 6 (Fig. 4) and turn knurled screw 7 according to the height required.

Tighten locknut 6 again.

Important:

When selecting the sewing programs "one-piece collar", "two-piece collar" and "cuffs", make absolutely sure the height of the turning plate is 15 mm.

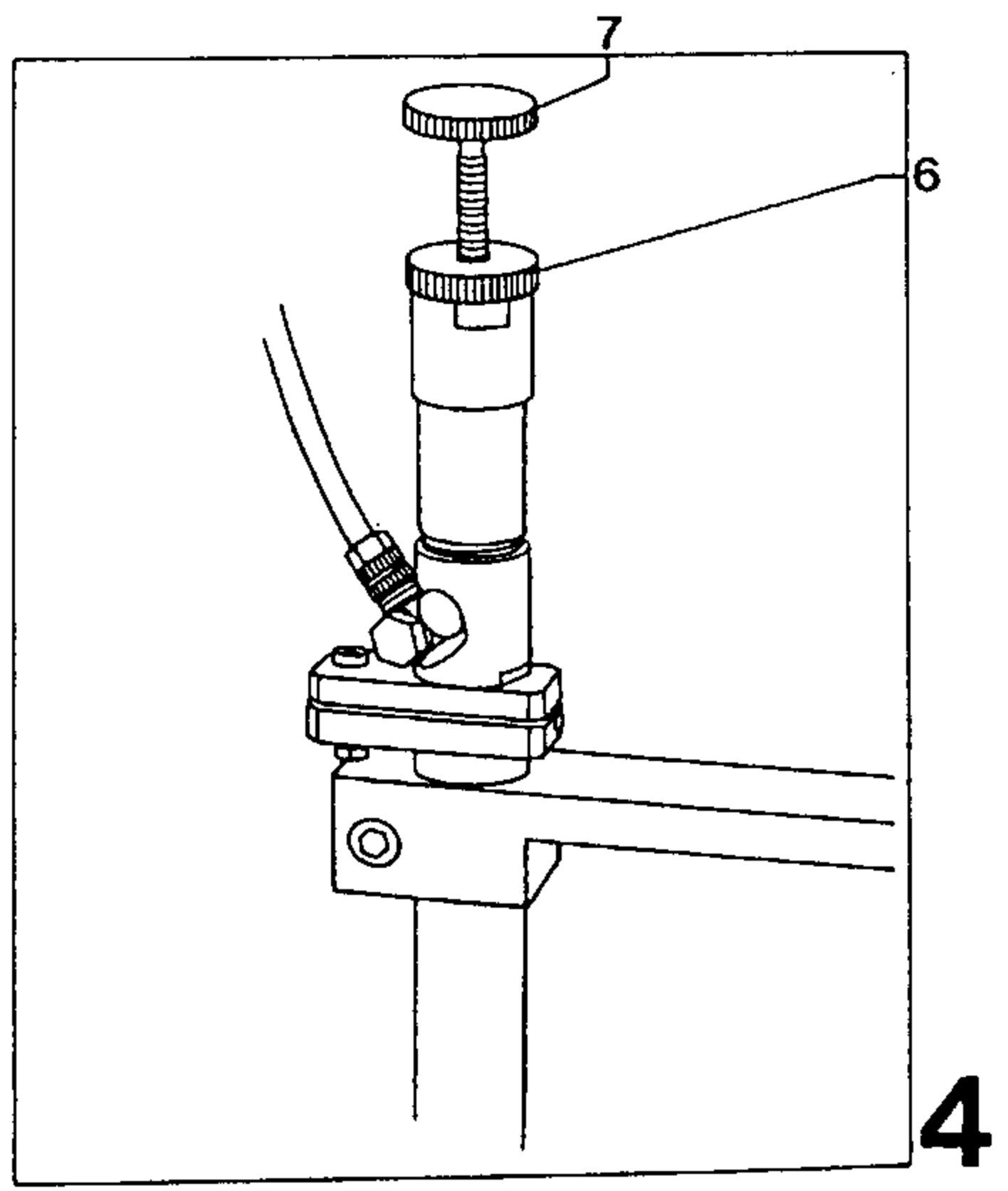
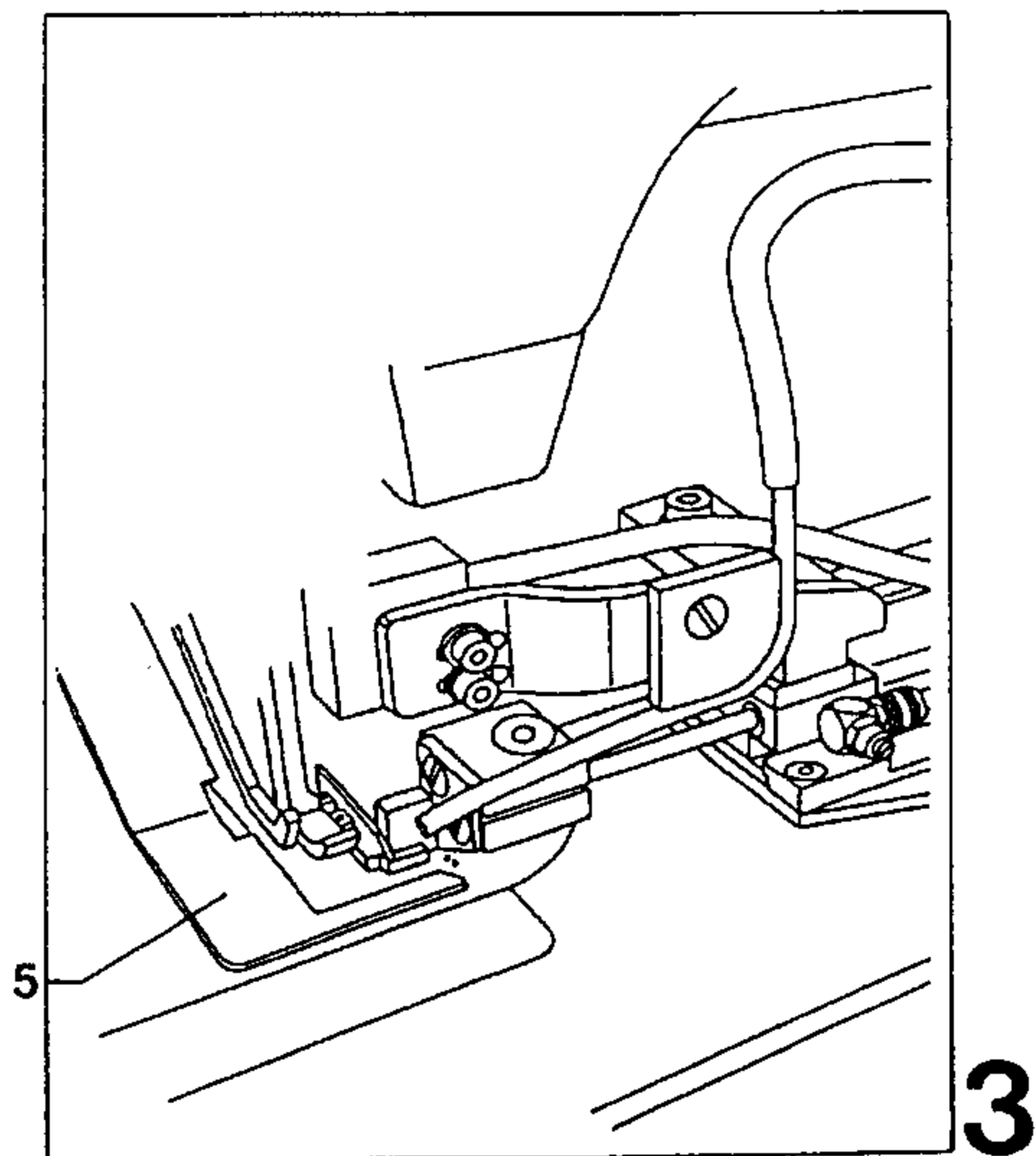
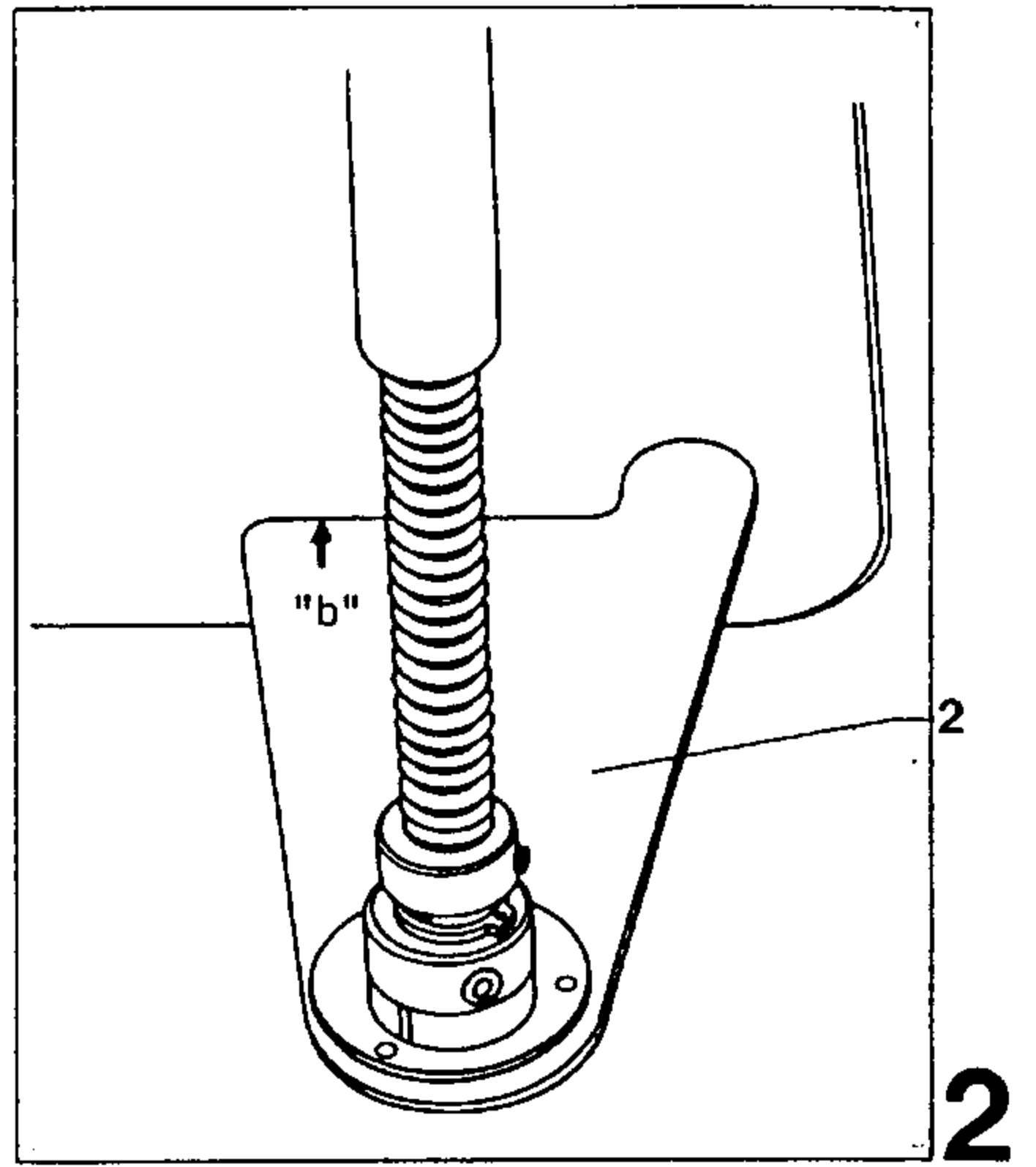
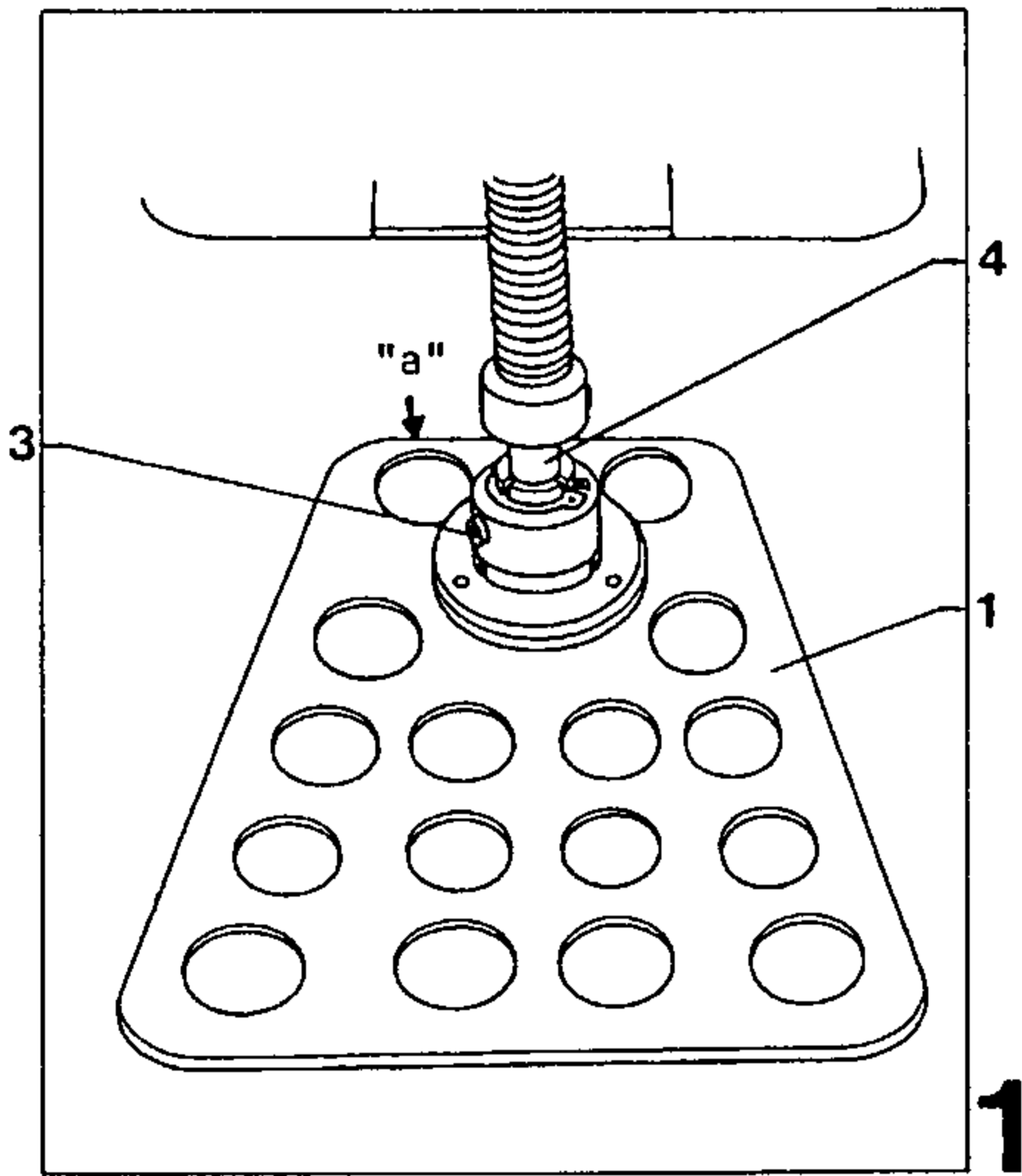

20 Stacker (only for subclasses -3/11 and -3/12)

The stacker must be adjusted so that the sewn parts are accurately stacked and do not slip off the stacker even when the stack is high.

Loosen toggle screw 1 (Fig. 1) and adjust the stacker inclination according to the stacking result.

Tighten the toggle screw again.

Important:

Always make sure pressure plate 2 (Fig. 2) is put on.

20.1 Ejector slide

Ejector 3 (Fig. 3) must be adjusted so that during its return from the stacker to ready position on the right it does not contact the workpiece, but passes by it as closely as possible.

Loosen screw 4 and adjust ejector 3 accordingly.

Tighten screws 4.

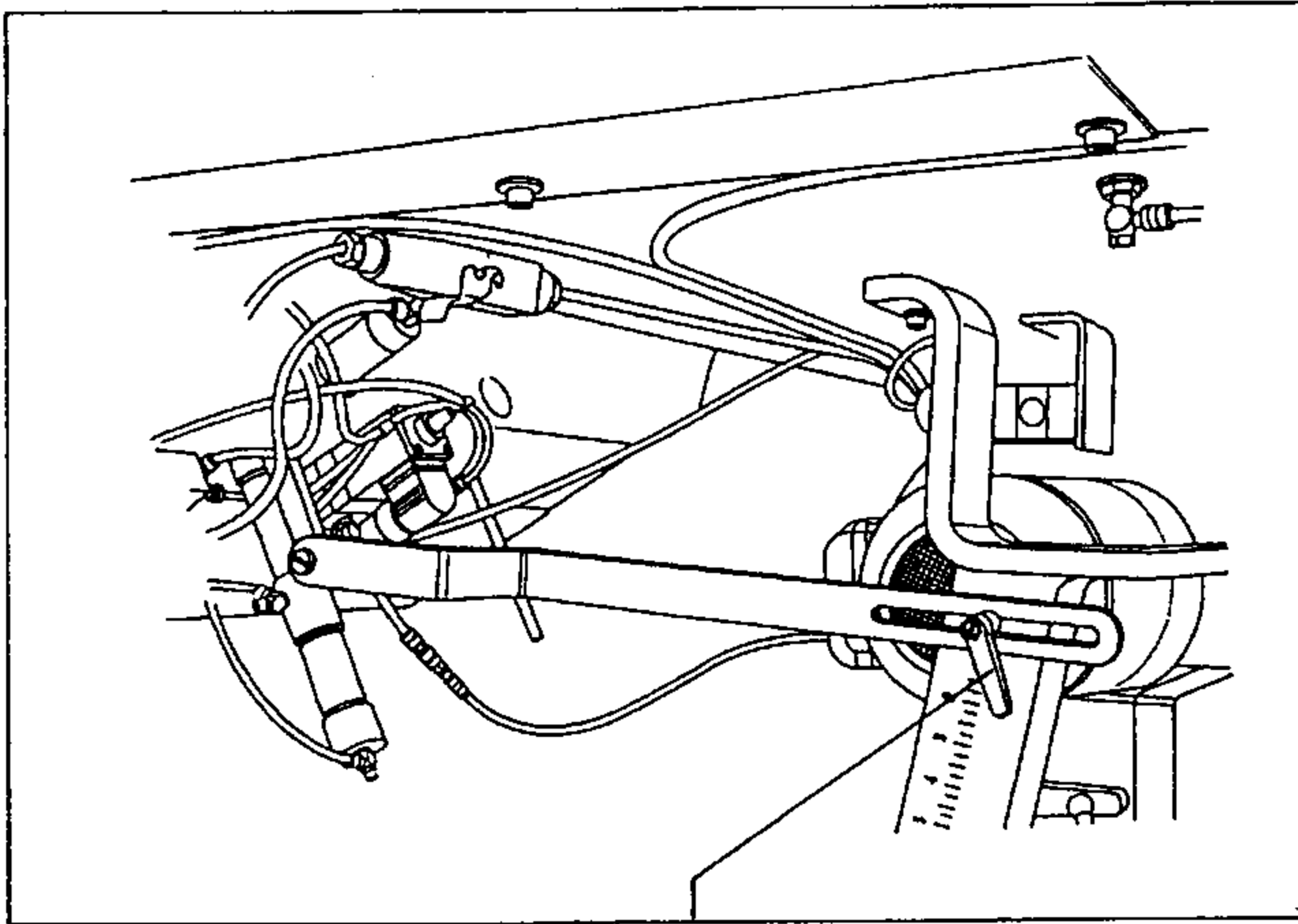

1

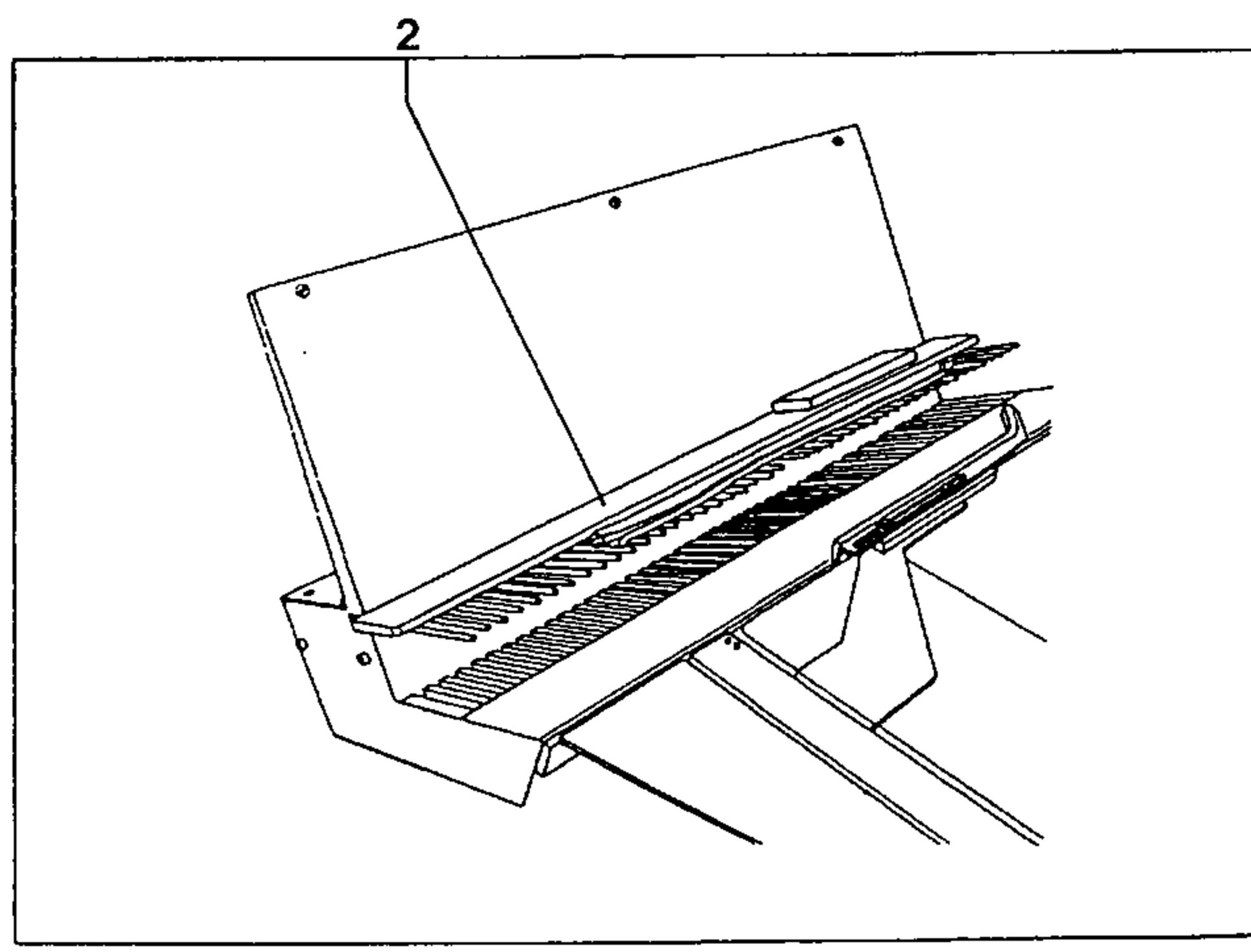

2

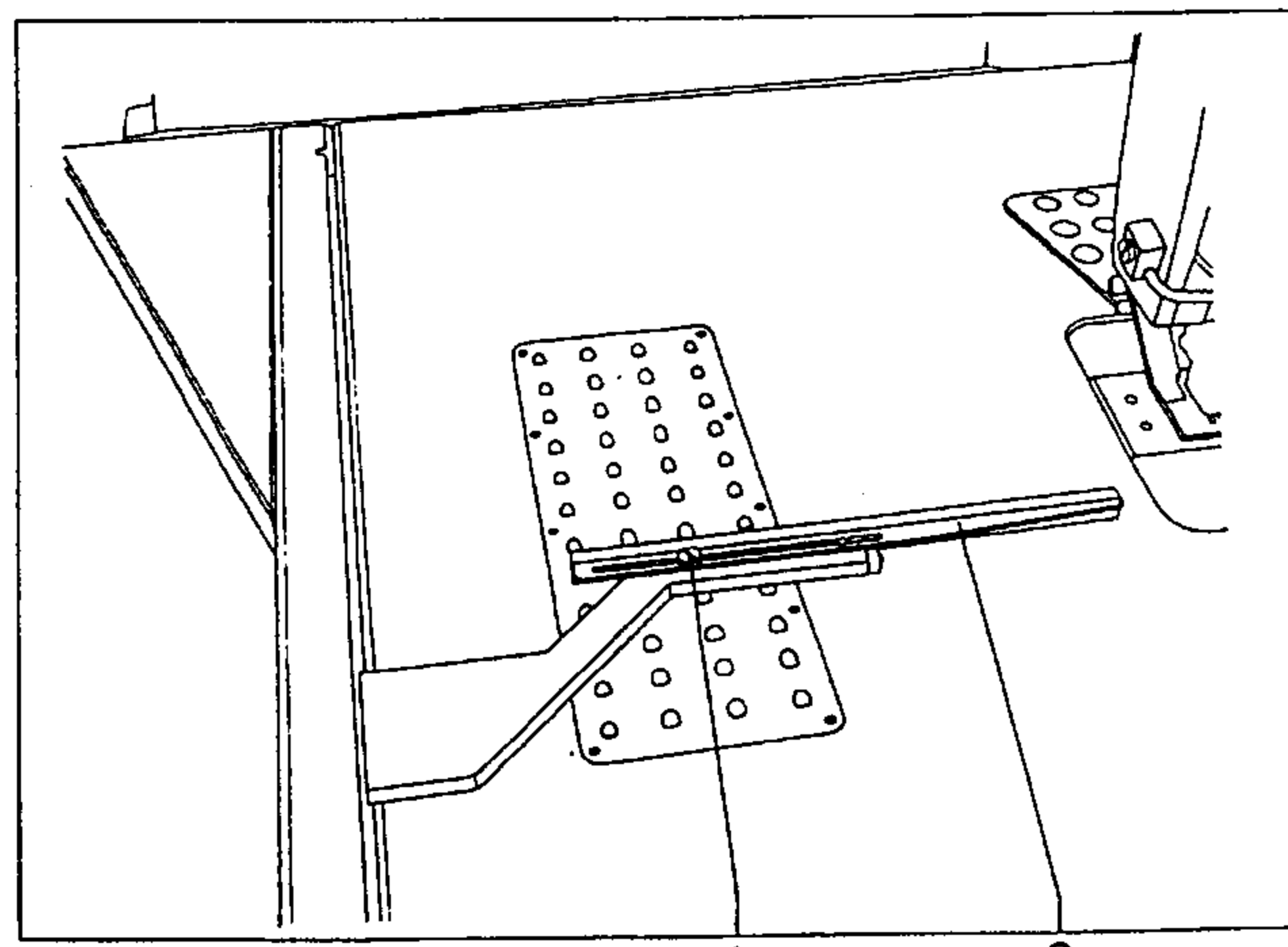

3

21 Disturbances

21.1 Thread breakage

If the thread breaks, thread monitor 1 (Fig. 1) interrupts sewing (provided the thread monitor is switched on).*

Key 2 (Fig. 2) lights up.

Remove disturbance according to section 22.

21.2 Bobbin change

At the end of the bobbin thread, the bobbin-thread-end sensor interrupts sewing.*

Key 2 (Fig. 2) lights up.

Remove disturbance according to section 22.

* Thread monitor and bobbin-thread-end sensor are only effective in long seams.

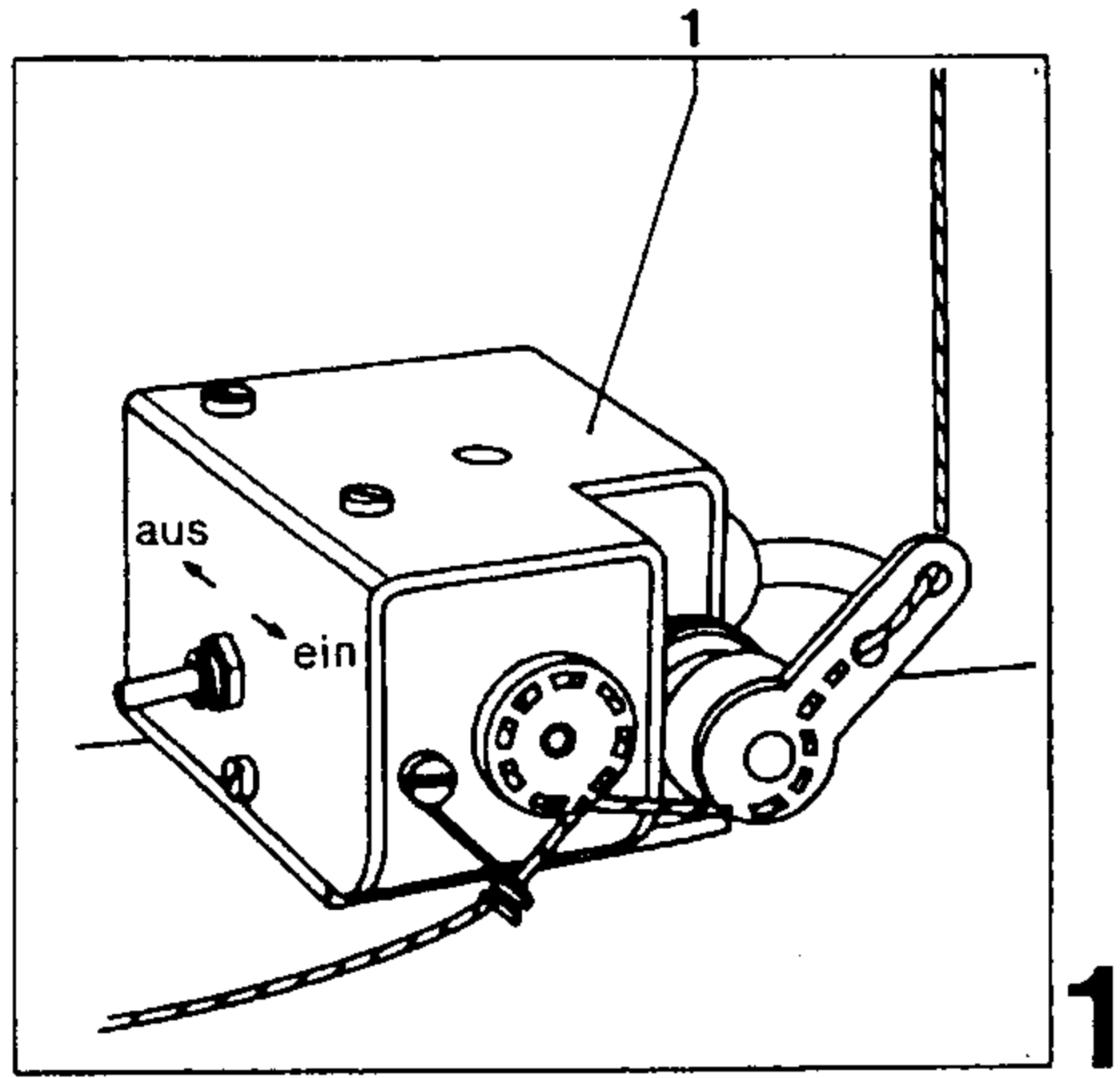

1

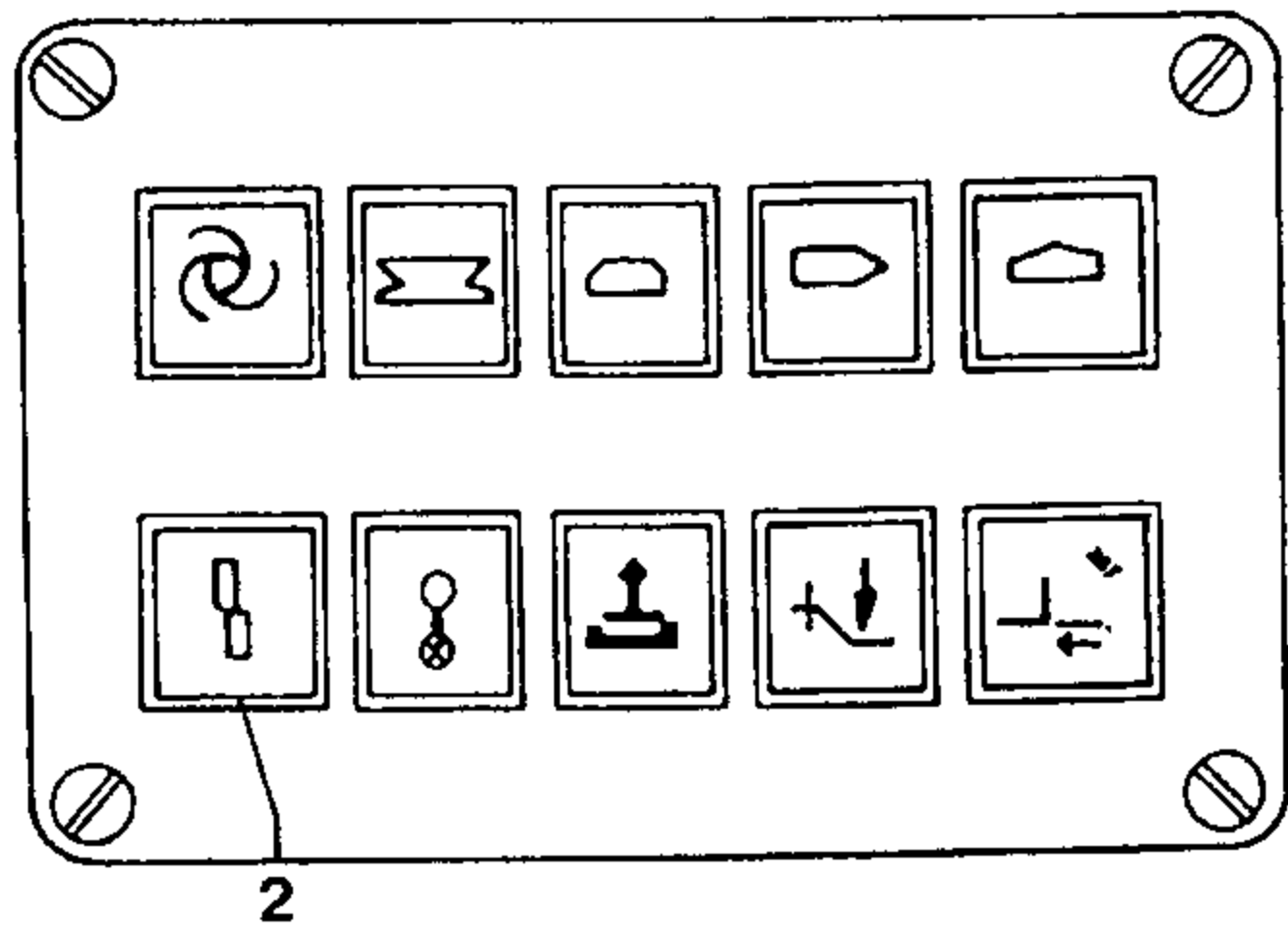

2

22 Re-sewing in case of thread breakage or bobbin change

Only the long seams of collars and cuffs can be re-sewn (seam "2" in Fig. 1 and seam "3" in Fig. 2).

There are two types of re-sewing.

22.1 Immediate re-sewing

(Further processing of part right after removal of disturbance)

Press pedal 1 (Fig. 3) backwards to position "4" and hold it there,

- presser foot is raised,
- needle goes to "up"-position.

Remove workpiece from the machine.

Release pedal to position "1",

- presser foot is lowered.

Thread the machine according to Section 9 or change the bobbin according to Sections 5 to 8.

Press key 2 (Fig. 4)

- key goes out,
- presser foot is raised.

Insert the workpiece so that the seam overlaps by about 2 stitches at the joint.

Press key 3 (Fig. 5),

- sewing operation runs off.

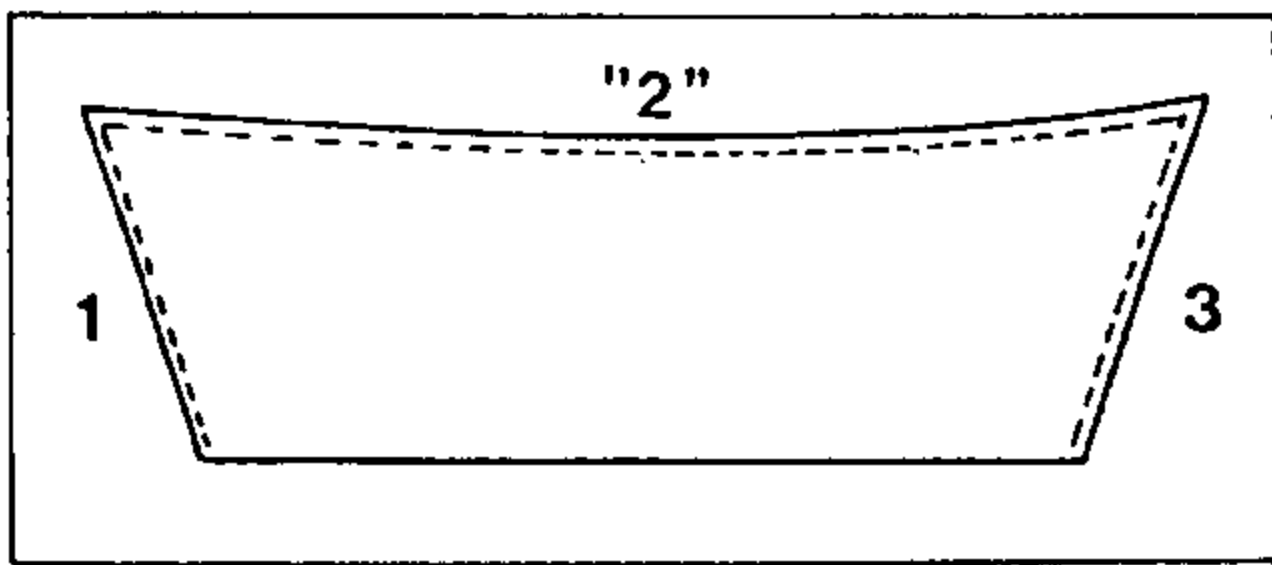

1

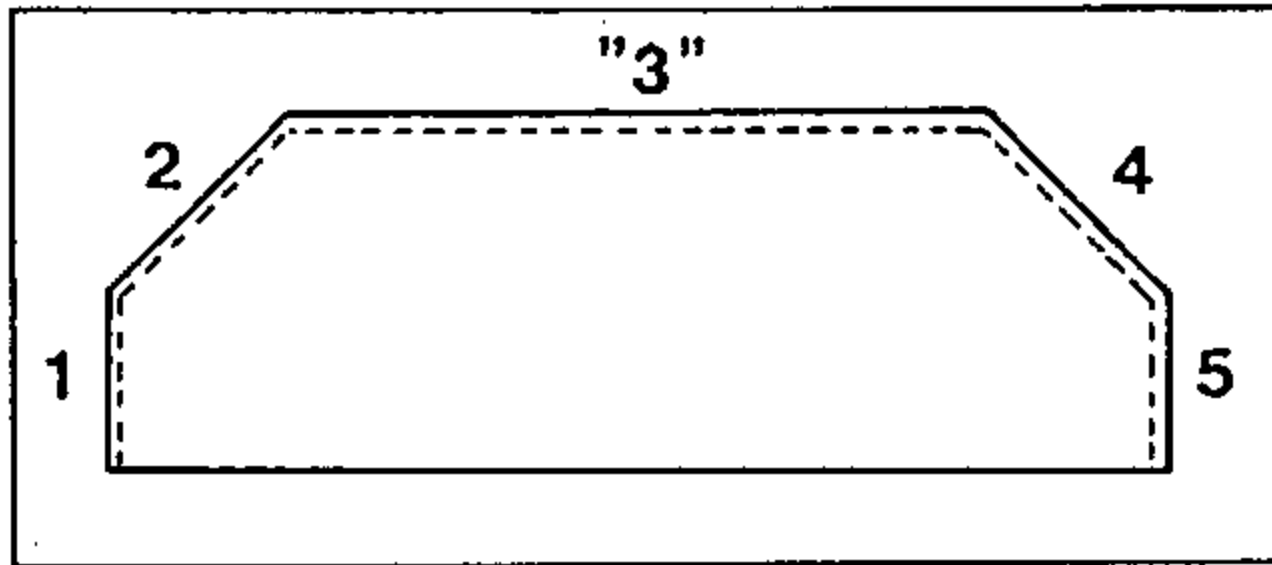

2

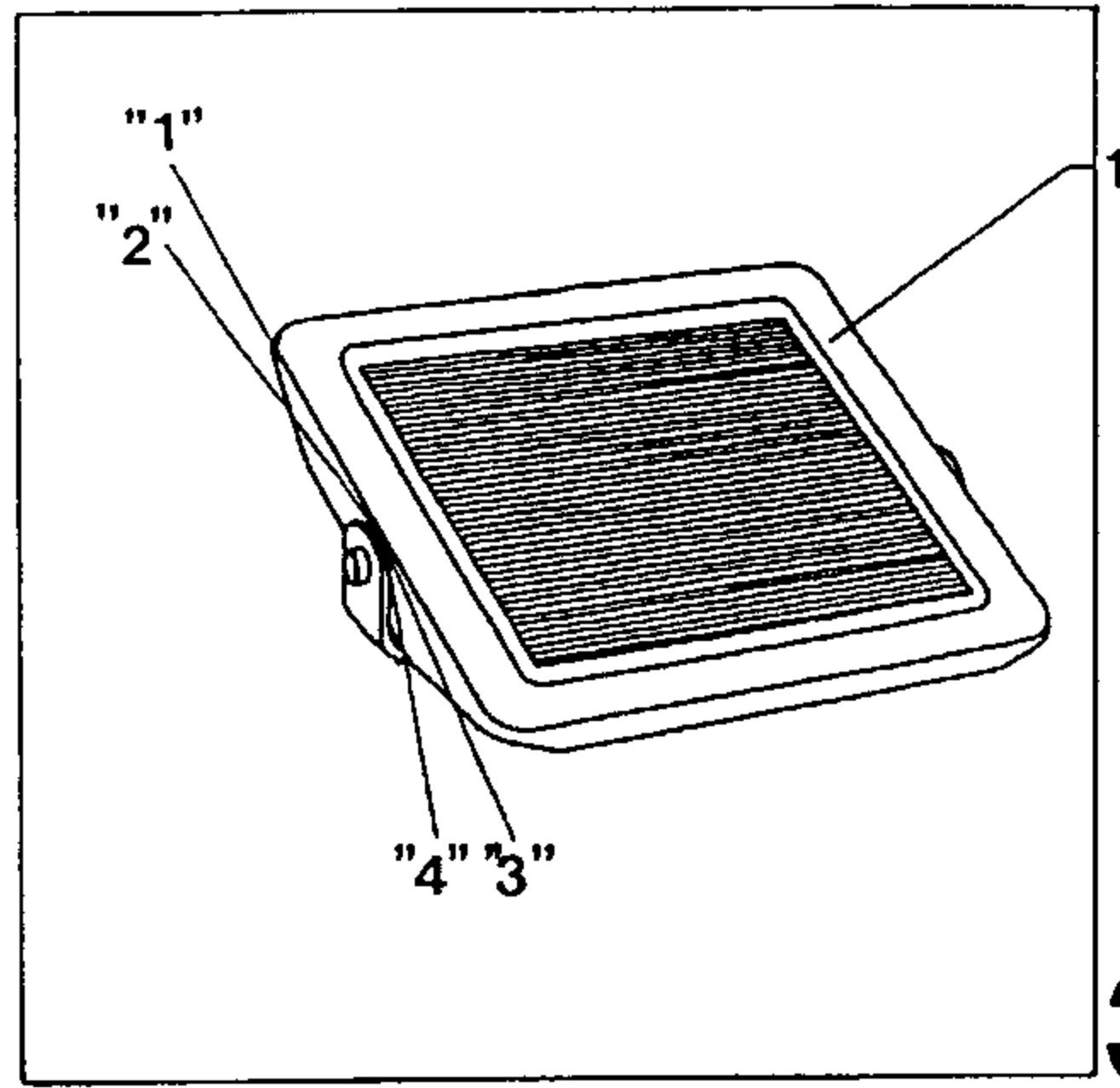

3

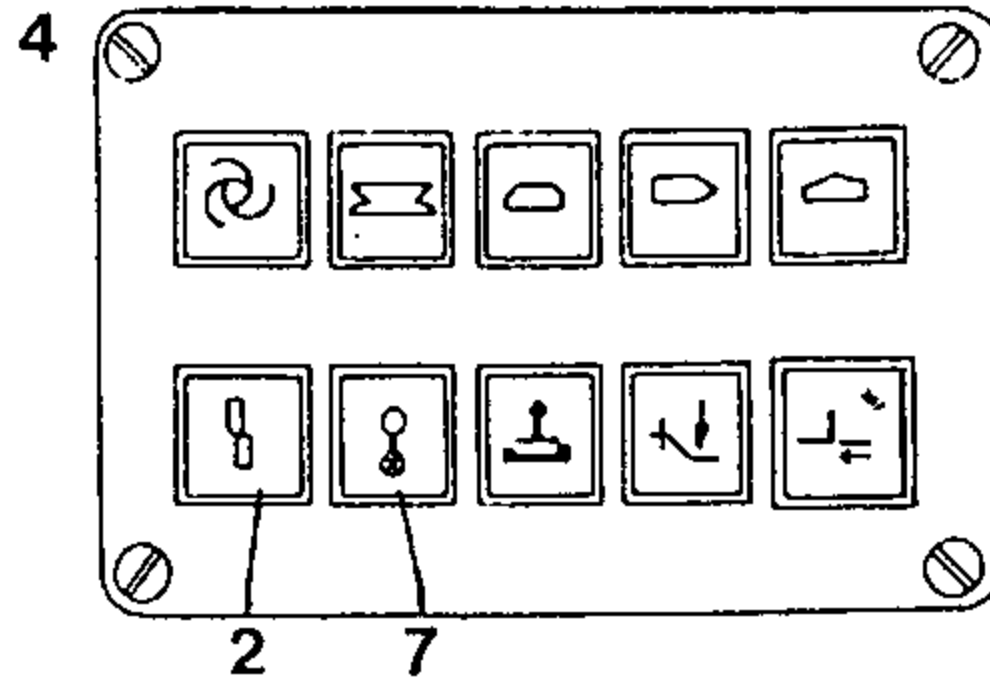
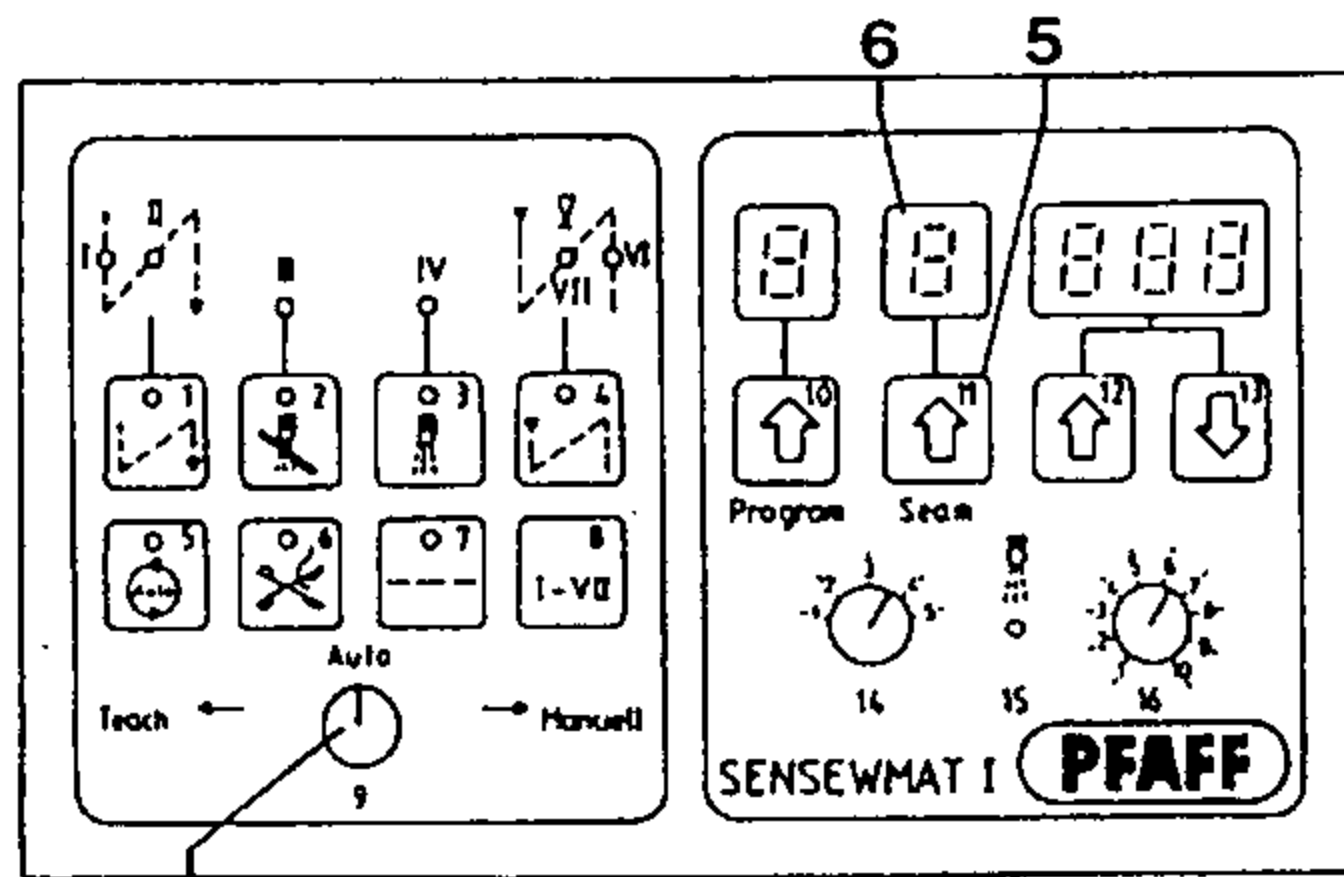

4

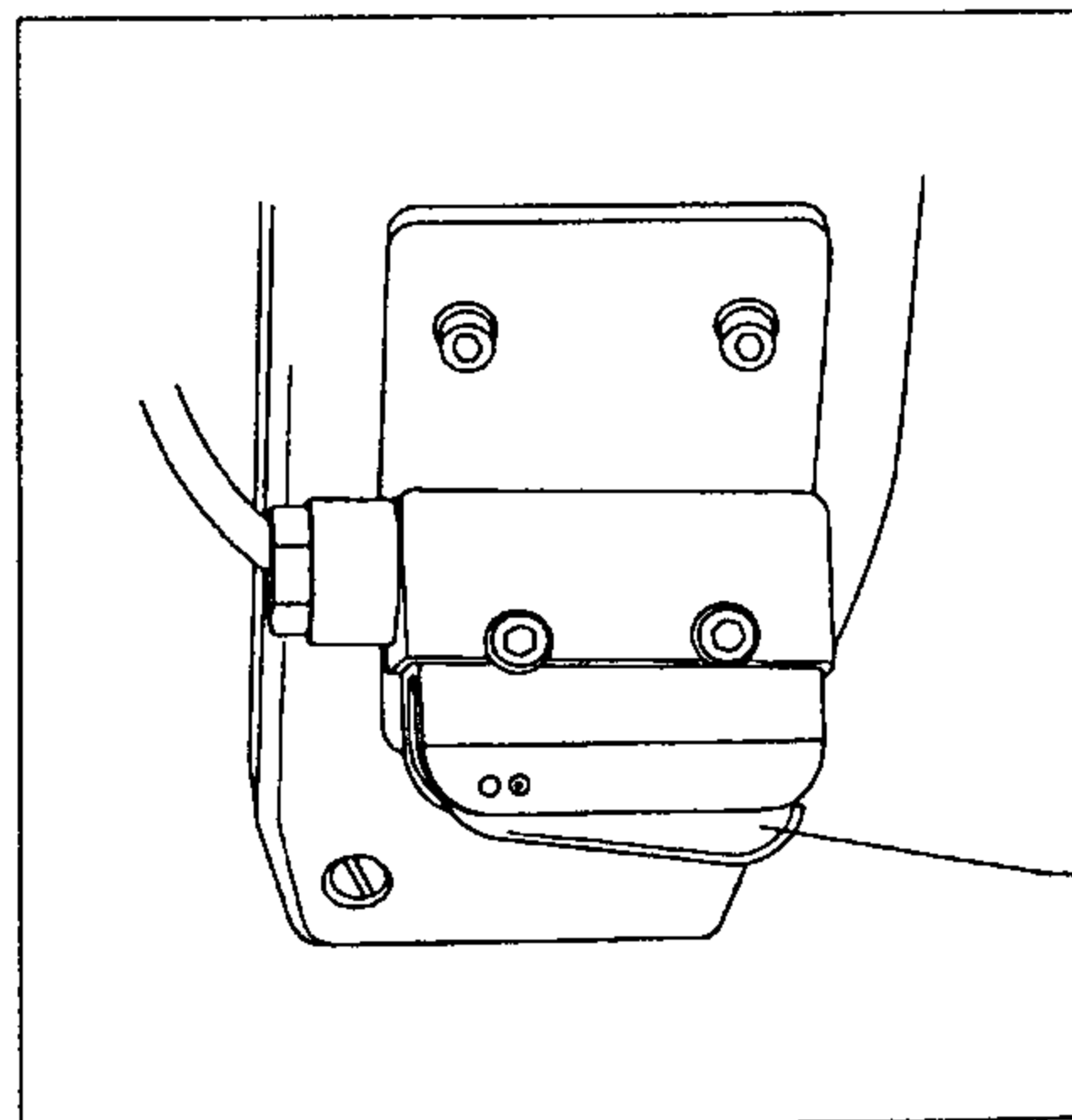

5

22.2 Subsequent re-sewing

(Part is removed after disturbance and is finished later on)

Set rotary switch 4 (Fig. 6) at "TEACH".

Press key 5 "SEAM" repeatedly until display 6 shows

- "2" in collar program,
- "3" in cuff program.

Set rotary switch 4 (Fig. 6) at "AUTO".

Press key 7,

- keys 7 and 2 are lit,
- presser foot and workpiece retainer are lowered,
- fabric guide moves forward.

Insert the workpiece in such a way that the seam overlaps by about 2 stitches at the joint.

Press key 3 (Fig. 7),

- key 7 goes out,
- sewing operation runs off.

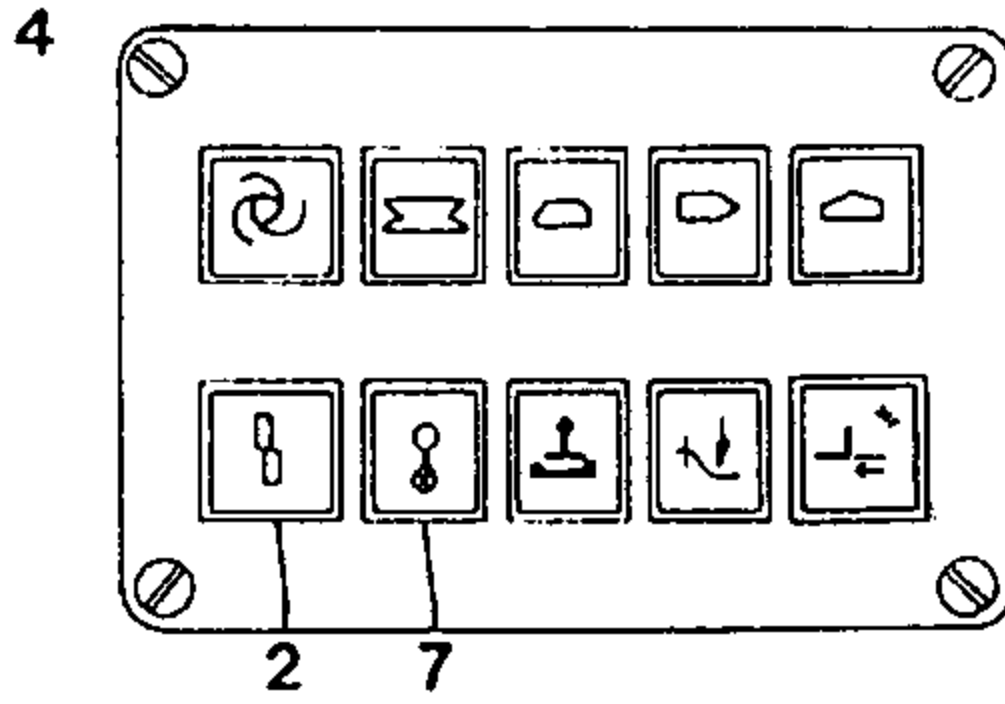
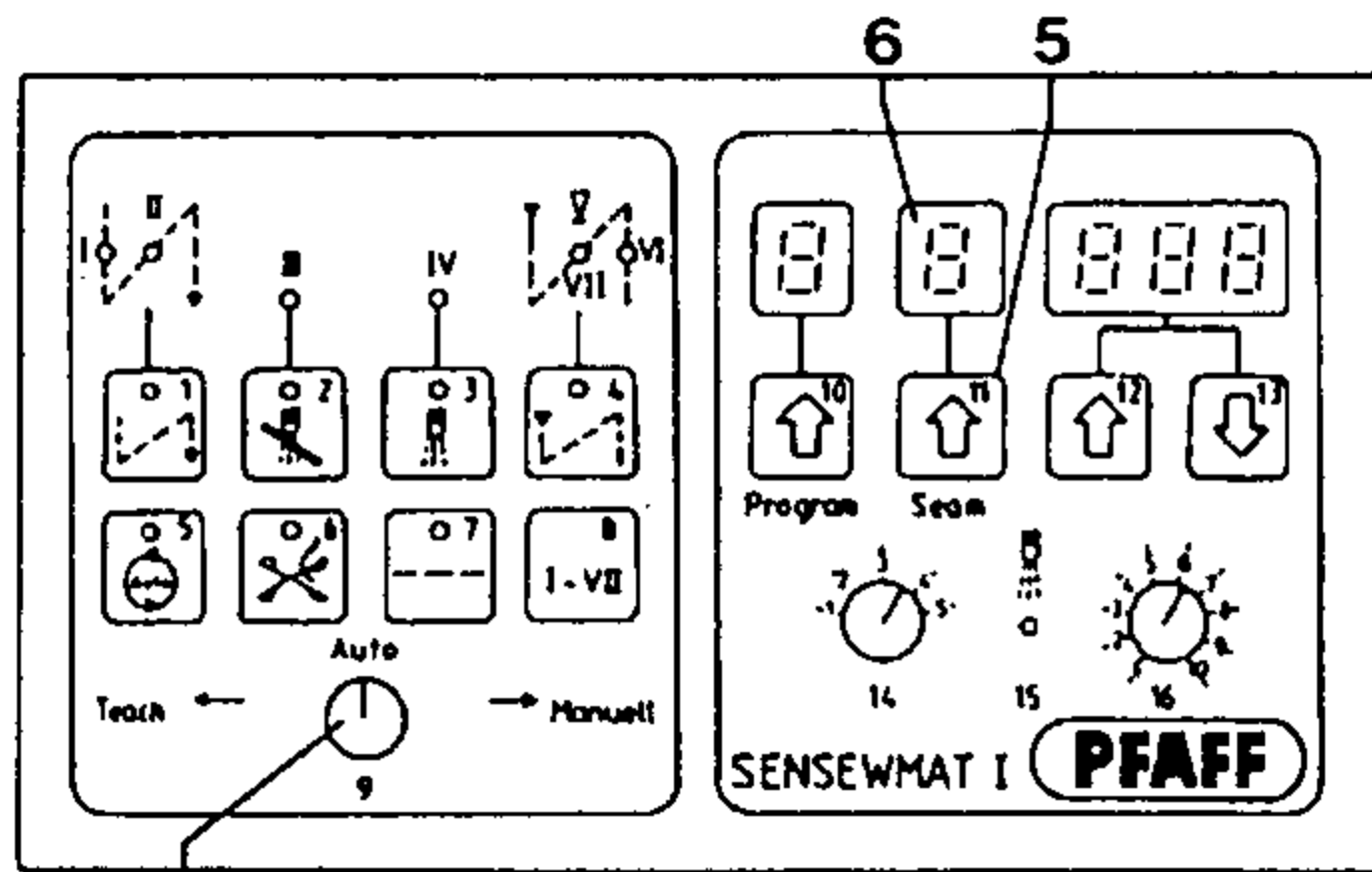

6

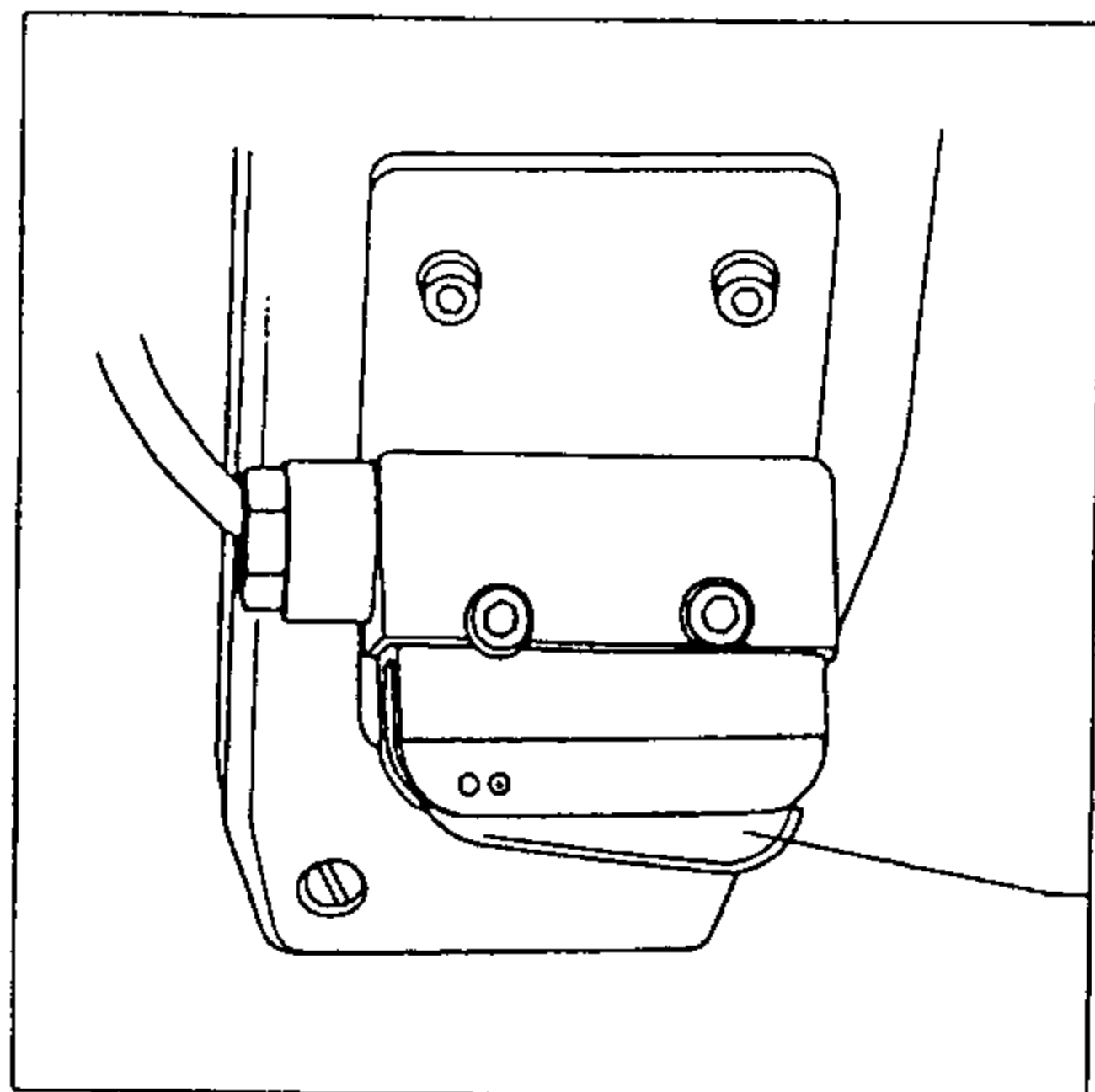

3

7

23. Air jet selection (only on subclasses -3/02 and -3/12)

Depending on the workpiece characteristics, there may be deviations from the stitching path at the end of seam when processing one-piece collars (Fig. 1).

This deviation can be prevented by feed-assisting air blast.

For air flow regulation, it is possible to switch on or off air jets 1 (Fig. 2) in rows at switches 2 (Fig. 3).

Adjust the intensity of the air flow at flow control valve 3.

23.1 Air jet at the sewing head

The sewn collars or cuffs must be in a position parallel to the ejector slide before they are stacked. This ensures accurate stacking.

Regulate the air flow at flow control valve 4 (Fig. 4).

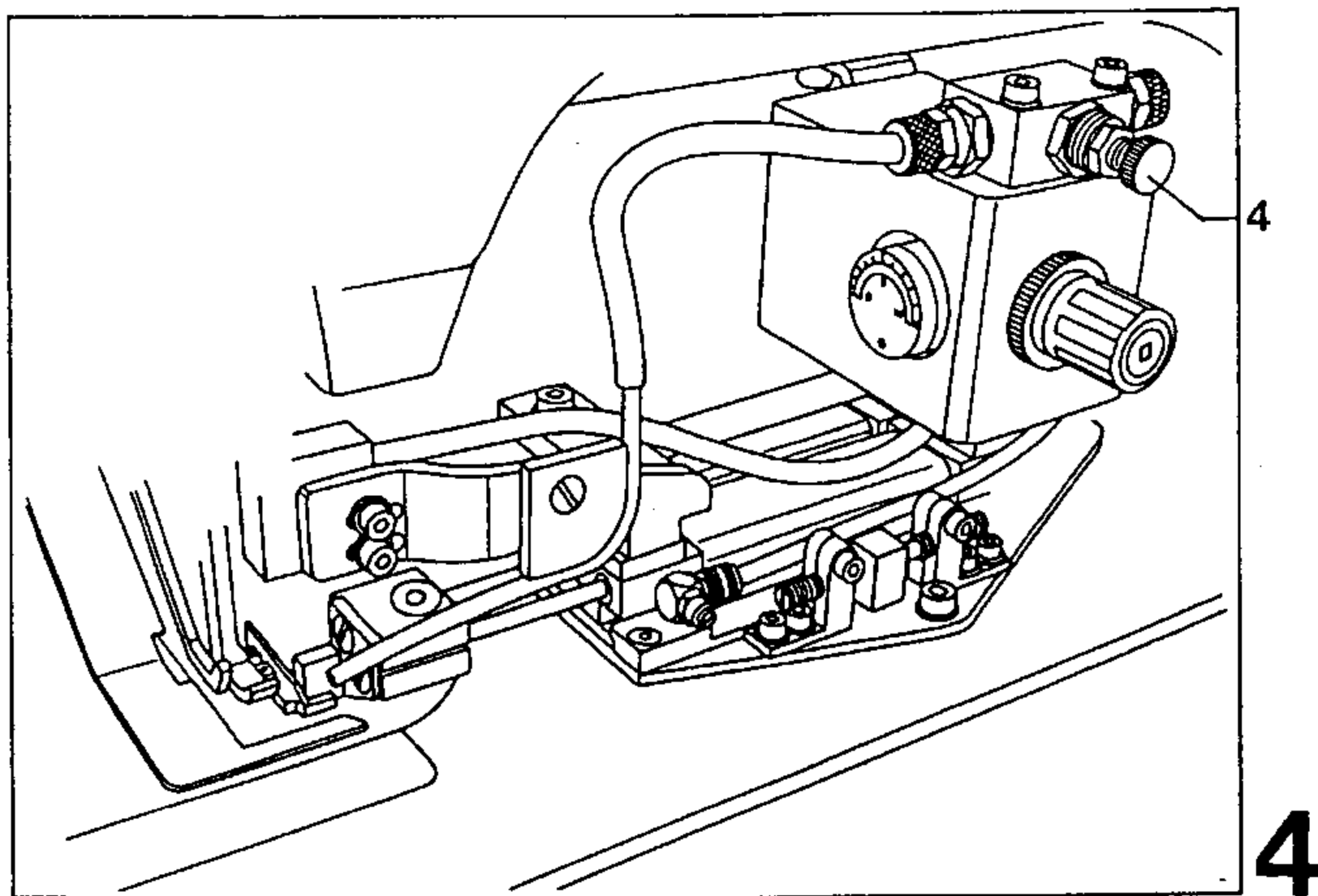
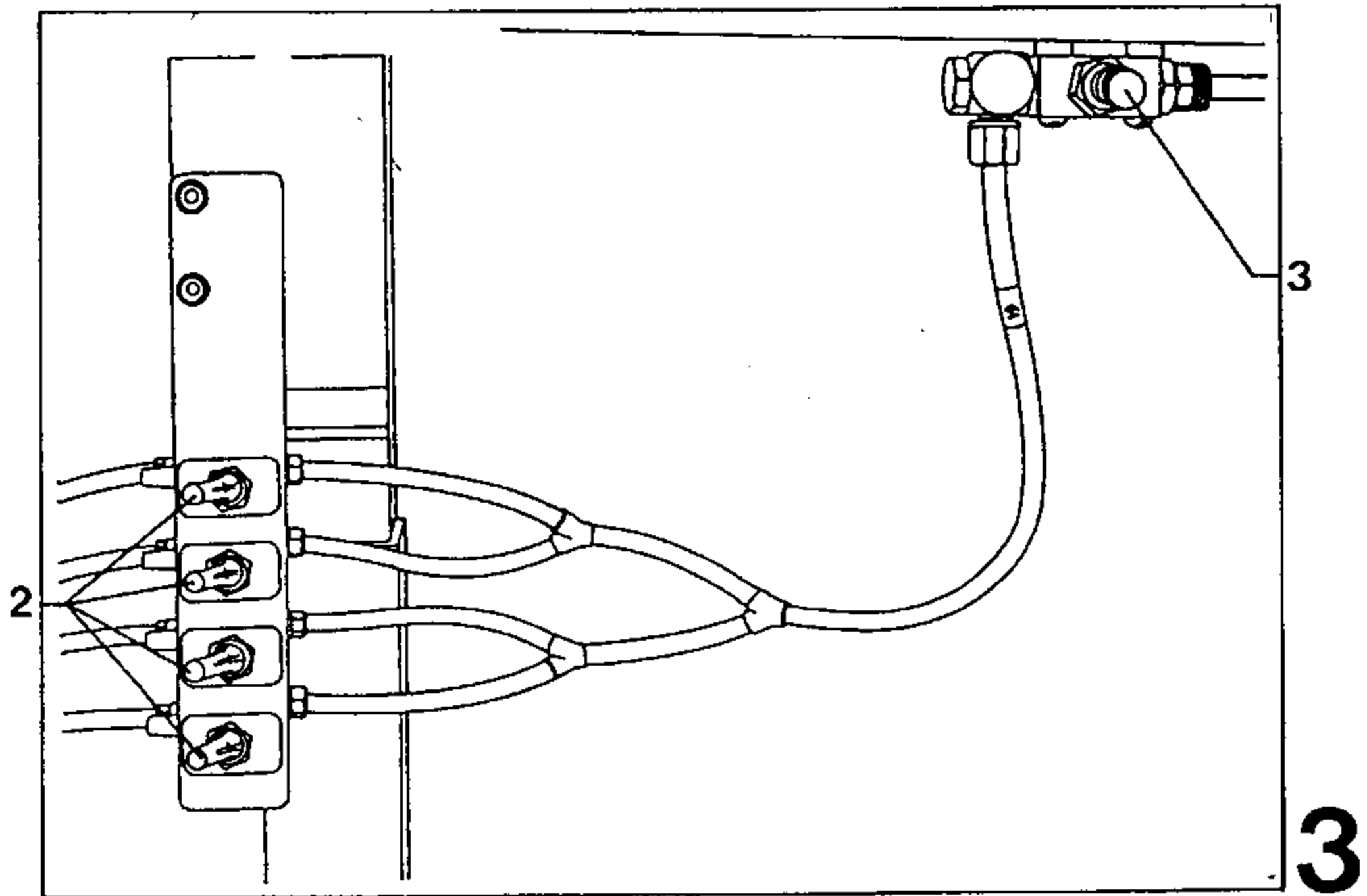
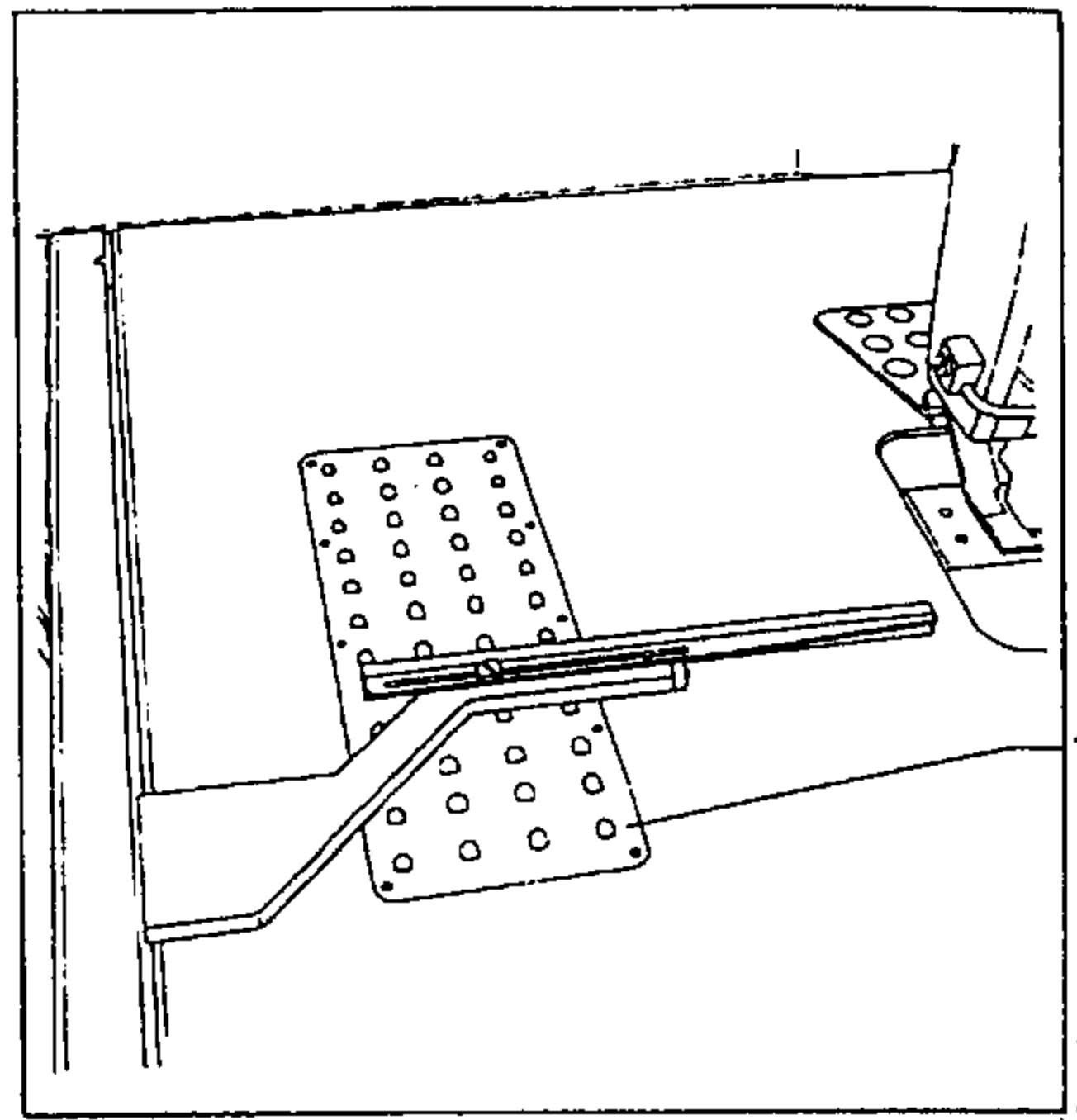
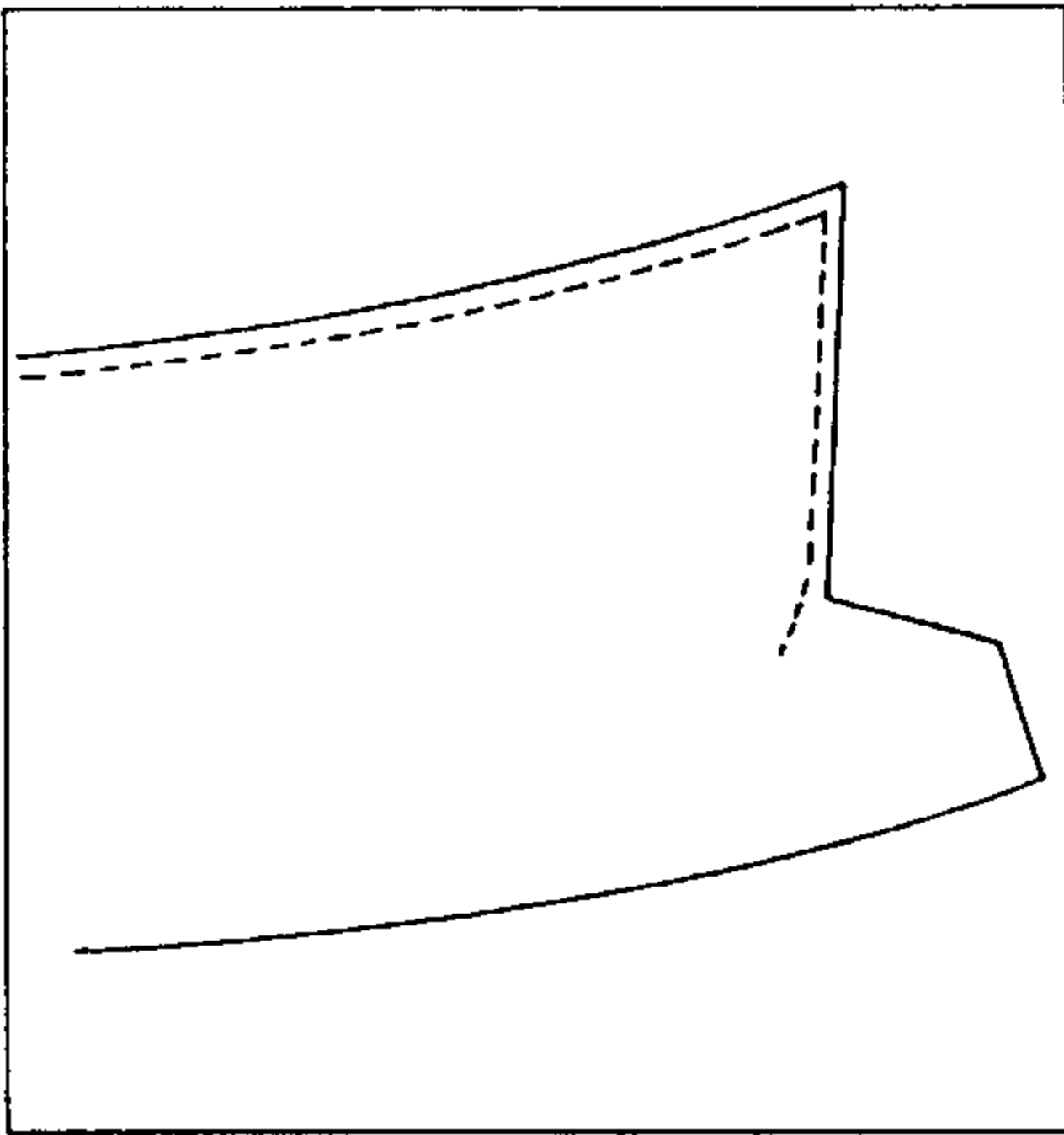

24 Switching off the machine

Press the red button of the master switch **1** (Fig. 1).

Turn off the compressed air valve at the main supply.

25 Care and maintenance

25.1 Air filter/lubricator

If the machine is in constant use, check the air filter/lubricator (Fig. 2) daily.

The oil level must not be allowed to drop below the mark (see arrow) on oil bowl **2**. (If necessary ask the mechanic to top up the oil).

The water level must not be allowed to pass the mark (see arrow) on bowl **3**. To drain off the water, open drain screw **4**. After draining, close drain screw **4** again.

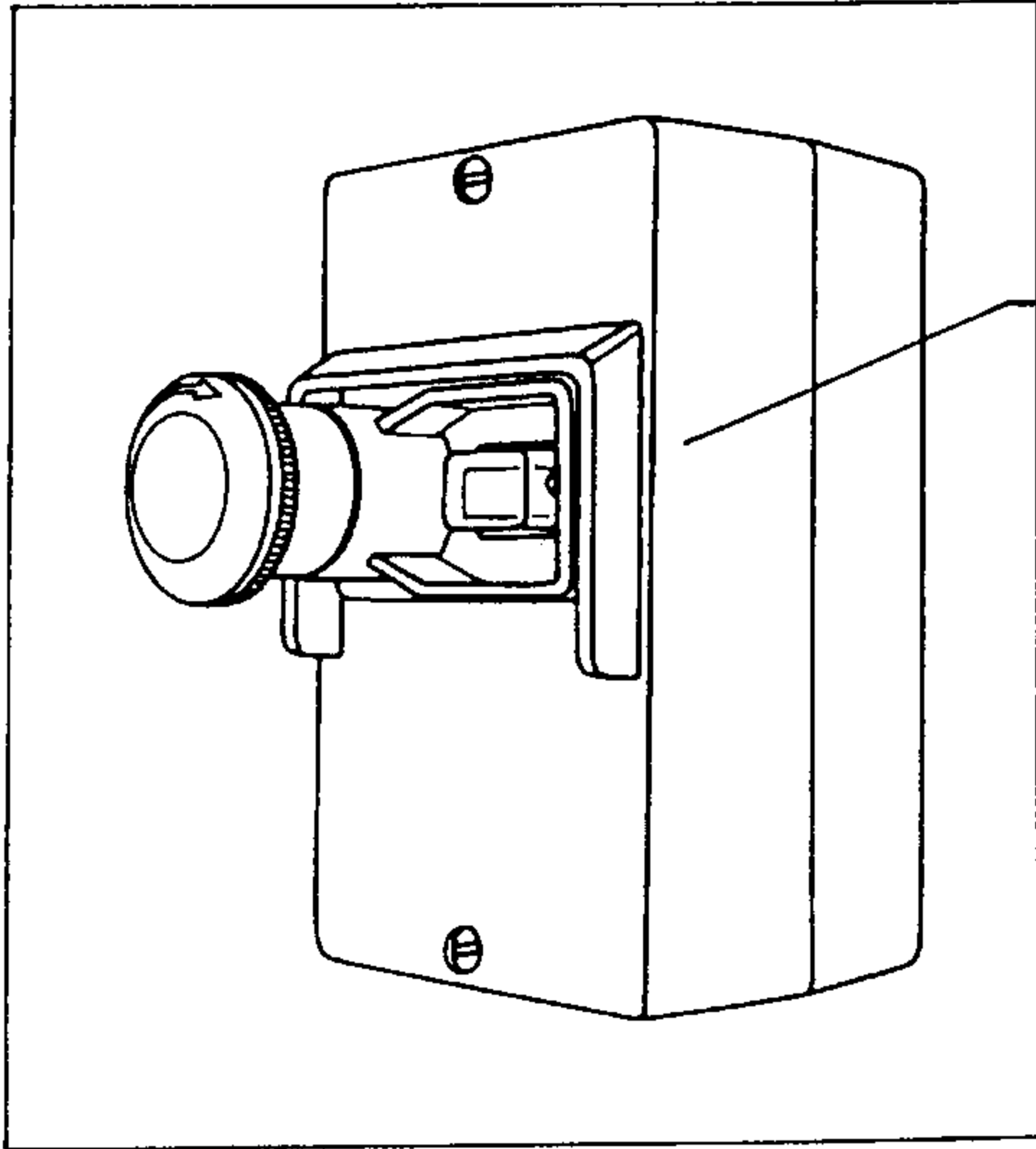

1

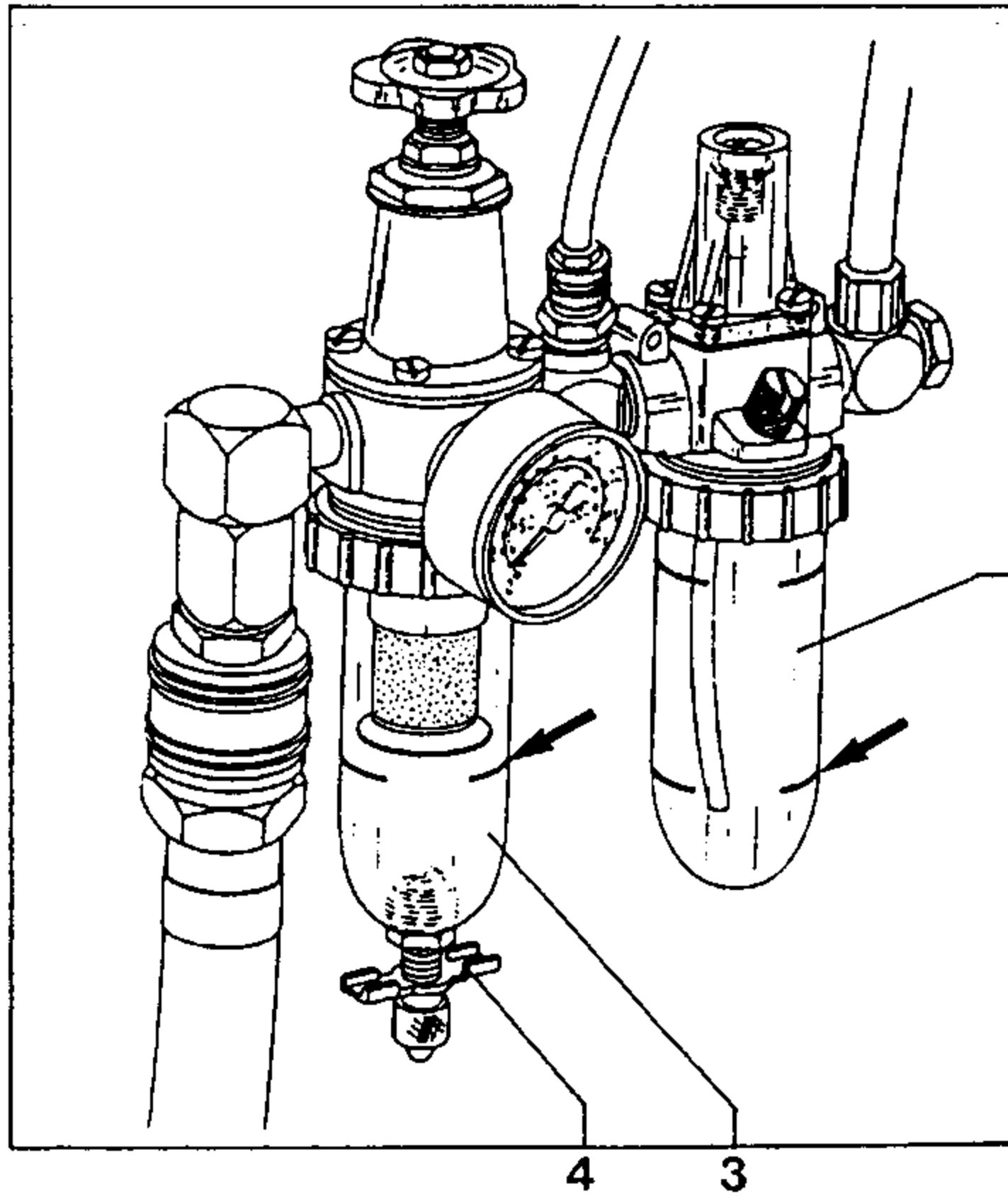

2

4 3

25.2 Oiling the sewing machine

If the machine is in constant use, check the oil level in oil sight-glass 5 (Fig. 3) daily.

The oil level must not be allowed to drop below mark 6. If necessary, top up oil through the hole (see arrow).

We recommend Pfaff oil No. 280-1-120 144 or an oil with a mean viscosity of $22 \text{ mm}^2/\text{sec.}$ at 40° C and a density of 0.865 g/cm^3 .

25.3 Cleaning the machine

Clean the entire machine regularly.

Clean the sewing hook area daily.

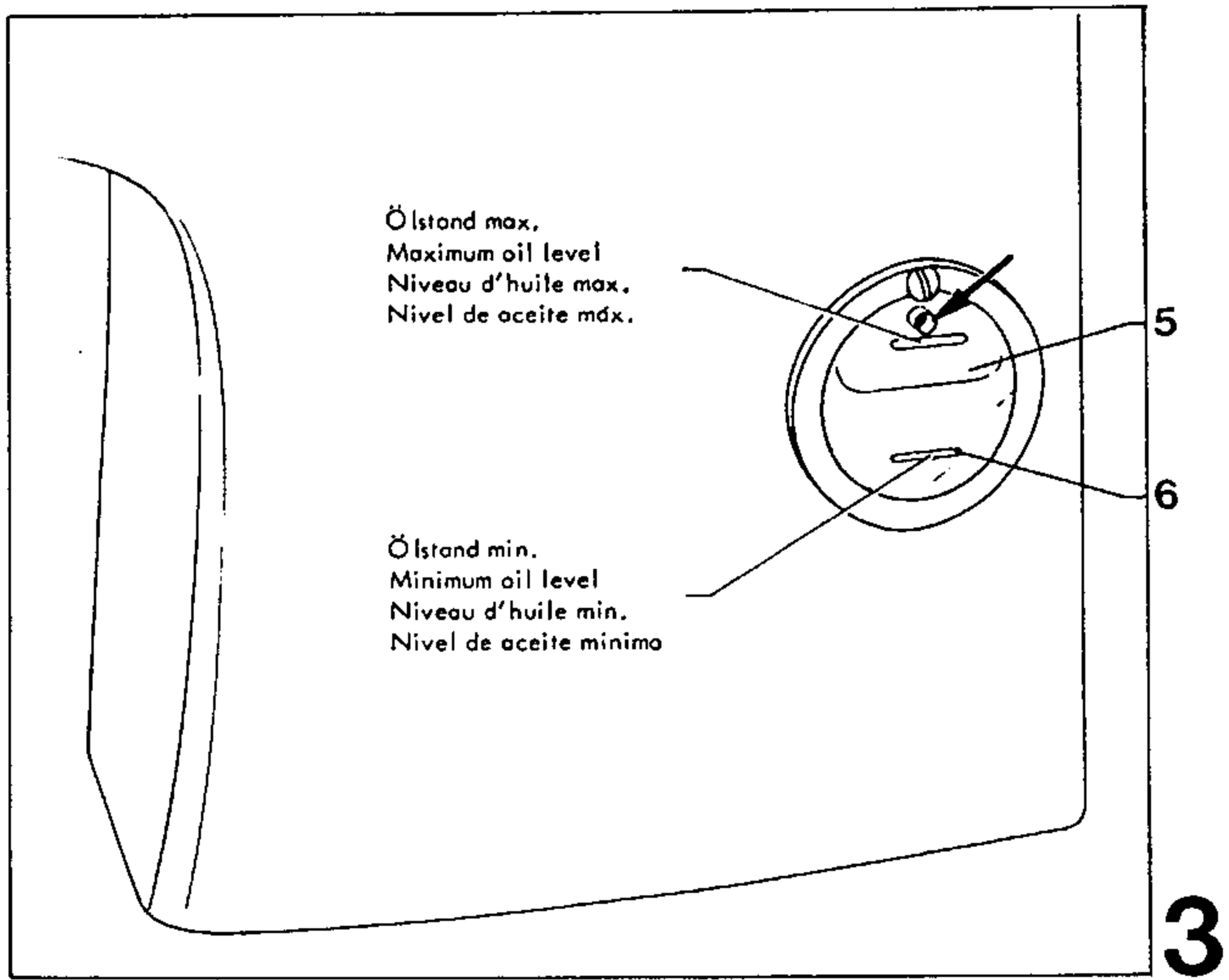

PFAFF

PFAFF
Postfach 3020
D-67653 Kaiserslautern

Telefon: (0631) 200-0
Telefax: (0631) 17202
Telex: 45 753

Gedruckt in der BRD
Printed in Germany
Imprimé en R.F.A.
Impreso en la R.F.A.
Stampato in R.F.G.
отпечатано ФРГ