

PFAFF

3557

Service Manual

-3/01

-3/11

-3/02

-3/12

For adjustments to the Sensewmat use the instruction and service manual "SENSEWMAT I".

For adjustments to the thread trimmer, use Service Manual -900/51 for series 480 machines

Notes on safety

- The machine must only be commissioned in full knowledge of the instruction book and operated by persons with appropriate training.
- The machine must only be used for the purpose intended.
- Use of the machine without the safety devices belonging to it is not permitted.
- When gauge part are exchanged (e.g. needle, presser foot, needle plate, feed dog and bobbin) during threading, when the workplace is left, and during service work, the machine must be isolated from the mains by switching off the main switch or disconnecting the mains plug.
On mechanically operated clutch motors without start inhibitor it is necessary to wait until the motor has stopped.
- General servicing work must only be carried out by appropriately trained persons.
- Repairs, conversion and special maintenance work must only be carried out by technicians or persons with appropriate training.
- For service or repair work on pneumatic systems the machine must be isolated from the compressed air supply system.
Exceptions to this are only adjustments and function checks made by appropriately trained technicians.
- Work on the electrical equipment must only be carried out by electrical engineers or appropriately trained persons.
- Work on parts and systems under electric current is not permitted, except as specified in regulations DIN 57105 or VDE 0105.
- Conversions or changes to the machine must be authorized by us and only be made on adherence to all safety regulations.
- For repairs, only replacement parts approved by us must be used.



This symbol draws attention to special danger of injury.

It is imperative to read and adhere to these notes and all generally applicable safety regulations.

Contents

	For safety instructions, see inside front cover
	Tools, gauges, and other aids for adjustment
	Control elements
1	Setting the machine up
1.1	Conversion from lateral operation to front operation
2	Connection of power and compressed air
3	Checks
3.1	Air filter/lubricator
3.2	Sewing machine
3.3	Direction of rotation
3.4	Hook lubrication
4	Preparatory work for adjusting the sewing machine
4.1	Tilting the sewing machine over
4.2	Removal of the sewing machine
4.3	Blocking the sewing machine at different adjustment positions
4.4	Adjustment holes
5	Position of needle in needle hole
6	Neutralizing the bottom feed
7	Bottom feed advancing motion
8	Bottom feed lifting motion
9	Fabric clearance
10	Top feed driving- and connecting lever
11	Neutralizing the top feed
12	Automatic backtacking mechanism
13	Top feed advancing motion
14	Top feed lifting motion
15	Top feed lift
16	Position of vibrating presser
17	Synchronisation of top- and bottom feed
18	Synchronisation of top- and bottom feed in reverse sewing
18.1	Limitation of feed regulator for backtacking
18.2	Limitation of feed regulator for stitch condensation
19	Stitch length adaption
20	Eccentric hook shaft bearing
21	Needle height, needle rise and hook to needle clearance
22	Eccentric bearing of bobbin case opener shaft
23	Bobbin case opener position
24	Bobbin case opener movement
25	Oil tube in oil thrower
26	Oil check valve
27	Needle thread tension release
28	Thread check spring and thread regulator
29	Bobbin winder
30	Pressure of vibrating presser and presser foot
31	Stitch length limitation
32	Automatic presser foot lift
33	Proximity switch of automatic presser foot lift
34	Proximity switch of thread trimmer
35	Take-up lever (removal and fitting)
36	Fitting the sewing machine
37	Turning head
38	Photocell
39	Proximity switches for turning head limitation
40	Potentiometers in the control box
41	Work on the air filter/lubricator

**For the following adjustments, please use the instruction- and service manual for Sen-
sewmat I.**

Bottom feed dog height
Torsion spring for feed dropping lever
Feed dropping linkage lever
Feed dropping depth
Feed dropping cylinder
Distance between vibrating presser lifting lever and actuating lever
Stroke limitation of vibrating presser lifting cylinder
Light emitter for needle plate
Setting the motor speeds
Synchronizer

Tools, gauges, and other equipment needed for adjustment

Set of screwdriver with blades from 2 to 10 mm wide
Set of open-ended wrenches
Set of open-ended wrenches with openings from 7 to 14 mm
Socket wrench, 22 mm
Allen keys from 1.5 to 6 mm
Metal rule
Adjustment pin (5 mm $_$), part No. 13-030 341-05
Adjustment gauge, part No. 61-111 642-19 or 08-880 179-00
Adjustment link, part No. 91- 069 375-15
(gauge foot, part No. 61-111 639-20)
Packet of needles (system 134 KK)
Strip of white paper, sewing thread and testing material
Circuit tester

CONTROL ELEMENTS

master switch

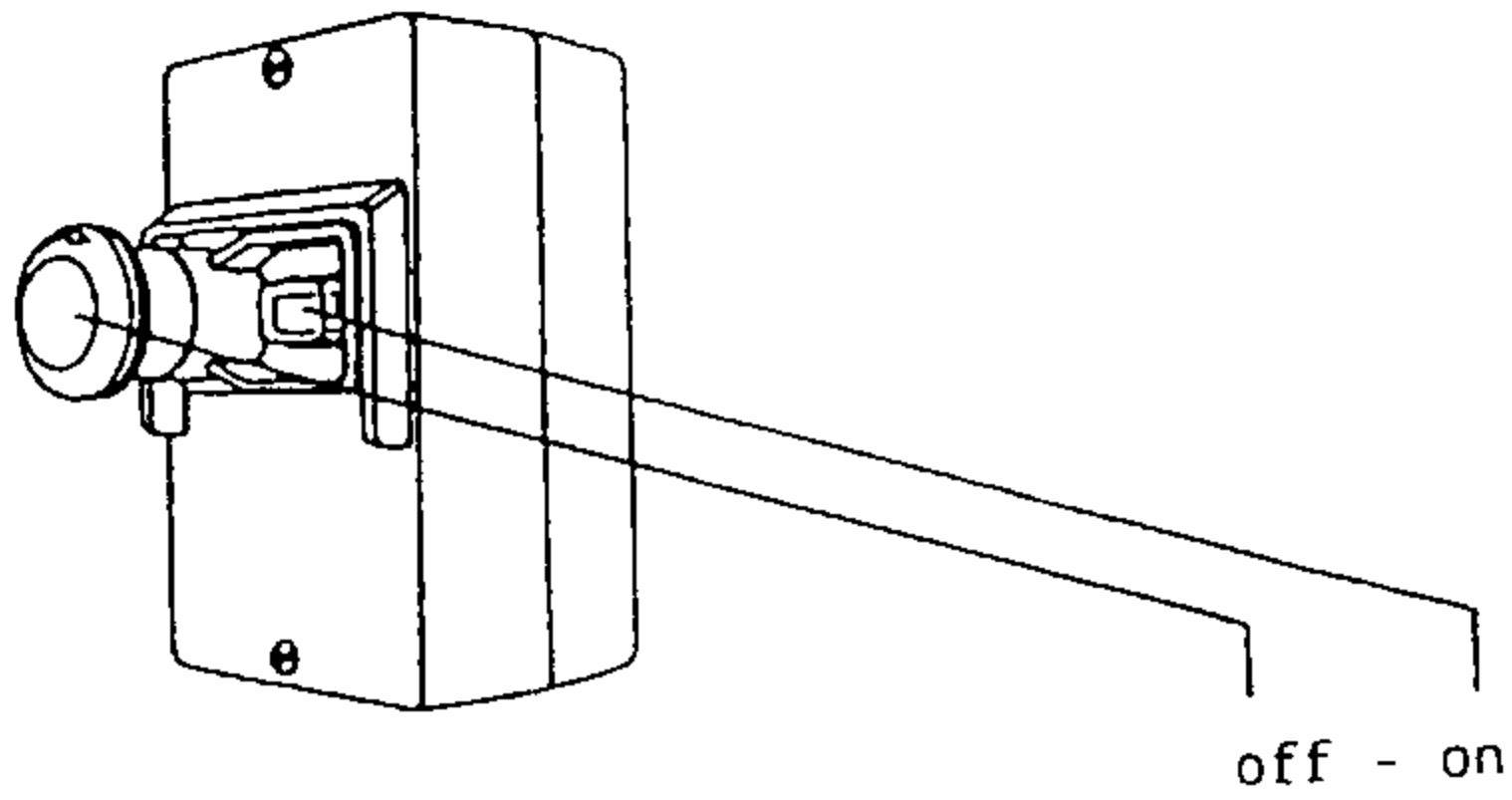

pedal

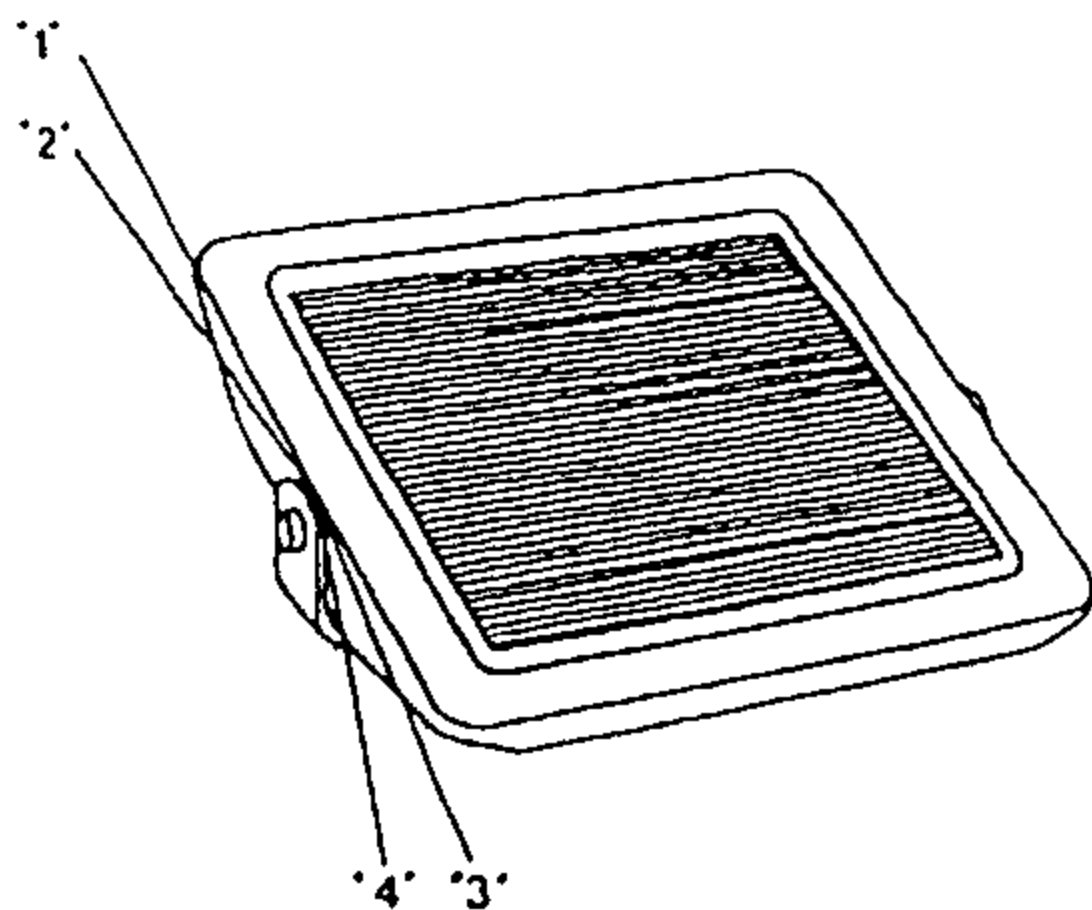

program start

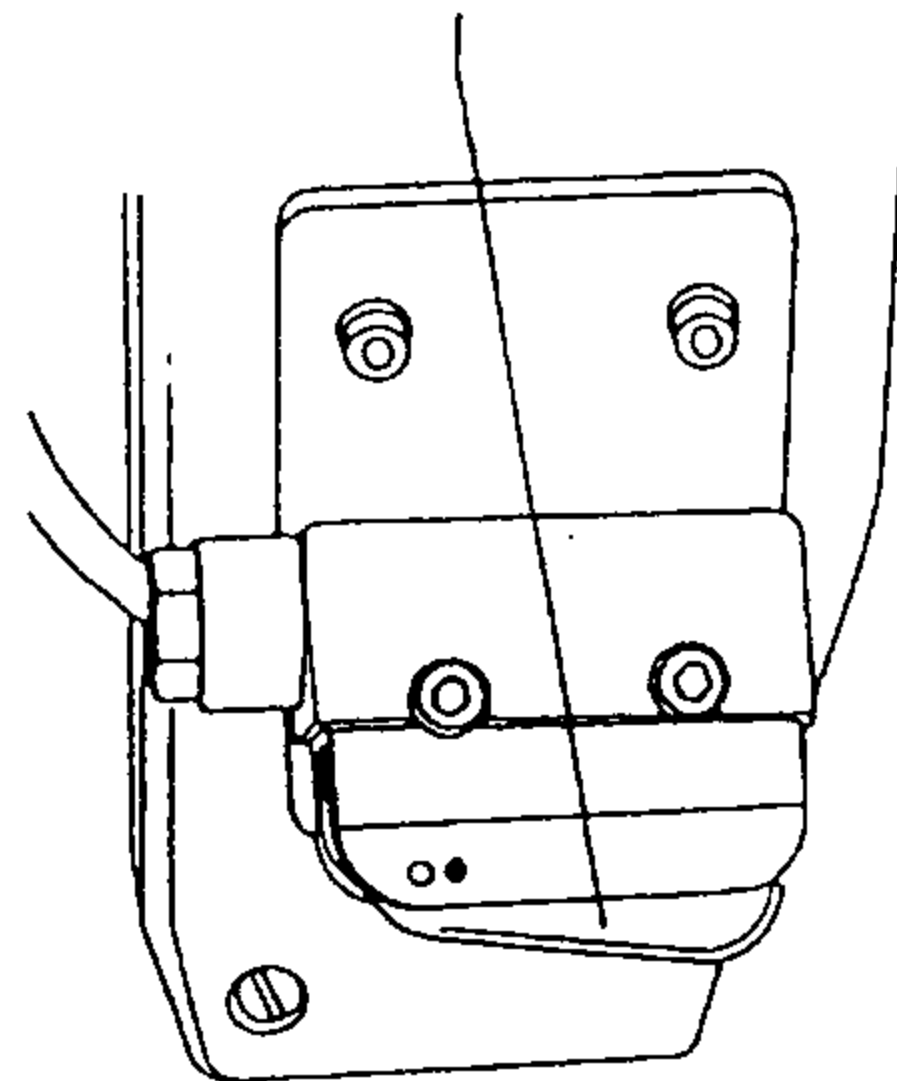

"1" - rest position

"2" - sewing
- without program at Sensemat switch position "Manual"
- with the Sensemat program selected at Sensemat switch position "Auto"

"3" - presser foot up

"4" - presser foot up, thread trimming

thread monitor

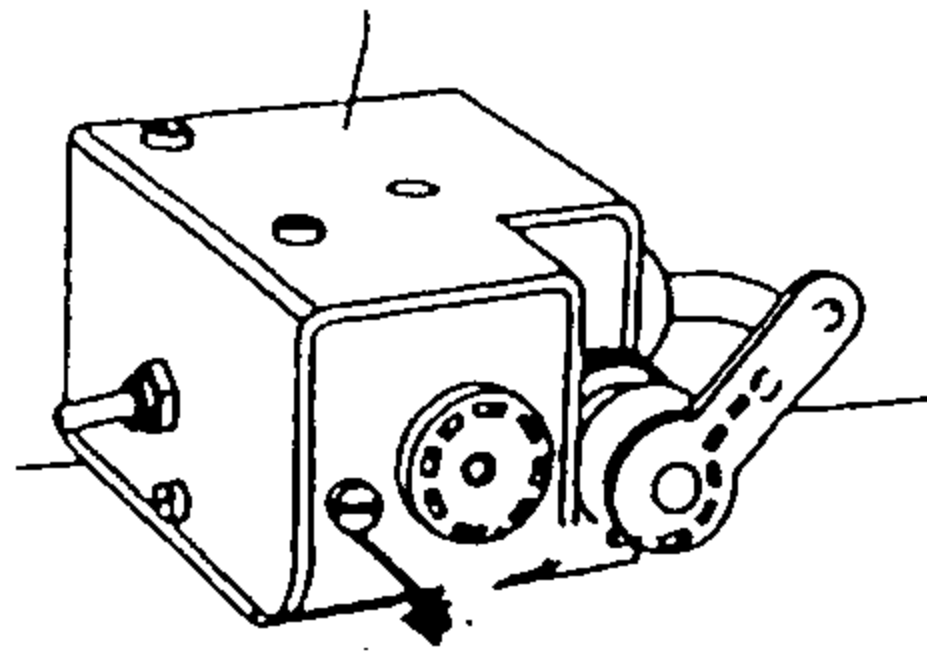

piece counter

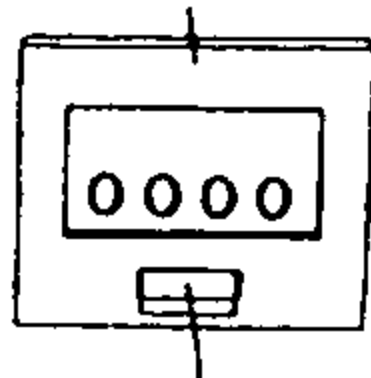

reset button

For explanation of control panel, see instruction- and service manual for Sensemat 1

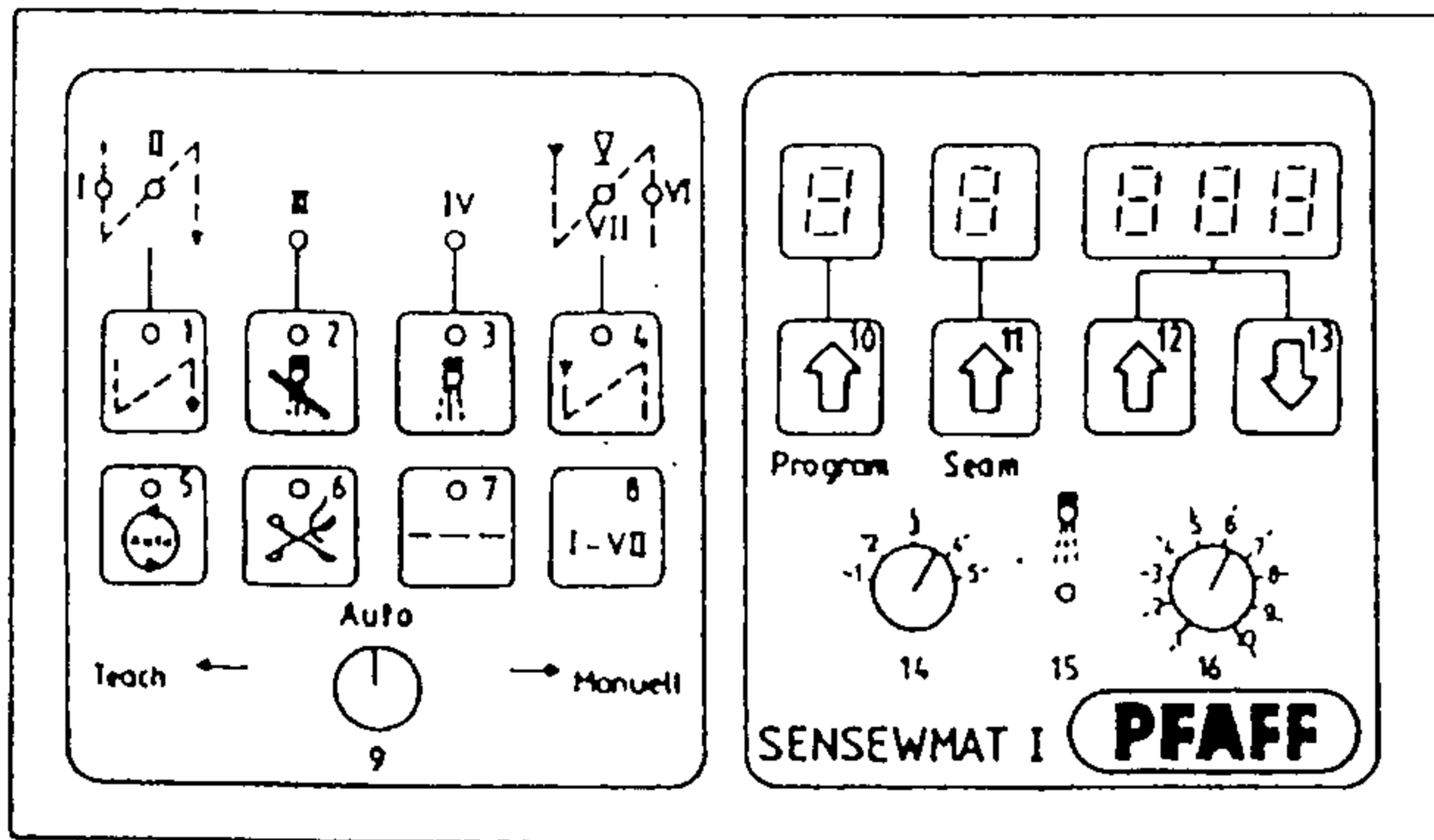

program keys

function keys

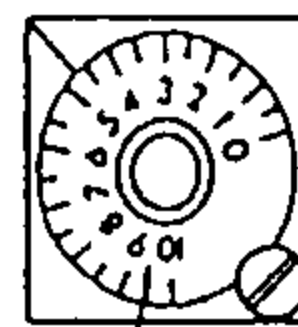
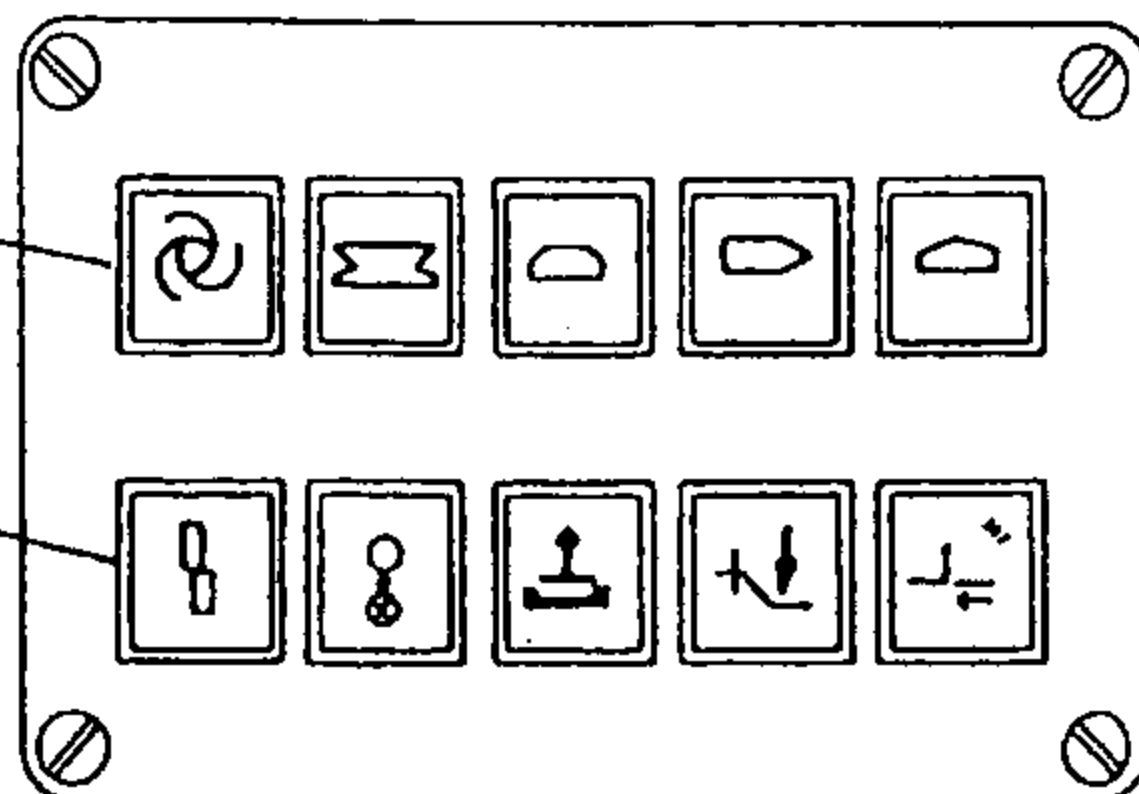

potentiometer for position "turning head center"

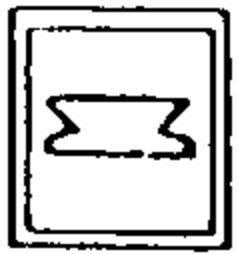

one -piece collar

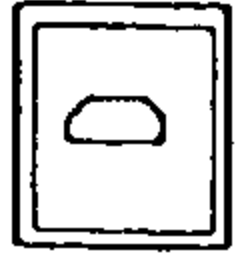

diagonal cuffs

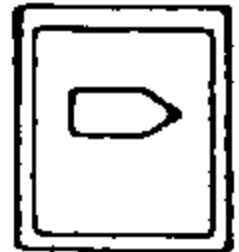

shoulder straps



pocket flaps

no program

key pressed - two piece collar



automatic control on



reset



re-sewing after thread breakage



seam depth 1 or 2 (as required)

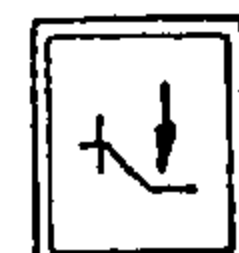

workpiece retainer down,
key depressed - at all seams
key not depressed - only at
long seams

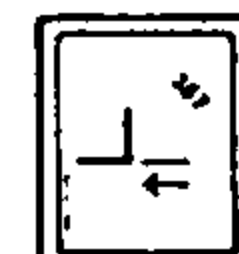

loading guide up
(for working w/o loading guide)

1 Setting the machine up

Set the machine up at its intended place and level it out.*

1.1 Conversion from side operation to front operation

The machine has been assembled at the factory in such a way that it can be operated from position "A" (Fig. 1).

If necessary, the machine can also be operated from position "B".

To this effect, convert the machine as follows:

Unscrew pedal 1 (Fig. 2) at cross member 2 (Fig. 3) of the stand.

Remove cross member 2.

Remove bracket 3 at the pedal (Fig. 2), turn it by 180°, and screw it on again at the left side.

Attach the pedal to the left foot of the stand (Fig. 3), using the two retaining screws.

Turn the master switch under the tabletop by 90° and attach it at the front side.

Fix the operating panel in the two front holes on the tabletop.

* In case of transportation damage, notify the forwarding agent and the Pfaff agency responsible.

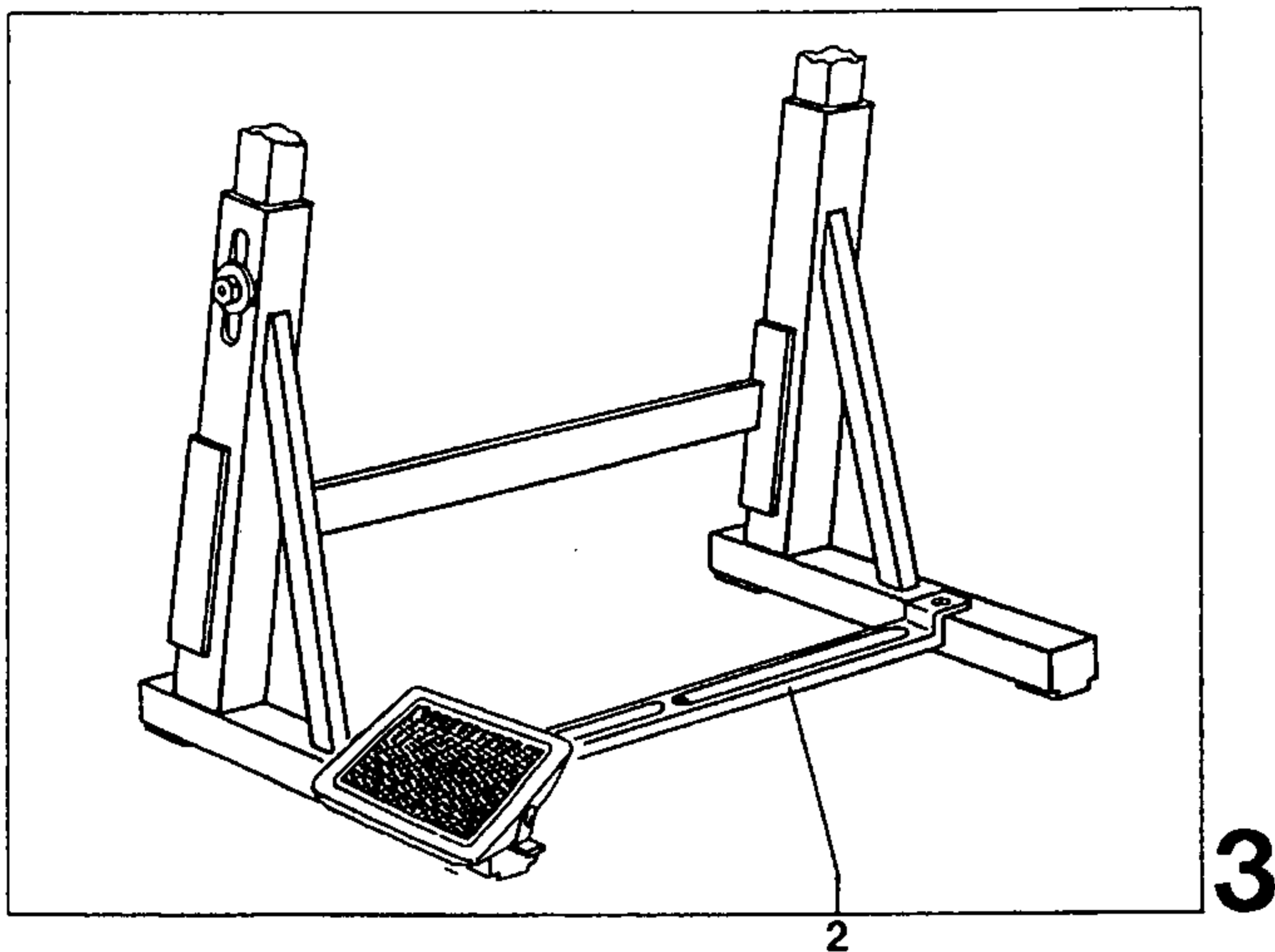
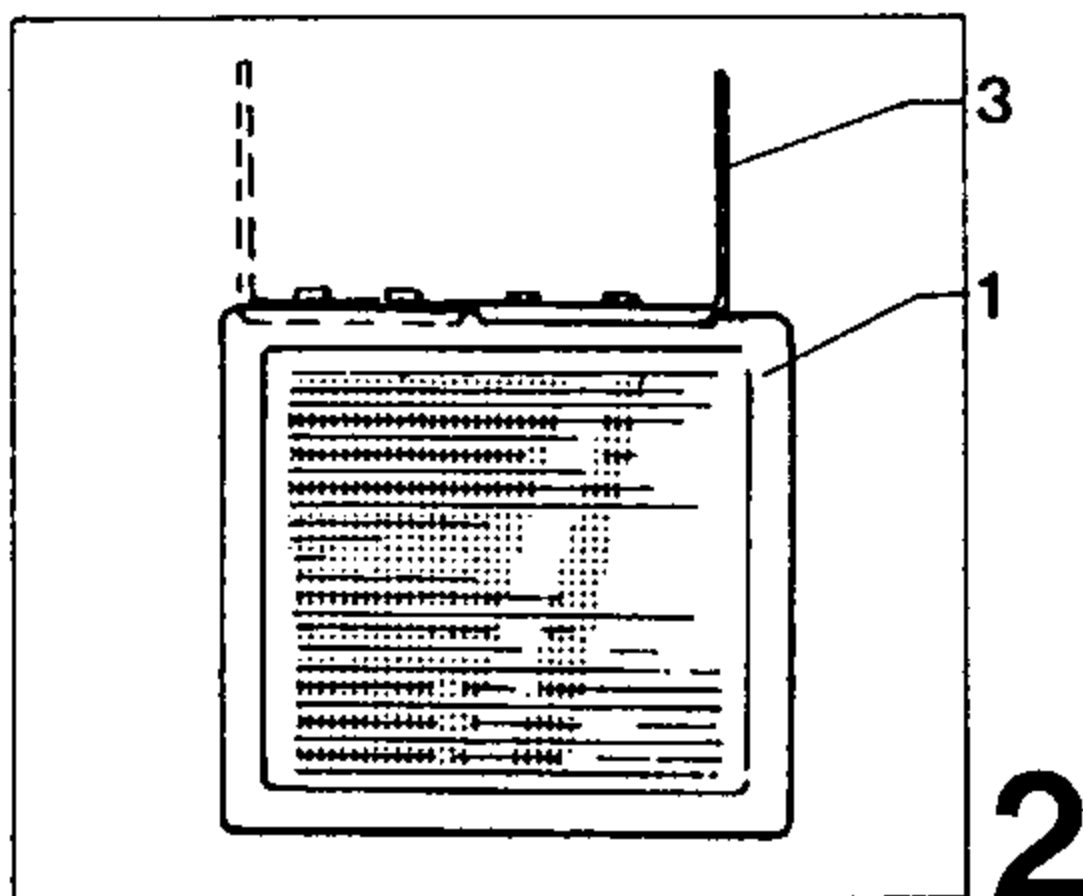
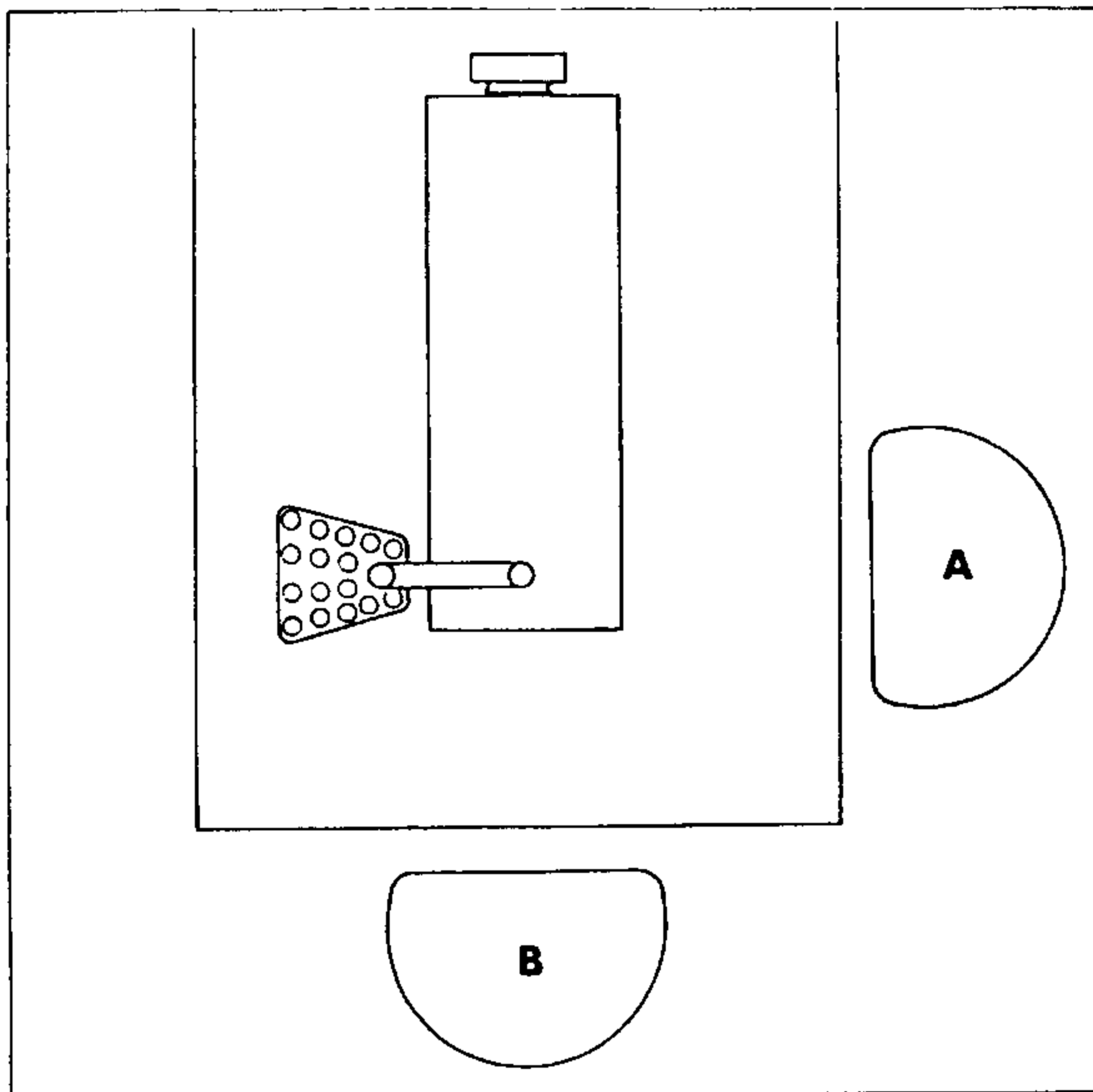

2 Connection of power and compressed air

2.1 Compressed air

Connect compressed-air hose (6 mm inside diameter) to coupling 1 (Fig. 1).

Minimum pressure in feed system: 7 bar

Working pressure: 6 bar

Pressure regulation: valve 2

2.2 Electrical power

2.2.1 Machines with specification plate

Safe operating voltage: see line 3 (Fig. 2)

Operating- and mains voltage the same: connect machine to an earthed socket.

2.2.2 Machines without specification plate

Safe operating voltages: see motor rating plate

Check:

Open motor connection box.

Delta connection = lower voltage

Star connection = higher voltage

Note circuit diagram!

Operating- and mains voltage the same: connect machine to an earthed socket.

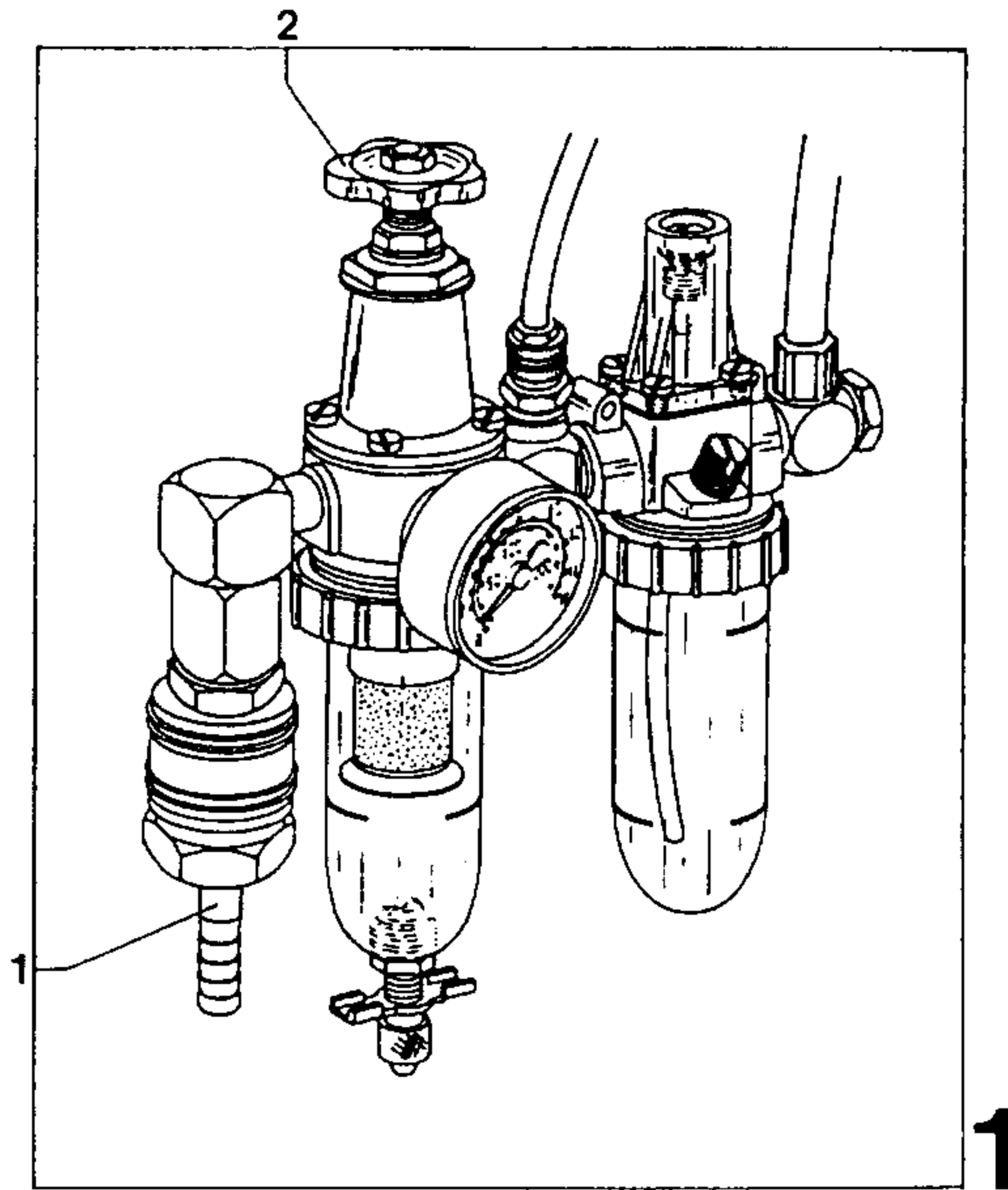

PFAFF			
<input type="text"/>	T.-Nr.	<input type="text"/>	3
Stromart	<input type="text"/>	Frequenz	<input type="text"/> Hz
Betriebsspg.	<input type="text"/>		V
Steuerspg.	<input type="text"/>	Trafo	<input type="text"/> V
Nennstrom	<input type="text"/>		A
Hauptsicherung	<input type="text"/>		A
Schaltplan	<input type="text"/>		2

3 Checks

3.1 Air filter/lubricator

For correct oil level, see markings on container 1 (Fig. 1).

If necessary, top up oil according to section 41.3.

3.2 Sewing machine

For correct oil level, see markings on oil sight glass 2 (Fig. 2).

If necessary, top up oil through the hole (see arrow in Fig. 2).

We recommend Pfaff sewing machine oil, part No. 280-1-120 144, or oil with a mean viscosity of 22 mm²/s at 40° C and a density of 0.865 g/cm³ at 15°.

3.3 Direction of rotation

The balance wheel must turn in the direction of the arrow (Fig.3).

Check:

- switch on machine
- set rotary switch 3 (Fig. 4) at MANUAL
- raise presser foot by means of lifting lever
- press pedal slightly forwards and watch balance wheel

If the direction of rotation is wrong, exchange the poles in the mains plug.

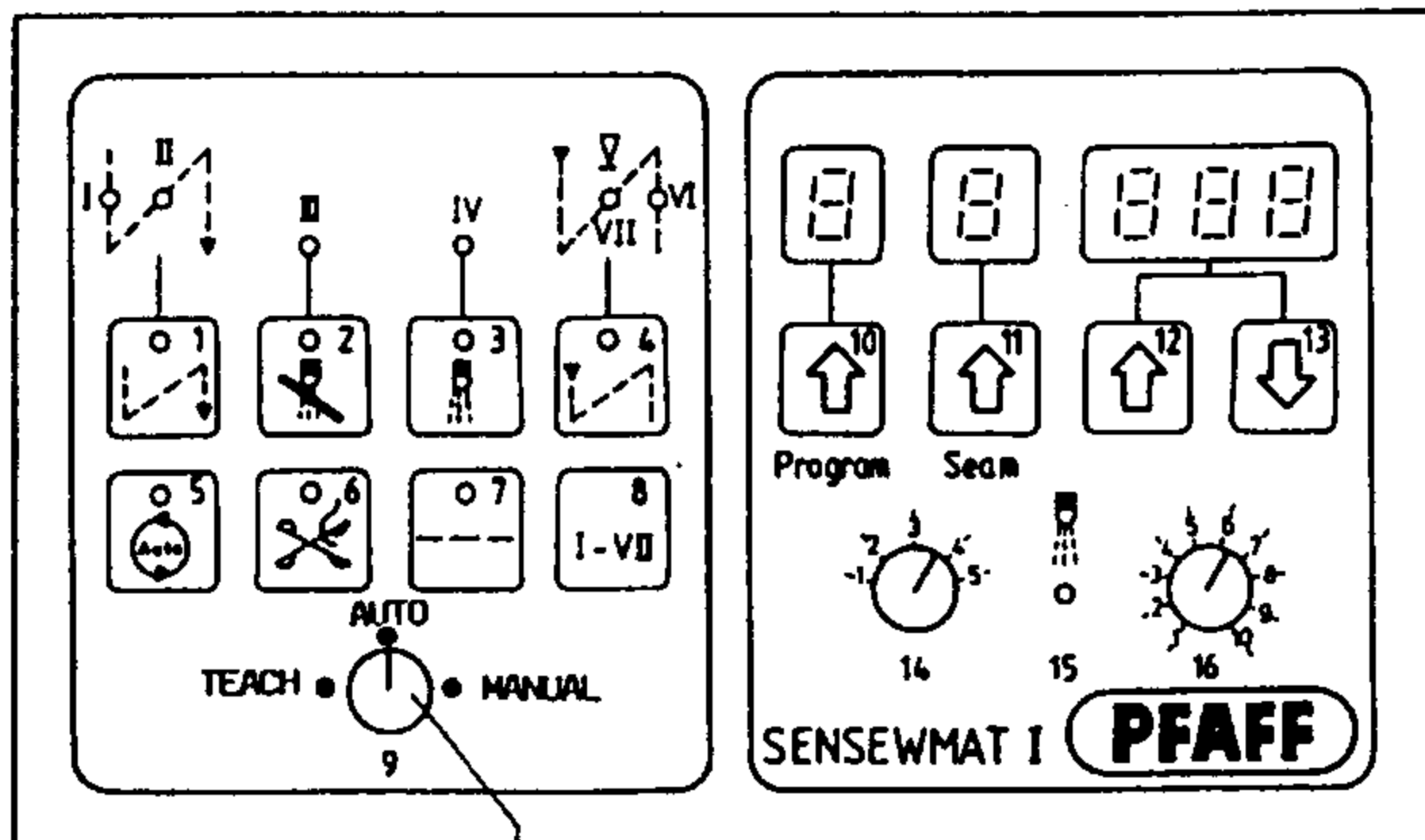
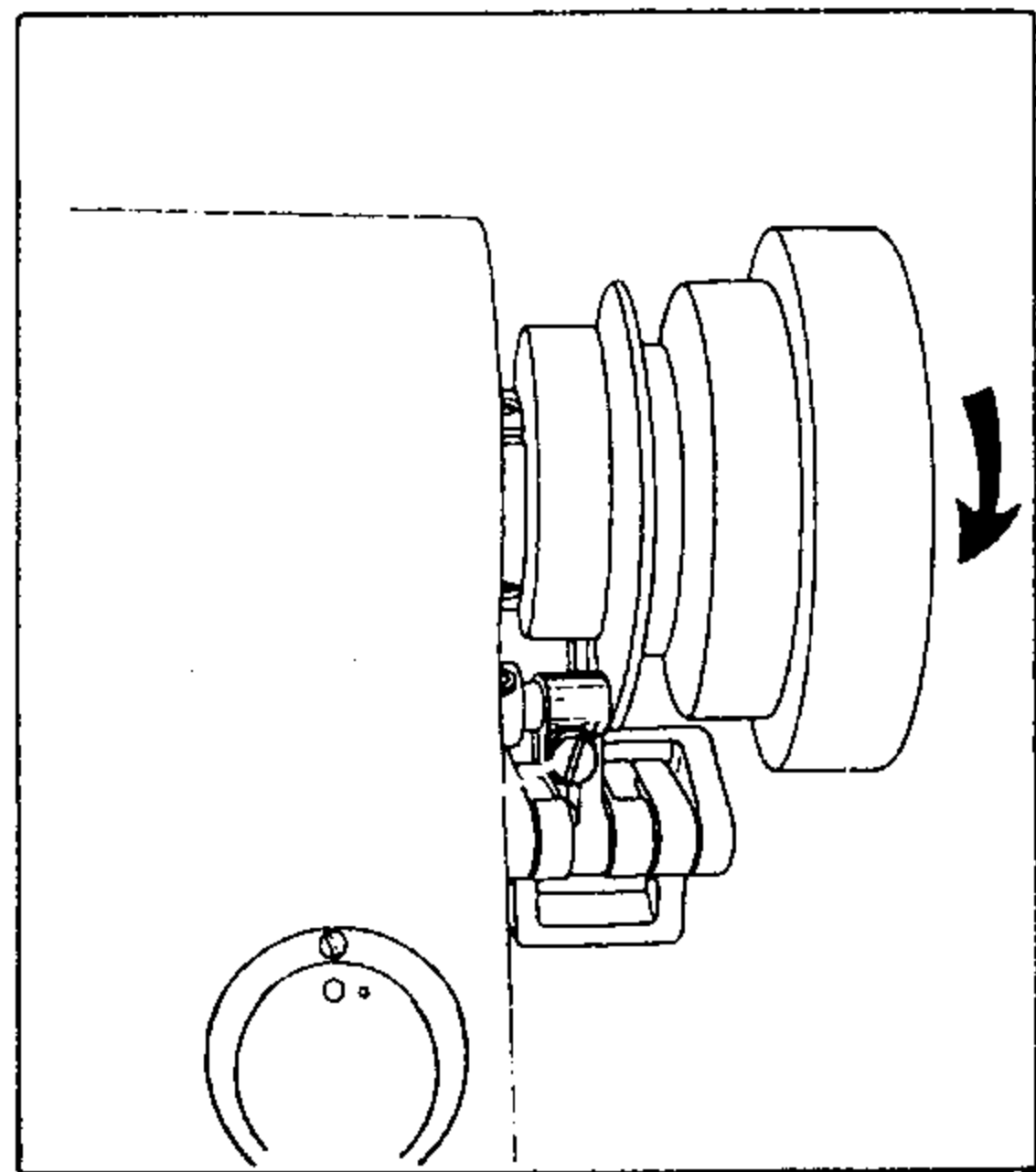
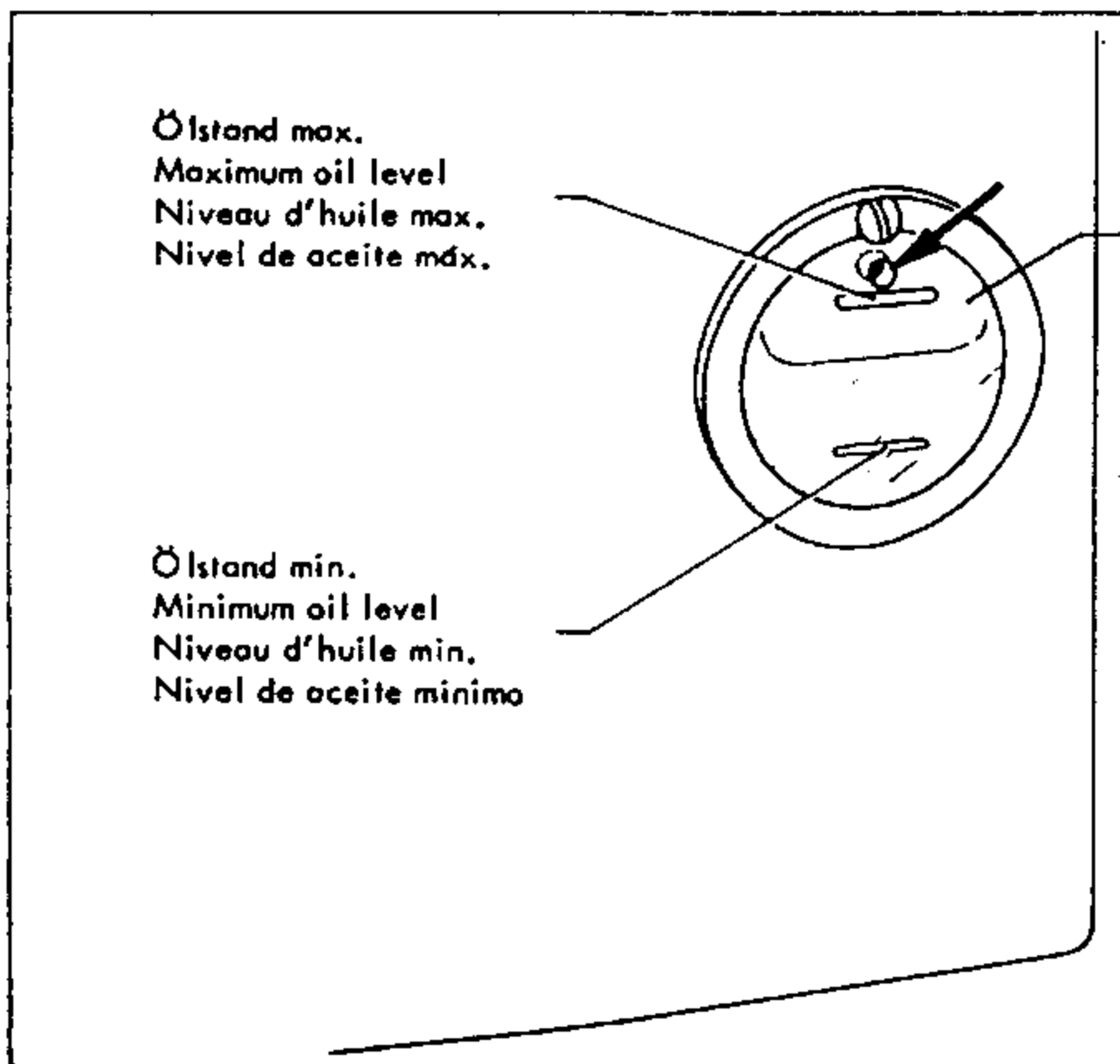
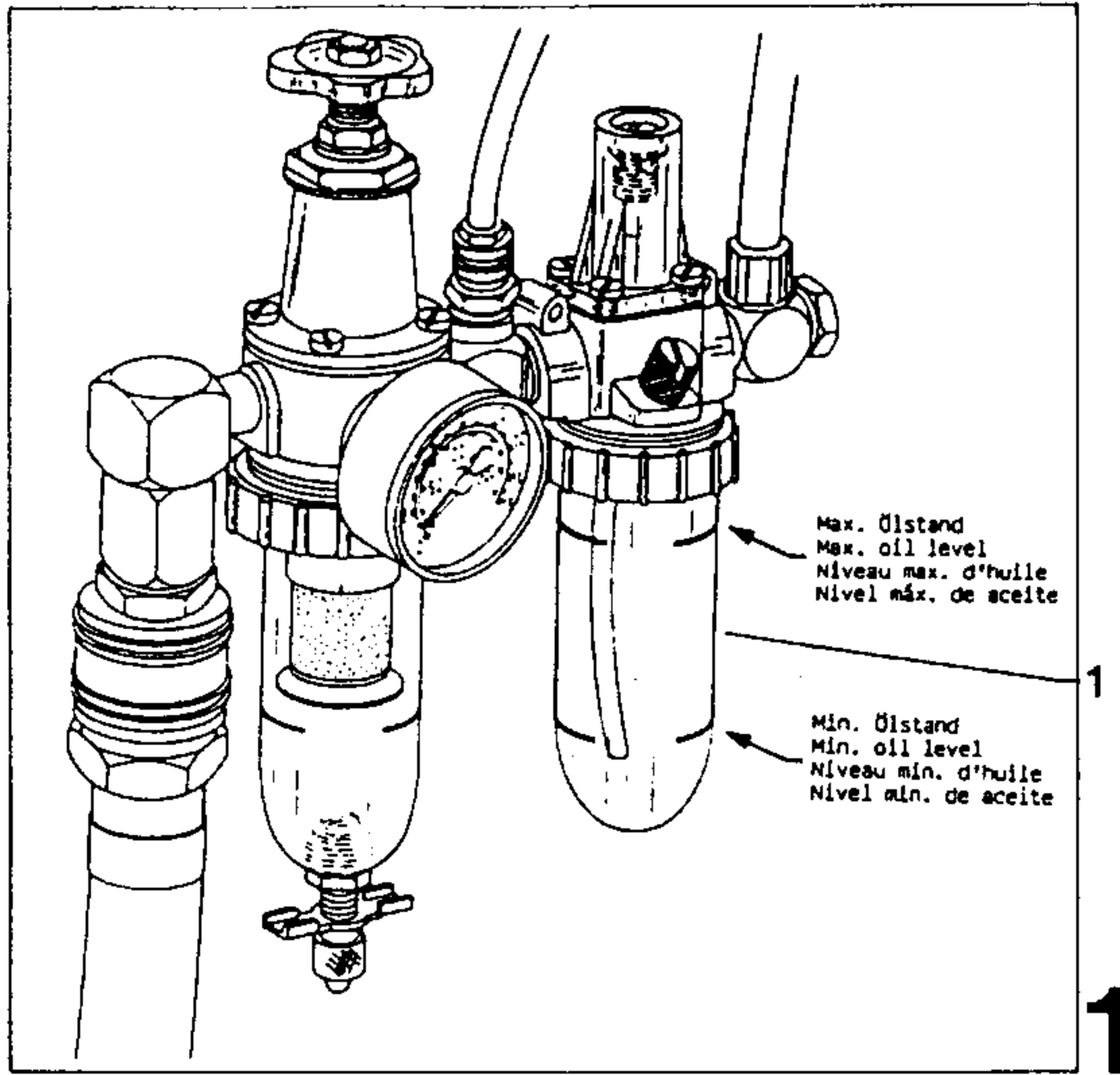

4

3.4 Hook lubrication

On machines that are operated for the first time or that have not been in use for a longer period of time (1 to 2 months), check the oil feed by all means.

Check oil level according to section 3.2.

Switch off machine.

Raise presser foot by means of lifting lever.

Unscrew needle plate.

Fully close oil regulating screw 4 (Fig. 5), then open it again by 2 to 3 turns.

Switch on machine.

Press pedal forwards
- machine runs.

Run the machine until the sewing hook starts to emit oil.

Fully close oil regulating screw 4 again, then open it by half a turn.

Run the machine for about a minute.

Place a piece of paper on the needle plate cutout.

Run the machine for 10 seconds; a fine trace of oil must appear on the piece of paper opposite the hook raceway.

If necessary, re-adjust oil feed accordingly at oil regulating screw 4.

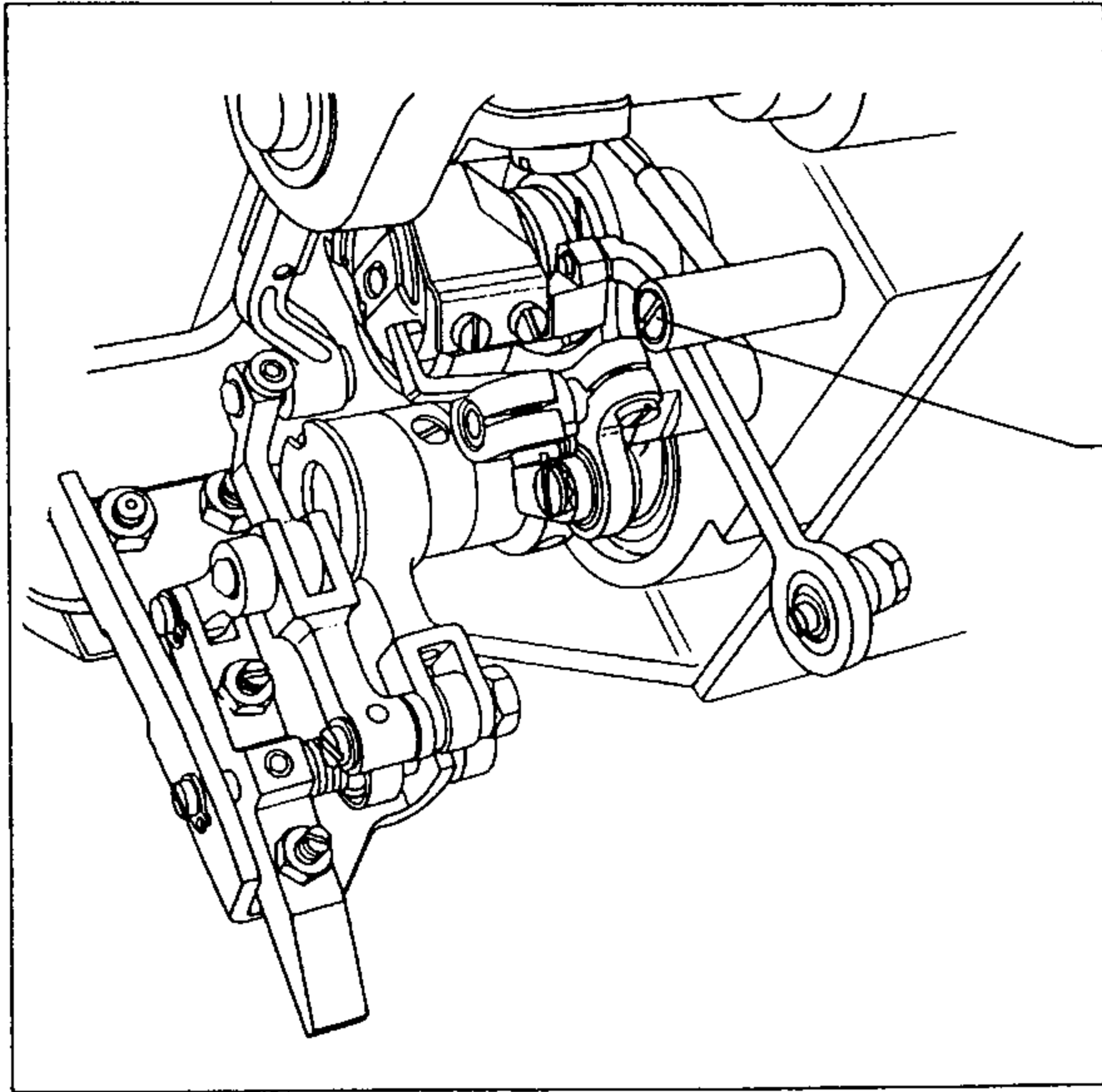

5

4 Preparatory work for adjusting the sewing machine

For most of the adjustments, the sewing machine can remain installed in the machine stand. To carry out work below the baseplate, tilt the machine back.

For a number of adjustments, however, it is recommendable to take the sewing machine out of the machine stand.

4.1 Tilting the sewing machine over

Switch off machine.

Move turning head 1 (Fig. 1) in the position shown in Fig. 1 by turning adjusting wheel 2.

Tilt sewing machine back and place it on sewing head rest 3 (Fig. 2).

4.2 Removal of the sewing machine

Switch machine off and remove compressed air hose at the air filter/lubricator.

Unscrew belt guard above the table top and remove the V-belt.

Pull out the following plugs:

- synchronizer plug **b1** (Fig. 3) at motor control board
- plug **b13** for thread trimmer at motor control board
- sensor plug **j103** at power unit below table top
- light emitter plug **j104** at power unit below table top
- thread monitor plug (**0**)
- plug for bobbin-thread-end sensor (**U**)
- plug **y13** from distributor to **b15** at motor control board
- plug **b6** for proximity switch of -900 at front side of control box
- plug **b7** for proximity switch of automatic presser foot lift at front side of control box
- photocell plug at amplifier 4 (Fig. 2)
- multi-contact plug 5 (Fig. 2)

Remove pneumatic feed lines from cylinders for automatic presser foot lift and for forward/reverse feed.

Loosen knurled ring 6 (Fig. 2) and remove coupling 7.

Lift machine out of its bearing.

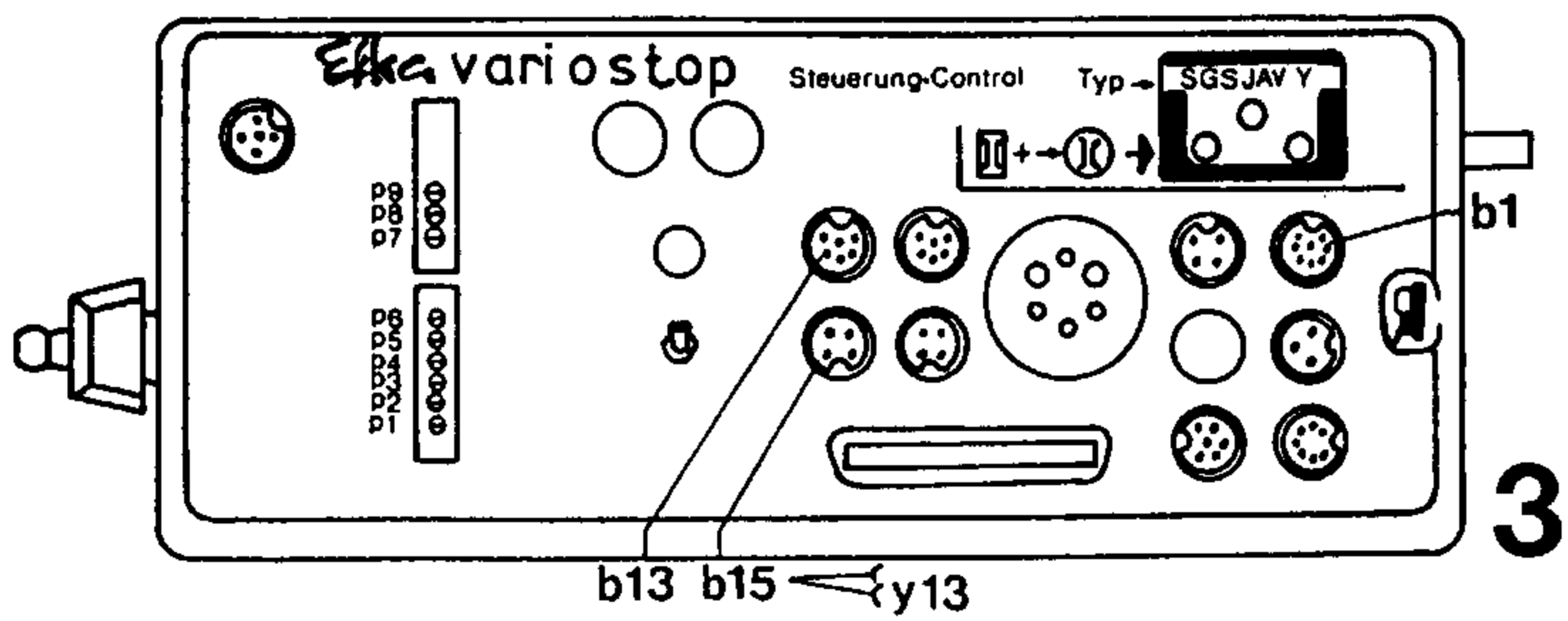
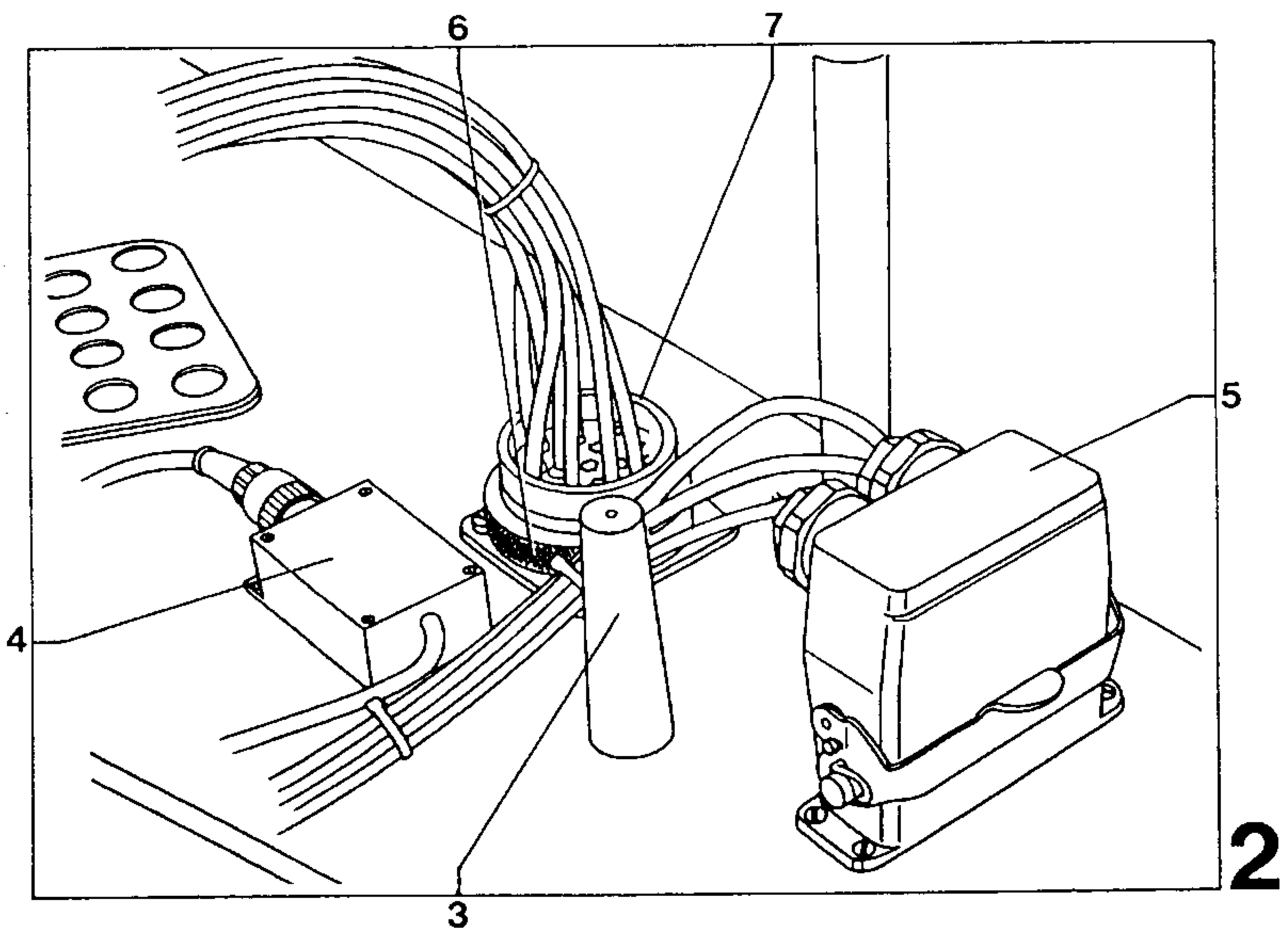
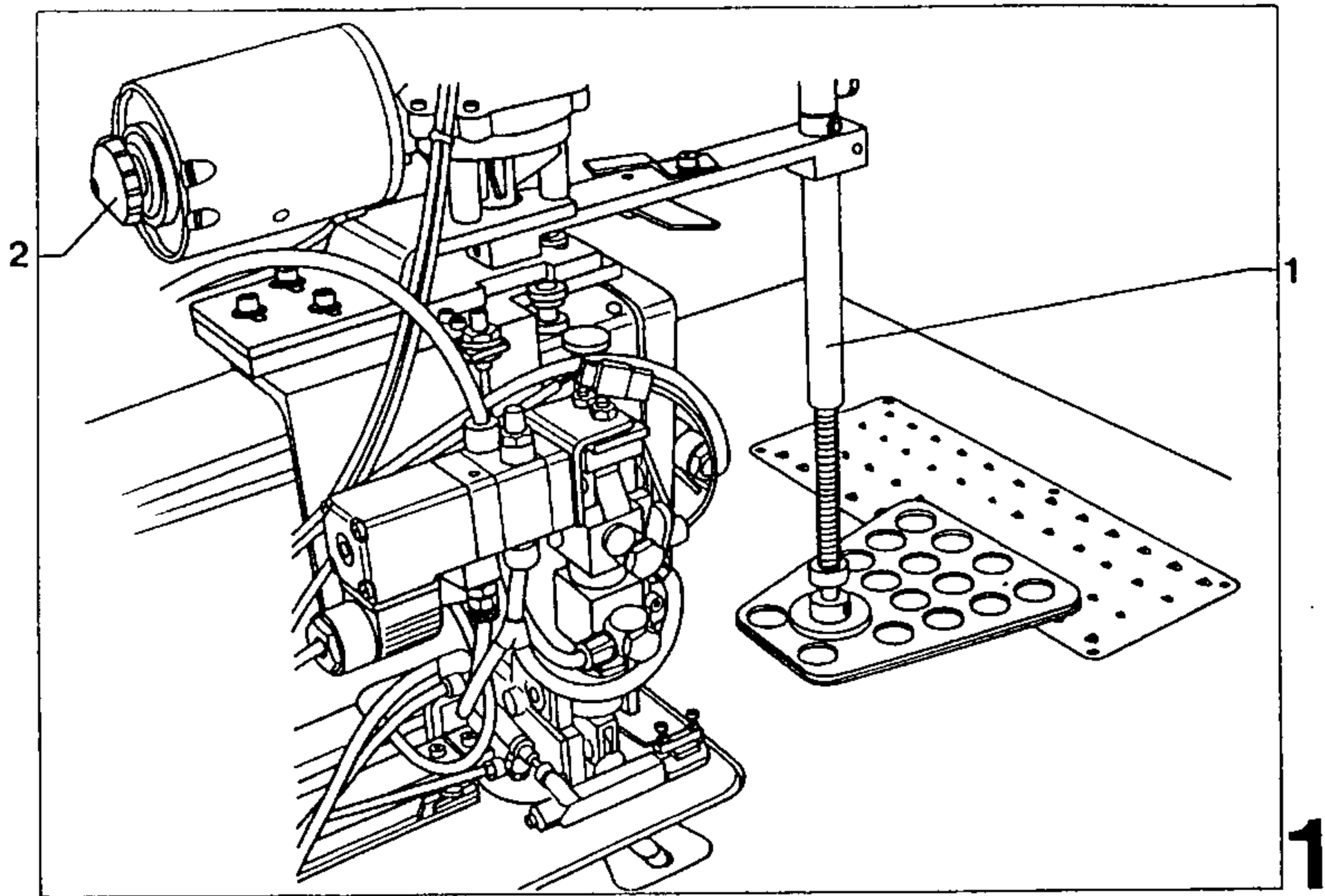

4.3 Blocking the sewing machine at different positions for adjustment

No C-clamp must be used on the needle bar of a Pfaff series 480 machine as this would damage the special coating.

For blocking the machine at the required needle bar position, the adjustment pin must be inserted in the respective hole so that it reliably enters the recess behind the bearing plate, thus blocking the machine.

4.4 Functions of the adjustment holes

Adjustment hole 1

= 0.6 mm past top dead center of needle bar.

Adjustment hole 3

= 0.6 mm past bottom dead center of needle bar.

Adjustment hole 4

= 1.8 mm past bottom dead center of needle bar (needle rise position).

Adjustment hole 5

= top dead center of needle bar.

Adjustment hole 6

= 4 mm past bottom dead center of needle bar.

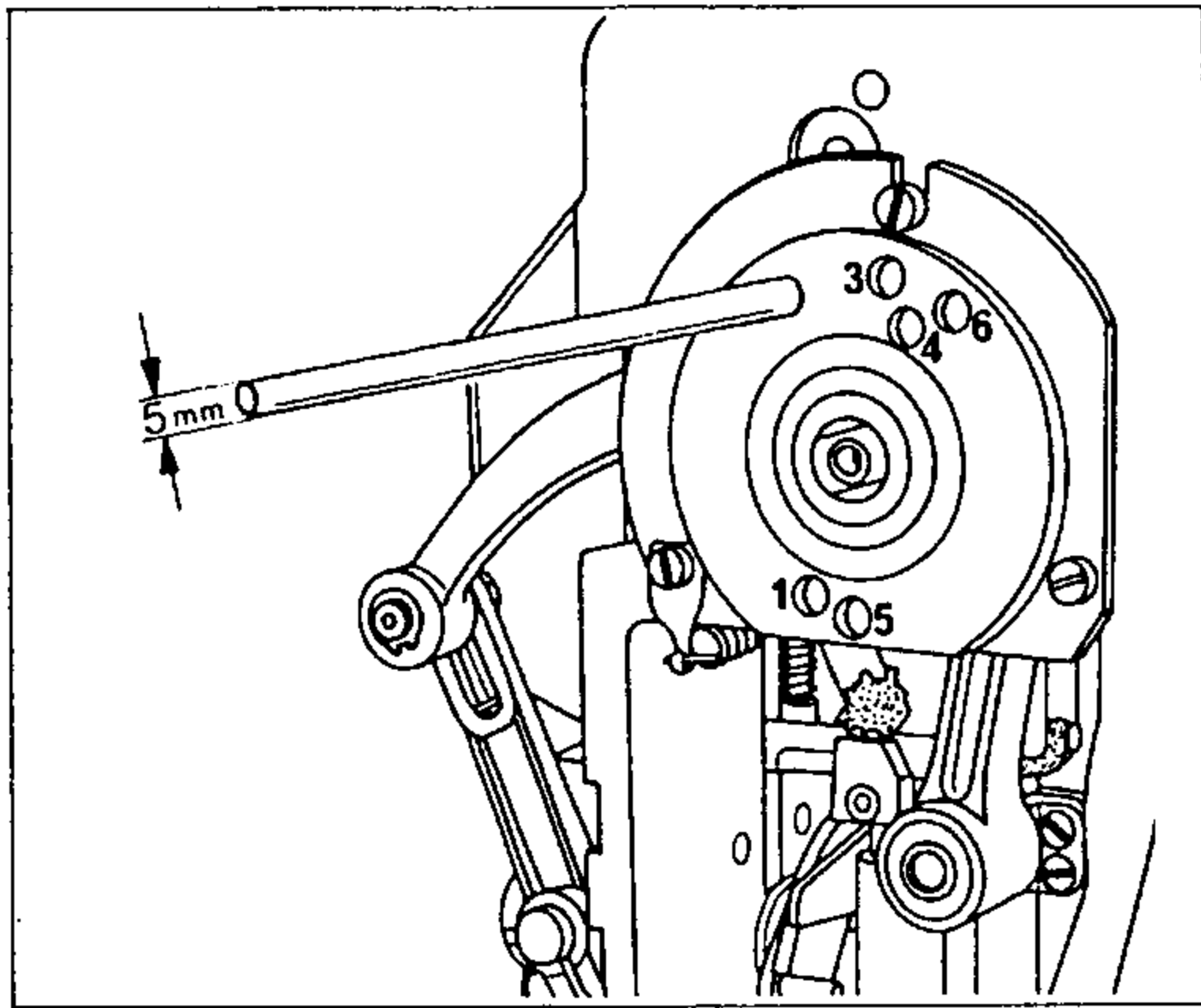

4

5 Position of needle in needle hole

A straight needle must enter the needle hole exactly in the center.

Loosen screws 1, 2, and 3.

Position the needle bar frame so that the needle stitches exactly in the center of the needle hole.

Tighten screw 3 firmly and screw 2 just lightly.

Use screw 1 to pull the guide pin behind it towards the eye of the needle bar frame, then tighten screw 1.

Remove the needle.

Loosen screw 2, turn the balance wheel a few times (to eliminate any distortion) and tighten screw 2 again.

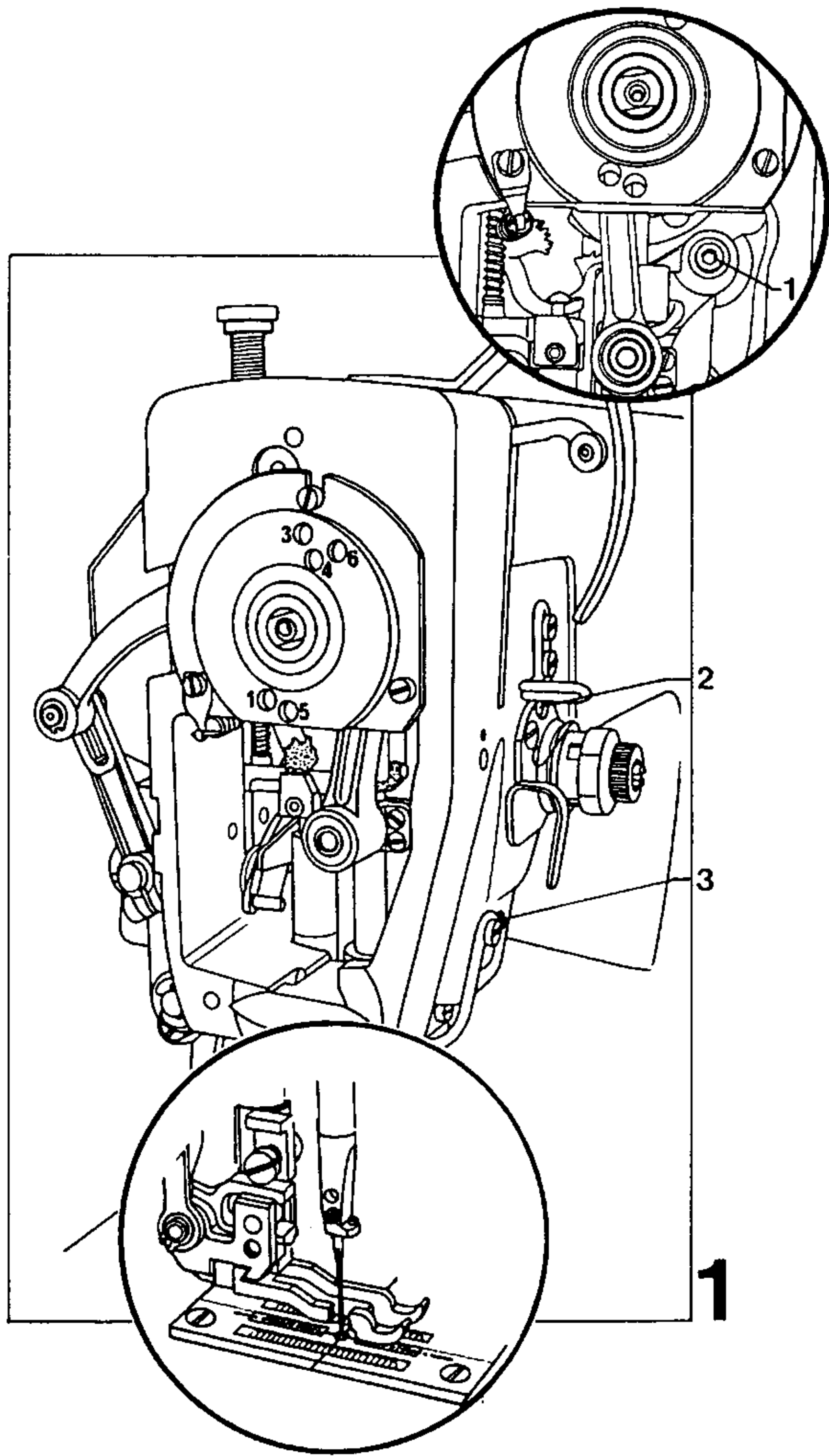

6 Neutralizing the bottom feed

When the stitch length is "0" and the balance wheel is turned, the bottom feed dog must make no feeding movement.

6.1 Adjustment with the gearcase closed

Position feed regulating lever 1 fully down (Fig. 1).

Loosen screw 2.

Turn eccentric bushing 3 so that marking 4 faces down and the edge of the flat is at an angle of about 45° to the front of the machine (= preliminary adjustment, for final adjustment see section 19).

Tighten screw 2.

Insert a big screwdriver in the slot of circlip 5 (Fig. 2) and hold feed rock shaft 6 fast with it.

Loosen screw 7.

While turning the balance wheel, turn circlip 5 with the big screwdriver so that the feed dog makes no feeding movement.

In this position, tighten screw 7.

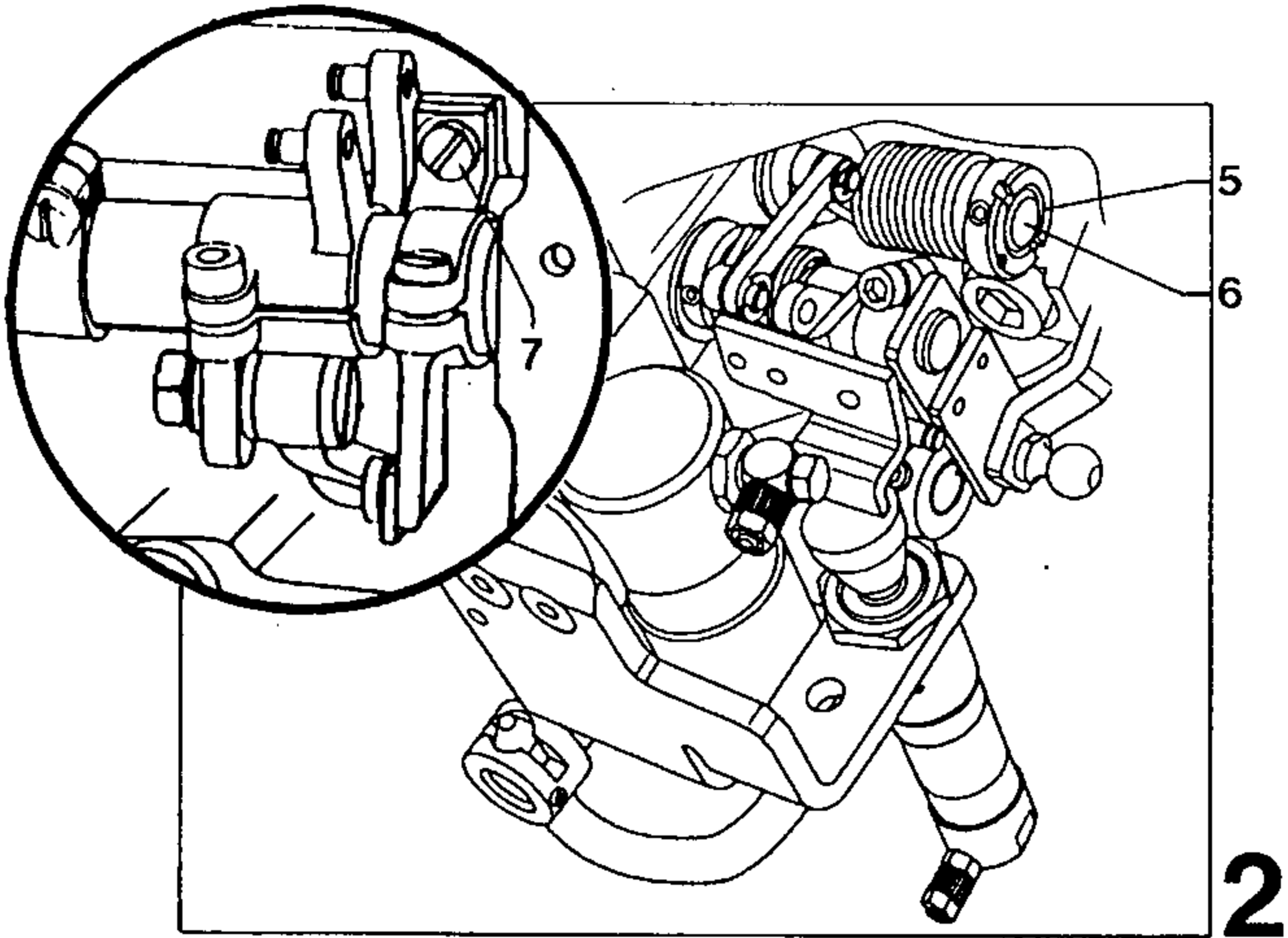
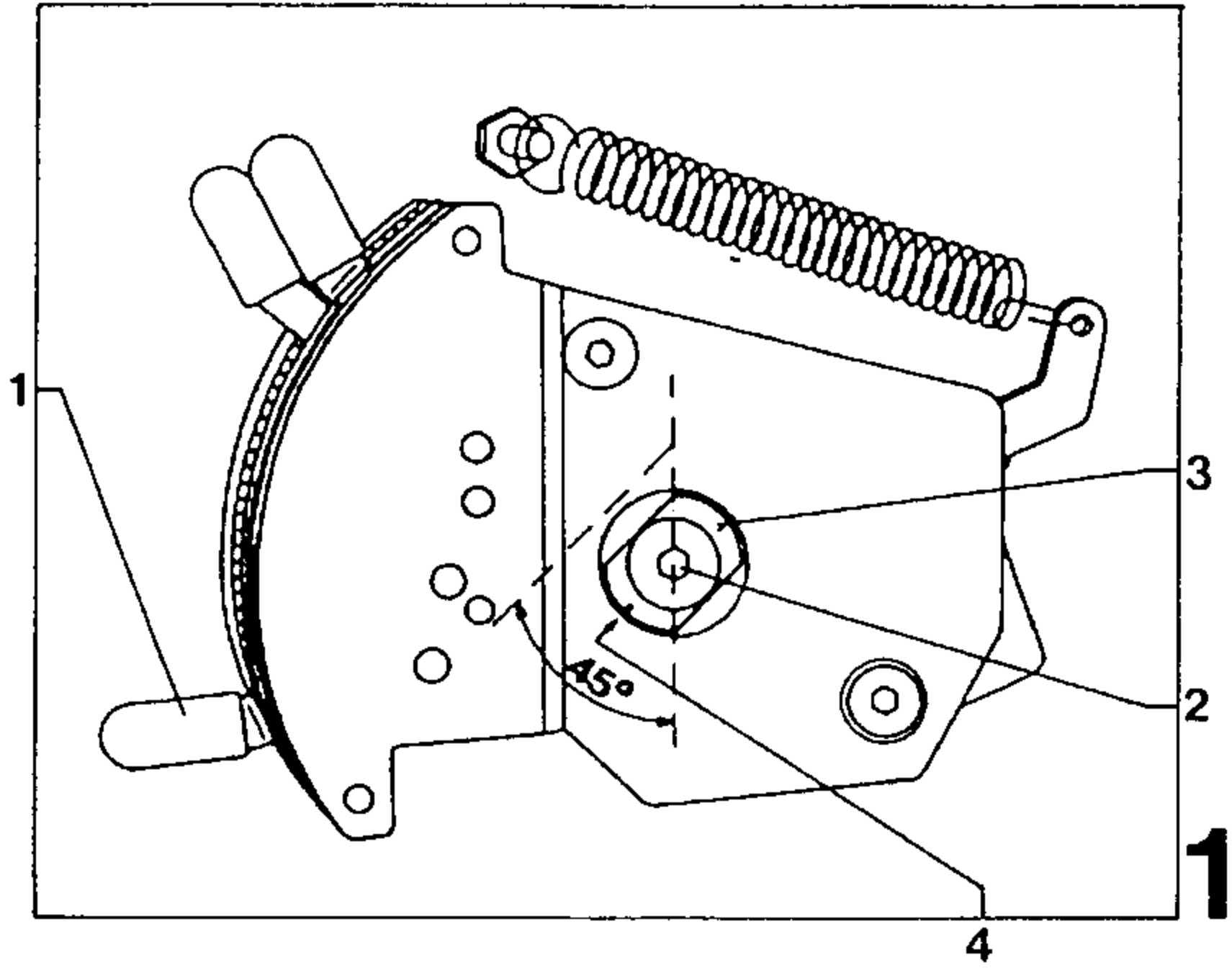

6.2 Adjustment with the gearcase open

Position feed regulating lever 1 fully down (Fig. 3).

Loosen screw 2.

Turn eccentric bushing 3 so that marking 4 faces down and the edge of the flat is at an angle of about 45° to the front of the machine (= preliminary adjustment, for final adjustment see section 19).

Tighten screw 2.

Unscrew the gearcase cover; watch for leaking oil.

Take out the oil pad.

Loosen screw 8 (Fig. 4) so that crank 9 can just be turned on the shaft.

Turn the crank so that at stitch length "0" the bottom feed dog makes no feeding movement when the balance wheel is turned.

Tighten screw 8.

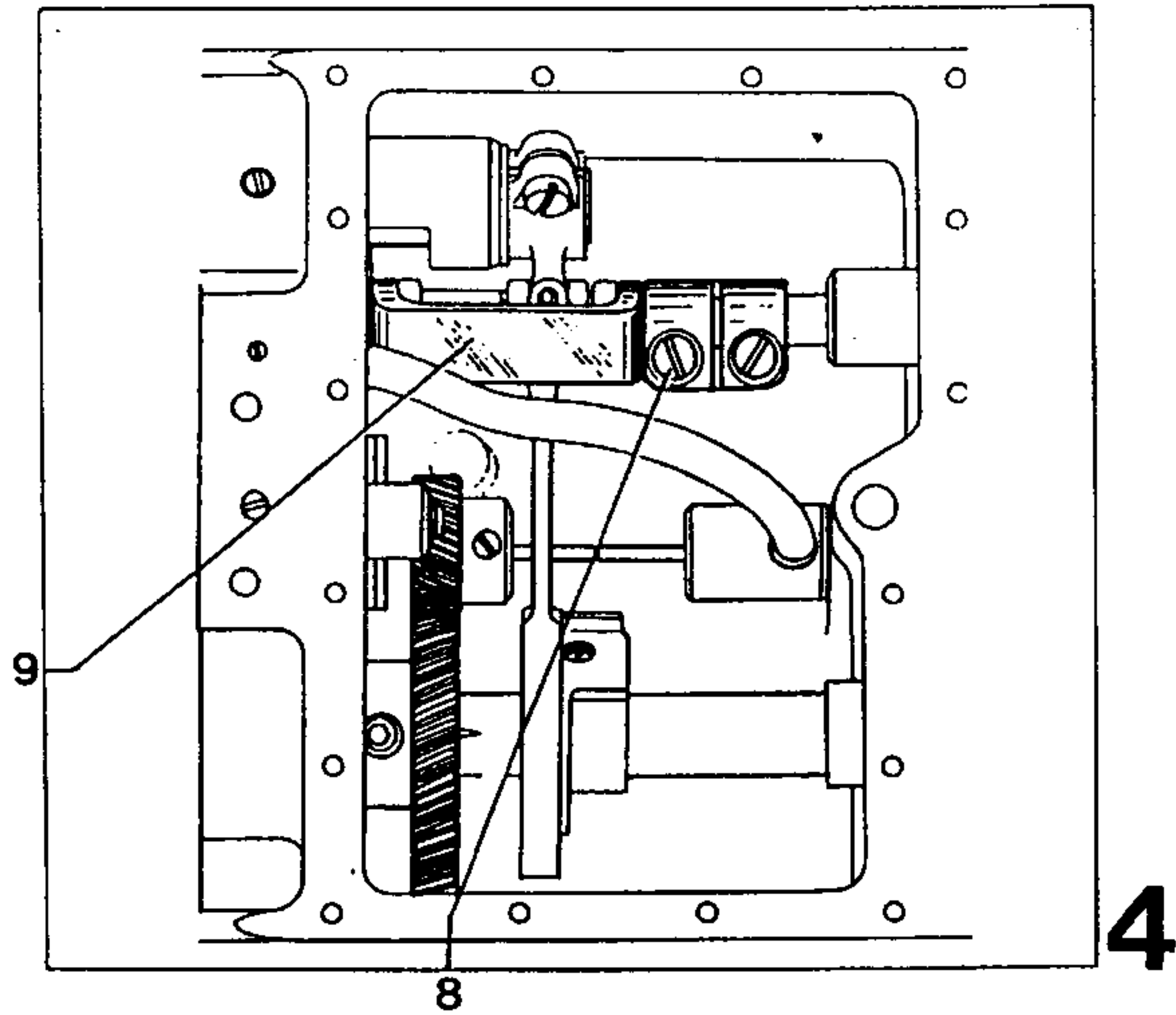
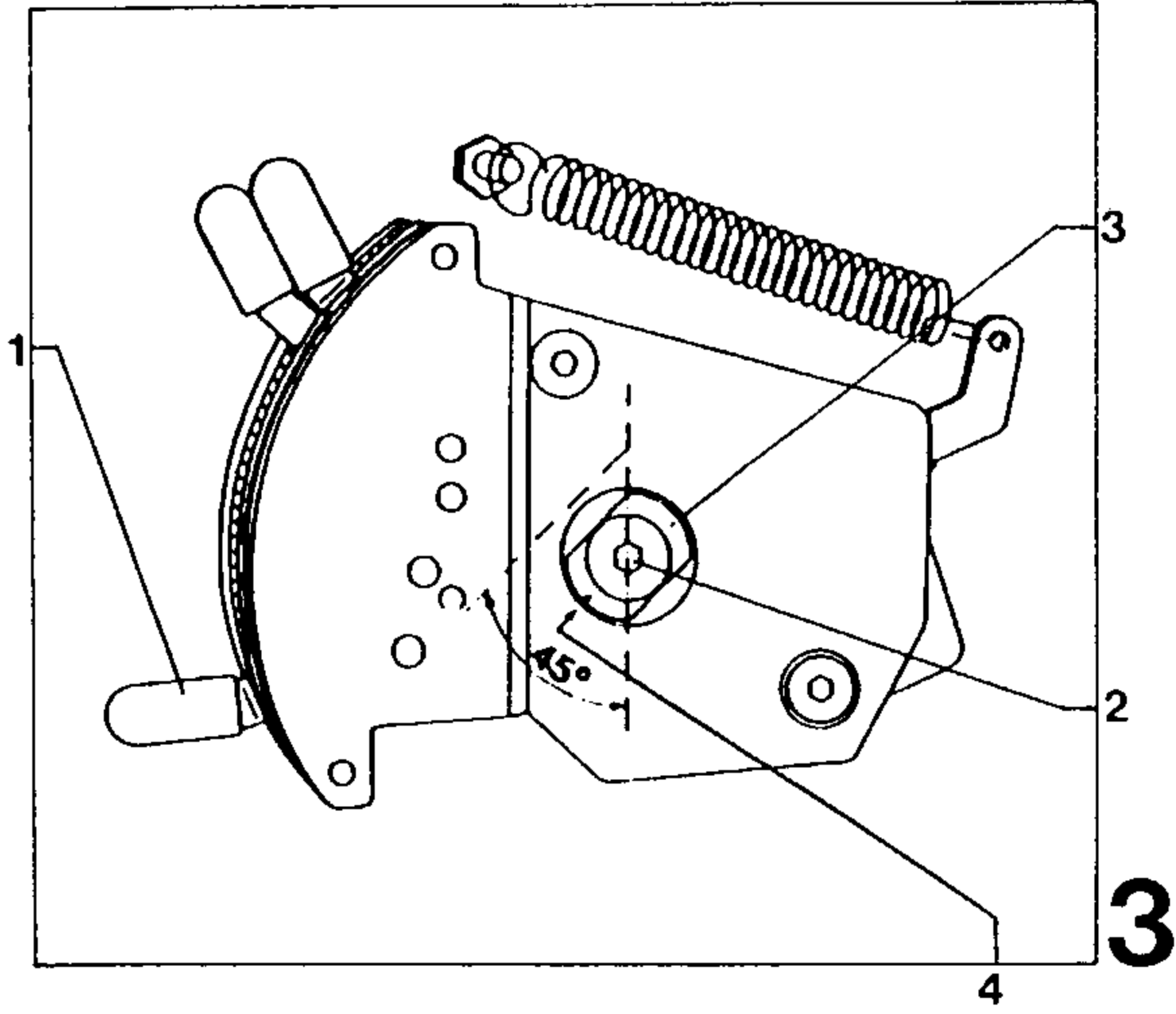

7 Bottom feed advancing motion

With the longest stitch length set and the needle bar 0.6 mm past t.d.c. (= adjustment hole 1), the bottom feed dog must not move when the reverse feed lever is actuated.

Set the max. stitch length of 4.5 mm at lever 1 (Fig. 1).

Loosen screws 2 (Fig. 2).

Set the needle bar 0.6 mm past t.d.c. and insert the adjustment pin in hole "1".

To facilitate adjustment, insert a screwdriver in the slot of feed driving crank 3 (Fig. 3).

Insert an allen key in the clamp screw of fixing collar 4 (Fig. 1).

Move the shaft forwards and backwards by means of the allen key and turn feed driving eccentric 5 (Fig. 2) so that

- cutout 6 in feed driving eccentric 5 is visible
- the bottom feed dog, i.e. the screwdriver is completely motionless.

In this position, tighten the accessible screw 2.

Take out the adjustment pin.

Tighten the second screw 2.

Check this adjustment.

Remove screwdriver and allen key.

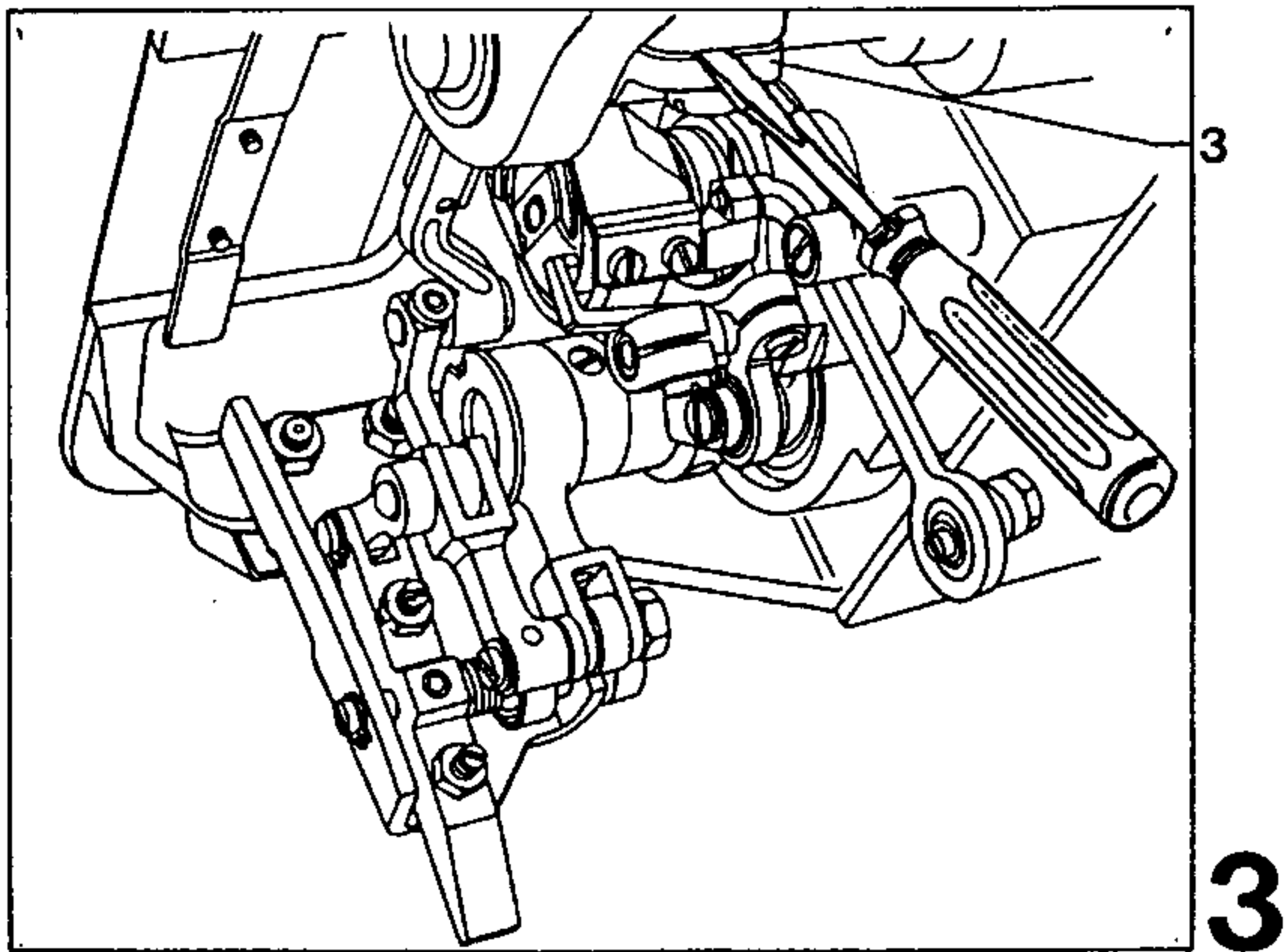
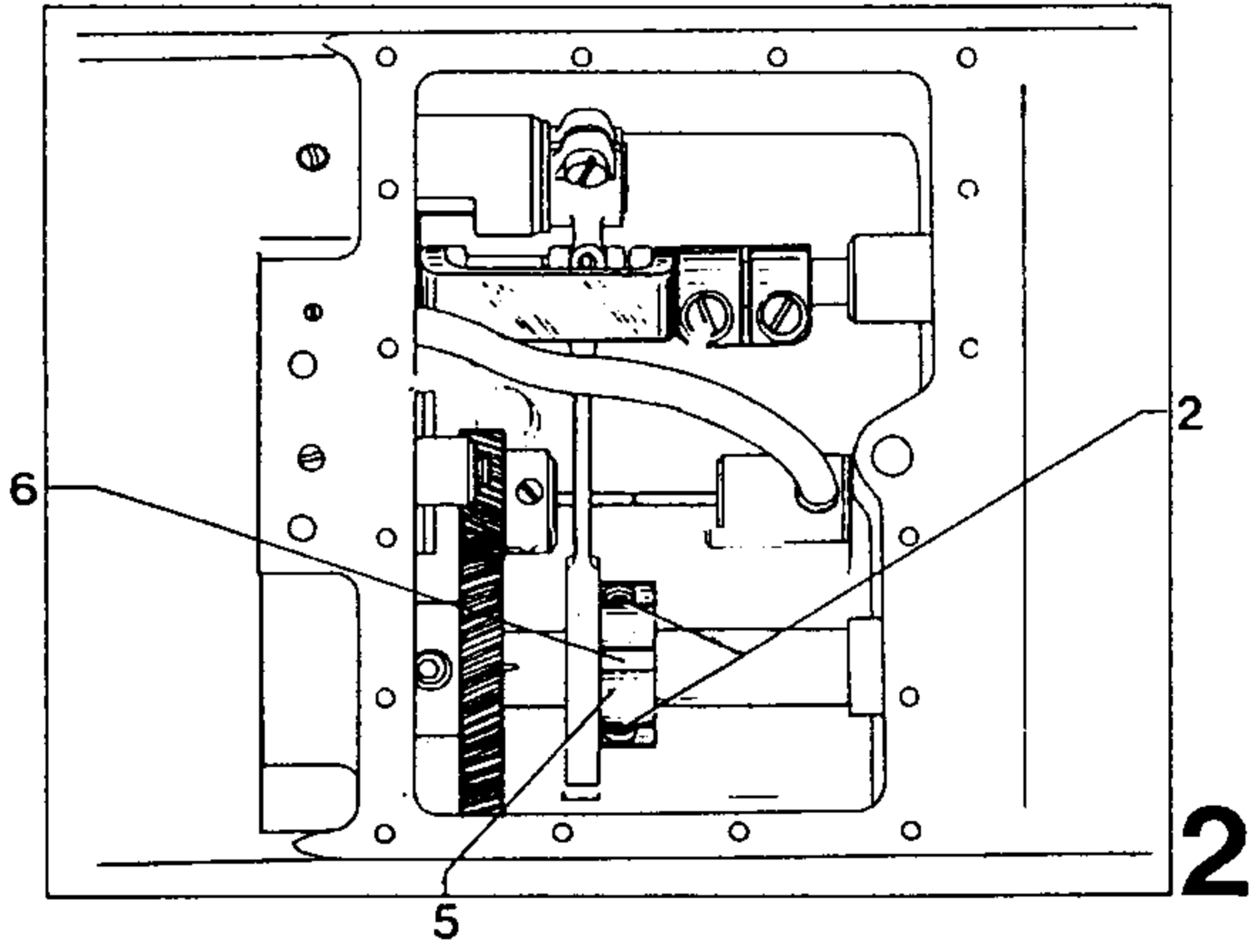
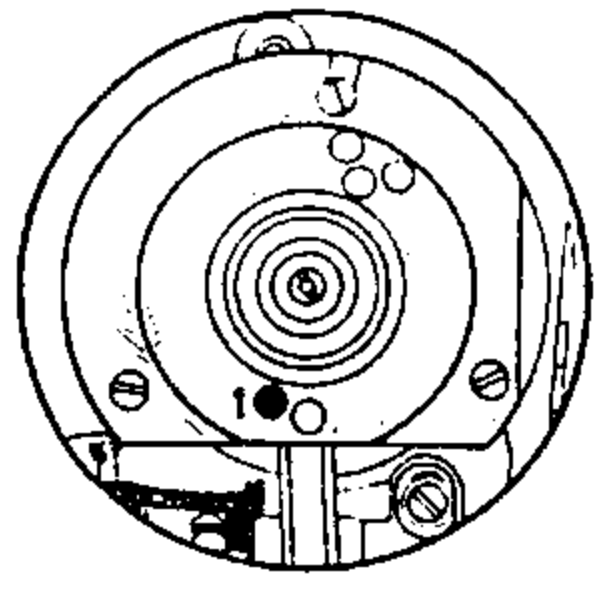
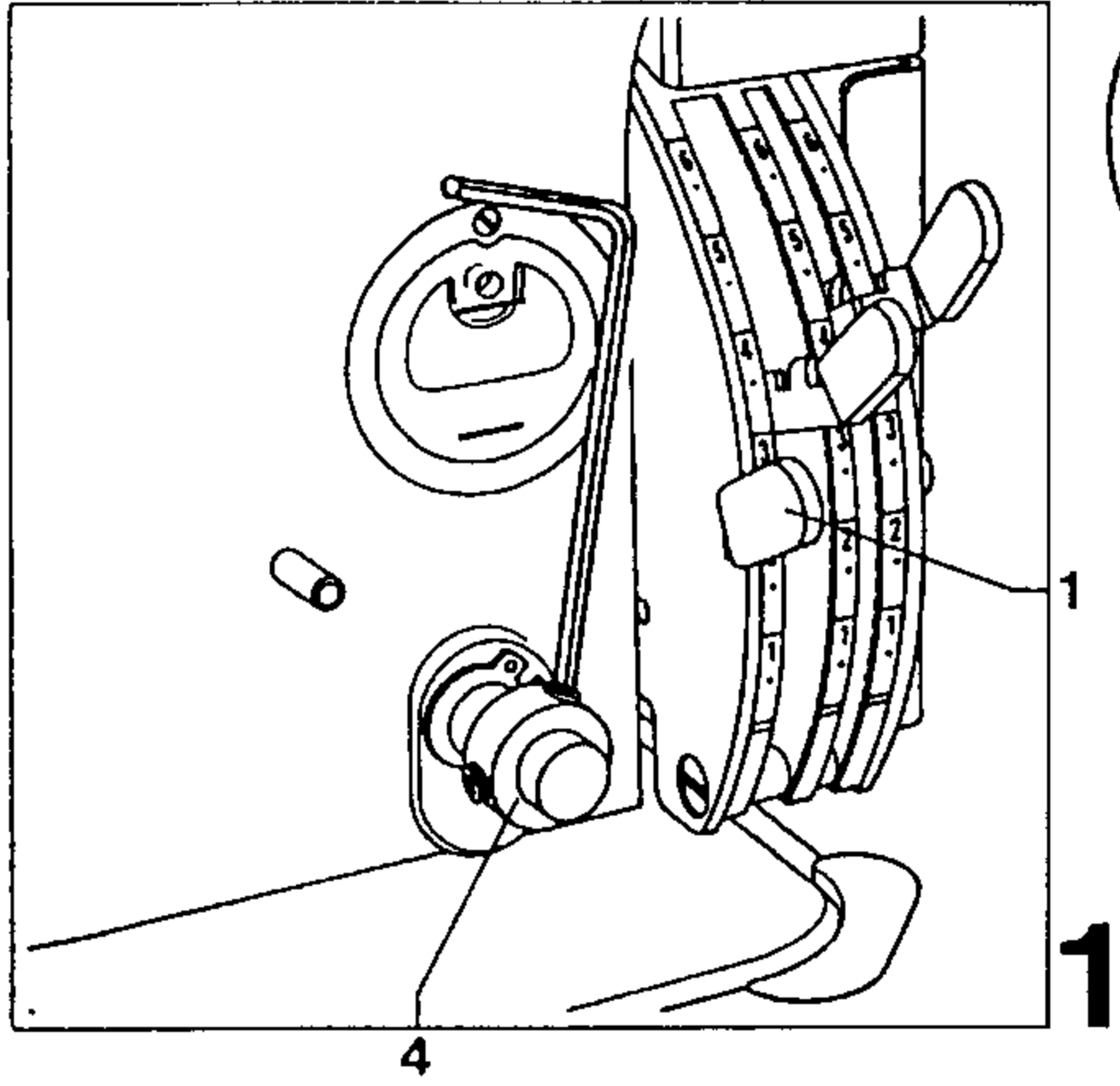

8 Bottom feed lifting motion

When the stitch length is set at "0" and the needle bar 0.6 mm past top dead center (= adjustment hole "1"), the bottom feed dog must be at its t.d.c. The groove in lifting eccentric 1 must face down (Fig. 1.1).

Set stitch length "0".

Loosen screws 2 (Fig. 1).

Set the needle bar 0.6 mm past t.d.c. and insert the adjustment pin in hole "1".

Turn lifting eccentric 1 so that the feed dog is at its highest position; the groove of the eccentric must face down.

Tighten the accessible screw 2. Make sure there is a small amount of play between lifting eccentric 1 and the connecting rod behind it.

Take out the adjustment pin and tighten the second screw 2.

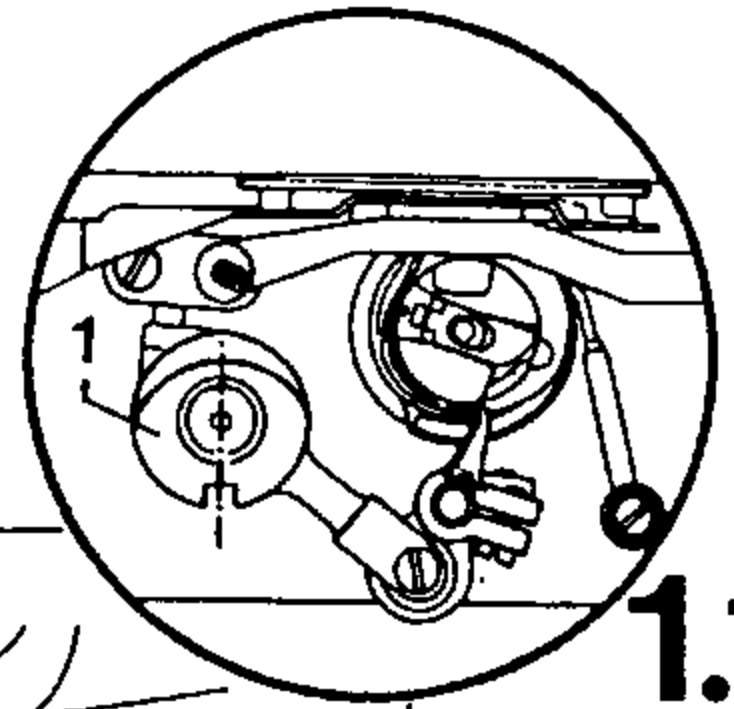
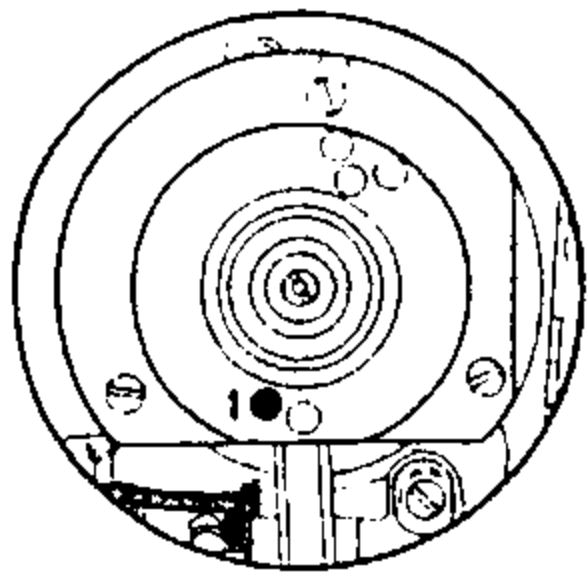

1.1

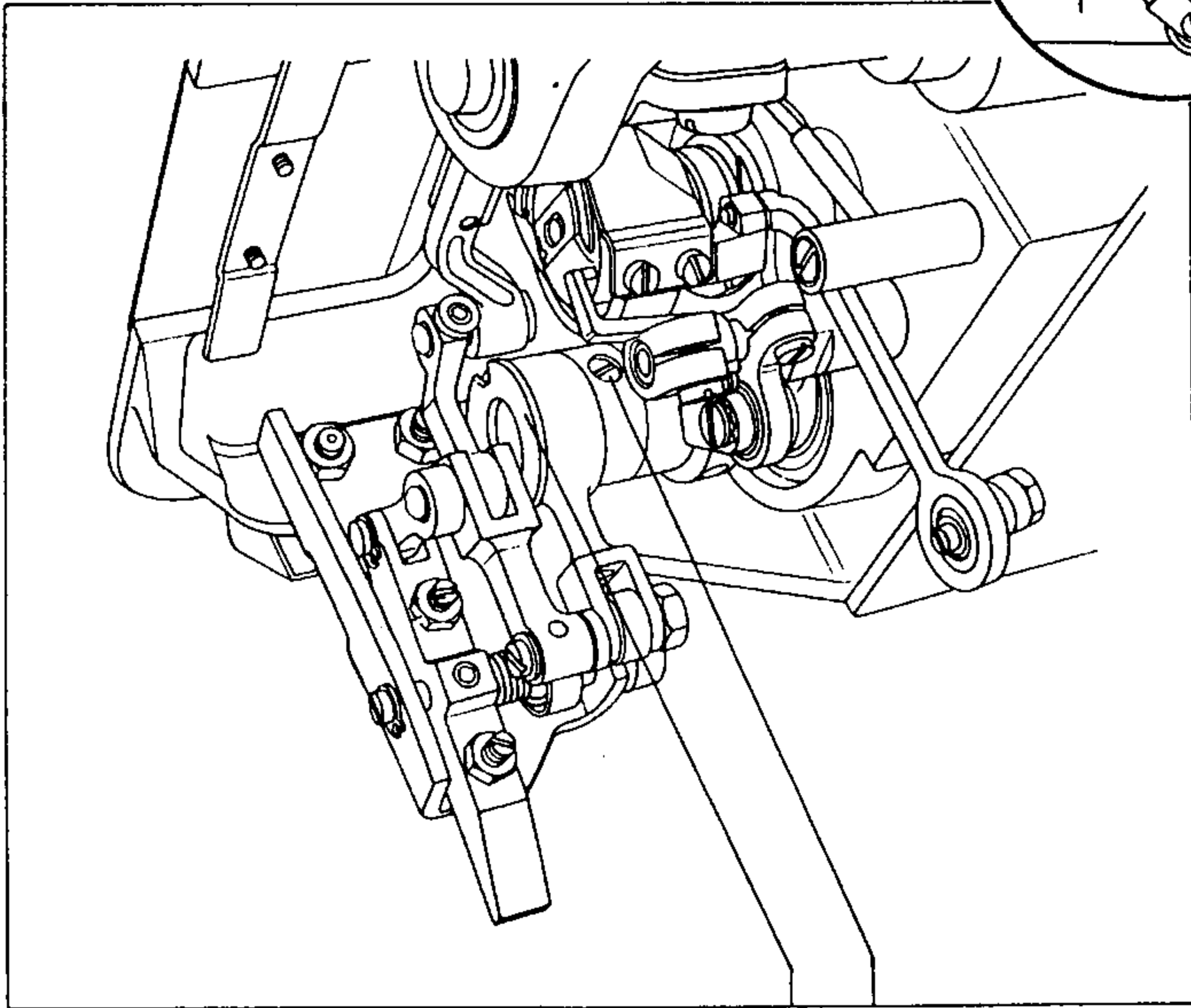

1

1

2

9 Fabric clearance

With the presser foot lifting lever raised, the fabric clearance must be 7 mm.

Lower the presser foot onto the needle bar.

Set the head of regulating screw 1 (Fig. 1) flush with the beginning of the screw thread in the sewing head.

Adjust a light pressure on the presser foot by turning screw 2 (Fig. 1) in or out, respectively.

Loosen screw 3 (Fig. 2) and push out bearing pin 4.

Swivel link 5 (Fig. 3) out of the yoke of driving lever 6.

Turn balance wheel to set vibrating presser 7 (Fig. 1) up and raise the presser foot by means of the lifting lever.

Lift presser bar 9 (Fig. 3) and place the 7-mm adjustment gauge under the presser foot hinge from the rear.

Loosen screw 10 (Fig. 2) and push out pin 11.

Loosen screw 12 (Fig. 1).

Adjust presser foot 8 (Fig. 1) so that its edge is parallel to the feed slots.

Move lifting piece 13 (Fig. 1) fully down and tighten screw 12.

Pins 4 and 11 (Fig. 2) are replaced in the following adjustment (see section 10).

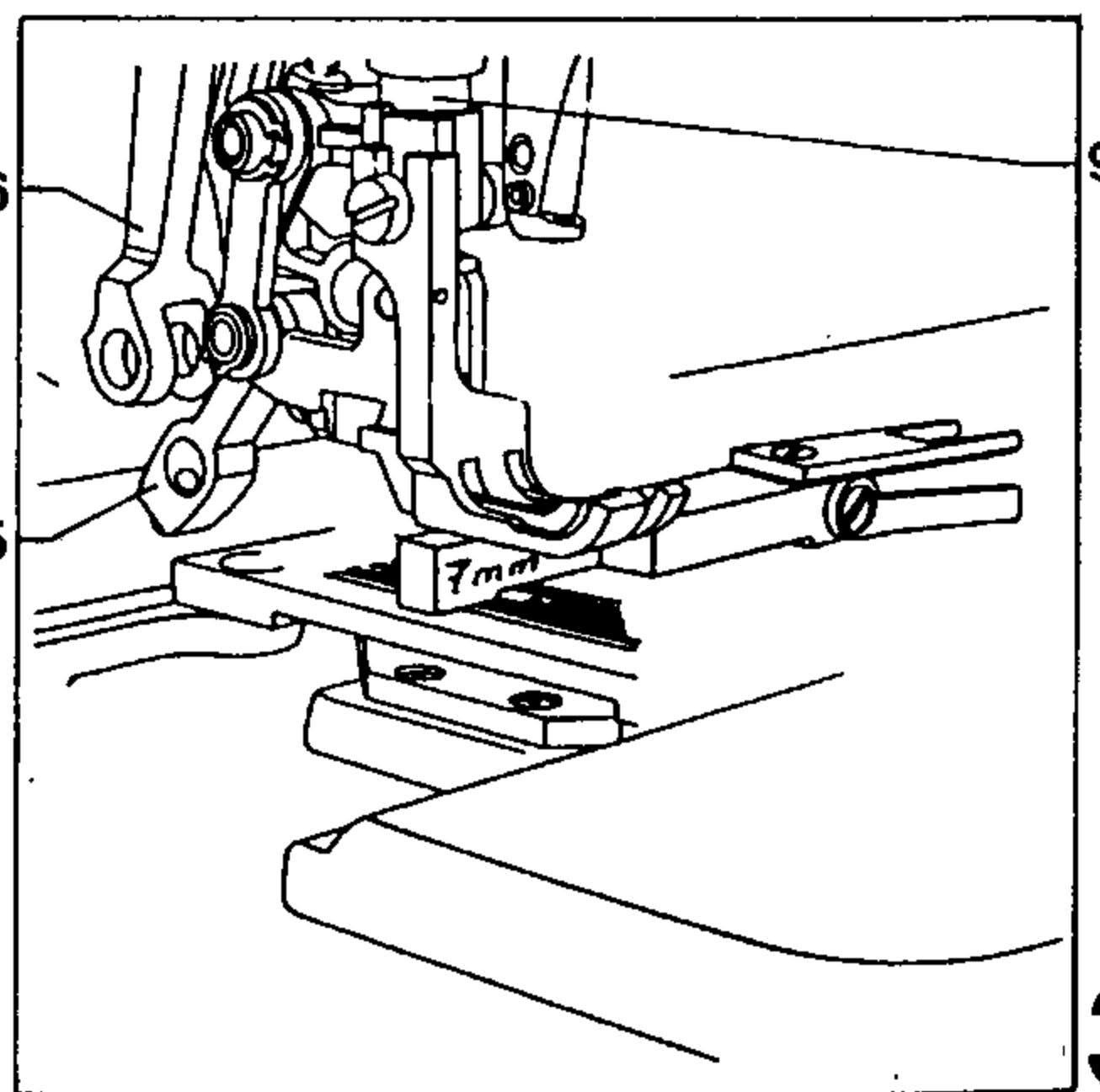
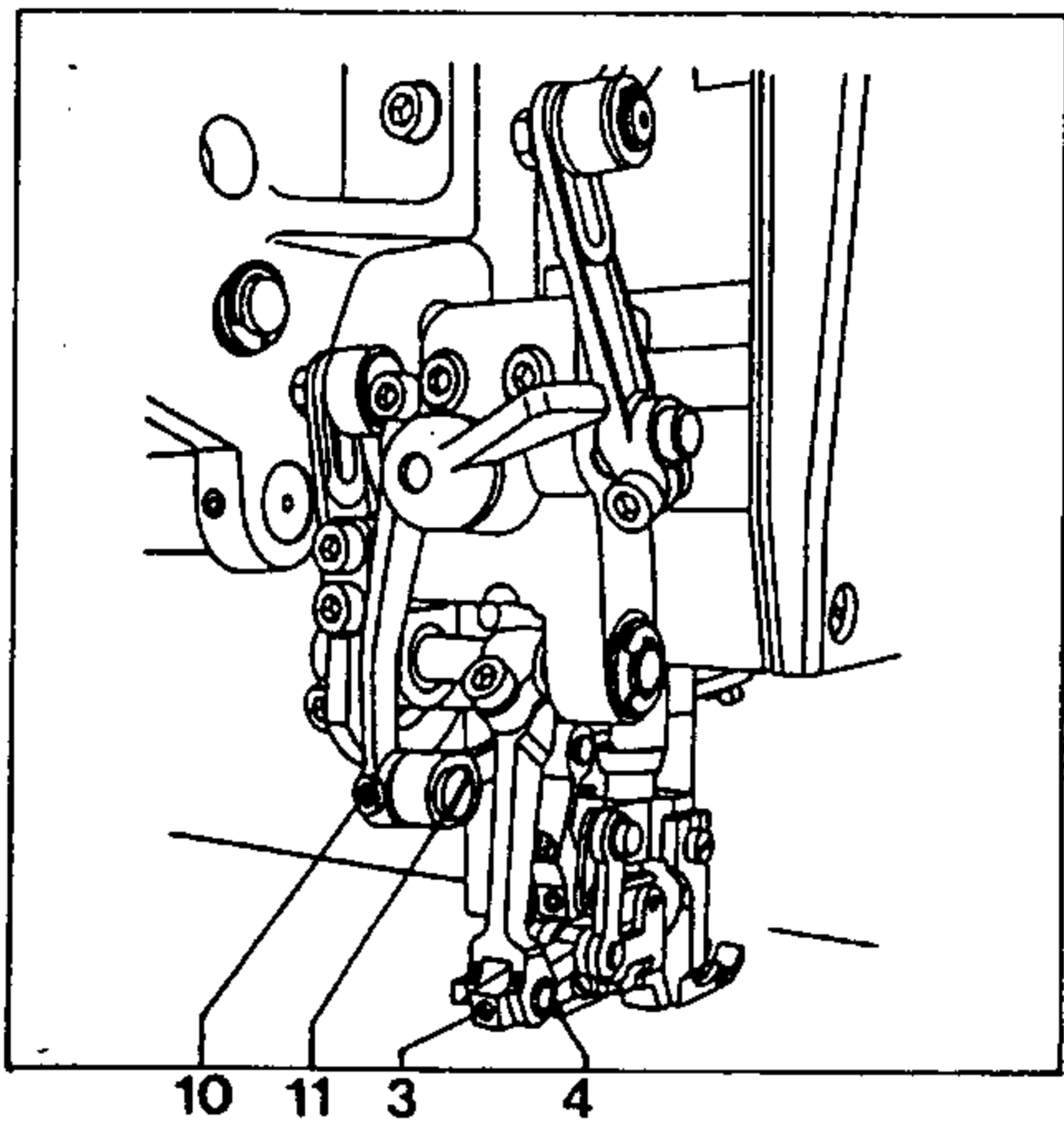
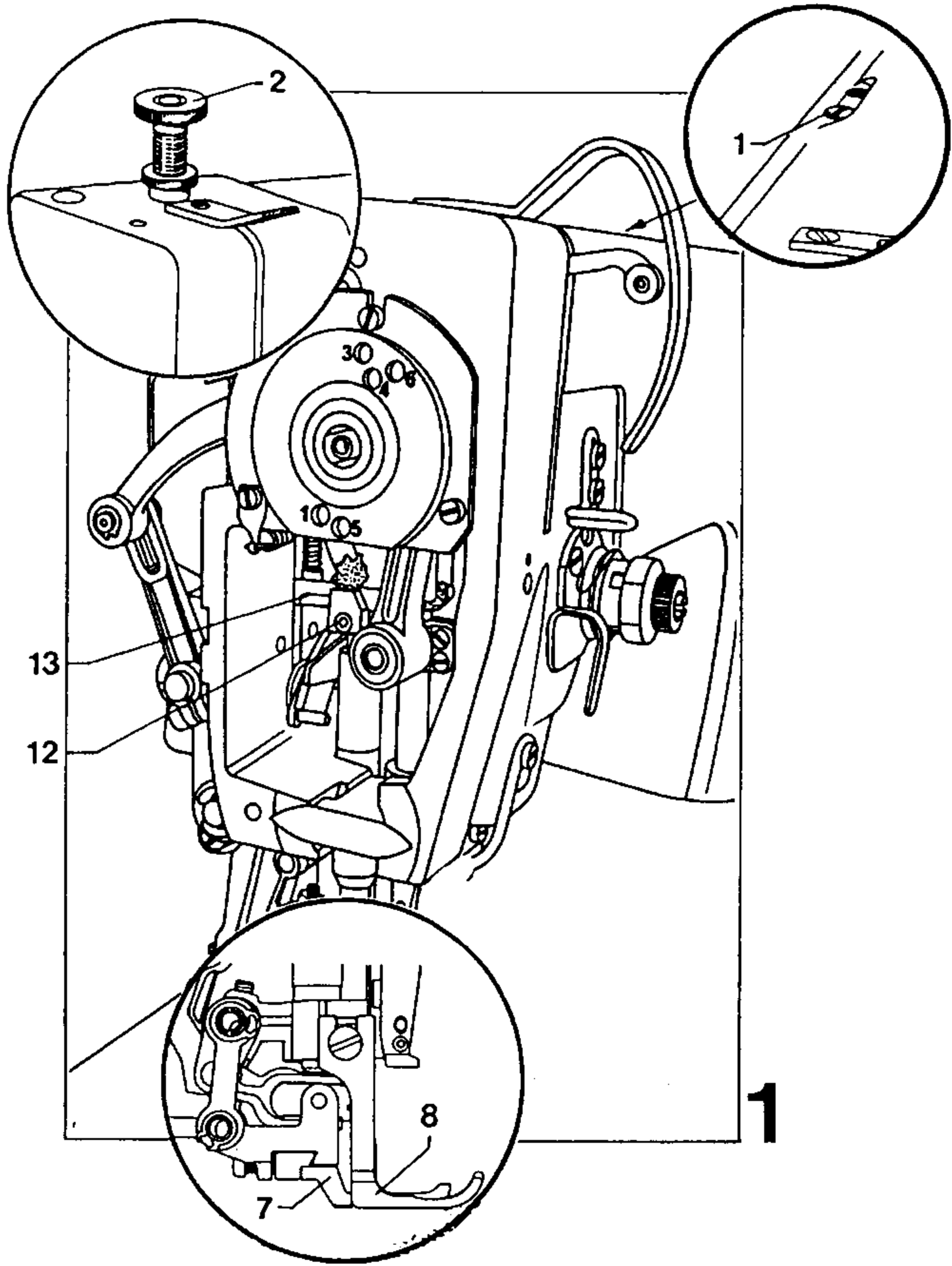

10 Top feed driving- and connecting lever

All moving parts of the top feed must move freely and without play.

Move lifting lever 1 (Fig. 1) down.

Loosen screw 2.

Swivel link 3 (Fig. 1.1) into the yoke of driving lever 4.

Push bearing pin 5 (Fig. 1.1) into driving lever 4 and through link 3; make sure this can be done easily and re-adjust driving lever 4, if necessary.

Set stitch length "0" at lever 6 (Fig. 2).

Set the vibrating presser central to the presser foot cutout as seen in sewing direction and tighten screw 2 (Fig. 1).

Check that bearing pin 5 and link 3 do not bind; re-adjust driving lever 4, if necessary.

Loosen screw 7 (Fig. 1).

Set the hole of linking lever 8 exactly opposite the hole of pull rod 9; if necessary, adjust linking lever 8 accordingly.

Push eccentric pin 10 through the hole of pull rod 9 into the hole of linking lever 8 in such a way that its lobe faces down.

Tighten screw 11.

Push linking lever 8 back (feed direction) until a stop is felt, and tighten screw 7.

Tighten screw 12.

Loosen screw 13.

Adjust the vibrating presser crosswise to sewing direction so that it does not contact the presser foot; in this position, tighten screw 13.

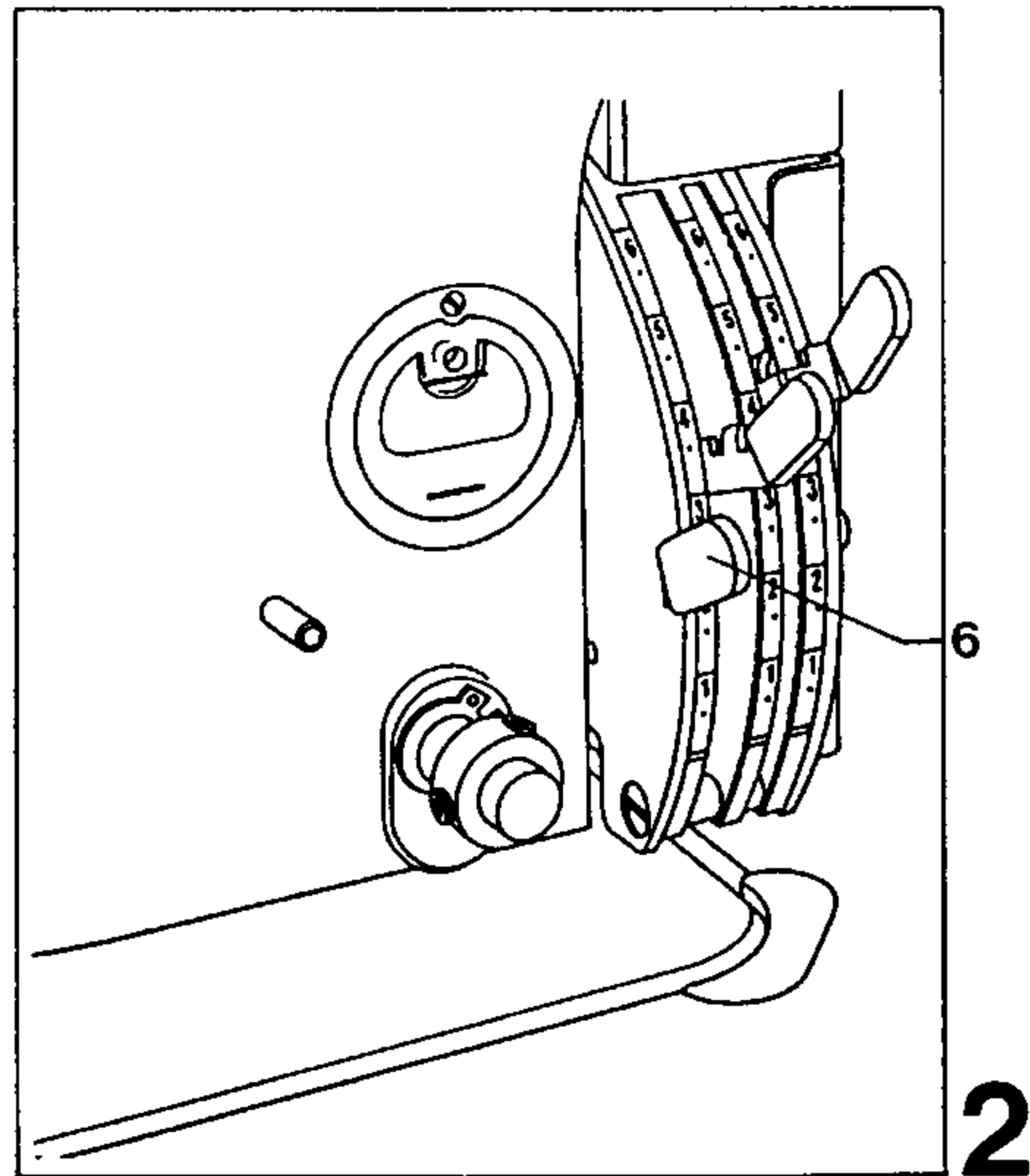
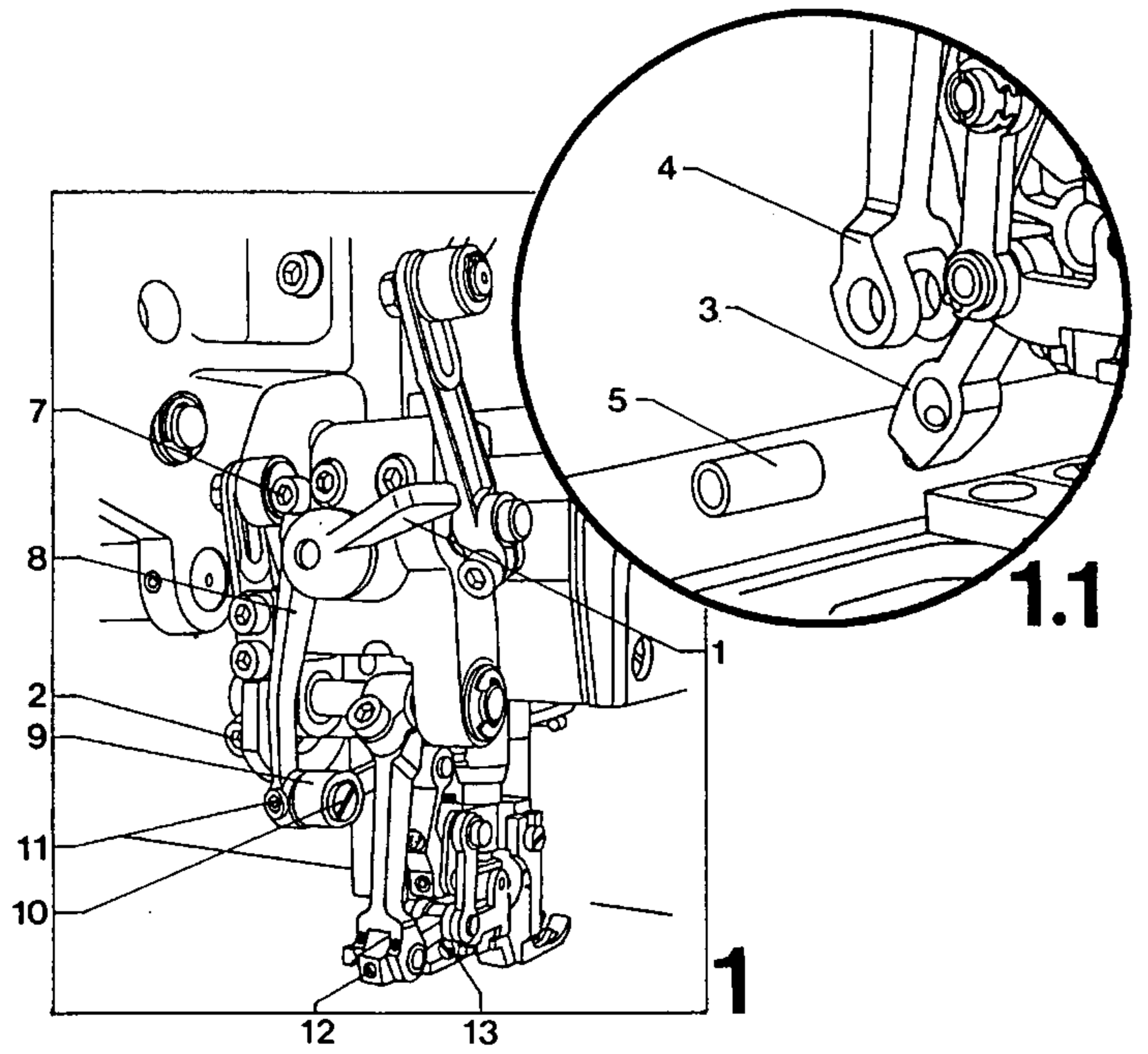

11 Neutralizing the top feed

With the stitch length and top feed stroke set at "0" and with adjustment link 1 (Fig. 1) attached, driving lever 2 (Fig. 2) must not move when the balance wheel is turned.

Remove link 3 (Fig. 3).

Attach adjustment link 1 (Fig. 1).

Loosen screws 4 (Fig. 1), 5 and 6 (Fig. 3), as well as nut 7 (Fig. 2).

Set feed regulating lever 8 (Fig. 4) at "0".

Loosen screw 16 (Fig. 2) and push out bearing pin 17.

Unscrew upper part of the belt guard.

Move pull rod 9 repeatedly up and down in the elongated hole of lever 10 (Fig. 2); driving lever 2 must then remain motionless.

For correction, loosen screw 11 (Fig. 5) (always tighten it when checking the adjustment); re-position lever 10 (Fig. 2) so that with screw 11 (Fig. 5) tightened, driving lever 2 does not move when pull rod 9 (Fig. 2) is moved up and down.

Push pull rod 9 to the top of the elongated hole in lever 10 and tighten hexagon nut 7.

Set feed regulating lever 8 (Fig. 4) at "3".

Loosen screw 12 (Fig. 1), set the leg of crank 13 parallel to the base plate and tighten screw 12 again.

Set feed regulating lever 8 (Fig. 4) at "0".

Loosen screw 14 (Fig. 6) and turn feed regulating lever 15 so that driving lever 2 (Fig. 2) remains motionless when the balance wheel is turned; tighten screw 14 (Fig. 6).

Insert pin 17 (Fig. 2) in driving lever 2 and linkage 18; tighten screw 16.

Set stitch length "4.5" at feed regulating lever 8 (Fig. 4).

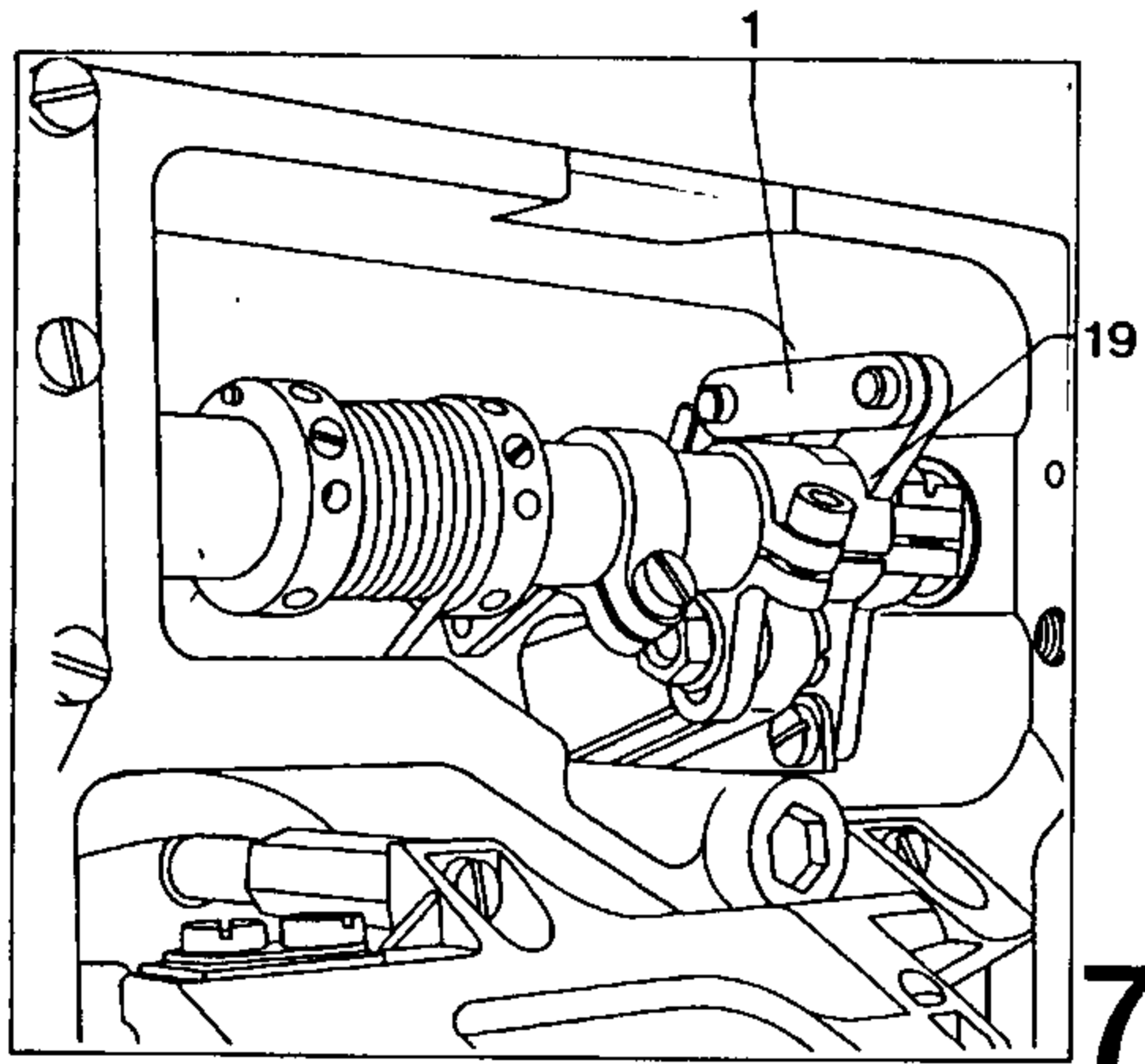

7

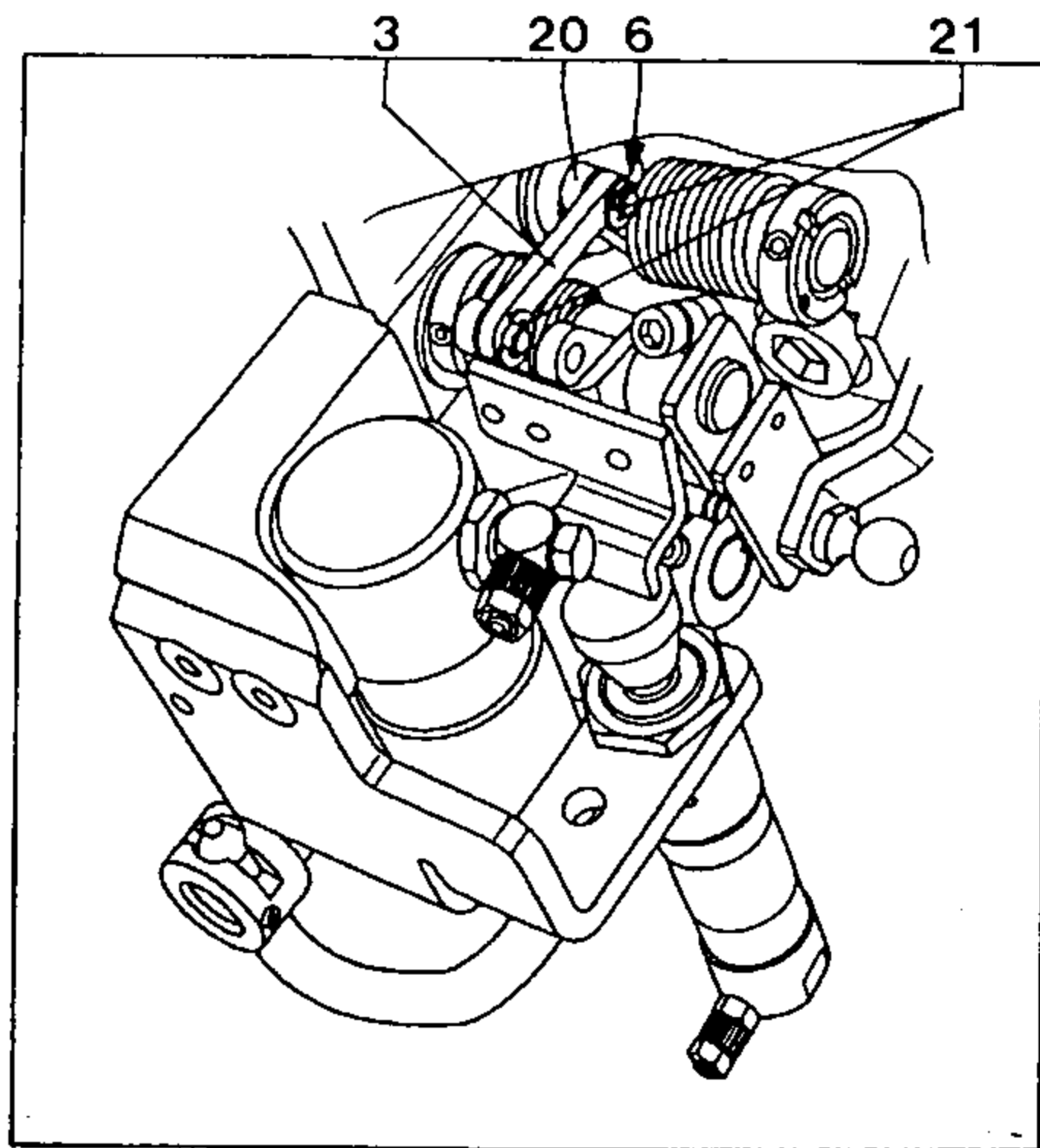

8

12 **Automatic backtacking mechanism**

When cylinder 1 (Fig. 1) is extended, the machine must sew in reverse.

Push link 2 (Fig. 2) on pins 3.

Set stitch length at 3 mm.

Loosen clamp screw of crank 4 (Fig. 1) and rest crank against bracket 5. Make sure that bracket 5 rests against crank 6.

In this position, tighten the clamp screw of crank 4.

Loosen screw 7, rest crank 8 against bracket 9, and tighten screw 7 again.

Remove link 2 (Fig. 2).

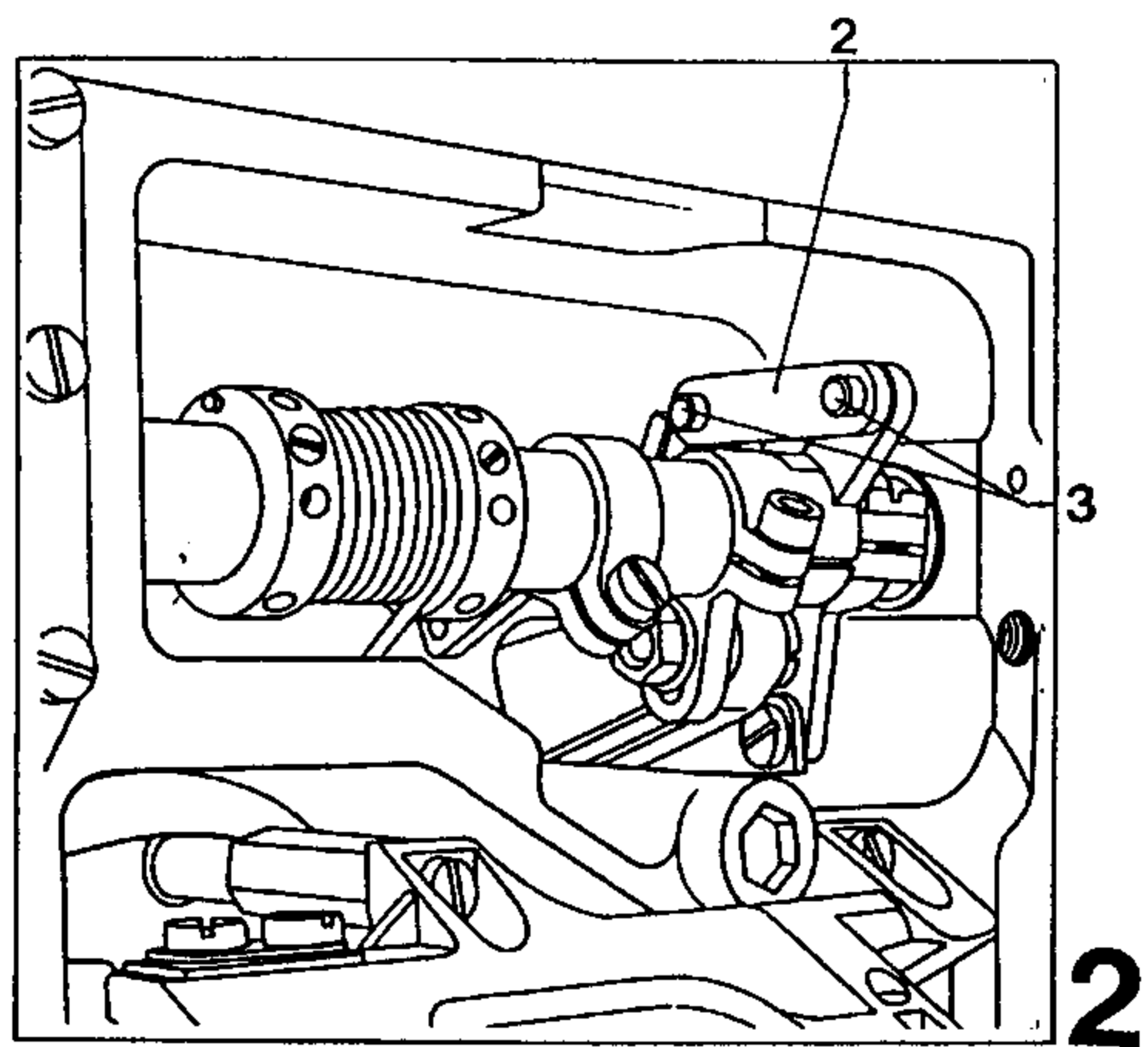
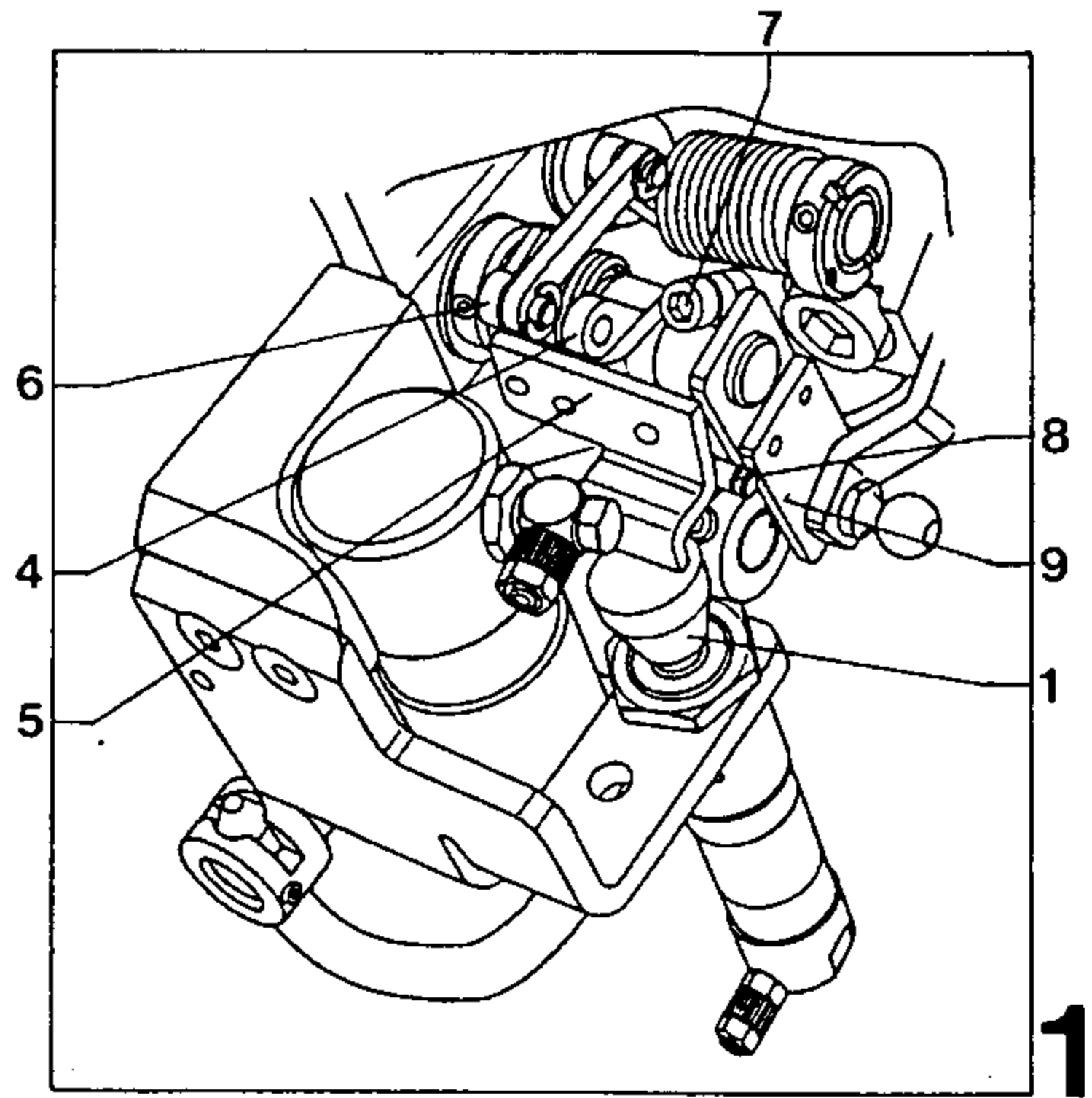

13 Top feed advancing motion

With the stitch length set at "4.5 mm" and the needle bar 0.6 mm past t.d.c. (= adjustment hole "1"), the vibrating presser must remain motionless when the shaft of the reverse feed control is turned.

Set stitch length "4.5 mm" at feed regulating lever 1 (Fig. 1).

Raise the presser foot.

Loosen screws 2 (Fig. 2).

Set needle bar 0.6 mm past t.d.c. and insert adjustment pin in hole "1".

Insert an allen key in the clamp screw of fixing collar 3 (Fig. 1).

While moving the allen key to and fro, turn feed driving eccentric 4 (Fig. 2) (cutout 5 must face to the front of the machine) so that vibrating presser 6 (Fig. 3) remains motionless.

Tighten the accessible screw (Fig. 2).

Remove adjustment pin and allen key.

Tighten the second screw 2.

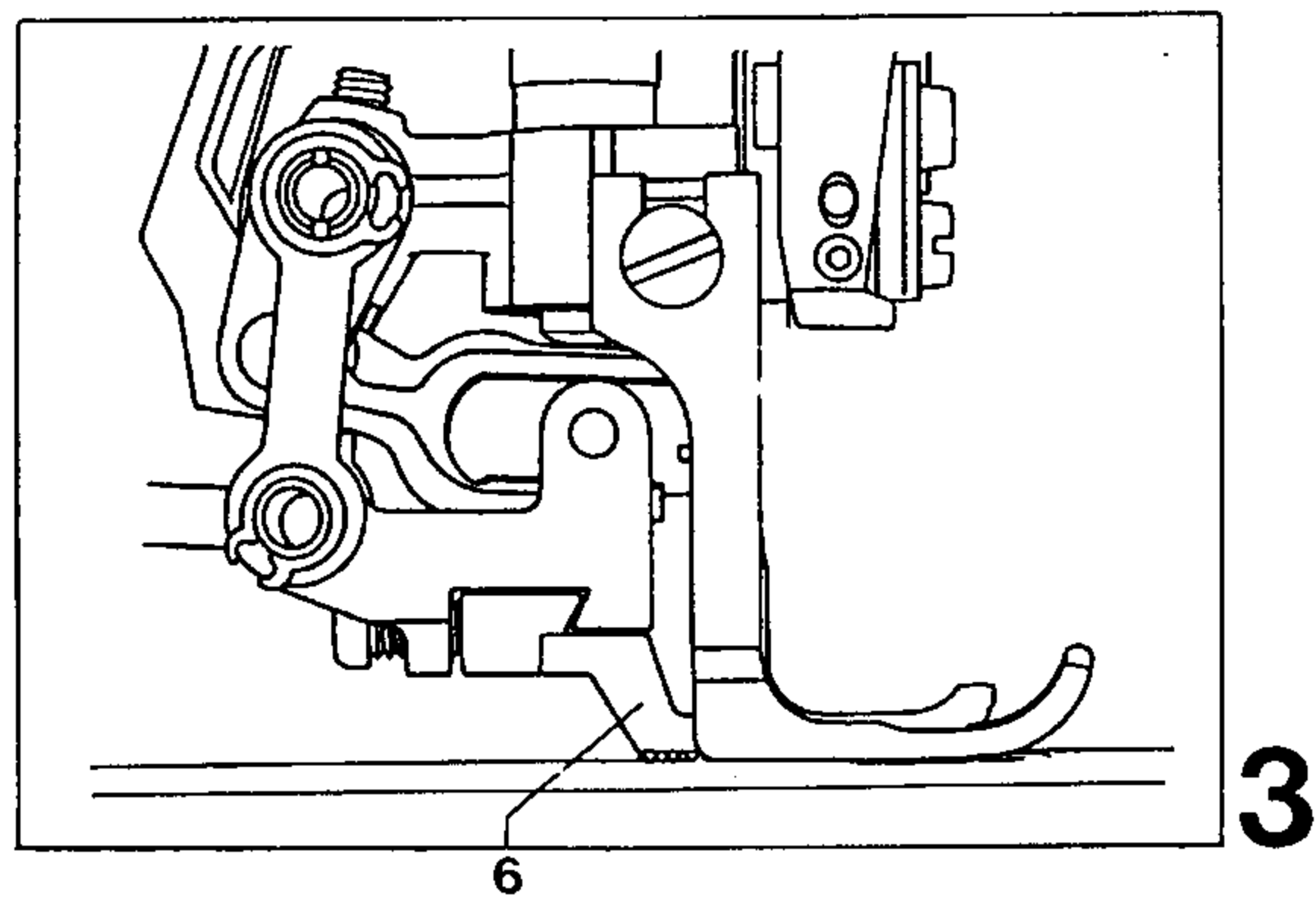
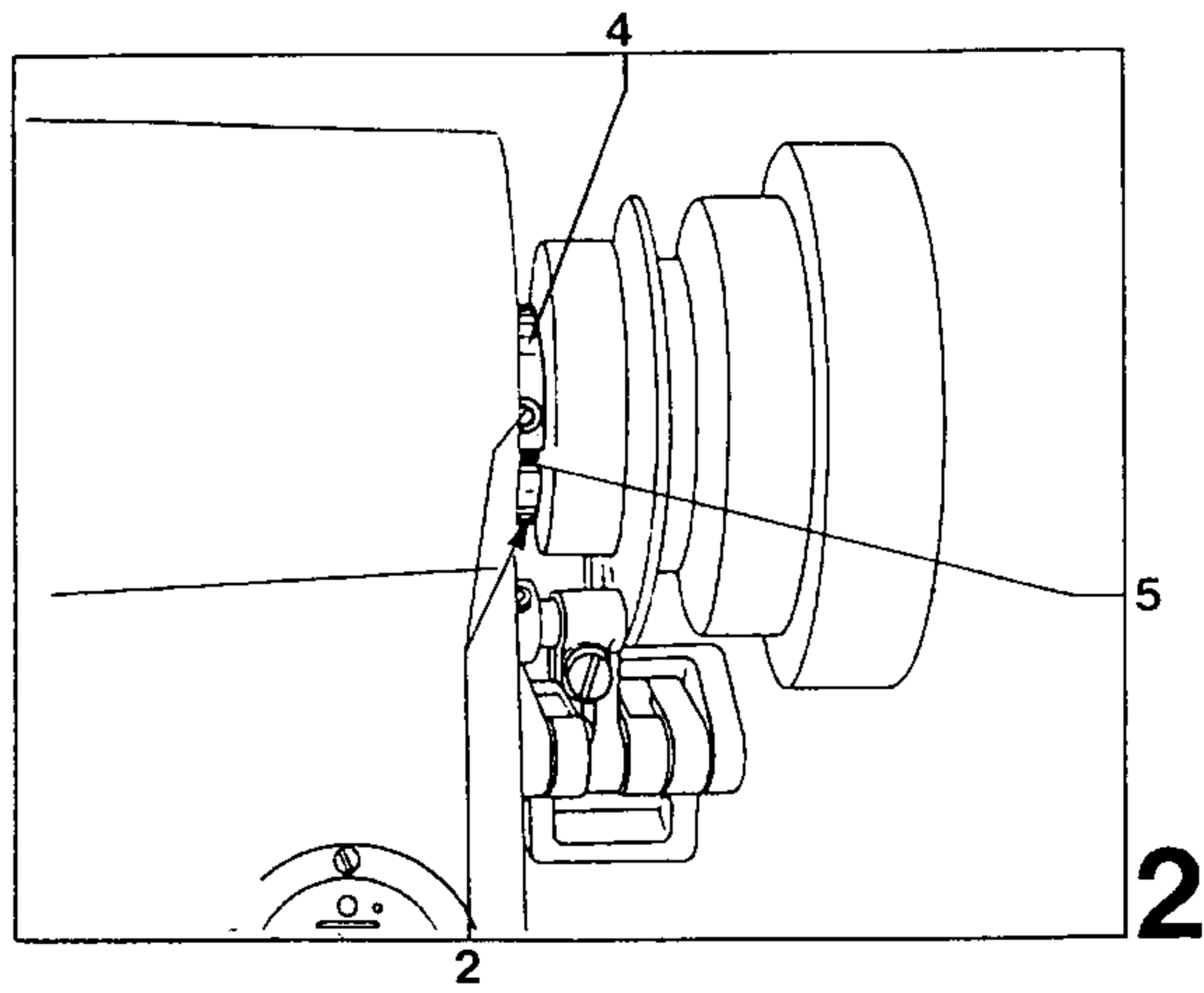
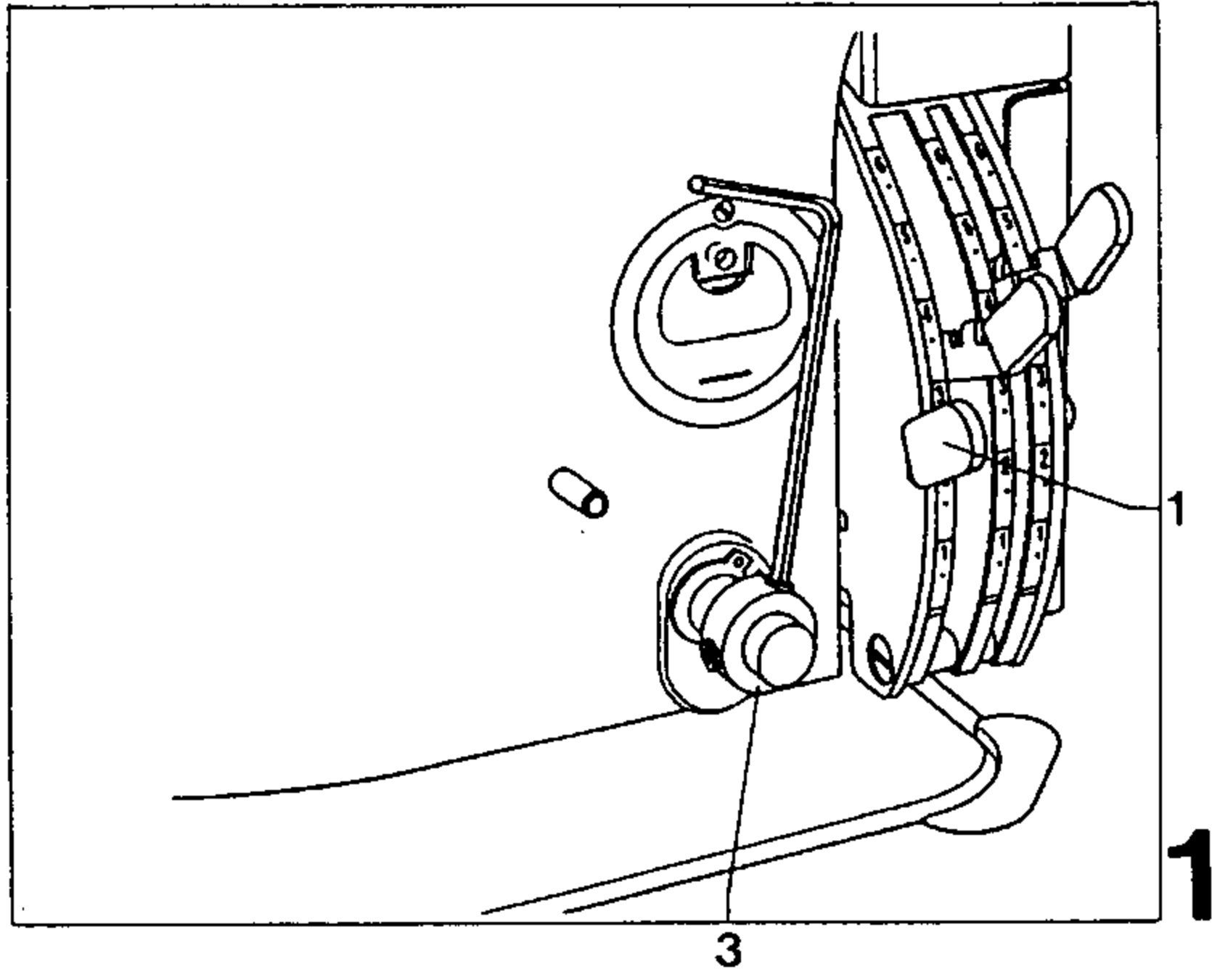

14 Top feed lifting motion

With the stitch length set at "4", the vibrating presser must contact the bottom feed dog when the latter in its upward movement has reached the needle plate surface.

Set stitch length at "4".

Rest presser foot on needle plate.

Set the take-up lever up and loosen screw 1 (Fig. 1), accessible from below.

Turn eccentric pin 2 so that the vibrating presser does not contact the bottom feed dog until the latter in its upward movement has reached the needle plate surface.

Tighten screw 1.

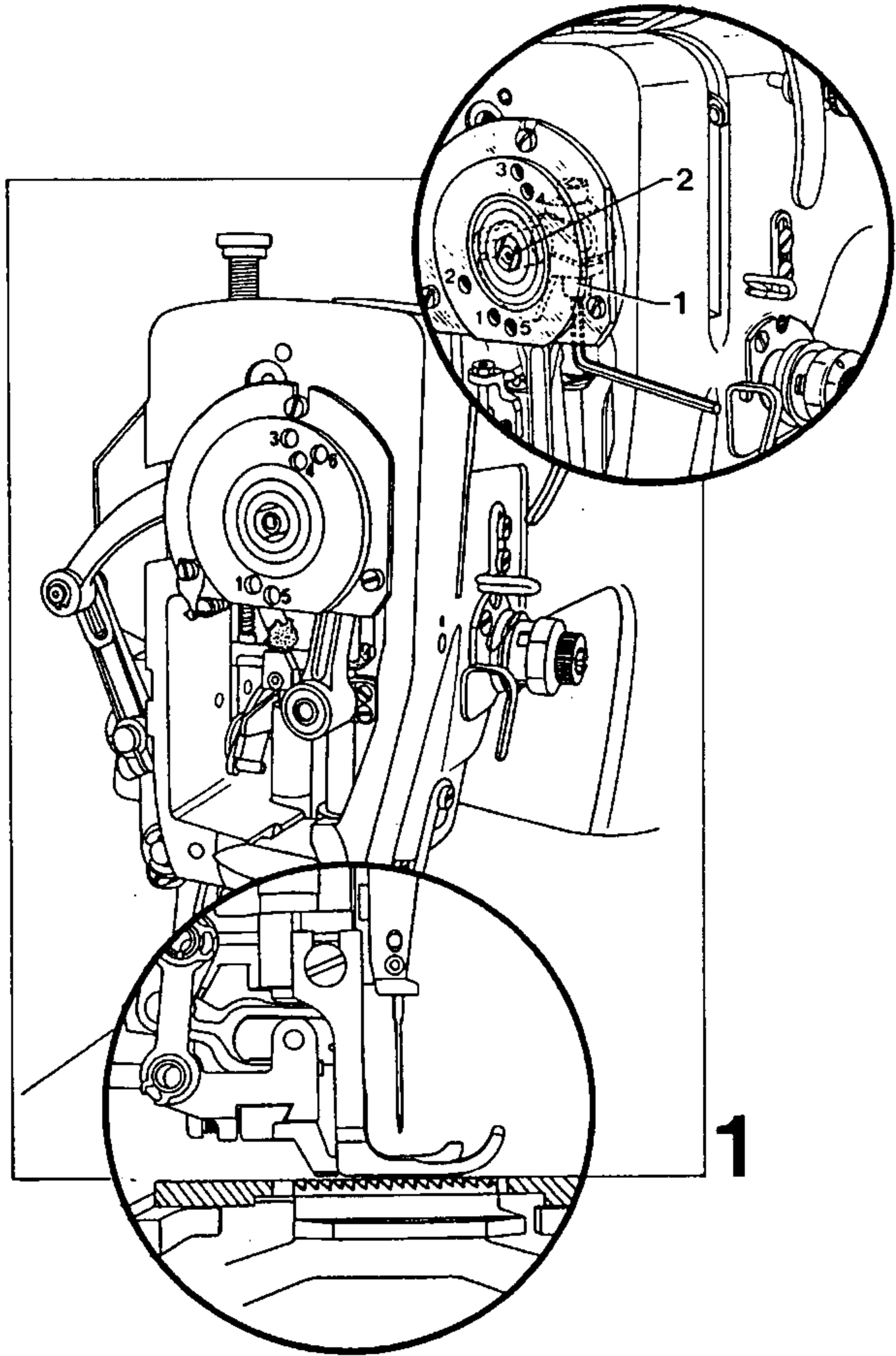

15 Top feed lift

With the presser foot resting on the needle plate and the vibrating presser at its top reversal point, there must be a clearance of 2 mm between needle plate and vibrating presser (in the area in front of the needle hole) when the stitch length is set at "0".

Attach link 1 (Fig. 1).

Set stitch length at "0".

Turn threaded sleeve 2 (Fig. 2) to increase the pressure on the presser foot a little.

Rest the presser foot on the needle plate.*

Loosen screw 3, move the lobe of pin 4 so that it faces the needle bar and tighten screw 3 again.

Turn balance wheel until linking lever 5 is at its rear point of reversal.

Carefully loosen screw 6 and push linking lever 5 back so that the respective feeler gauge can be inserted between vibrating presser and needle plate.

Push the 2-mm-thick feeler gauge under the vibrating presser from the front (in the area in front of the needle hole) and tighten screw 6.

Remove the feeler gauge.

If re-adjustment is necessary, loosen screw 7, turn eccentric pin accordingly and tighten screw 7 again.

Remove link 1 (Fig. 1).

* We recommend the use of gauge foot 61-111 639-20 for the adjustment.

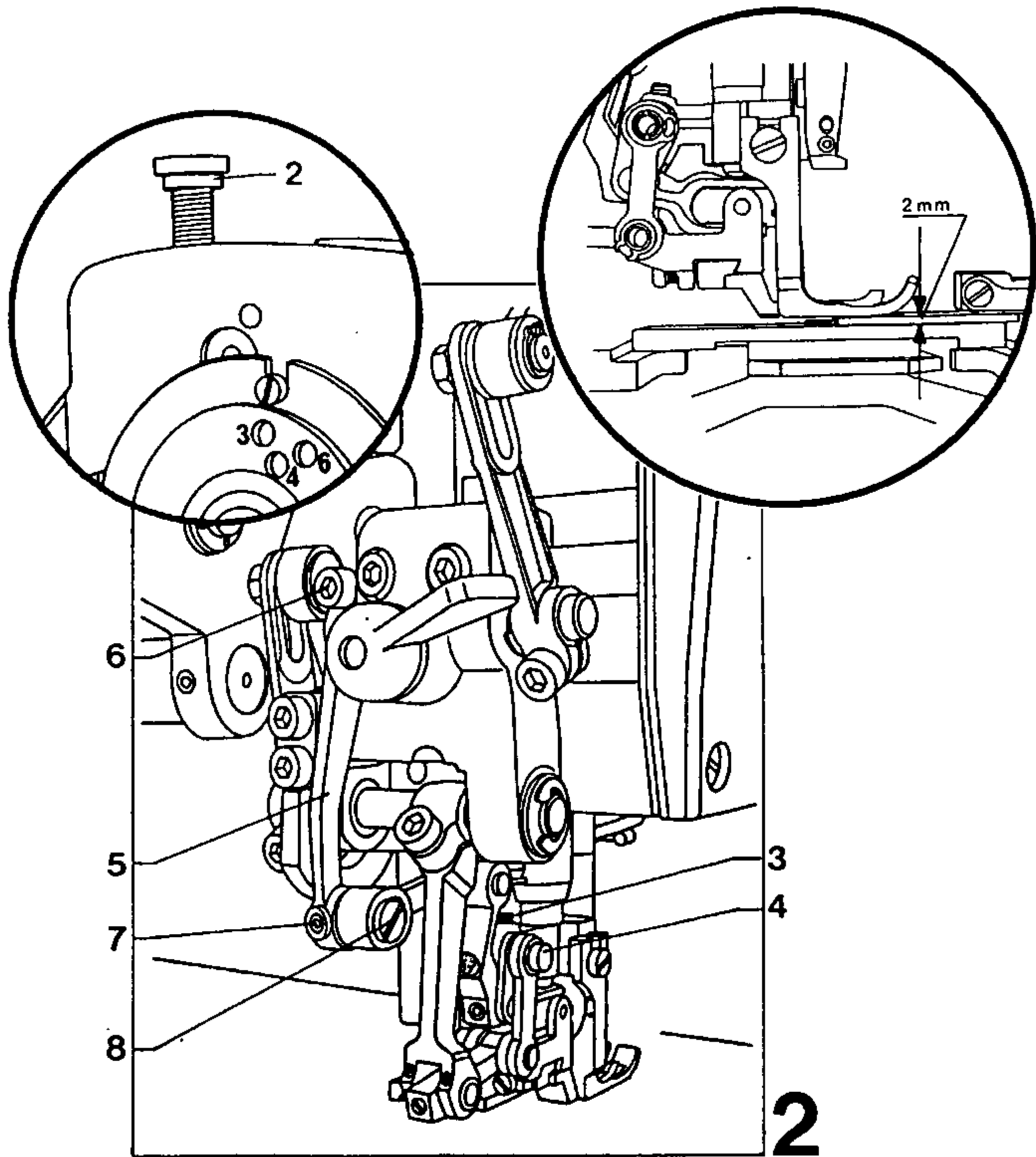
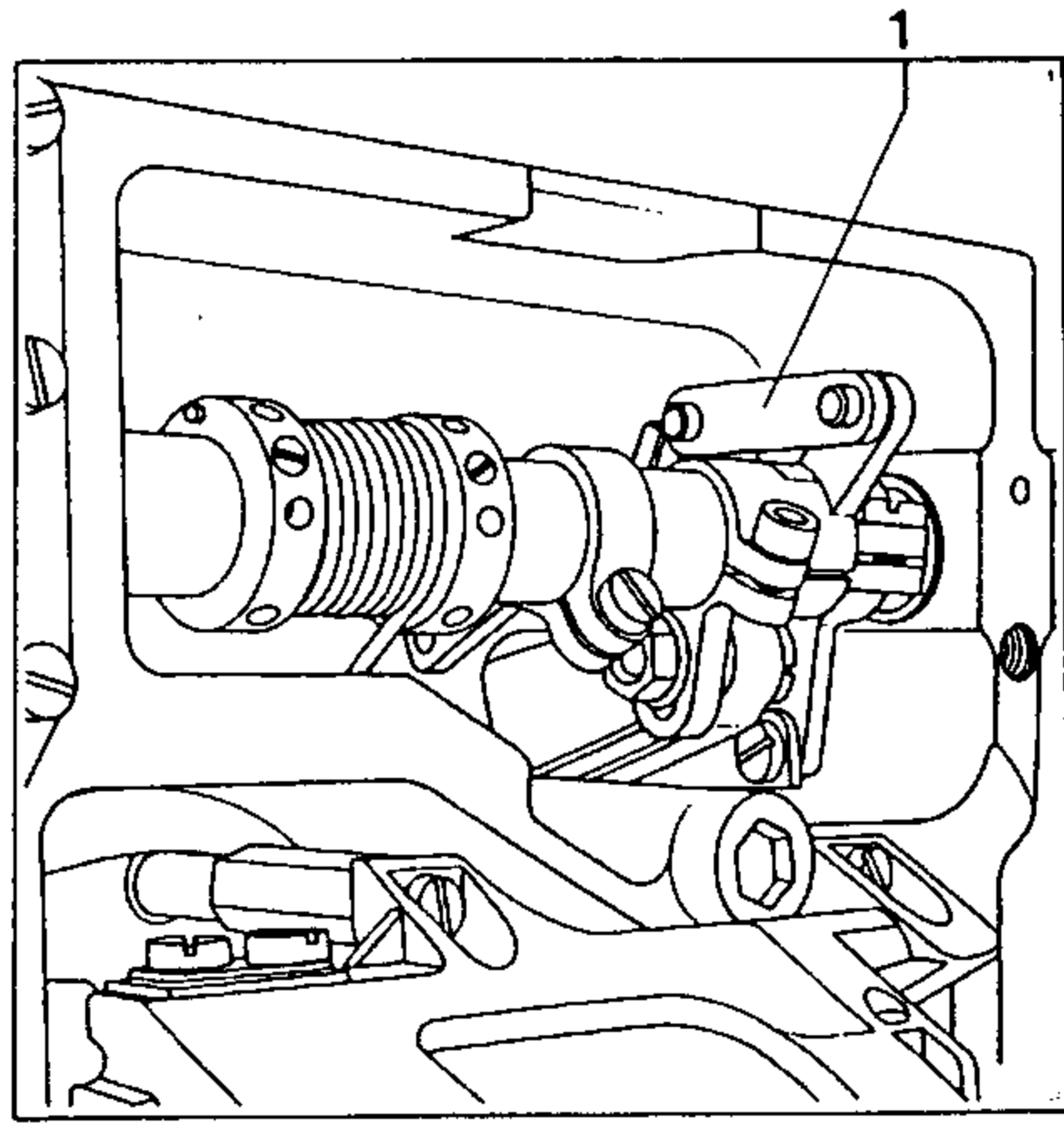

16 Position of vibrating presser

When the bottom feed dog is at its top reversal point, the vibrating presser must be parallel to the bottom feed dog.

Turn balance wheel to set the bottom feed dog at its highest position.

Rest the presser foot on the needle plate.

Loosen screw 1 (Fig. 1).

Turn the eccentric pin (see arrow in Fig. 1) so that the vibrating presser is parallel to the bottom feed dog when the latter is at its top point of reversal.

Tighten screw 1.

Check the top feed lift (section 15) and re-adjust, if necessary.

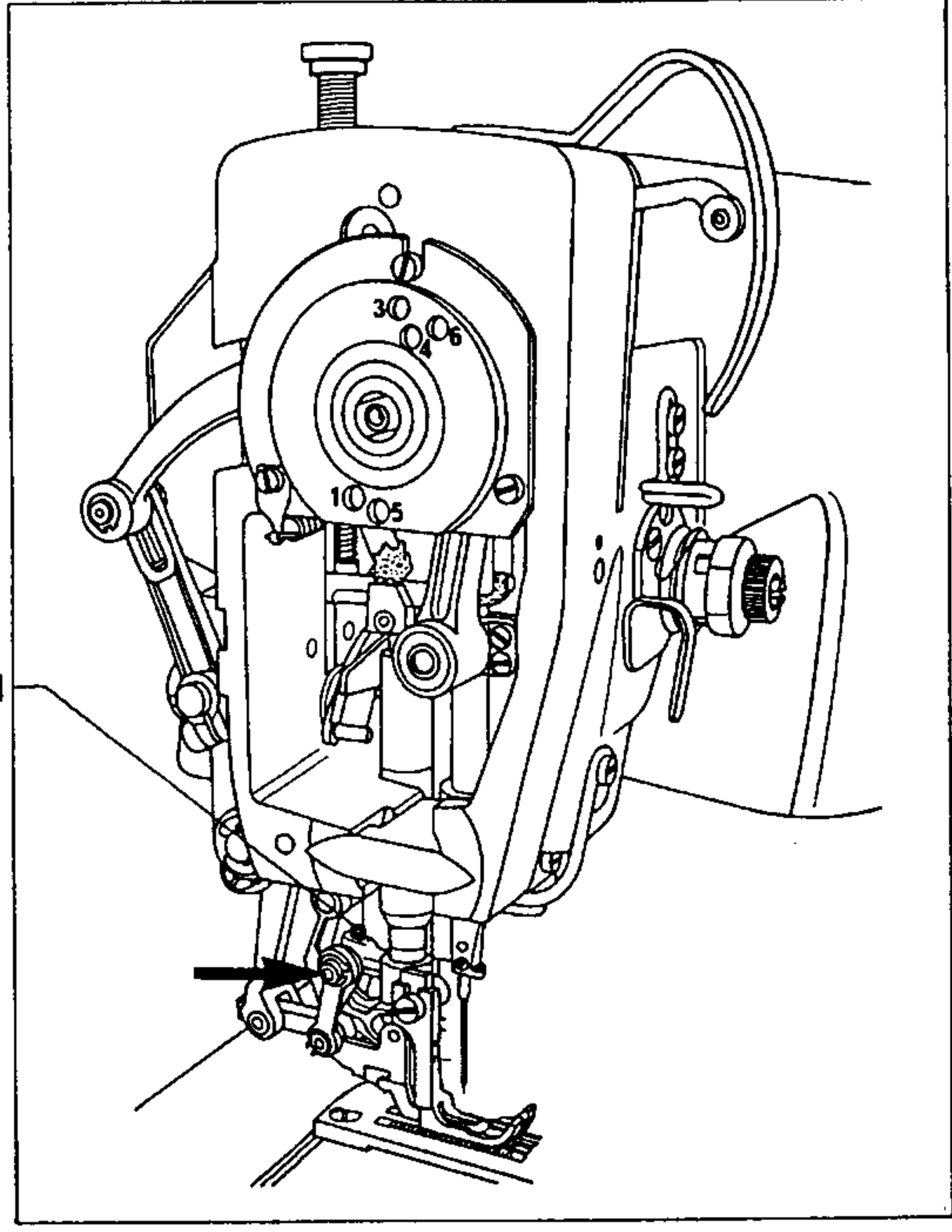

1

17 Synchronisation of top- and bottom feed

With the regulating levers for stitch length and top feed stroke set at "3", vibrating presser and bottom feed dog must make the same feed strokes when the balance wheel is turned.

Set the regulating levers for stitch length and top feed stroke at "3", making sure the adjustments in section 6.1 or 6.2 have been made.

Insert an allen key in the clamp screw of fixing collar 1 (Fig. 1).

By means of the allen key, turn reverse feed control shaft 2 as far as it will go in the direction of the arrow and loosen nut 3 (Fig. 2) which has thus become accessible.

Re-position pivot screw 4 in its elongated hole in such a way that vibrating presser and bottom feed dog make feed strokes of the same length when the balance wheel is turned.

Tighten nut 3.

Note:

The stroke of the vibrating presser can be increased by moving pull rod 5 (Fig. 3) down.

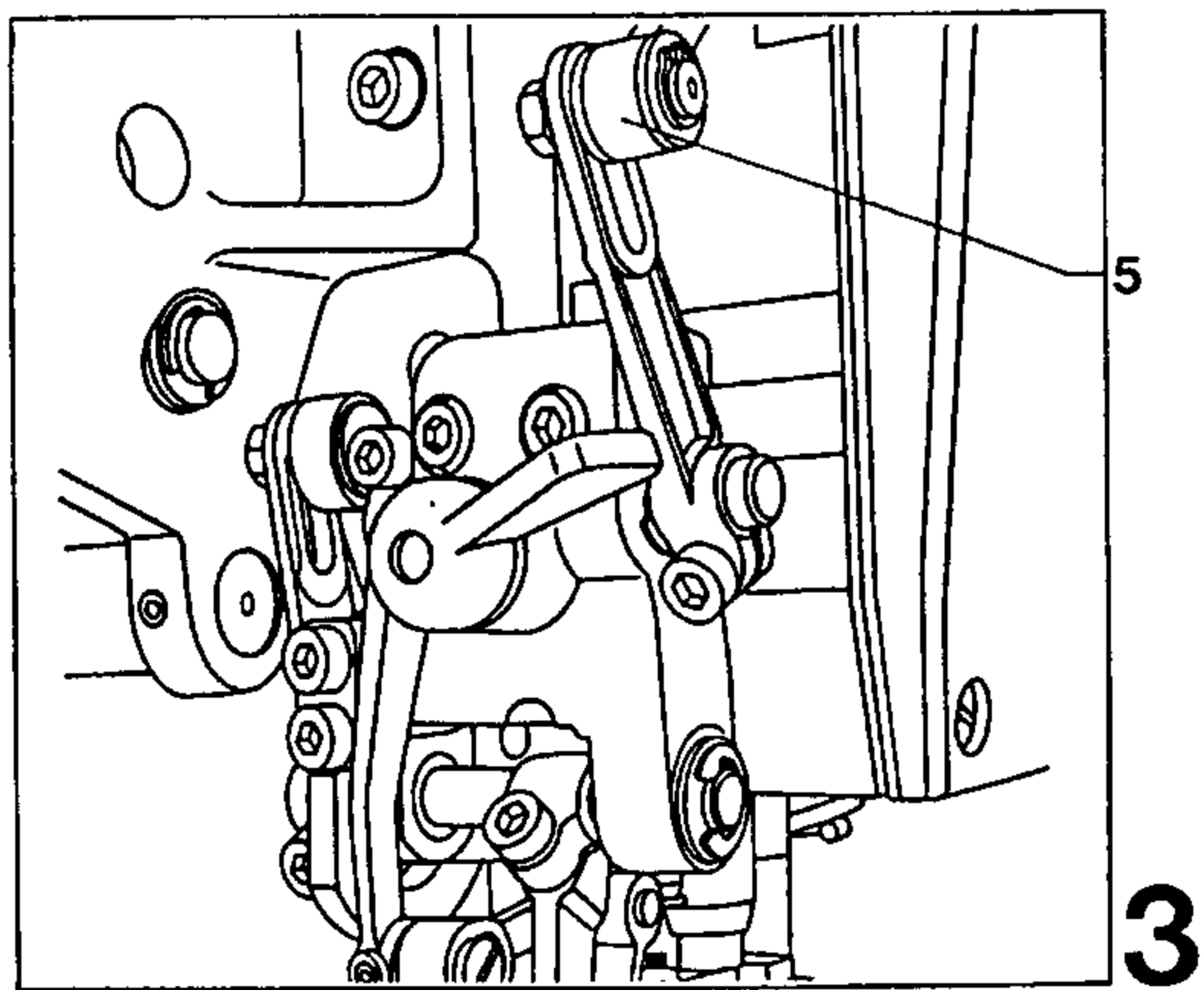
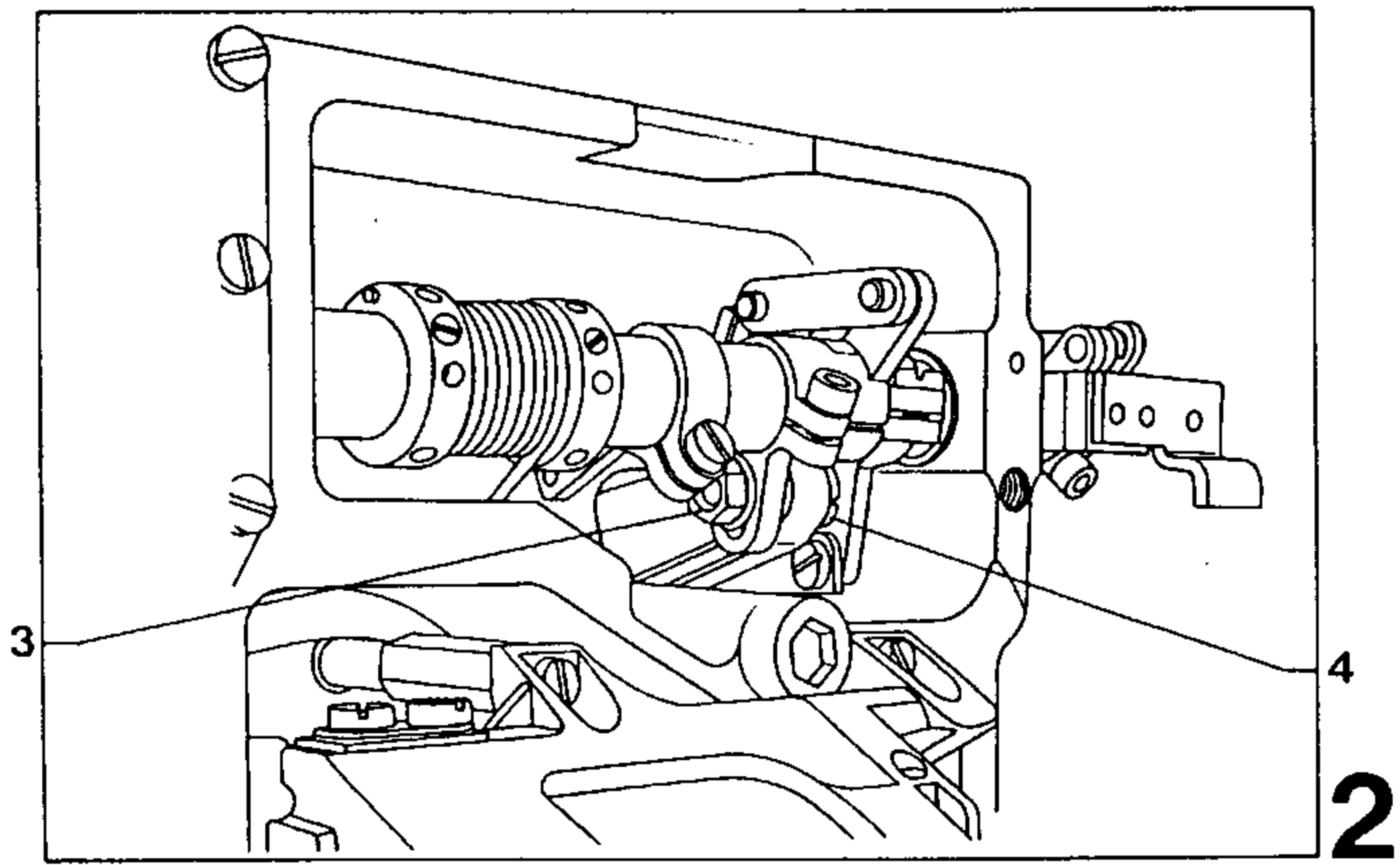
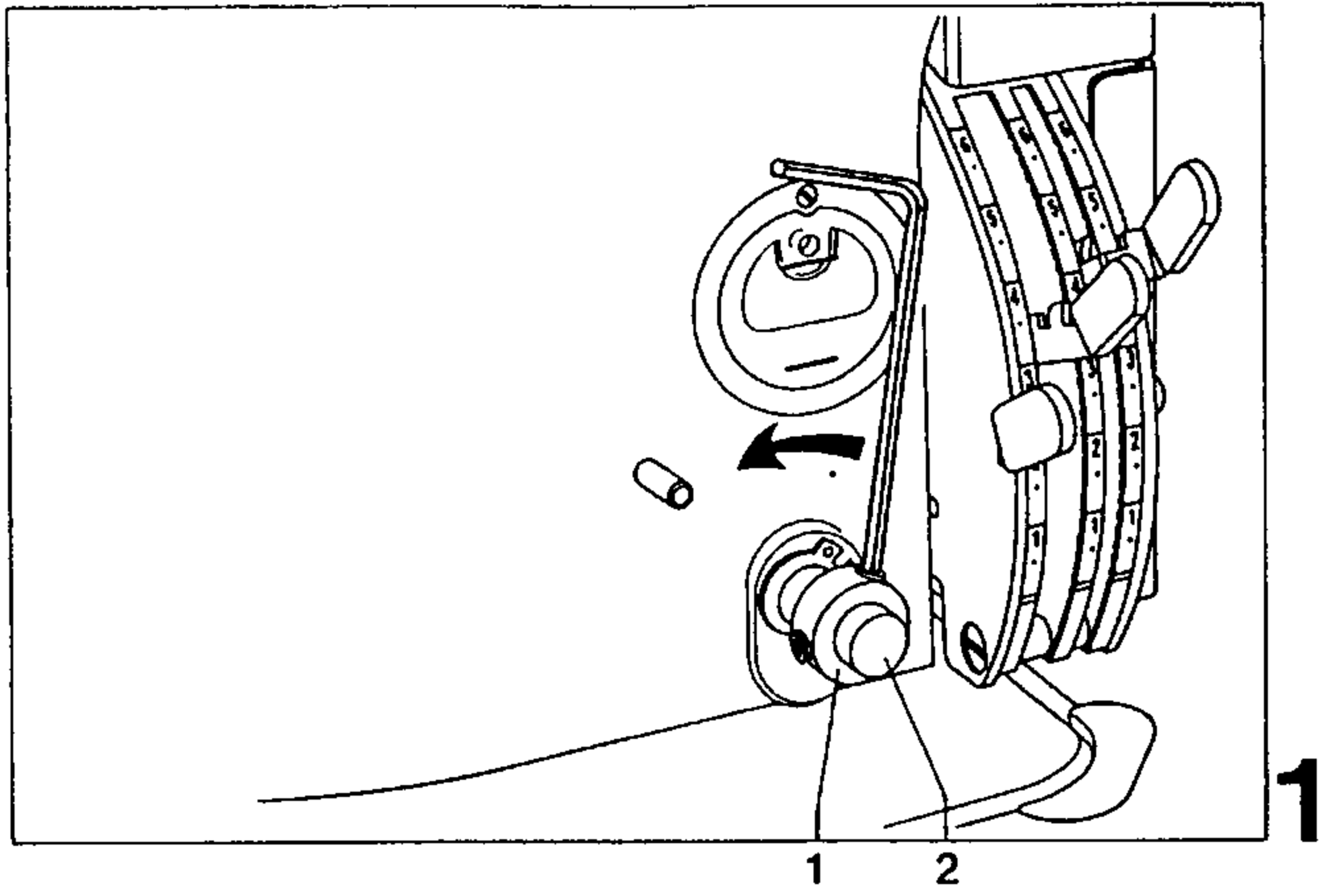

18 Synchronisation of top- and bottom feed in reverse sewing

The feed strokes of vibrating presser and bottom feed dog must be of the same length when sewing in reverse.

Loosen screw 1 (Fig. 1).

Re-position lever 2 accordingly.

Tighten screw 1.

Turn balance wheel while watching the feed strokes.

Repeat the adjustment, if necessary.

18.1 Limitation of feed regulator for backtacking

Set feed regulating lever at "4.5". Rest lever 3 (Fig. 2) against the upper regulating shaft from below.

Tighten screw 4.

18.2 Limitation of feed regulator for stitch condensation

Set feed regulating lever at "1" to "1.5". Rest lever 3 (Fig. 2) against the upper regulating shaft from above.

Tighten screw 4.

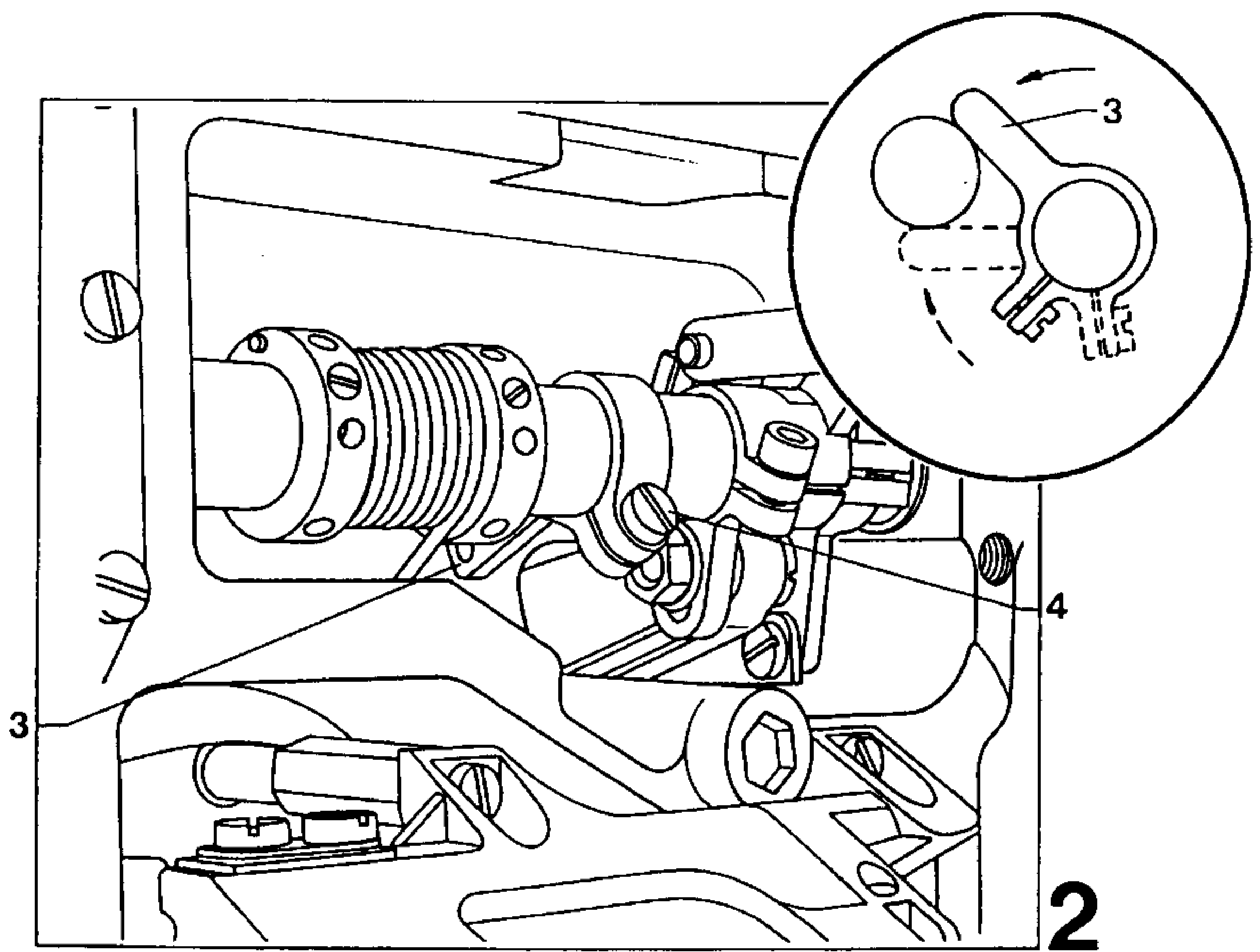
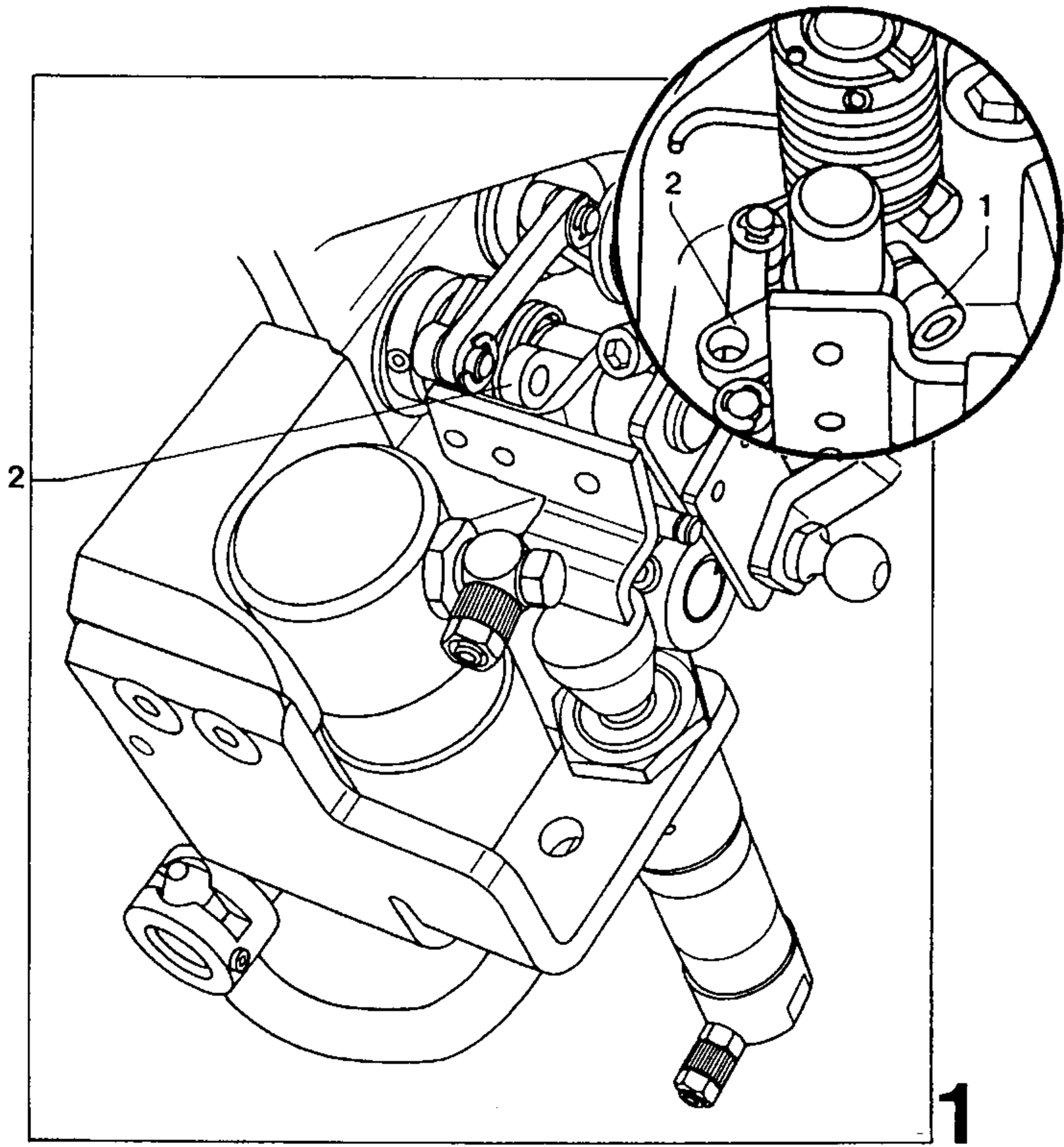

19 **Stitch length adaption**

When the stitch length is set at "3", the stitches must be of the same length in forward and reverse sewing.

Set stitch length at "3".

Loosen screw 1.

Set the lobe of bush 2 so that it faces down; then turn the bush a little forward or back, as required, until the stitches are of the same length in forward and reverse sewing.

Tighten screw 1.

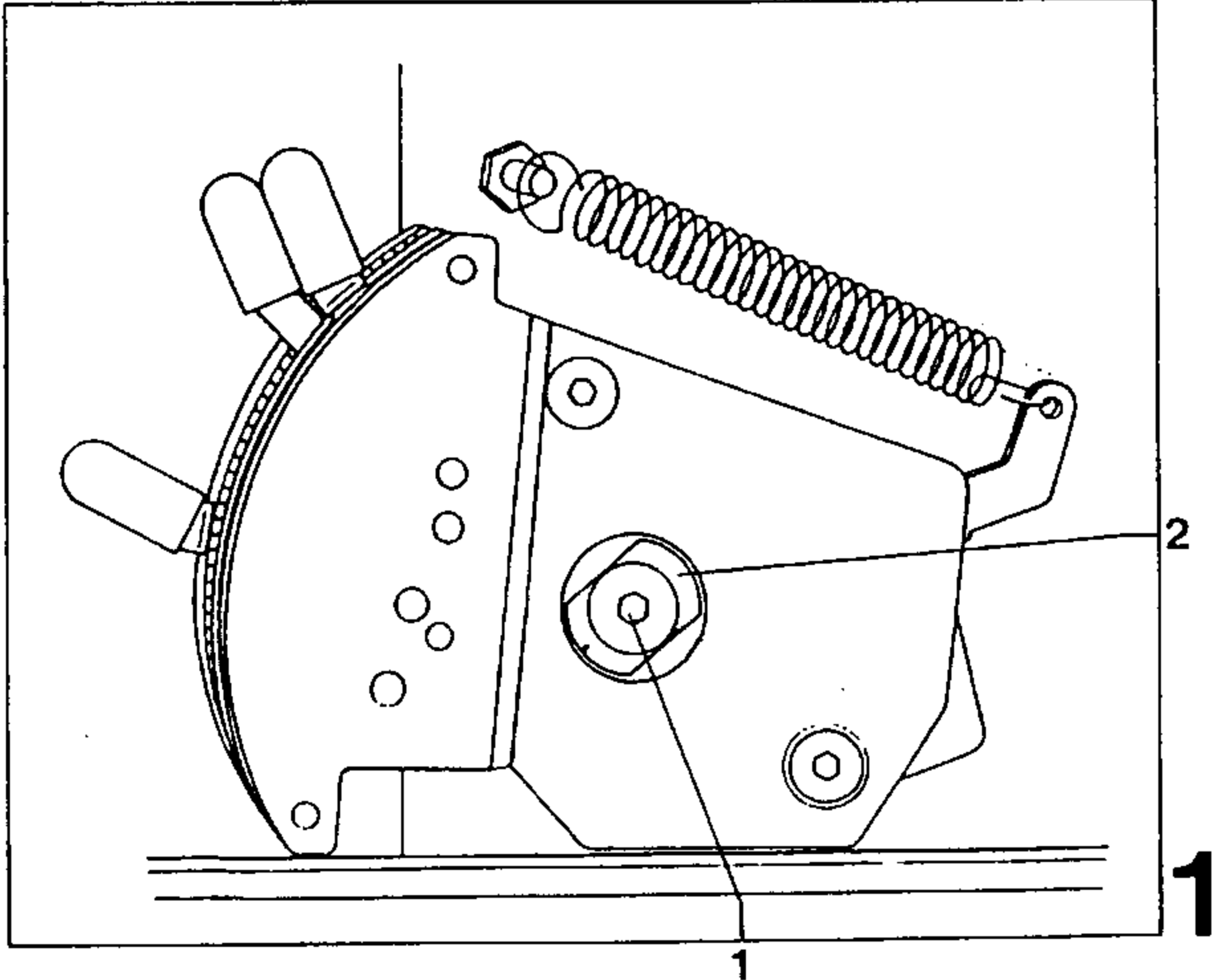

20 Eccentric hook shaft bearing

When the sewing hook is in contact with oil thrower 1 (Fig. 1), there must be a clearance of 0.4 mm between the hook point and the center of the clearance cut of the needle. The gears must have a barely perceivable backlash.

Loosen screw 2 and swivel oil tube 3 out of oil thrower 1.

Loosen screw 4.

Turn eccentric bearing 5 so that the groove is visible from below (see arrow) and the backlash of the gears is barely perceivable.

Loosen screws 6.

Rest the sewing hook against oil thrower 1.

Set the hook point opposite the center of the clearance cut of the needle.

Re-position bearing 5 so that between the hook point and the center of the clearance cut of the needle there is a clearance of 0.4 mm, making sure, however, that the bearing is not turned and the sewing hook is in contact with oil thrower 1.

Tighten screw 4 firmly.

Loosen screws 8.

Re-position gear 7 so that it is in alignment with the small gear.

Tighten screws 8, making sure that the second screw of gear 7, as seen in the direction of rotation, is in the groove of the shaft; in doing so, watch for the gear backlash.

Note:

Screws 6 remain loose for the following adjustment (section 21), and the oil tube remains swivelled out for the adjustment in section 25.

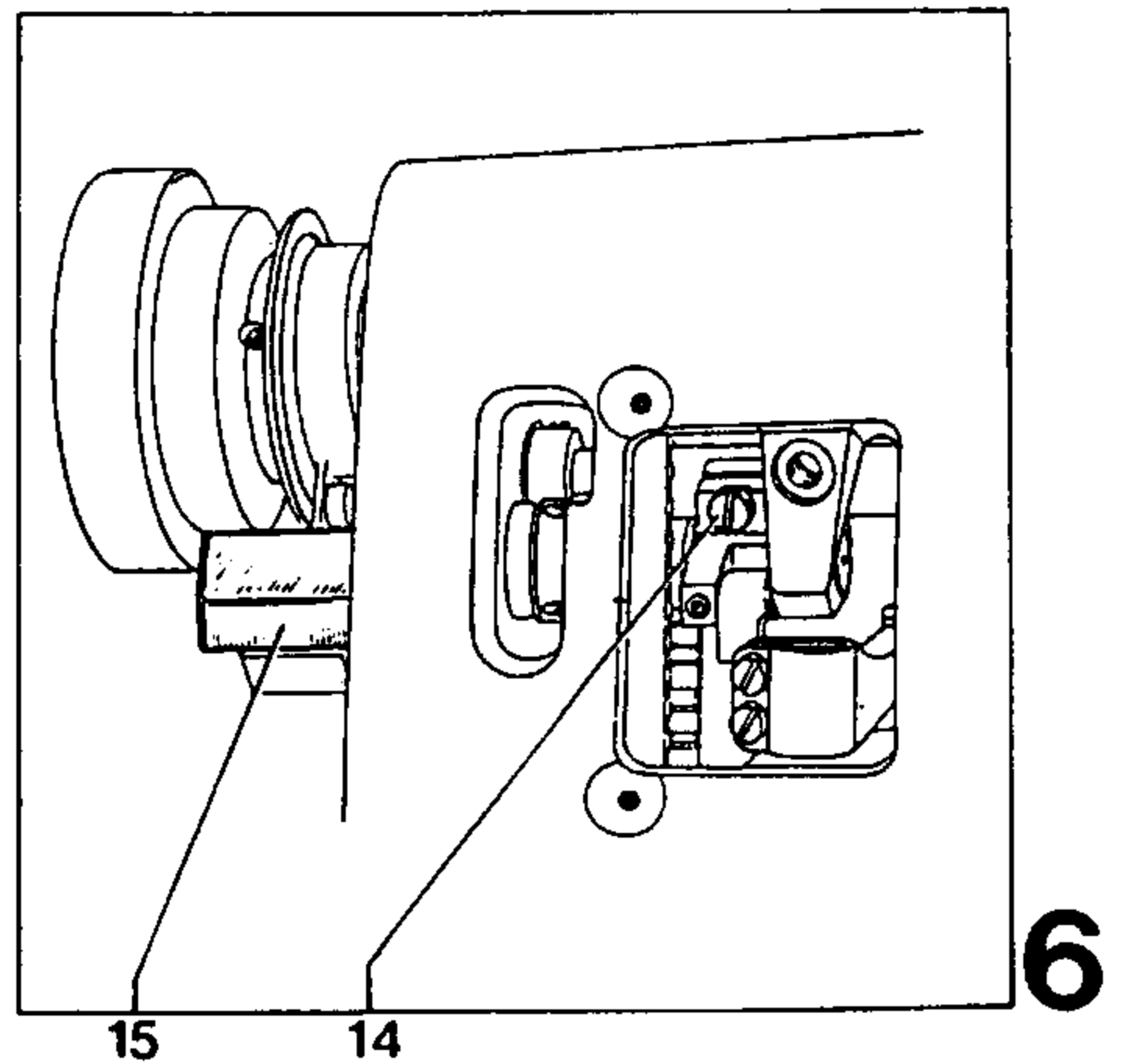
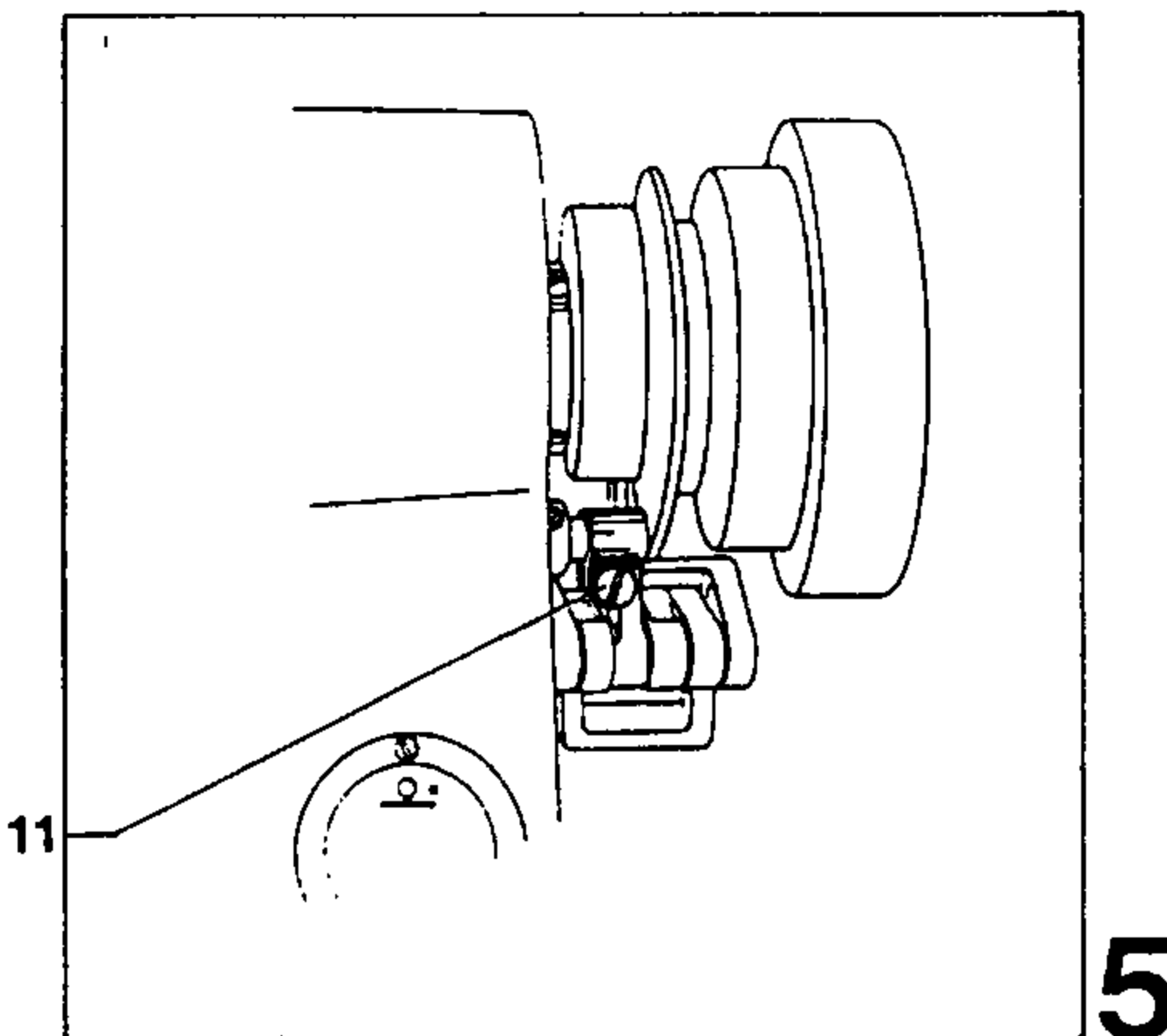
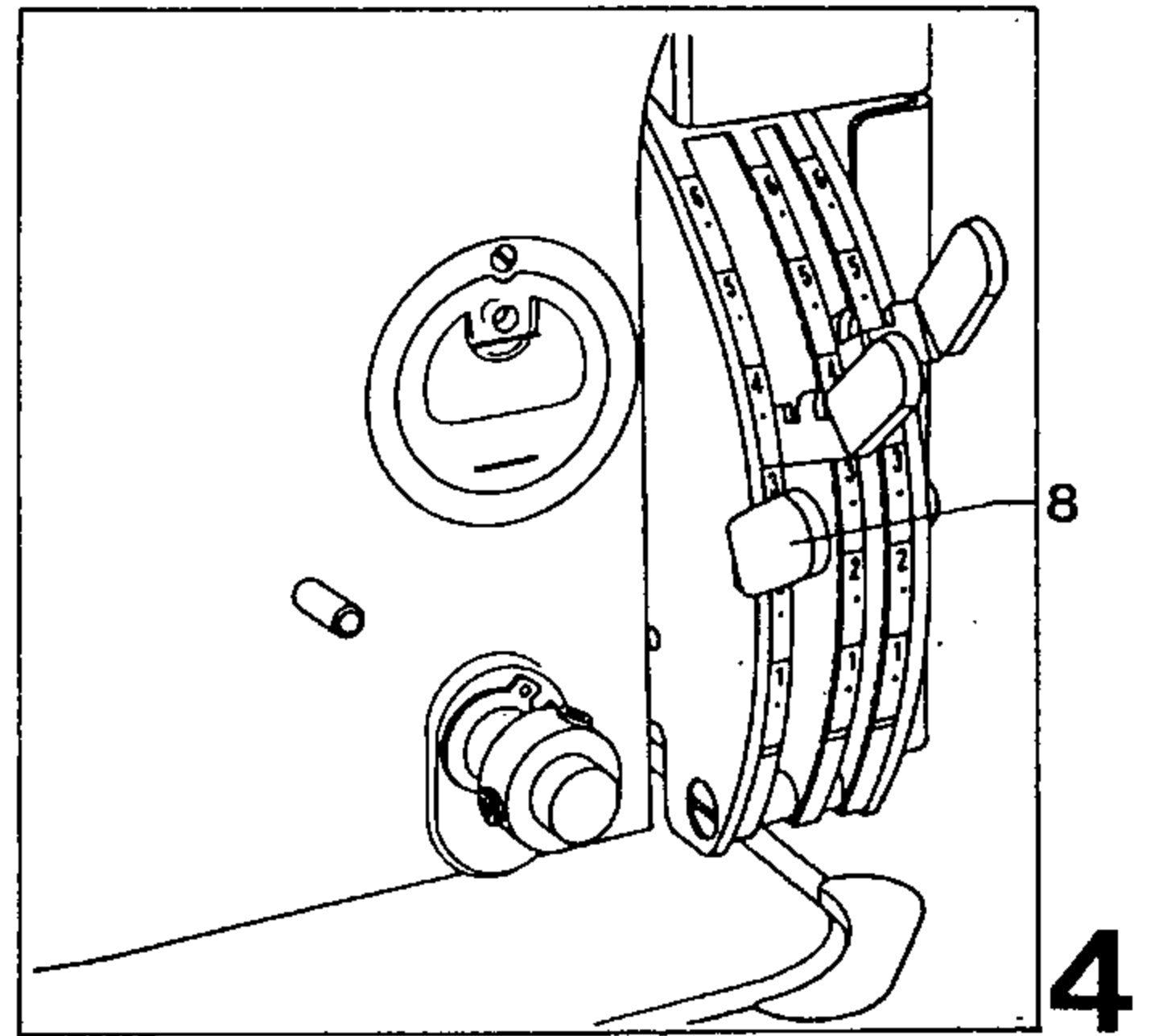
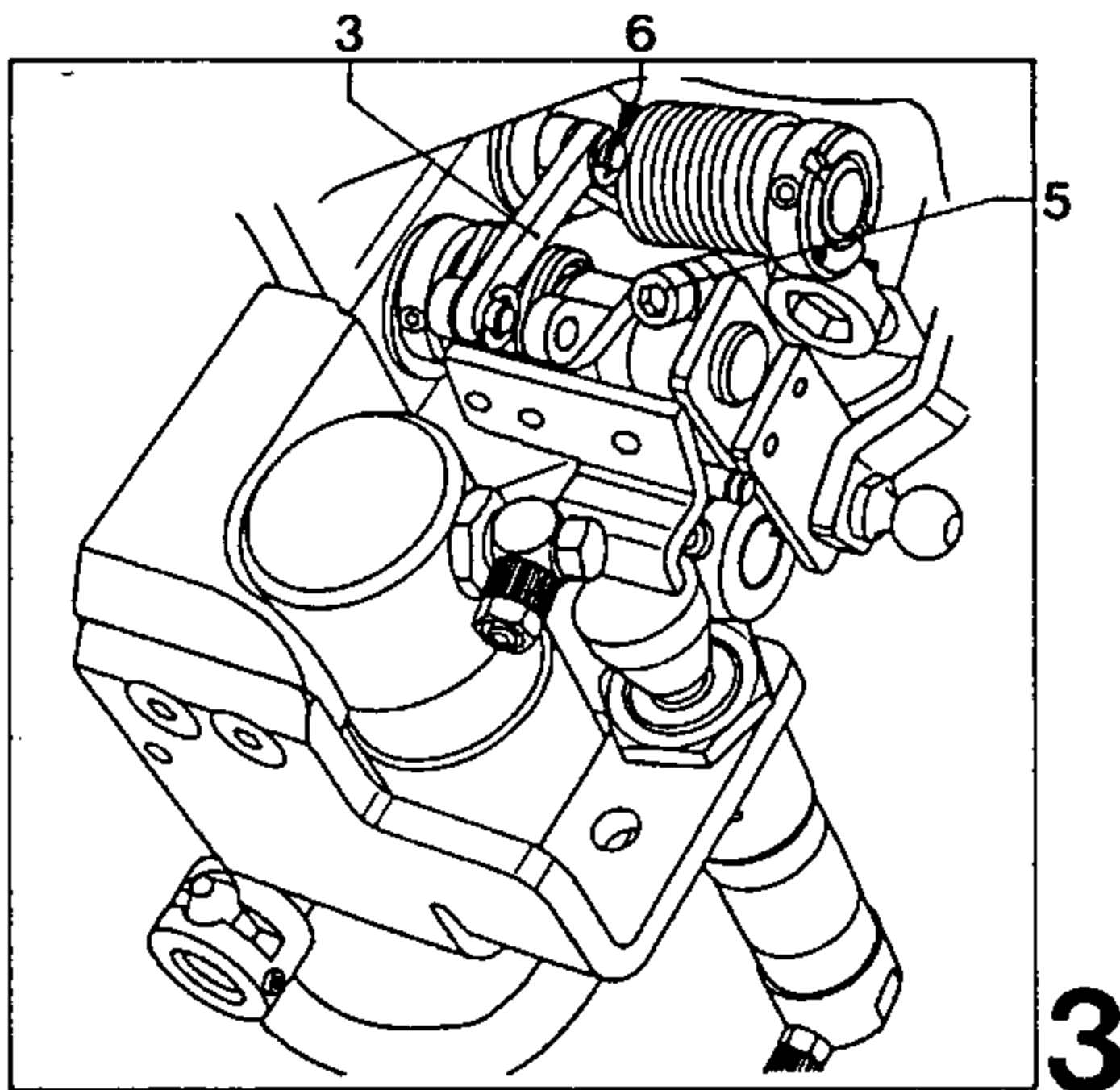
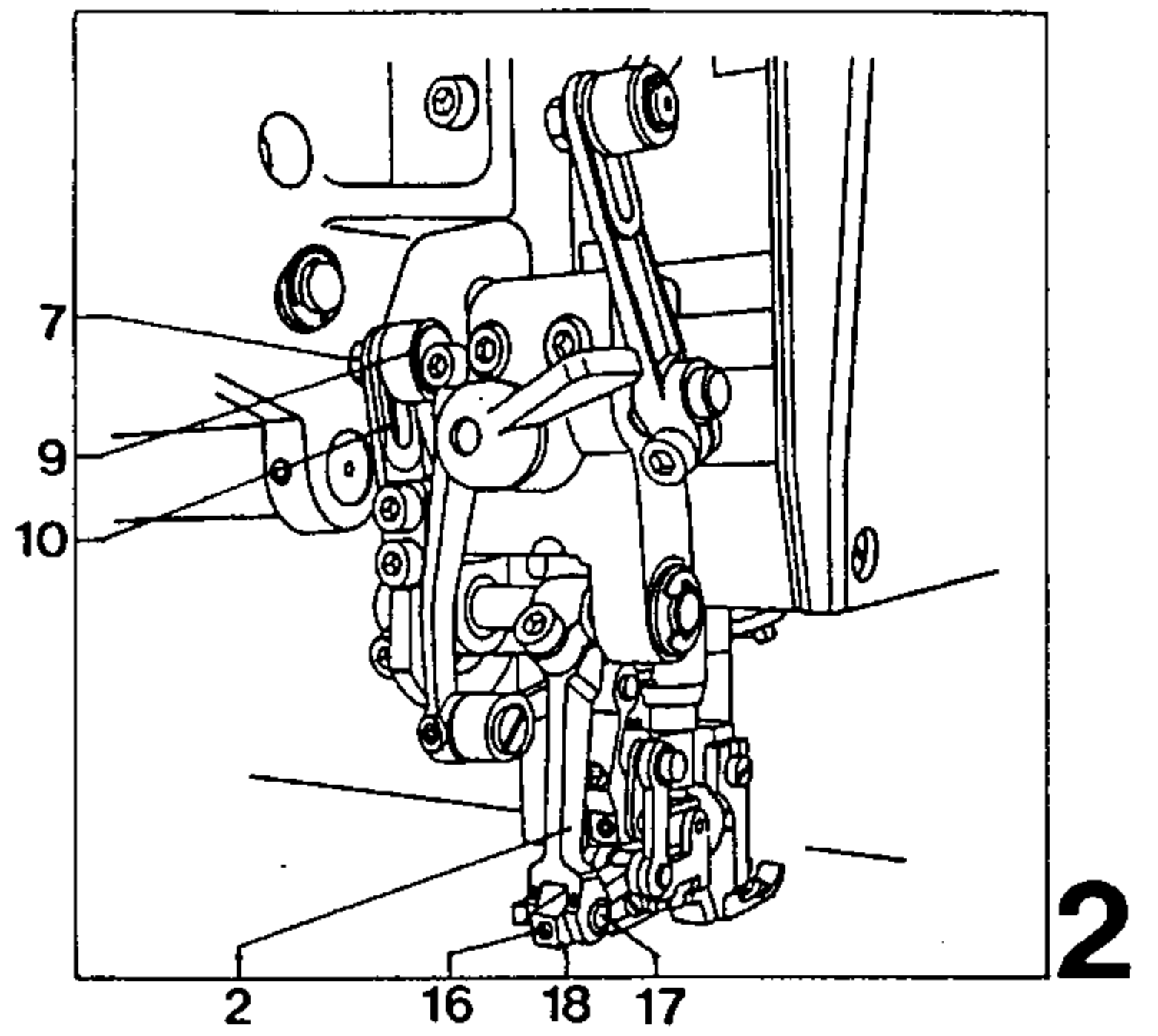
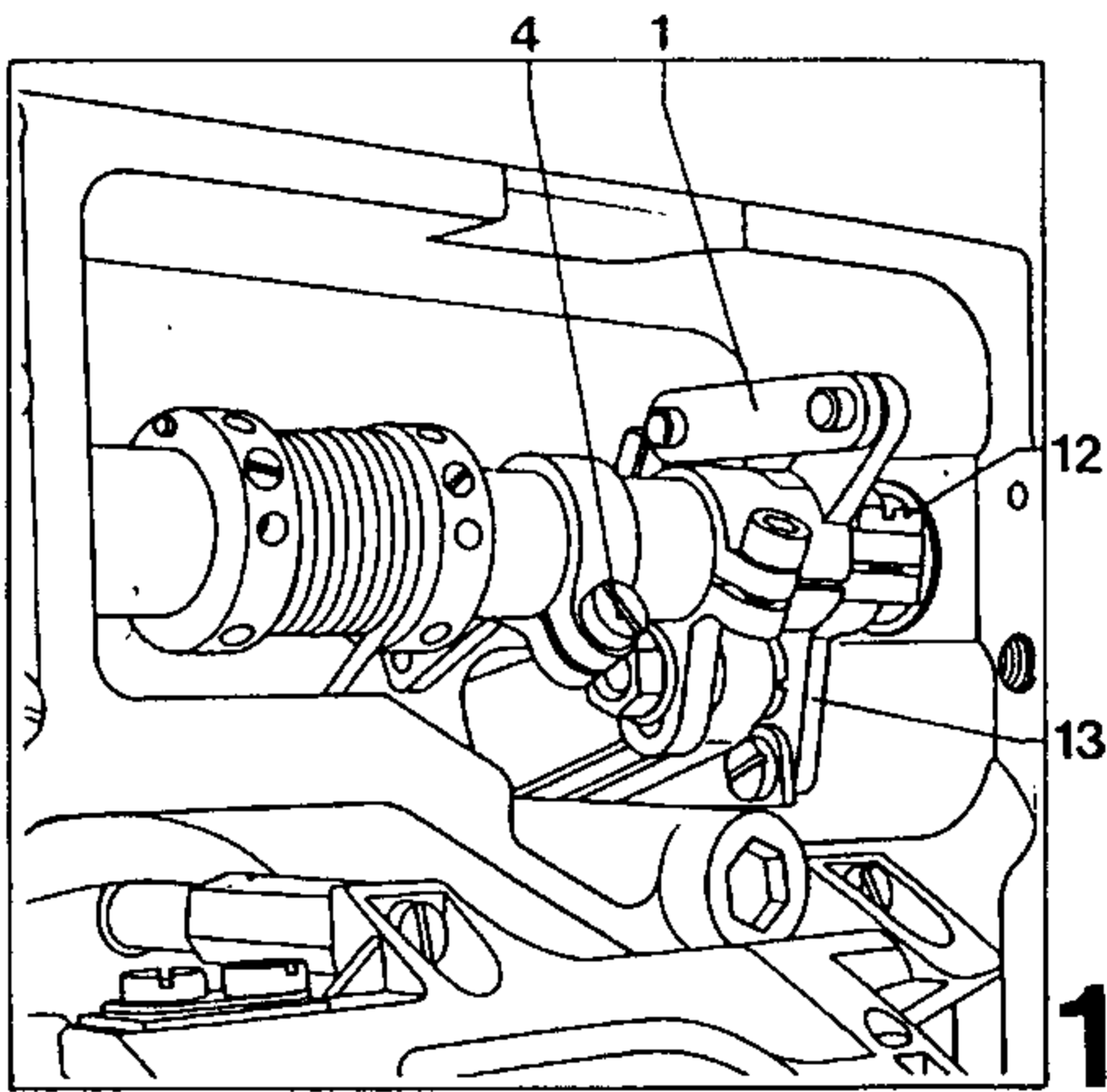

Push feed regulating shaft 19 (Fig. 7) up and hold it.

Turn actuating lever 20 (Fig. 8) so that there is a clearance of 3 to 4 mm between this lever and the base plate; in this position, tighten screw 6.

Replace link 3 and secure it with circlips 21.

Remove adjustment link 1.

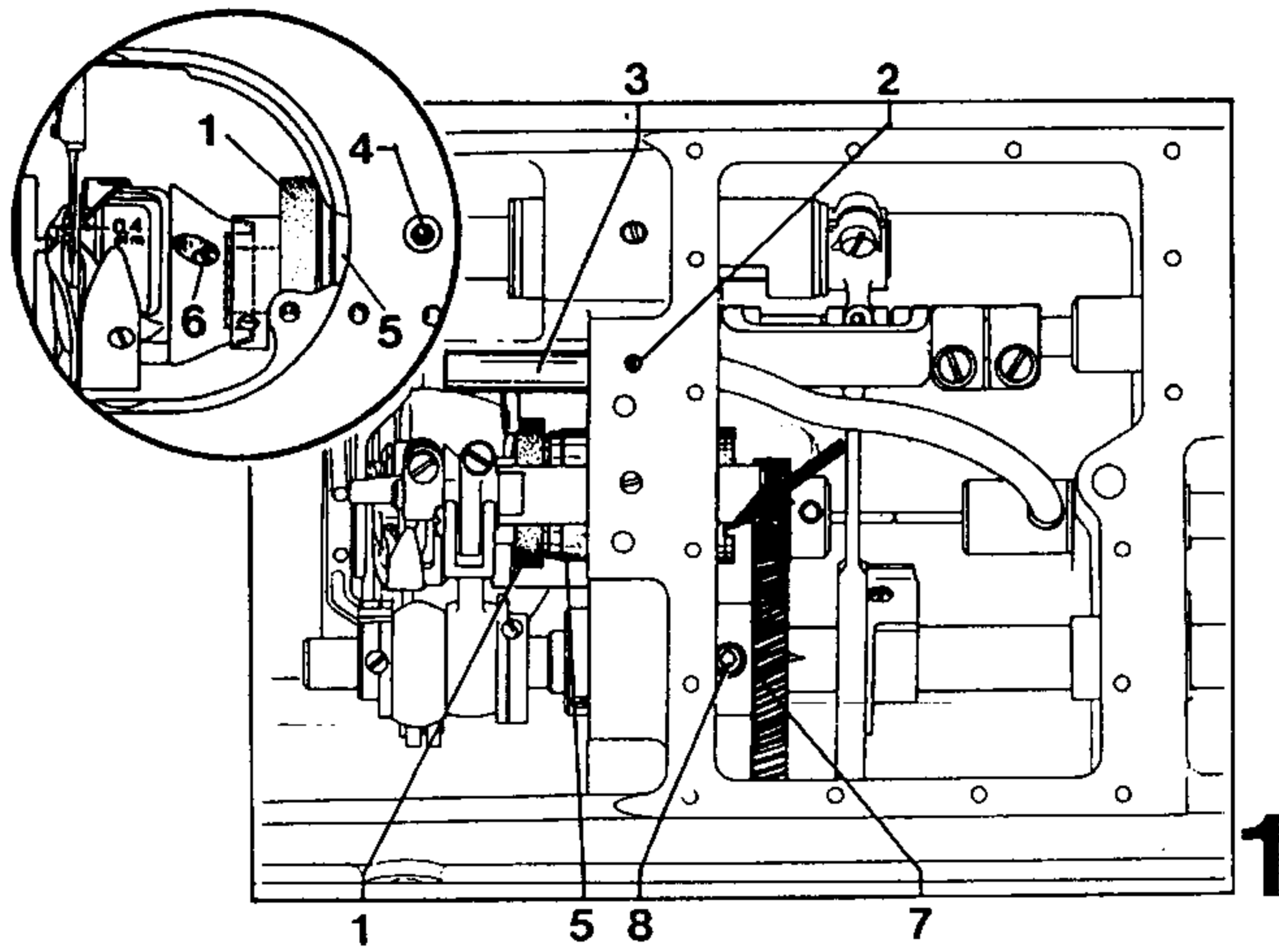

21 Needle height, needle rise and hook to needle clearance

With the needle bar 1.8 mm past b.d.c. (= adjustment hole "4"), the top edge of the needle eye must be 0.8 mm below the hook point (Fig. 1.1). Also in this position, there must be a clearance of 0.1 mm max. between the hook point and the needle (Fig. 1.2).

Loosen screws 2 (Fig.1.2) if not loose yet.

Set the needle bar 1.8 mm past b.d.c.; make sure the needle does not strike against the sewing hook.

Insert the adjustment pin in hole "4".

Loosen screws 1 (Fig. 1).

Set the hook point opposite the needle center.

Re-position the needle bar so that the top edge of the needle eye is 0.8 mm below the hook point; make sure the needle bar is not turned.

Tighten screws 1.

Make sure the position finger is in the groove of the bobbin case base and re-position the sewing hook so that there is a clearance of 0.1 mm max. between the hook point and the needle.

Tighten the accessible screw 2 (Fig. 1.2).

Take out the adjustment pin and tighten the second screw 2.

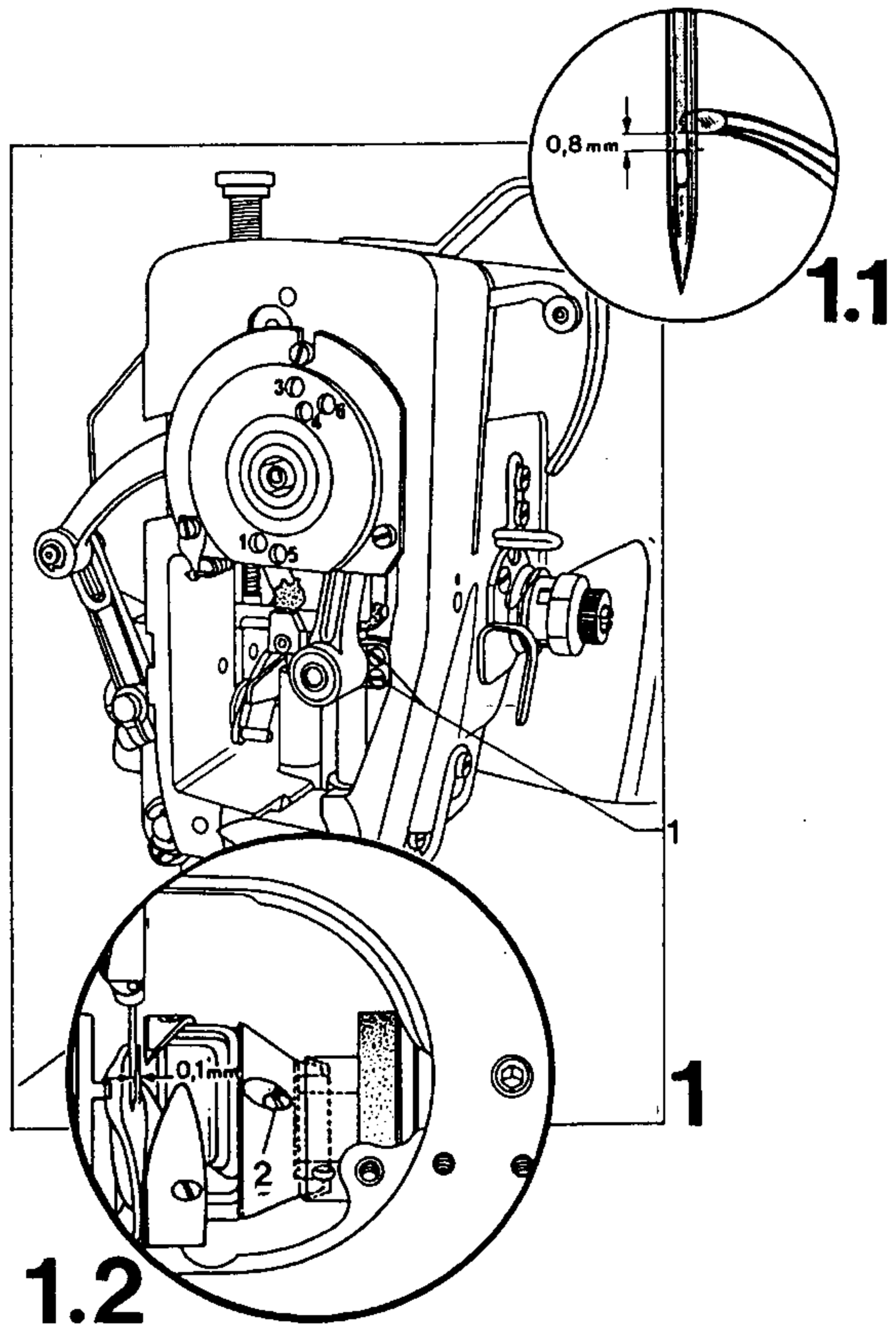

22 Eccentric bearing of bobbin case opener shaft

At the left point of reversal of bobbin case opener 1, the height of the bobbin case opener finger must be adjusted so that the finger is exactly aligned with the lug of bobbin case base 2 (Fig. 1.1).
It must be easy to take the bobbin case out of the sewing hook.

Loosen screw 3 (Fig. 1).

Turn the balance wheel to set the bobbin case opener at its left point of reversal.

Turn eccentric bearing 4 of the bobbin case opener shaft so that the bobbin case opener finger is exactly aligned with the lug of bobbin case base 2.

Tighten screw 3.

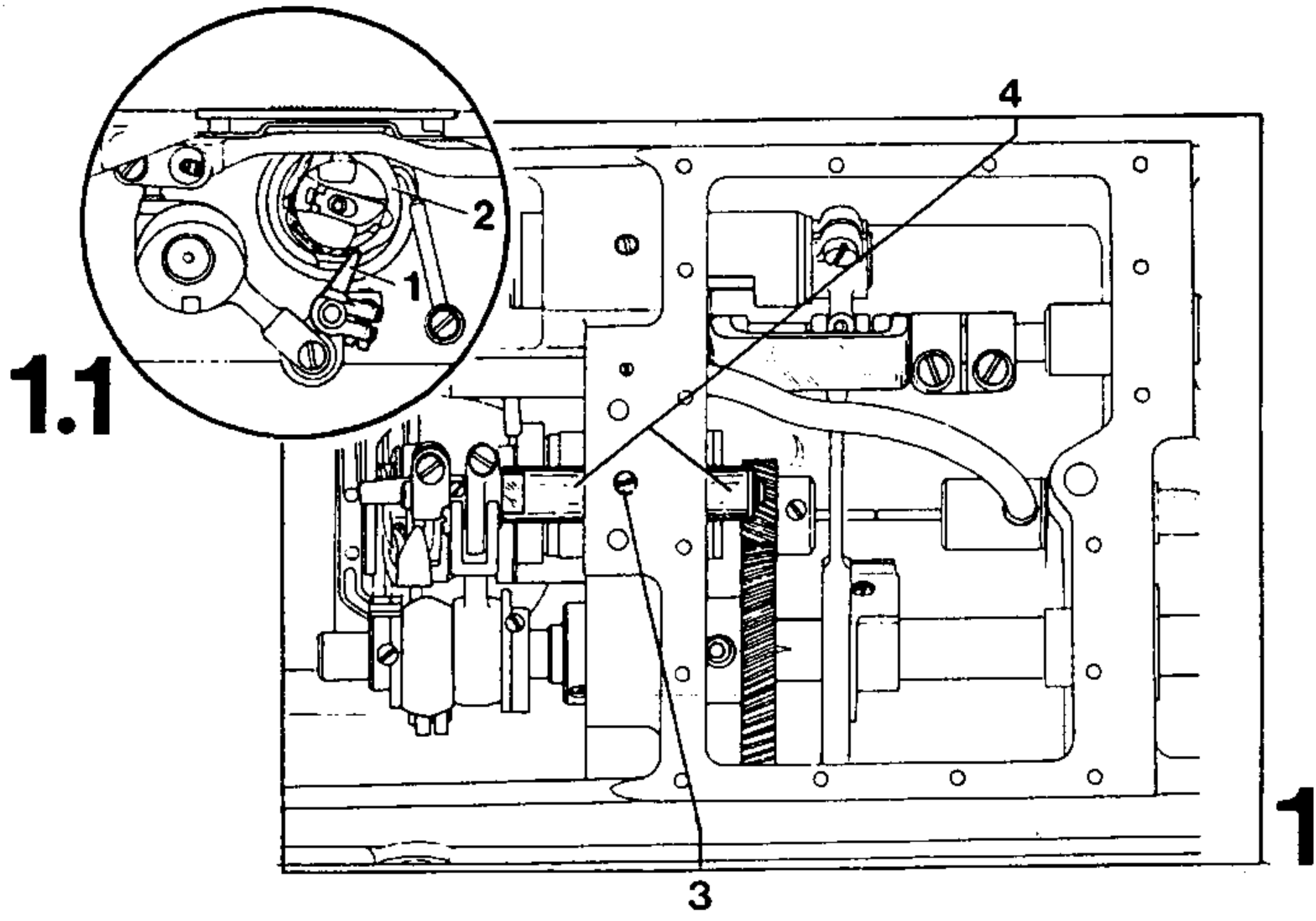

23 Bobbin case opener position

The clearance between the finger of bobbin case opener 1 and the rim of bobbin case base 2 must be about 0.8 mm (Fig. 1.1). Also, at the left point of reversal of bobbin case opener 1, bobbin case base 2 must be pushed away from position finger 3 by about 0.3 mm (Fig. 1.2). Stop screw 4 must then contact stop pin 5 of bobbin case opener 1 (Fig. 1.3).

Loosen screw 4, and screw 6 just enough to allow bobbin case opener 1 to be moved.

Re-position bobbin case opener 1 on its shaft until there is a clearance of 0.8 mm between the finger of the bobbin case opener and the rim of the bobbin case base (Fig. 1.1).

Turn balance wheel to set bobbin case opener 1 at its left point of reversal.

Turn bobbin case opener 1 on its shaft until bobbin case base 2 is pushed away from position finger 5 by about 0.3 mm (Fig. 1.2).

Tighten screw 6 firmly.

Rest fixing collar 7 against bobbin case opener 1 and turn it so that stop screw 4 contacts stop pin 5 of bobbin case opener 1 (Fig. 1.3).

Tighten screw 4.

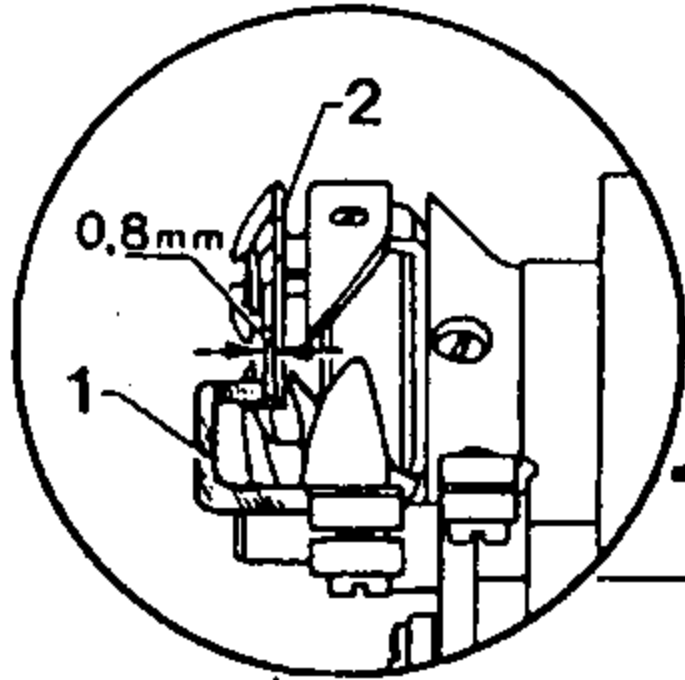

1.1

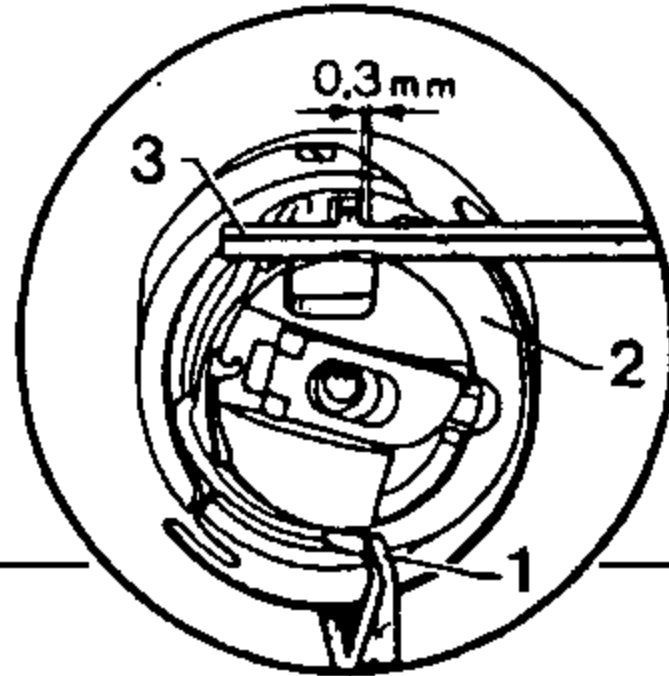

1.2

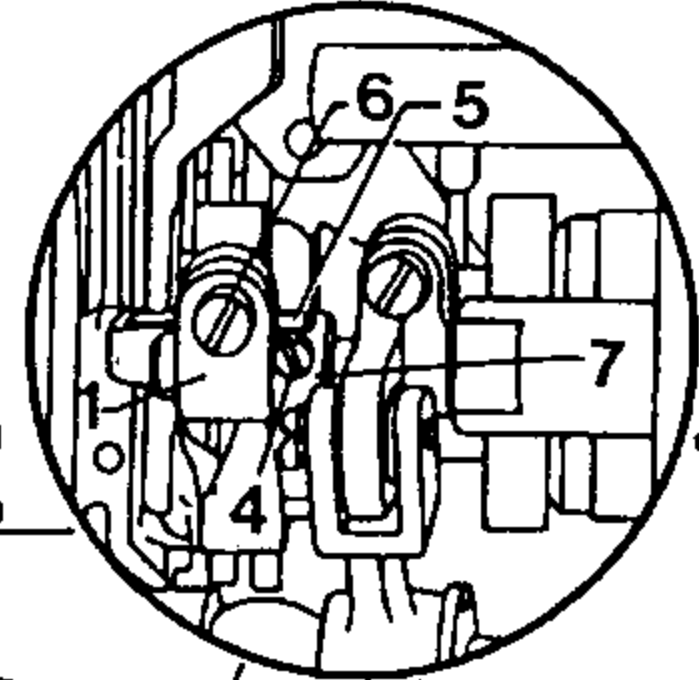

1.3

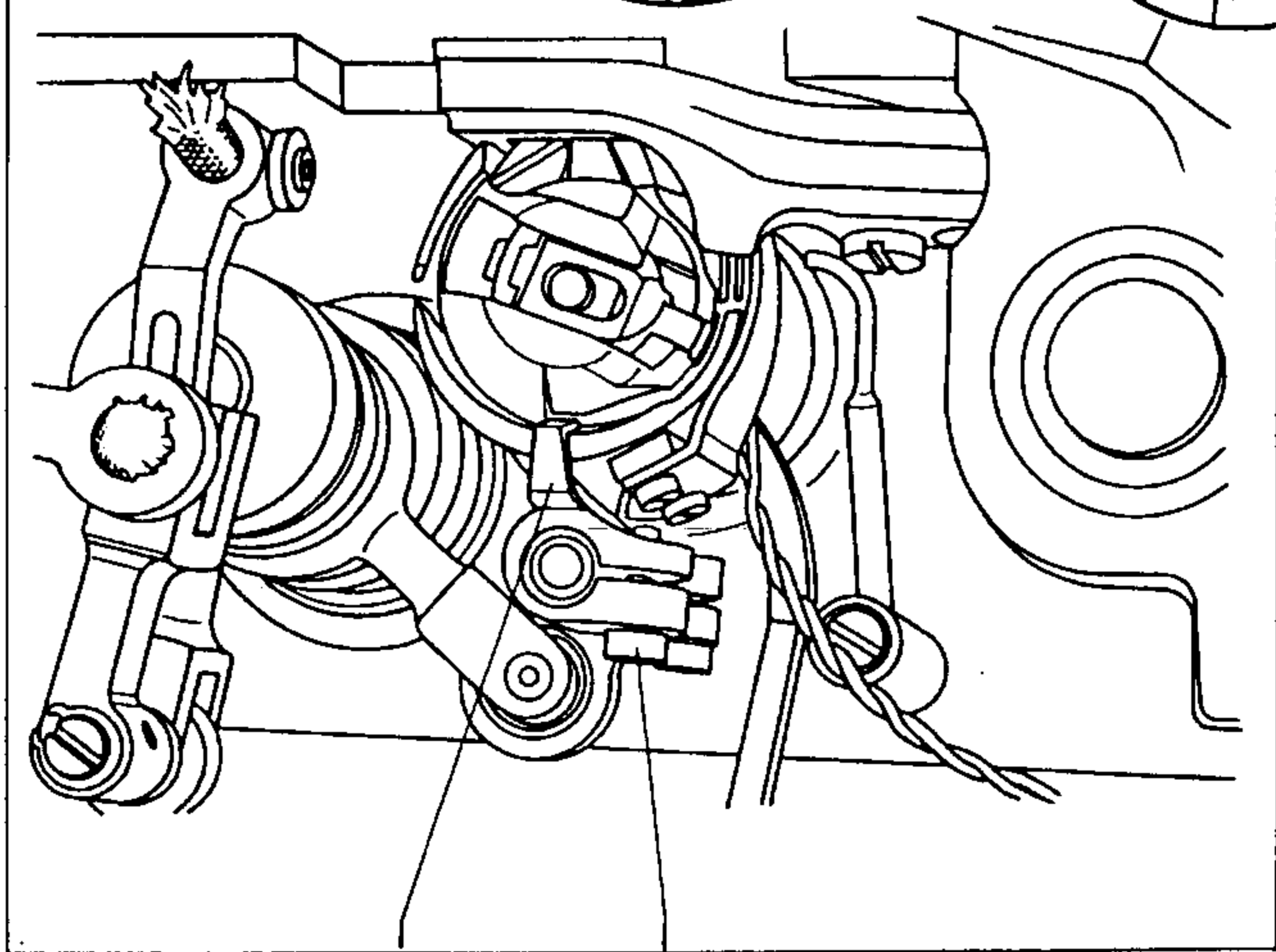

1

6

1

24 Bobbin case opener movement

When the needle bar is 1.8 mm past b.d.c. (= adjustment hole "4"), bobbin case opener 1 must be at its right point of reversal (Fig. 1.1).

Loosen screws 2 (Fig. 1).

Set the needle bar 1.8 mm past b.d.c.

Insert the adjustment pin in hole "4".

For exact determination of the reversal point, insert a small screw driver in the clamp slot of bobbin case opener 1.

Turn eccentric 3 so that bobbin case opener 1 is at its right point of reversal.

Tighten the accessible screw 2, watching for the play between eccentric 3 and the lifting eccentric.

Remove the adjustment pin and the screwdriver and tighten the second screw 2.

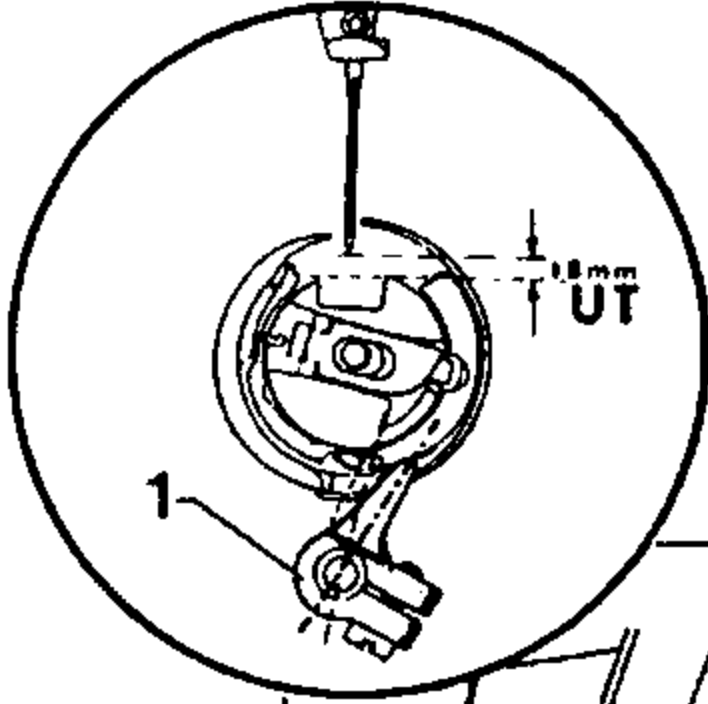
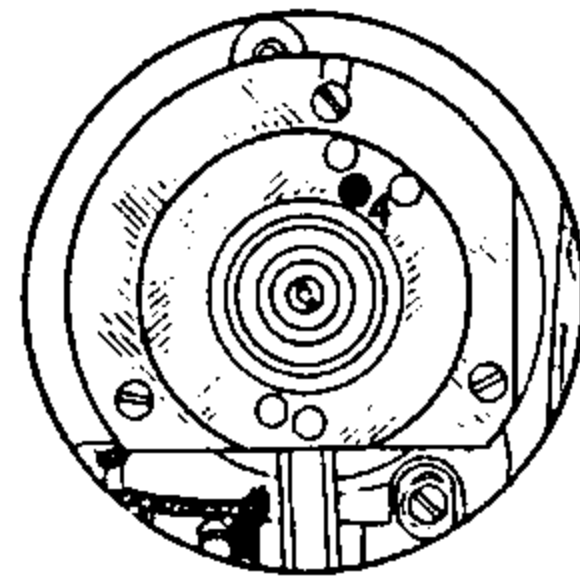

1.1

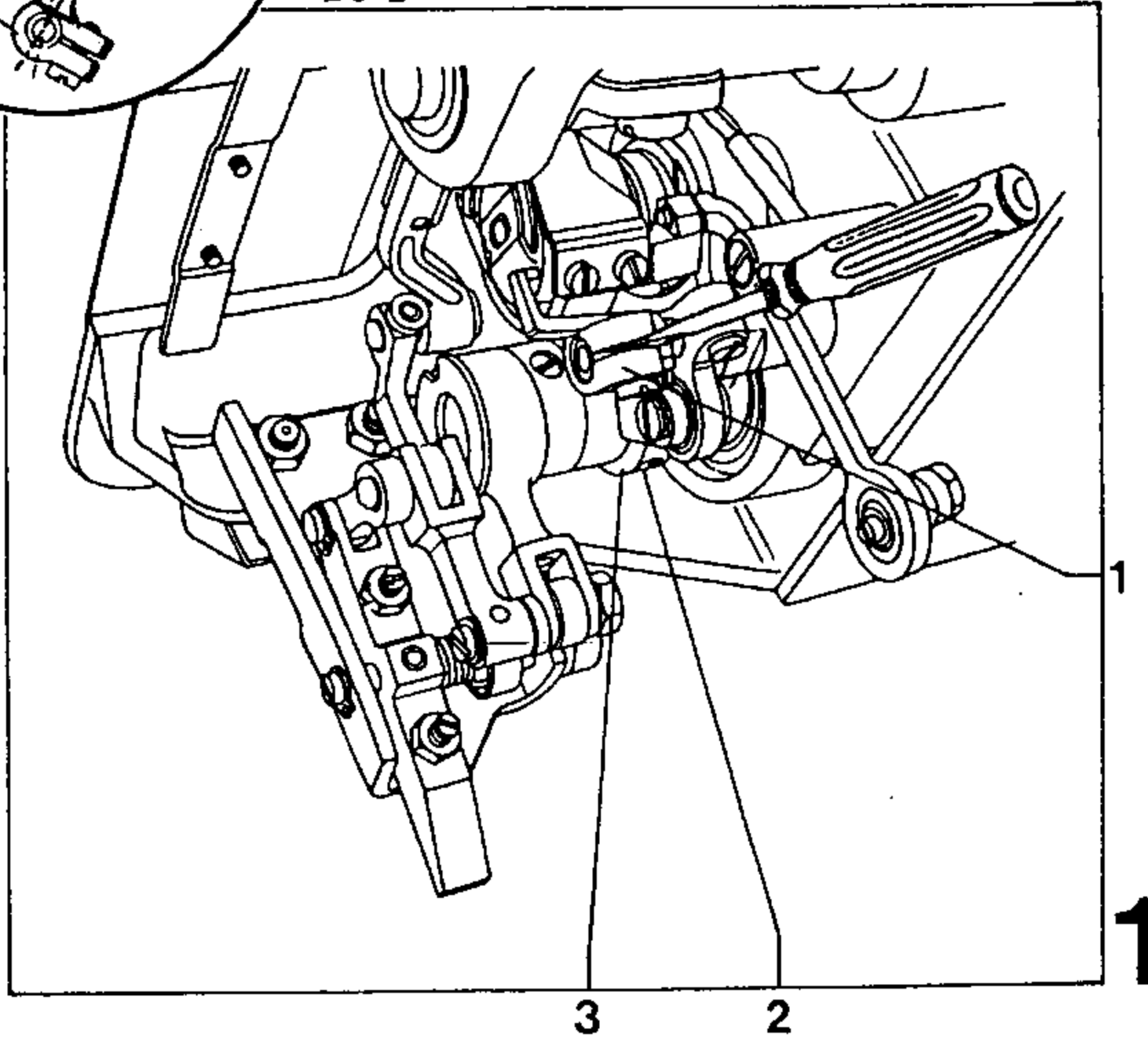

25 Oil tube in oil thrower

Oil tube 1 must be in the hole of oil thrower 2 (Fig. 1).

Loosen the screws of oil thrower 2.

Turn oil thrower 2 so that oil tube 1 can be inserted in the hole.

Insert oil tube 1 in the hole by turning it.

Tighten screw 3.

Tighten the screws of oil thrower 2.

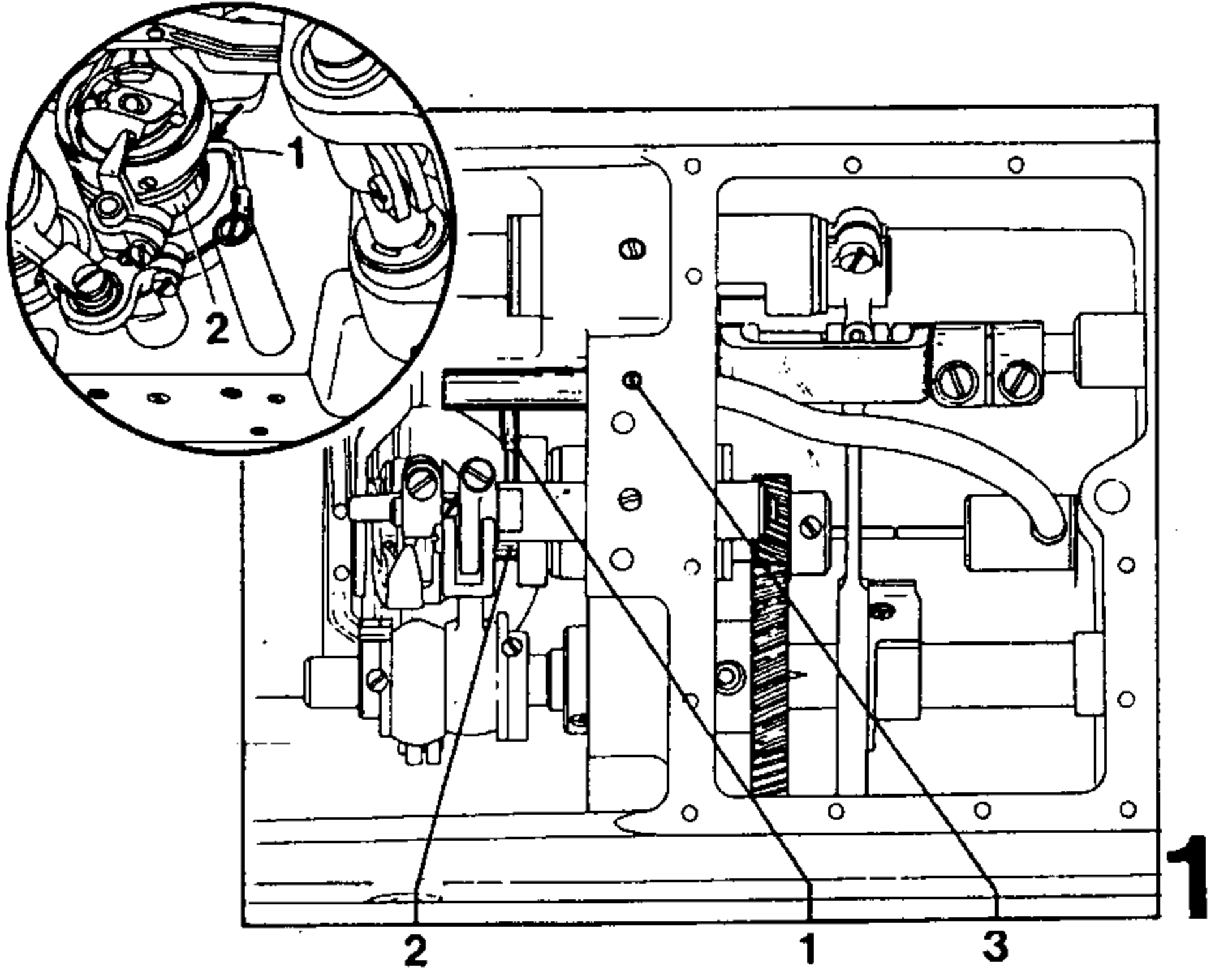

Between actuating plunger 1 of the centrifugal governor and valve rod 2 of the oil check valve there must be 1 mm of play (see Fig. 1.1).

Loosen screw 3 (Fig. 1).

Push actuating plunger 1 into the centrifugal governor as far as it will go.
Push valve rod 2 into check valve 4 until a resistance is felt.

Re-position check valve 4 so that there is a distance of 1 mm between actuating plunger 1 and valve rod 2.

Tighten screw 3.

Push the soaked lubricating pad (with the big cutout facing left down) between the oil tube and the gearing.

Clean the gasket and gasket surface of the gearcase.

Screw on the gearcase cover and both sewing head supports.

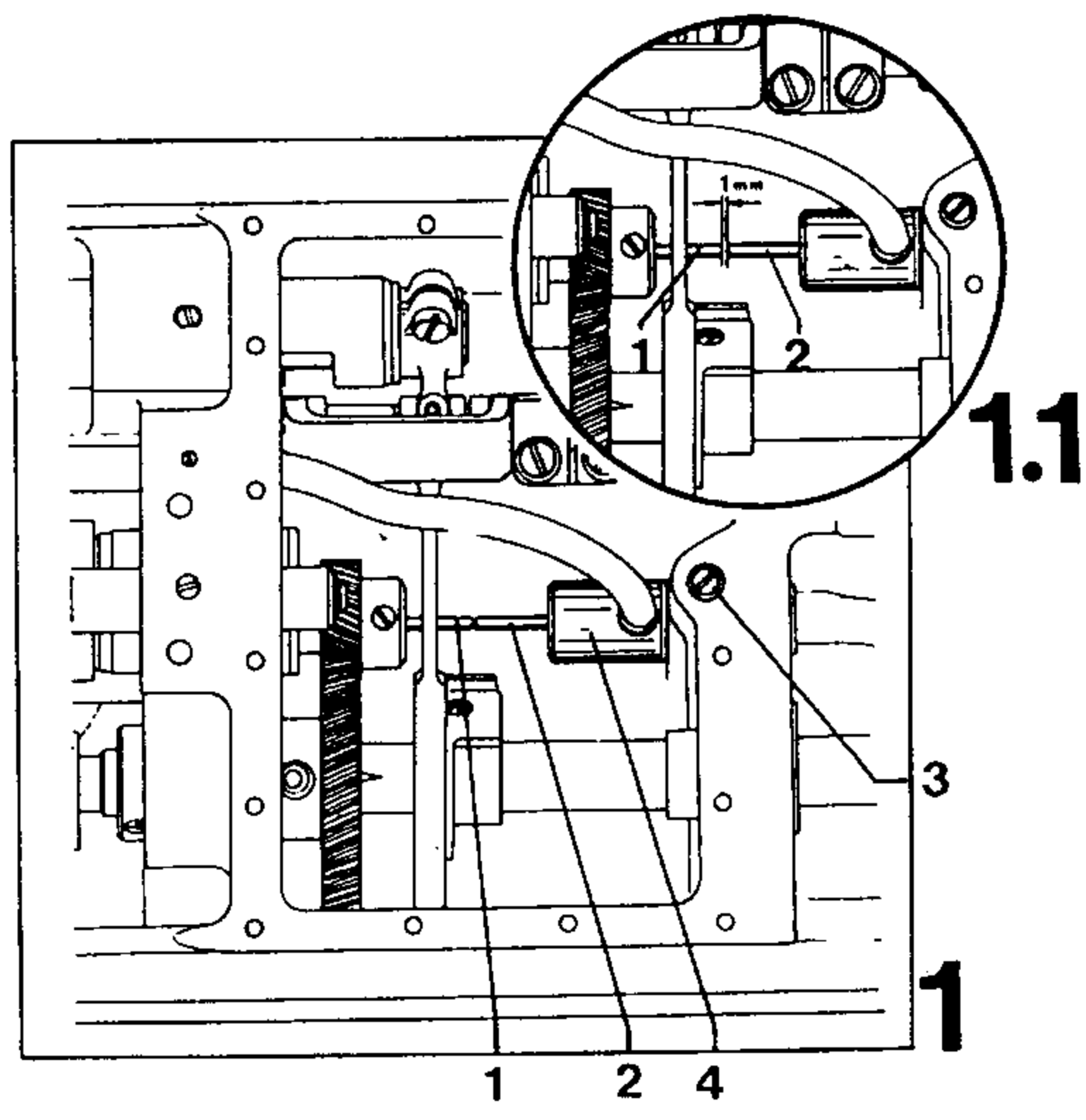

27 Needle thread tension release

When the lifting lever is raised, the two tension discs must be at least 0.5 mm apart.

Raise the presser foot by means of the lifting lever.

Loosen screw 1.

Adjust tension release lever 2 so that the two tension discs are pushed apart by at least 0.5 mm.

Tighten screw 1.

When the presser foot touches the needle plate, the tension must be fully activated.

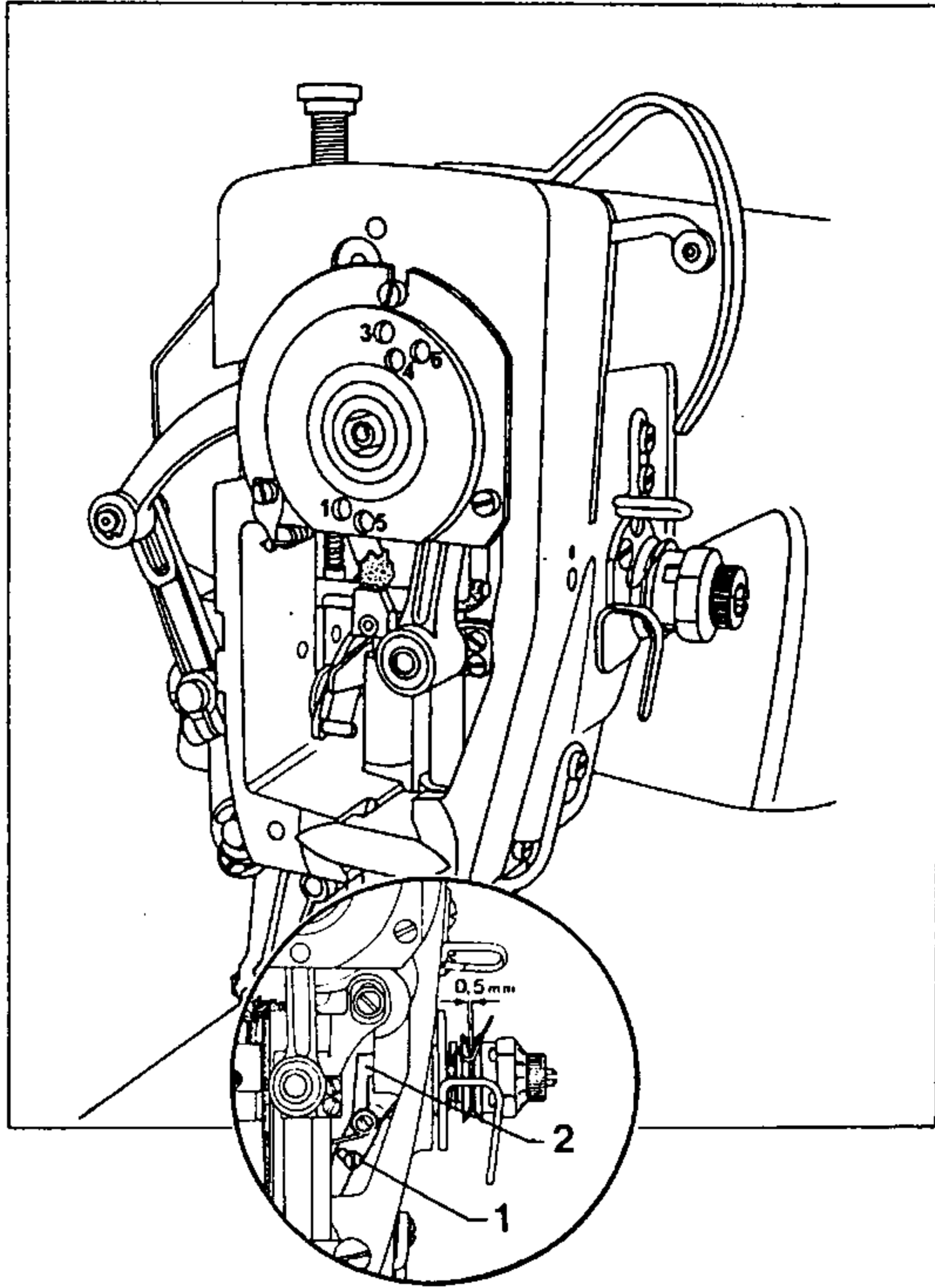

28 Thread check spring and thread regulator

The stroke of the thread check spring must be about 5 to 7 mm (Fig. 1.1).

Note:

Both the stroke of the thread check spring and the position of the thread regulator depend on the material and thread used, and have to be adjusted according to the appearance of the seam.

Loosen screws 1 (Fig. 1) just enough to allow the thread tension to be turned.

Turn the thread tension so that the stroke of the thread check spring is about 5 to 7 mm.

Tighten screws 1 evenly.

Loosen screws 2.

Push the thread regulator up as far as it will go and tighten screws 2.

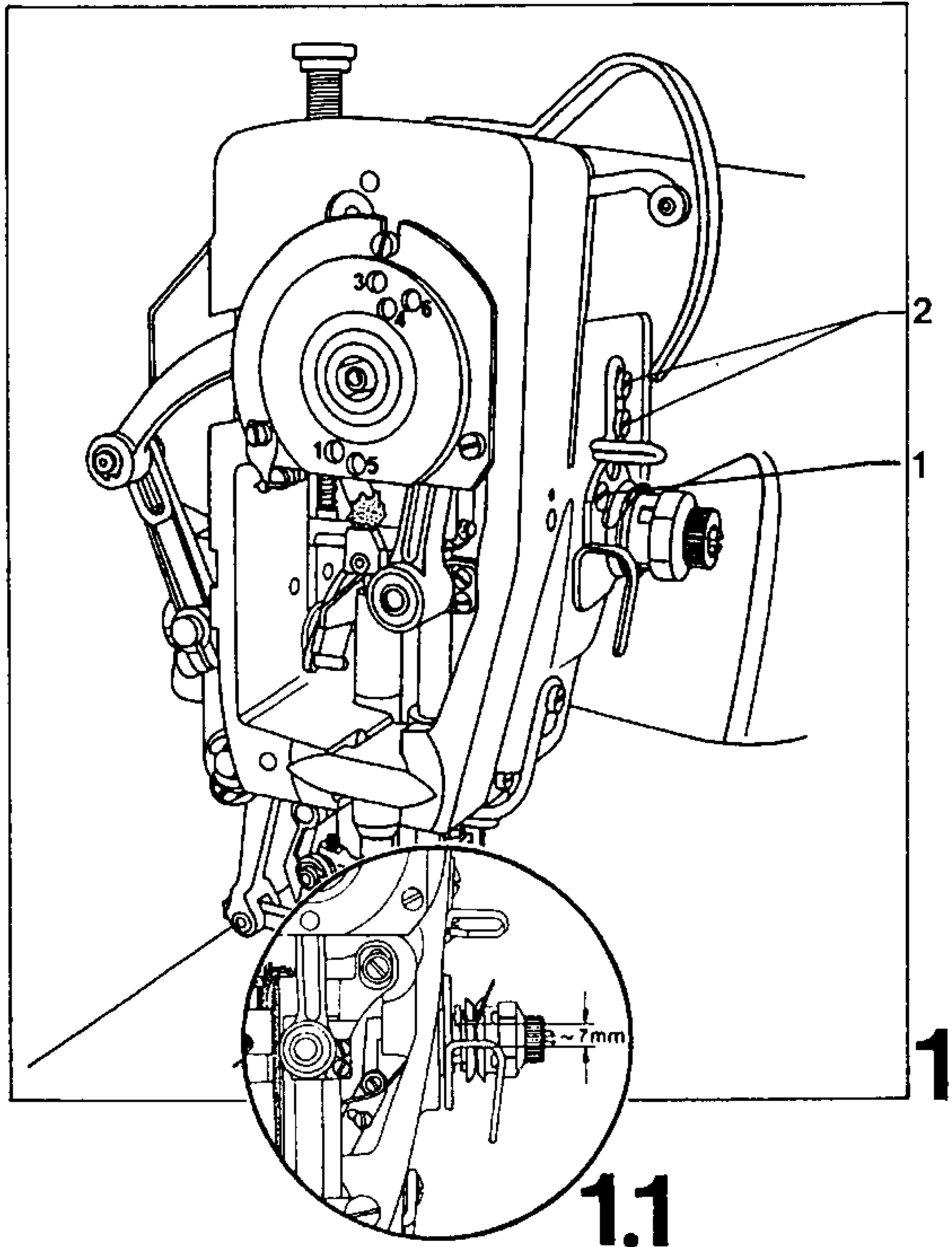

When the bobbin winder is engaged, the winder spindle must be driven reliably; when the winder is disengaged, friction wheel 1 (Fig. 1) must not contact winder drive wheel 2. Also, the bobbin winder must be automatically disengaged when the thread wound on the bobbin has reached a point about 1 mm below the rim (Fig. 1.1).

Raise the presser foot by means of the lifting lever and engage the bobbin winder.

Loosen screws 3 (Fig. 1).

Re-position winder drive wheel 2 sideways so that the winder spindle is reliably driven when the bobbin winder is engaged, and that there is no contact between winder drive wheel 2 and friction wheel 1 when the bobbin winder is disengaged.

Tighten screws 3.

Place an empty bobbin on the winder spindle, thread the machine for bobbin winding, engage the bobbin winder, and switch on the machine.

If the bobbin winder is disengaged too soon or not at all, loosen screw 4.

If the bobbin is too full, push adjusting pin 5 in, or push it out if the bobbin is not full enough, and tighten screw 4.

If the thread piles on one side, adjust the thread guide on the machine arm accordingly.

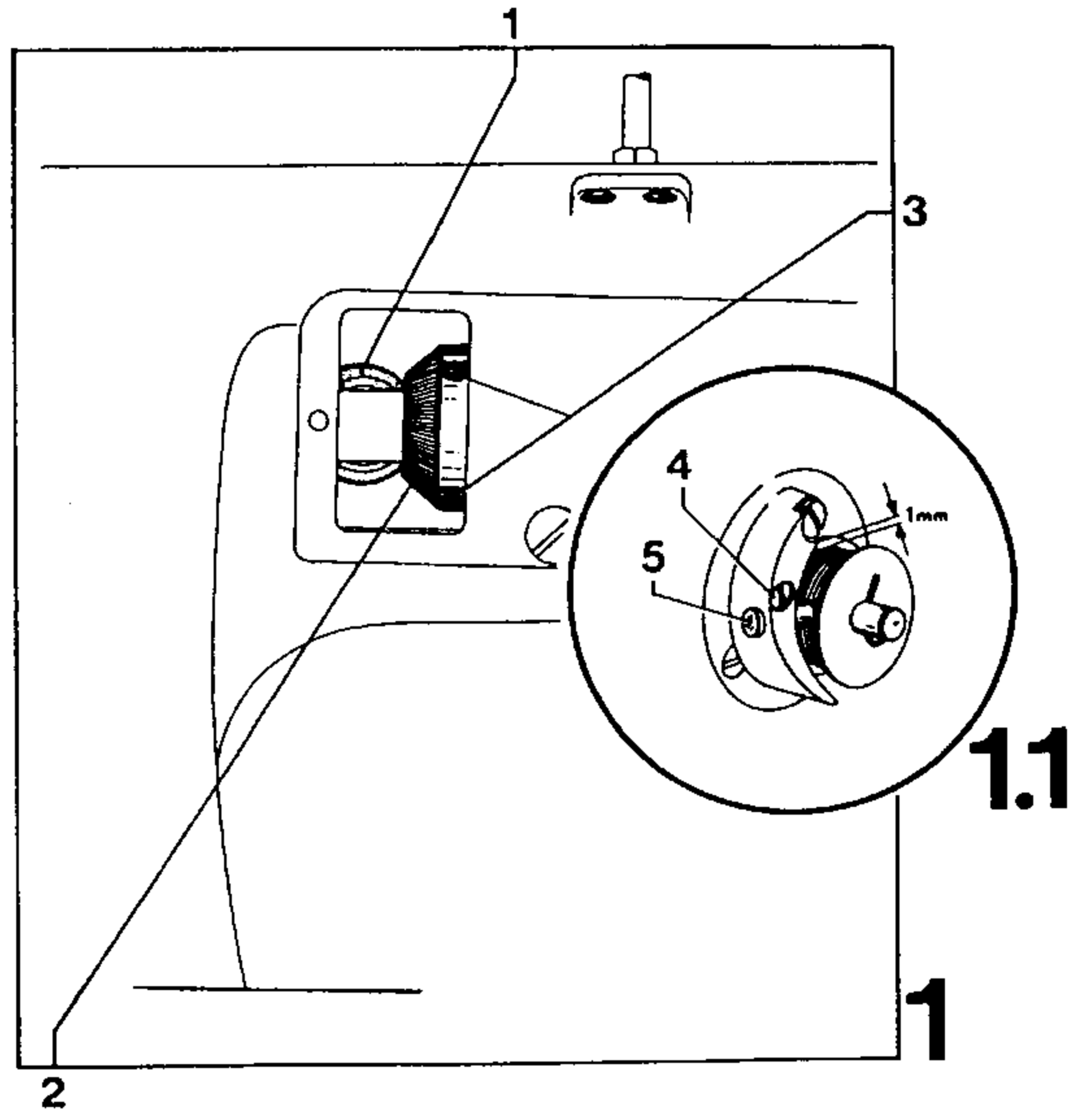

30 Pressure of vibrating presser and presser foot

The pressure of vibrating presser and presser foot on the material sewn must be adjusted so that proper feeding is ensured even at top speed.

30.1 Basic adjustment

Set the head of regulating screw 1 (Fig. 1.1) flush with the beginning of the screw thread.

Turn in knurled sleeve 2 (Fig. 1.2) until there is a distance of about 12 mm between its collar and the machine housing.

30.2 Pressure of vibrating presser

Turning regulating screw 1 in increases the pressure on the vibrating presser; turning the screw out decreases the pressure.

30.3 Pressure of presser foot

Turning knurled sleeve 2 in increases the pressure; turning it out decreases the pressure.

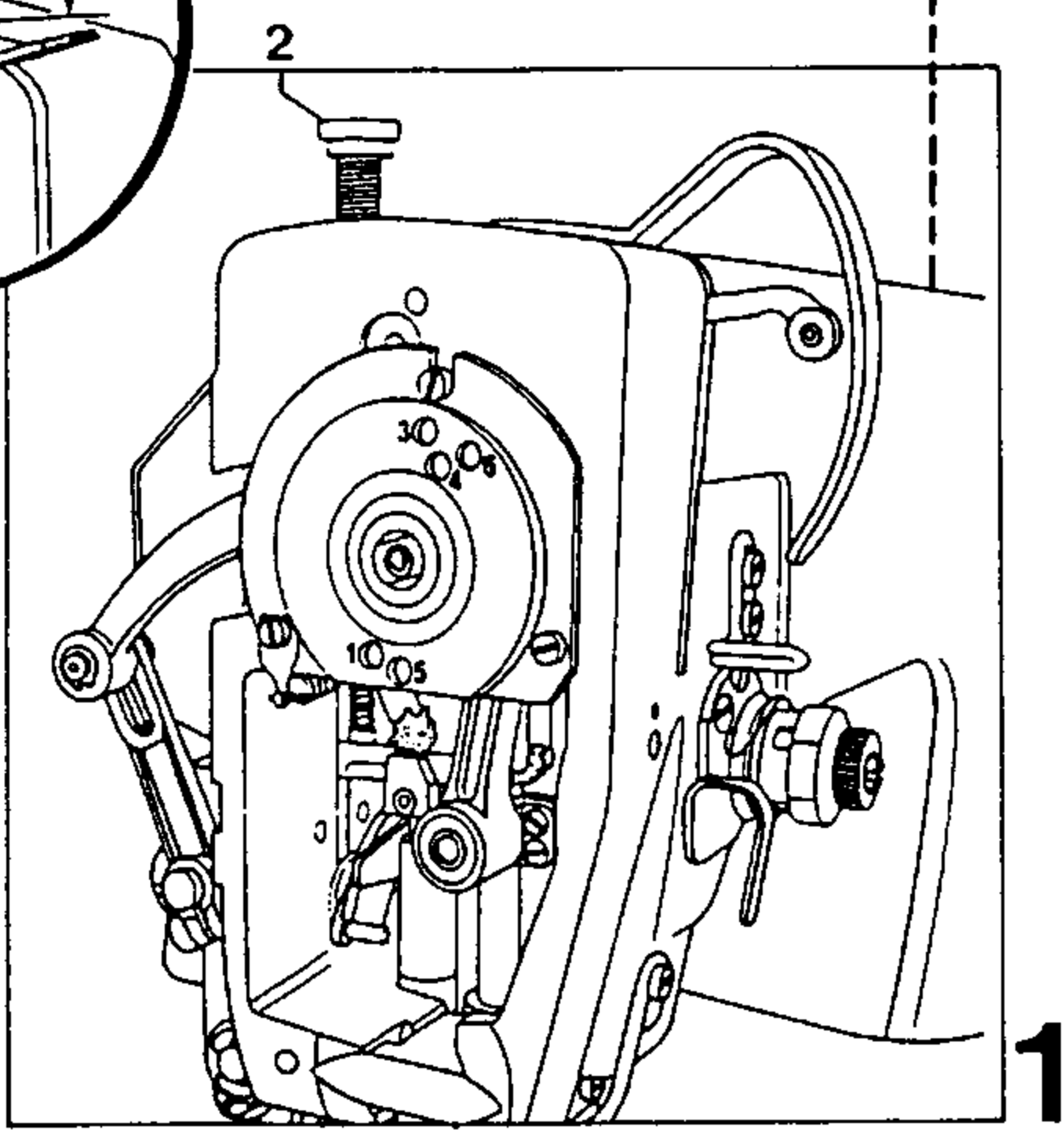
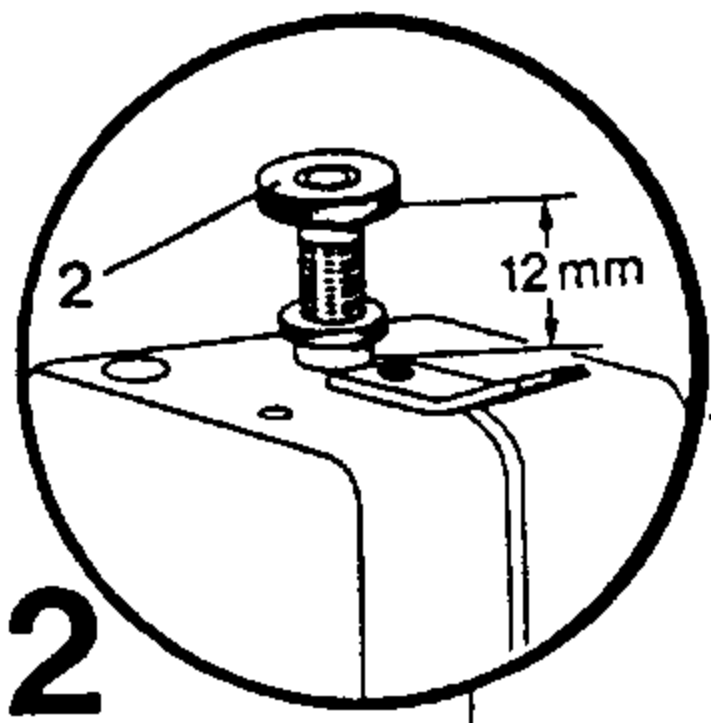
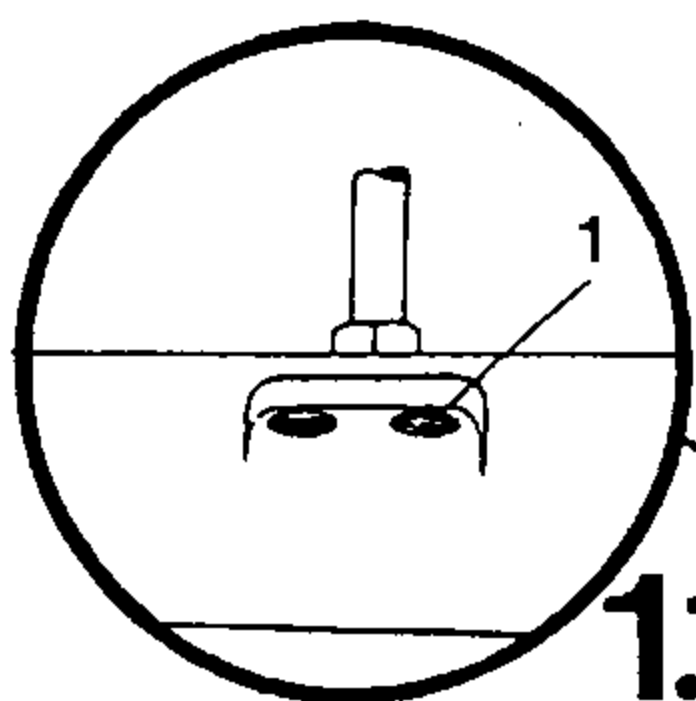

31 Stitch length limitation

Depending on the limitation value, loosen screw 1 (Fig. 1.1) or remove it altogether.

Set stitch length 4.5 mm at regulating lever 2 (Fig. 1).

Rest stop 3 (Fig. 1.1) against regulating lever 2 from above and fix it with screw 1 in the upper or lower hole.

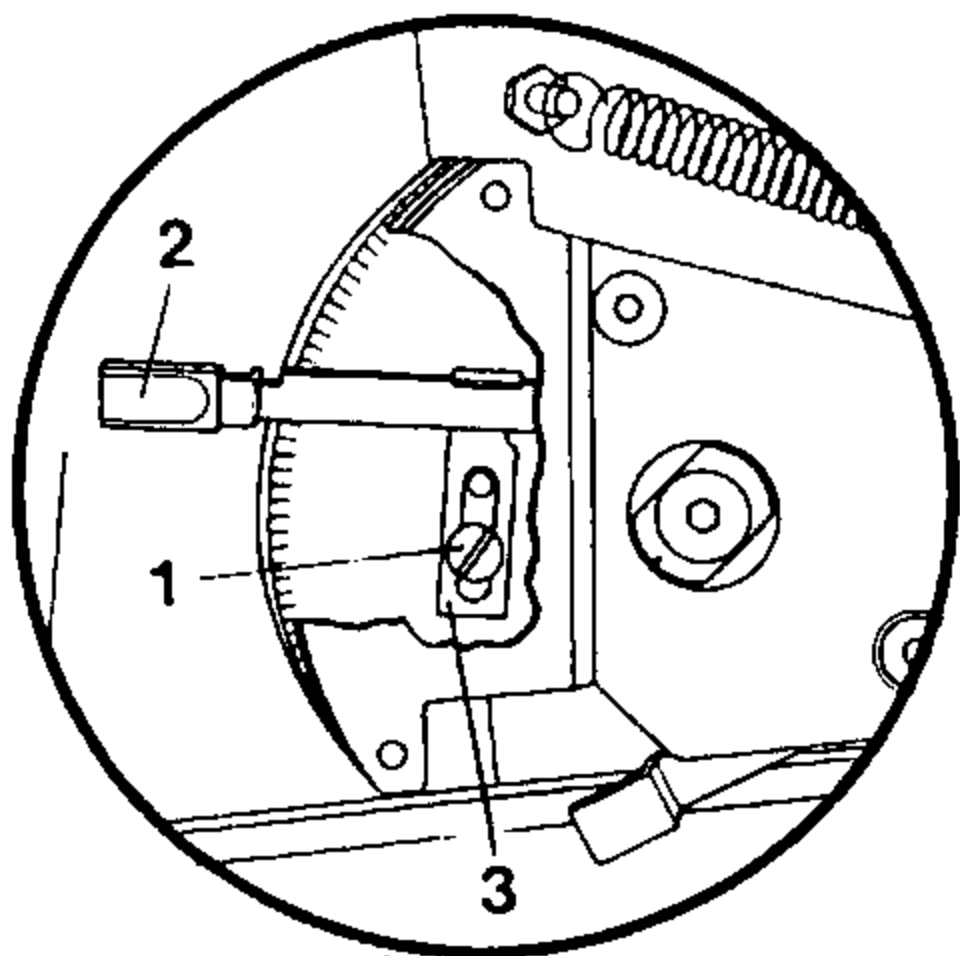

1.1

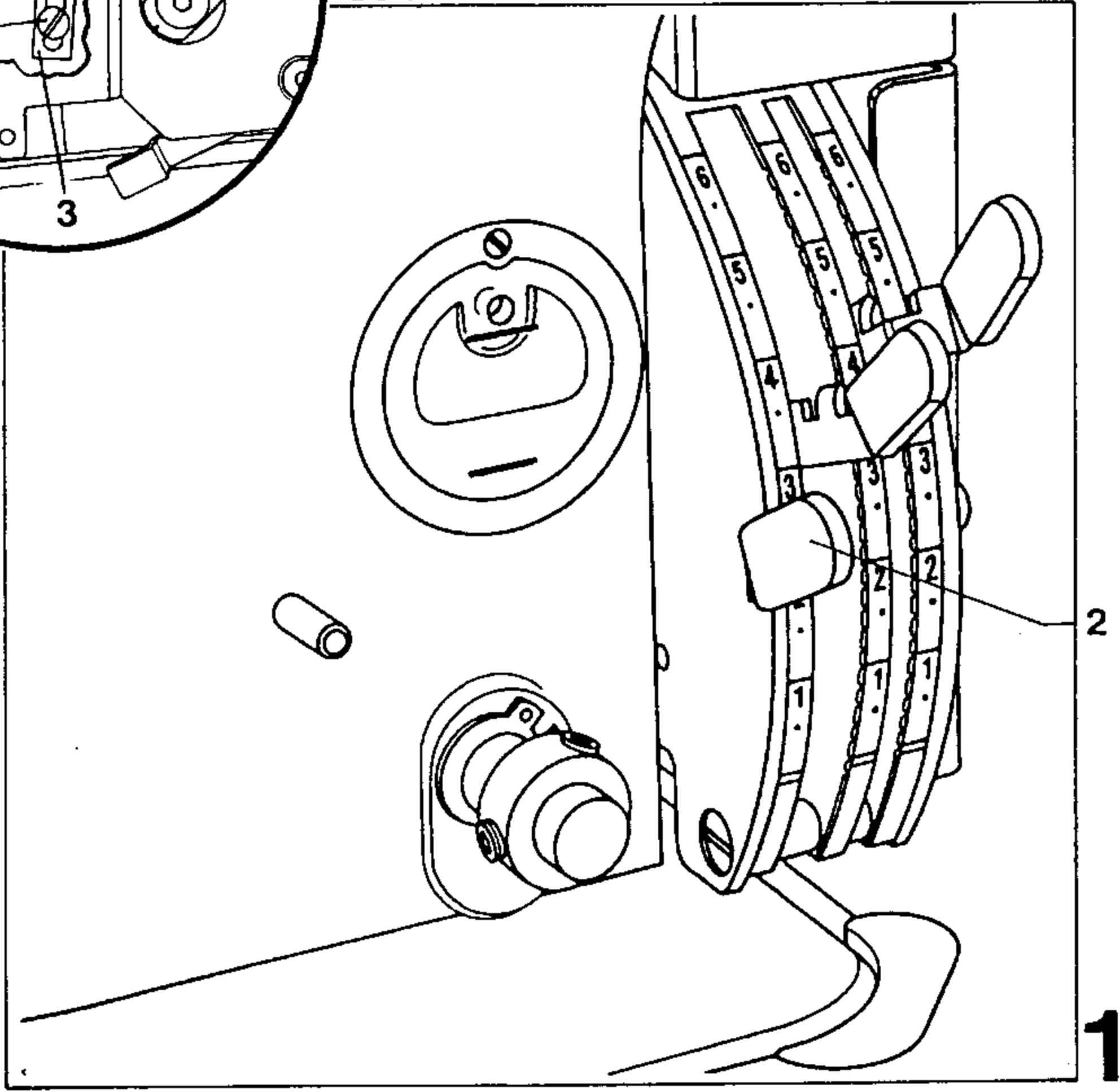

2

1

32 Automatic presser foot lift

The clearance between raised presser foot and needle plate must be 7 mm.

Raise presser foot with lifting lever and place a gauge of 9 mm between presser foot and needle plate.

Loosen screws 1 (Fig. 1).

Extend cylinder 2 (Fig. 2).

(With machine removed: connect compressed air to cylinder.

With machine fitted: switch on machine and press key .

Press crank 3 (Fig. 1) in the direction indicated by the arrow until lifting lever 4 (Fig. 3) rests against block 5.

In this position, tighten screws 1 (Fig. 1).

Remove gauge from under the presser foot.

Lower presser foot, then raise it again by means of the automatic presser foot lift.

In this position, the clearance between presser foot and needle plate must be 7 mm and the hand lifting lever must drop by its own weight.

33 Proximity switch of automatic presser foot lift

With the presser foot lowered, switch vane 6 (Fig. 4) must be above the proximity switch.

Loosen screw 7 and adjust switch vane 6 with the presser foot lifting cylinder retracted so that the vane is above the proximity switch at a distance of 0.5 mm.

Tighten screws 7 again.

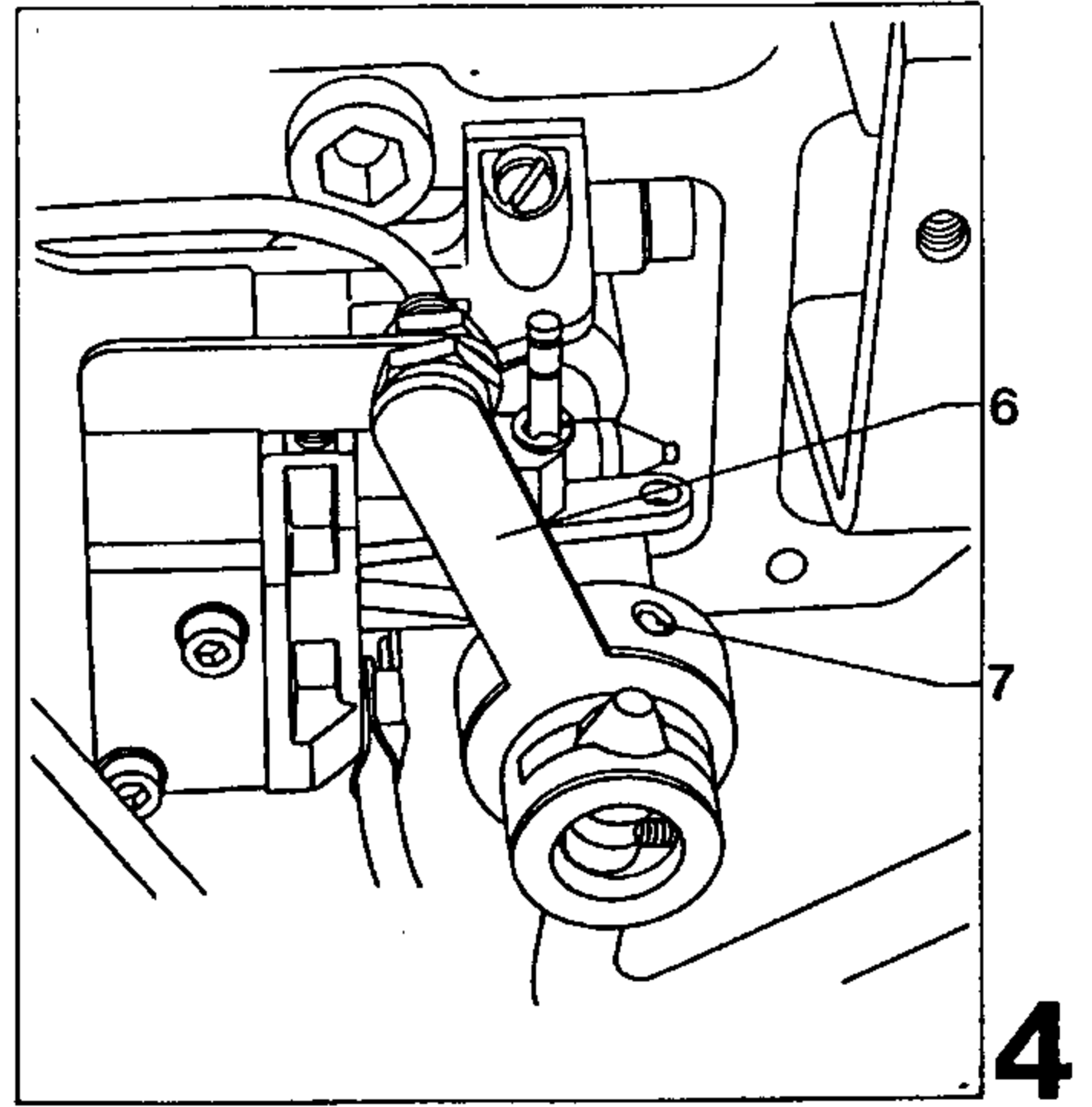
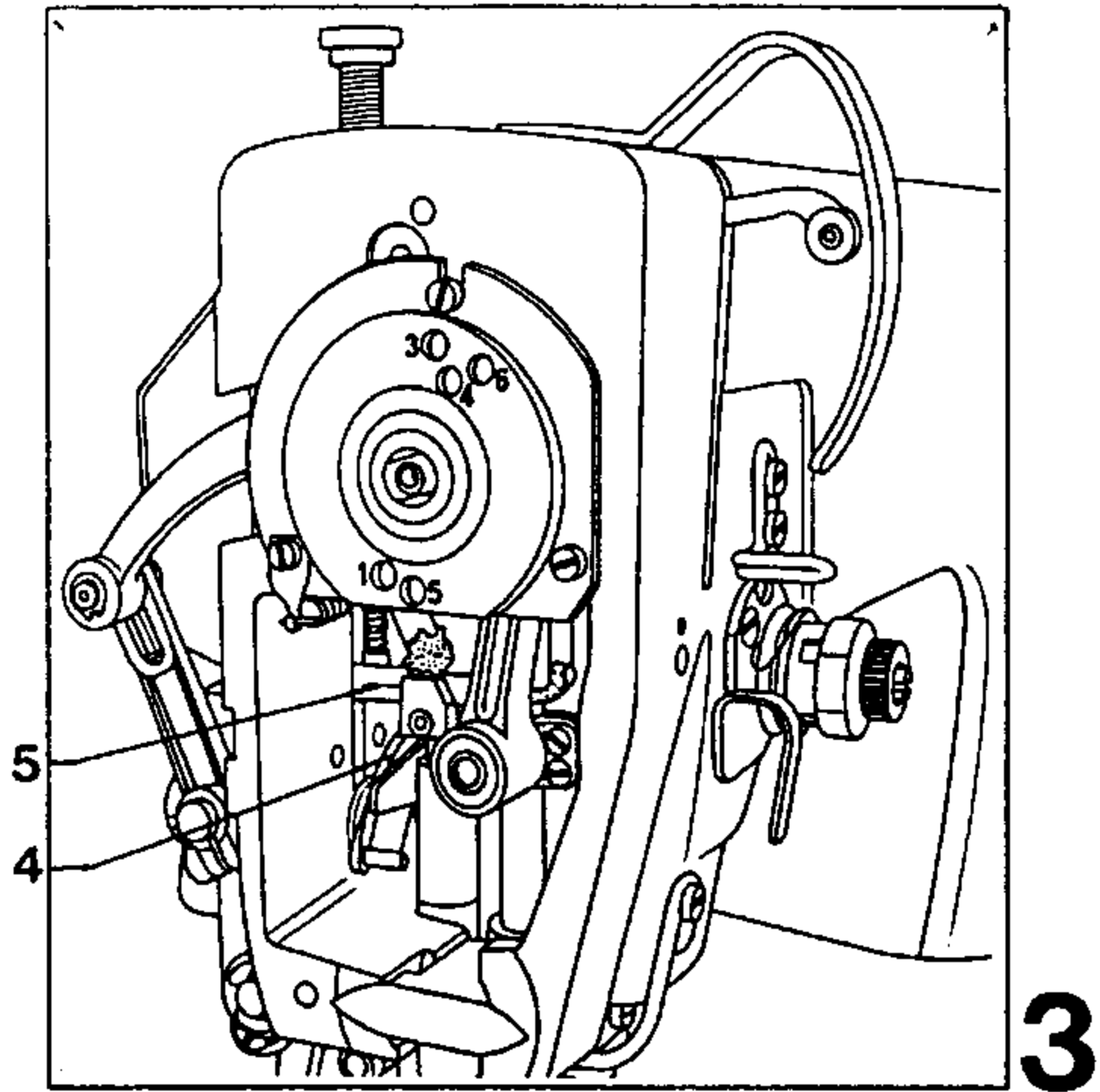
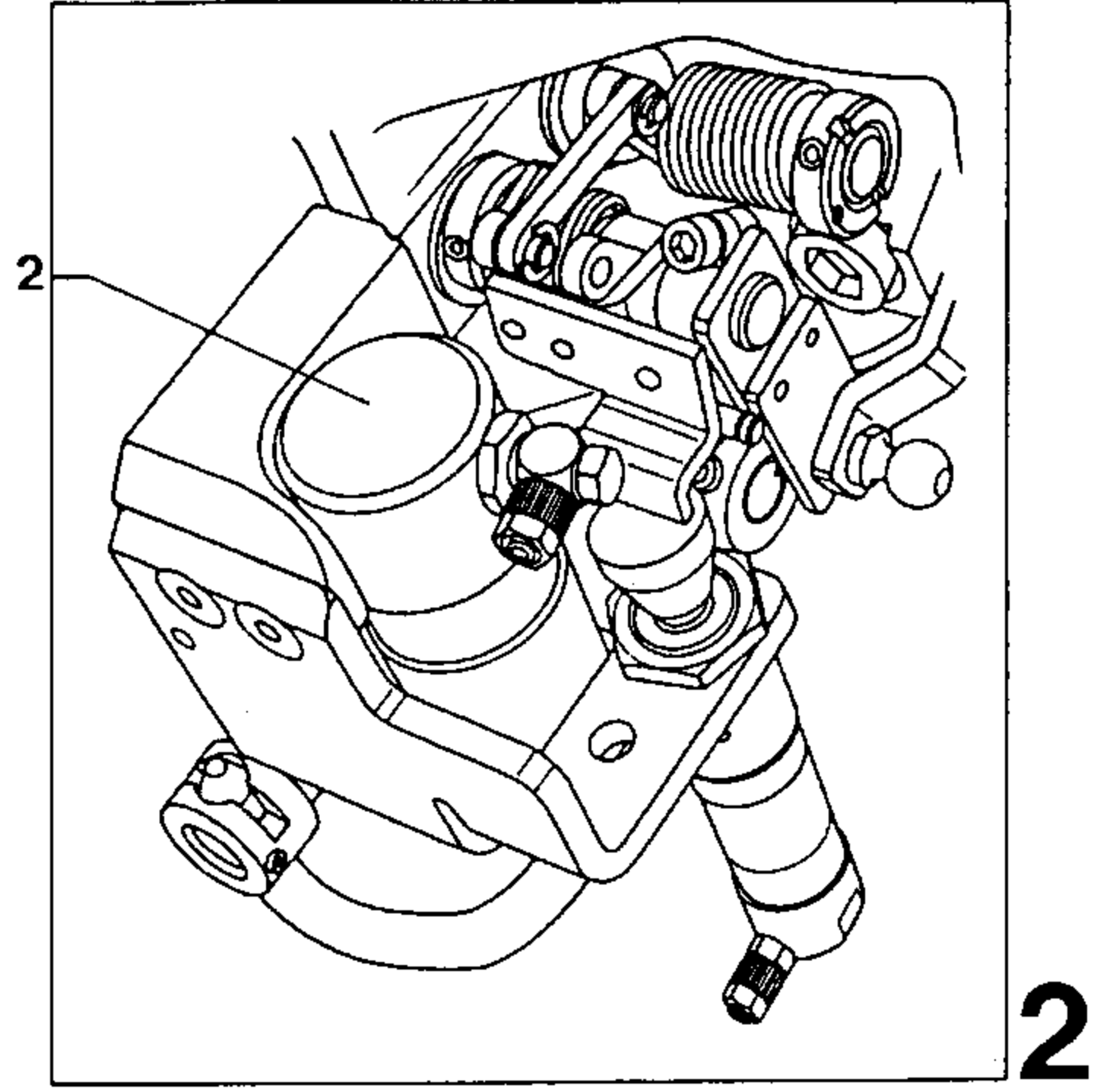
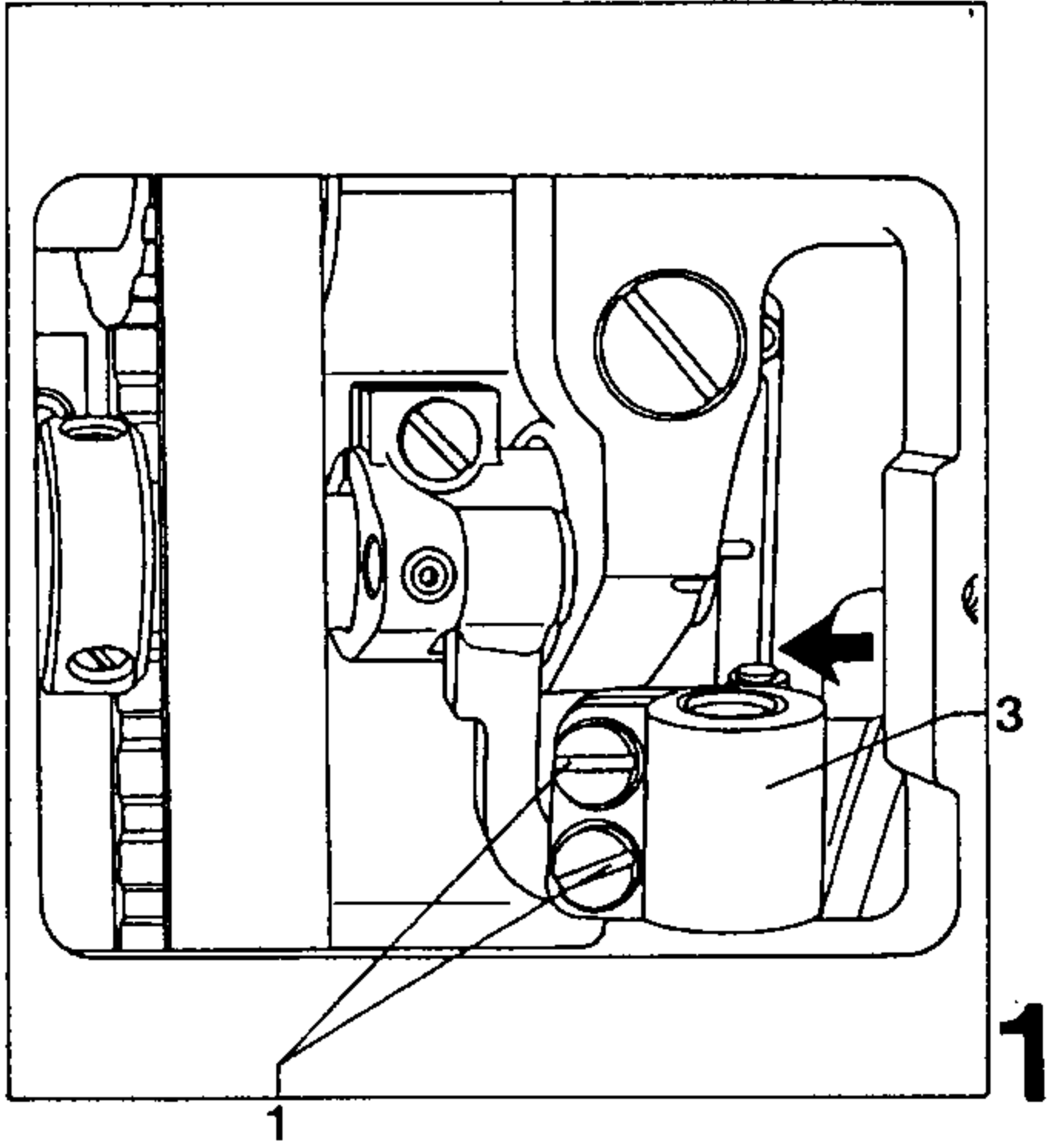

34 Proximity switch at thread trimmer

With the thread trimmer at rest position, trip 1 (Fig. 1) must be above proximity switch 2 at a distance of 0.5 mm.

Loosen nuts 3 and adjust proximity switch 2 accordingly.

Tighten nuts 3, making sure there is a distance of 0.5 mm between trip and proximity switch.

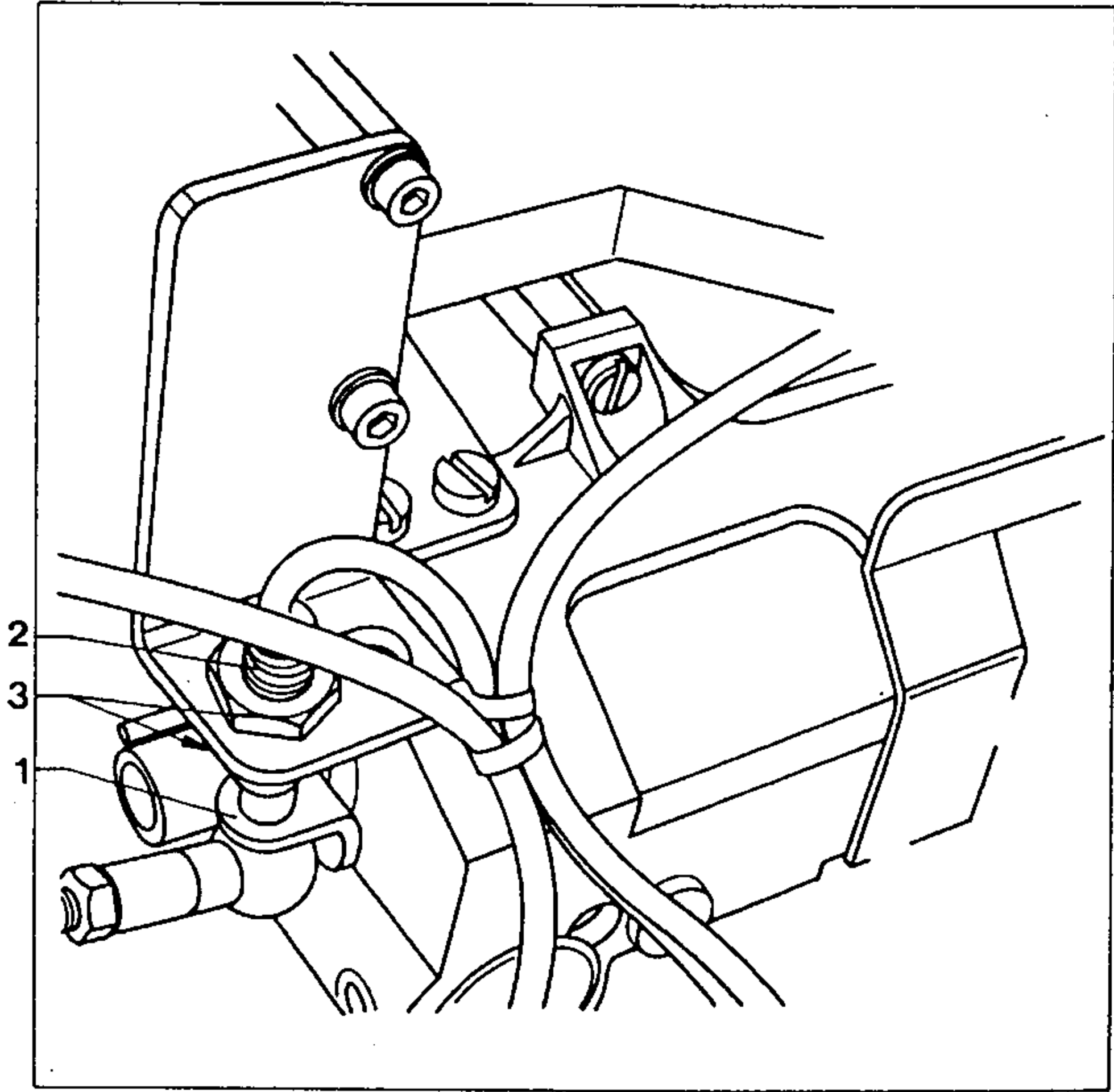

1

35 Take-up lever

Dismantling

Take out screws 1.

Loosen screw 2.

Pull off bearing plate 3 together with crank 4.

Loosen screws 5.

Pull out bearing pin 6 with an M4-screw (of the housing cover), pressing against take-up link 7.

Unscrew cover plate 8.

Loosen the clamp screws in arm shaft crank 10 through hole 9.

Set the needle bar at its approximate b.d.c.

Carefully pull off take-up lever 11 together with needle bar connecting rod 12, holding them parallel.

Refitting

Push take-up lever 11 together with needle bar connecting rod 12 in arm shaft crank 10 and on the needle bar stud.

Move take-up link 7 up, insert pin 6, and tighten screws 5 securely.

Turn the arm shaft so the needle bar is at b.d.c.

In this position, turn crank pin 13 so that its lobe faces rear (see arrow in Fig. 1). Make absolutely sure the lobe is positioned as indicated!

Tighten the clamp screws in arm shaft crank 10 through hole 9.

Replace bearing plate 3 together with crank 4. It must be easy to turn the bearing plate back and forth, as otherwise take-up lever 11 will bind.

Tighten screws 1.

Tighten clamp screw 2 securely.

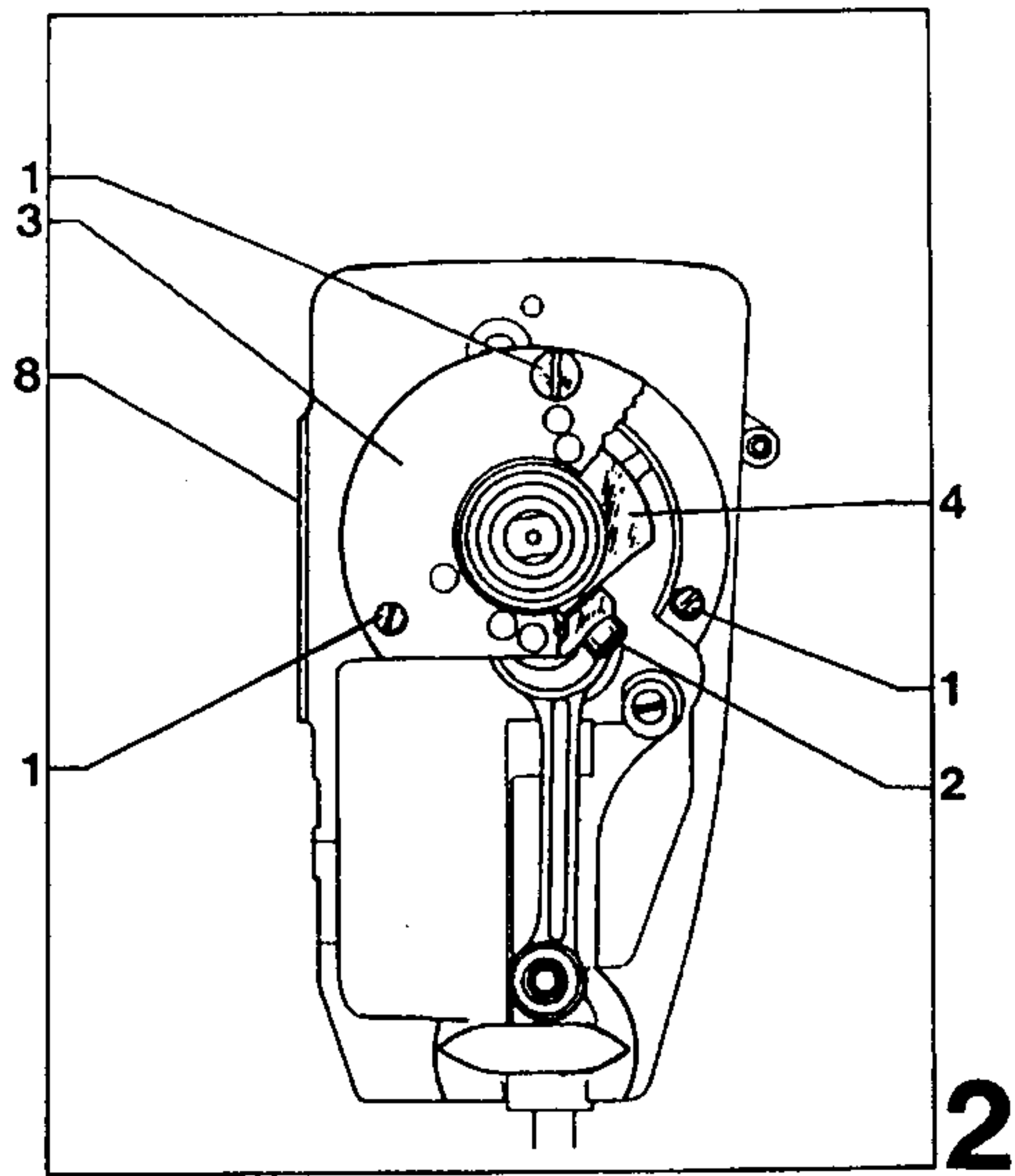
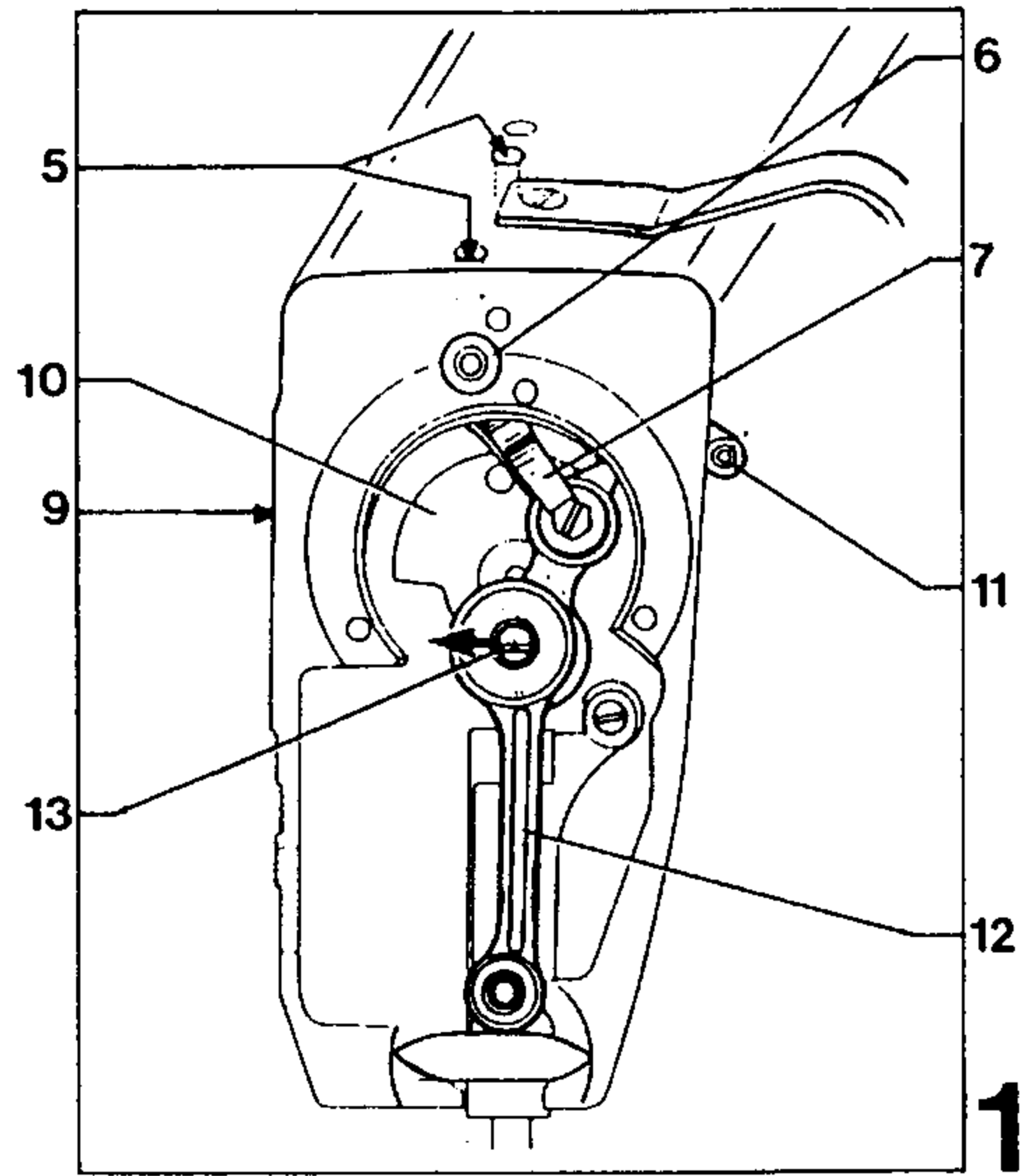

36 Fitting the sewing machine

Place the machine in its bearing in the table top.

Replace all pneumatic and electrical connections at the proper points (see section 4.2 "Removal of the sewing machine").

Replace V-belt.

Connect compressed-air hose to the air filter/lubricator.

37 Turning head

37.1 Adjusting the turning head

The distance between turning plate 1 (Fig. 1) and the needle must be the same in the entire turning area.

Switch off machine.

Raise presser foot with the lifting lever.

Set needle at its lowest position.

Press turning plate 1 with your hand on the table top.

Measure the distance between needle and turning plate.

Vary the position of the turning head by turning adjusting knob 2 (Fig. 2).

Measure the distance at every position.

In case of deviation, loosen screws 3 and 4 a little and adjust the whole turning head system.

Tighten screws 3 and 4 again.

37.2 Turning head pressure

Turning plate 1 (Fig. 2) must rest on the table top exerting light pressure.

Loosen screw 5 (Fig. 2) and press bush 6 down until turning plate 1 just touches the table top.

Tighten screw 5.

Loosen screw 7 and reposition retaining collar 8 according to the turning head pressure required.

- retaining collar up - pressure increased
- retaining collar down - pressure decreased.

Tighten screw 7.

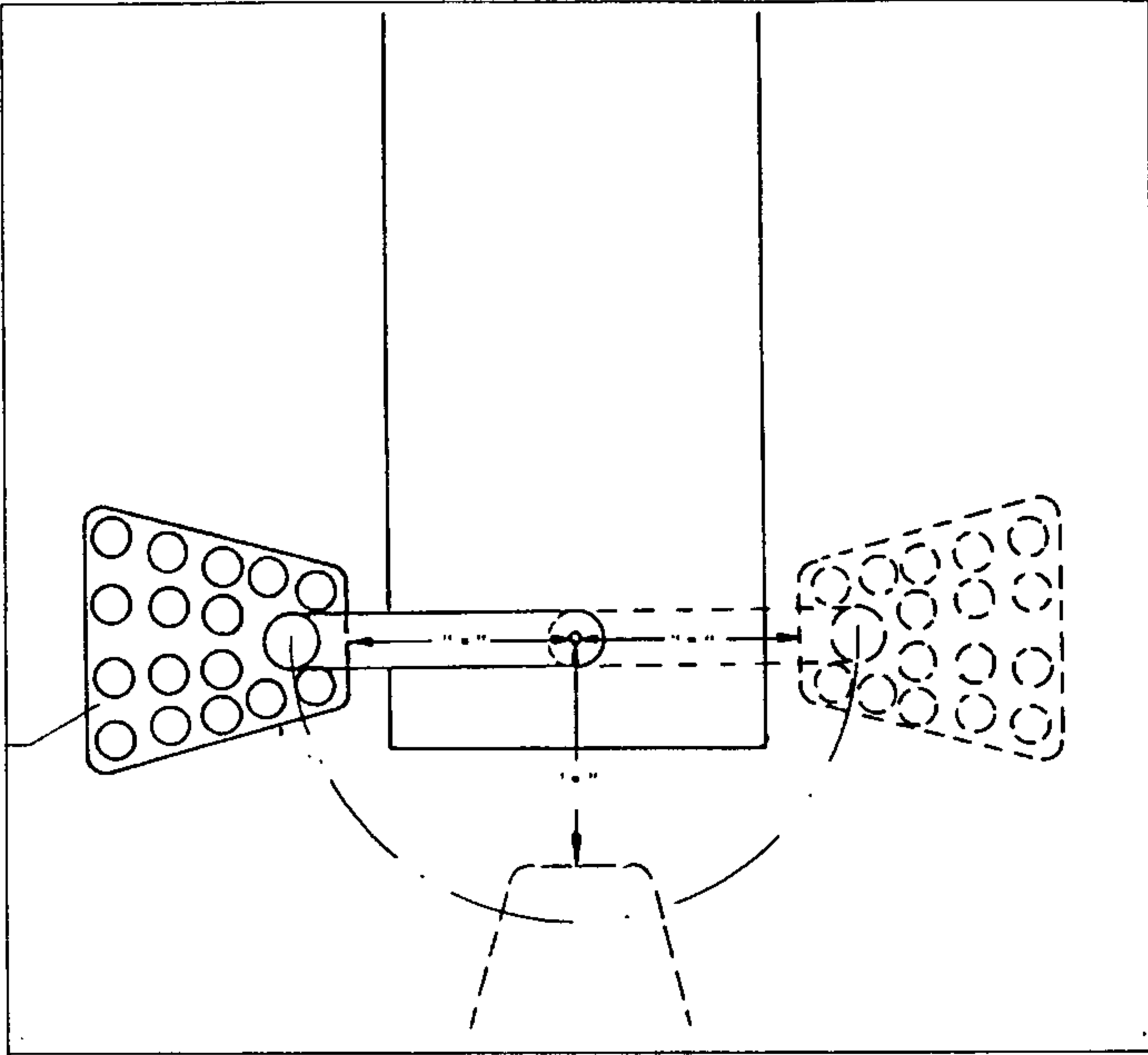

1

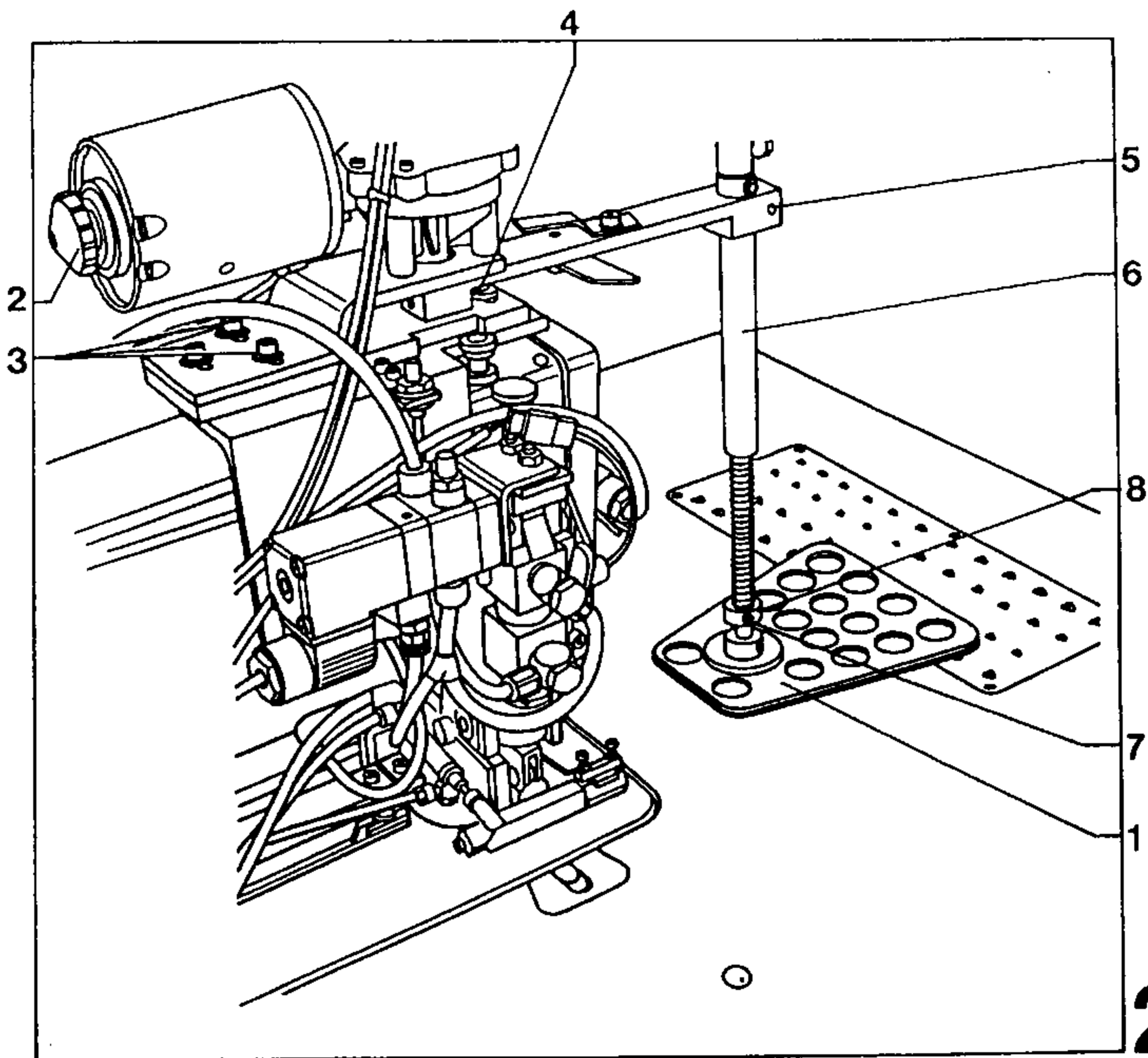

2

38 Photocell

Switching point:

- Crosswise to sewing direction about 2 mm before stop 1 (Fig. 1).
- In sewing direction about 18 mm before the needle.

During sewing, the turning head must turn the workpiece reliably against stop 1.

The vibrating presser at its front point of reversal must have no influence on the photocell.

38.1 Preliminary adjustment

Switch on machine.

Move a piece of paper under photocell 2 in sewing direction until the LED of the photocell goes out.

In this position, the front edge of the paper must be about 18 mm away from the needle.

Loosen screw 3, reposition the photocell in sewing direction accordingly, then tighten screws 3.

Move a piece of paper under the photocell crosswise to sewing direction until the LED of the photocell goes out.

In this position, the front edge of the paper must be about 2 mm away from the needle.

Loosen screws 4, reposition the photocell accordingly, then tighten screws 4.

38.2 Final adjustment

Switch on machine,

set selector switch 5 (Fig. 2) at AUTO and press key 6.

Enter the required program at the control panel.

Insert the workpiece.

Press the start key,

- the sewing procedure with turning runs off automatically.

During sewing, make sure that the workpiece is reliably turned against stop 1.

Re-adjust the photocell, if necessary.

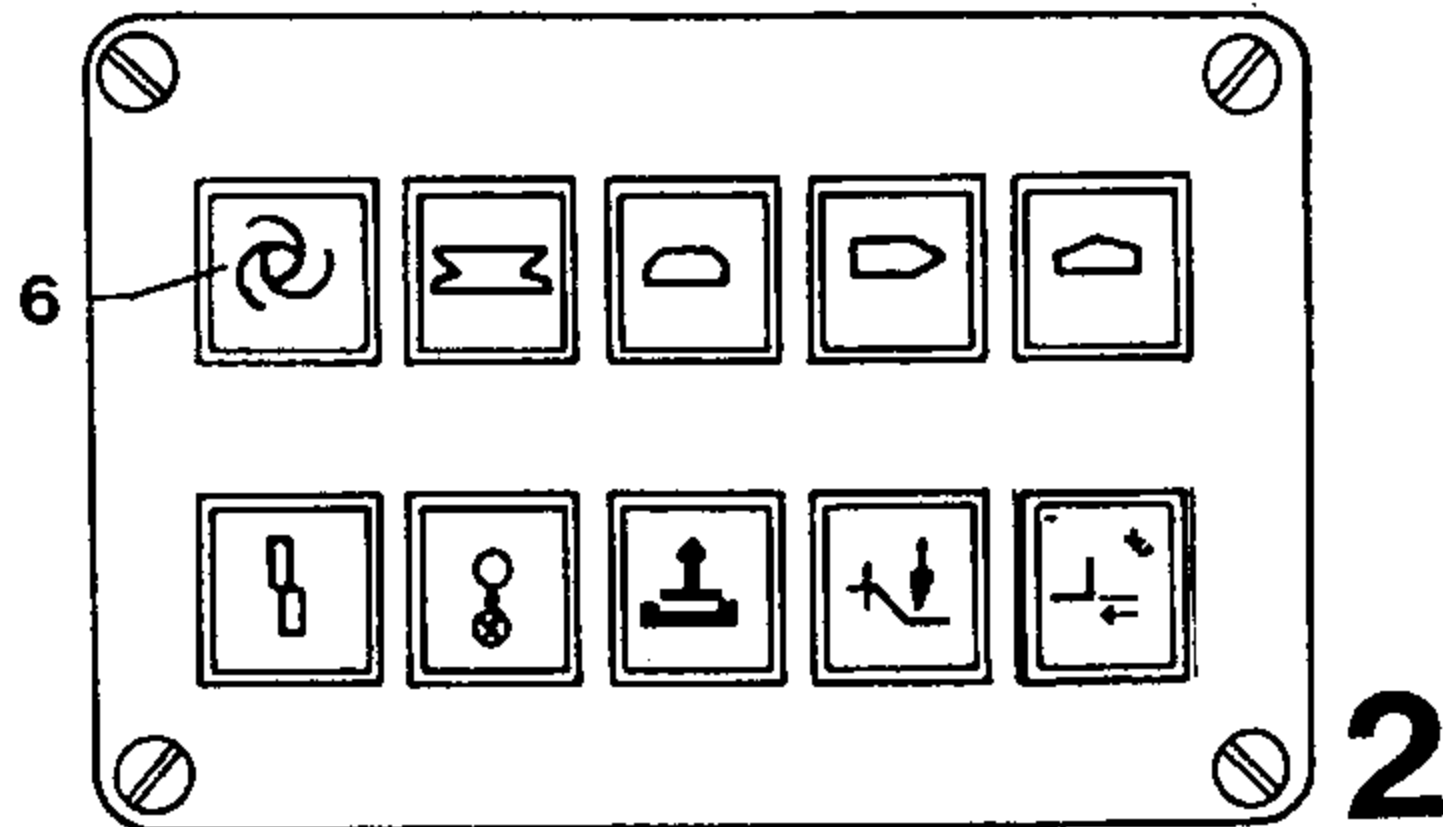
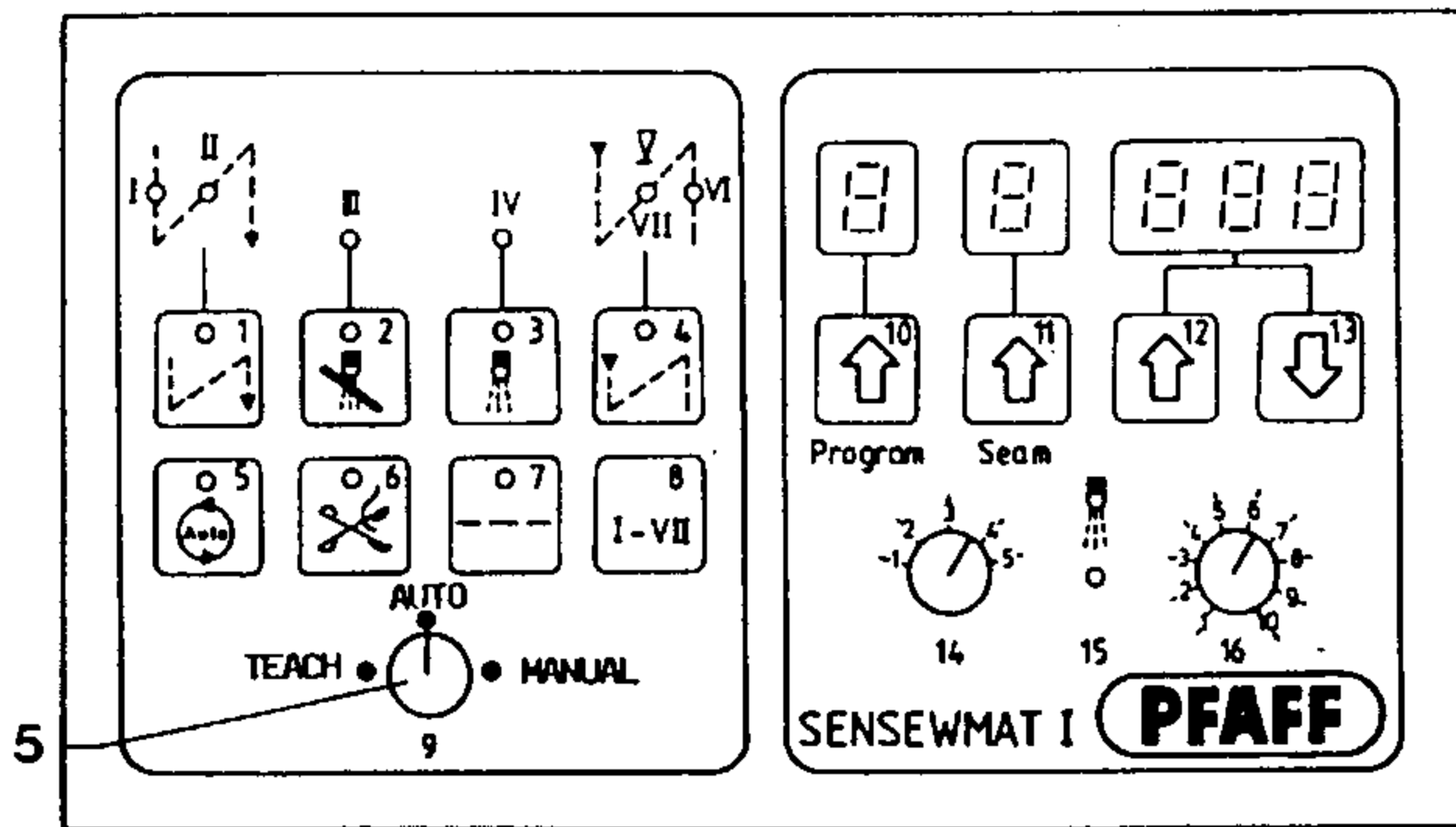
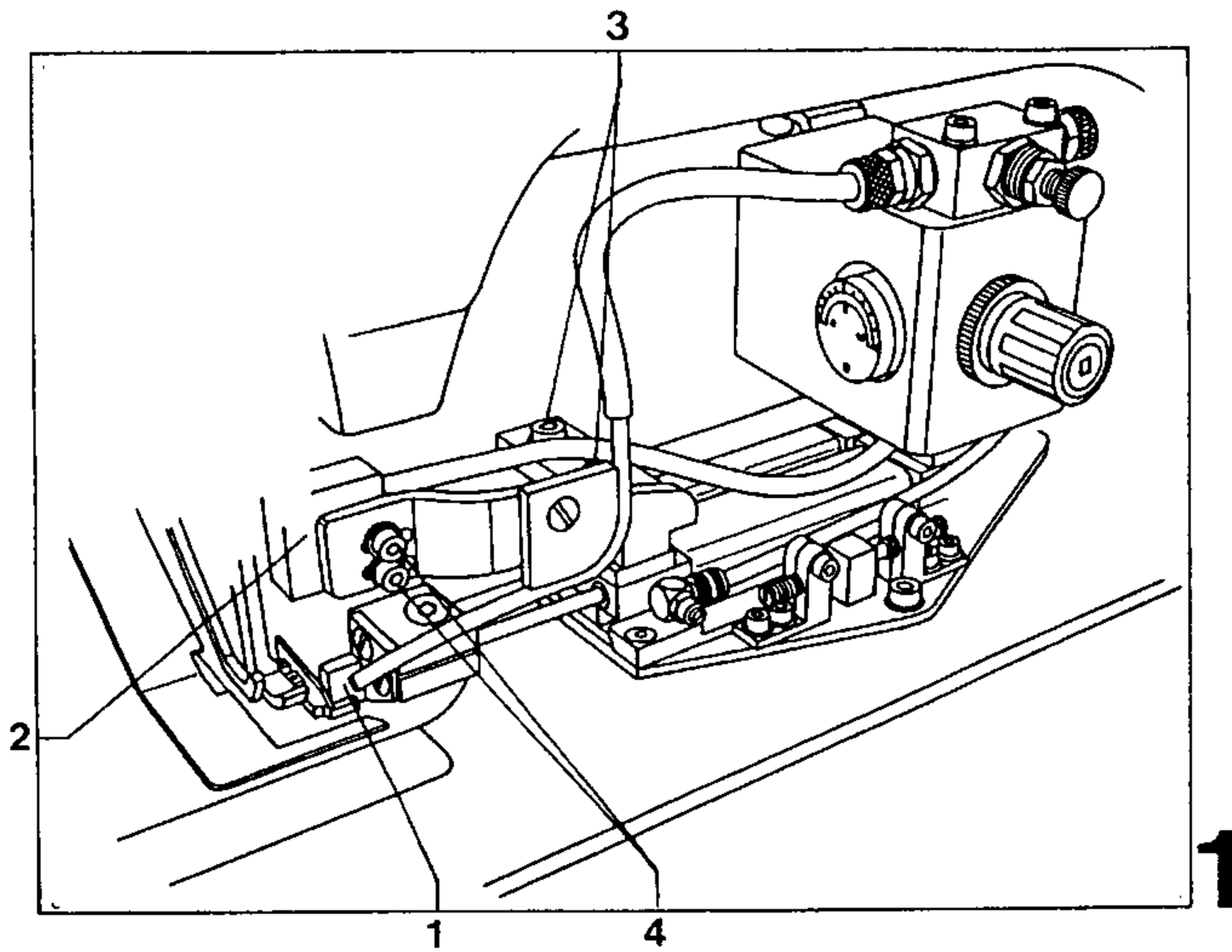

39 Proximity switches for turning head limitation

The turning head must turn through about 180°. Start and end positions must be on a line drawn through the needle center in sewing direction (Fig. 1).

Position "A"

Loosen screw 2 and re-position switch vane 1 (Fig. 2) so that the turning head moves to position "A" (Fig. 1).

Position "B"

The position is determined by the photocell at the machine head (see section 38).

Proximity switch 3 (Fig. 3) serves as a safety switch if the photocell does not signal the end position.

IMPORTANT:

Proximity switch 3 must not switch off the turning head before the latter has reached the position determined by the photocell.

Loosen screw 4 and adjust switch vane 5 accordingly.

39.1 Distance of proximity switches and switch vanes

The distance must be about 0.5 mm (Fig. 4).

Loosen nuts 6 and re-position accordingly.

Tighten the nuts again.

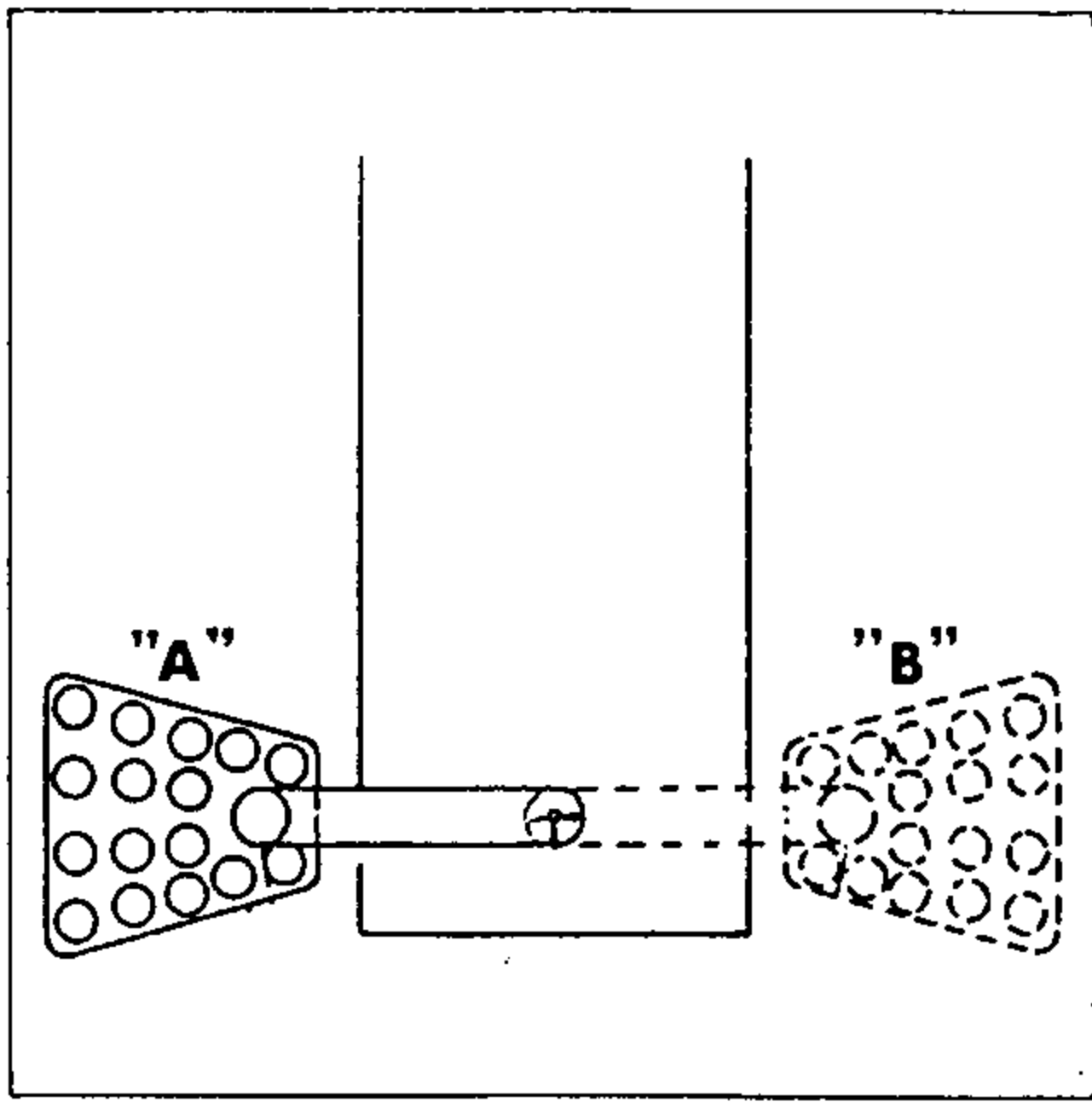

1

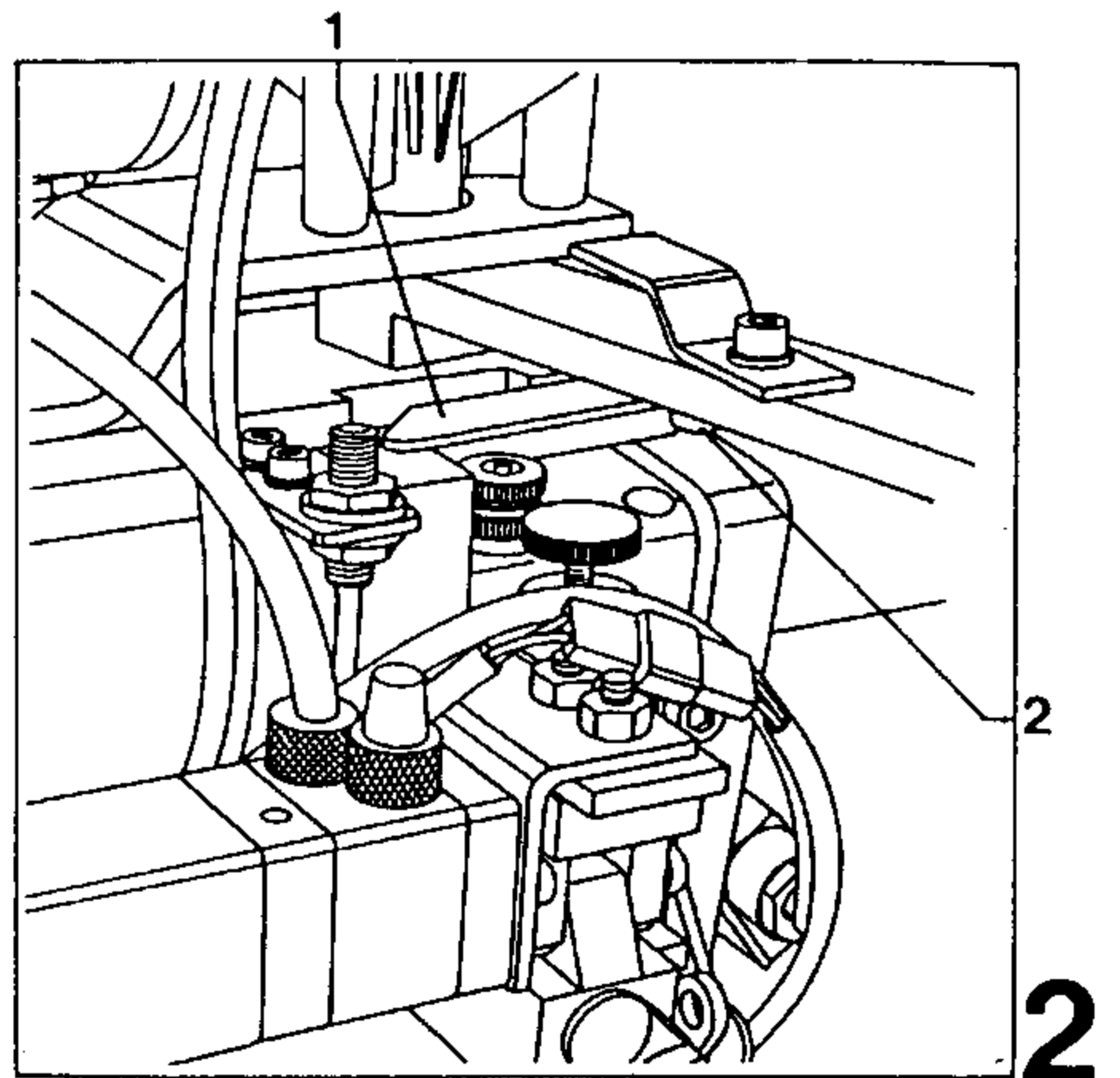

2

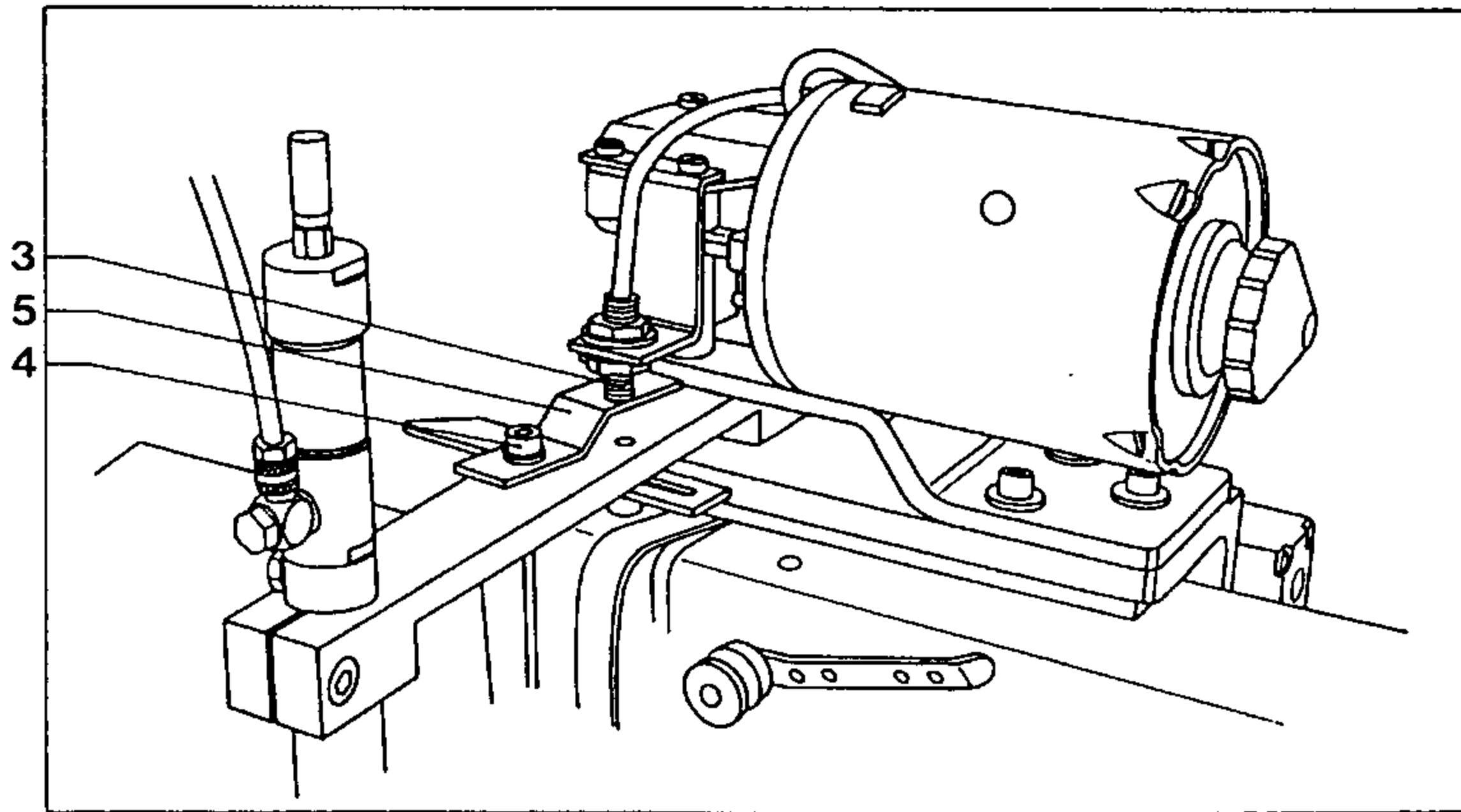

3

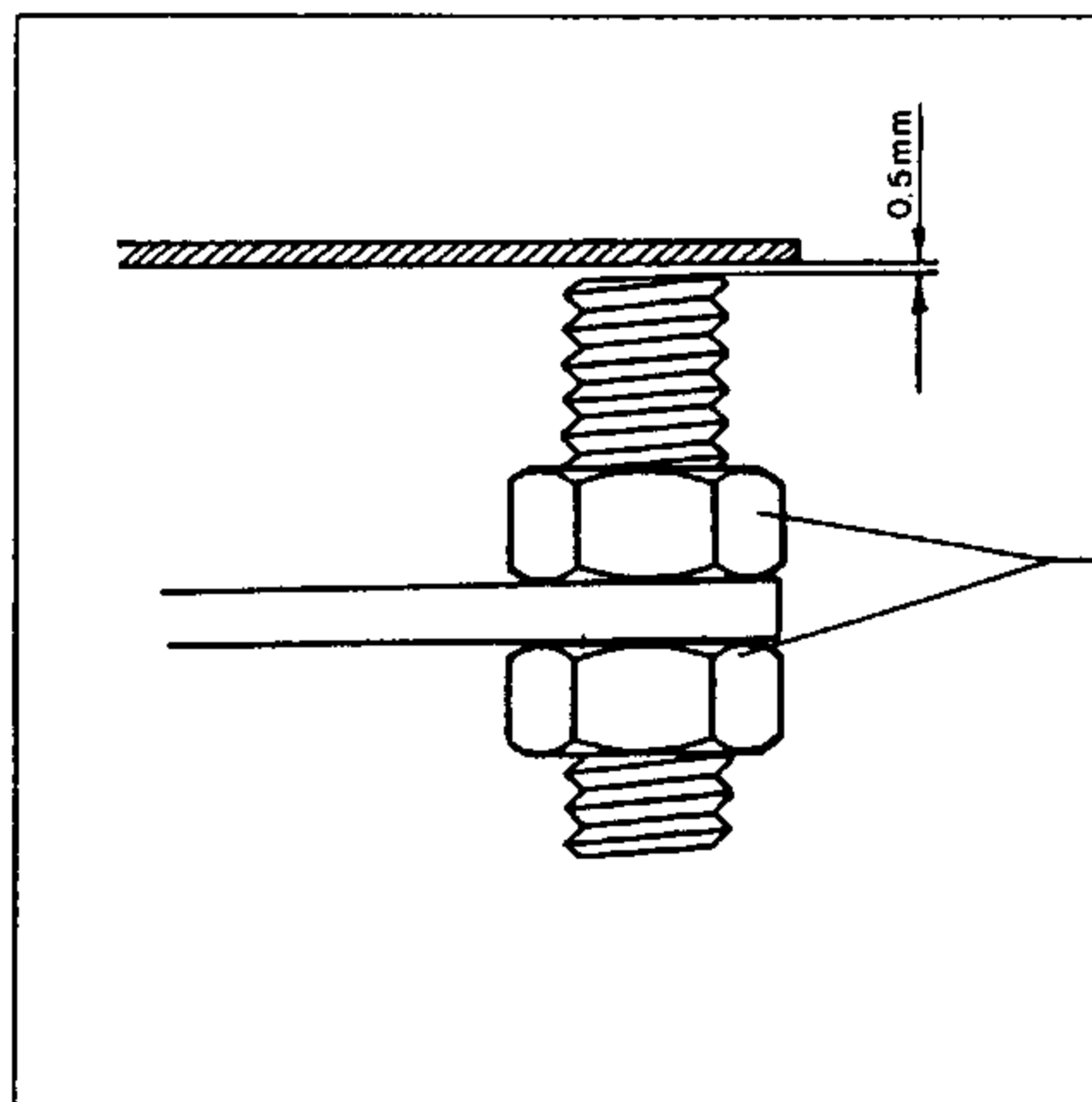

4

40 Potentiometers in the control box

40.1 Circuit board 11 (Fig. 1)

Potentiometer 1:

Time between photocell unblocked and "stacker feed" to left.

After thread trimming and presser foot up the sewn part must be fed to the stacker without delay.

Potentiometer 2:

Sensemat disturbance,

Time firmly set at the factory (do not change).

Potentiometer 4:

Time between "turning head down" and "turning to right" on. The turning motion must not start until the turning head is lowered.

Potentiometer 5:

Time between "turning head up" and "turning to left" on. The turning motion must not start until the turning head is raised.

Potentiometer 6:

Time between "sewing on" 1st seam and turning head position "center"; set potentiometer so that after the first seam is sewn, the turning head gets a reliable hold for turning all workpiece shapes to be processed.*

* On machines having potentiometer 7 (Fig. 2) on the control panel, potentiometer 6 (Fig. 1) must by all means be set at "0". The time between "sewing on" and "turning head position center", i.e. the point of time of the position at which the turning head takes over the workpiece for turning after the first seam has been sewn must be set at potentiometer 7 (Fig. 2) in such a way that the turning head touches the workpiece over its entire width.

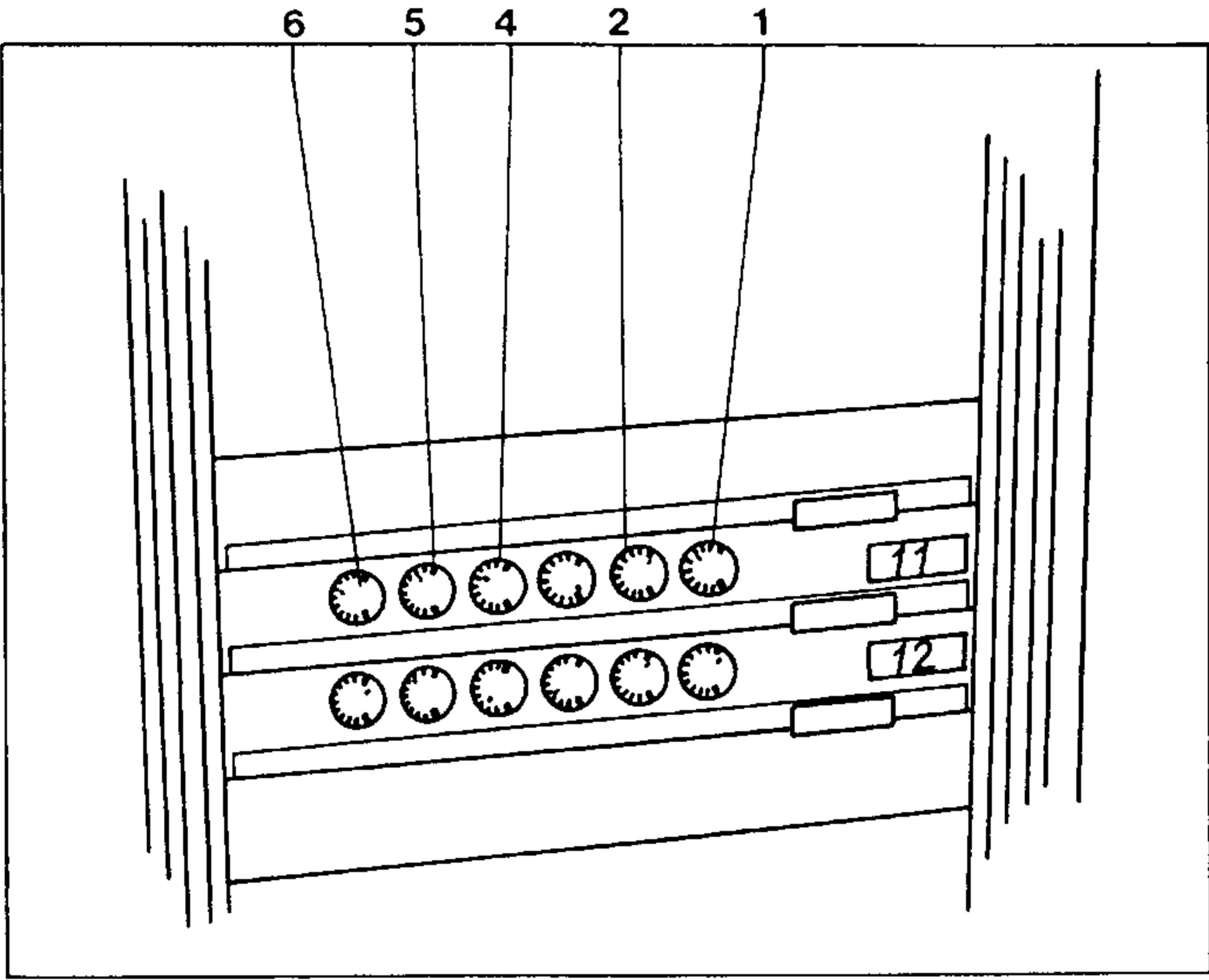

1

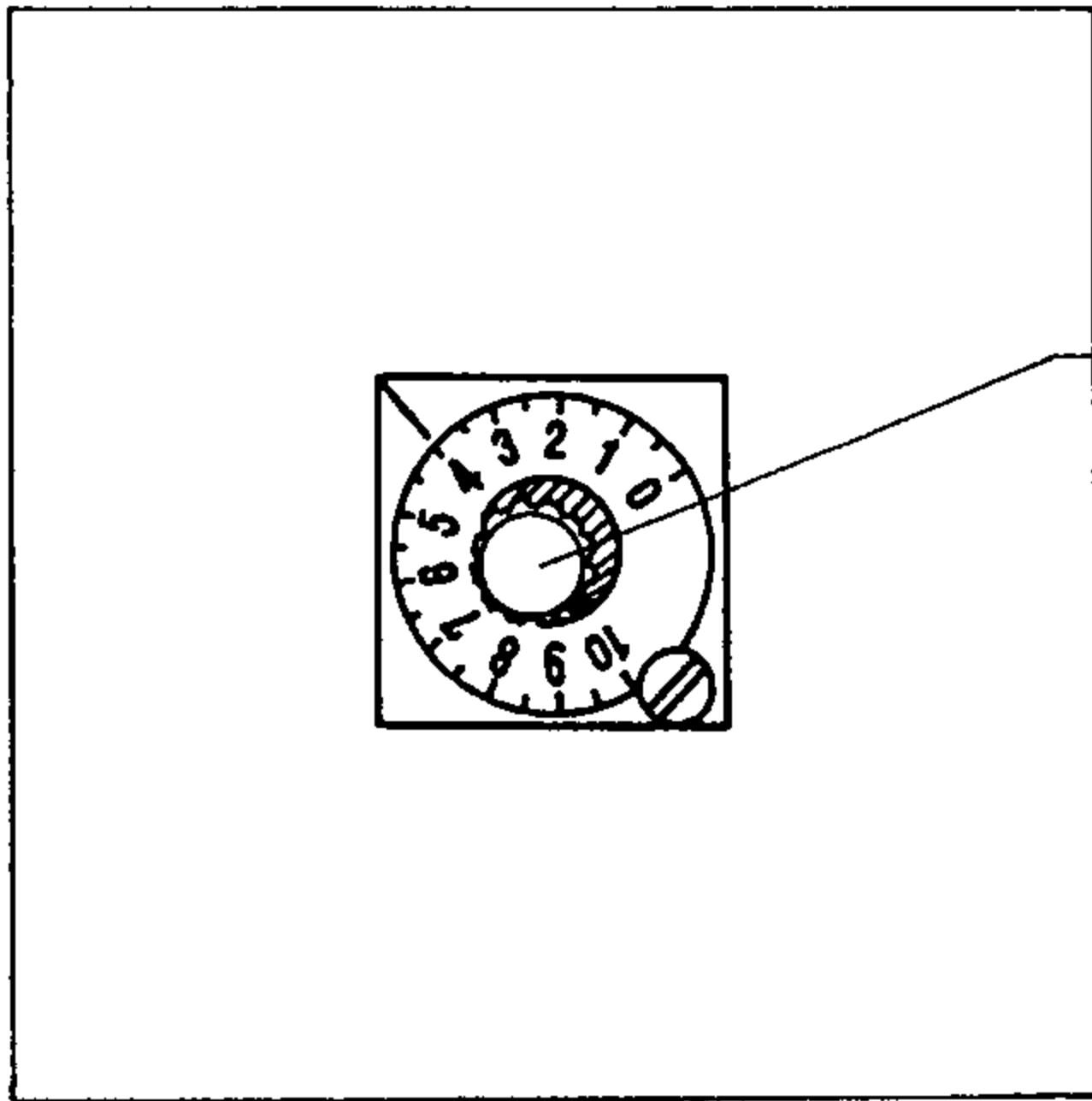

2

40.2 Circuit board 12 (Fig. 3)

Potentiometer 1:

"Stop 8 (Fig. 4) forward" 1st seam, in program "one-piece collar" time between "sewing start" and "stop 8 forward".

"Stop 8 forward" must not set in until the collar stand is fed out of the stop area.

Potentiometer 2:*

"Stop 8 backward" 3rd seam, in program "one-piece collar" time between "sewing start 3rd seam" and "stop 8 backwards".

"Stop 8 backward" must be finished when the collar stand is fed to the stop area.

Potentiometer 3:

Reset stacker.

Time between "stacker start" and "stacker rest position".

The time must be set so that the stacker executes its complete stacking function without time delay.

Potentiometer 4:

Time between "stacker slide left" and "stacker start". Stacker start must not be effected until the workpiece fed in is fully in the stacker.

Potentiometer 5:

"Stop 9 (Fig. 4) back" 3rd seam, in program "one-piece collar" time between "sewing start 3rd seam" and "stop 9 backwards".

Stop 9 must go back when the collar stand is fed into the stop area.

Potentiometer 6:

Loading guide 10 (Fig. 5) down (after sewing end).

The loading guide must go down as soon as the stacker slide has fed the workpiece sewn out of the loading area.

* Adjust this potentiometer after potentiometer 5 has been adjusted.

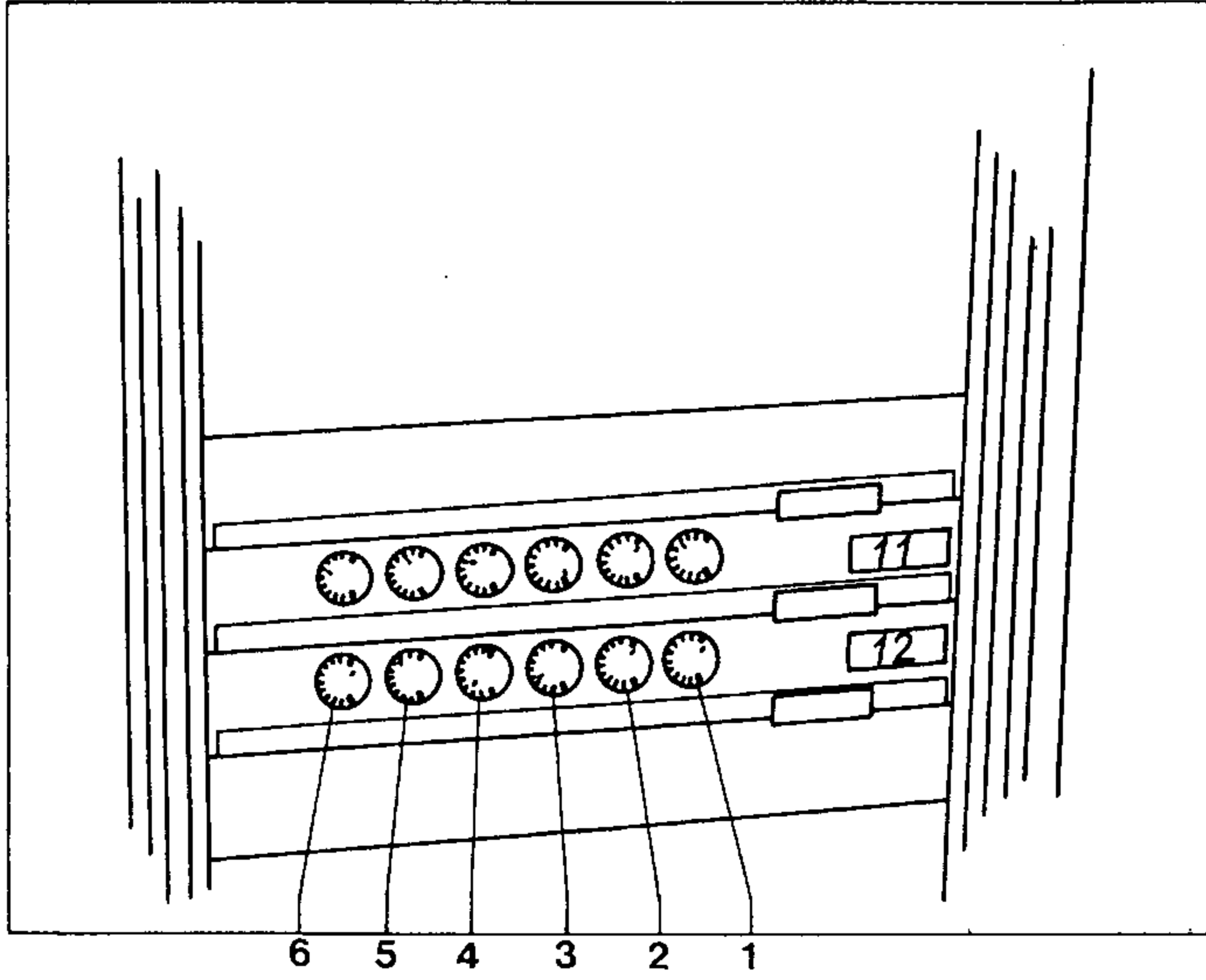

3

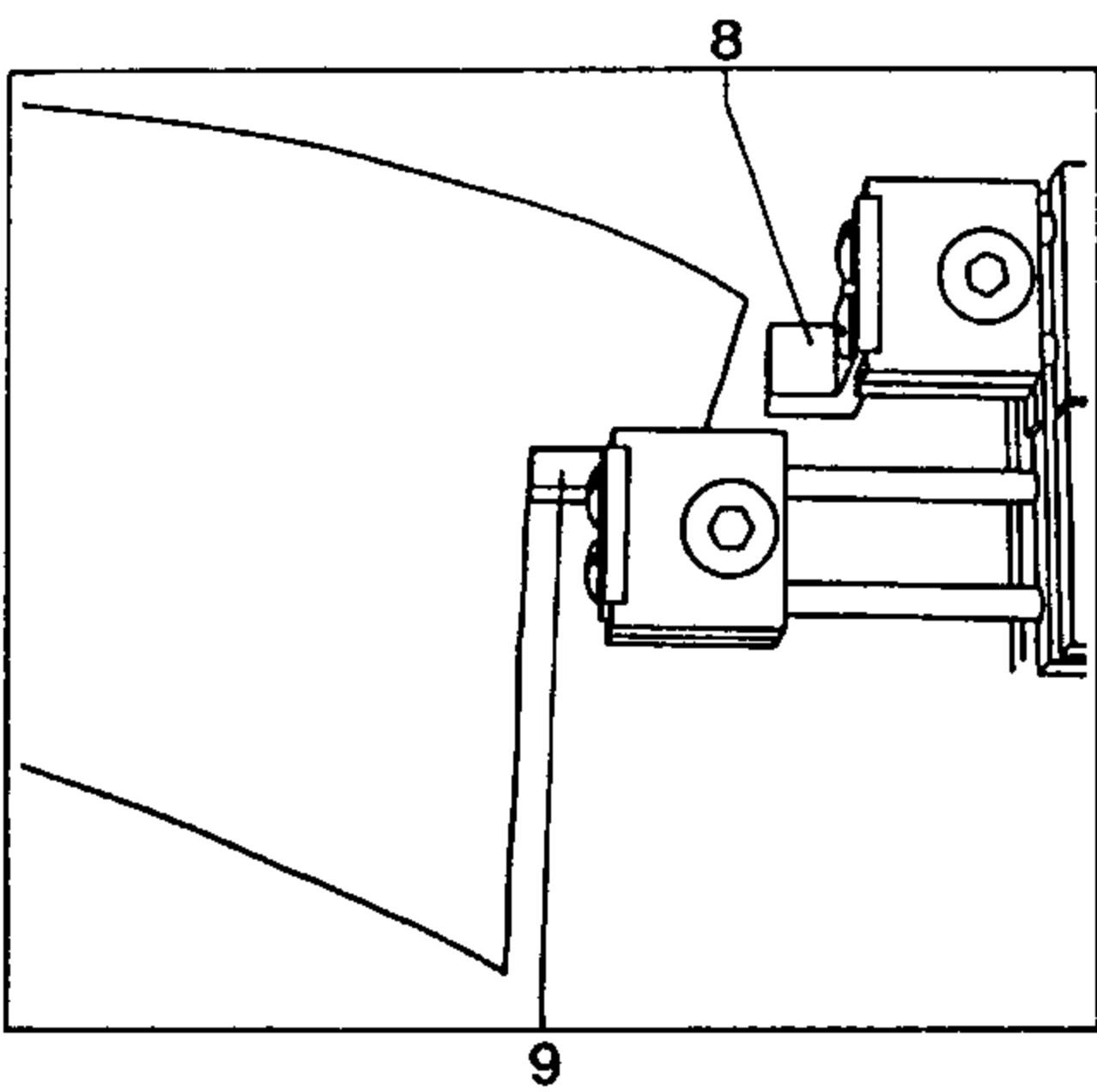

4

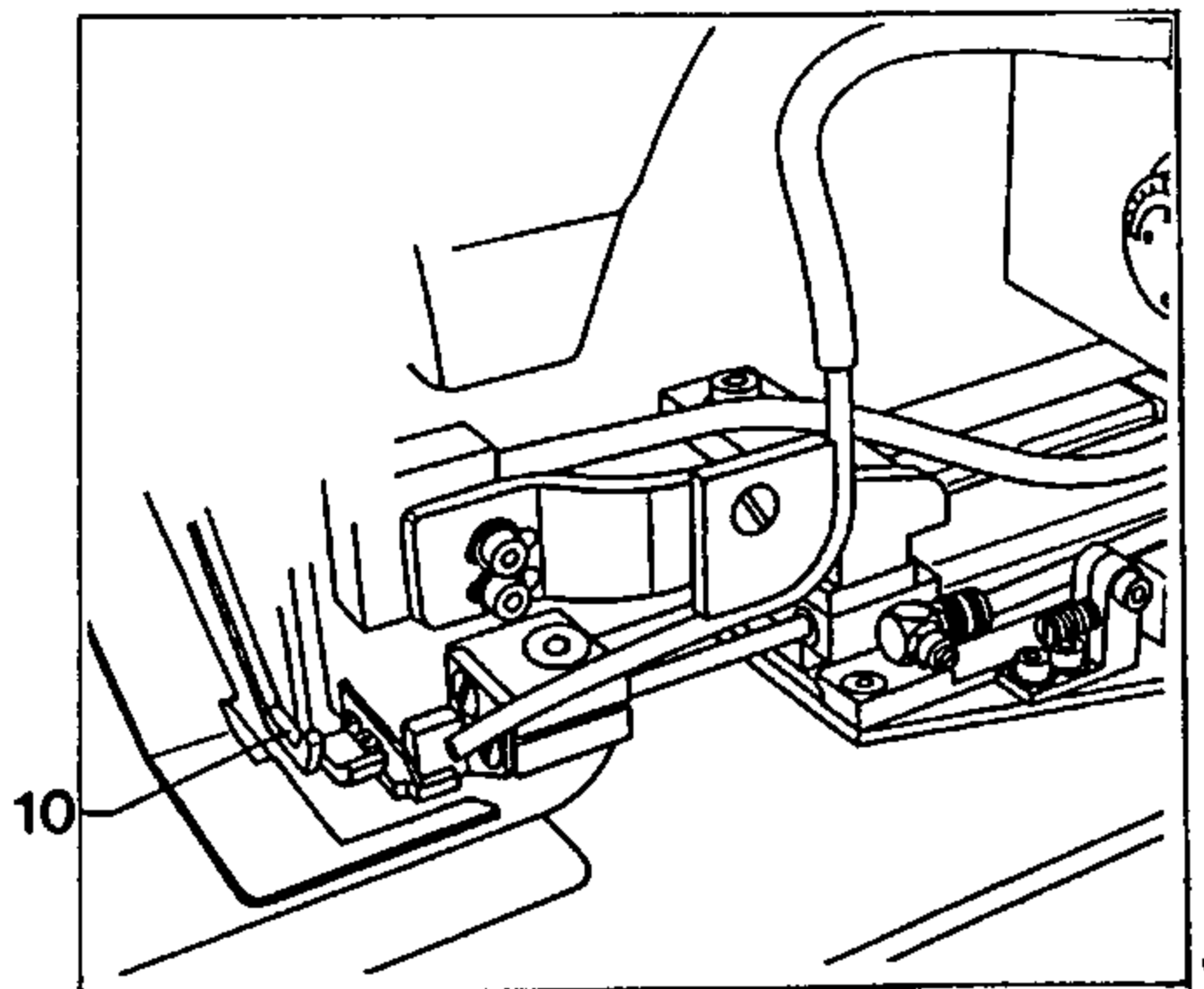

5

41 Work at the air filter/lubricator

Regularly check the air filter/lubricator so that disturbance-free operation can be ensured.

41.1 Draining the water trap

For max. water level, see marking at container 1 (Fig. 1).

Open drain screw 2.
Drain water.
Close drain screw 2.

41.2 Cleaning the air filter

Clean the filter when a working pressure of 6 bar is no longer attained.

Shut off compressed air.
Unscrew container 1.
Unscrew separating plate 3.
Take out filter 4.
Clean filter and container with naphtha.
Blow through the filter with compressed air from the inside.
When re-assembling, do not forget the gasket!
Open compressed air.

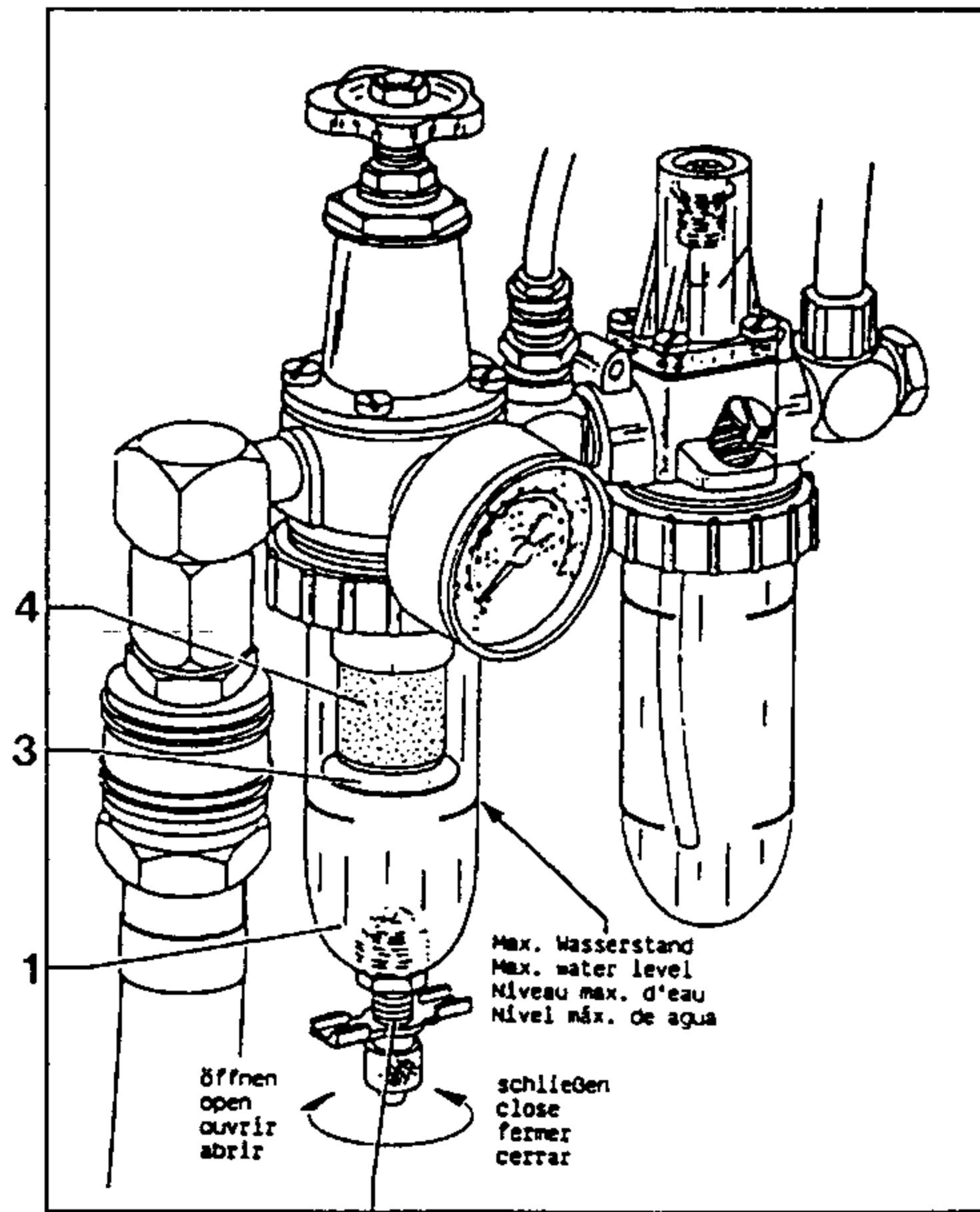

2

1

41.3 Topping up oil

For correct oil level, see markings at container 5 (Fig. 2).

We recommend Pfaff oil, part No. 280-1-120 144, or another oil suitable for pneumatic systems, which causes little or no swelling or shrinking of the sealing materials used, under different operating conditions.

The mean viscosity of this oil should preferably be between 22.0 and 46.0 mm²/s at 40° C, and its density between 0.865 and 0.875 g/cm³ at 15° C.

Shut off compressed air.

Check container 5 for dirt (residue).

If necessary, unscrew container 5 and clean with naphtha.

Screw on container 5 again (do not forget gasket!).

Take out screw 6.

Fill in oil (note markings!).

Replace screw 6.

Open compressed air.

41.4 Drip feed rate at vaporizer jet

Adjust drip feed rate so that sufficient lubrication of cylinders and valves is ensured.

Turn regulating screw 7 accordingly.

41.5 Cleaning the vaporizer jet

Shut off compressed air.

Unscrew vaporizer jet 8.

Fully open regulating screw 7.

Blow through vaporizer jet 8 with compressed air in the direction of the arrow (Fig. 2.1).

Screw on vaporizer jet (do not forget gaskets!).

Open compressed air.

Re-adjust drip feed rate.

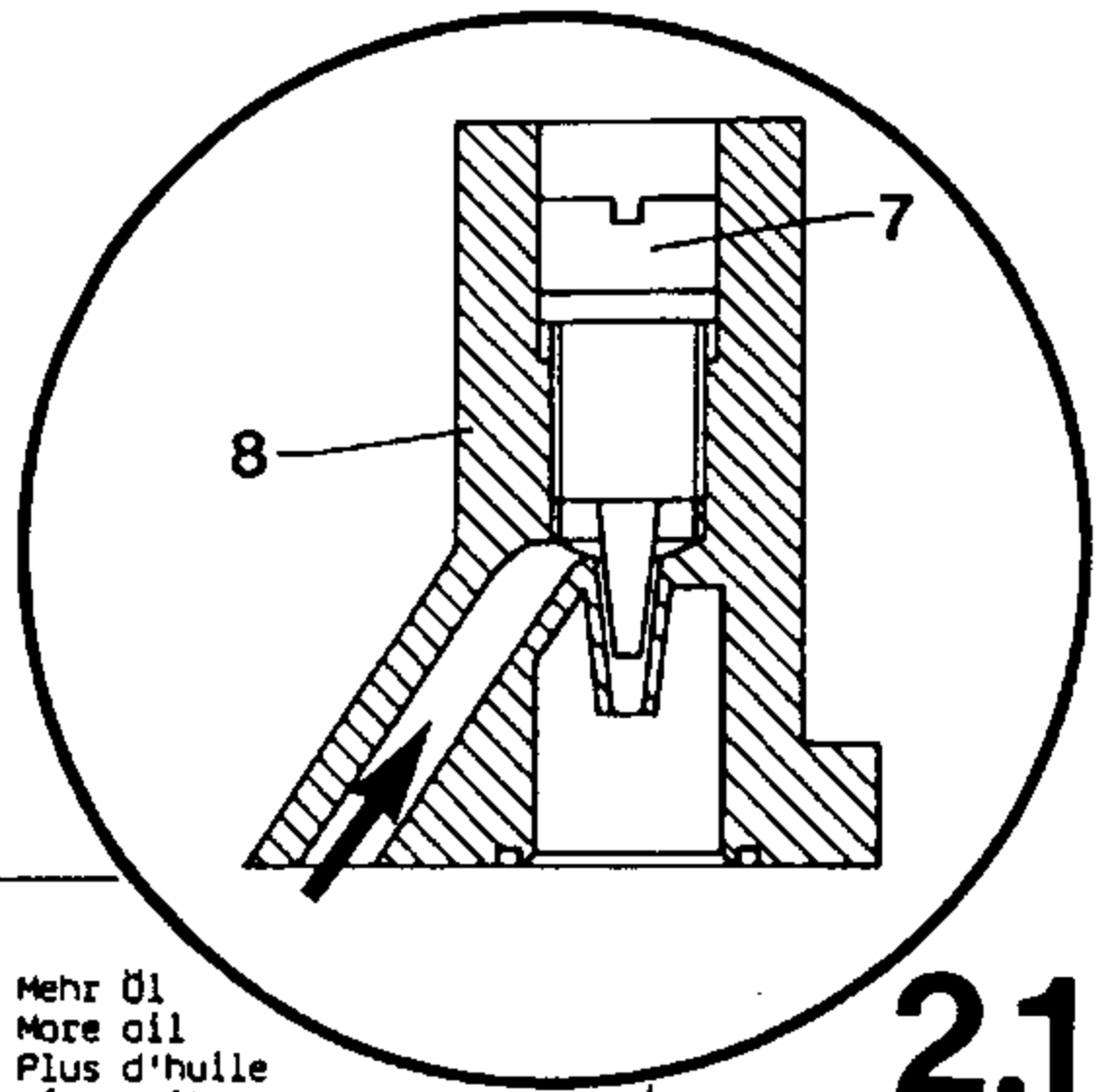

2.1

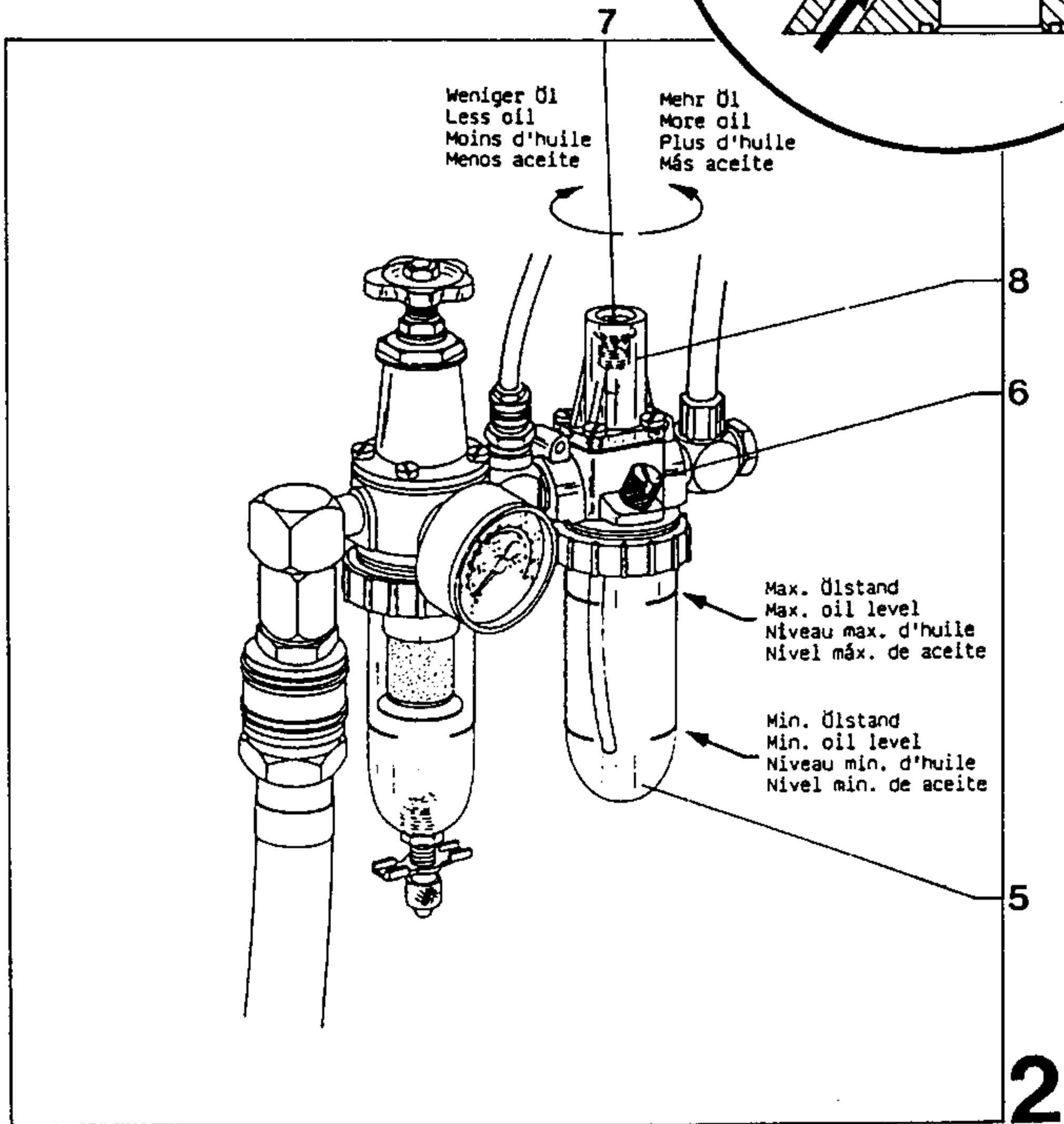

Edge guides

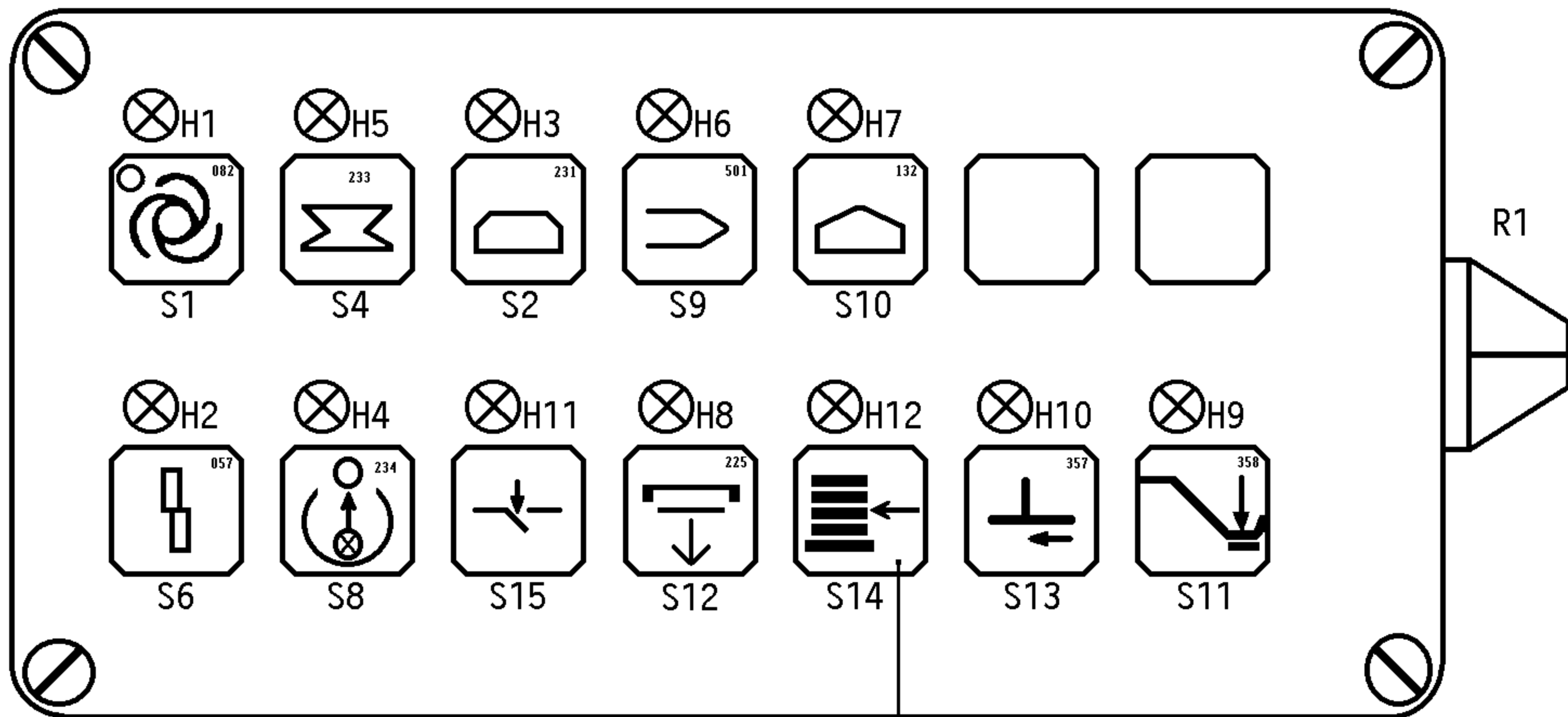
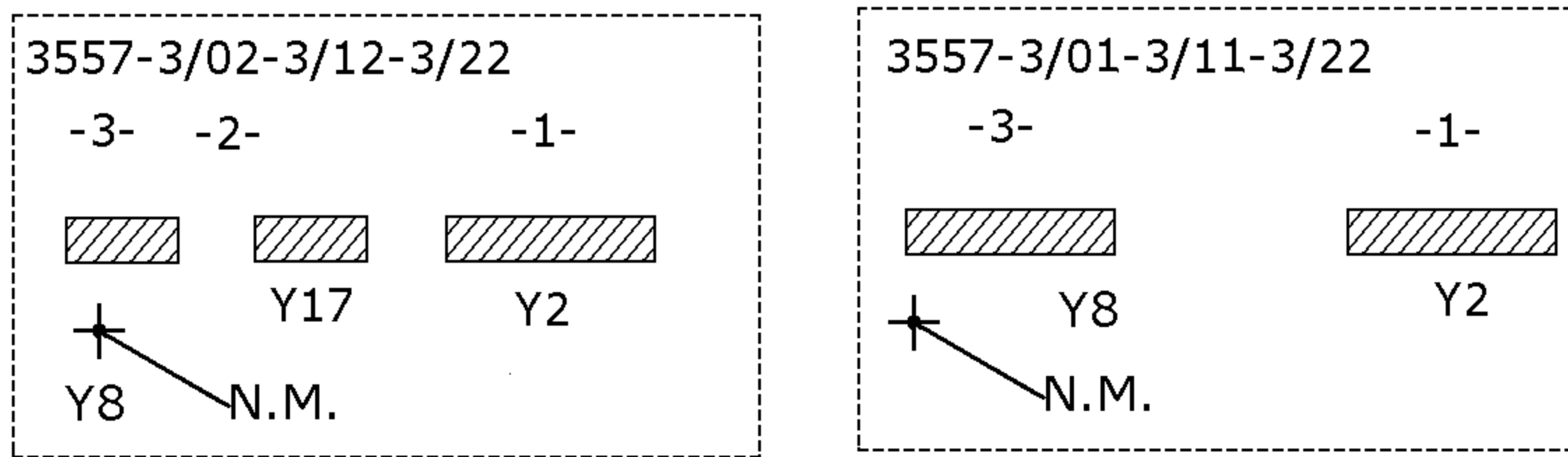

- b20. = Sub D 15pin B13, B15, B16
- b21. = Sub D 15pin S3, B9, B10, B11, B12, B21
- b22. = Sub D, 15pin, sewing head
- b23. = Preh 4pin B7, foot lift
- b24. = Preh 3pin, -900
- b25. = staf 4pin, knee-start
- b27. = Preh 3pin, needle thread monitor
- b28. = Connector
- b29. = Hirschmann, 5pin, cube, pedal

Omi Hed at 3/12

See control box
NO Sensewmat

5G53CV689X3

Pneumatics diagram # 95-748 360-95

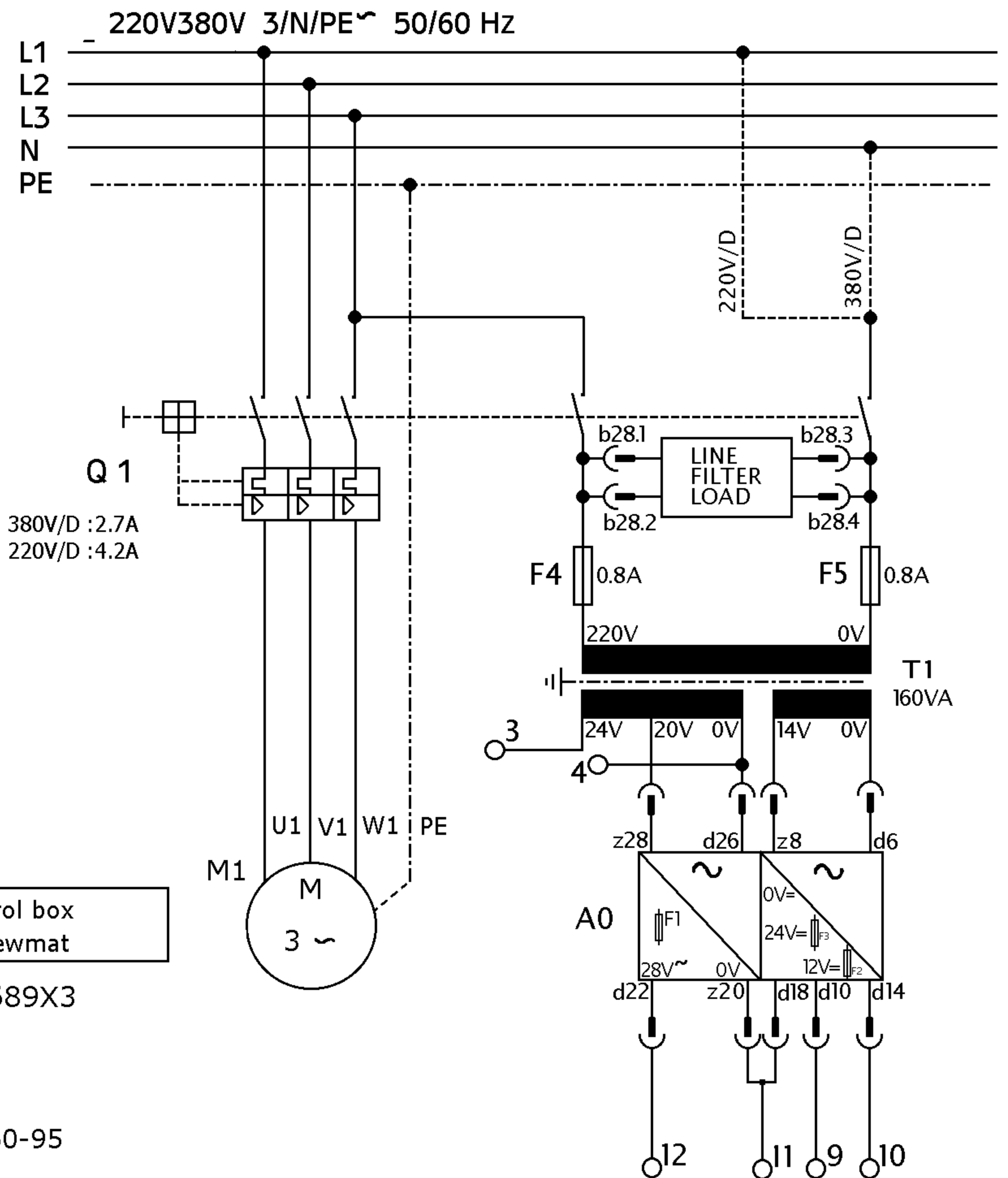

1 2 3 4 5 6 7 8 9 10 11 12 13 14 15 16

	19 94	Datum	Name	Typ	3557-3/22 ; 3/12
	Geschied	09.03.	Prinz	Ersatz für:	Zeichnung v. 28.08.92
	Gepr./Genehm.	09.03.	<i>lll</i> <i>lll</i>	Ersetzt durch:	
				Ausl. lt. Aend.-Nr.	
[Collar top-stitching (with pre-load)] engl.					Zeichnungs-Nr. 95-791 198-95/002
					Blattzahl: 13 Blatt: 2

PFAFF

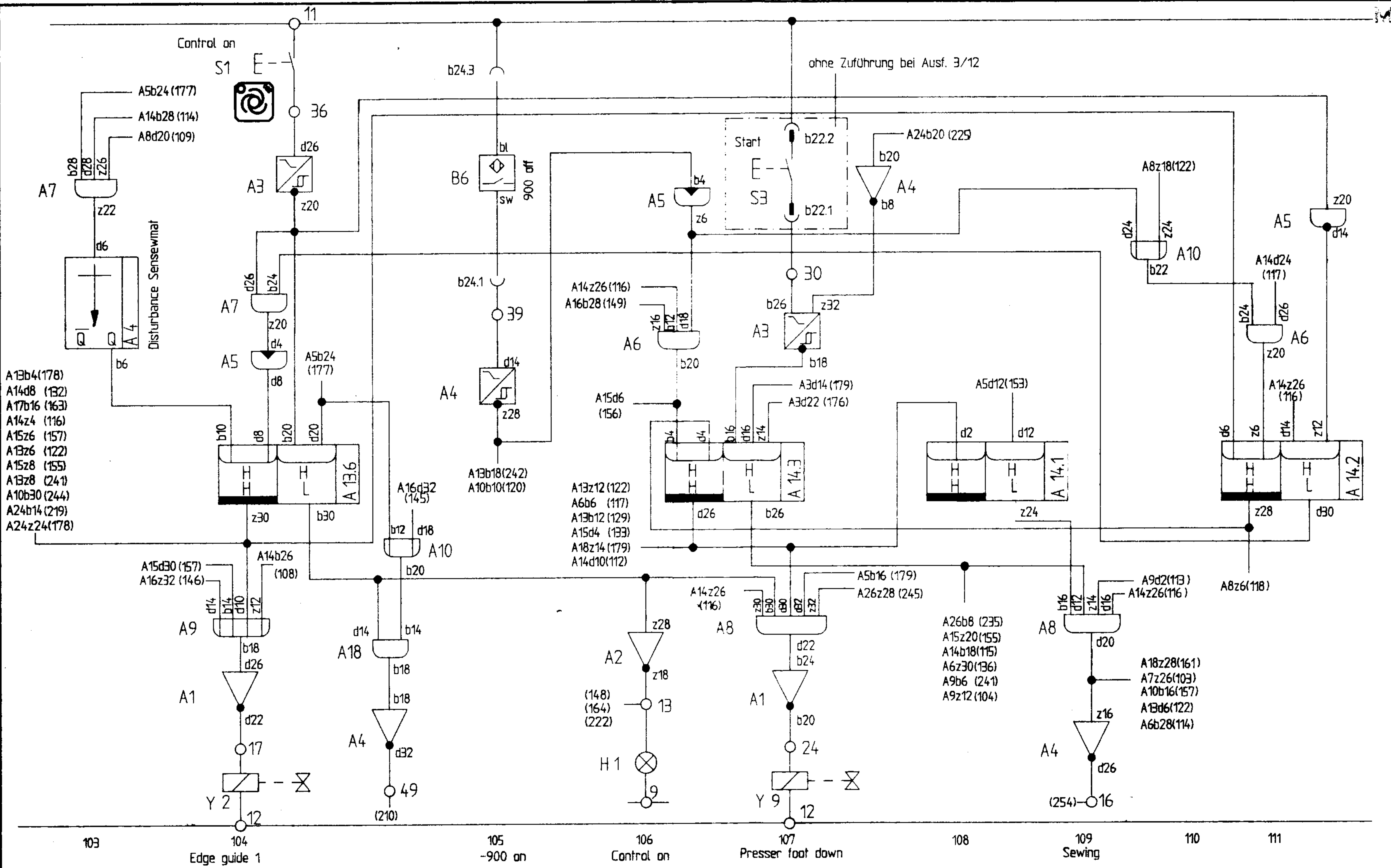

4					19 92	Datum	Name		Typ 3557-3/22; 3/12
3					Gezeichnet	28.08.	Strund	Ersetzt hier:	PFAFF Zeichnungs-Nr. 95-791 198-95/002 Blattzahl: 13 Blatt: 3
2					Gepr./Genehm.	5.05.93	ES	Ersetzt durch:	
+		1-36 129	20.0.93	Je	Normgepr.			Ausf. lt. Aend.-Nr.	
0	Geplaudert lt.	1-35 529	12.04.93	Je	Bemerkung	STP Kragenabsteppen (mit Zuführung) [Collar top-stitching (with pre-load)]		(deutsch) (engl.)	
Nr.	Art der Aenderung	Aenderung Nr.	Datum	Bezeichnet					
Für diese Zeichnung behalten wir uns alle Rechte vor Gem. DIN 34.					CAO				

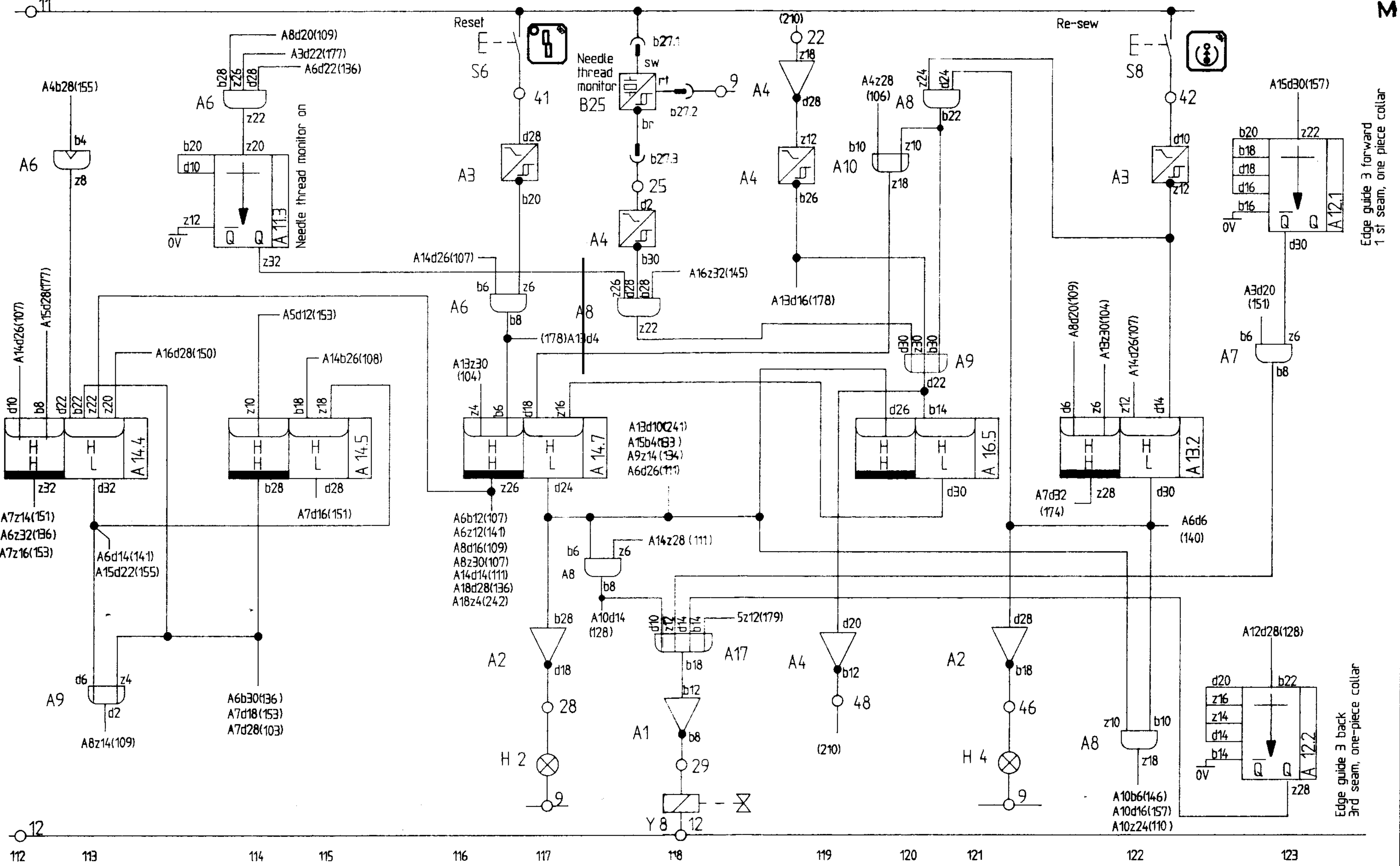

112 113 114 115 116 117 118 119 120 121 122 123

Control Edge guide 3 back Re-sew

Needle thread monitor

4				19 92	Datum	Name	Typ 3557-3/22 ; 3/12	
3				Geszeichnet	28.08.	<i>Strupp</i>	Ersatz für:	
2				Gepr./Genehm.	5.05.93	<i>ES</i>	Ersatz durch:	
1				Korrigiert			Ausl. d. Aend.-Nr.	
0	Erstellt lt.	1-36 129	20.10.93	Benennung STP Kragenabsteppen (mit Zuführung) (deutsch) [Collar top-stitching (with pre-load)] (engl.)			Zeichnungs-Nr. 95-791 198-95/002	
Nr.	Art der Änderung	Änderung Nr.	Datum					Blattzahl 13
Für diese Zeichnung behalten wir uns alle Rechte vor. Gem. DIN 34.				CAD				

M

Edge guide 3 forward
1 st seam, one piece collar

Edge guide 3 back
3rd seam, one-piece collar

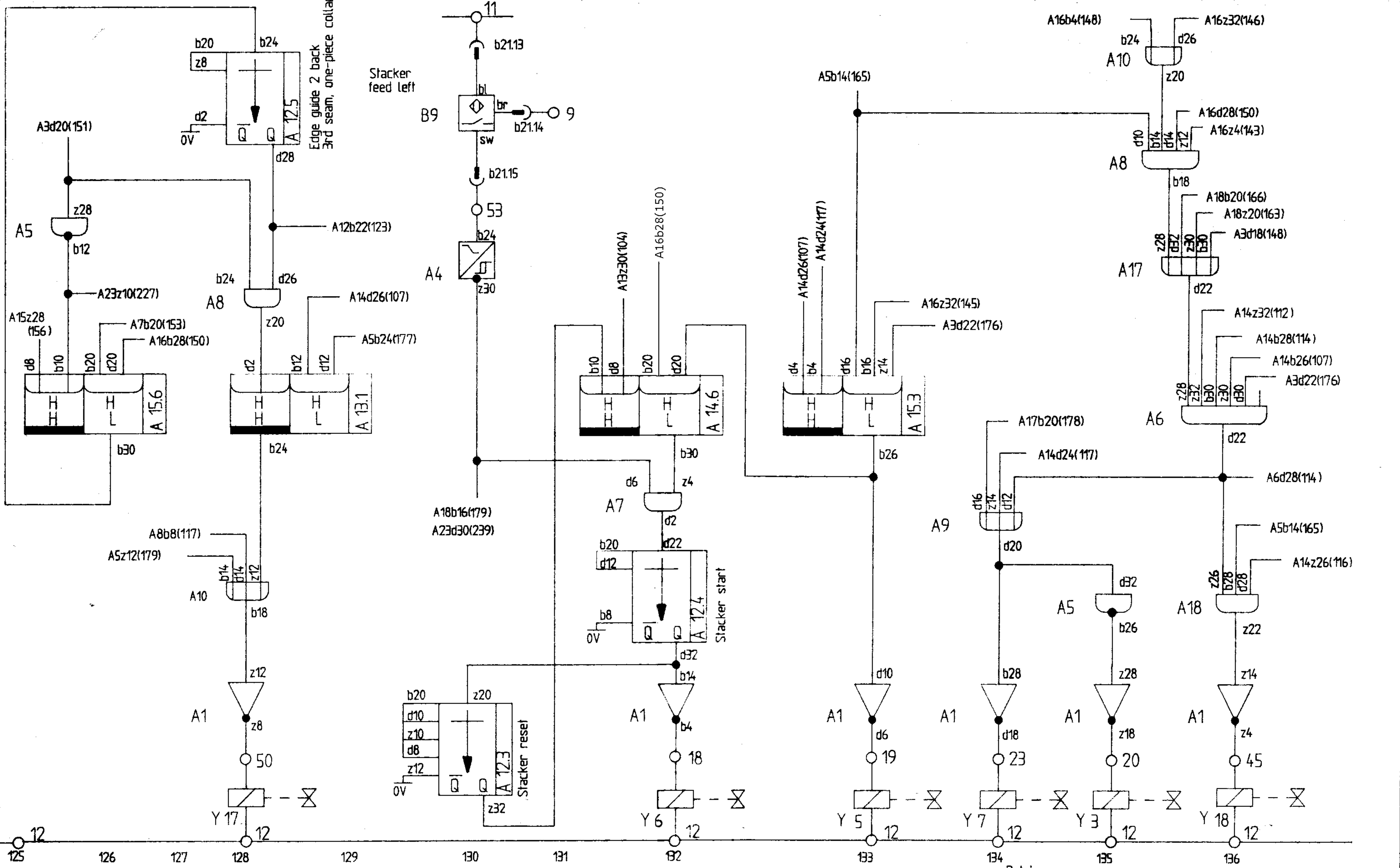

One-piece collar
3rd seam, edge guide 2

4					19 92	Datum	Name	Typ 3557-3/22 ; 3/12
3					Gezeichnet	28.08.	<i>Stimm</i>	Erz. Nr.:
2					Gepr./Genehm.	5.05.93	<i>BS</i>	Erz. durch:
1		1-36 129	20.09.93	<i>Jc</i>	Normgr.			Ausl. u. Anst.-Nr.
0	Einheitsl. u.	1-35 529	12.01.93	<i>Jc</i>	Bearbeitung			Zählungs-Nr.
Nr.	Art der Änderung	Änderung Nr.	Datum	Mark				95-791 198-95/002
Für diese Zeichnung behalten wir uns alle Rechte vor Gem. DIN 34.					CAO			Blattzahl: 13 Blatt: 5

STP Kragenabsteppen (mit Zuführung)
[Collar top-stitching (with pre-load)]

(deutsch)
(engl.)

PFAFF

Zählungs-Nr.
95-791 198-95/002

Blattzahl: 13 Blatt: 5

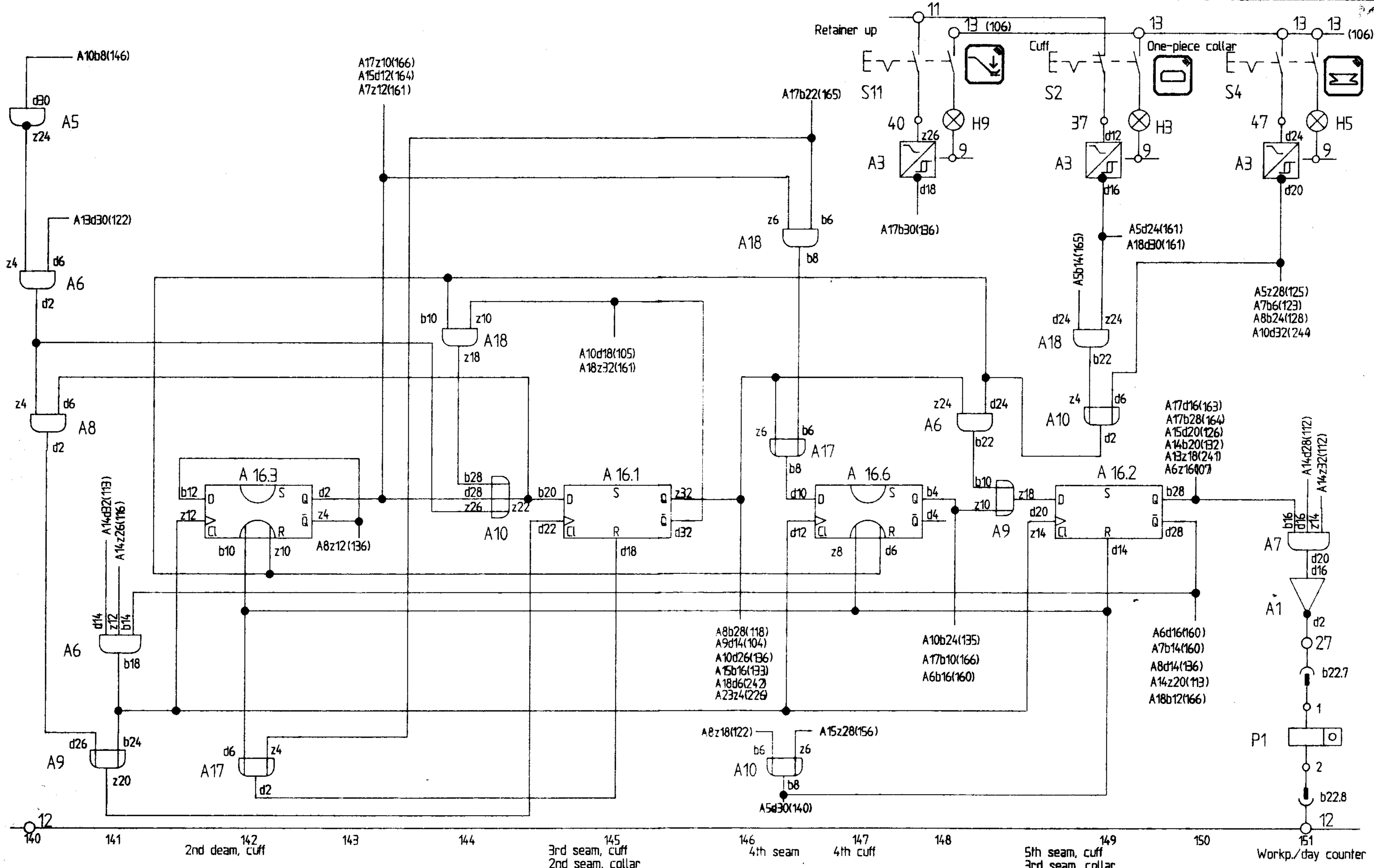

140 141 142 2nd deam, cuff 143 144 145 3rd seam, cuff 2nd seam, collar 146 4th seam 147 4th cuff 148 149 5th seam, cuff 3rd seam, collar 150 151 Workp./day counter

4					19 92	Datum	Name		Typ 3557-3/22 ; 3/12
3					Gezeichnet	28.08.	Schmitt	Ersatz Nr.	PFAFF
2					Gepr./Genehm.	5.05.93	ES	Ersatz durch	
1		1-36 129	20.10.93	JK	Montagepr.			Ausf. u. Aend.-Nr.	
0	Eingekauft II.	1-35 529	12.01.93	JK	Benennung	STP Kragenabsteppen (mit Zuführung) [Collar top-stitching (with pre-load)]		(deutsch) (engl.)	
Nr.	Art der Änderung	Änderung Nr.	Datum	Werk					Zeichnungs-Nr. 95-791 198-95/002
Für diese Zeichnung behalten wir uns alle Rechte vor Gem. DIN 341					CAD				Blattzahl 13 Blatt 6

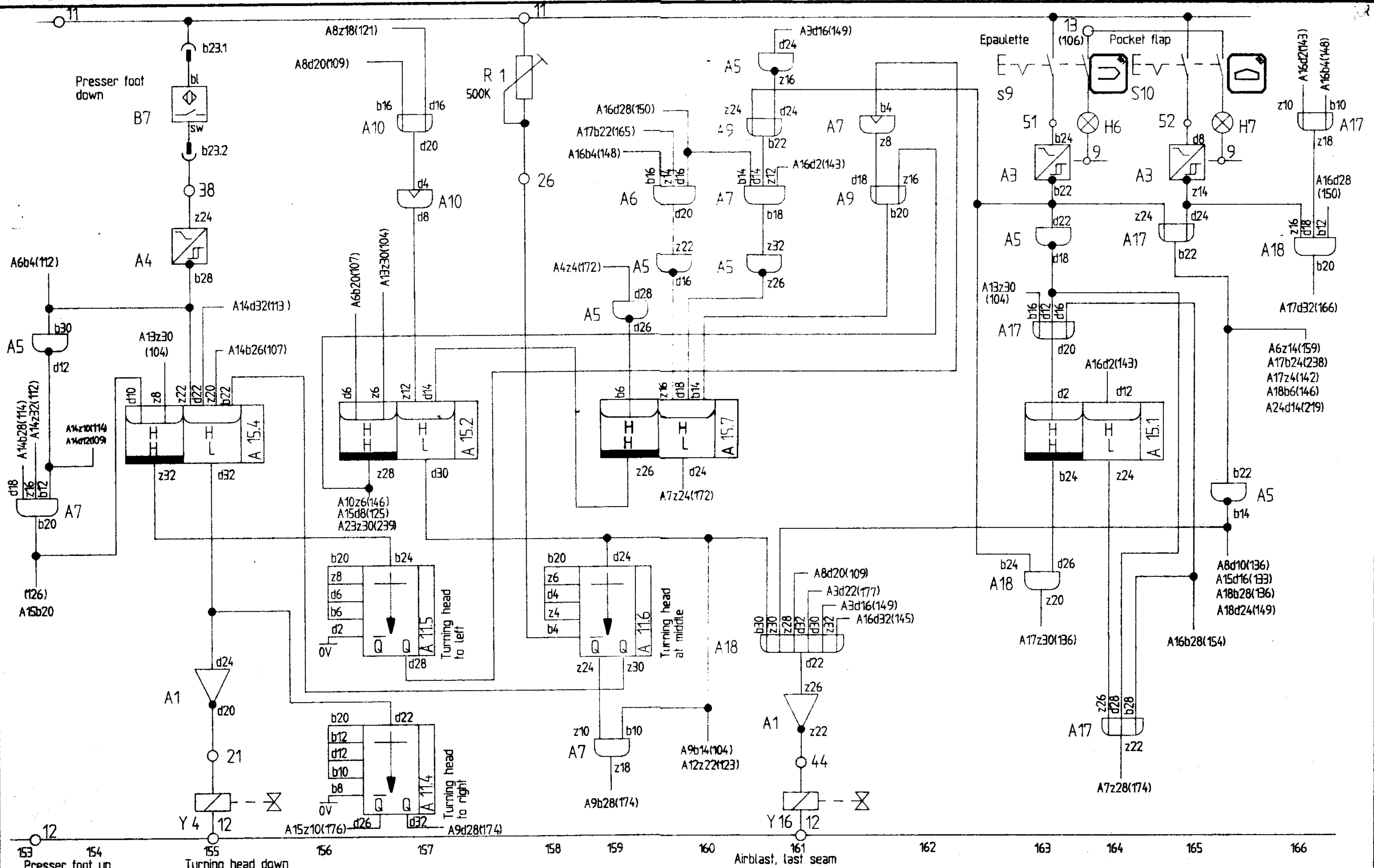

4					19 92	Datum	Name	Typ	3557-3/22 ; 3/12
3					Gezeichnet	28.08.	Schmitt	Erstellt von:	PFAFF Zeichnungs-Nr. 95-791 198-95/002 Blattzahl: 13 Blatt: 7
2					Gepr./Genehm.	5.05.93	B	Erstellt durch:	
1					Vorgepr.			Ausl. lt. Aend.-Nr.	
0	Ergebend lt.	1-36 129	20.0.93	Je	Bemerkung	STP Kragenabsteppen (mit Zuführung) (deutsch)			
Nr.	Art der Aenderung	Aenderung Nr.	Datum	Mark.	[Collar top-stitching (with pre-load)] (engl.)				
Für diese Zeichnung behalten wir uns alle Rechte vor. Gem. DIN 34.					CAD				

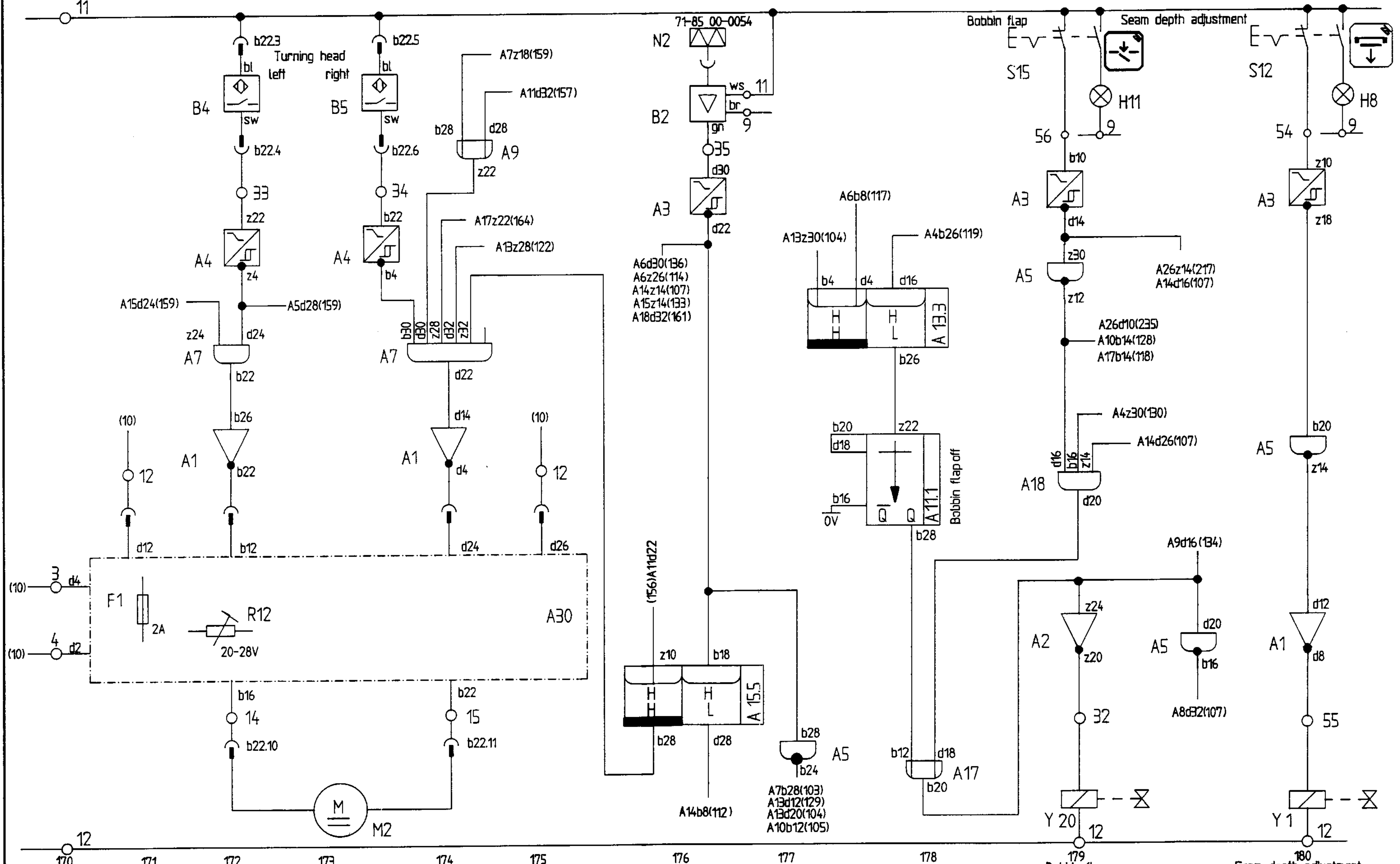

170	171	172	173	174	175	176	177	178	179	180
	to left	Turning head		to right					Bobbin flap	Seam depth adjustment
4							94	Datum	Name	Typ 3557-3/22 ; 3/12
3							Gezeichnet	9.03.	Spinn	Erstellt von: Zchn. v. 7.09.93
2							Gepr./Genehm.	10.03.	US US	Erstellt durch:
1							Montage:			Ausl. u. Aend.-Nr.
0	Englisch lt.						Benennung		engl.	Zeichnung-Nr.
Nr.	Art der Änderung	Änderung Nr.	Datum	Bearb.			[Collar top-stitching (with pre-load)]			95-791 198-95/002
Für diese Zeichnung behalten wir uns alle Rechte vor. Ein. 001 30.										Blattzahl: 13
										Blatt: 8

PFAFF

Zeichnung-Nr.
95-791 198-95/002
Blattzahl: 13 Blatt: 8

Control box, Efka 5G538V689X3, Pfaff part No. 71-59 00-0651

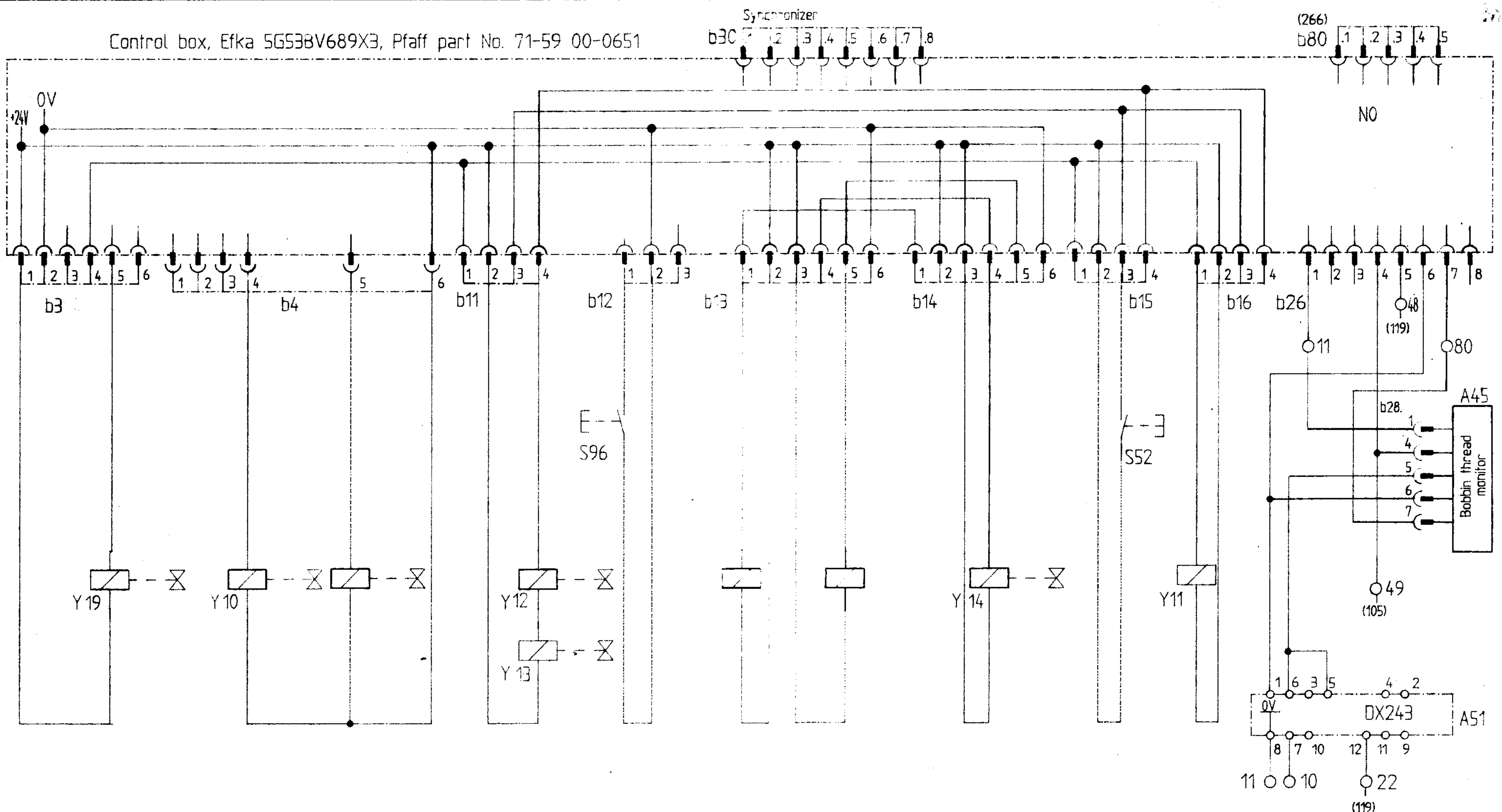

- 190 Presser foot lift
- 191
- 192 Edge guides 2 and 3 back
- 193
- 194
- 195 Feed drop, top feed
- 196
- 197
- 198 Single stitches at reduced stitch length
- 199
- 200 Thread trimmer
- 201 Thread wiper
- 202
- 203
- 204 Airblast, thread trimmer
- 205
- 206 Manual backtack
- 207
- 208 Backtack (feed regul.)
- 209
- 210 Bobbin thread disturbance
- 211

4					19 92	Datum	Name		Typ 3557-3/22 ; 3/12	
3					Gezeichnet	28.08.	<i>Spinn</i>	Erstellt von:	PFAFF	
2					Gepr./Genehm.	5.05.93	<i>R</i>	Erstellt durch:		
1		1-36 129	20.10.93	<i>Je</i>	Normgepr.			Ausf. d. Aend.-Nr.		
0	Eingekauft d.	1-35 529	12.01.93	<i>Je</i>	Benennung	STP Kragenabsteppen (mit Zuführung) (deutsch) [Collar top-stitching (with pre-load)] (engl.)			Zeichnungs-Nr. 95-791 198-95/002	
Nr.	Art der Aenderung	Aenderung Nr.	Datum	Zeich.						Blattzahl: 13
Für diese Zeichnung behalten wir uns alle Rechte vor Gem. DIN 34.					CAD					Blatt: 9

71-85 00-0111

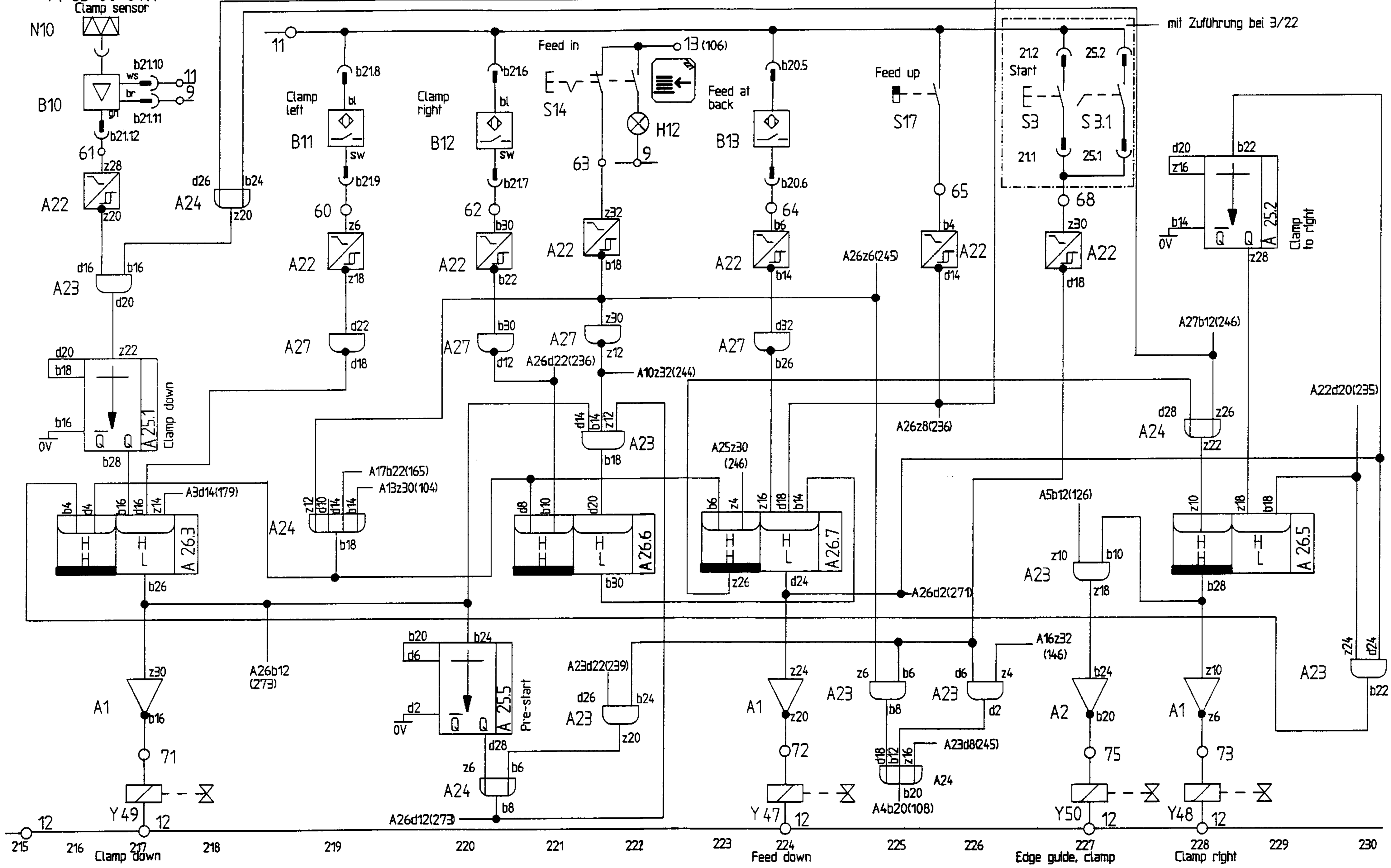

4					19 94	Datum	Name	Typ	3557-3/22 ; 3/12
3					Gezeichnet	9.03.	<i>S. Meyer</i>	Erstellt am:	28.08.92
2					Gepr./Genehm.	10.03.	<i>W. W.</i>	Erstellt durch:	
1					Managgr.			Auf. d. Anst.-Nr.	
0	Gezeichnet II.				Bearbeitung	STP Kragenabsteppen (mit Zuführung)		engl.	Zählung-Nr.
Nr.	Art der Änderung	Änderung Nr.	Stempel	Bezeichnung	[Collar top-stitching (with pre-load)]				95-791 198-95/002
Für diese Zeichnung bestehen wir uns alle Rechte vor Gem. DIN 341					CAD				Blattzahl: 13
									Blatt: 10

PFAFF

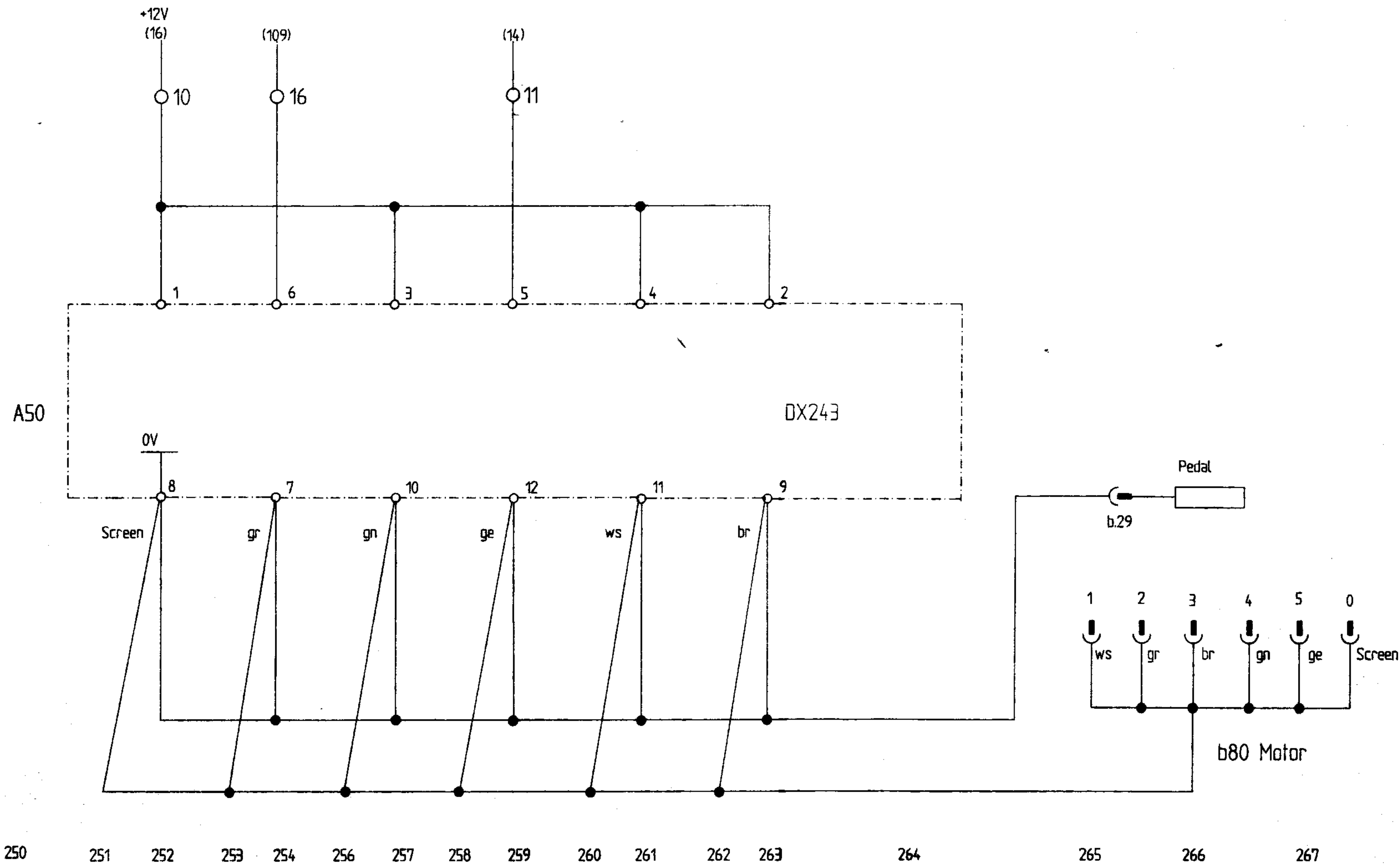

250 251 252 253 254 256 257 258 259 260 261 262 263 264 265 266 267

4					19 92	Datum	Name		Typ 3557-3/22: 3/12
3					Gezeichnet	28.08.	Stump	Erstellt von:	PFAFF
2					Gepr./Geprüft	5.05.93	B	Erstellt durch:	
+		1-36 129	20.10.93	Je	Montagepr.			Ausf. u. Aend.-Nr.	
0	Ergebeblatt Nr.	1-35 529	12.01.93	Je	Benennung	STP Kragenabsteppen (mit Zuführung) [Collar top-stitching (with pre-load)]		(deutsch) (engl.)	
Nr.	Art der Änderung	Änderung Nr.	Datum	Blatt					Zählung-Nr. 95-791 198-95/002
Für diese Zeichnung behalten wir uns alle Rechte vor Gem. DIN 34.				CAD					Blattzahl: 13 Blatt: 12

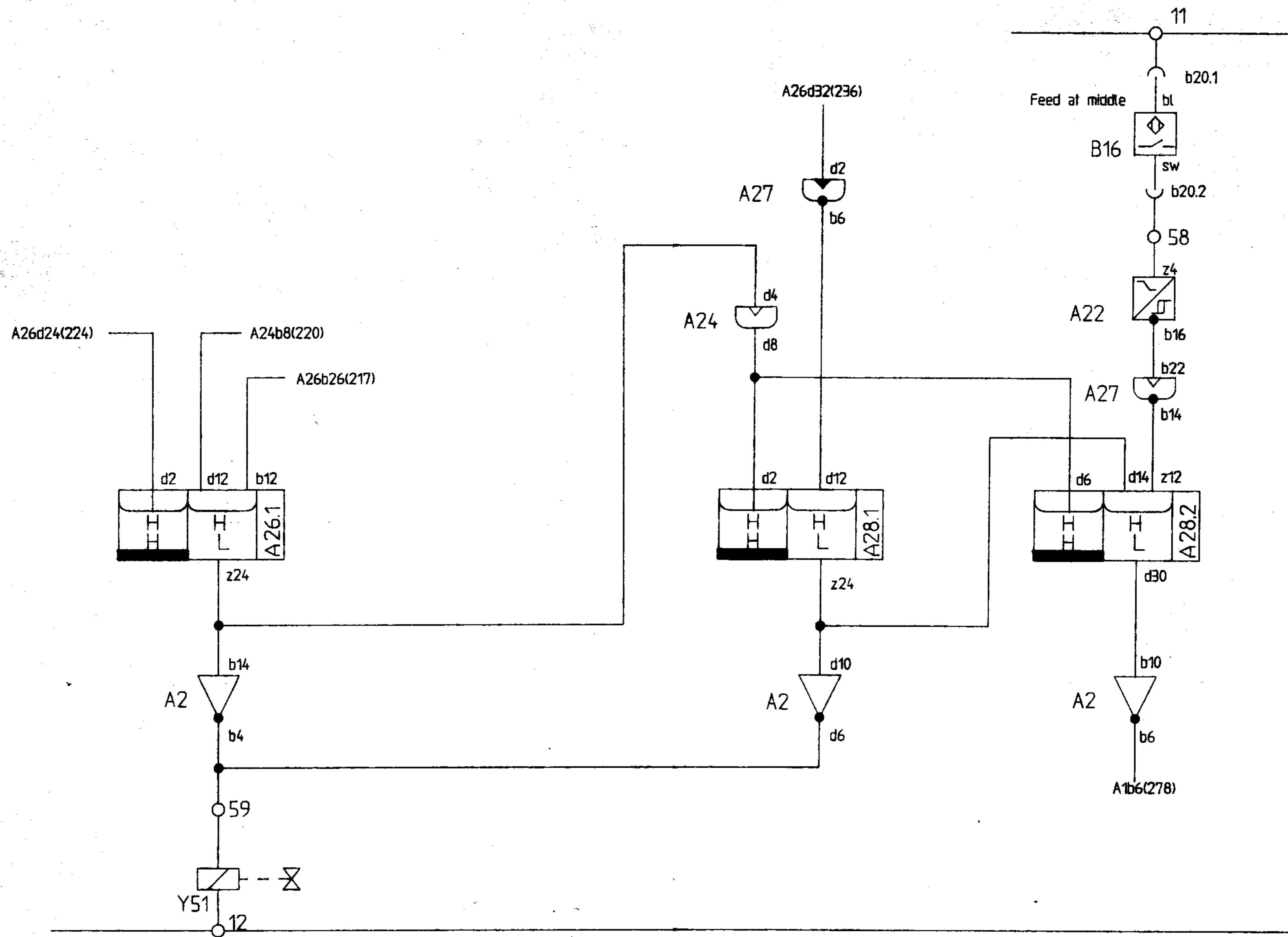

270 271 272 273 274 275 276 277 278 278 279 280 281

Feed back Backward feed stops

4					19 92	Datum	Name		Typ 3557-3/22 ; 3/12
3					Gezeichnet	28.08.	Schump		Ersatz für:
2					Gepr./Genehm.	5.05.93	B		Ersetzt durch:
1					Normgepr.				Aust. lt. Änd.-Nr.
0	Eingeführt lt.	1-36 129	20.10.93	J	Benennung	STP Kragenabsteppen (mit Zuführung) (deutsch)			Zeichnungs-Nr. 95-791 198-95/002
Nr.	Art der Änderung	Änderung Nr.	Datum	Bearb.		[Collar top-stitching (with pre-load)] (engl.)			
Für diese Zeichnung behalten wir uns alle Rechte vor (Gen. Dkt 34)					CAD				Blattzahl: 13 Blatt: 13

PFAFF

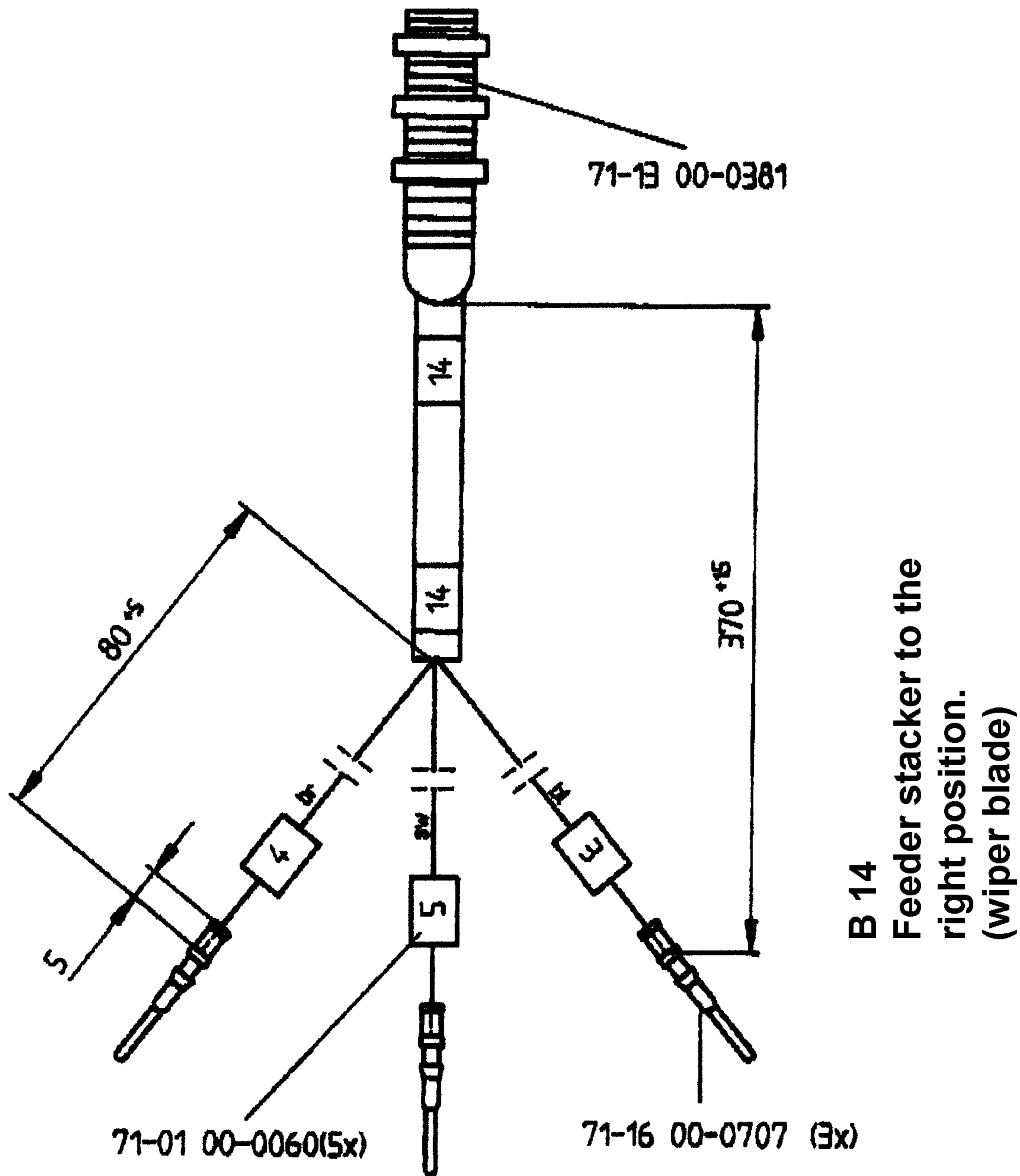

		4						
		3						
		2						
		1						
		0	Erzgl. lt.				Farbkombination	9
Paßmaß	Abmaße	Nr.	Zust. korrekt vgr.	Änderung Nr.	Datum	Bearb.	Oberflächenzustand	Schütz-zahl x
Allgemeintoleranzen: +10%							Typ: 3557-3/22	
19 91	Datum	Name	Oberflächen	Werkstoff:		PFAFF		
Gezeichnet	25.09	Schub	DN ISO 1802					
Geprüft			Werkstückkanten:	Hergestellt aus				
Fkt. gepr.								
Normgepr.			 DN 6784	Ersatz für:		Ersatz durch:		
Genehmigt	14.09.92	AK		Benennung:		Ausf. lt. Änd.-Nr.		
Maßstab			Näherungsinitiator			Zeichnungs-Nr.		
1:1						95-783 944-X1		
Schutzvermerke nach DIN 34 beachten. Copyright reserved.						CAO	Blattzahl	Blatt

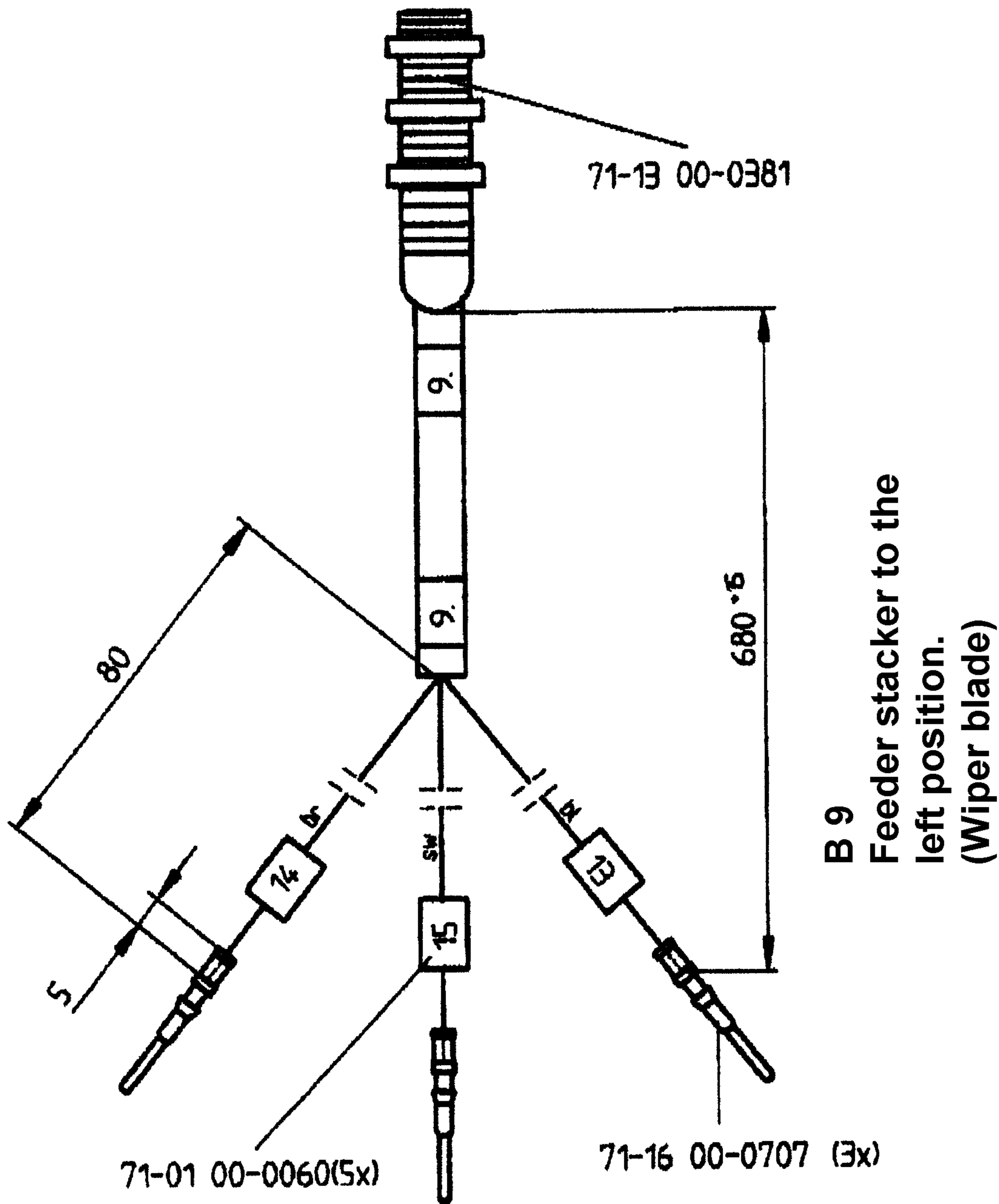

ähnlich

		4						
		3						
		2						
		1						
		0	Eingel. U.				Farbkombination	9
Paßmaß	Abmaße	Nr.	Zahl kommt vor	Änderung Nr.	Datum	Bearb.	Oberflächenzustand	Sch.-Zahl x
Allgemeintoleranzen: +10%						Typ: 3557-3/22		
19 92	Datum	Name	Oberflächen	Werkstoff:		PFAFF		
Gezeichnet	6.04.	S. K. M.	DIN ISO 1302					
Geprüft			Werkstückkanten:	Hergestellt aus:		Ersatz für:		
Fkt. gepr.						Ersetzt durch:		
Normgepr.						Ausf. U. Änd.-Nr.		
Genehmigt	08.09.	R.	DIN 6784			Zeichnungs-Nr.		
Maßstab	Benennung:					95-783 940-X1		
1:1			Näherungsinitiator			Blattzahl: Blatt:		
Schutzvermerke nach DIN 34 beachten. Copyright reserved.						CAD		

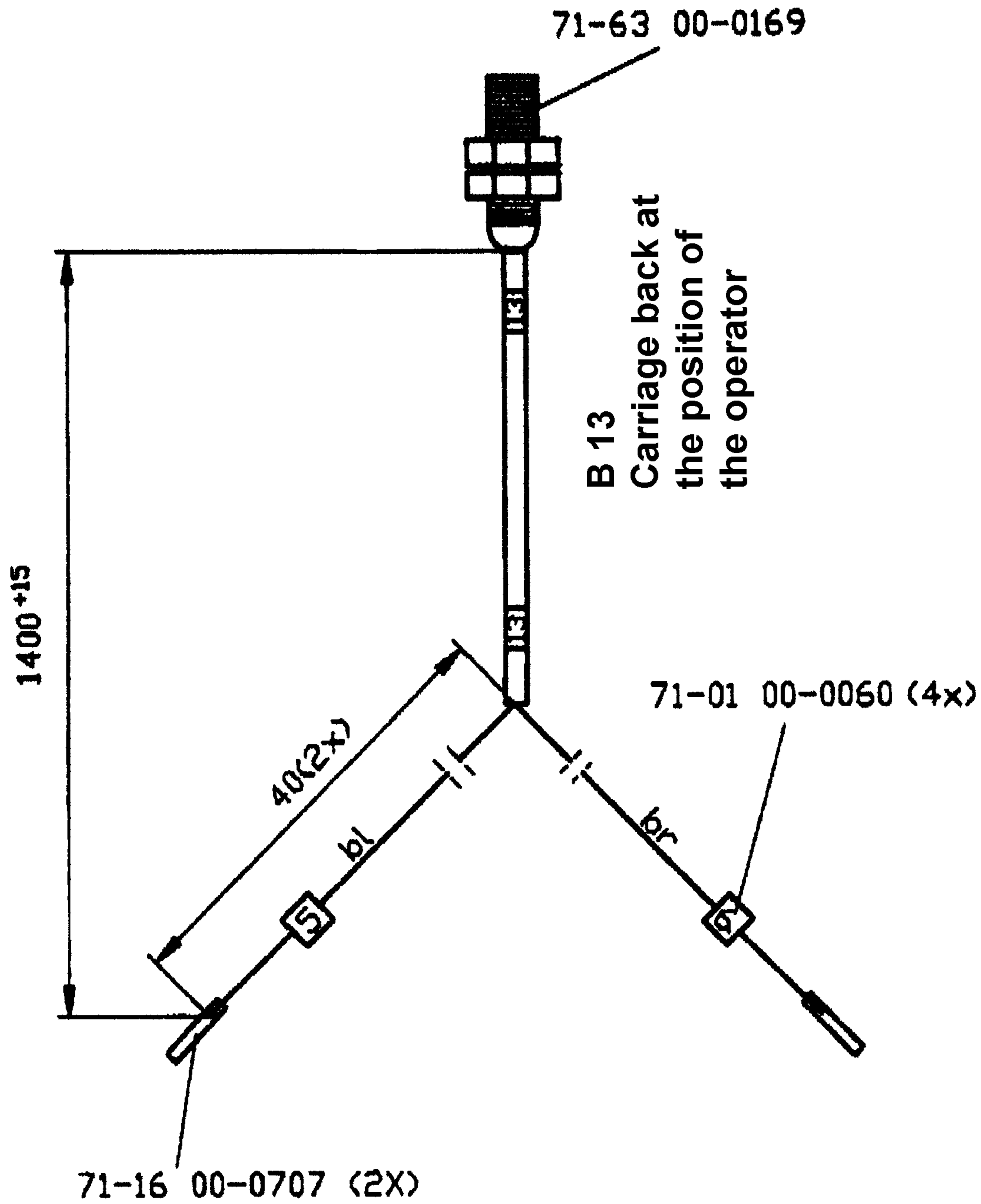

		4								
		3								
		0	Eingef. It.				Farbkombination	9		
Passmass	Abmasse	Nr.	Zahl kommt vor	Änderung Nr.	Datum	Bearb.	Oberflächenzustand	Schl-zahl x		
Allgemeintoleranzen			+10%	Tolerierung DIN ISO 8015			Typ 3557-3/22			
19 92	Datum	Name	Oberflächen	Verkstoff:		PFAFF				
Gezeichnet	2.04	Schmitt	DIN ISO 1302							
Geprüft			Verkstueckdaten:	Hergestellt aus					Ersetz fuer	
Fkt. gepr.									Ersetzt durch	
Normgepr.						Ausf. lt. Änd-Nr.				
Genehmigt	08.09.	PK	DIN 6784				Zeichnungs-Nr.			
Maßstab	1:1	Benennung			95-784 052-X1					
Schutzvermerke nach DIN 34 beachten				Copyright reserved	CAD	Blattzahl	1	Blatt		

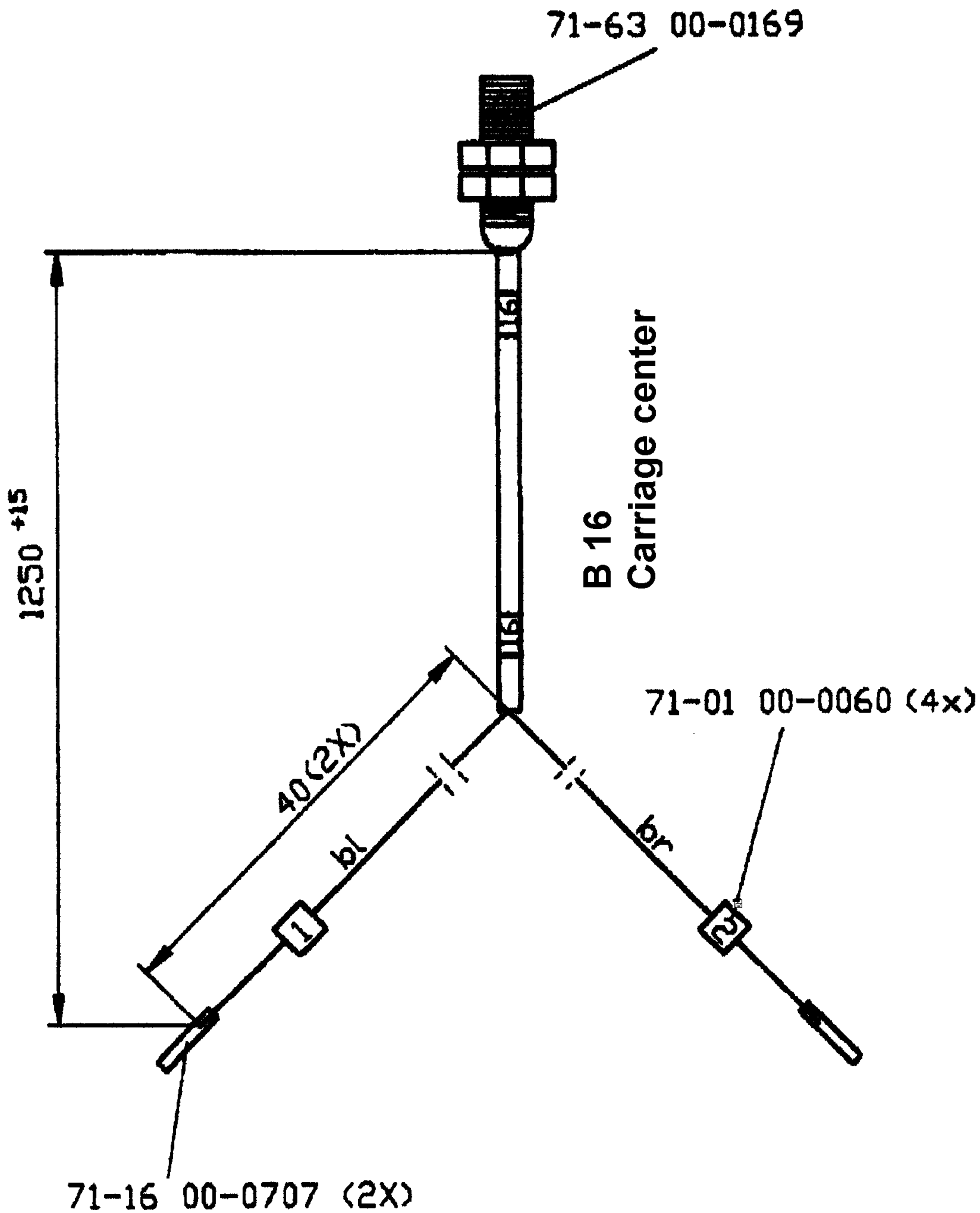

		4						
		3						
		2						
		1						
		0	Engf. lt.				Farbkombination	9
Passmass	Abmasse	Nr.	Zahl kann vor	Aenderung Nr.	Datum	Bearb.	Oberflaechenzustand	Schl- zahl x
Allgemeintoleranzen		+10%		Tolerierung DIN ISO 8015		Typ: 3557-3/22		
19 92	Datum	Name	Oberflaechen DIN ISO 1302	Verkstoff:		PFAFF		
Gezeichnet	2.04	Stinn	Verkstueckkanten:	Hergestellt aus				
Geprueft			 DIN 6784	Ersatz fuer		Ersetzt durch		
Fkt. gepr.					Ausf. lt. Aend.-Nr.			
Normgepr.				Benennung:		Zeichnungs-Nr.		
Genehmigt	01.08.	RK.		Naeherungsinitiator		95-784 049-X1		
Maassstab	1:1	 Schutzvermerke nach DIN 34 beachten.		Copyright reserved. CAD		Blattzahl 1		Blatt 1

aerhaelich

71-63 00-0169

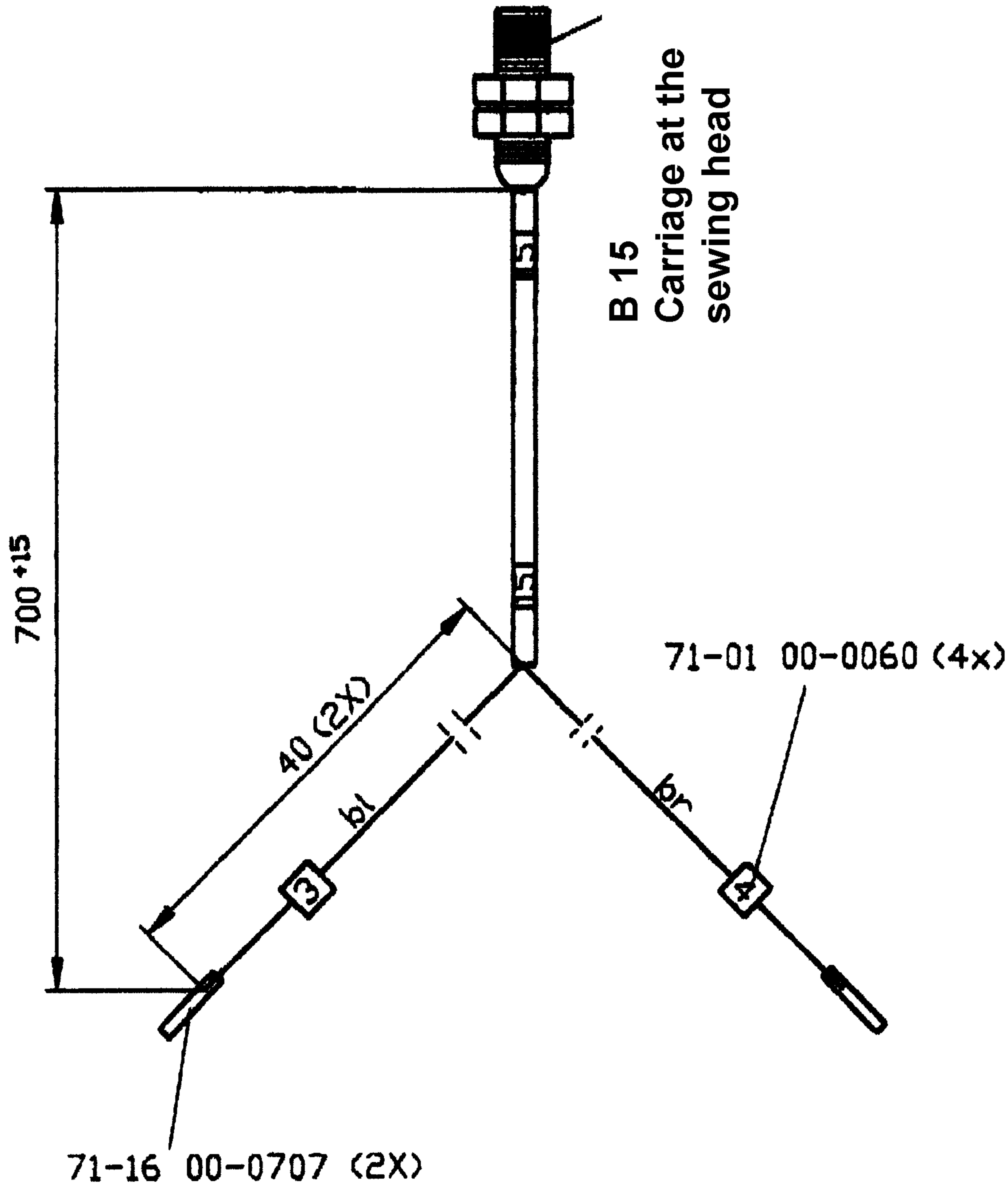

			4							
			3							
			2							
			1							
			0	Engel. lt.				Farbkombination	9	
Passnass	Abnasse	Nr.	Zahl kommt vor	Änderung Nr.	Datum	Bearb.	Oberflächenzustand	Schl.-zahl x		
Allgemeintoleranzen			+10%		Tolerierung DIN ISO 8015		Typ: 3557-3/22			
19 92	Datum	Name	Oberflächen		Verkstoff:		PFAFF			
Gezeichnet	2.04	Stvna	DIN ISO 1302							
Geprüft			Verkstueckkonten:		Hergestellt aus		Ersetzt fuer			
Fkt. gepr.			DIN 6784				Ersetzt durch			
Normgepr.							Ausf. lt. Änd-Nr.			
Genehmigt	08.08	AK					Zeichnungs-Nr.			
Massstab	1:1	Benennung		Naeherungsinitiator		95-784 053-X1				
Schutzvermerke nach DIN 34 beachten. Copyright reserved. CAD					Blattzahl		1		Blatt	1

PFAFF

PFAFF
Postfach 3020
D-67653 Kaiserslautern

Telefon: (0631) 200-0
Telefax: (0631) 17202
Telex: 45753

Gedruckt in der BRD
Printed in Germany
Imprimé en R.F.A.
Impreso en la R.F.A.
Stampato in R.F.G.
отпечатано ФРГ