

PFAFF

3586-2/02

Instruction Manual

This instruction manual applies to machines from the following serial numbers onwards:

2721352 →

The reprinting, copying or translation of PFAFF Instruction Manuals, whether in whole or in part, is only permitted with our previous permission and with written reference to the source.

PFAFF Industrie Maschinen AG

Postfach 3020

D-67653 Kaiserslautern

Königstr. 154

D-67655 Kaiserslautern

Contents	Chapter
Register 01	
Safety	1
Register 02	
Proper use	2
Specifications	3
Disposal of the machine	4
Transport, packaging and storage	5
Explanation of the symbols	6
Register 03	
Controls	7
Register 04	
Mounting and commissioning the machine	8
Register 05	
Preparation	9
Register 06	
Sewing	10
Input mode functions	11
Register 07	
Care and maintenance	12
Adjustment	13
Register 08	
Controller	14
Circuit diagrams	15
Register 09	
Parts list	
Register 10	
Miscellaneous	

	Contents	Chapter - Page
1	Safety	1 - 1
1.01	Directives	1 - 1
1.02	General notes on safety	1 - 1
1.03	Safety symbols	1 - 2
1.04	Important points for the user	1 - 2
1.05	Operating and specialist personnel	1 - 3
1.05.01	Operating personnel	1 - 3
1.05.02	Specialist personnel	1 - 3
1.06	Danger	1 - 4

1 Safety

1.01 Directives

This machine was built in accordance with the European regulations stated in the Conformity and Manufacturer's Declaration.

In addition to this Instruction Manual, also observe all generally accepted, statutory and other regulations and legal requirements - also those of the country in which the machine will be operated - and all valid environmental protection regulations!

Applicable local regulations of the social insurance society for occupational accidents or other supervisory organizations are to be strictly adhered to!

1.02 General notes on safety

- This machine must only be operated by adequately trained operators and only after having completely read and understood the Instruction Manual!
- All Notes on Safety and Instruction Manuals of the motor manufacturer are to be read before operating the machine!
- The danger and safety notices fixed on the machine must be observed and must remain attached.
- Do not remove attached safety devices or set them out of action
- This machine must only be used for the purpose for which it is intended and must not be operated without its safety devices. All applicable safety regulations must be observed.
- When replacing sewing tools (such as e.g. needles, sewing foot etc.), when threading the machine, leaving the workplace and during maintenance work, the machine must be disconnected by operating the on/off switch, or by removing the mains plug!
- Daily maintenance work must only be carried out by appropriately trained personnel!
- For maintenance and repair work on pneumatic equipment, the machine must be disconnected from the pneumatic supply system! Exceptions are adjustment work and function tests which are carried out by appropriately trained staff.
- Repair work and special maintenance work must only be carried out by specialists or appropriately trained personnel!
- Work on electrical equipment must only be carried out by appropriately trained specialist personnel!
- Work is not permitted on parts and equipment which are connected to the power supply! Exceptions to this are contained in the regulations EN 50110.
- Modifications and alterations to the machine must only be carried out pursuant to all relevant safety regulations!
- Only spare parts which have been approved by us are to be used for repairs! We expressly point out that any replacement parts or accessories not supplied by us have not been tested and approved by us. The installation and/or use of any such products may result in negative changes to the constructional characteristics of the machine. We are not liable for any damage which may be caused by non-original parts.

1.03 Safety symbols



Danger!
Points to be observed!



Danger of injury to operating and specialist personnel!



Caution

Do not operate without finger guard and safety devices. Before threading, changing bobbin and needle, cleaning etc. switch off main switch.

1.04 Important points for the user

- This Instruction Manual is a component part of the machine and must be available to the operating personnel at all times.
The Instruction Manual must be read before operating the machine for the first time.
- The operating and specialist personnel is to be instructed on the safety equipment of the machine and regarding safe work methods.
- It is the duty of the user to only operate the machine in perfect running order.
- It is the obligation of the user to ensure that none of the safety mechanisms are removed or deactivated.
- It is the obligation of the user to ensure that only authorized persons operate and work on the machine.

Further information can be obtained at the point of sale.

1.05 Operating and specialist personnel

1.05.01 Operating personnel

Operating personnel are persons responsible for the preparation, operating and cleaning of the machine as well as taking care of problems arising in the sewing area.

The operating personnel is obliged to observe the following points and must:

- always observe the Notes on Safety in the Instruction Manual!
- never use any working methods which could reduce the level of safety in using the machine!
- not wear loosely fitting clothing or jewelery such as chains or rings!
- also ensure that only authorized persons have access to the potentially dangerous area around the machine!
- always immediately report to the user any changes in the machine which may reduce its level of safety!

1.05.02 Specialist personnel

Specialist personnel are persons who have completed expert education/training in the fields of electrics, electronics and mechanics. They are responsible for the lubrication, maintenance, repair and adjustment of the machine.

The specialist personnel is obliged to observe the following points and must:

- always observe the Notes on Safety in the Instruction Manual!
- switch off the On/Off switch before carrying out adjustments or repairs and ensure that it cannot be switched on again unintentionally!
- never work on parts and devices which are still connected to the power supply! The only exceptions to this directive are found in the regulations EN 50110.
- replace the protective coverings and close the electrical control box after all repairs or maintenance work!

1.06

Danger



A working area of 1 meter is to be kept free both in front of and behind the machine while it is in operation, so that it is always easily accessible.



Never reach into the sewing area while sewing!
Danger of injury by the needle!



Never leave objects on the table while adjusting the machine settings! Objects can become trapped or be slung away!
Danger of injury by hurled objects!

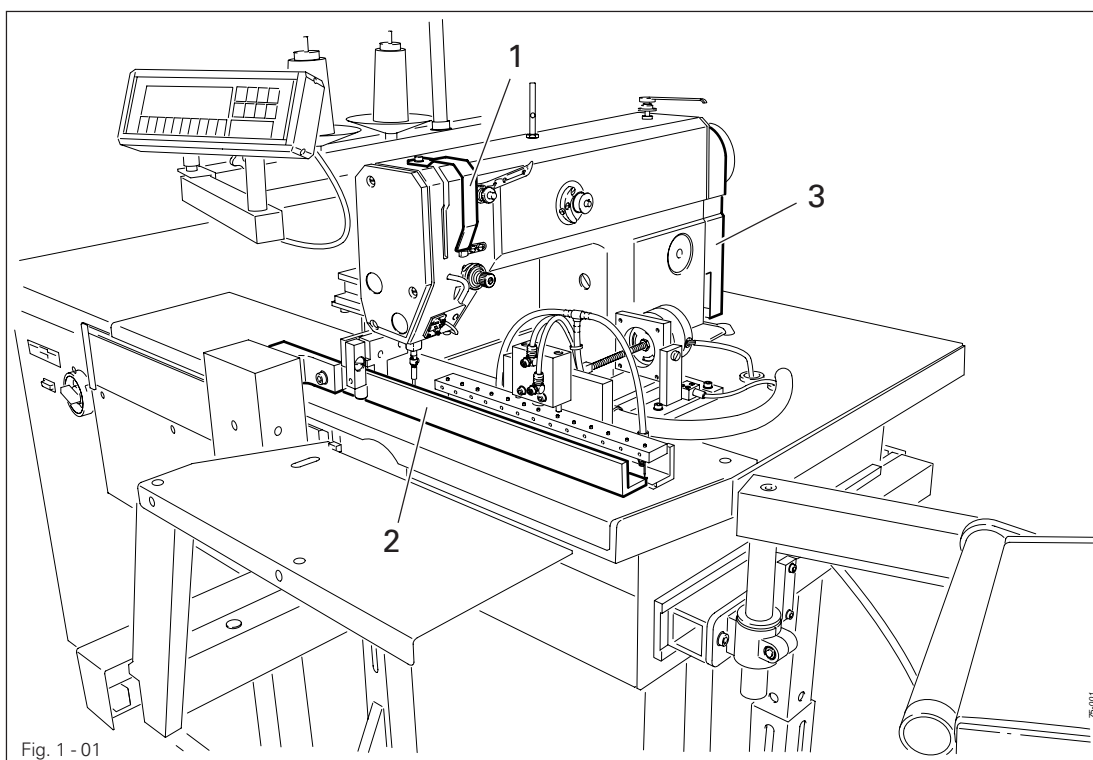

Do not operate the machine without its take-up lever guard 1!
Danger of injury due to the motion of the take-up lever!



Do not place fingers under the pressure bar 2!
Danger of crushing by the descending pressure bar 2!



Do not operate the machine without machine cover 3!
Danger of injury from moving parts!

	Contents	Chapter - Page
2	Proper use	2 - 1
3	Specifications	3 - 1
4	Disposal of the machine	4 - 1
5	Transport, packaging and storage	5 - 1
5.01	Transport to the customer's premises	5 - 1
5.02	Transport within the customer's premises	5 - 1
5.03	Disposal of the packaging	5 - 1
5.04	Storage	5 - 1
6	Explanation of the symbols	6 - 1

2

Proper use

The PFAFF 3586-2/02 is a mechanised sewing unit for sewing darts and pleats with or without basting stitch.



Any and all uses of this machine which have not been approved of by the manufacturer are considered to be inappropriate! The manufacturer cannot be held liable for any damage caused by the inappropriate use of the machine! The appropriate use of the machine includes the observance of all operational, adjustment, maintenance and repair measures required by the manufacturer!

3 Specifications ▲

Stitch type:	301
Max. sewing speed:	4500 s.p.m.
Stitch length:	1.0 - 3.0 mm
Basting stitch length	6.0 - 9.0 mm
(This value is calculated automatically and cannot be set)	
Needle system:	134 KK
Needle size (Nm) in 1/100 mm:	80 - 100
Dart length:	9 - 250 mm
Dart depth:	
Up to a dart length of 80 mm	30 mm
From a dart length over 80 mm	37 mm
Pleat length:	9 - 250 mm
Pleat depth:	3 - 70 mm
Working height:	760 - 1140 mm
Motor speed:	200 - 4500 r.p.m.
Power requirement:	approx. 1200 VA
Connection voltage:	230 V, 50 -60 Hz
Min. working pressure:	6 bar
Noise data:	
Emission sound level at the workplace at a speed of 4500 spm:	81 dB(A)■
(Noise measurement in acc. with DIN 45 635-48-A-1, ISO 11204, ISO 3744, ISO 4871)	
Machine dimensions:	
Length:	1250 mm
Width:	850 mm
Height (without reel stand):	1040 - 1420 mm
Weight:	135 kg

▲ Subject to alteration

■ $K_{pA} = 2,5$ dB

4 Disposal of machine

- The proper disposal of the machine is the responsibility of the customer.
- The materials used in the machines are steel, aluminium, brass and various plastics. The electrical equipment consists of plastics and copper.
- The machine is to be disposed of in accordance with the locally valid environmental protection regulations. If necessary, a specialist is to be commissioned.



Special care is to be taken that parts soiled with lubricants are separately disposed of in accordance with the locally valid pollution control regulations!

5 Transportation, packing and storage

5.01 Transportation to customer's premises

All machines are delivered completely packed.

5.02 Transportation inside the customer's premises

The manufacturer cannot be made liable for transportation inside the customer's premises nor to other operating locations. It must be ensured that the machines are only transported in an upright position.

5.03 Disposal of packing materials

The packing materials of this machine comprise paper, cardboard and VCE fibre. Proper disposal of the packing material is the responsibility of the customer.

5.04 Storage

If the machine is not in use, it can be stored as it is for a period of up to six months, but it should be protected against dust and moisture.

If the machine is stored for longer periods, the individual parts, especially the surfaces of moving parts, must be protected against corrosion, e.g. by a film of oil.

Explanation of the symbols

6 Explanation of the symbols

In this Instruction Manual, tasks to be carried out and important information are drawn to your attention by symbols. The symbols have the following meanings:



Note, information



Cleaning, care



Lubrication

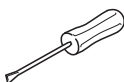

Servicing, repairing, adjustment, maintenance
(only to be carried out by specialist personnel)

	Contents	Chapter - Page
7	Control elements	7 - 1
7.01	On/off switch	7 - 1
7.02	Disk drive	7 - 1
7.03	Graphics control panel	7 - 2
7.03.01	Display	7 - 2
7.03.02	Operational mode keys	7 - 3
7.03.03	Function keys	7 - 3
7.03.04	Number keys	7 - 3
7.04	Bundle clamp switch (optional)	7 - 4

7 Control elements

7.01 On/off switch

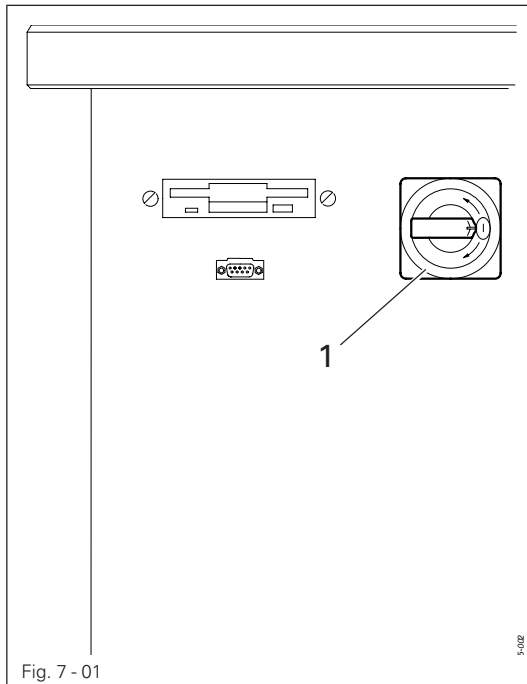

- By turning switch 1 the machine's power supply is switched on or off.

7.02 Disk drive

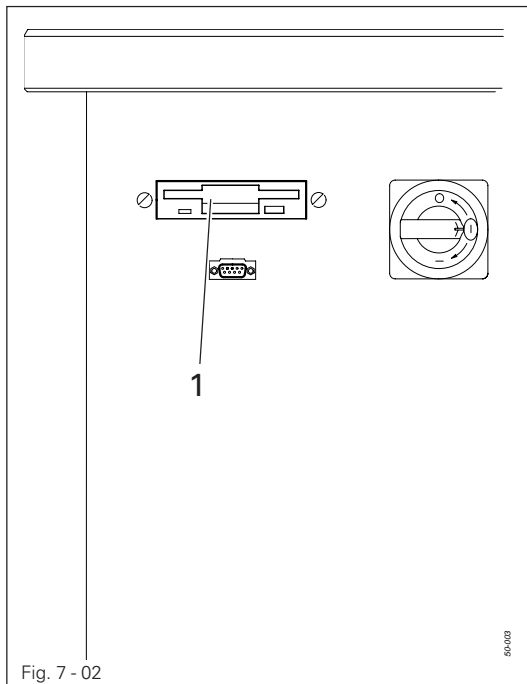

- Disk drive 1 can be used to read in sewing programs and operating software.

7.03 Graphics control panel

The graphics control panel **1** consists of the display screen and 2 key zones.

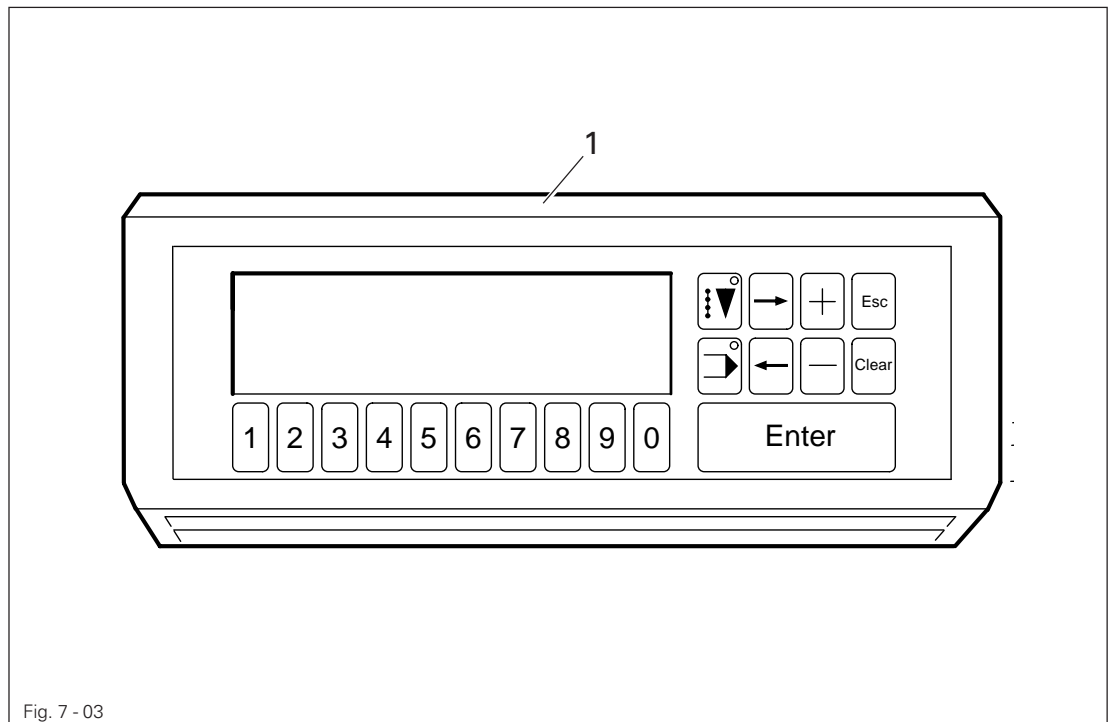

Fig. 7 - 03

7.03.01 Display

In its basic condition the displays on the screen are divided into 3 part sections:

Status bar

The status bar is in the upper section of the display. Here, up to 5 pictograms with their corresponding values can be displayed (see **Chapter 10.01 Status bar**).

Text field

The text field is in the middle section of the screen. Here, messages can be displayed in 2 lines.

Pictogram bar

The pictogram bar is found at the bottom of the display. The functions of the symbols, which appear here, can be called up using the **number keys**. Active functions are shown by a symbol displayed on a dark background.



When creating or modifying seam programs, the different seam types are shown graphically on the display.

Control elements

7.03.02 Operational mode keys

By pressing the corresponding key, two different modes of operation can be selected.
The selected mode of operation is indicated by a diode.



SEWING mode



INPUT mode

7.03.03 Function keys

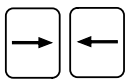

Arrow keys (right/left)

- To move to another menu page
- To position the cursor when entering several values in one line
- To select the next program within a sequence program

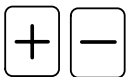

Plus/Minus keys

- To select sign for input values
- To raise and lower input values



Esc-key

- Interruption of inputs without taking over the input value
- Return to superordinate menu functions



Clear key

- To reset the input value to 0



Enter key

- To confirm an input value
- To acknowledge an error after an error message

7.03.04 Number keys



Below the display there is a row of number keys (1-0).

Depending on the operating mode, these keys have the following functions:

- Executing a function illustrated by the symbol of the corresponding key
- Entering of numerical values
- Selecting functions or menu levels

7.04 Bundle clamp switch (optional)

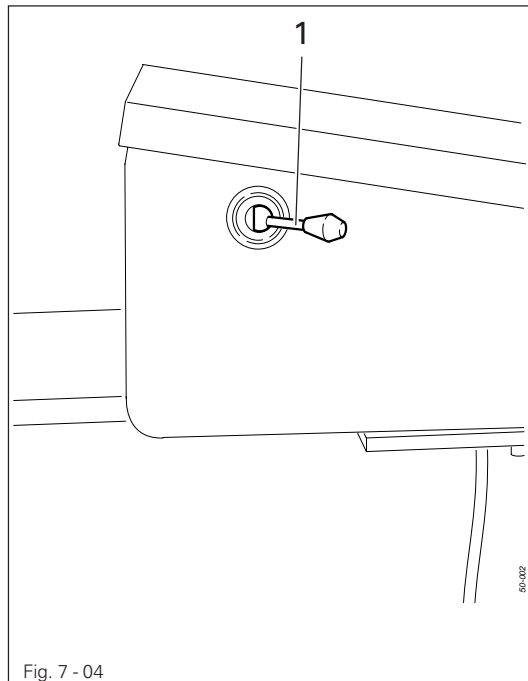

- The bundle clamp can be opened or closed with switch 1.



The bundle clamp is not part of the standard equipment of the machine.

	Contents	Chapter - Page
8	Installation and commissioning	8 - 1
8.01	Installation	8 - 1
8.01.01	Adjusting the table height	8 - 1
8.01.02	Assembling and fitting the reel stand	8 - 2
8.01.03	Fitting the bundle clamp (optional)	8 - 2
8.02	Commissioning	8 - 3
8.03	Switching the machine on/off	8 - 3

8 Installation and commissioning



The machine must only be installed and commissioned by qualified personnel!
All relevant safety regulations must be observed!

8.01 Installation

The site where the machine is installed must be provided with power connections (see **Chapter 3, Specifications**).

It must be ensured that the standing surface of the machine site is firm and horizontal, and that sufficient lighting is provided for.



For packing and transportation reasons the table top is in the lowered position.
The table height is adjusted as described below.

8.01.01 Adjusting the table height

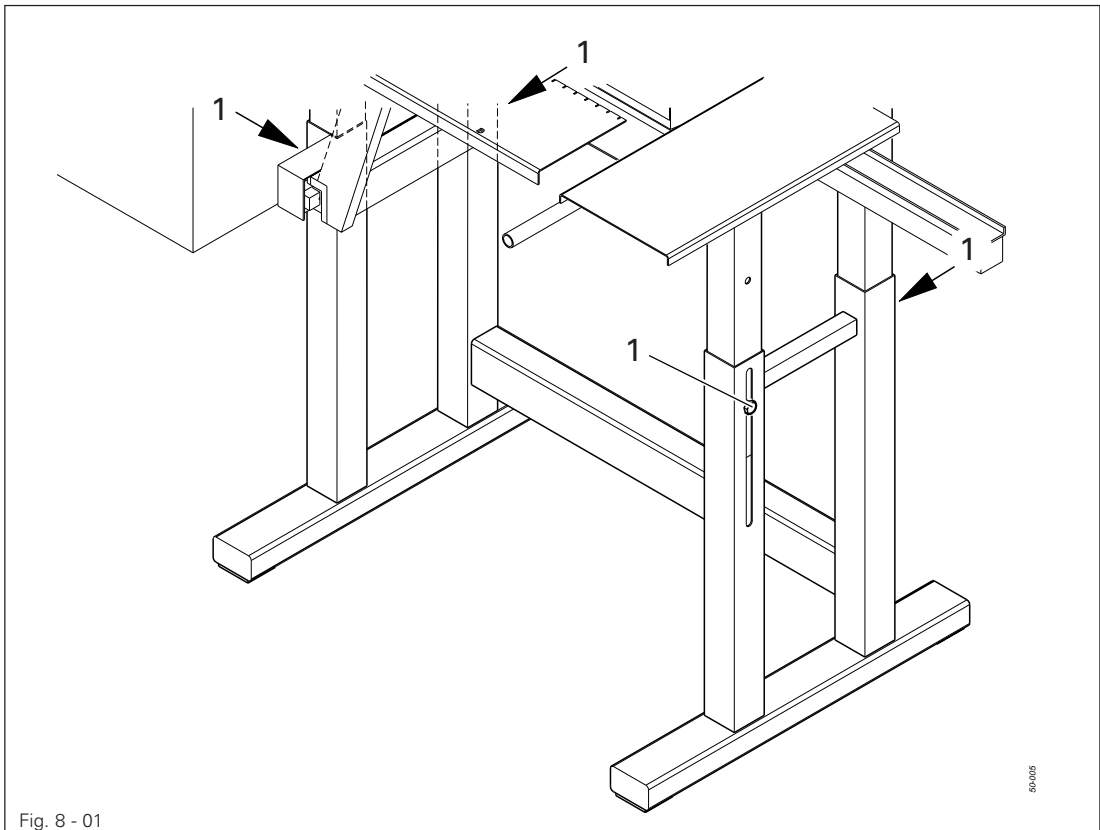

Fig. 8 - 01

- Loosen screws 1 and adjust table to required height.
- Well tighten screws 1 again.

8.01.02 Assembling and fitting the reel stand

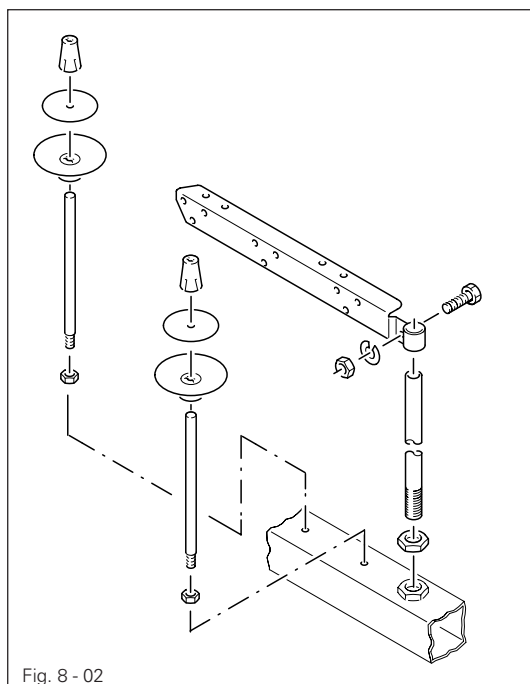

Fig. 8 - 02

- Assemble the reel stand as shown in Fig. 8-02.

8.01.03 Fitting the bundle clamp (optional)

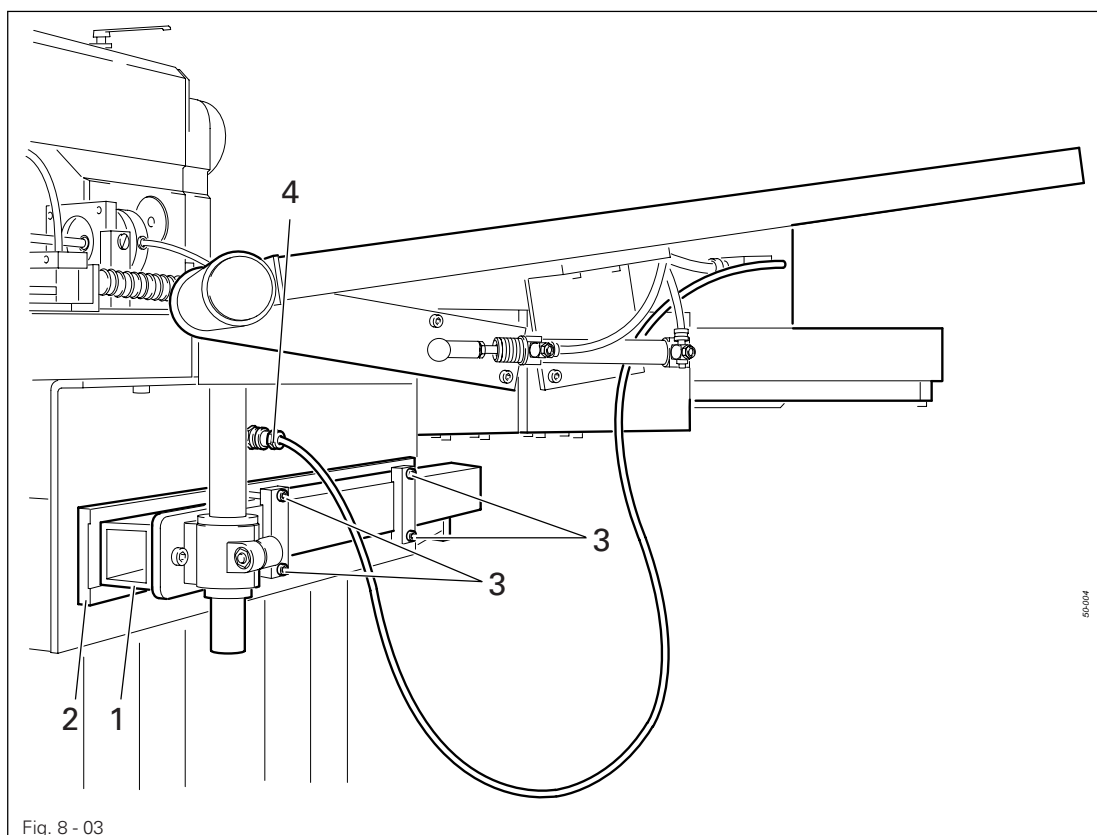

Fig. 8 - 03

- Insert bundle clamp with square bar 1 into the guide unit 2.
- Tighten screws 3.
- Plug in plug 4.

8.02 Commissioning

- Clean the entire machine thoroughly and check the electrical leads and pneumatic connection lines for any damage.
- Check whether the machine can be operated with the available mains connection (see **Chapter 3 Specifications**).
If there are any irregularities, do not operate the machine **under any circumstances!**
- Have specialists connect the machine to the mains.
- Oil the machine, or fill in oil (see **Chapter 12 Care and Maintenance**).
- Connect the machine to the compressed air system.
The manometer must display a pressure of **6 bar**.
If necessary, set to the correct value (see **Chapter 12.05 Checking/regulating air pressure**).

8.03 Switching the machine on/off

- Switch the machine on or off, see **Chapter 7.01 On/off switch**.



Before commissioning the machine, it is advisable to check the zero points, see **Chapter 13.08.06 Zero points of the drive units for X- and Y-axis**.

	Contents	Chapter - Page
9	Preparation	9 - 1
9.01	Inserting the needle	9 - 1
9.02	Threading the needle thread /adjusting the needle thread tension	9 - 2
9.03	Winding the bobbin thread, adjusting the thread tension	9 - 3
9.04	Changing the bobbin / adjusting the bobbin thread tension	9 - 4
9.05	Adjusting the height of the sewing foot	9 - 5
9.06	Selecting a language	9 - 5
9.07	Selecting a seam program	9 - 6

9

Preparation



All regulations and instructions in this Instruction Manual are to be observed!
Special attention is to be paid to the safety regulations!



All preparation work is only to be carried out by appropriately trained personnel.
Before all preparation work, the machine is to be separated from the electricity supply by removing the plug from the mains or switching off the On/Off switch!

9.01

Inserting the needle

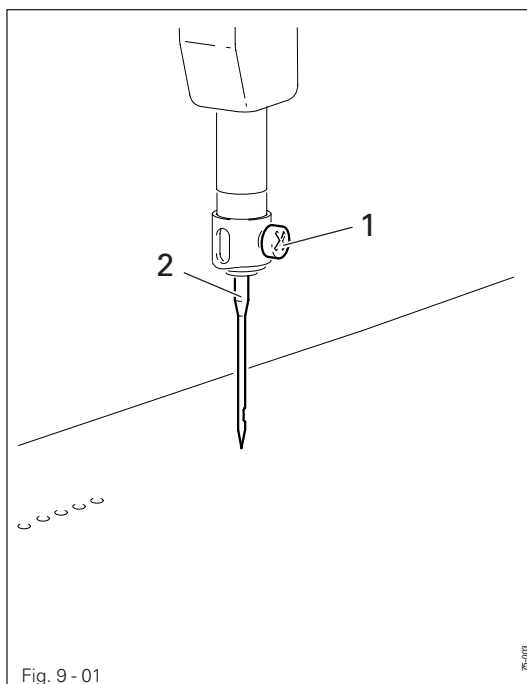

Only use system 134 KK needles!

- Switch on the machine, see **Chapter 8.03 Switching the machine on/off**.



- Select **SEWING** mode.



- Select **Threading aid** function (number key 5).
The pressure bar moves out of the needle area, the sewing foot is lowered and the sewing start is locked.

- Loosen screw **1** and remove needle **2**.

- Insert the new needle so that the long needle groove is facing forwards.

- Tighten screw **1**.



- Press the **Plus key**.
The machine is ready for operation again.

9.02 Threading the needle thread /adjusting the needle thread tension

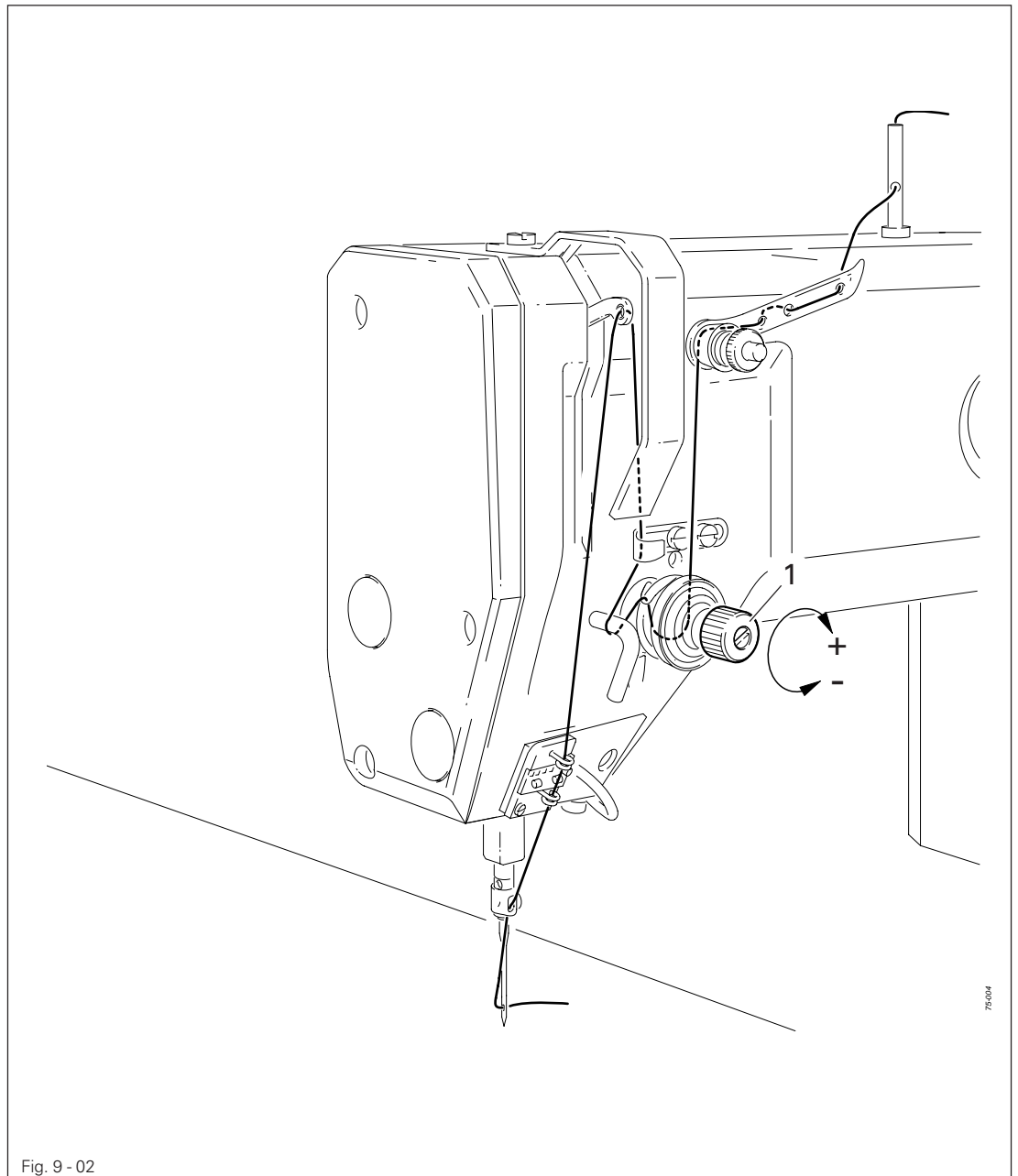

Fig. 9 - 02

- Switch on the machine, see Chapter 8.03 Switching the machine on/off.



- Select **SEWING** mode.



- Select **Threading aid** function (number key 5).

The pressure bar moves out of the needle area, the sewing foot is lowered and the sewing start is locked.

- Thread needle thread as shown in Fig. 9-02.
- Adjust the needle thread tension by turning the adjustment wheel 1.



- Press the **Plus** key.
The machine is ready for operation again.

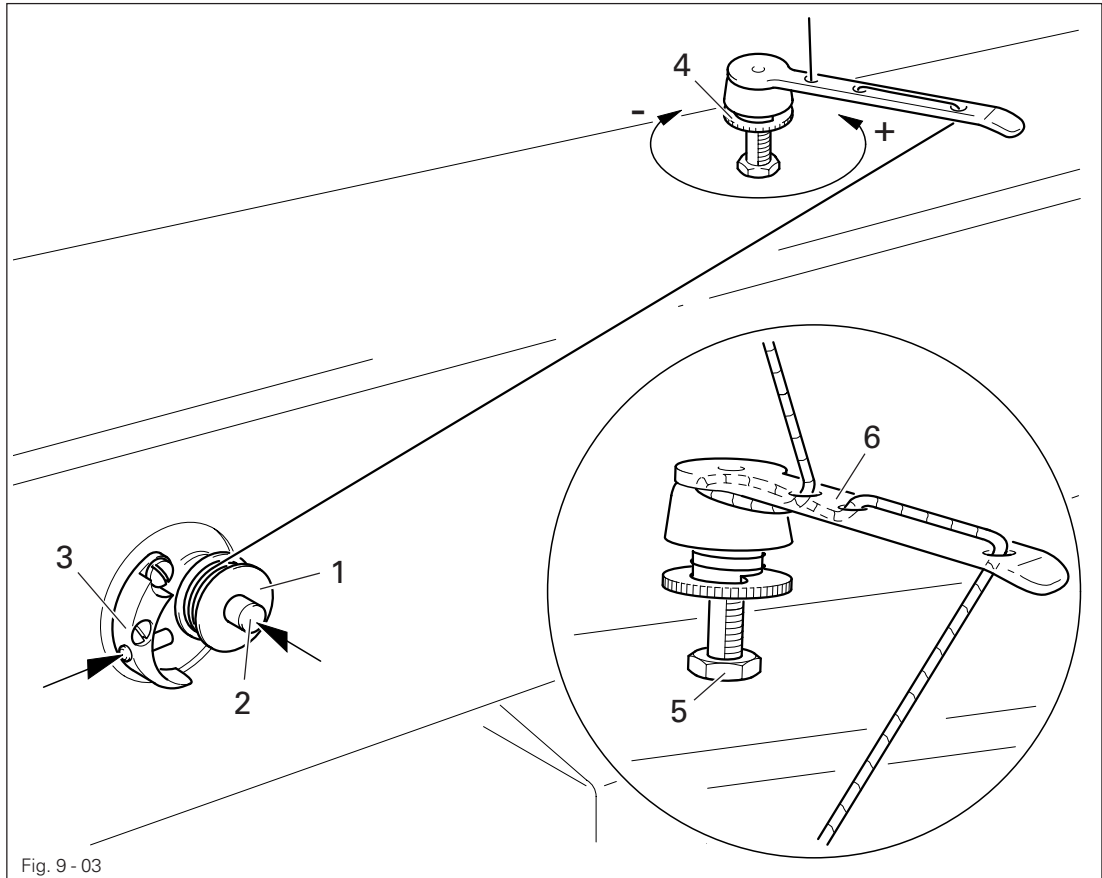

Fig. 9 - 03

- Place the empty bobbin 1 onto the bobbin winder spindle 2.
- Thread the thread in accordance with Fig. 09-03 and wind it a few times around bobbin 1 in an anti-clockwise direction.
- Switch the bobbin winder on by pushing the bobbin winder spindle 2 and lever 3 simultaneously.



The bobbin is wound during sewing.

- The tension of the thread on bobbin 1 can be adjusted using milled screw 4.
- The bobbin winder stops automatically when bobbin 1 is full.

If the thread is wound irregularly:

- Loosen nut 5.
- Turn thread guide 6 accordingly.
- Tighten nut 5.

9.04

Changing the bobbin / adjusting the bobbin thread tension

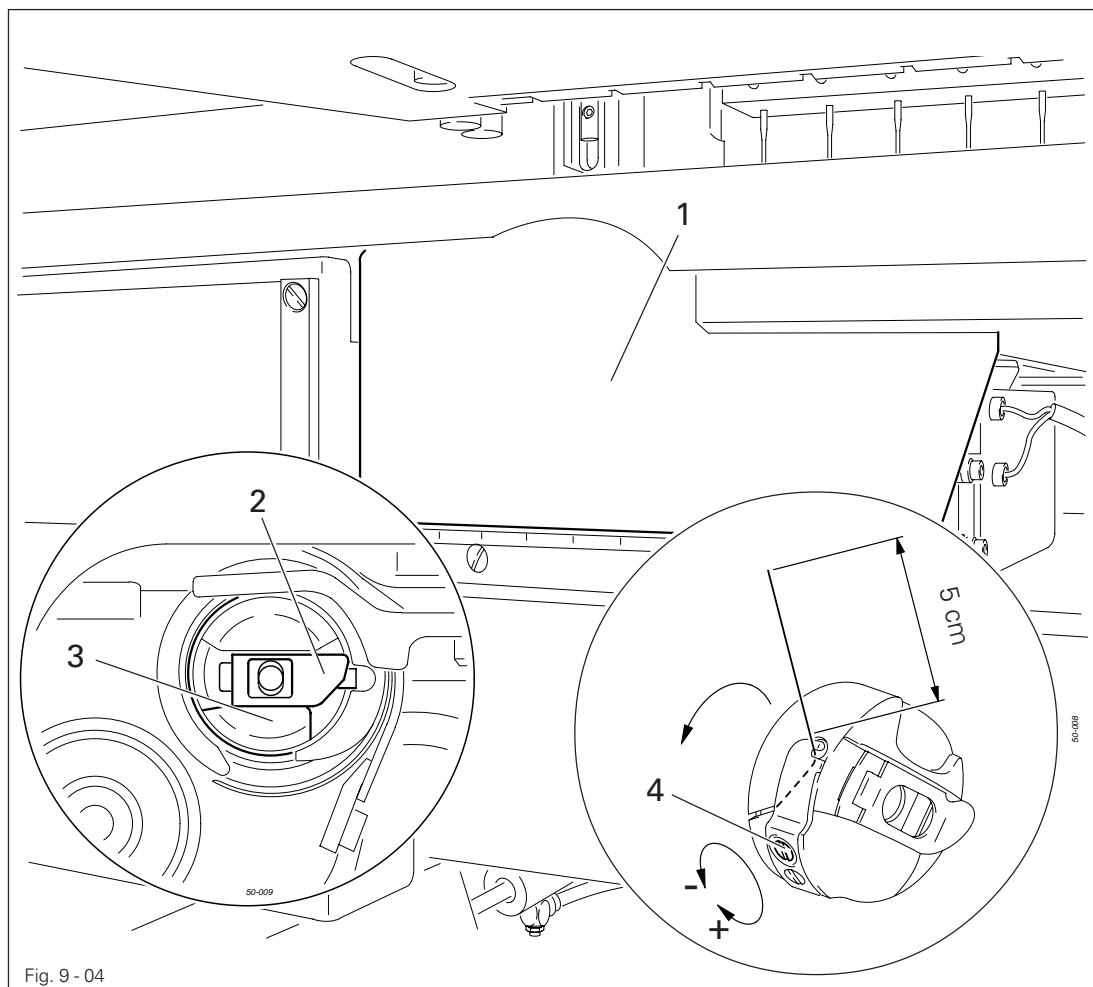

- Switch on the machine, see **Chapter 8.03 Switching the machine on/off**.



- Select **SEWING** mode.



- Select **Threading aid** function (number key 5).
The pressure bar moves out of the needle area, the sewing foot is lowered and the sewing start is locked.

- Open flap 1.
- Raise latch 2 and remove the bobbin case 3 together with the bobbin.
- Insert the filled bobbin into the bobbin case 3 so that the bobbin turns in the direction of the arrow when the thread is pulled out.
- Through the slot pull the thread under the spring as shown in **Fig. 9-04**.
- Adjust the bobbin thread tension by turning screw 4.
- Raise latch 2 and insert the bobbin case 3 together with the bobbin in the hook.
- Release latch 2 and press the bobbin case into the hook until you feel it lock into place.
- Close flap 1.



- Press the **Plus** key.
The machine is ready for operation again.

9.05 Adjusting the height of the sewing foot

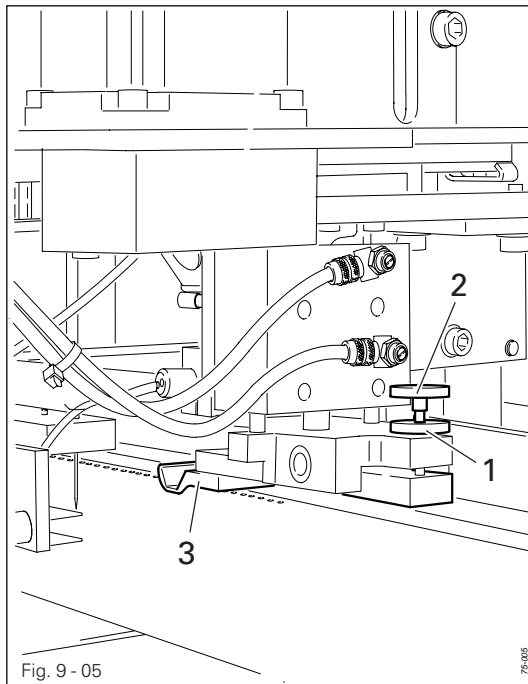

The sewing foot height is adjusted correctly when the sewing foot is positioned (suspended) slightly above the workpiece.

- Loosen counter screw **1** and adjust the presser foot **3** to the material thickness by turning milled screw **2**.
- Tighten counter screw **1** again.

9.06 Selecting a language



- Select **INPUT** mode by pressing the respective key.



Depending on the setting and configuration of the machine the displayed status bar may differ from the following example.

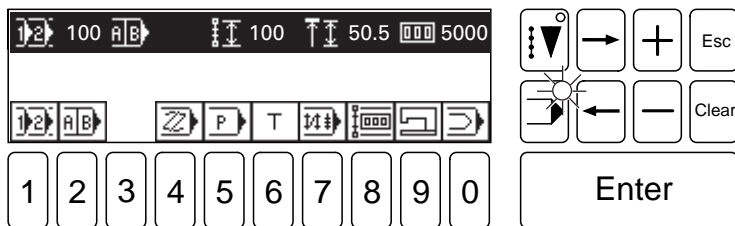

- Select the **input menu** function (number key 0).



- Select the **SWITCH FUNCTIONS** function with **number key 3**.



- Select the **LANGUAGES** function with **number key 2**.

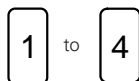

- Select the desired language with the **number keys 1 - 5**:

1 = **(D)** 3 = **(F)** 5 = **(TR)**

2 = **(GB)** 4 = **(E)**

- The language selected is assumed immediately once the corresponding number has been entered.

9.07 Selecting a seam program



- Switch on the machine and select **INPUT** mode.



Depending on the setting and configuration of the machine, in particular the status bar may differ from the following example.

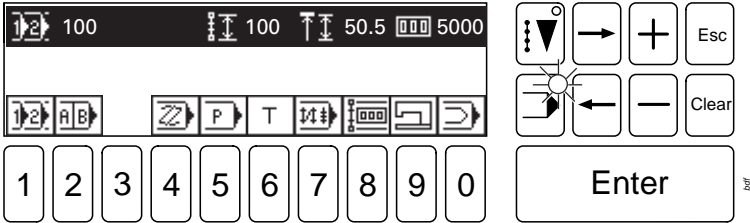

- Using the **Program number selection** (number key 1) or **Sequence number selection** (number key 2) function, select the required menu.

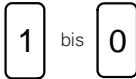

- Using the **number keys** select a previously entered seam program.

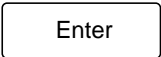

- Complete selection with **Enter**.



Seam programs can be transferred from a disk to the machine memory. To do so the **READ / WRITE PROGRAM** function must be selected (see **Chapter 11.05 Functions in INPUT mode**).



The **CREATE/MODIFY PROGRAM** function (see **Chapter 11.05 Functions in INPUT mode**) is used to create a seam program on the graphics control panel.

	Contents	Chapter - Page
10	Sewing	10 - 1
10.01	Status bar	10 - 1
10.02	Automatic Program Start	10 - 2
10.03	Manual Program Start	10 - 3
10.04	Sequence program	10 - 4
10.05	Error messages	10 - 5
10.06	Program interruption	10 - 5
11	Input	11 - 1
11.01	Summary of the functions in the INPUT mode	11 - 1
11.02	Summary of the functions in the input menu	11 - 2
11.03	Summary of the service functions	11 - 3
11.04	Selecting functions from the menu	11 - 4
11.05	Functions in the INPUT mode	11 - 6
11.06	Input of seam programs	11 -17
11.07	Examples for entering seam programs	11 -24
11.07.01	Straight dart	11 -24
11.07.02	Curved pleat	11 -26
11.08	CREATE/MODIFY FREE PROGRAMS	11 -29
11.08.01	Program structure	11 -29
11.08.02	Entering the free programming function	11 -29
11.08.03	Status bar in initial state (free programming)	11 -31
11.08.04	Summary of the functions in the initial state (free programming)	11 -32
11.08.05	Explanation of the functions in the initial state (free programming)	11 -33
11.08.06	Summary of the Insert functions	11 -36
11.08.07	Explanation of the insert functions	11 -37
11.08.08	An example for entering a free program	11 -40
11.09	Installing operating programs	11 -46
11.09.01	Booting for software updates	11 -46
11.09.02	Booting after changing the basic control unit	11 -47

10 Sewing



In the **SEWING** mode functions are available for production and production preparation. By pressing the corresponding key on the graphics control panel, the operational mode can be selected.

Before production begins, following work steps must be carried out:

- Prepare the machine, see **Chapter 9 Preparation**.
- Select **SEWING** mode.



In the SEWING mode, the program sequence can be started either automatically or manually, the differences are explained below in **Chapters 10.02 Automatic Program Start** and **10.03 Manual Program Start**.

- Insert the workpiece and start the program sequence.

Information and functions of the graphics control panel are listed below and explained.

10.01 Status bar

In the upper section of the display screen information is shown about the current machine status. For this purpose symbols are displayed with corresponding values.

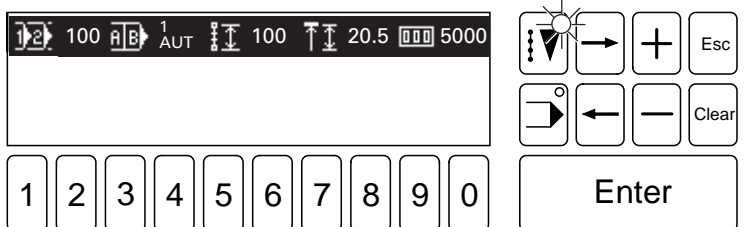

Explanation of the status bar symbols.



Program number

The number of the current program appears after the symbol for the program number.



No symbol appears for **standard programs**.



In the case of **sequence programs** the corresponding sequence number and the move-on method (automatic or manual) appears after the symbol.



Seam length

The value for the seam length of the selected seam program appears after this symbol.



Depth

The value for the programmed depth of the selected seam program appears after this symbol.



Piece counter

The actual number of pieces is shown after this symbol.

10.02 Automatic Program Start

In the case of an automatic program start, the program sequence begins as soon as the loading table with the workpiece is moved forward.

Starting position of the machine

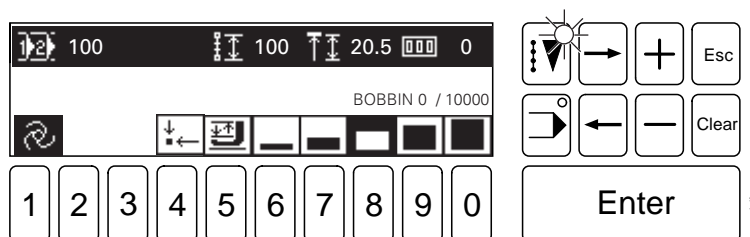

Explanation of the symbols in the pictogram bar:



Automatic program start (number key 1)

The pictogram indicates that the program starts automatically.

If the **Manual program start** function is selected, the machine switches over to this function, see **Chapter 10.03 Manual program start**.



Starting position (number key 4)

This is a direct function to bring the machine into its starting position.



Sewing foot up/down, threading aid (number key 5)

This is a direct function for raising or lowering the sewing foot. At the same time the pressure bar is switched on or off and if necessary moved into the threading position.



to



Depth correction dependent on the material (number keys 6 – 0)

The depth specified in the seam program is corrected according to the function selected.

The maximum value for the depth correction can be set in the input mode under the **Sewing head functions** function, see **Chapter 11.05 Functions in the INPUT mode**. The symbol for the selected depth correction appears on a dark background.



The depth correction value is reduced by **100%** of the specified depth.



The depth correction value is reduced by **50%** of the specified depth.



The specified depth remains unchanged.



The depth correction value is increased by **50%** of the specified depth.



The depth correction value is increased by **100%** of the specified depth.

10.03 Manual Program Start



In the case of a manual program start, the program sequence is started by selecting the **Start** function on the graphics control panel after the loading table has been moved forward.

Starting position of the machine

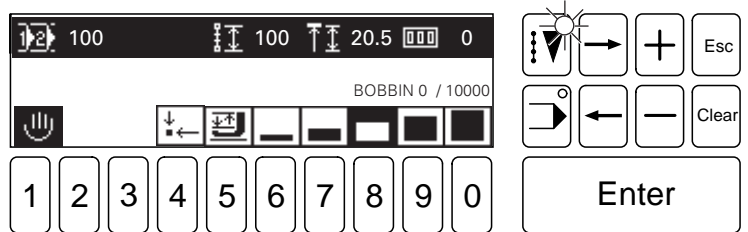

Explanation of the symbols in the pictogram bar:



Manual program start (number key 1)

The pictogram indicates that the program has been started manually.

If the **Automatic program start** function is selected, the machine switches over to this function, see **Chapter 10.02 Automatic program start**.



Starting position (number key 4)

This is a direct function to bring the machine into its starting position.



Sewing foot up/down, threading aid (number key 5)

This is a direct function for raising or lowering the sewing foot. At the same time the pressure bar is switched on or off and if necessary moved into the threading position.



to



Depth correction dependent on the material (number keys 6 – 0)

See **Chapter 10.02 Automatic program start**.

Loading table moved forward

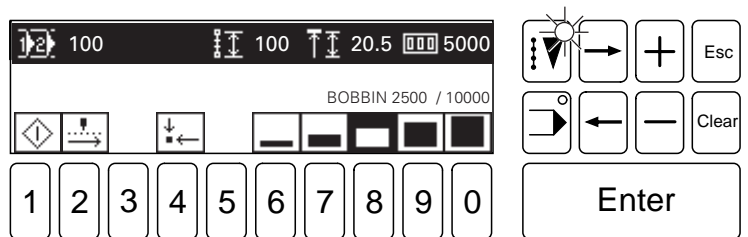

Explanation of the symbols changed in the pictogram bar:



Start (number key 1)

Direct function to start the program sequence.



Step-by-step forwards (number key 2)

With this function the seam pattern can be traced forwards step by step.

Machine running

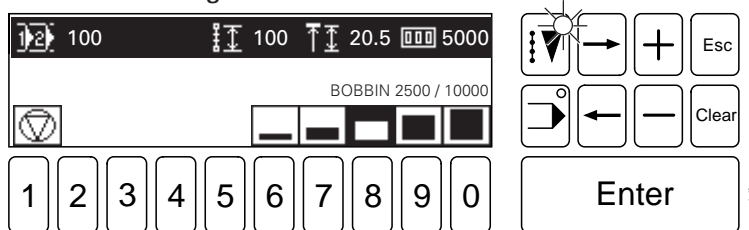

Explanation of the symbols in the pictogram bar:



Stop (number key 1)

Direct function to stop the entire program sequence
(see Chapter 10.06 Program interruption)



Depth correction dependent on the material (number keys 6 – 0)

See Chapter 10.02 Automatic program start.

Intermediate machine stop

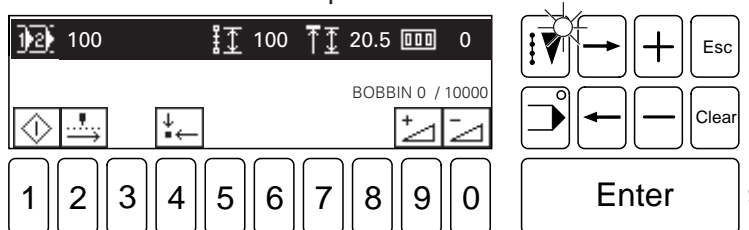

Explanation of the symbols in the pictogram bar:



Start (number key 1)

Direct function to continue the program sequence.



Step-by-step forwards (number key 2)

With this function the seam pattern can be traced forwards step by step.



Starting position (number key 4)

This is a direct function to bring the machine into its starting position.



Increase insertion depth (number key 9) / **Reduce insertion depth** (number key 0)

The insertion depth for this seam can be increased or reduced.

10.04 Sequence program

In sequence programs separate programs can be combined and saved under one program number. The selection of a sequence program and the move-on method can be recognised by the corresponding symbol in the status bar.

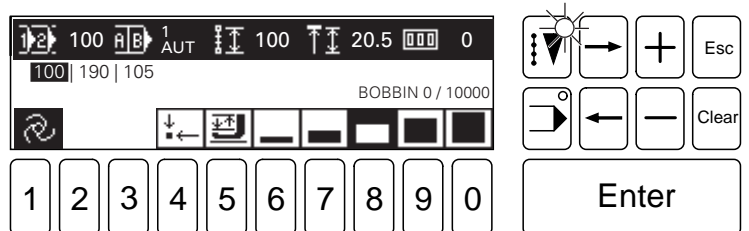

The sequence consists of the programs 100, 190 and 105.



Automatic switching to next sequence

The separate programs of the sequence are processed automatically after each other. The program number displayed on a dark background shows which part must be inserted next.



Manual switching to next sequence

The current program of a sequence is processed until another program is selected from the sequence.



Within the sequence the program is selected with the **arrow keys**.

The program number displayed on a dark background shows which program has been currently selected.

10.05 Error messages

If an error message occurs, text and pictogram bars in the display are written over. An error message can be caused by incorrect settings, defective elements or seam programs, as well as by overload conditions.

- Before machine operation can continue, the error must be corrected.

How to correct the error:

Enter

- Press **Enter** to move back to an incorrect input.
- Correct the input.

10.06 Program interruption



A program sequence can be interrupted by activating the **Stop** function on the graphics control panel.

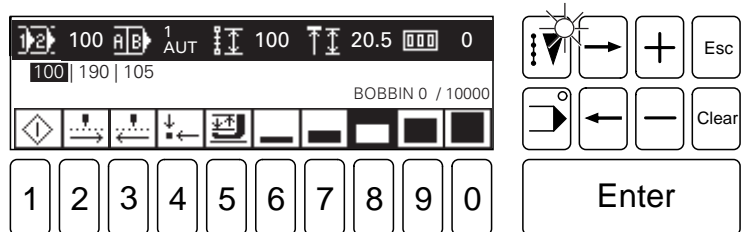

Explanation of the symbols in the pictogram bar:



Start (number key 1)

Direct function to continue the program sequence.



Step-by-step forwards (number key 2) / Step-by-step backwards (number key 3)

With this function the seam pattern can be traced forwards or backwards step by step.

Combined with the **Start** function, the seam pattern sequence runs automatically when the **Start** function is pressed in addition to the activated **Step-by-step...**function.



Starting position (number key 4)

This is a direct function to bring the machine into its starting position.



Sewing foot up / down, threading aid (number key 5)

This is a direct function for raising or lowering the sewing foot. At the same time the pressure bar is switched on or off and if necessary moved into the threading position.



Depth correction dependent on the material (number keys 6 – 0)

See Chapter 10.02 Automatic program start.

11 Input

This chapter lists and describes the functions in the **INPUT** mode. This operational mode includes the functions for program management, language selection, machine setting and configuration, as well as for service and adjustment work. However this chapter does not describe how to create a seam program. For information on how to create seam programs please refer to the relevant instruction manual.

11.01 Summary of the functions in the INPUT mode

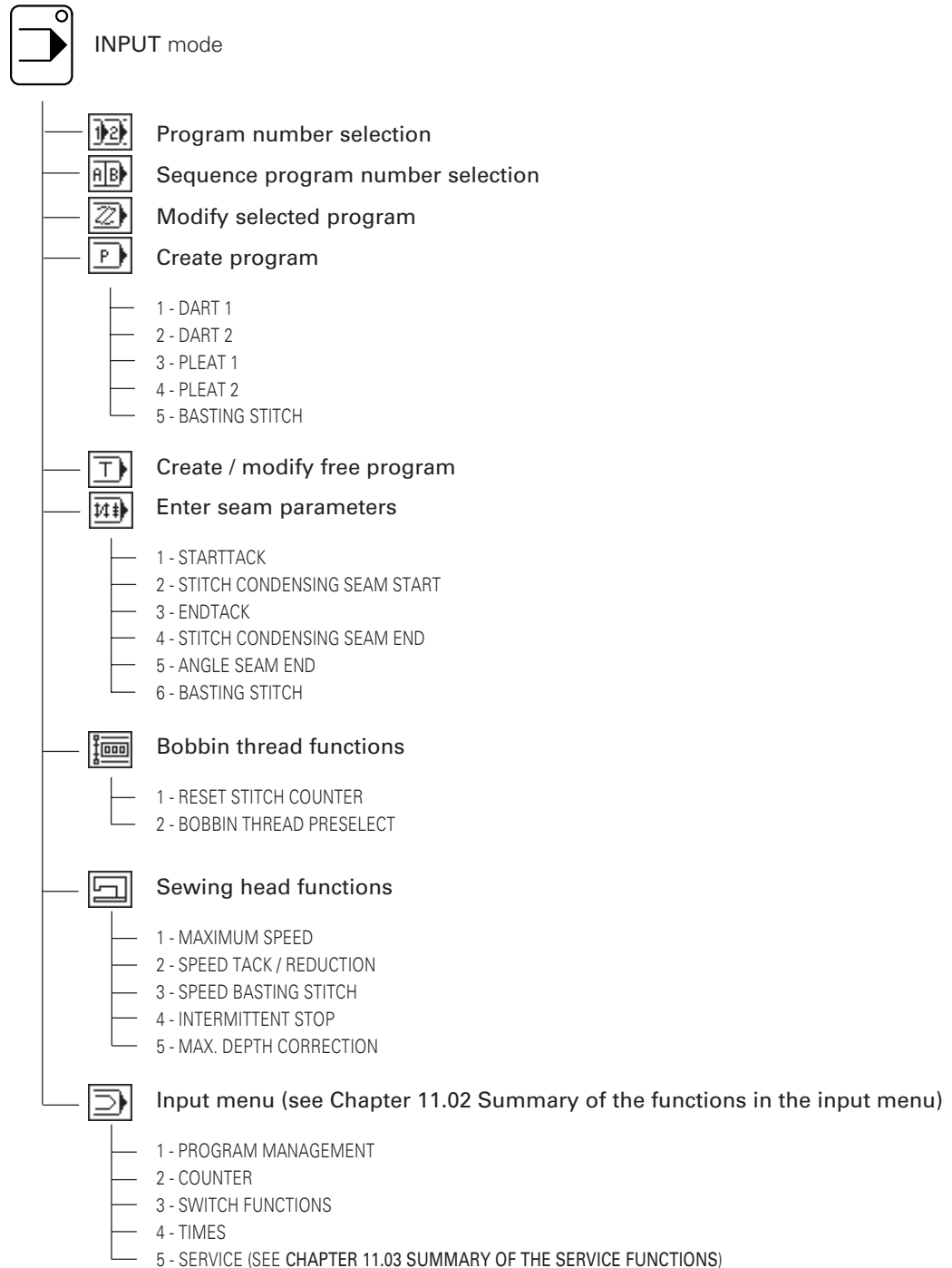

11.02 Summary of the functions in the input menu

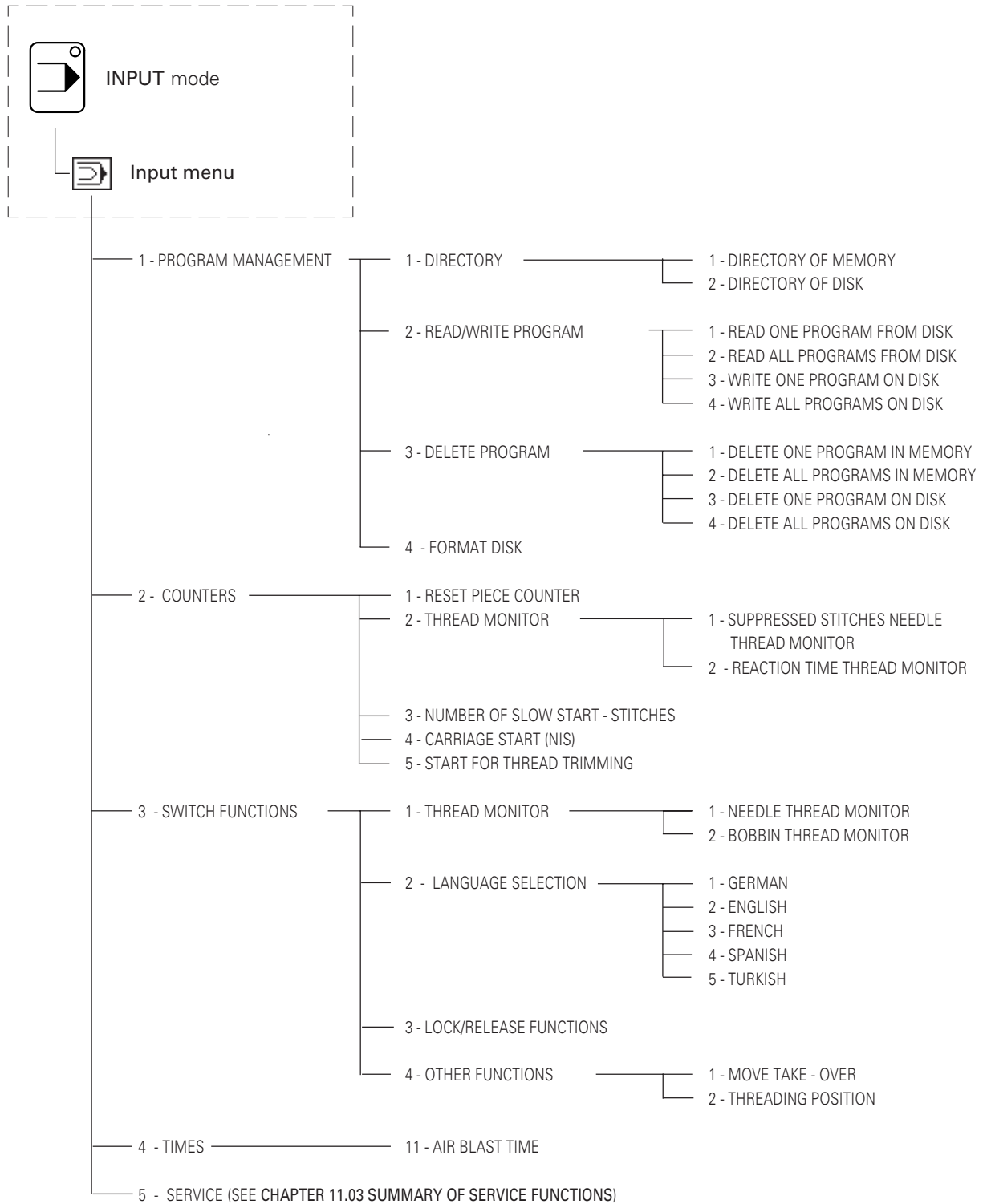

11.03 Summary of the service functions

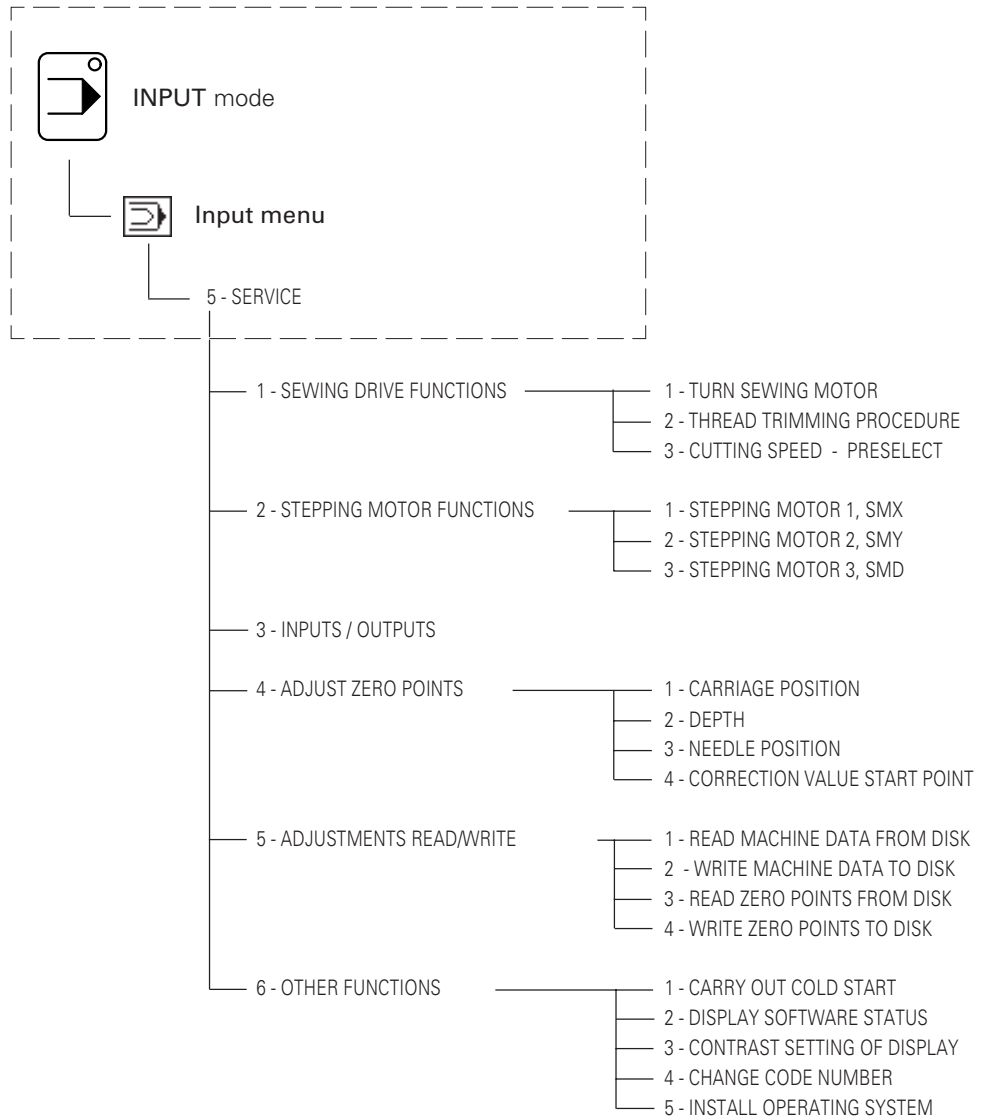

The service functions are explained in **Chapter 11.05 Functions in the INPUT mode.**

11.04 Selecting functions from the menu

An example is designed to show how to move about within menu levels.
Contrast setting of display:



- By pressing the corresponding key, select **INPUT** mode (LED in key lights up)

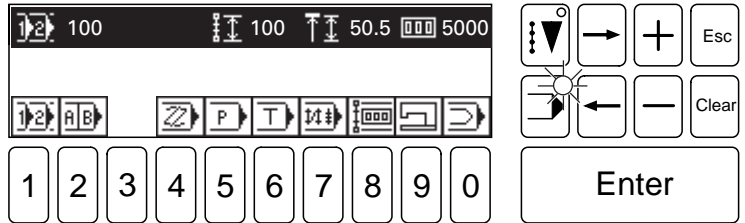

- Select **input menu** function (press number key 0)

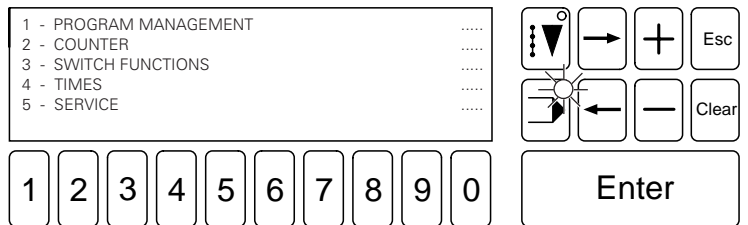

- By pressing **number key 5**, call up the **SERVICE** function.

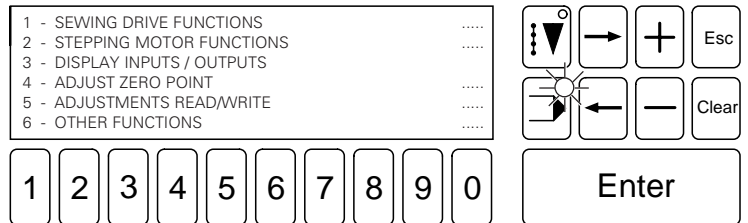

- With **number key 6** select **OTHER FUNCTIONS**.

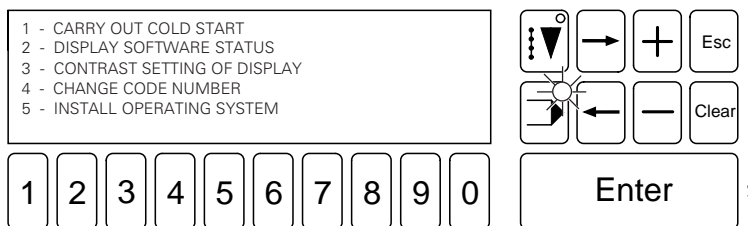

- Insert the code number (standard setting: 3586) using the **number keys**.

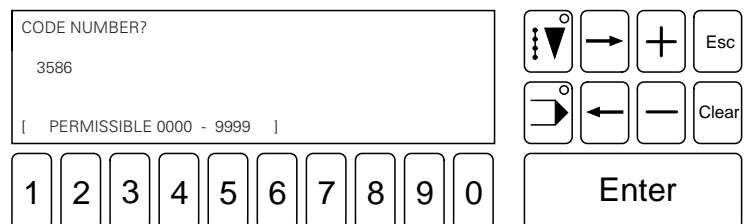

Enter

- Confirm code input with Enter.

3

- Select the CONTRAST SETTING OF DISPLAY function (number key 3)

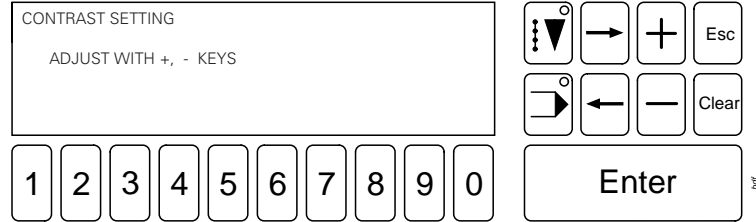

The contrast setting is changed immediately when the key is pressed and does not have to be confirmed with Enter. On no account may the contrast be reduced to such an extent that it is no longer possible to read the display!

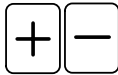

- The contrast can be changed as required using the **plus/minus** keys.

Enter

- Press **Enter** to exit the function.

Summary of the function selections



INPUT mode

0



Input menu function (number key 0)

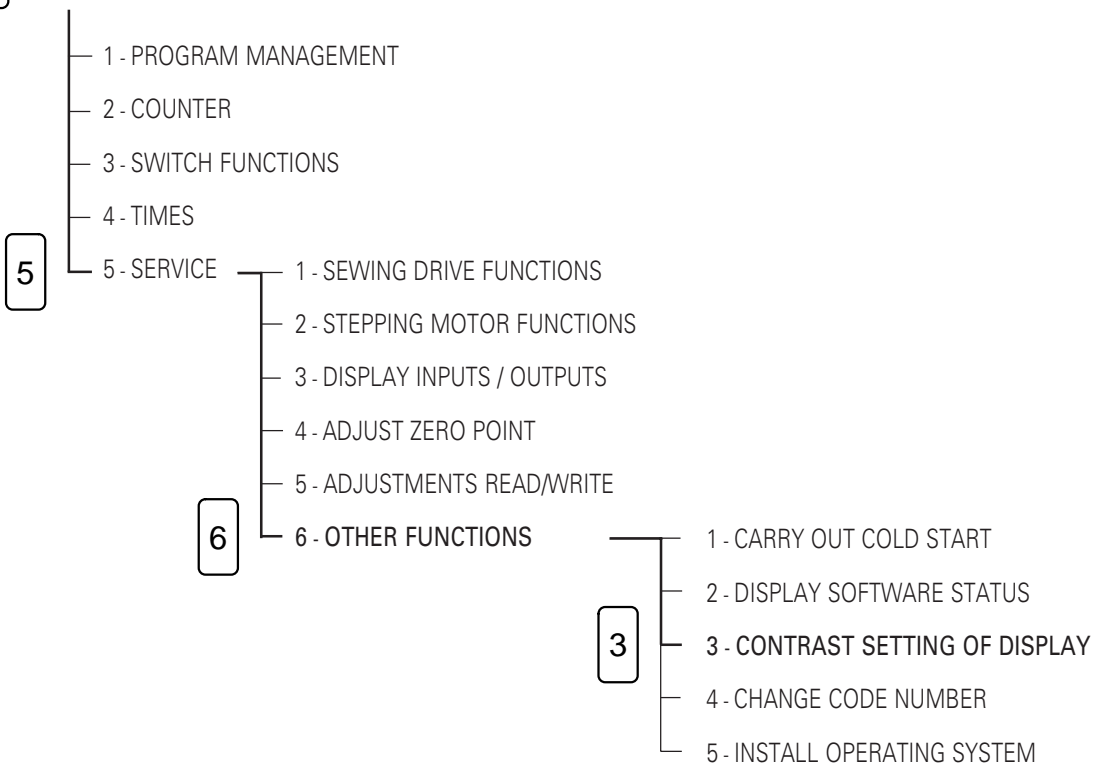

11.05 Functions in the INPUT mode

Initial state in the INPUT mode

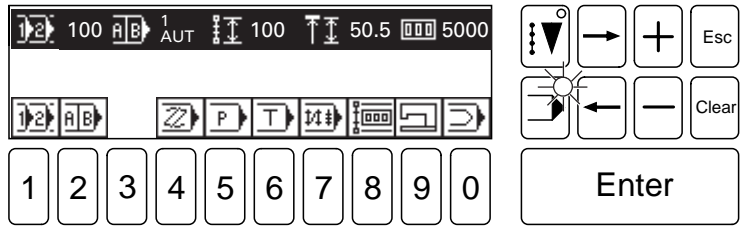

Explanation of the functions:



Program number selection (number key 1)

This function is for the selection of the desired program number.



Sequence program number selection (number key 2)

With this function it is possible to select the sequence program number, the method of moving the sequence forward and the sequence. When a sequence program number is selected, the sequence saved under this number is displayed.



Create / modify current program (number key 4)

With this function it is possible to create or modify the currently selected program using the graphics control panel.



Create / modify program (number key 5)

Using the graphics control panel with this function seam programs can be created or modified, the seam pattern and the corresponding program number are selected after the function has been called up, see **Chapter 11.06 Entering seam programs**.



Create / modify free program (number key 6)

With this function free seam programs can be created or modified on the machine, see **Chapter 11.07 Create / modify free program**.



Seam parameters (number key 7)

This function opens a menu for entering seam parameters:

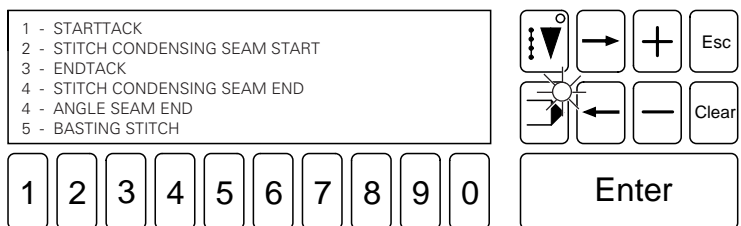

1

STARTTACK

With this function the number of stitches for the start backtack can be entered.

2

STITCH CONDENSING SEAM START

With this function the stitch length and number of condensed stitches at the seam start can be entered.

3

ENDTACK

With this function the number of stitches for the end backtack can be entered.

- 5 MAX: DEPTH CORRECTION
With this function the value for the maximum depth correction can be entered. The individual intermediate values are calculated automatically.



Input menu (number key 0)

This function opens a menu for selecting various functions from other menu levels

1 - PROGRAM MANAGEMENT
2 - COUNTER
3 - SWITCH FUNCTIONS
4 - TIMES
5 - SERVICE

1 2 3 4 5 6 7 8 9 0

Enter

- 1 PROGRAM MANAGEMENT
This function opens a menu for organizing seam programs:

1 - DIRECTORY
2 - READ/WRITE PROGRAM
3 - DELETE PROGRAM
4 - FORMAT DISK

1 2 3 4 5 6 7 8 9 0

Enter

- 1 DIRECTORY
This function opens a menu with functions for listing the directories of the memory:

1 - DIRECTORY OF MEMORY
2 - DIRECTORY OF DISK

1 2 3 4 5 6 7 8 9 0

Enter

- 1 DIRECTORY OF MEMORY
This function displays the contents of the machine memory.

- 2 DIRECTORY OF DISK
Displays the contents of a disk. Program numbers valid for this machine are displayed.

- 2 READ/WRITE PROGRAM
This functions opens a menu for transferring seam programs:

1 - READ ONE PROGRAM FROM DISK
2 - READ ALL PROGRAMS FROM DISK
3 - WRITE ONE PROGRAM ON DISK
4 - WRITE ALL PROGRAMS ON DISK

1 2 3 4 5 6 7 8 9 0

Enter

- 1 READ ONE PROGRAM FROM DISK
A selected program is read from a disk into the machine memory.
- 2 READ ALL PROGRAMS FROM DISK
All the programs on a disk are read into the machine memory.
- 3 WRITE ONE PROGRAM ON DISK
A selected program is written from the machine memory onto a disk.
- 4 WRITE ALL PROGRAMS ON DISK
All programs from the machine memory are written onto a disk.

- 3 DELETE PROGRAMS
The function opens a menu for deleting seam programs:

1 - DELETE ONE PROGRAM IN MEMORY
2 - DELETE ALL PROGRAMS IN MEMORY
3 - DELETE ONE PROGRAM ON DISK
4 - DELETE ALL PROGRAMS ON DISK

1 2 3 4 5 6 7 8 9 0

Esc
Clear
Enter

- 1 DELETE ONE PROGRAM IN MEMORY
A selected program is deleted in the machine memory.
- 2 DELETE ALL PROGRAMS IN MEMORY
All the programs in the machine memory are deleted.
- 3 DELETE ONE PROGRAM ON DISK
A selected program is deleted on a disk.
- 4 DELETE ALL PROGRAMS ON DISK
All the programs on a disk are deleted.
- 4 FORMAT DISK
Formats a disk and names it "K3586".



When you format a disk, all files on the disk are deleted!

2 COUNTER

This function opens a menu for customizing the counters:

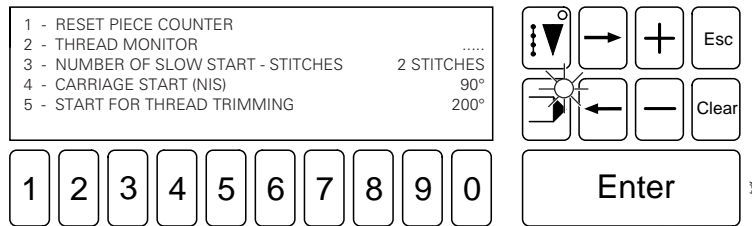

1 RESET PIECE COUNTER

With this function the piece counter is set at "0" for the daily production.

2 THREAD MONITOR

The function opens a menu for changing the thread monitor counters:

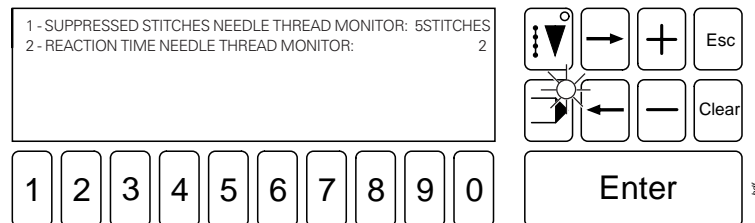

1 SUPPRESSED STITCHES NEEDLE THREAD MONITOR

Changes the number of stitches, for which the needle thread monitor is not active during sewing.

2 REACTION TIME, NEEDLE THREAD MONITOR

With this function the sensitivity of the needle thread monitor is changed (1 = quick reaction, max. sensitivity).

3 NUMBER OF SLOW START - STITCHES

Changes the number of stitches, which are to be sewn at reduced speed when sewing on a section of the workpiece.

4 CARRIAGE START (NIS)

This function changes the time for starting the motors of the carriage drive. (° = degrees after t.d.c. needle bar).

5 START FOR THREAD TRIMMING

Changes the time at which the impulse to start thread trimming is sent to the thread trimming valve (° = degrees after t.d.c. needle bar).

3 SWITCH FUNCTIONS

This function opens a menu for switching machine functions on or off.

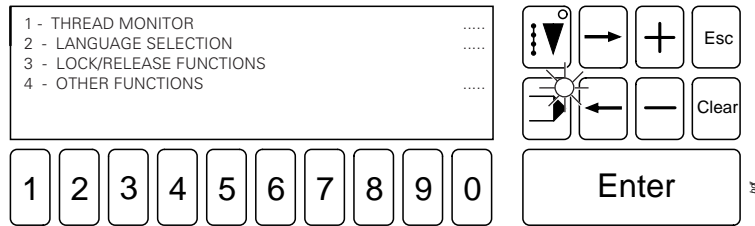

1 THREAD MONITOR

This function opens a menu for selecting thread monitors:

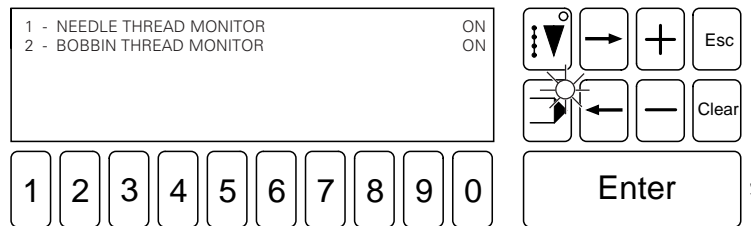

1 NEEDLE THREAD MONITOR

With this function the needle thread monitor is switched on or off.

2 BOBBIN THREAD MONITOR

This function counts the stitches.

2 LANGUAGE SELECTION

This function opens a menu for the selection of the languages displayed (see **Chapter 9.06 Language selection**):

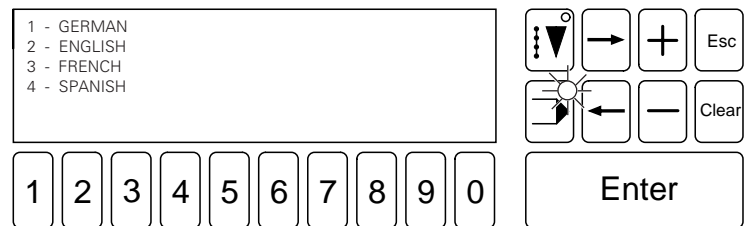

3 LOCK/RELEASE FUNCTIONS

With this function all functions in the **INPUT** mode can be released, secured with a code number and made accessible to authorized personnel only by means of a key.

A table with the code numbers of the individual functions can be found in **Chapter 14.03.01 Tables for lock/release functions**.

- 4 OTHER FUNCTIONS
This function opens a menu for switching the other functions on or off.

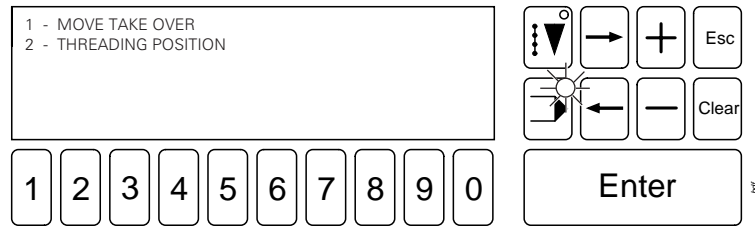

- 1 MOVE TAKE OVER
When this function is switched on, the material take over is moved automatically by a certain amount during the sewing cycle.
- 2 THREADING POSITION
When the threading aid function is switched on, the pressure bar is moved.

- 4 TIMES
This function opens a menu for altering the time settings.

- 1 AIR BLAST TIME
This function is used to set the duration of the air blast for blasting out the material at the end of the seam.

5 SERVICE

This functions opens a menu for selecting the service functions:

1 - SEWING DRIVE FUNCTIONS	
2 - STEPPING MOTOR FUNCTIONS	
3 - DISPLAY INPUTS/OUTPUTS	
4 - ADJUST ZERO POINT	
5 - ADJUSTMENTS READ/WRITE	
6 - OTHER FUNCTIONS	

1 2 3 4 5 6 7 8 9 0 Enter

1 SEWING DRIVE FUNCTIONS

This function opens a menu for checking the sewing motor:

1 - TURN SEWING MOTOR		
2 - THREAD TRIMMING PROCEDURE	200 RPM	
3 - CUTTING SPEED - PRESELECT		

1 2 3 4 5 6 7 8 9 0 Enter



Before activating the following functions, make sure that the needle can enter the needle hole without any problem!

1 TURN SEWING MOTOR

With his function the sewing motor can be started and stopped again. The speed can be pre - selected or even altered during running, using the **plus/minus keys**.

2 THREAD TRIMMING PROCEDURE

This function starts the thread trimming procedure.

3 CUTTING SPEED - PRESELECT

This function preselects the positioning speed for thread cutting.

2 STEPPING MOTOR FUNCTIONS

This function opens a menu for moving the stepping motors:

1 - STEPPING MOTOR 1 (X)		
2 - STEPPING MOTOR 2 (Y)		
3 - STEPPING MOTOR 3 (D)		

1 2 3 4 5 6 7 8 9 0 Enter



Before activating the following functions, make sure that the carriage drive can move freely!

1 STEPPING MOTOR 1 (X)

This function moves stepping motor 1 (X - axis).

- 2 STEPPING MOTOR 2 (Y)
This function moves stepping motor 2 (Y - axis).
- 3 STEPPING MOTOR 3 (D)
This function moves stepping motor 2 (depth).

- 3 DISPLAY INPUTS/OUTPUTS
After this function has been selected, the states of inputs and outputs are displayed:
1 = Input actuated / output switched
0 = Input not actuated / output not switched

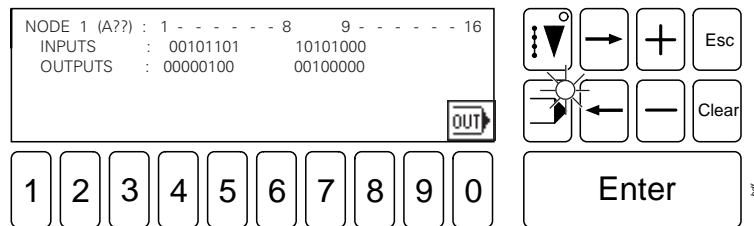

-  With this function (number key 0) a menu is opened, in which outputs can be set or reset. The required output is selected with a code number. A signal is given for any errors occurring. In the case of outputs equipped with a transmitter for sending a response signal, the response time is measured and displayed.
There is a table of the inputs and outputs with code numbers in **Chapter 14.03 Tables**.

- 4 ADJUST ZERO POINT
This function opens a menu for adjusting the zero points

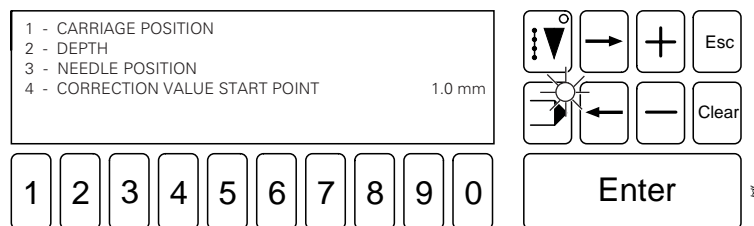

- 1 CARRIAGE POSITION
With this function the basic position of the carriage can be set.
- 2 DEPTH
With this function the distance between material take over and pressure bar can be set.
- 3 NEEDLE POSITION
This function sets the position "TDC needle bar".
- 4 CORRECTION VALUE START POINT
With this function it is possible to correct the seam starting point in X - direction.

5 ADJUSTMENTS READ/WRITE

After this function has been called up, a menu is opened for entering or copying machine data:

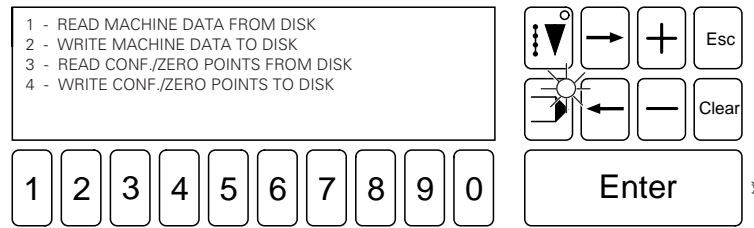

1 READ MACHINE DATA FROM DISK

With this function it is possible to read machine data (file name: MDAT) which is saved on a disk, into the machine memory (e.g. after a cold start).

2 WRITE MACHINE DATA TO DISK

With this function the data for the machine setting (file name: MDAT) can be written on to a disk.

There is a table of transferable machine data in the service manual for this machine.

3 READ CONFIGURATION/ZERO POINTS FROM DISK

With this function it is possible to read the machine configuration and the zero points (file name: KONF), which are saved on a disk, into the machine memory (e.g. after a master reset).

4 WRITE CONFIGURATION/ZERO POINTS TO DISK

With this function it is possible to write the machine configuration and the zero points (file name: KONF) on to a disk.

OTHER FUNCTIONS

This function opens a menu with various other functions:

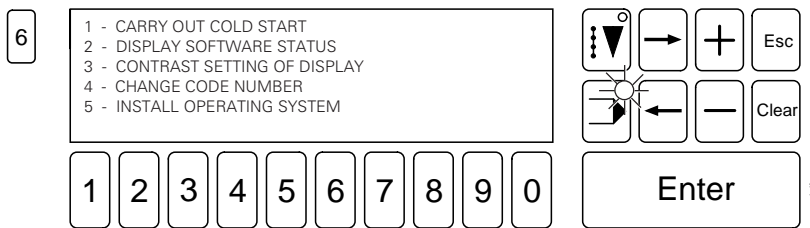

1 CARRY OUT COLD START

With this function a cold start can be carried out.

During this procedure all settings, except the zero point settings and the machine configuration, are returned to the initial load status; all programs in the machine memory are deleted.

2 DISPLAY SOFTWARE STATUS

After this function has been selected, the part numbers of the machine software and the software versions of various controllers are displayed.

3 CONTRAST SETTING OF DISPLAY



Under no circumstances may the display be adjusted to such an extent, that it is no longer possible to read the display.

With this function the contrast setting of the display can be altered.

4 CHANGE CODE NUMBER

After a cold start, this number is **3586**. This function allows you to select your own code number from 0000 - 9999.



Functions secured by a code number can only be selected with the respective code.

5 INSTALL OPERATING SYSTEM

With this function, after the boot disk K3586BOOT1 has been inserted, the operating software is loaded for a software update, see **Chapter 11.09 Installing operating programs**.

11.06 Input of seam programs



Seam programs can be created or modified with the graphics control panel, using the **Create/Modify program** function. After the function has been selected, the seam type and corresponding program number can be selected.

The selection of the seam type depends on the additional seam requirements:

	DART 1	DART 2	PLEAT 1	PLEAT 2
Starttack	pre - set	pre - set	pre - set	pre - set
Stitch condensing seam start	optional	optional	optional	optional
End tack	not possible	not possible	pre - set	not possible
Stitch condensing seam end	automatic	automatic	optional	automatic
Angle seam end	automatic	automatic	not possible	not possible
Basting stitch	not possible	not possible	optional	optional

Basic status of the seam program input

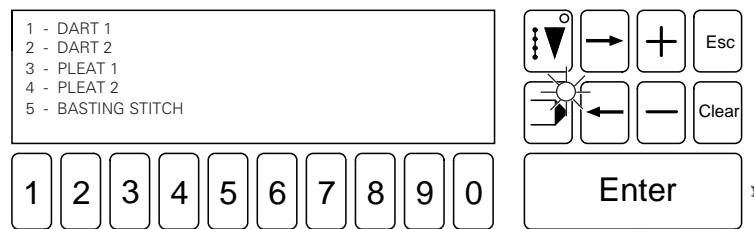

- After the required seam type has been selected (number keys 1 to 5), the program number must be entered.

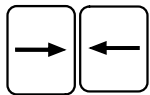

Use the **arrow keys** to enter the program number or stitch length in the basic pattern of each seam type.

1

DART 1

With this function the corresponding seam type can be programmed.

Program numbers 100 - 199 are allocated to the seam type "Dart 1"

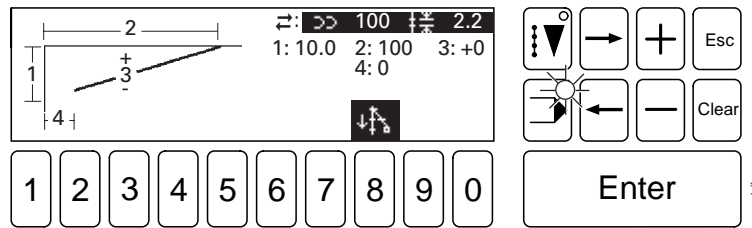

1

Number key 1

Press this number key to enter the value for **dart depth**.

2

Number key 2

Press this number key to enter the value for **dart length**.

3

Number key 3

Press this number key to enter the value for **curve**.

4

Number key 4

Press this key to enter the value for **shifting the starting point**.





Starttack / stitch condensing seam start (number key 8)

With this function it is possible to define the type of seam starttack. By pressing a key it is possible to select either a tack or stitch condensation at the beginning of the seam.

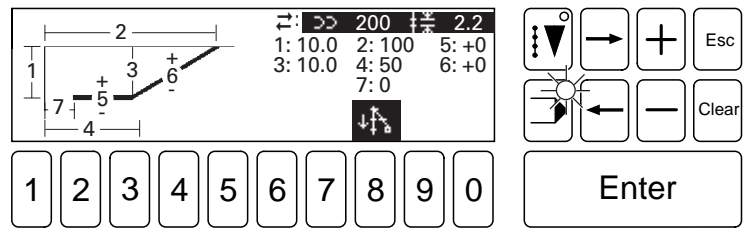
- 2 DART 2
 With this function the corresponding seam type can be programmed.
 Program numbers 200 - 299 are allocated to the seam type "Dart 2"



- 1 Number key 1
 Press this number key to enter the value for **dart depth**.
- 2 Number key 2
 Press this number key to enter the value for **dart length**.
- 3 Number key 3
 Press this number key to enter the value for **depth at waist**.
- 4 Number key 4
 Press this number key to enter the value for **length at waist**.
- 5 6 Number key 5 / number key 6
 Press these number keys to enter the values for **curve**.
- 7 Number key 7
 Press this key to enter the value for **shifting the starting point**.
-   **Starttack / stitch condensing seam start** (number key 8)
 With this function it is possible to define the type of seam starttack. By pressing a key it is possible to select either a tack or stitch condensation at the beginning of the seam.

3

PLEAT 1

With this function the corresponding seam type can be programmed.
Program numbers 300 - 399 are allocated to the seam type "Pleat 1".

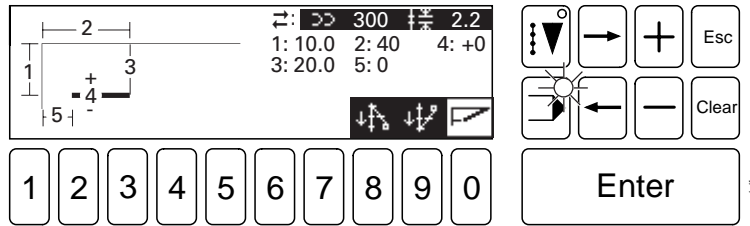

1

Number key 1

Press this number key to enter the value for **pleat depth**.

2

Number key 2

Press this number key to enter the value for **pleat length**.

3

Number key 3

Press this number key to enter the value for **depth at hip**.

4

Number key 4

Press this number key to enter the value for **curve**.

5

Number key 5

Press this key to enter the value for **shifting the starting point**.



Starttack / stitch condensing seam start (number key 8)

With this function it is possible to define the type of seam starttack. By pressing a key it is possible to select either a tack or stitch condensation at the beginning of the seam.



End tack / Stitch condensing seam end (number key 9)

With this function it is possible to define the type of seam end tack. By pressing a key it is possible to select either a tack or stitch condensation at the end of the seam.



Basting stitch (number key 0)

With this function it is possible to attach a basting stitch.

(The symbol for the currently selected type of basting stitch is always displayed).

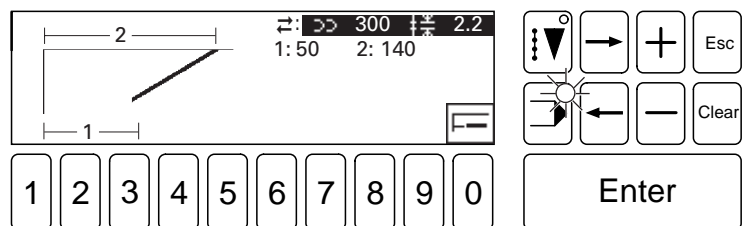

The depth of the basting stitch corresponds to the depth of the pleat at the hip. The beginning, end and type of basting stitch can be defined with the following functions.

- 1 **Number key 1**
After pressing this key, the value for the **basting stitch start** can be entered.
- 2 **Number key 2**
After pressing this key, the value for the **basting stitch end** can be entered.



Basting stitch type (number key 0)
After pressing this key it is possible to select two different types of basting stitches. The symbol for the currently selected basting stitch type is displayed.

- 4 **PLEAT 2**
With this function the corresponding seam type can be programmed. Program numbers 400 - 499 are allocated to the seam type "Pleat 2".

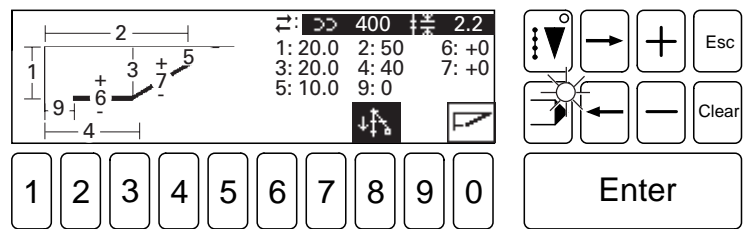

- 1 **Number key 1**
Press this number key to enter the value for **pleat depth**.
- 2 **Number key 2**
Press this number key to enter the value for **pleat length**.
- 3 **Number key 3**
Press this number key to enter the value for **depth at hip**.
- 4 **Number key 4**
Press this number key to enter the value for **length at hip**.
- 5 **Number key 5**
Press this key to enter the value for **end of pleat depth**.



Number key 6 / number key 7

Press this number key to enter the value for **curve**.



Number key 9

Press this key to enter the value for **shifting the starting point**.



Starttack / stitch condensing seam start (number key 8)

With this function it is possible to define the type of seam starttack. By pressing a key it is possible to select either a tack or stitch condensation at the beginning of the seam.



Basting stitch (number key 0)

With this function it is possible to attach a basting stitch.

(The symbol for the currently selected type of basting stitch is always displayed).

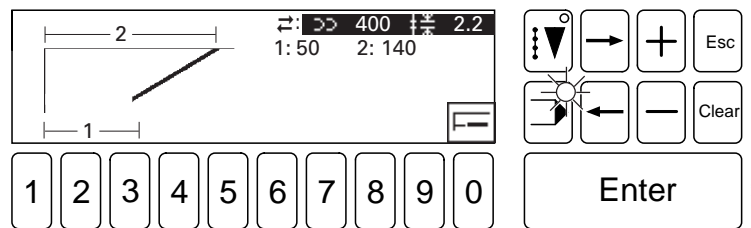

The depth of the basting stitch corresponds to the depth of the pleat at the hip. The beginning, end and type of basting stitch can be entered as described above under the function "PLEAT 1".

5 BASTING STITCH

With this function the corresponding seam type can be programmed.

Program numbers 500 - 599 are allocated to the seam type "Basting stitch"

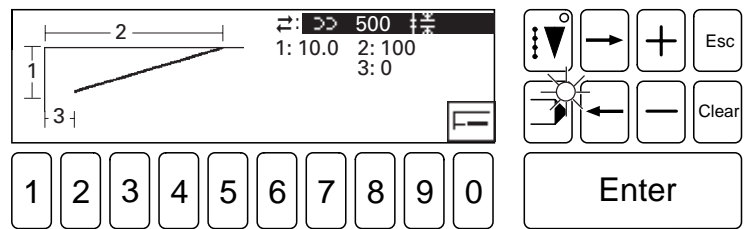

1 Number key 1
Press this number key to enter the value for **basting stitch depth**.

2 Number key 2
Press this number key to enter the value for **basting stitch length**.

3 Number key 3
Press this key to enter the value for **shifting the starting point**.



Basting stitch type (number key 0)

By pressing the number key several times, it is possible to select 2 different types of basting stitch. The symbol for the currently selected basting stitch type is displayed.

11.07 Examples for entering seam programs

11.07.01 Straight dart

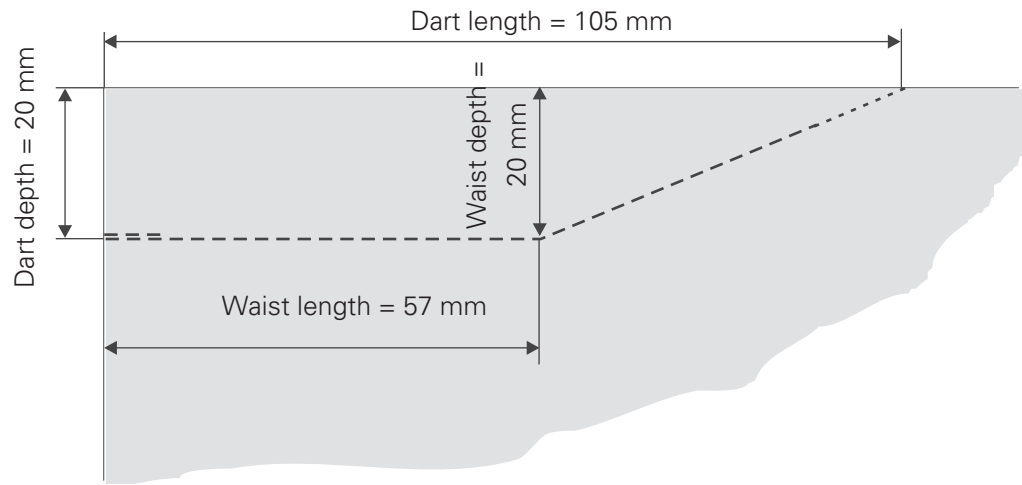

- To create a seam pattern, **seam type "Dart 2"** must be used.
- From the program group stipulated for this seam type (200 - 299), **program number 222** should be selected for the seam program.
- The **stitch length** must be **2.0 mm**.
- **Backtacking stitches** should be carried out at the beginning of the seam.



- Switch on the machine and select **INPUT mode**.



- Select the **Create program** function (number key 5)



- Select the **DART 2** function.



- Enter the program number.

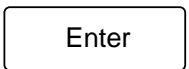

- Press **Enter**.

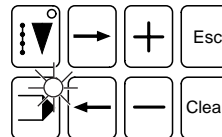
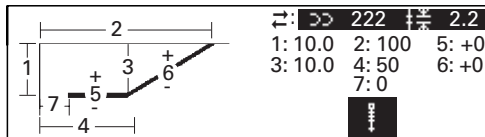

- Using the **left arrow** key move to stitch length input.



- Enter the stitch length.

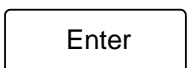

- Press **Enter**.

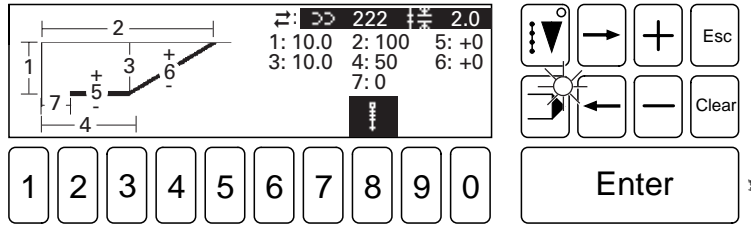

1 ● Press number key 1.

2 0 0 ● Enter dart depth (value 1).

Enter ● Press Enter.
A move is made to the input of the dart length (value 2).

1 0 5 ● Enter dart length.

2x Enter ● Press Enter.
If the **Enter** key is pressed once, a move is made to the curve input (value 5), this value should remain unchanged (no curve).
To enter the waist depth **Enter** must be pressed again.

2 0 0 ● Enter the waist depth.

Enter ● Press Enter.
A move is made to the input for waist length (value 4)

5 7 ● Enter waist length.

3x Enter ● Press **enter** three times.
(The remaining values 5-7 should remain unchanged).

 ● Press number key 8 until the symbol for **Starttack** appears on the display.

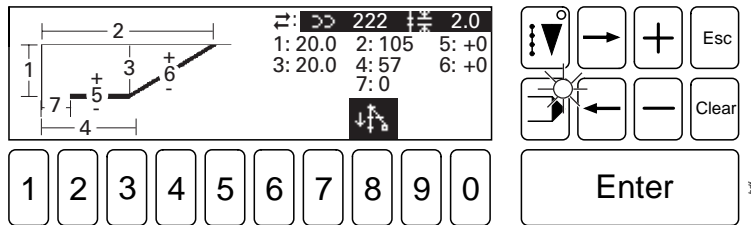



- Select **SEWING** mode, to end the seam program input.
The values are checked and the seam pattern calculated. If errors are detected, these are displayed with a relevant error message.

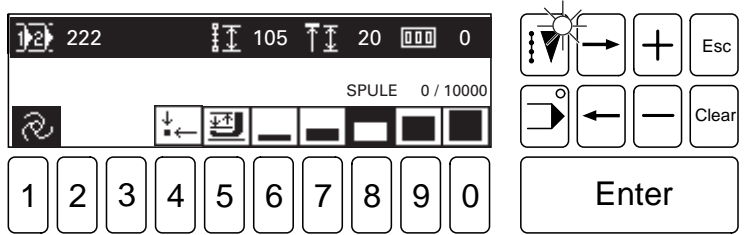

11.07.02 Curved pleat

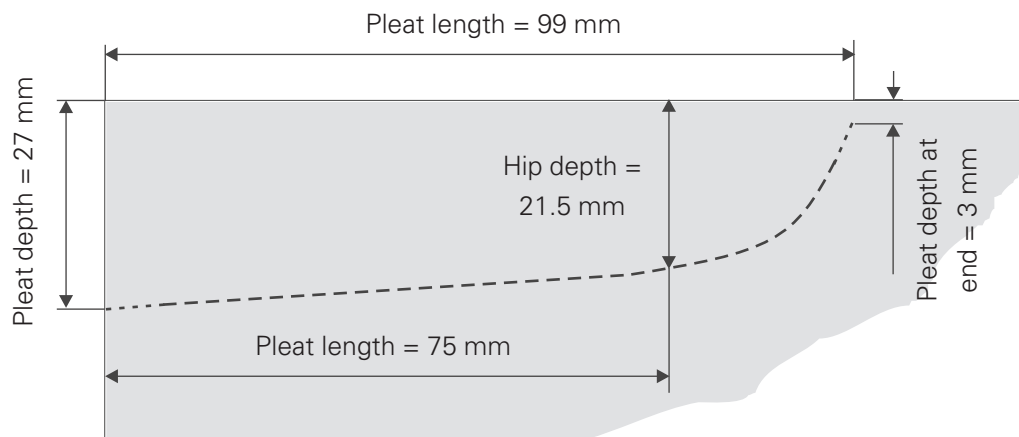

- To create a seam pattern, **seam type "Pleat 2"** must be used.
- From the program group stipulated for this seam type (400 - 499), **program number 444** should be selected for the seam program.
- The **stitch length** must be **1.8 mm**.
- **Condensed start stitches** should be carried out at the beginning of the seam.



- Switch on the machine and select **INPUT mode**.



- Select the **Create program** function (number key 5)



- Select the **PLEAT 2** function.



- Enter the program number.

Enter

- Press **Enter**.

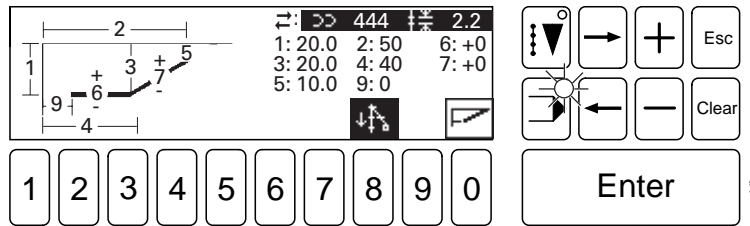

● Using the **left arrow key** move to stitch length input.



● Enter the stitch length.

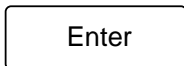

● Press **Enter**.



● Press number key 1.



● Enter pleat depth (value 1).

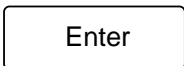

● Press **Enter**.

A move is made to the input of the pleat length (value 2).



● Enter pleat length.

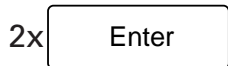

● Press **Enter**.

If the **Enter key** is pressed once, a move is made to the curve input (value 6), this value should remain unchanged (no curve).

To enter the hip depth **Enter** must be pressed again.



● Enter the hip depth.

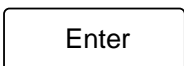

● Press **Enter**.

A move is made to the input for hip length (value 4)



● Enter hip length.



● Press **Enter**.

A move is made to the curve input (value 7)

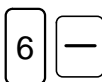

● Enter curve.

Input



- Press **Enter**.
A move is made to the point for entering the pleat depth at end (value 5).



- Enter pleat depth at end value.

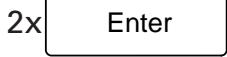

- Press **enter** twice.
The input is changed. (Value 9 remains unchanged).



- Press number key 8 until the symbol for **Stitch condensing seam start** appears on the display.

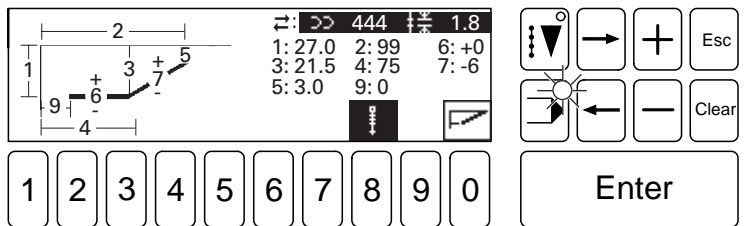

- Select **SEWING** mode, to end the seam program input.
The values are checked and the seam pattern calculated. If errors are detected, these are displayed with a relevant error message.

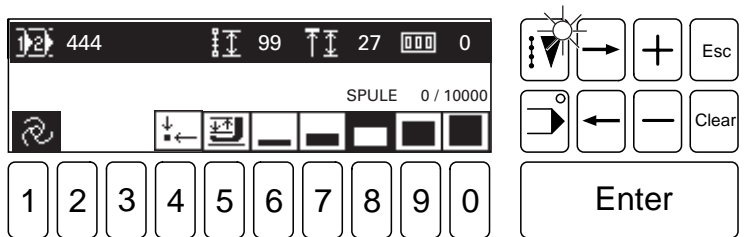

11.08 CREATE/MODIFY FREE PROGRAMS



With the **Create modify free programs** function seam programs can be processed directly on the machine using the graphics control panel.



A newly created or modified seam program must be carried out step by step on the machine first, to avoid any collisions!

11.08.01 Program structure

Each data record consists of three elements:

Program header

The purpose of this feature is to manage the programs and it contains details of the program number and the length of the program.

Geometrical data record

This consists of elements, so-called sections, which can be divided into two groups:

- Sections, which influence the geometry of the seam pattern
- Sections with machine functions

Stitch data record

This is necessary for the sewing operation and is generated from the geometrical data record by stitch generation. It consists of coordinate pairs and machine commands, and is concluded by the end-of-program command.

11.08.02 Entering the free programming function

It is only possible to enter this function when the machine is in its starting position.



- Switch on the machine and select **INPUT mode**.

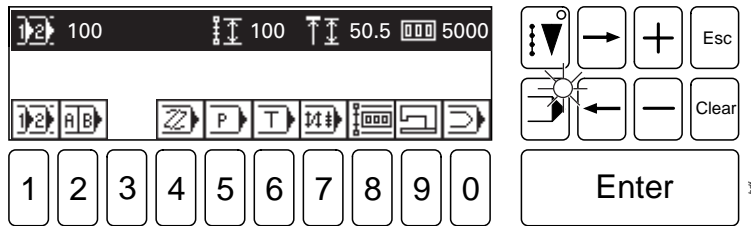

- Select the **program number selection** function (number key 1).



- Enter desired program number, e.g. 99.
The program group 0 - 99 is designated for free programming, but other program numbers (seam types) can be selected and modified.

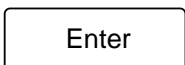

- Press **Enter**.

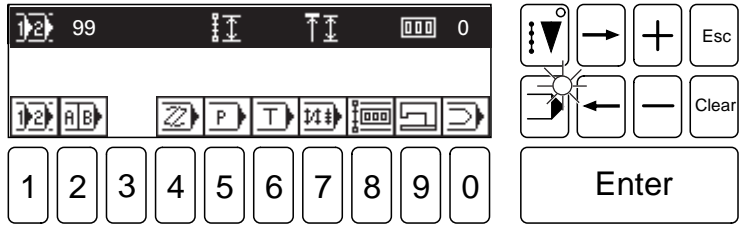

- Select the **create/modify free program** function (number key 6).
The operational mode changes automatically from INPUT to SEWING.

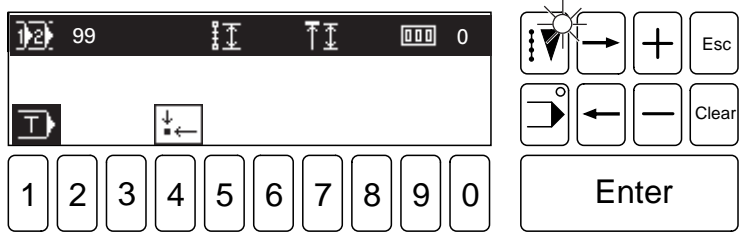

Explanation of the symbols in the pictogram bar:

-  **Create / modify free program**
A symbol displayed on a dark background indicates that you are in free programming. No function is allocated to the symbol.

-  **Starting position** (number key 4)
Direct function, to bring the machine into its starting position.

- Insert the workpiece and move the loading table forwards.

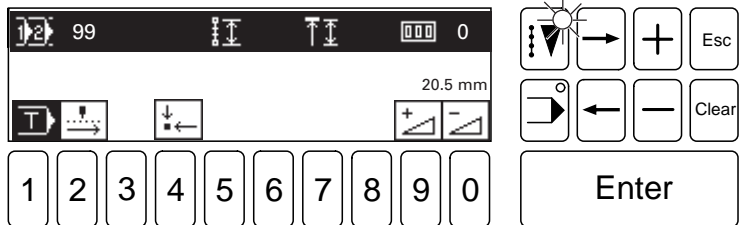



Explanation of the symbols in the pictogram bar:

-  **Create / modify free program**
A symbol displayed on a dark background indicates that you are in free programming. No function is allocated to the symbol.

-  **Move forward step by step** (number key 2)
This function moves through the sequence step by step.

-  **Starting position** (number key 4)
Direct function, to bring the machine into its starting position.

-   **Increase insertion depth** (number key 9) / **Reduce insertion depth** (number key 0).
This function is used to increase or reduce the insertion depth. The current value is displayed with the symbols.



- Move through the sequence step by step until the material take over takes over the workpiece.



- If necessary modify, e.g. reduce the insertion depth.
- Withdraw loading table.

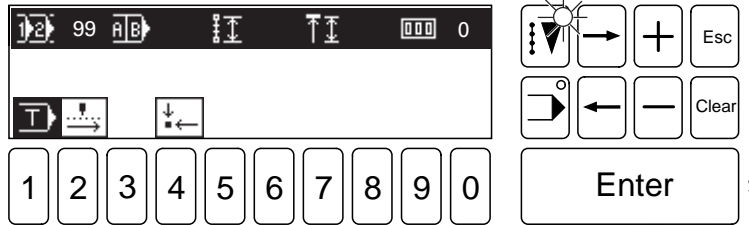

- Move through the sequence until reaching the initial state for free programming. As soon as the initial state has been reached, a change is made from the SEWING mode back into the INPUT mode, and the appropriate symbols appear on the display of the graphics control panel (initial state free programming).

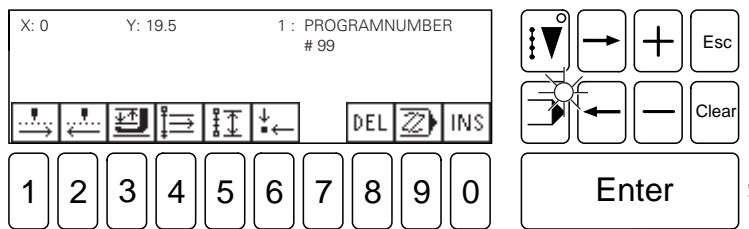

11.08.03 Status bar in initial state (free programming)

When entering seam programs, the status bar is displayed in the first line of the display.

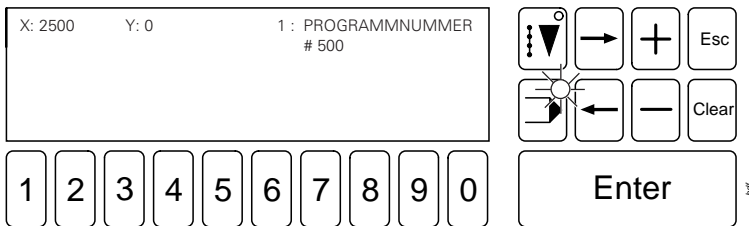







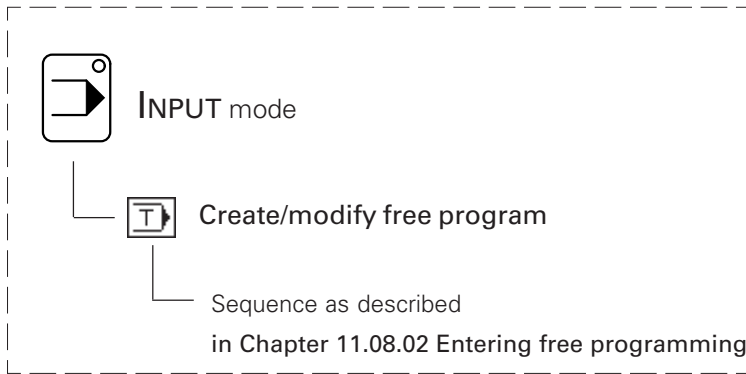

The status bar structure from left to right:

- X - axis coordinate
- Y - axis coordinate
- Section number with section type
 Section parameters belonging to the section type are shown below the section type.
 Sections within a marked block are shown by a symbol on a dark background

11.08.04 Summary of the functions in the initial state (free programming)



-  **Step - by - step forwards**
-  **Step - by - step backwards**
-  **Sewing foot up / down**
-  **Block functions**
 - 1 - MARK START OF BLOCK
 - 2 - MARK END OF BLOCK
 - 3 - MANIPULATE BLOCK
 - 1 - SCALE UP FACTOR FOR X - AXIS
 - 2 - SCALE UP FACTOR FOR Y - AXIS
 - 3 - ROTATION ANGLE
 - 4 - MIRROR
 - 4 - MOVE BLOCK
 - 5 - DELETE BLOCK
-  **Pattern functions**
 - 1 - MOVE PATTERN
 - 2 - MANIPULATE PATTERN
(SYMMETRY POINT WITH TRANSFER KEYS)
 - 1 - SCALE UP FACTOR FOR X - AXIS
 - 2 - SCALE UP FACTOR FOR Y - AXIS
 - 3 - ROTATION ANGLE
 - 4 - MIRROR
 - 3 - MANIPULATE PATTERN
(SYMMETRY POINT WITH NUMERIC KEYS)
 - 1 - SCALE UP FACTOR FOR X - AXIS
 - 2 - SCALE UP FACTOR FOR Y - AXIS
 - 3 - ROTATION ANGLE
 - 4 - MIRROR
-  **Reference point for coordinates**
-  **Delete**
-  **Modify**
-  **Activate insert**

(see Chapter 11.07.06 Summary of the functions ..)

11.08.05 Explanation of the functions in the initial state (free programming)

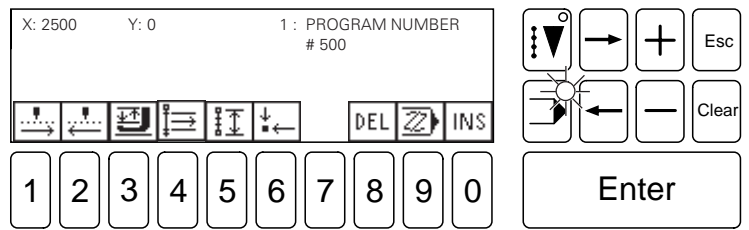

Step - by step forwards (Number key 1)

This functions allows you to trace the seam pattern step by step in a forward direction until the end of the program; by pressing **Enter** at the same time, the entire seam pattern is traced automatically.



Step - by - step backwards (Number key 2)

This functions allows you to trace the seam pattern step by step backwards until the program number is reached; by pressing **Enter** at the same time, the entire seam pattern is traced automatically.



Sewing foot up / down (Number key 3)

Allows you to raise and lower the sewing foot.



Block functions (Number key 4)



- 1 MARK START OF BLOCK/MARK END OF BLOCK
After a desired point in the program has been selected by tracing the seam pattern, the function MARK START OF BLOCK allows you to determine the start of a block. Marking the block must be completed by determining the end of the block. To do so, trace the pattern to the desired point and select the function
- 2 MARK END OF BLOCK. When tracing the seam pattern, the marked block can be identified by the section number and type, which are shown on a dark background.
- 3 MANIPULATE BLOCK
This function contains the sub-functions SCALE UP FACTOR FOR X - AXIS, SCALE UP FACTOR FOR Y - AXIS, ROTATION ANGLE and MIRROR. The functions can be carried out separately or at the same time. If the ROTATION ANGLE and MIRROR functions are carried out together, the block is first mirrored and then rotated.

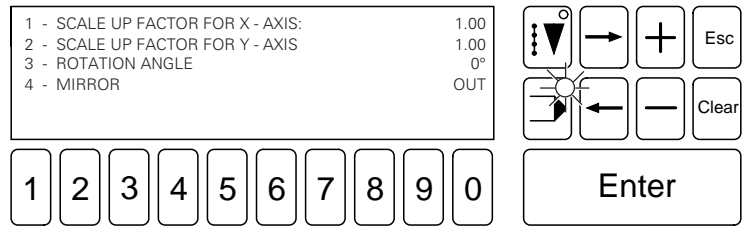

- 1 SCALE UP FACTOR FOR X - AXIS
This function is used to enlarge a block.
- 2 SCALE UP FACTOR FOR Y - AXIS
This function is used to reduce a block.
- 3 ROTATION ANGLE
This function is used to rotate a block.
The block is rotated anti-clockwise around the block starting point.
- 4 MIRROR
This function is used to mirror a block. The mirroring takes place on the straight lines running parallel to the Y - axis and through the block starting point.

- 4 MOVE BLOCK
After selecting the MOVE BLOCK function, the carriage drive must be moved to a new point. This point is taken over by pressing **Enter**, and the block is moved.

- 5 DELETE BLOCK
After selecting the function DELETE BLOCK, the block is deleted.



Pattern functions (number key 5)

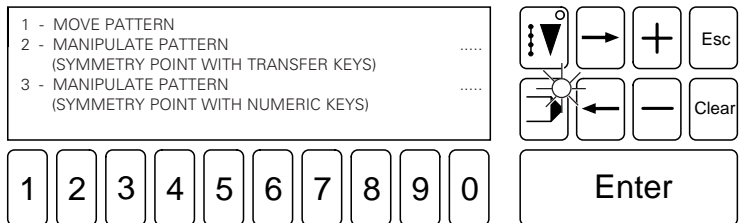

- 1 MOVE PATTERN
After selecting the MOVE PATTERN function, the carriage drive must be moved to a new point. The point is taken over by pressing **Enter**, and the pattern is moved from its current position to the end of the program.
- 2 MANIPULATE PATTERN
(SYMMETRY POINT WITH TRANSFER KEYS)
By pressing transfer keys, the symmetry point is located (entered).
- 3 MANIPULATE PATTERN
(SYMMETRY POINT WITH NUMERIC KEYS)
The symmetry point is determined by entering coordinates with the **number keys**. After the symmetry point has been entered, each of the functions SCALE UP FACTOR FOR X - AXIS, SCALE UP FACTOR FOR Y - AXIS, ROTATION ANGLE and MIRROR are available. For a description of the function compare MANIPULATE BLOCK. All the functions apply to the entire program.



Reference point for coordinates (number key 6)

With this function the coordinates in the display are set at 0, so that a new reference point is created.



Delete (number key 8)

This function deletes the current section.



Modify (number key 9)

After selecting this function, the current section can be modified.



Activate insert (number key 0)

This function is used to switch between the **Insert** and **Initial state** mode. When the function is switched off, **Initial state** is active.

11.08.06 Summary of the Insert functions



The **Activated Insert** function can only be selected in the initial state of free programming after the program header has been traced (see **Chapter 11.08.04 Summary of the functions in the initial state (free programming)**).

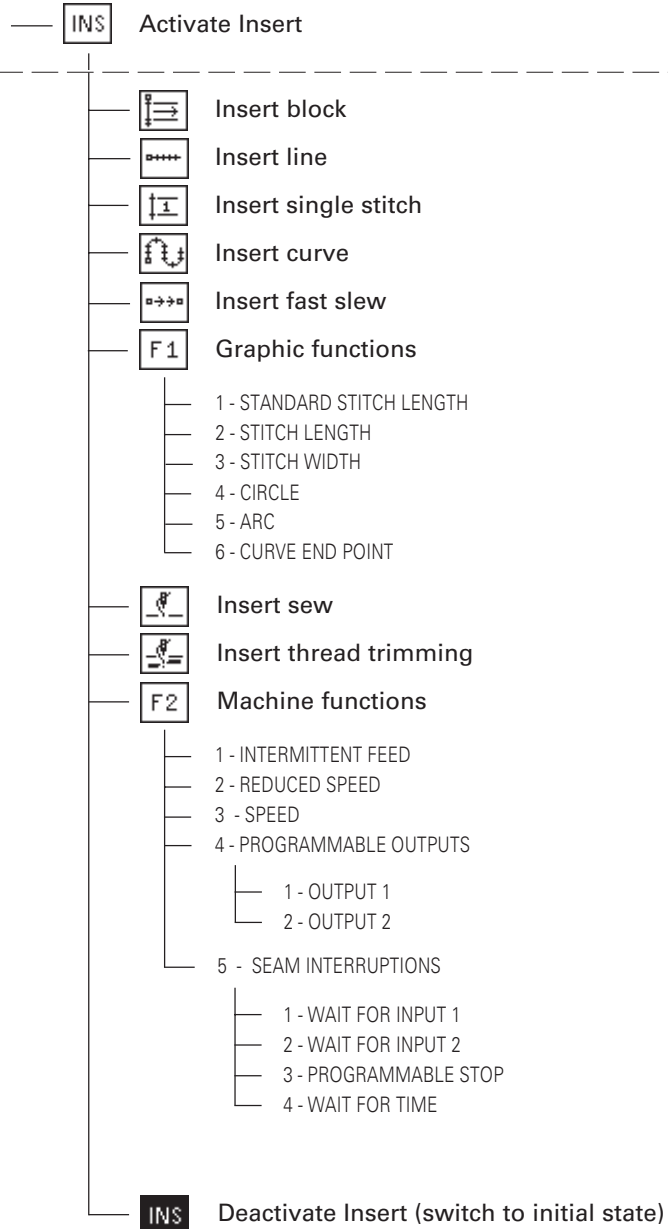

11.08.07 Explanation of the insert functions

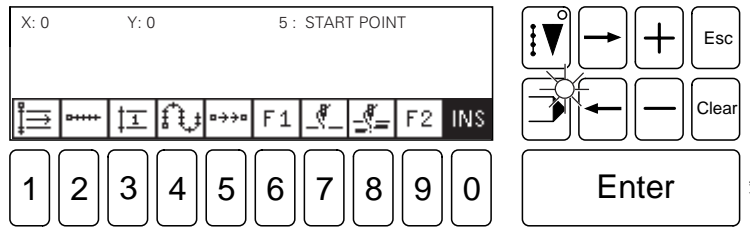

Block (number key 1)

A marked block is inserted from the current position forwards.



Line (number key 2)

A straight line is a direct connection between two points. To insert a straight line, a stitch length must be defined.



Single stitch (number key 3)

A single stitch or step forward is entered. No stitch length is taken into consideration. The single stitch or step forward can be max. 6 mm.



Curve (number key 4)

Any desired number of points can be entered on the curve. Taking the stitch length into consideration, the controller calculates the run of the curve. These points do not necessarily have to be penetration points. A stitch length must be defined. The greater the number of points inserted, the more exact is the run of the curve.



Fast slew (number key 5)

This serves the purpose of quickly moving the carriage drive. Both axes are moved independently from each other to the end point as quickly as possible. The resulting path travelled is therefore not a straight line. To travel an exact path, it is necessary to work with a straight line or curve without sewing.



Graphic functions F1 (number key 6)

Under function key F1 there are graphic functions, which can be displayed and selected via a menu.

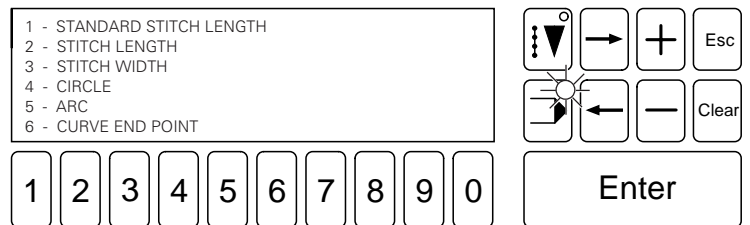

STANDARD STITCH LENGTH

With this function the stitch length, which is most often required in the program, is defined.

- 2

STITCH LENGTH
A stitch length is defined for a certain seam sector.
- 3

STITCH WIDTH
With this function the carriage drive carries out a zigzag movement on a base line. The stitch length specifies the movement along the base line from one penetration to the next and has to be selected accordingly. The stitch width is performed perpendicular to the base line. The position of the zigzag to the base line must also be defined. To switch off the stitch width, enter the width as 0.0.
- 4

CIRCLE
To enter a circle, 3 points are required. The first point is automatically the starting point. Both missing points must be entered. A stitch length must be defined.
- 5

ARC
For the arc the same applies as for the circle. The last point is the end of the arc.
- 6

CURVE END POINT
With this function a curve point is turned into a curve end point.



Start sewing (number key 7)

With this function sewing is started. All following sections are sewn until the thread trimming function is selected.



Thread trimming (number key 8)

The thread is cut. The sewing function must have been active beforehand.



Machine functions F2 (number key 9)

The machine functions are under this function. These can be displayed and selected via a menu. All machine functions are allocated an adjustment parameter, with which it is possible to move the function 99 stitches in front of or behind the current position.

1 - INTERMITTENT FEED 2 - REDUCED SPEED 3 - SPEED 4 - PROGRAMMABLE OUTPUTS 5 - SEAM INTERRUPTIONS	<table style="border-collapse: collapse; margin: auto;"> <tr> <td style="border: 1px solid black; padding: 5px;"></td> <td style="border: 1px solid black; padding: 5px;">→</td> <td style="border: 1px solid black; padding: 5px;">+</td> <td style="border: 1px solid black; padding: 5px;">Esc</td> </tr> <tr> <td style="border: 1px solid black; padding: 5px;"></td> <td style="border: 1px solid black; padding: 5px;">←</td> <td style="border: 1px solid black; padding: 5px;">-</td> <td style="border: 1px solid black; padding: 5px;">Clear</td> </tr> </table>		→	+	Esc		←	-	Clear			
	→	+	Esc									
	←	-	Clear									
<table style="border-collapse: collapse; margin: auto;"> <tr> <td style="border: 1px solid black; padding: 5px 10px;">1</td> <td style="border: 1px solid black; padding: 5px 10px;">2</td> <td style="border: 1px solid black; padding: 5px 10px;">3</td> <td style="border: 1px solid black; padding: 5px 10px;">4</td> <td style="border: 1px solid black; padding: 5px 10px;">5</td> <td style="border: 1px solid black; padding: 5px 10px;">6</td> <td style="border: 1px solid black; padding: 5px 10px;">7</td> <td style="border: 1px solid black; padding: 5px 10px;">8</td> <td style="border: 1px solid black; padding: 5px 10px;">9</td> <td style="border: 1px solid black; padding: 5px 10px;">0</td> </tr> </table>	1	2	3	4	5	6	7	8	9	0	<table style="border-collapse: collapse; margin: auto;"> <tr> <td style="border: 1px solid black; padding: 10px 20px;">Enter</td> </tr> </table>	Enter
1	2	3	4	5	6	7	8	9	0			
Enter												

- 1 INTERMITTENT FEED
It is possible to enter a sector, where the carriage feed is intermittent.
- 2 REDUCED SPEED
It is possible to enter a sector, where sewing takes place at a reduced speed. The reduced speed value is selected on the machine, see **Chapter 11.05 Functions in the INPUT mode.**
- 3 SPEED
A fixed speed is entered in the program.
- 4 PROGRAMMABLE OUTPUTS
Via a menu a choice of outputs can be selected.
 - 1 OUTPUT 1
 - 2 OUTPUT 2
- 5 SEAM INTERRUPTIONS
The program procedure is interrupted. If this function is selected, a menu is displayed, where the type of interruption can be selected.
 - 1 WAIT FOR INPUT 1
The program procedure is interrupted until the input has reached the appropriate level.
 - 2 WAIT FOR INPUT 2
 - 3 PROGRAMMED STOP
A stop has been programmed in the program.
 -  By calling up the **Start** function, the procedure is continued.
 - 4 WAIT FOR TIME
The program procedure is stopped until the programmed time has elapsed.



Deactivate Insert (number key 0)

This function is used for switching between **Insert** and **Initial state mode**.
When this function is switched on (symbol is shown on a dark background) **Insert** is activated.



The CREATE/MODIFY PROGRAM function can be ended at any time by activating the operational mode keys (**INPUT/SEW**)

11.08.08 An example for entering a free program

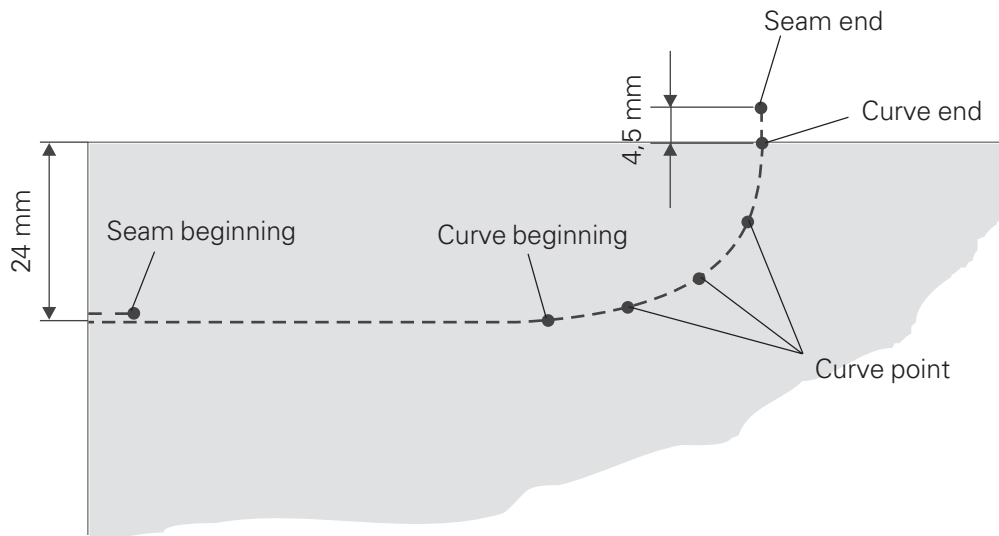

- Switch on the machine and select INPUT mode.

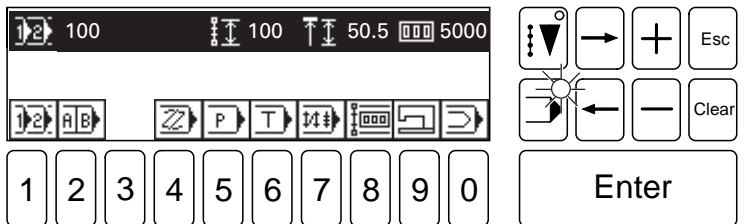

- Select Program number selection function (number key 1).

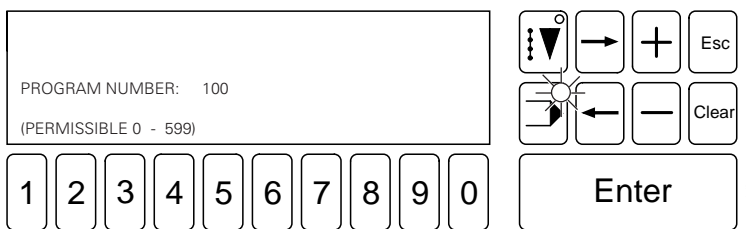

1

- Enter the desired program number with the **number keys** (e.g. 1 for creating a new seam program).

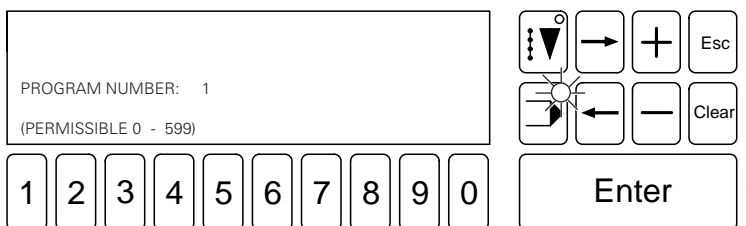

Enter

- Confirm input with **Enter**.

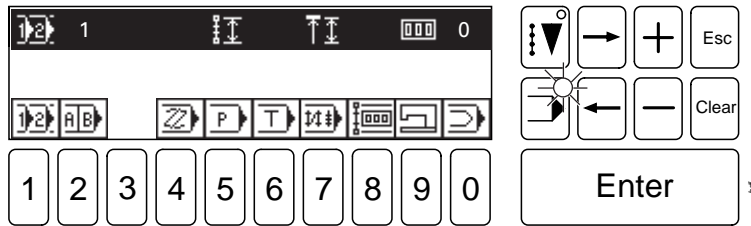

- Select **Create/modify free program** function (number key 6).
The operational mode changes automatically from INPUT to SEWING.

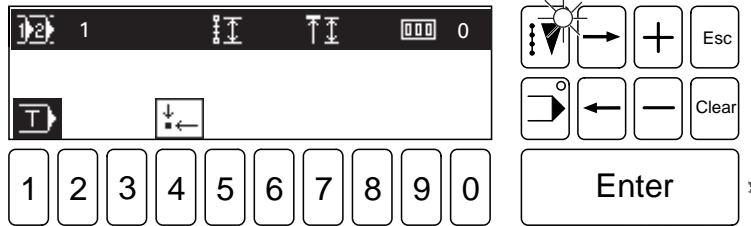

- Insert seam sample, push loading table forwards and select **Step - by step forwards** function (number key 2) to apply pressure to the loading table.

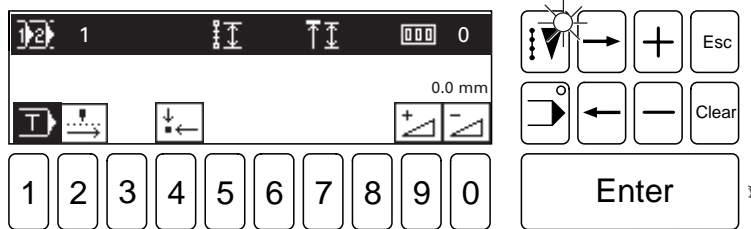

- Change insertion depth to **24 mm** (number key 9).



- Take over the insertion depth value by withdrawing the loading table.

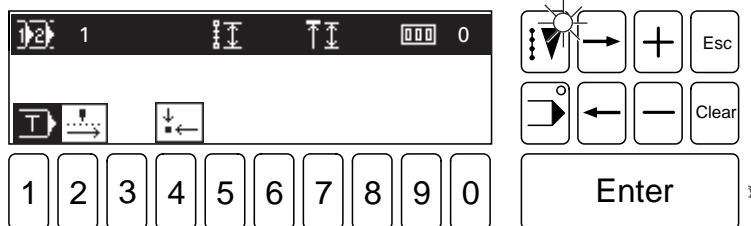

- Move through the sequence step by step until reaching the initial state for free programming.

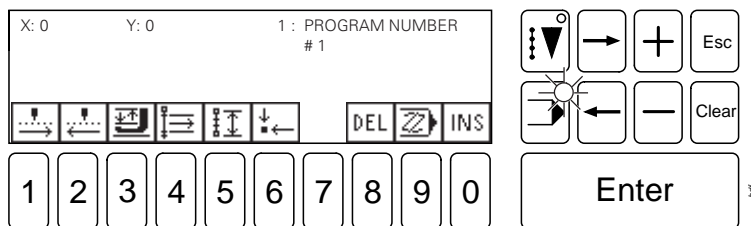

- Select **Step by step forwards** function (number key 1).

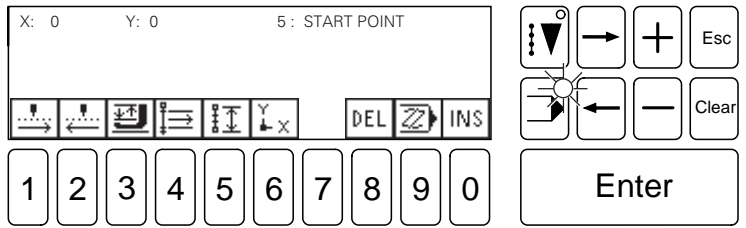

● Select **Modify** function (number key 9) to insert the start point.

● With **number keys 1 - 4** move to the start point and check this with the needle.



● Conclude insert with **Enter**.



● Press **Plus** key.

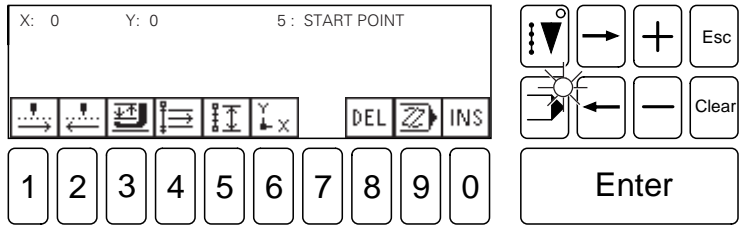

● Select **Switch on insert** function (number key 0).

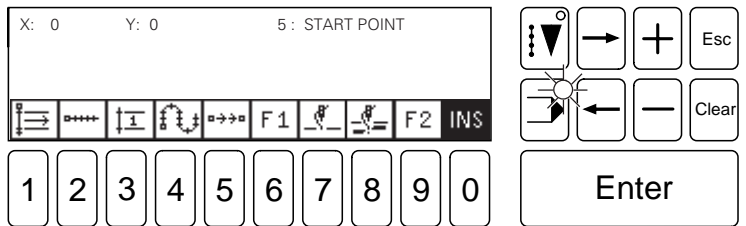

● Insert **Sewing** function (number key 7).

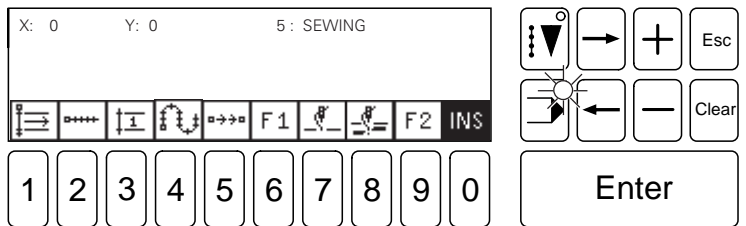

● Select **graphics functions** (number key 6).

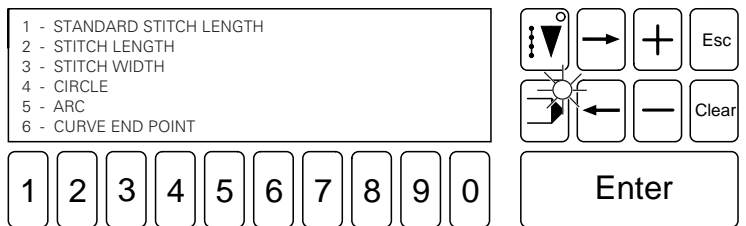

1

- Select STANDARD STITCH LENGTH function.

2 5 0

- Enter value for the standard stitch length (e.g. 2.50 mm) using the **number keys**.

Enter

- Confirm input with **Enter**.

- Select **Line** function (number key 2) to enter a straight line.

- Using the **number keys 1 - 4** move to the end of the straight line.

Enter

- Press **Enter** to confirm input.

- Using the **number keys 1 - 4** move to the next line end point.

Enter

- Press **Enter** to confirm input.

- INS** ● Switch off Insert function (number key 0) to move into initial state.

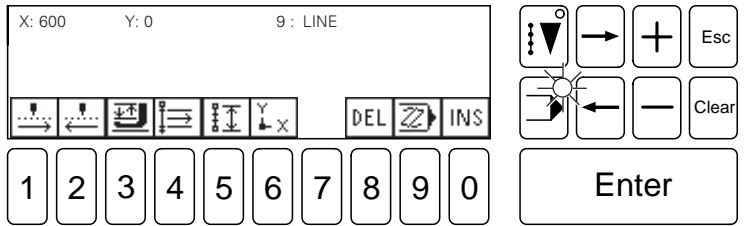

- INS** ● Select Insert function (number key 0)

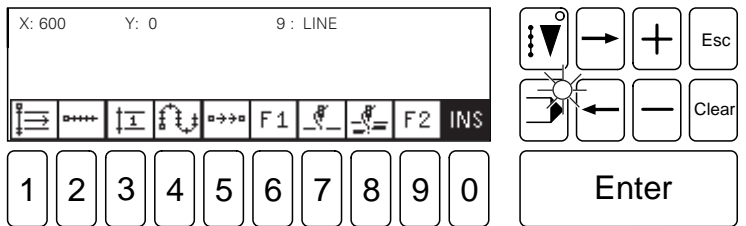

- Curve** ● Select Curve function (number key 4).

- Using the number keys 1-4 move to the first curve point.

- Enter** ● Press Enter to confirm input.

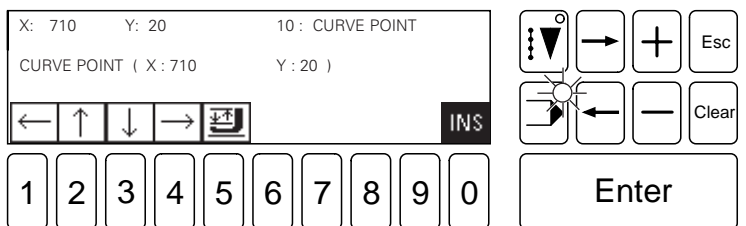

- Using the number keys 1 - 4 move to the second curve point.

- Enter** ● Press Enter to confirm input.

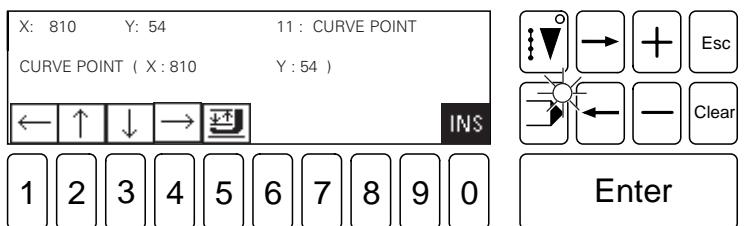

- Using the number keys 1 - 4 move to the third curve point

- Enter** ● Press Enter to confirm input.

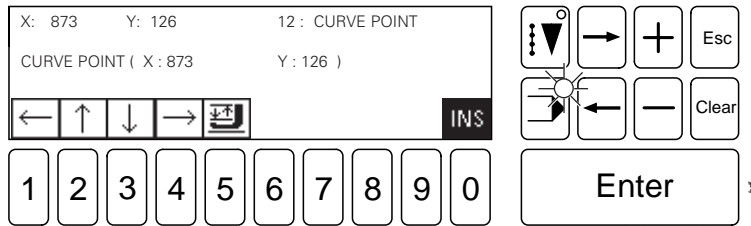

- Using the **number keys 1 - 4** move to the curve end point.



- Press **Enter** to confirm input.

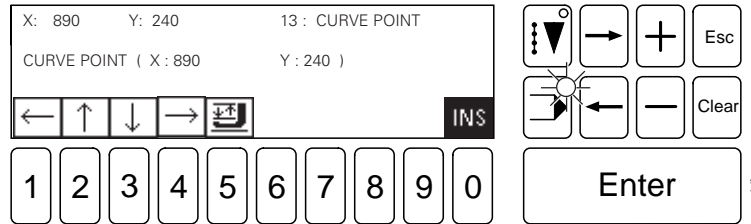

- By switching off the **Insert** function (number key 0) the curve end point is saved

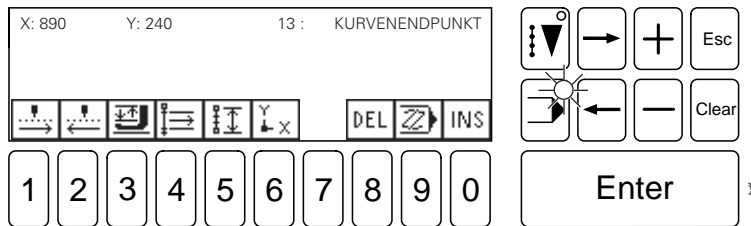

- Select **Insert** function (number key 0).



- Select **Line** function (number key 2).

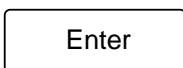

- Using the **number keys 1 - 4** move to the line end point and confirm with **Enter**.



- Switch off **Insert** function (number key 0)



- Select **Insert** function (number key 0)

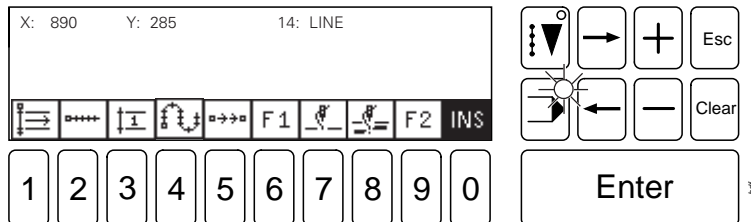

- Switch on **Thread trimming** (number key 8).



- Select **INPUT** mode to end seam programming input.
(The seam program is loaded in the machine memory.)



Go through a newly created or modified seam program step by step on the machine first, to avoid any collisions!

11.09 Installing operating programs

The booting of the software and firmware is menu-driven. When required the software triggers off the booting of the firmware.

Disks required:

- KL3586BOOT1 (machine software)
- KL3586BOOT2 (firmware, ramp)

11.09.01 Booting for software updates



- Switch on the machine and select INPUT mode.



- Select **Input menu** function.



- Select SERVICE function.



- Select OTHER FUNCTIONS function.



- Select INSTALLING OPERATING PROGRAMS function.



- Insert "KL3586BOOT1" disk into the disk drive and press the **Plus key**.
(Following display appears after a few seconds.)

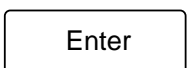
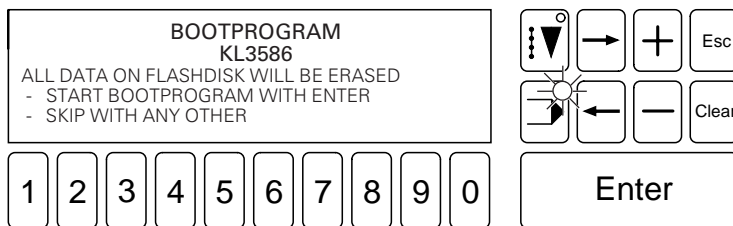

- Press **Enter** to start the Boot program. Press any other key on the control panel to interrupt the Booting procedure.

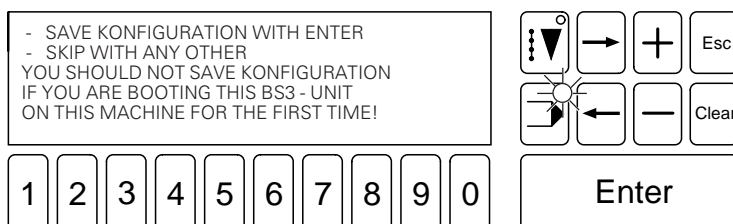

Enter

- Press **Enter** to save the configuration data and continue the booting procedure (e.g. for a software update).
Press any other key on the control panel to delete the configuration data (e.g. when replacing a BS3).

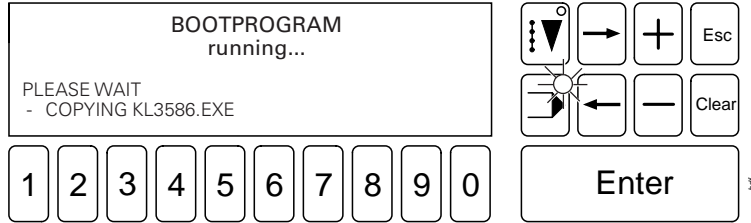

During the booting procedure the data being currently booted is displayed.

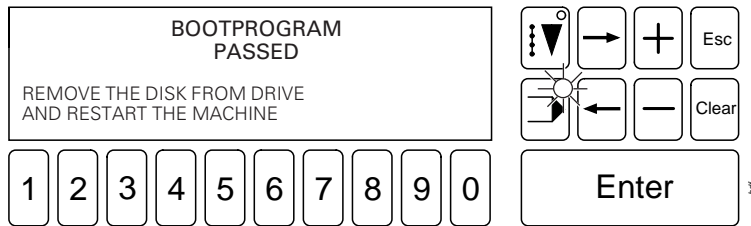

- After concluding the booting procedure the disk must be removed from the disk drive and the machine switched off and on again with the on/off switch.
- If, after the firmware has been checked automatically by the software, the firmware has to be booted, a command appears to enter the disk "KI3586BOOT2".

11.09.02 Booting after changing the basic control unit



- Switch off the machine and open the control cabinet.
- Insert the disk "KI3586BOOT1" in the disk drive.
- Switch on the machine and press the boot key **1** within the next 10 seconds (accessible through hole).
- After the boot display appears on the display screen, the procedure continues as in **Chapter 11.09.01 Booting for software updates**.

	Contents	Chapter - Page
12	Care and maintenance	12 - 1
12.01	Cleaning the machine	12 - 1
12.02	Cleaning the hook compartment	12 - 2
12.03	Cleaning the fan air filter	12 - 3
12.04	Cleaning the air filter of the air-filter/lubricator	12 - 3
12.05	Checking/adjusting the air pressure	12 - 4
12.06	Topping up the oil tank	12 - 5
12.07	Lubricating the feed guide units	12 - 6
13	Adjustment	13 - 1
13.01	Notes on adjusting	13 - 1
13.02	Tools, gauges and other accessories	13 - 1
13.03	Abbreviations	13 - 1
13.04	Tilting the sewing head	13 - 2
13.05	Adjustment aids	13 - 3
13.06	Adjusting the sewing head	13 - 4
13.06.01	Basic position of the machine drive	13 - 4
13.06.03	Hook shaft bearing and backlash	13 - 6
13.06.04	Hook lubrication	13 - 7
13.06.05	Needle rise, hook-to-needle clearance, needle height and bobbin case position finger	13 - 8
13.06.06	Thread check spring and slack thread regulator	13 - 9
13.06.07	Bobbin winder	13 - 10
13.07	Adjusting the thread trimming device	13 - 11
13.07.01	Preliminary adjustment of the control cam	13 - 11
13.07.02	Adjusting the roller lever	13 - 12
13.07.03	Lateral adjustment of the thread catcher	13 - 13
13.07.04	Knife position	13 - 14
13.07.05	Front point of reversal of the thread catcher	13 - 15
13.07.06	Manual trimming check	13 - 16
13.07.07	Readjusting the control cam	13 - 17
13.08	Adjusting the feed mechanisms	13 - 18
13.08.01	Aligning the fabric pressure bar	13 - 18
13.08.02	Aligning the drive unit of the X-axis	13 - 19
13.08.03	Tensioning the belt on the drive unit of the X-axis	13 - 20
13.08.04	Stop on drive unit of the Y-axis	13 - 21
13.08.05	Tooth flank play on the drive unit of the Y-axis	13 - 22
13.08.06	Zero points of the drive units of the X and Y axes	13 - 23
13.08.07	Zero point of the material take-over unit	13 - 25
13.08.08	Needle height of the material take-over unit	13 - 26
13.08.09	Adjusting the loading table	13 - 27
13.08.11	Correcting the start point	13 - 28
13.08.12	Adjusting the presser foot	13 - 29

12 Care and maintenance

Clean the entire machine	once a week
Clean the hook compartment	several times a day
Clean the needle area	several times a day
Clean the fan air filter	as required
Clean air filter of air filter/lubricator	as required
Check the air pressure	daily, before use
Check the oil level	every 6 months
Lubricate feed units	every 6 months



These maintenance intervals are calculated for the average running time of a single shift operation. If the machine is operated for longer periods, shorter maintenance intervals are recommended.

12.01 Cleaning the machine

The cleaning cycle required for the machine depends on following factors:

- Single or several shift operation
- Amount of dust resulting from the workpiece

It is therefore only possible to stipulate the best possible cleaning instructions for each individual case.



For all cleaning work the machine must be connected from the mains by switching off the on/off switch or by removing the mains plug.



To avoid breakdowns, the following cleaning work is recommended for single shift operation:

- Clean hook compartment and needle area of sewing head several times daily.
- Clean the entire machine at least once a week.

12.02 Cleaning the hook compartment

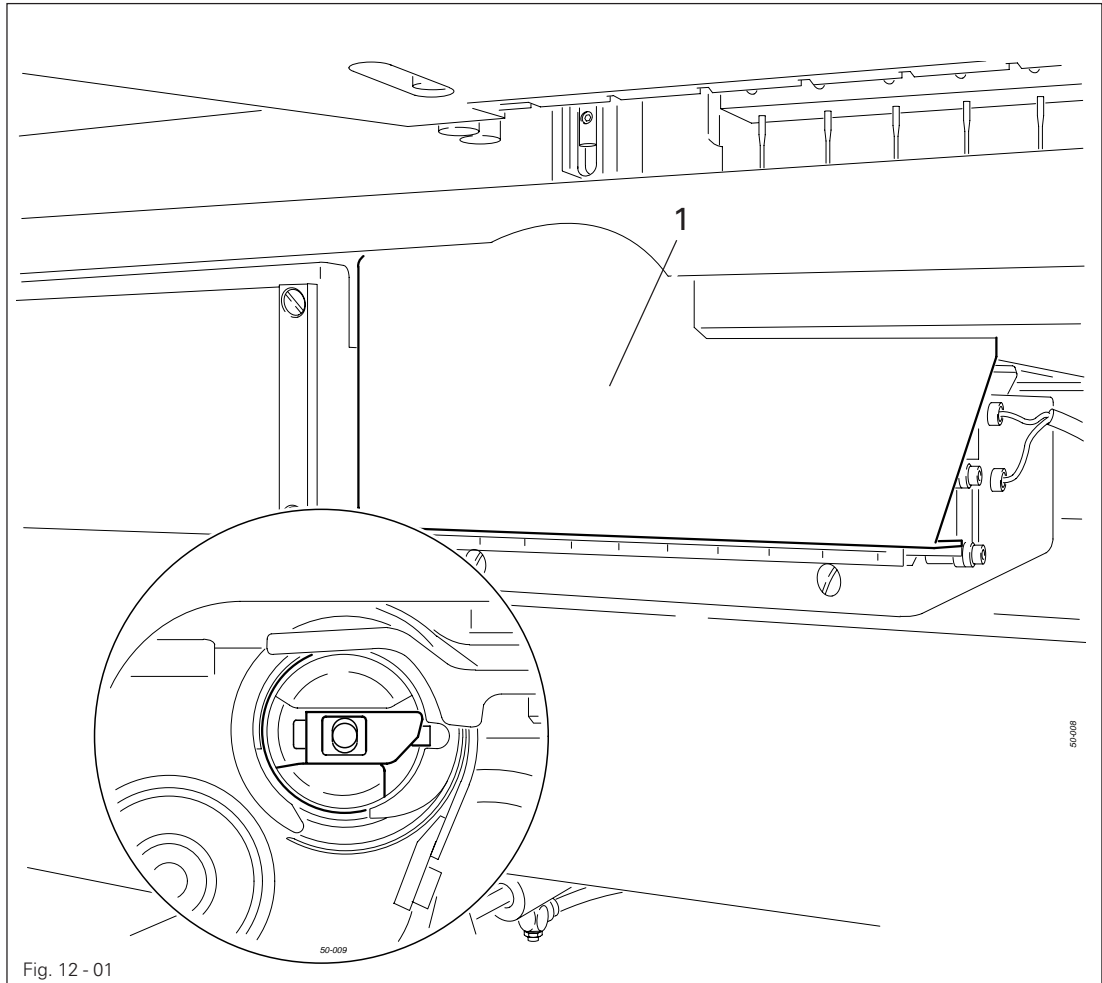

Switch off the machine!

Danger of injury if the machine suddenly starts running!

- Open hook compartment cover 1.
- Clean the hook and hook compartment daily, more often if in continuous use.

12.03 Cleaning the fan air filter

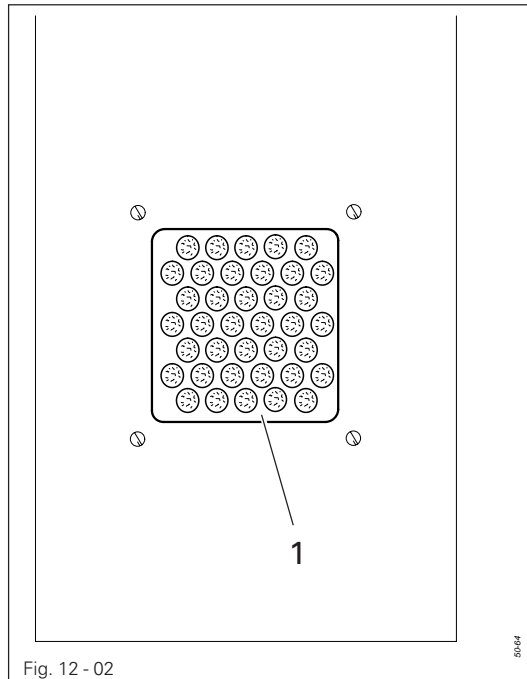

Fig. 12 - 02

5064

- Remove cover 1.
- Remove the filter unit and blast clean with compressed air.
- Insert the clean filter unit and replace cover 1.

12.04 Cleaning the air filter of the air-filter/lubricator

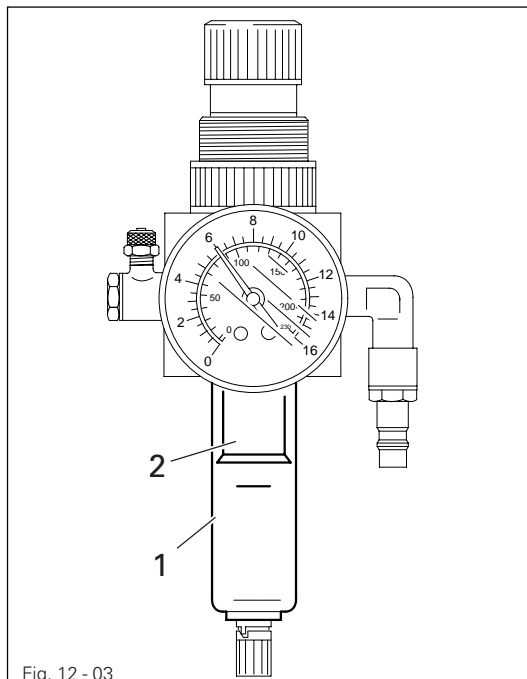

Fig. 12 - 03



Switch the machine off!
Disconnect the air hose at the air-filter/lubricator.

To drain water bowl 1:

- Water bowl 1 drains itself automatically when the compressed-air hose is disconnected from the air-filter/lubricator.

Cleaning filter 2:

- Unscrew water bowl 1.
- Take out filter 2.
- Clean filter 2 with compressed air or isopropyl alcohol (part No. 95-665 735-91).
- Screw in filter 2 and screw on water bowl 1.

12.05 Checking/adjusting the air pressure

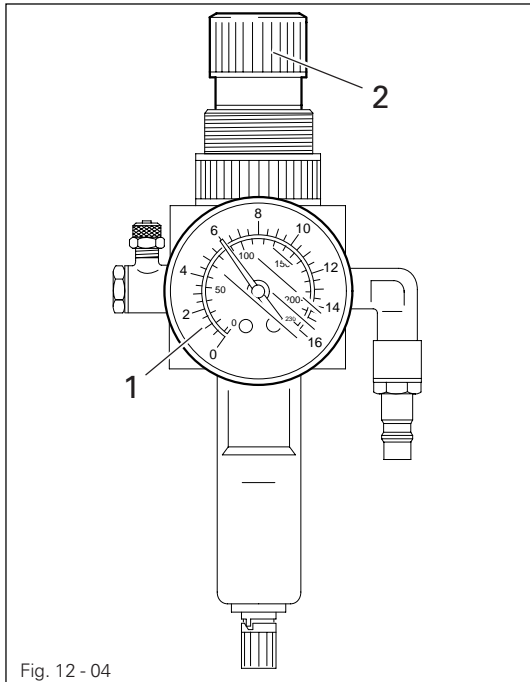

Fig. 12 - 04

- Before operating the machine, always check the air pressure on gauge 1.
- Gauge 1 must show a pressure of **6 bar**.
- If necessary adjust to this reading.
- To do so, pull knob 2 upwards and turn it so that the gauge shows a pressure of **6 bar**.

12.06 Topping up the oil tank

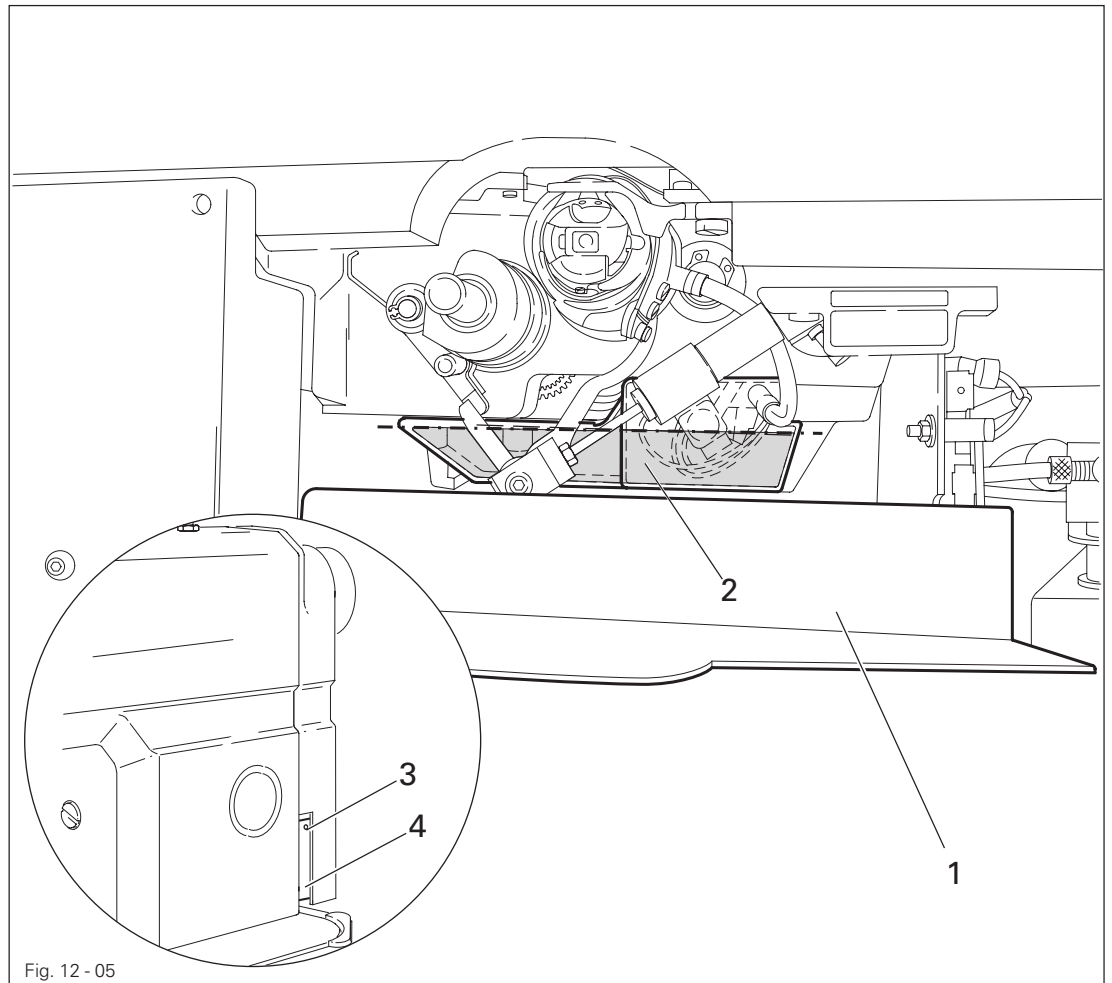

Fig. 12 - 05



Switch off the machine!
Danger of injury if the machine suddenly starts running!

- Open hook compartment cover 1.



The oil reservoir must always have oil in it.

- When required, fill oil into the tank 2 through hole 3 (fill max. up to line).



The oil tank 4 is not used as an oil level indicator, but only for filling tank 2.



Only use oil with a mean viscosity of 10.0 mm²/s at 40°C and a density of 0.847 g/cm³ at 15°C.

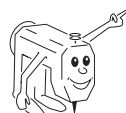

We recommend PFAFF sewing machine oil, part no. 280-1-120 105.

12.07 Lubricating the feed guide units

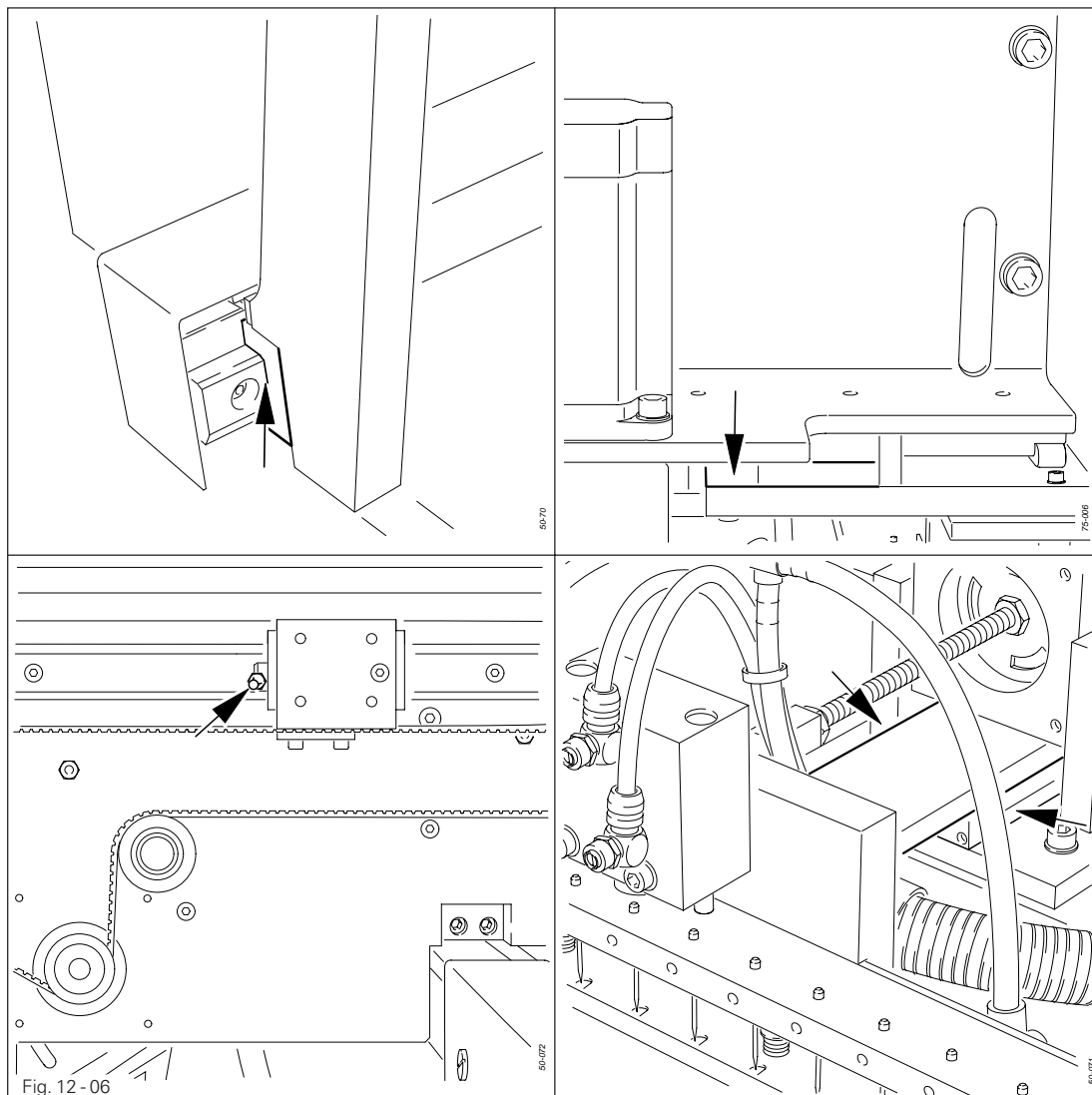

Switch off the machine and take measures to prevent it being switched on again!



Only use Isoflex Topas L32 high-performance grease, part no. 280-1-120 210.



- Unscrew the cover of the X-feed.
- With the appropriate lubricating nipple, using a grease gun, lubricate the guide units every 6 months for single shift operation, and once a month for double shift operation.
- Screw cover of the X-feed back on.

13 Adjustment



On the PFAFF 3586-2/02 do not use a screw clamp on the needle bar! The special coating of the needle bar could be damaged.

13.01 Notes on adjusting

All adjustments in these adjustment instructions are based on a completely installed machine and must only be carried out by appropriately trained specialists. Covers on the machine which sometimes have to be removed and replaced for checks and adjustment work are not mentioned here. The screws and nuts in brackets () are attachments of machine parts which are to be loosened before making the adjustment and tightened again after the adjustment has been carried out.

13.02 Tools, gauges and other accessories

- 1 set of screwdrivers with blade widths from 2 to 10 mm
- 1 set of wrenches with jaw widths from 7 to 14 mm
- 1 set of Allan keys from 1.5 to 6 mm
- 1 metal ruler, part no. 08-880 218-00
- 1 adjustment gauge, part no. 95-752 474-05
- 1 adjustment gauge for zero point adjustment, 95-779 096-05
- 1 adjustment pin for zero point adjustment, 95 779 095-05
- 1 measuring instrument for the belt tension Part No. 99-137 380-91
- 1 adjustment gauge for tightening the hook drive belt, Part-No. 61-111 639-76

13.03 Abbreviations

t.d.c. = top dead centre

b.d.c. = bottom dead centre

13.04 Tilting the sewing head



Turn off the compressed air!
Switch off the machine and take measures to prevent it being switched on again!

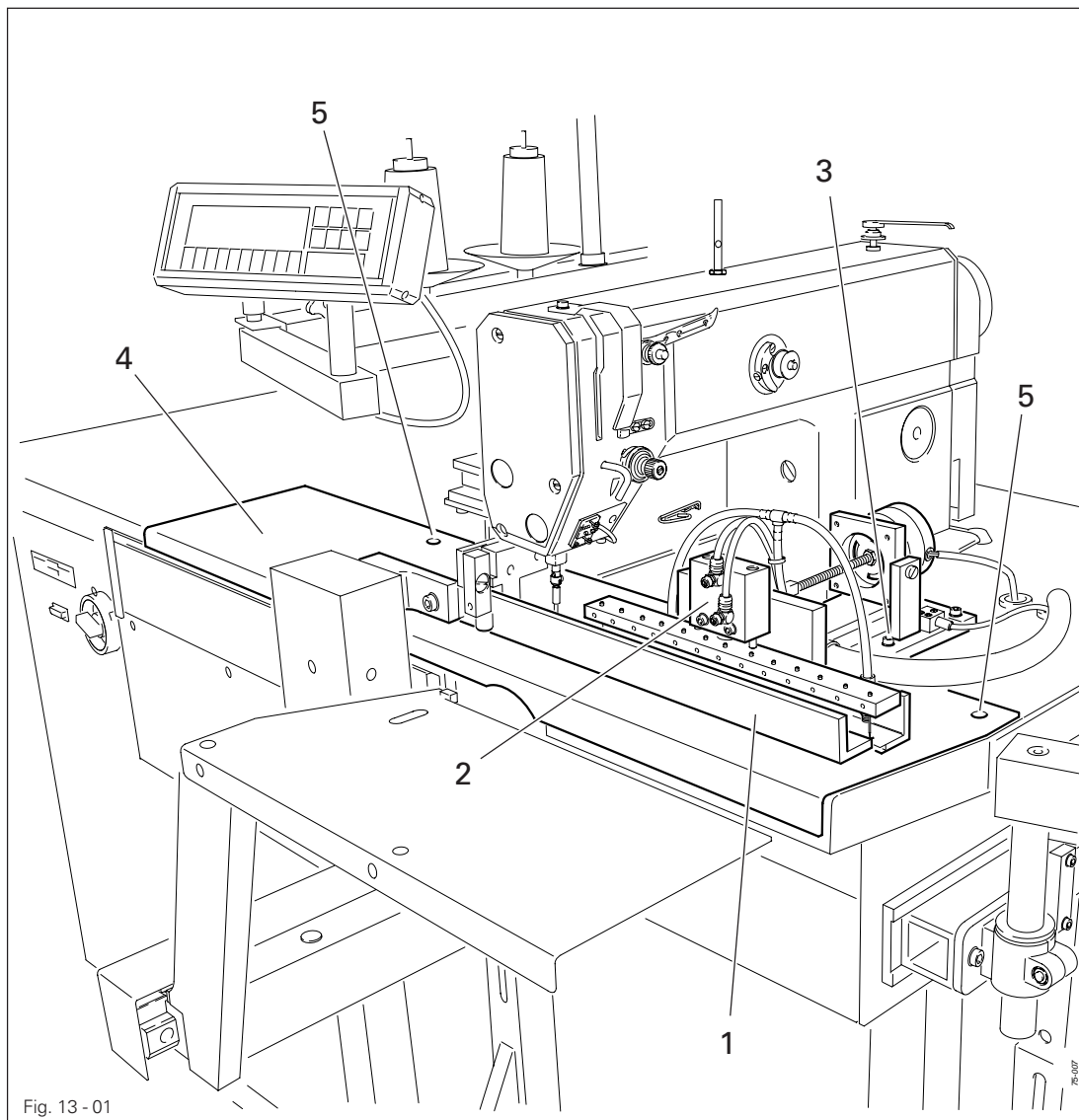
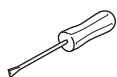

Fig. 13 - 01



- Slide pressure bar 1 to the left and tilt down.
- Tilt back material take-over unit 2 (screws 3, two screws in total).
- Slide cover plate 4 (screws 5) to the left.
- Tilt back sewing head.
- To reassemble, carry out the above procedure in the reverse order.

13.05 Adjustment aids



With the help of adjustment gauge 1 (part no. 95-752 474-05) the needle bar can be fixed in the needle rise position (needle bar position 1.8 mm below b.d.c.)

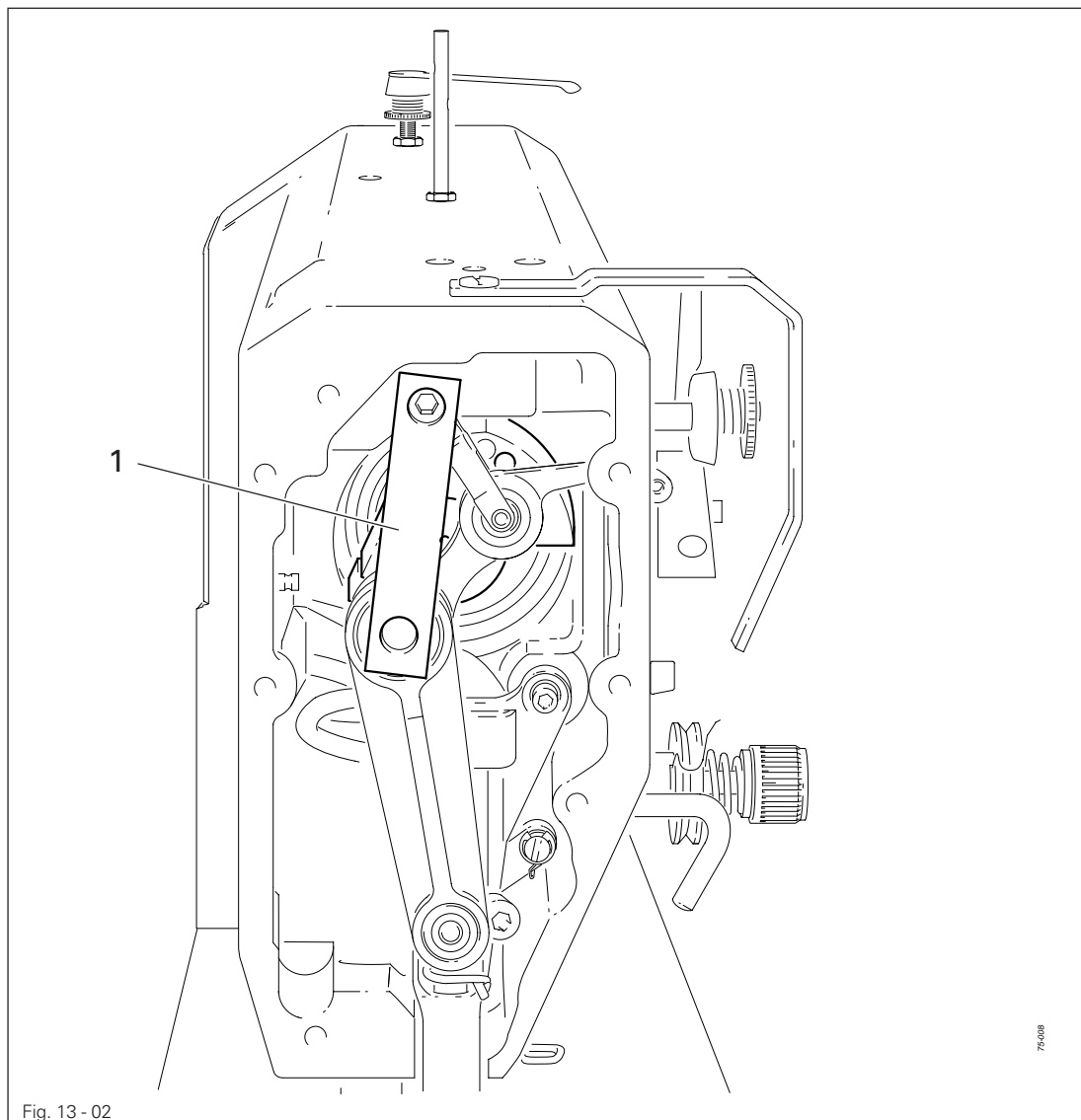
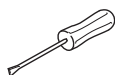

Fig. 13 - 02



- Turn the balance wheel until the needle bar is approximately in the required position.
- Fit adjustment gauge 1 as shown in Fig. 13-02. If necessary, turn the balance wheel a fraction backwards and forwards, until the adjustment gauge fits properly.

13.06 Adjusting the sewing head

13.06.01 Basic position of the machine drive



This adjustment is only required if toothed belt 2 has been removed.

Requirement

When the needle bar is positioned 1.8 mm past b.d.c., the markings 3 and 4 should be in alignment.

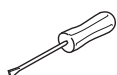
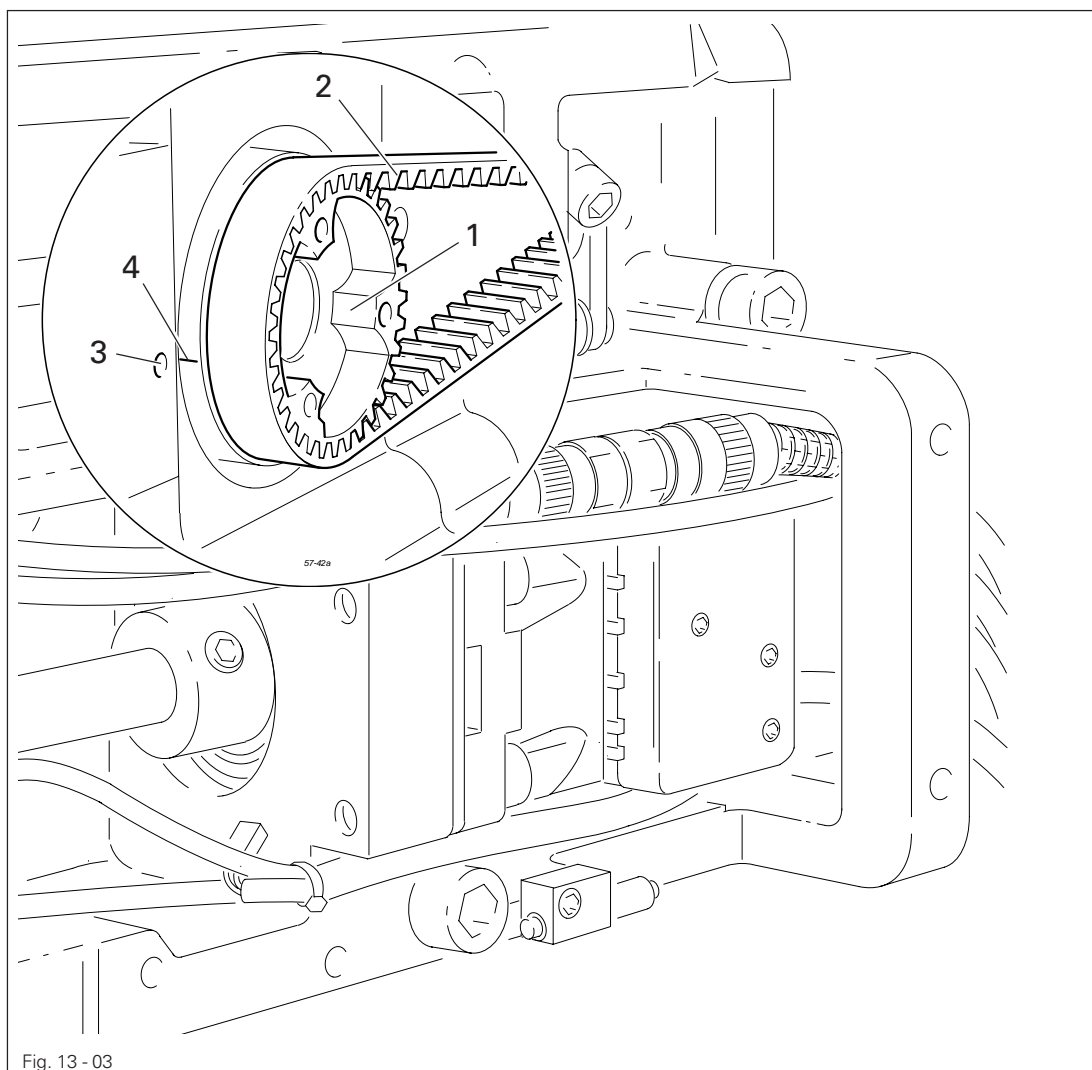

- Set needle bar at 1.8 mm past b.d.c. (see **Chapter 13.05 Adjustment aids**).
- Turn toothed belt sprocket 1 according to **Requirement** and push on toothed belt 2.



When installing the motor pay attention to the correct position of shaft flange, shock absorber and motor flange!

13.06.02 Needle in needle hole centre

Requirement

The needle should enter exactly in the centre of the needle hole.

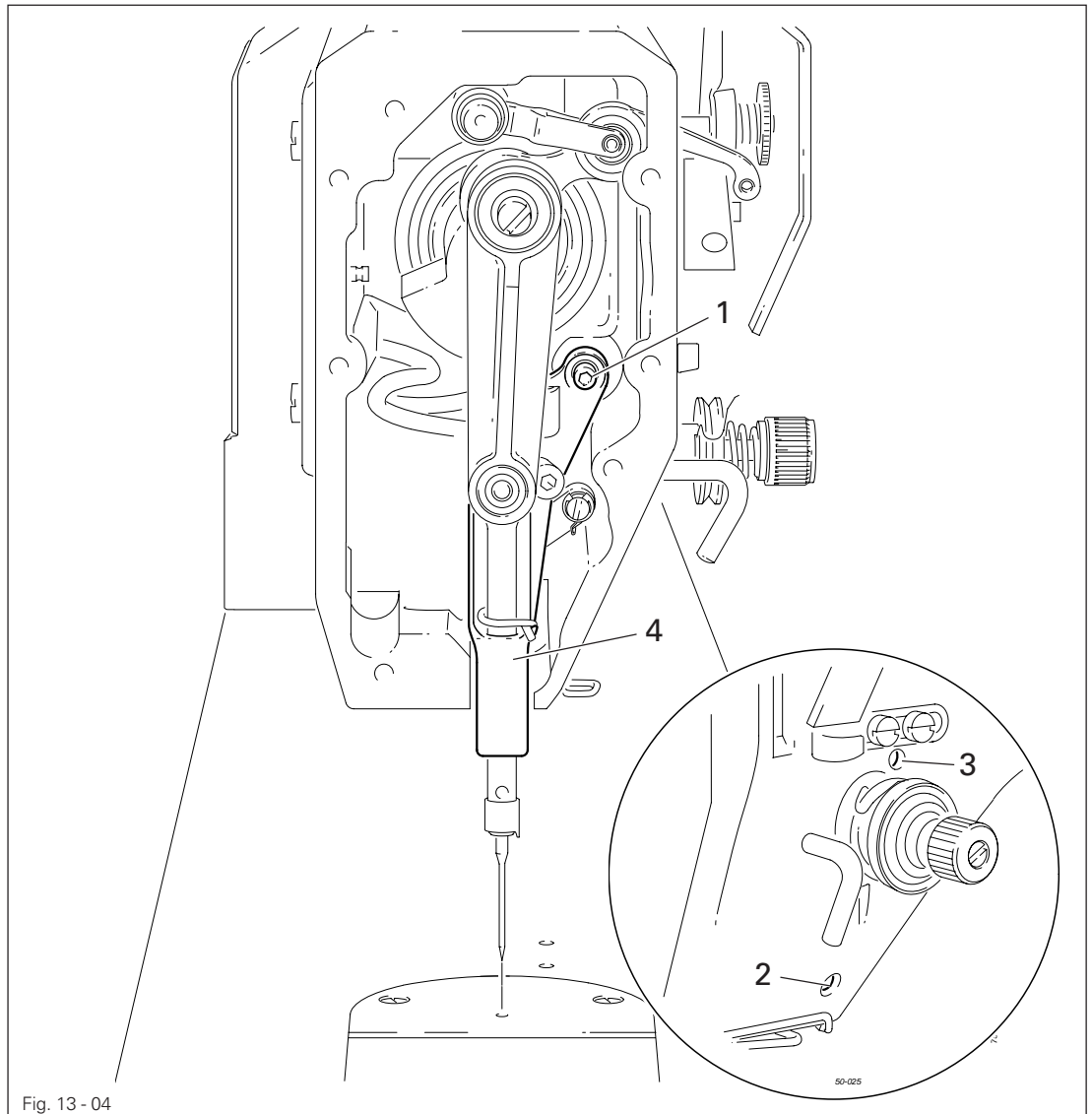
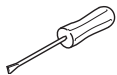

Fig. 13 - 04



- Position the needle directly above the needle hole.
- Loosen screws **1**, **2** and **3**.
- Adjust needle bar frame **4** according to the **requirement**.
- Tighten screw **2** and slightly tighten screw **3**.
- With screw **1** draw the inner guide stud towards the eye of the needle bar frame **4** and tighten it.
- Turn the balance wheel a few times, so that the needle bar frame **4** is not under tension.
- Tighten screw **3**.

13.06.03 Hook shaft bearing and toothed belt tension

Requirement

1. The front edge of the hook shaft **6** must be at a distance of **14.5 mm** to the needle center. At the same time, the slot in the hook shaft bearing **1** (see arrow) must be parallel to the bedplate and pointing opposite to the direction of sewing.
2. The toothed belt should be tightened in such a way that, when the gauge is pushed onto the toothed belt, the marking in the gauge window corresponds to the marking on the bushing.

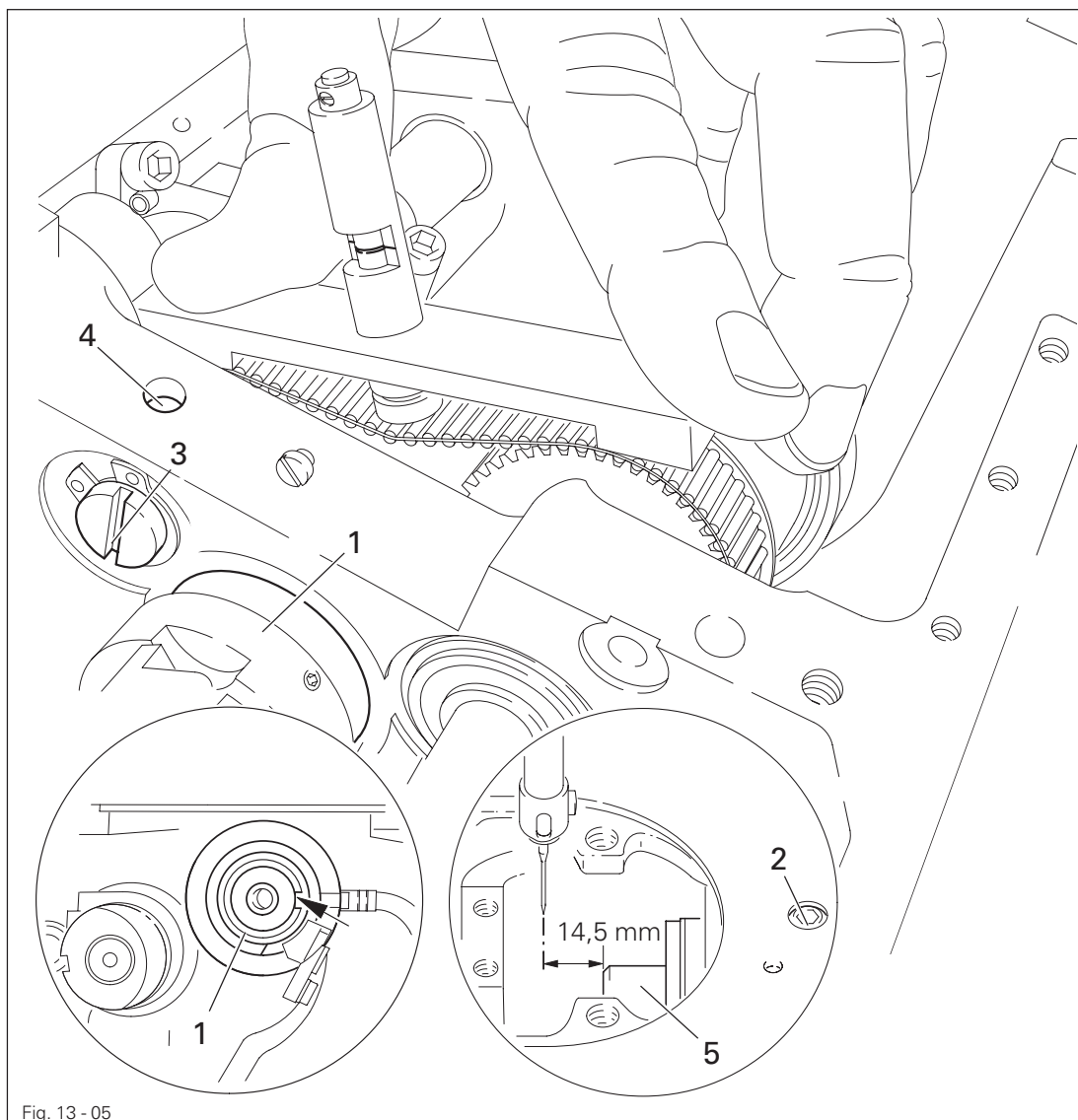
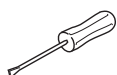

Fig. 13 - 05



- Align hook shaft bearing **1** (screw **2**) according to **requirement 1**.
- Push the gauge (Part-No. 61-111 639-76) onto the toothed belt so that it is centred to the toothed belt and touching the bearing of the sliding shaft. The gauge window must be facing the hook.
- Eccentric **3** (screw **4**) clockwise in accordance with **requirement 2**, taking care that the axial position of eccentric **3** is not altered.

13.06.04 Hook lubrication

Requirement

1. The centrifugal disk 1 must be positioned **1.5 mm** in front of the oil ring 3.
2. When the machine is running at full speed, **after approx. 10 seconds** a mark should be made by a fine stripe of oil on the strip of paper placed over the needle plate cutout.

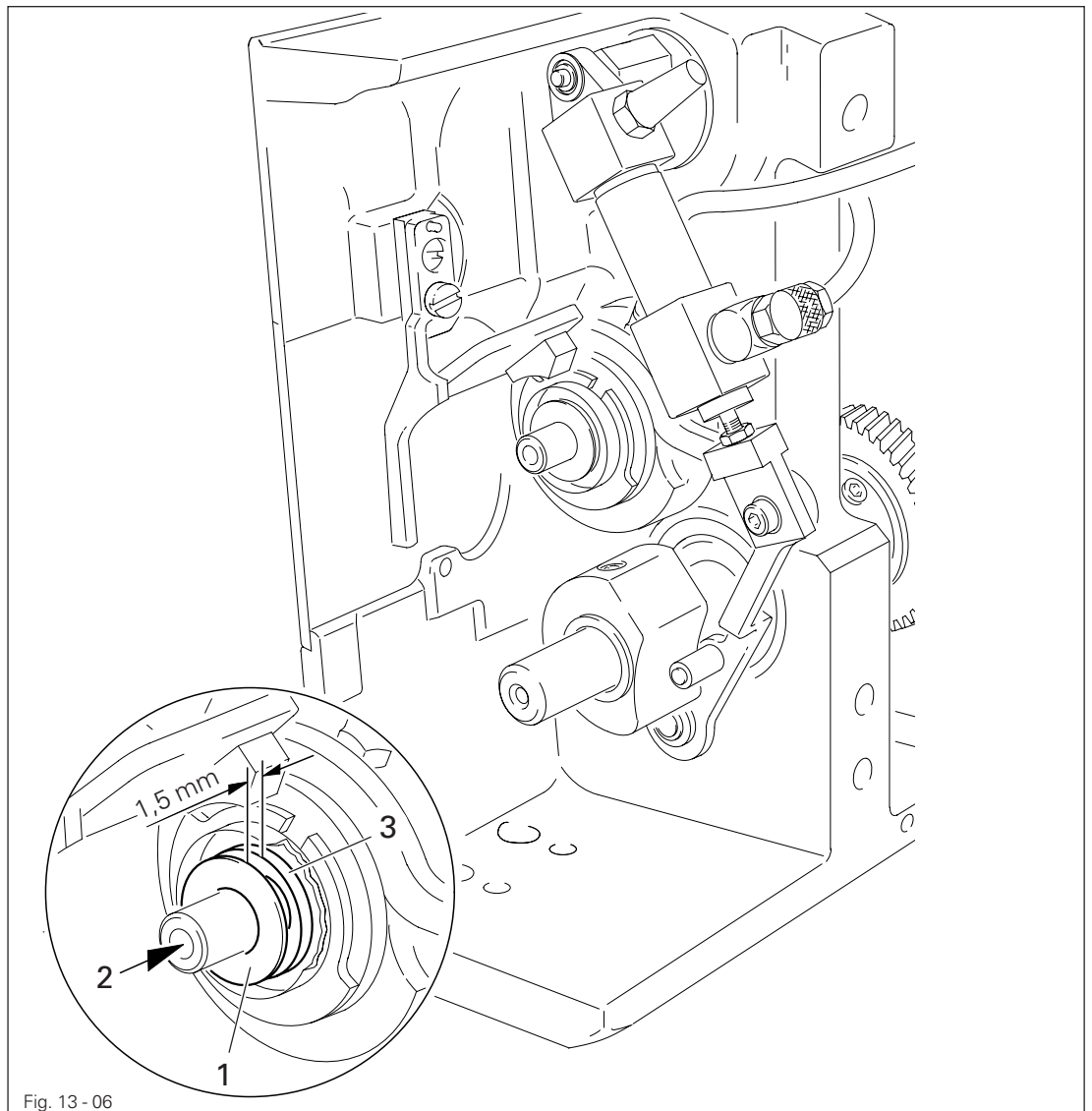

The adjustment is only necessary if the wick has been replaced.
When replacing the wick, make sure that the new wick is impregnated with oil.

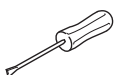

- Move the centrifugal disk 1 (screw 2) according to **requirement 1**.
- Check **requirement 2**. If necessary, move centrifugal disk 1.

13.06.05 Needle rise, hook-to-needle clearance, needle height and bobbin case position finger

Requirement

With the needle at 1.8 mm after BDC,

1. the hook point **6** must point to the middle of the needle and be at a distance of **0.05 mm - 0.1 mm** to the clearance cut of the needle, and
2. the top edge of the needle eye must be **0.8 mm** below the hook point.
3. Between the projection of the bobbin case position finger **4** and the bottom of the retaining groove there should be a distance of **0.5 mm**.

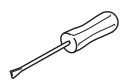
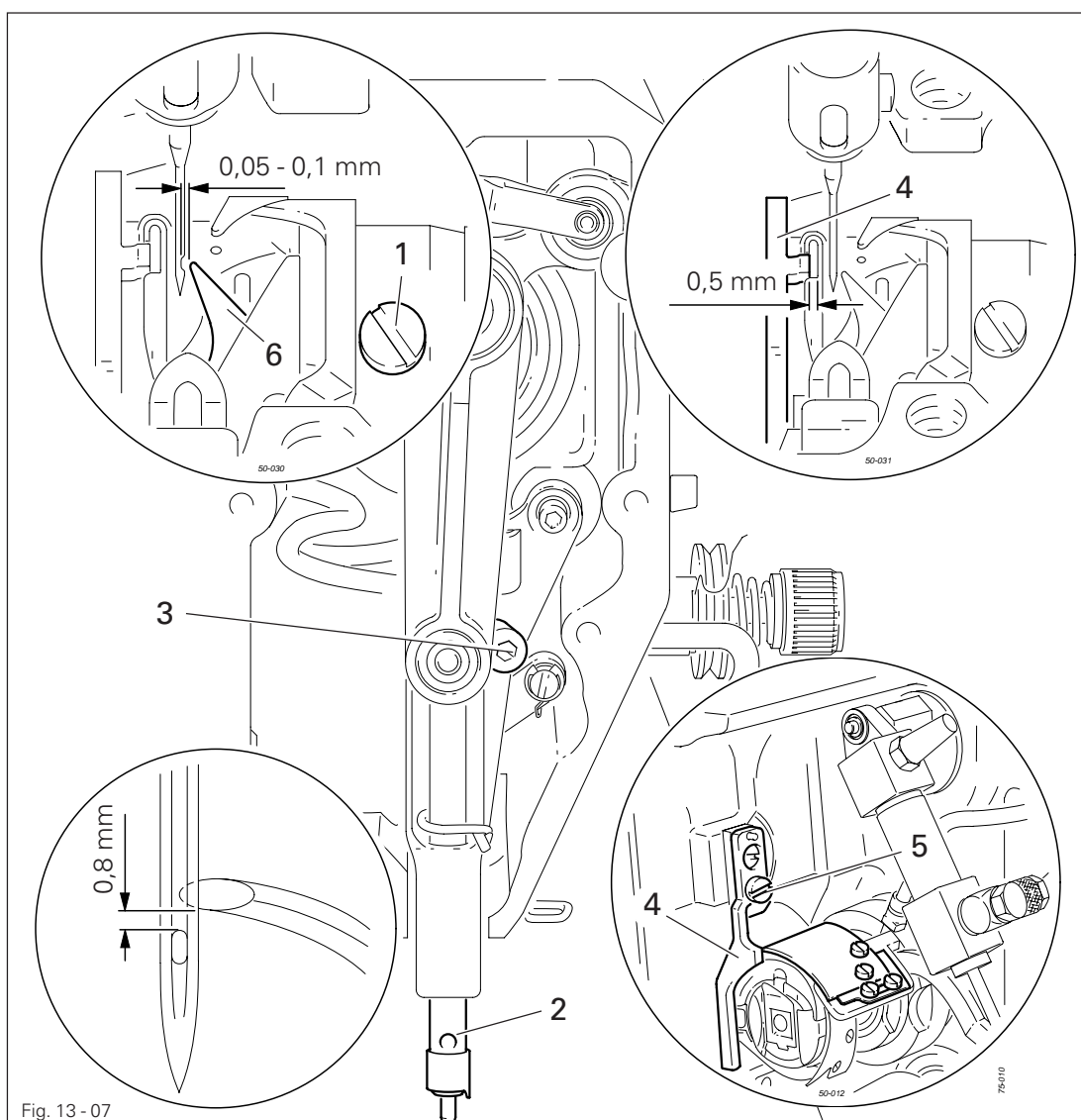

- Set needle bar at 1.8 mm past b.d.c. (see **Chapter 13.05 Adjustment aids**).
- Adjust the hook according to **requirement 1**.
- Tighten screw **1**.
- Move needle bar **2** (screw **3**) without turning it according to **requirement 2**.
- Align bobbin case position finger **4** (screw **5**) according to **requirement 3**.

13.06.06 Thread check spring and slack thread regulator

Requirement

1. The motion of the thread check spring must be completed when the needle point enters the material (spring stroke approx. **7 mm**).
2. When the thread loop is at its largest when going around the hook, the thread check spring must have moved by approx. **1 mm**.

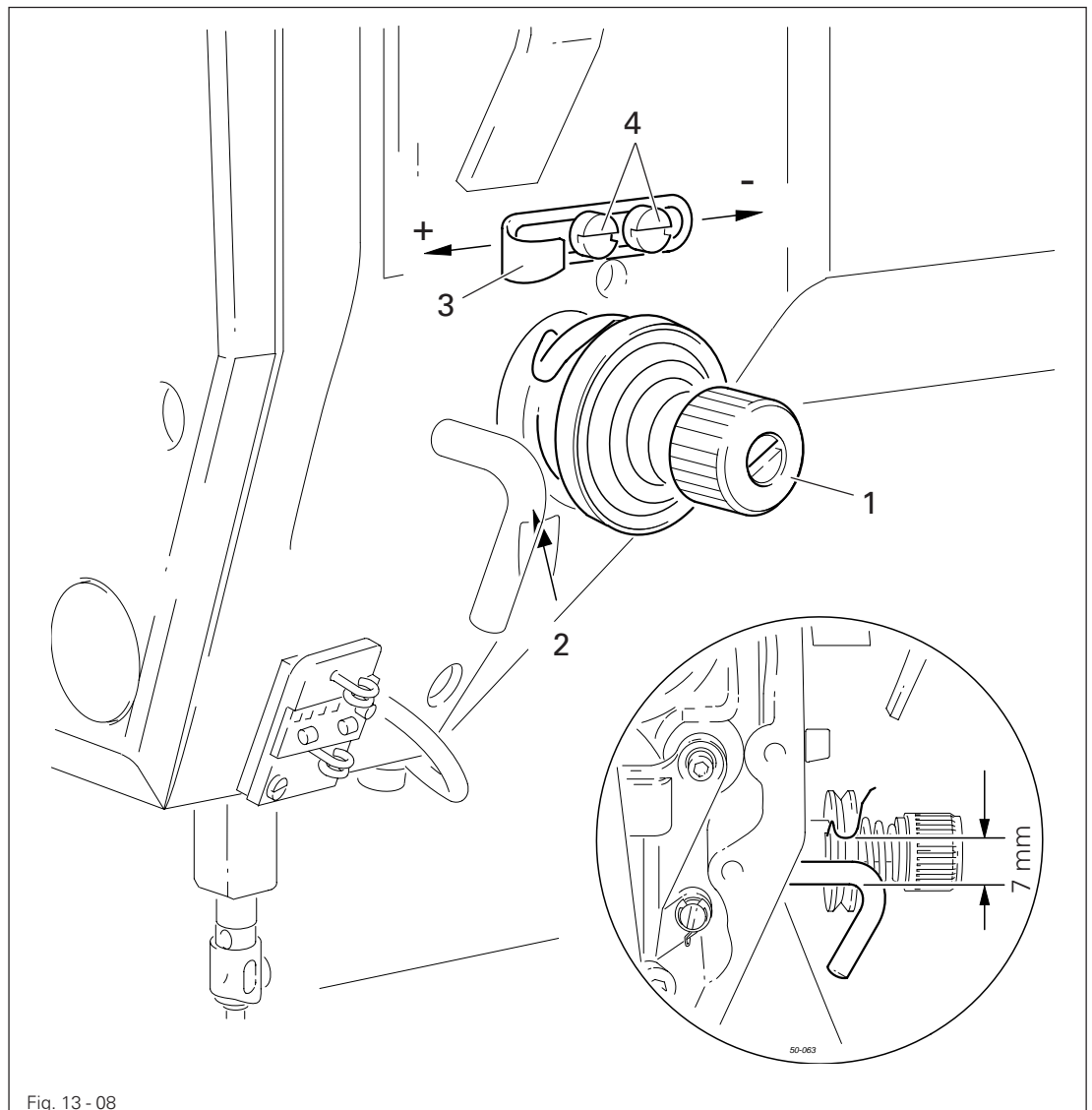
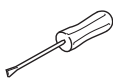

Fig. 13 - 08



- Turn thread tension 1 (screw 2) according to **requirement 1**.
- Turn thread tension 3 (screw 4) according to **requirement 2**.



Due to technical sewing reasons it may be necessary to deviate from the spring stroke indicated above.

Move the slack thread regulator 3 (screw 4) toward the "+" (= more thread) or toward the "-" (= less thread)

Requirement

1. With the bobbin winder on, the drive wheel **1** must engage reliably.
2. With the bobbin winder off, the friction wheel **5** must not be driven by the drive wheel **1**.
3. The bobbin winder must turn off automatically when the thread level is approx. **1 mm** from the edge of the bobbin.

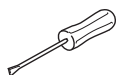
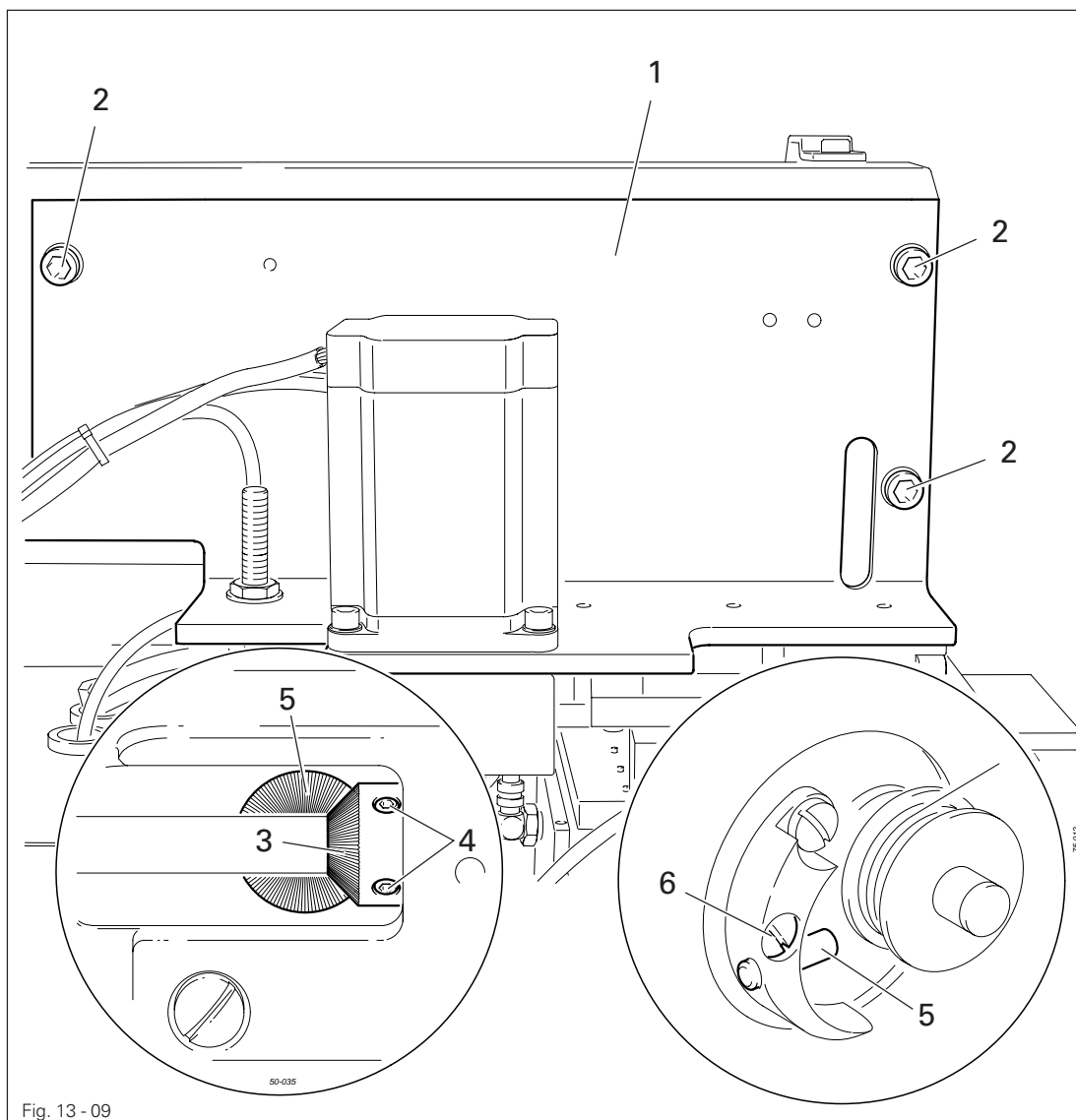

- Unscrew drive unit **1** for the Y-axis (screws **2**).
- Adjust drive wheel **3** (screws **4**) in accordance with **requirements 1 and 2**.
- Adjust stud **5** (screw **6**) in accordance with **requirement 3**.
- Screw on drive unit **1** for the Y-axis (screws **2**) parallel to the front side of the machine head.

13.07 Adjusting the thread trimming device

13.07.01 Preliminary adjustment of the control cam

Requirement

When the needle bar is at its t.d.c., the surface **1** of the control cam should be parallel to the bed-plate.

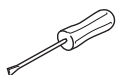
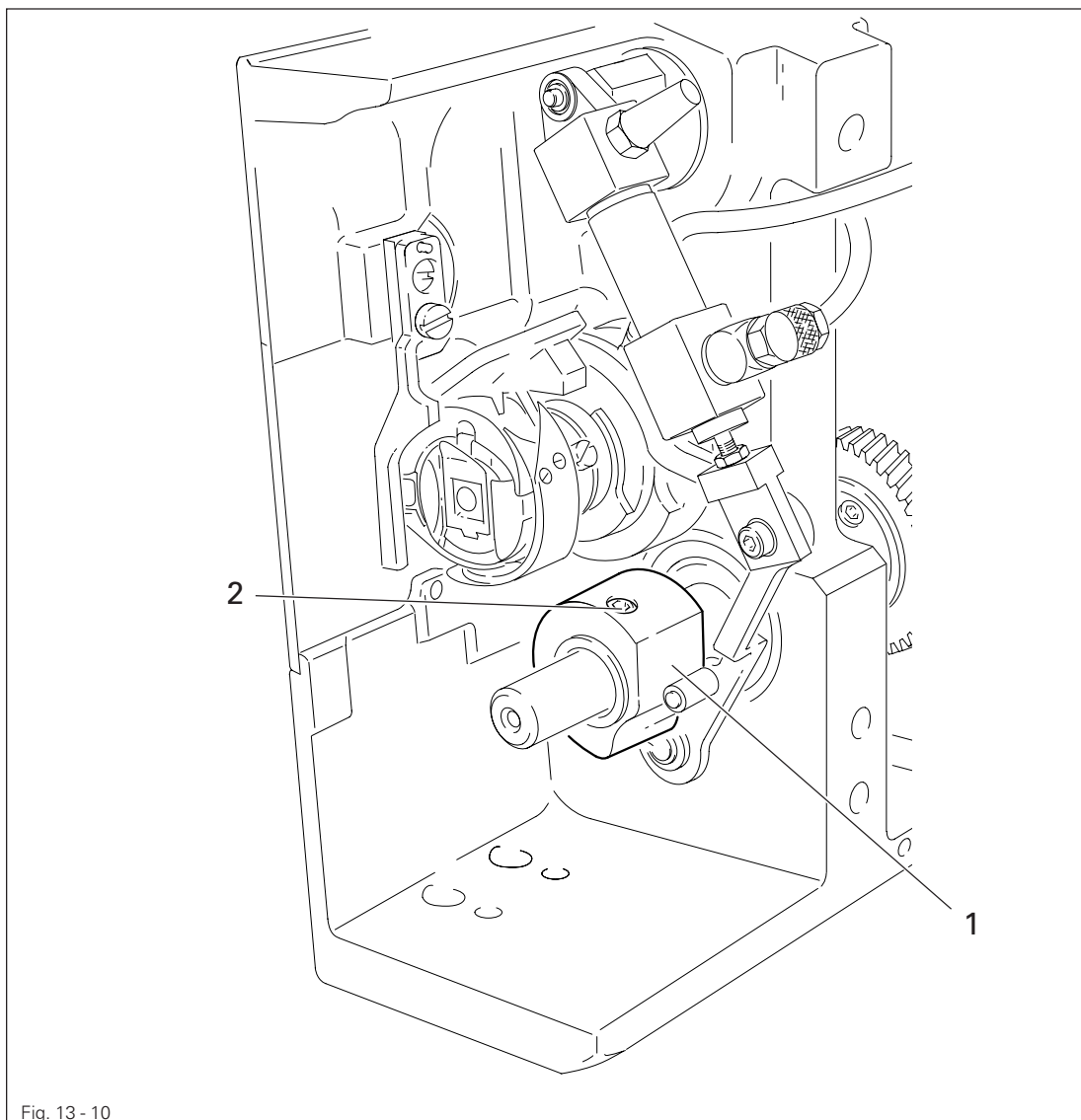

- Adjust control cam **1** (screws **2**) in accordance with the **requirement**.

13.07.02 Adjusting the roller lever

Requirement

1. When cylinder 3 is fully extended, the roller of roller lever 4 should be 0.1 mm away from the highest point of control cam 5.
2. Cylinder 3 should be parallel to the front edge of the bed-plate.

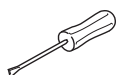
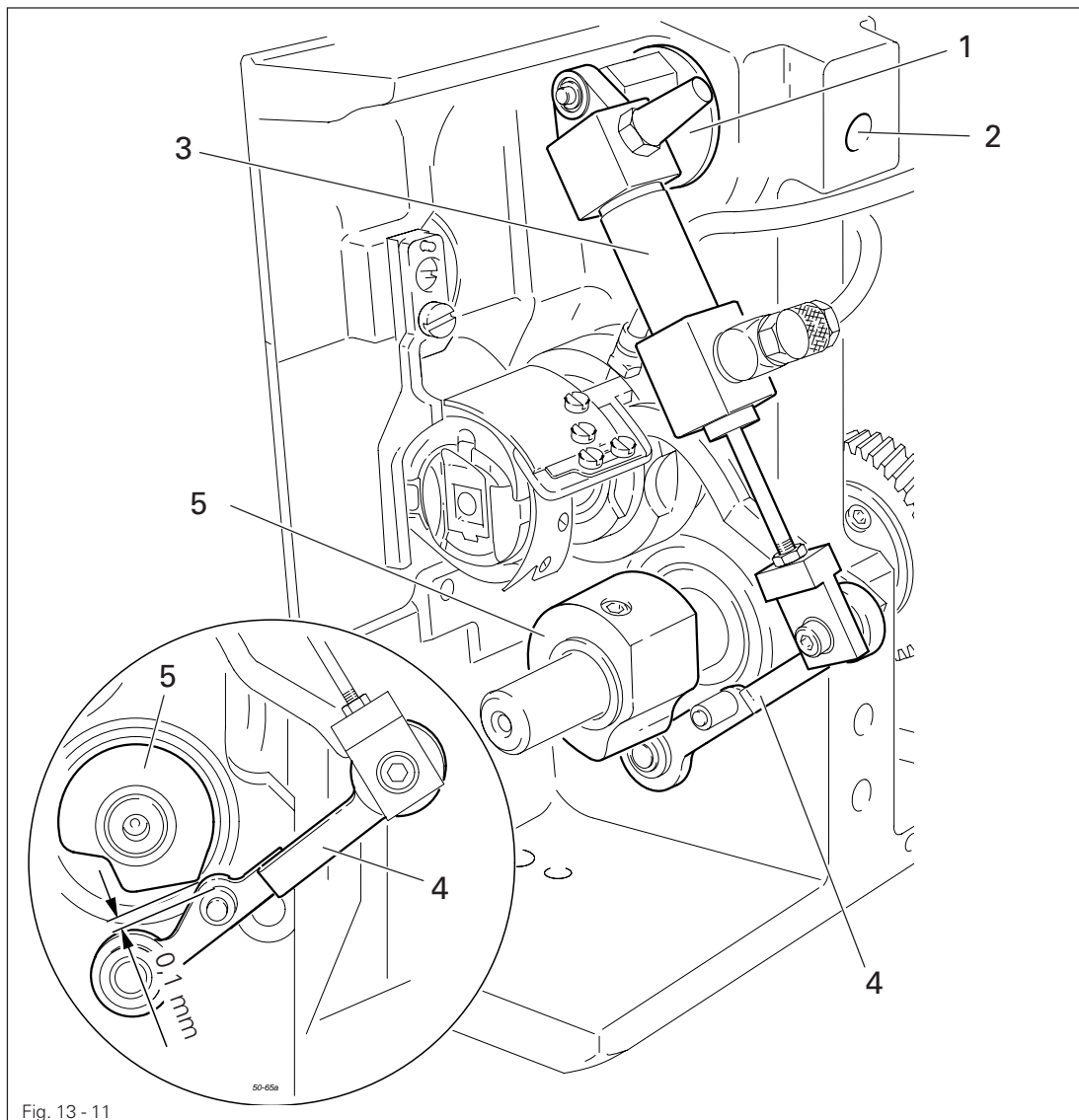

- Adjust or turn eccentric 1 (screw 2) in accordance with the requirements.

13.07.03 Lateral adjustment of the thread catcher

Requirement

1. The tip of thread catcher 5 should point exactly towards the centre of the needle.
2. The thread catcher 5 should be horizontal and not touch anything when it moves.

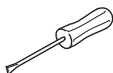
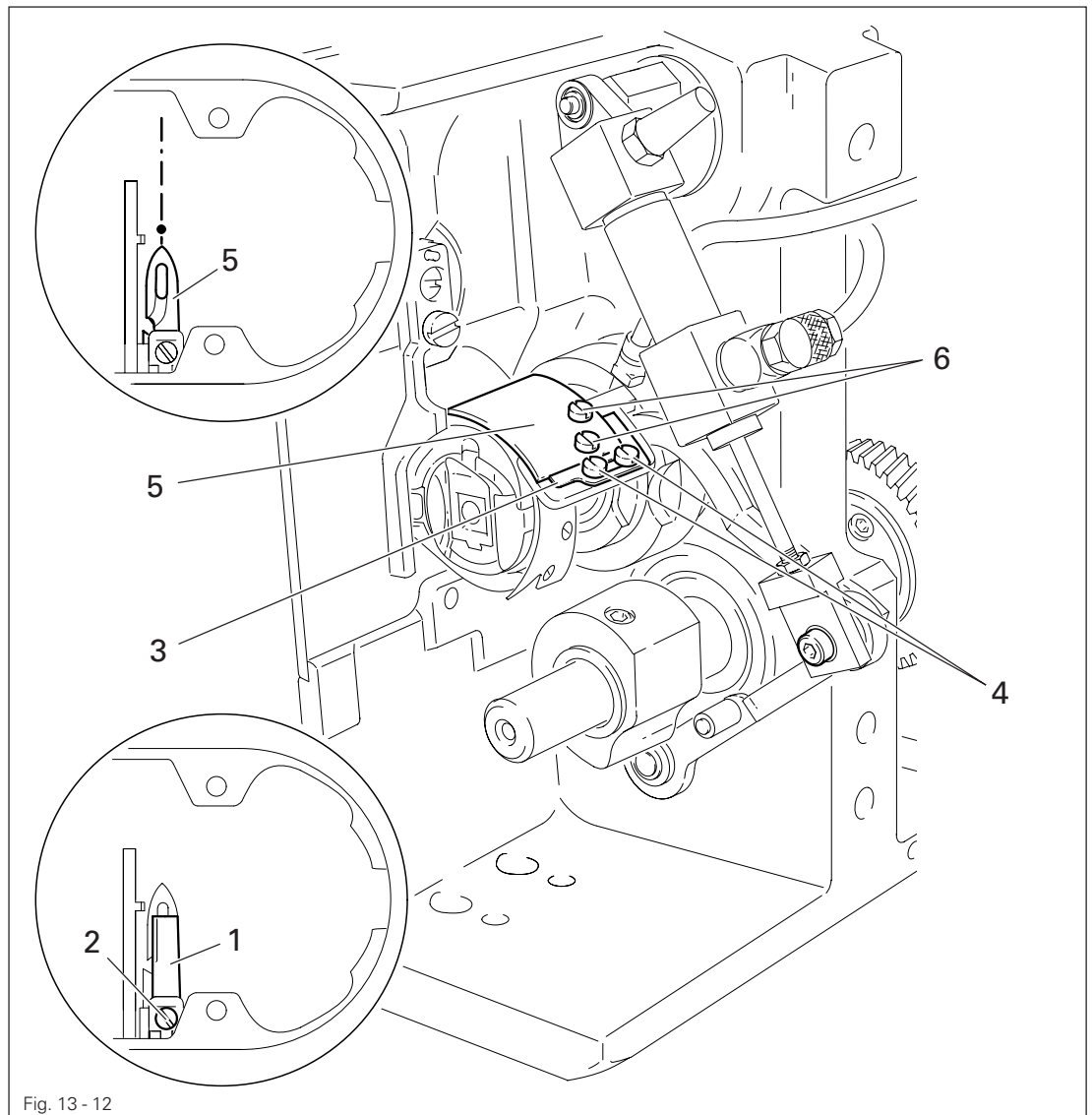

- Remove knife 1 (screw 2).
- Bring the needle bar to its b.d.c.
- Release stop 3 (screws 4).
- Position thread catcher 5 (screws 6) in front of the needle by hand, and align in accordance with the **requirements**.



For further adjustments knife 1 remains detached and stop 3 released.

13.07.04 Knife position

Requirement

1. There must be a distance of **4 mm** between the cutting edge of the knife and the needle.
2. The right edge of the knife **1** must not extend beyond the right edge of the thread catcher (see arrow).

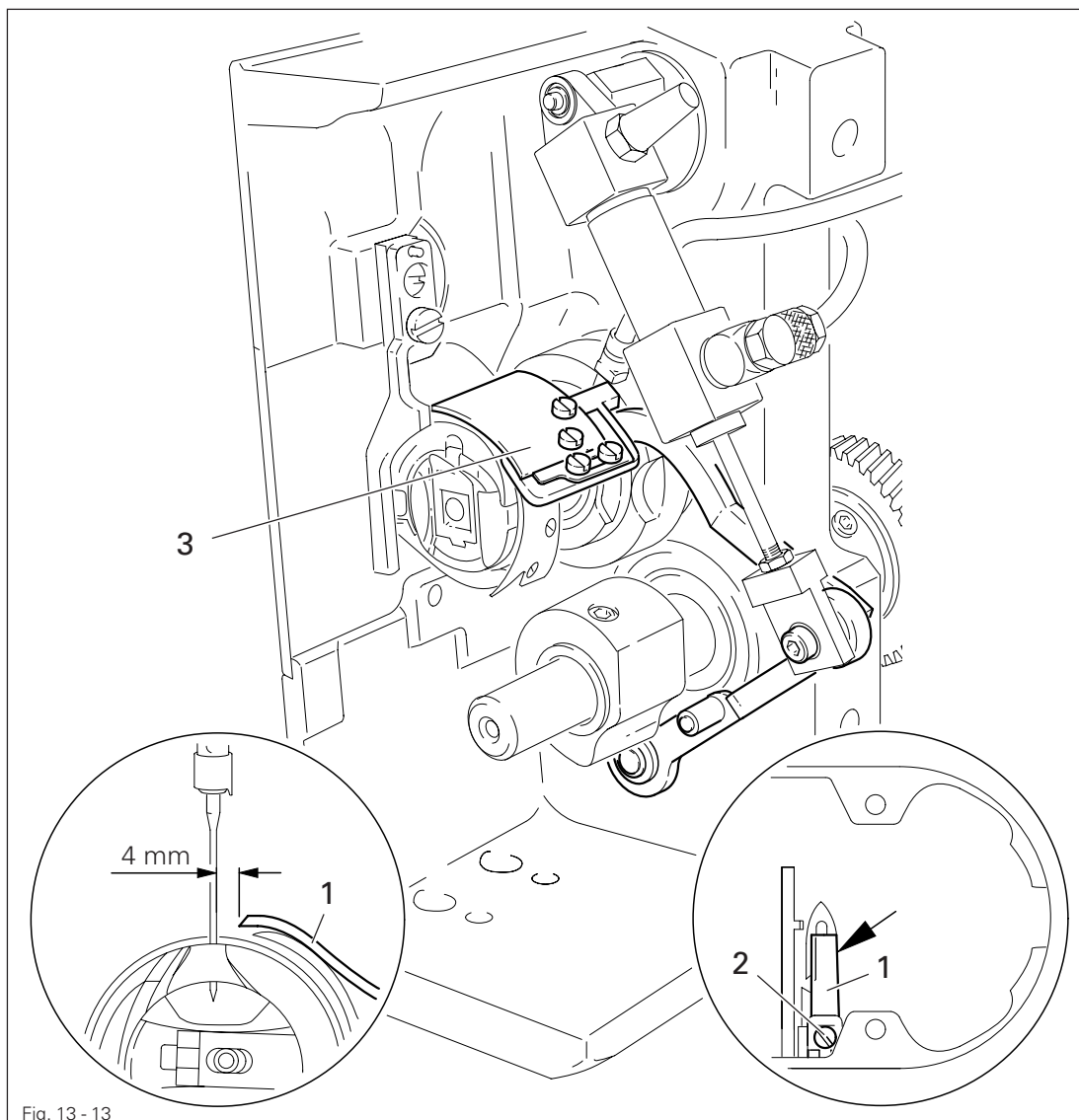
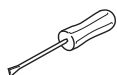

Fig. 13 - 13



- Bring the needle bar to BDC.
- Slide knife **1** under the locking tab and align according to **requirement 1**.
- Tighten screw **2** lightly.
- Adjust thread catcher carrier **3** by hand until the wedge point in the thread catcher is positioned just in front of the cutting edge of the knife.
- Align knife **1** according to **requirement 2** and tighten screw **2**.

13.07.05 Front point of reversal of the thread catcher

Requirement

When the thread catcher **5** is at its front point of reversal, the rear edge of the thread catcher cutout must be positioned **1 mm** before the bobbin case position finger **6**.

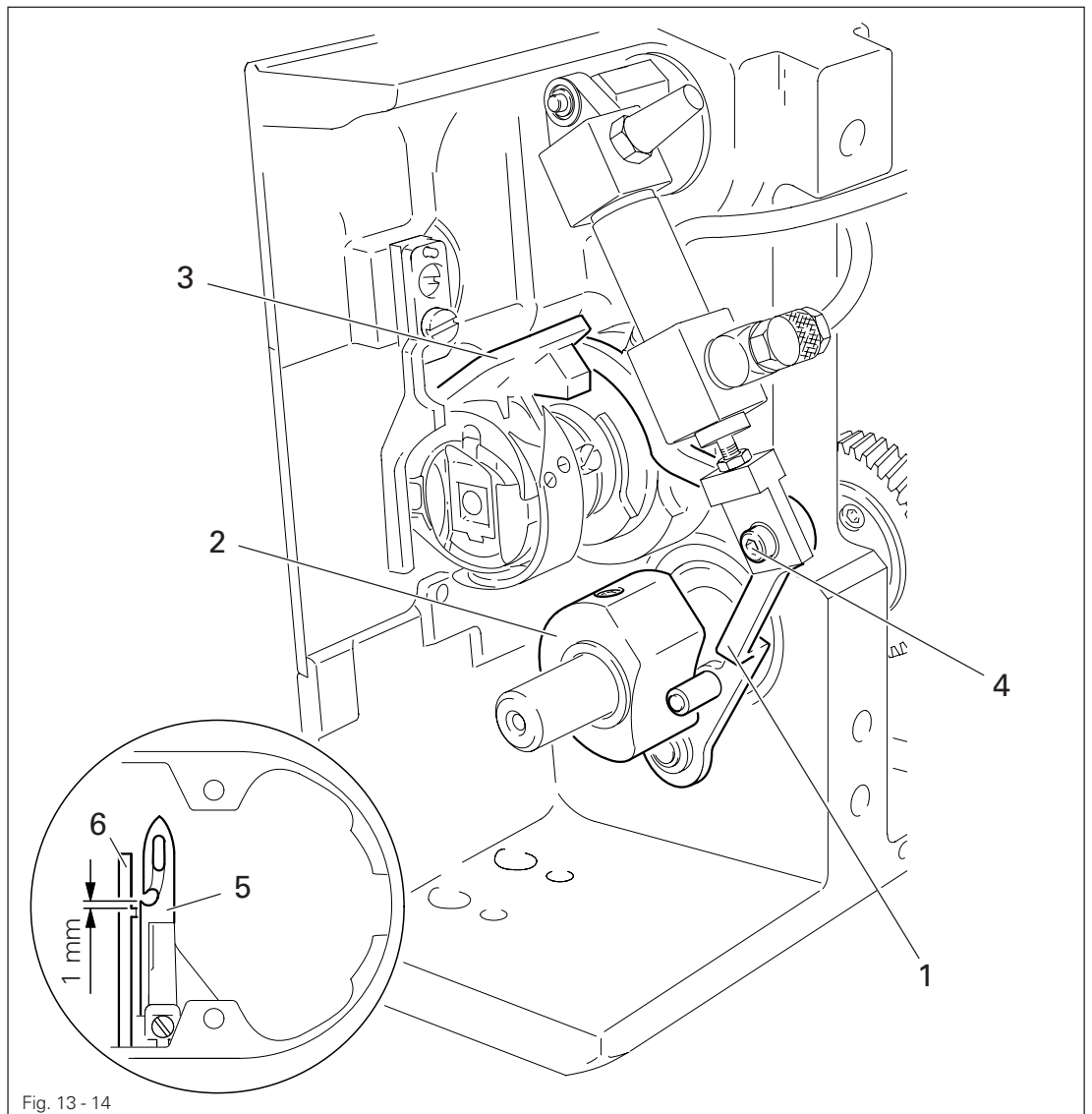
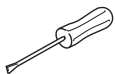

Fig. 13 - 14



- Swing roller level **1** into the lowest point of the control cam **2**.
- Move thread catcher carrier **3** (screw **4**) according to the **requirement**.

13.07.06 Manual trimming check

Requirement

Two threads must be cut perfectly both left and right in the cutout of thread catcher 1.

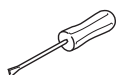
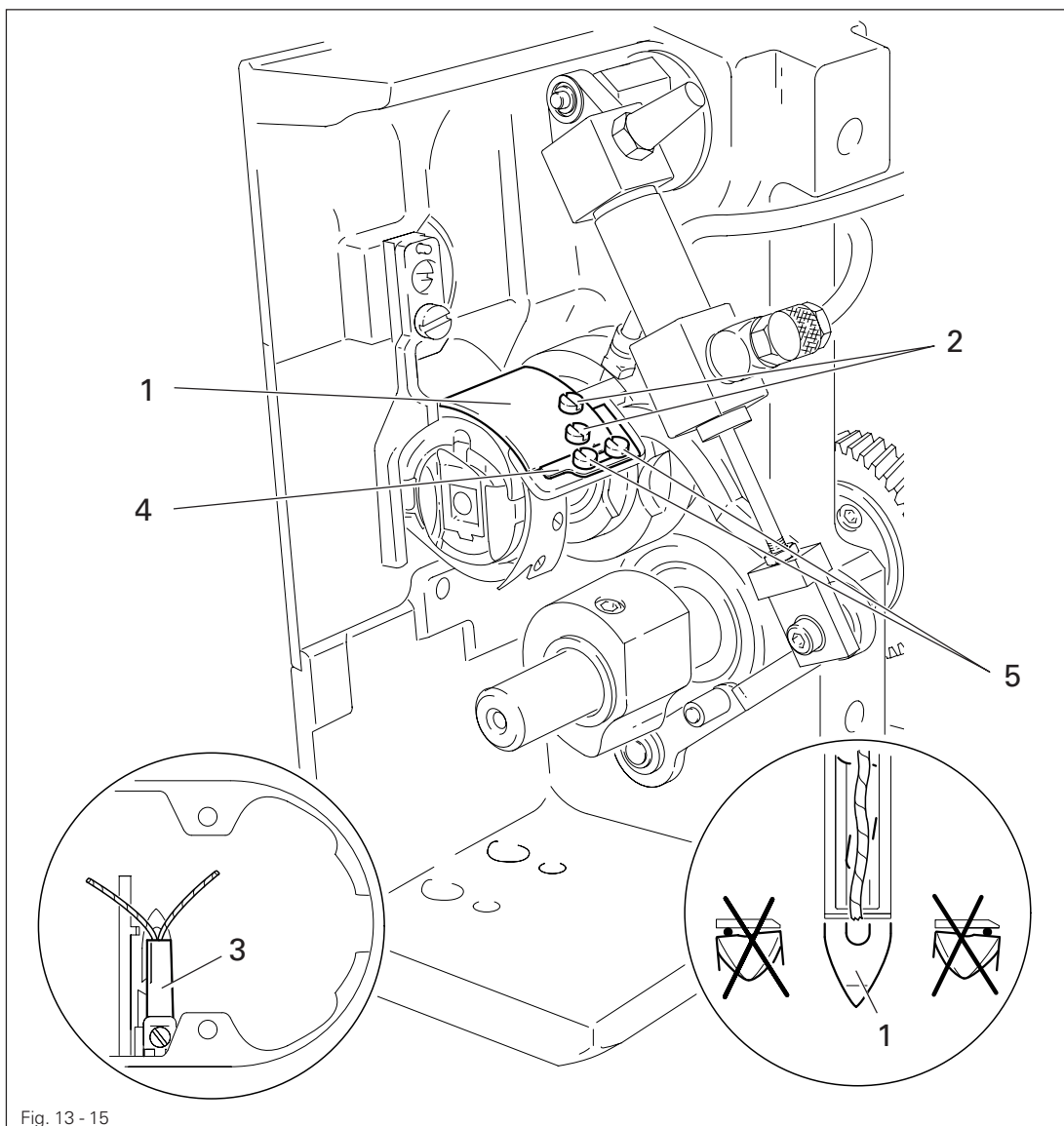

- Move thread catcher 1 by hand to its front point of reversal.
- Double the thread and insert into catcher cutout.
- Carry out trimming operation manually.
- If the threads are not cut according to the **requirement**, align thread catcher 1 (screws 2) with knife 3 accordingly.
- Move stop 4 against thread catcher 1 and tighten screws 5.
- Check chapter 11.07.03 **Lateral alignment of the thread catcher**, and readjust if necessary.

13.07.07 Readjusting the control cam

Requirement

When the end of the thread flange **3** is **2 mm** behind the centre of the catch of the bobbin case position finger **4**, there should also be a **2 mm** distance between the tip of thread catcher **6** and the centre of the catch.

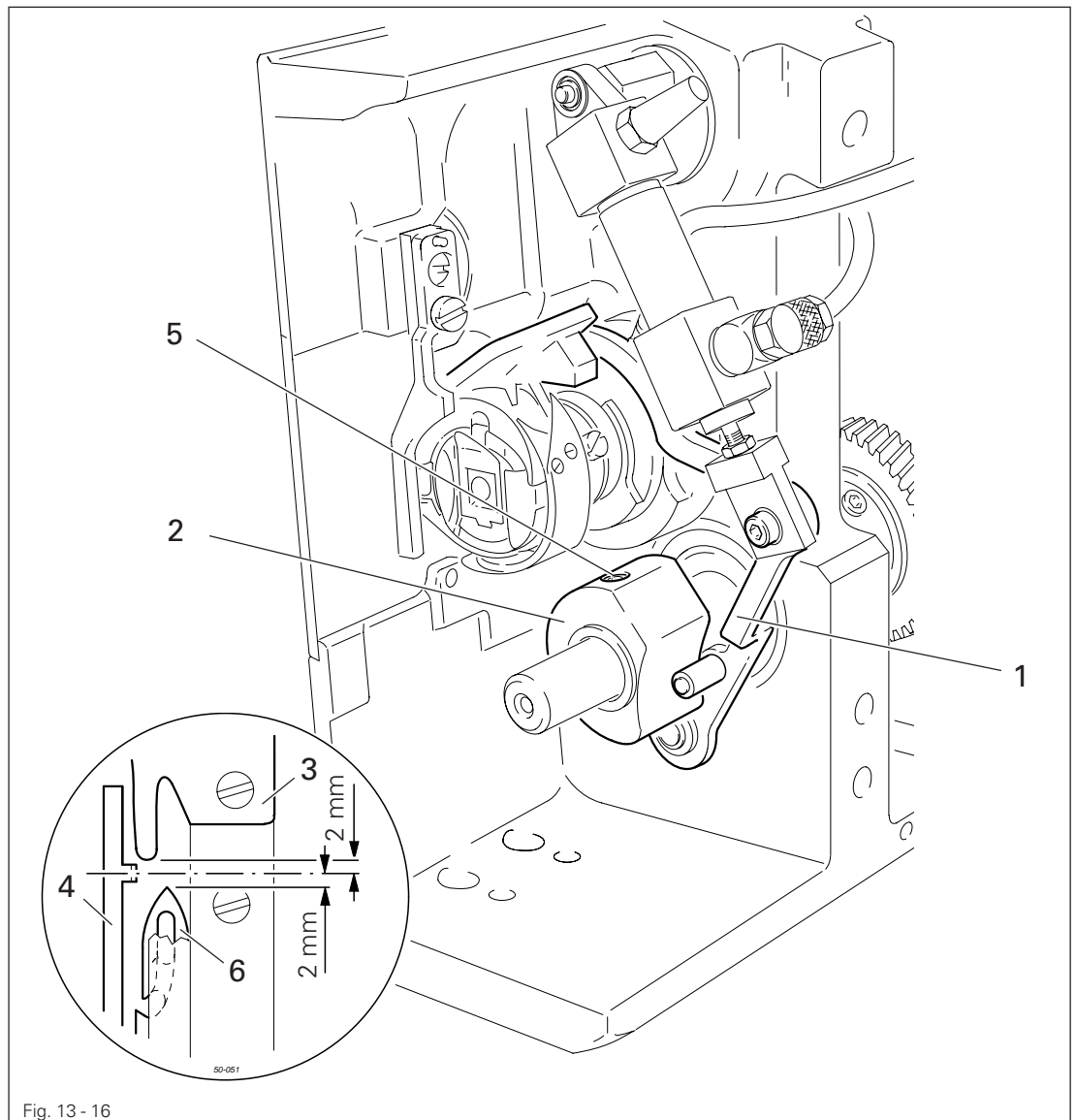
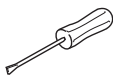

Fig. 13 - 16



- Bring the needle bar to its b.d.c.
- Press roller lever **1** by hand against the control cam **2** and turn the balance wheel until there is a distance of **2 mm** between the end of the thread flange **3** and the centre of the catch of the bobbin case position finger **4**.
- If necessary, adjust control cam **2** (screws **5**) in accordance with the **requirement**.

13.08 Adjusting the feed mechanisms

13.08.01 Aligning the fabric pressure bar

Requirement

1. The fabric should be held evenly along the entire length of the pressure bar 1.
2. When the pressure bar 1 is in its basic position (right end position) there should be a distance of 0.5 mm between the guide roller 5 and the pressure bar.

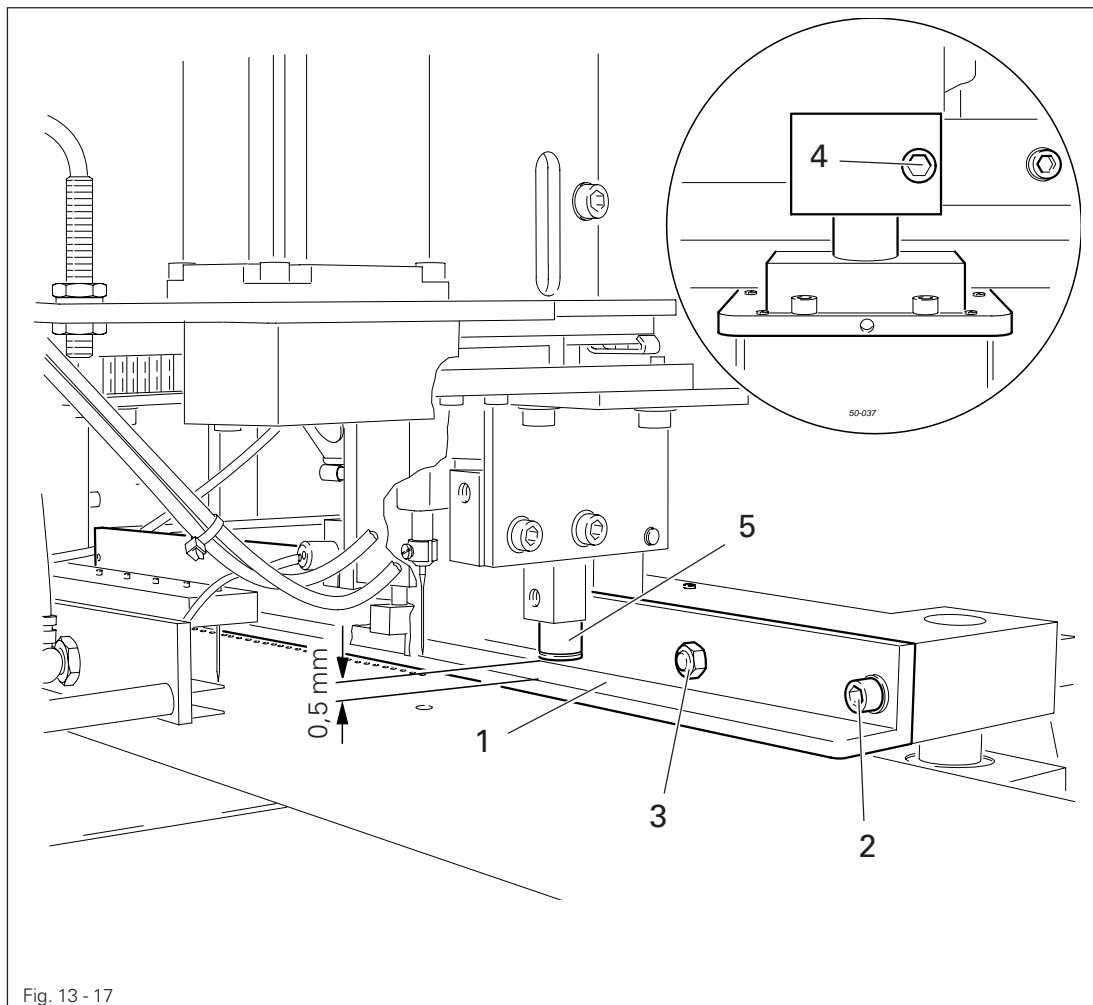
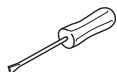

Fig. 13 - 17



- Align pressure bar 1 (screw 2 and nut 3) in accordance with requirement 1.



To control the setting, place the fabric under the pressure bar and lower the pressure bar. It must be possible to draw the fabric out evenly from below the pressure bar along its entire length.

- Adjust pressure bar 1 (screw 4) in accordance with requirement 2.

13.08.02 Aligning the drive unit of the X-axis

Requirement

The bottom edge of the guide rail **3** should be parallel at a distance of **64 mm** below the table top (without cover plate).

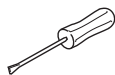
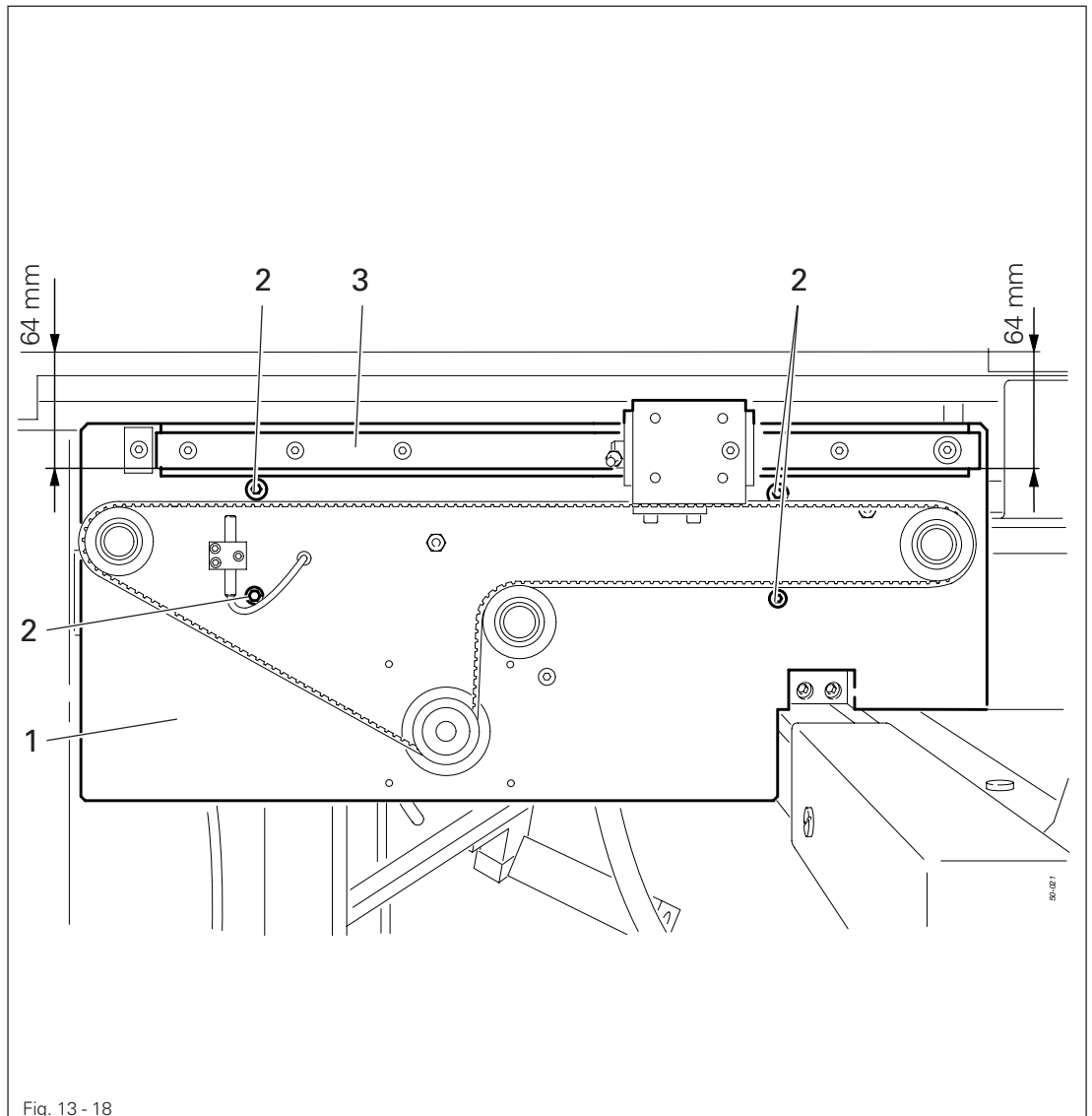

- Align drive unit **1** (Screws **2**) in accordance with the requirement.

13.08.03 Tensioning the belt on the drive unit of the X-axis

Requirement

The belt tension should be **200 Nm** and tested with measuring device **2**.

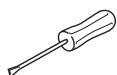
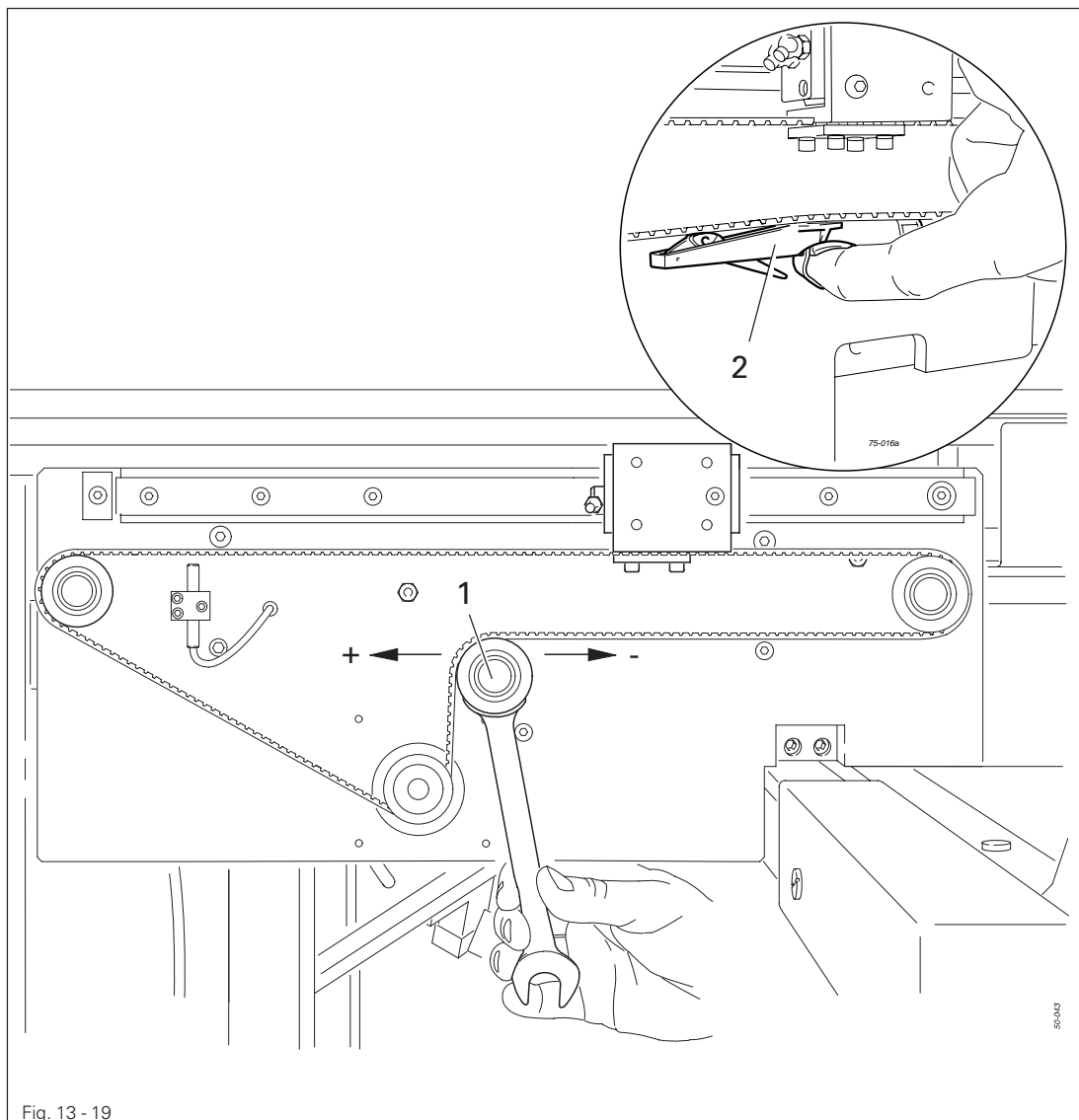

- Adjust tensioning roller 1 (counter nut, accessible from rear) in accordance with the requirement.



For information about the correct use of measuring instrument 4 (Part No. 99-137 380-91) see the enclosed instructions.

13.08.04 Stop on drive unit of the Y-axis

Requirement

Pressure bar 3 must not touch the sewing foot 4.

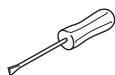
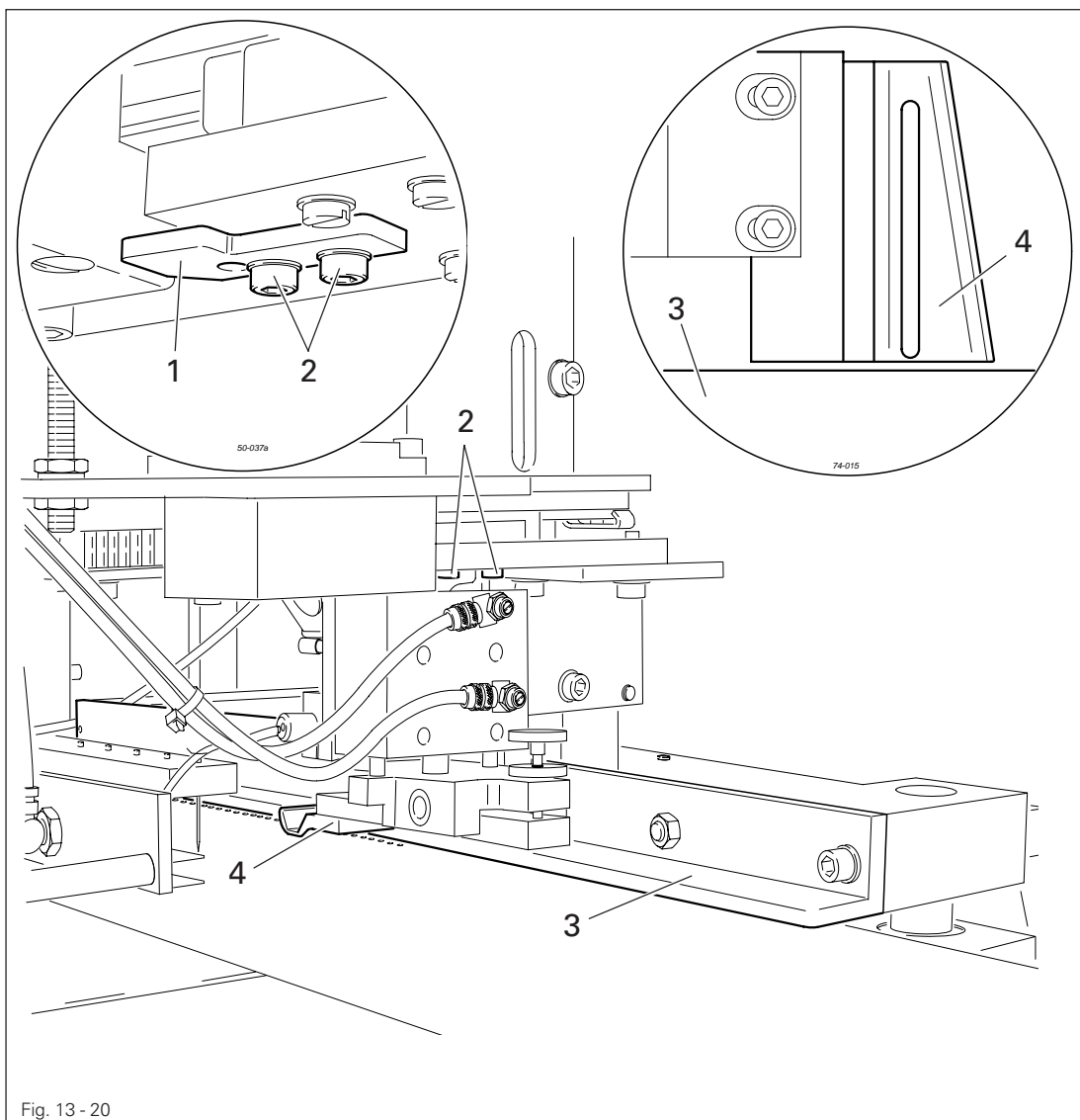

- Adjust stop 1 (screws 2) in accordance with the requirement.

Adjustment

13.08.05 Tooth flank play on the drive unit of the Y-axis

Requirement

When the machine is switched on, no play should be felt in the drive unit of the Y-axis

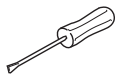
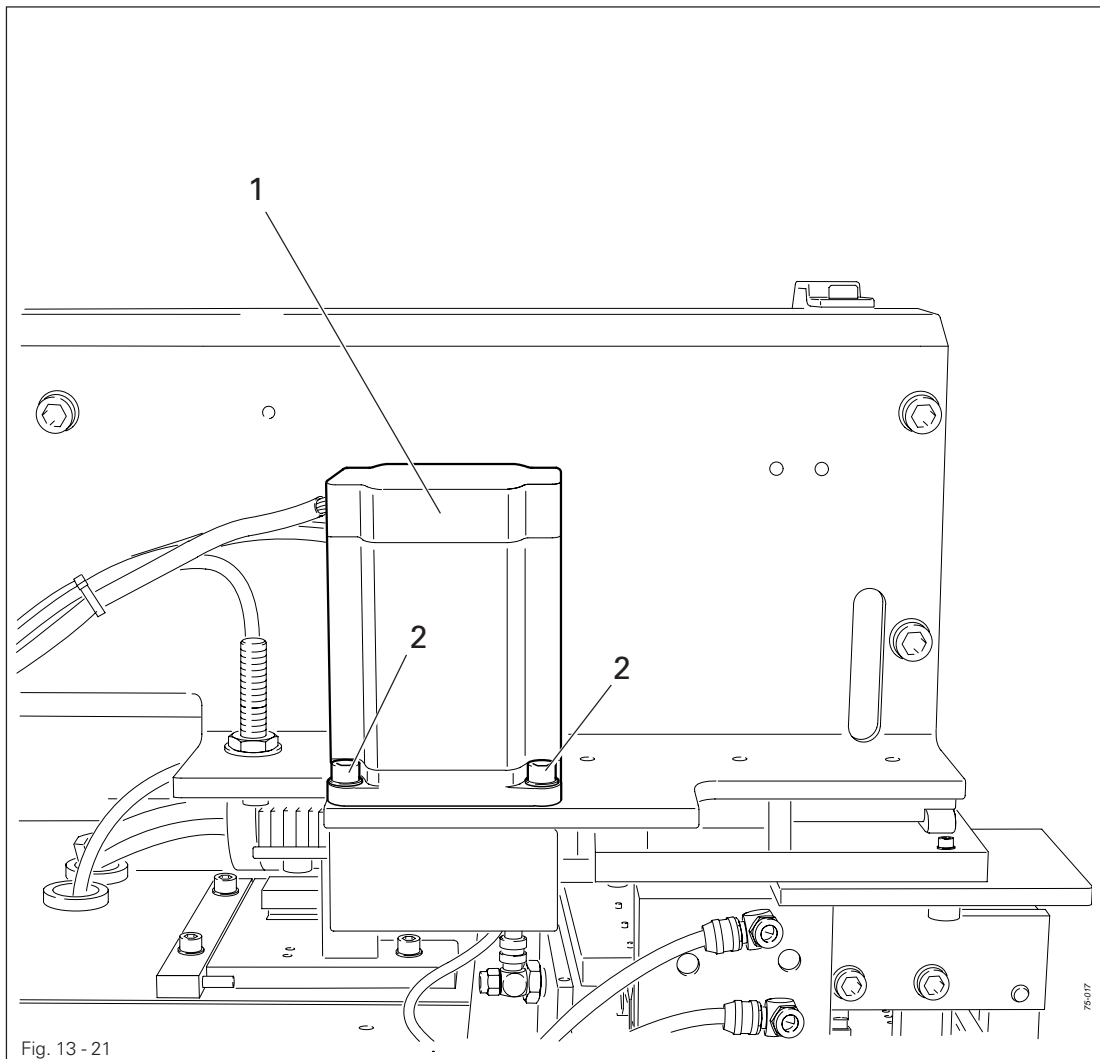

- Move motor 1 (screws 2, four screws in total) towards the machine case in accordance with the requirement.

13.08.06 Zero points of the drive units of the X and Y axes

Requirement

1. The guide rollers of the Y-drive unit and the piston rod of the X-drive unit must be positioned in the corresponding openings of the adjustment gauge 2.
2. When the balance wheel is turned, adjustment pin 1 must enter the corresponding hole of adjustment gauge 2.

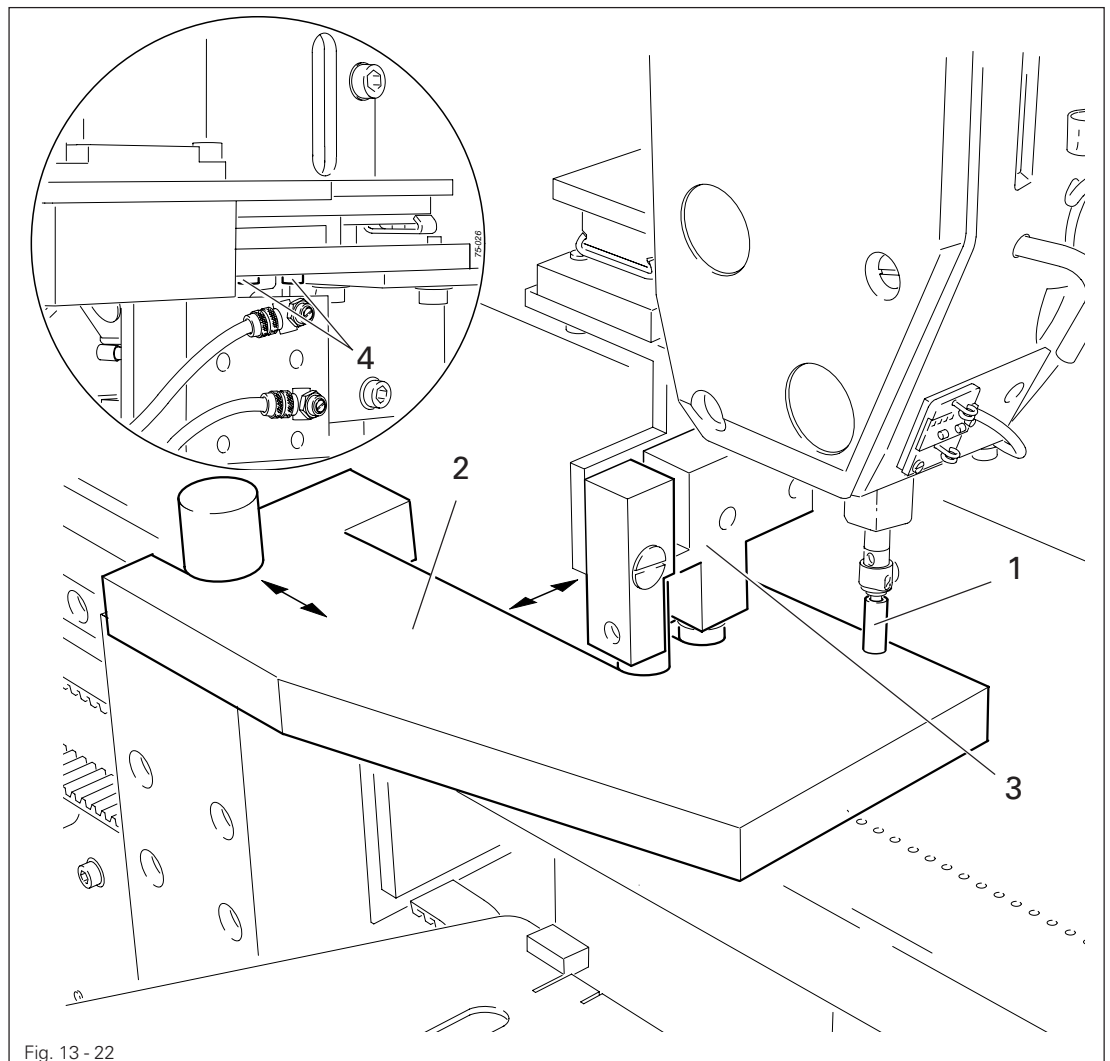
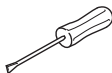
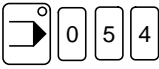

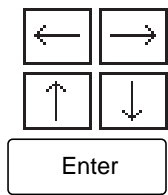

Fig. 13 - 22

- 
 - Switch on the machine.
- 
 - Select the ADJUST ZERO POINTS function on the graphics control panel.
- 
 - Select the CARRIAGE POSITION function.
 - Remove pressure bar and sewing foot.
- 
 - Move to carriage position.
 - Remove needle and insert adjustment pin 1 in the needle bar.

Adjustment



- Place adjustment gauge **2** on the cover plate.
- Move the stepping motors according to the **requirements** (number keys 1,2 and 9,0) and take over the setting with **Enter**.
- If necessary adjust guide roller bracket **3** (screws **4**) according to **requirement 1**.
- Insert disk (KONF.) and save the new zero point setting, see **Chapter 11.05 Functions in the Input mode** under SERVICE, KONF./WRITE ZERO POINTS TO DISK.
- Remove locking pin pin **1** and adjustment gauge **2**.
- Fit pressure bar and sewing foot.

13.08.07 Zero point of the material take-over unit

Requirement

The lowered needle strip 1 should be parallel to the pressure bar 2 at a distance of 3 mm.

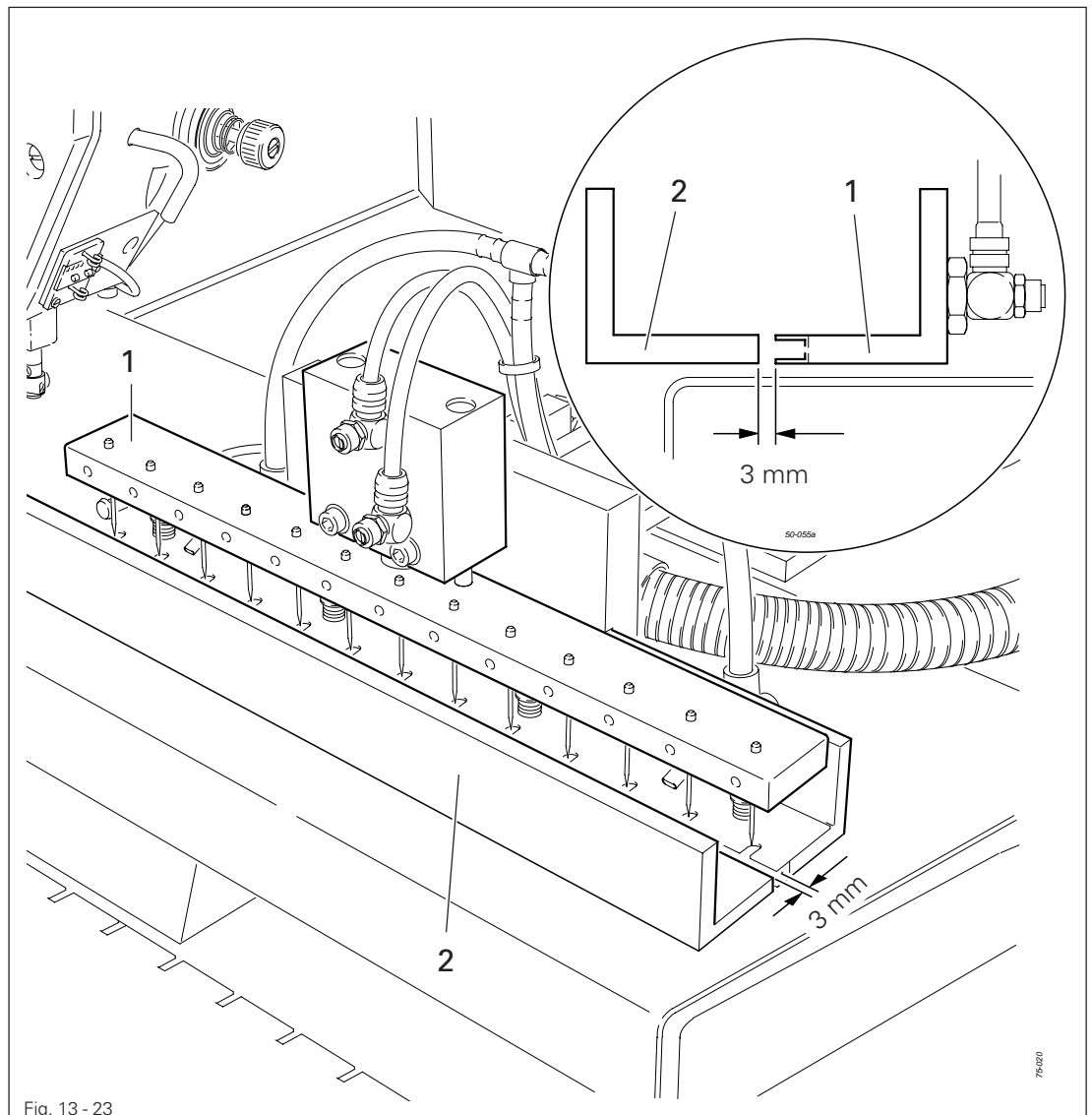
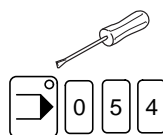

Fig. 13 - 23



- Switch on the machine.
- Select the ADJUST ZERO POINTS function on the graphics control panel.



- Select the DEPTH function.

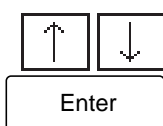

- Move the needle strip 1 according to the **requirement** (number keys 1 and 2) and take over the setting with **Enter**.

- Insert disk (KONF.) and save the new zero point setting, see **Chapter 11.05 Functions in the Input mode** under SERVICE, KONF./WRITE ZERO POINTS TO DISK.

13.08.08 Needle height of the material take-over unit

Requirement

When the needle strip is lowered, all needles **1** should be positioned **0,5 mm** above the cover plate.

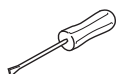
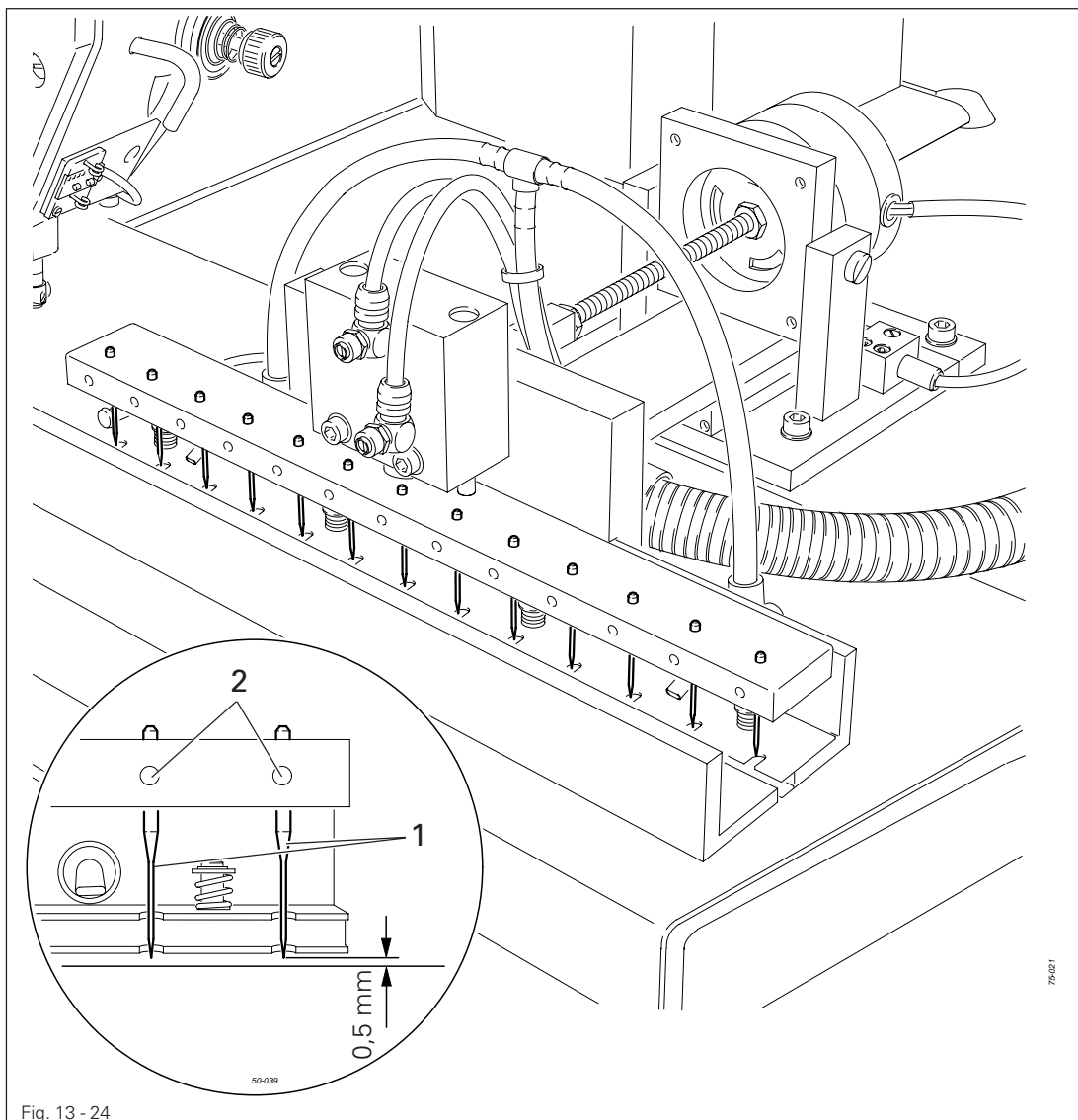

- Switch on the machine.

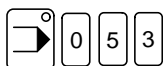

- Select the INPUTS/OUTPUTS function on the graphics control panel.



- Press number key 0.

- Select code number 3 and lower the material take-over unit.

- Adjust needles 1 (screws 2) according to the requirement.

13.08.09 Adjusting the loading table

Requirement

When the loading table **3** has been inserted, it should be positioned in the centre of the cutout of the material take-over unit **4**, and parallel to the material take-over unit **4** and the cover plate.

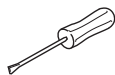
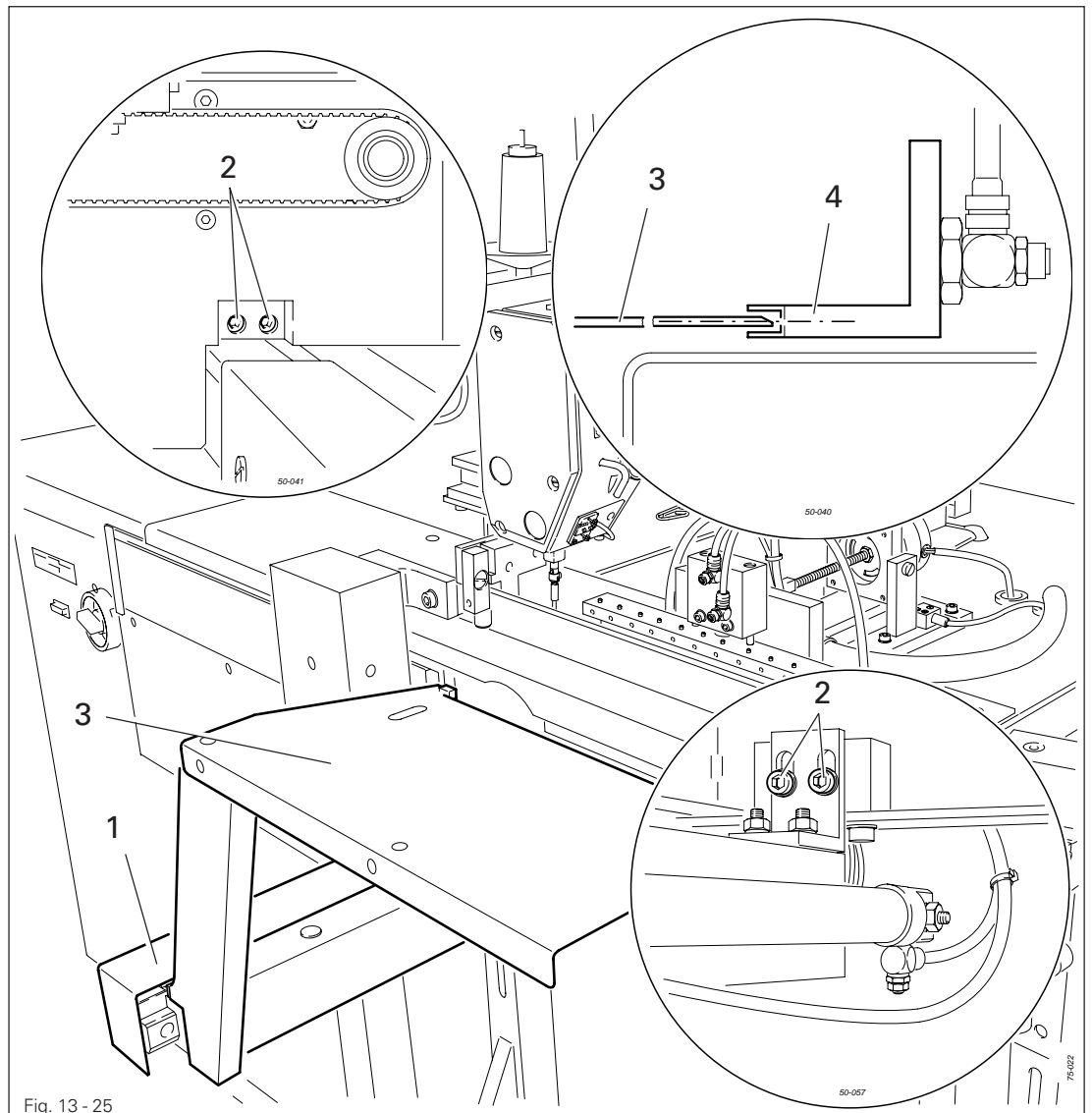

- Adjust guide unit **1** (screws **2**) according to the requirements.

Adjustment

13.08.10 Adjusting the needle position

Requirement

The needle should be positioned at t.d.c.

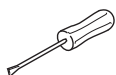

- Switch on the machine.



- Select the ADJUST ZERO POINTS function on the graphics control panel.



- Select the NEEDLE POSITION function.

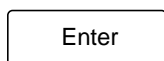
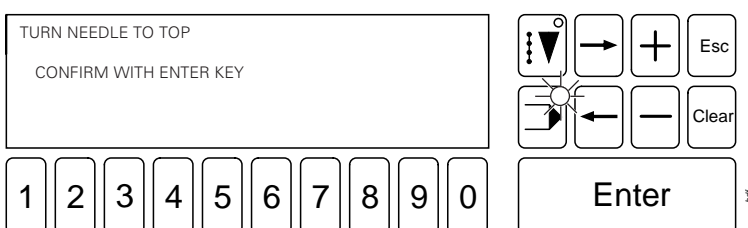

- By turning the balance wheel position the needle bar at its top dead centre and press Enter.

13.08.11 Correcting the start point

Requirement

1. On seams without start backtacks, the first stitch must be set securely in the workpiece.
2. On seams with start backtacks, the backtack stitch must be set in the workpiece.

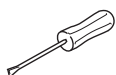

- Switch on the machine.



- Select the ADJUST ZERO POINTS function on the graphics control panel.



- Select the CORRECTION VALUE START POINT function.

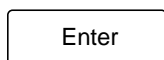
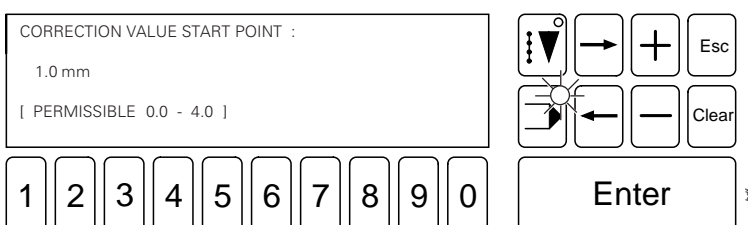

- Enter correction value with the **number keys** in accordance with the **requirement**.

- Press Enter.

13.08.12 Adjusting the presser foot

Requirement

1. When presser foot 1 is lowered, the presser foot shoe should be 1.5 mm above and parallel to the table top.
2. Needle 4 should be located in the centre of the cutout of presser foot 1.

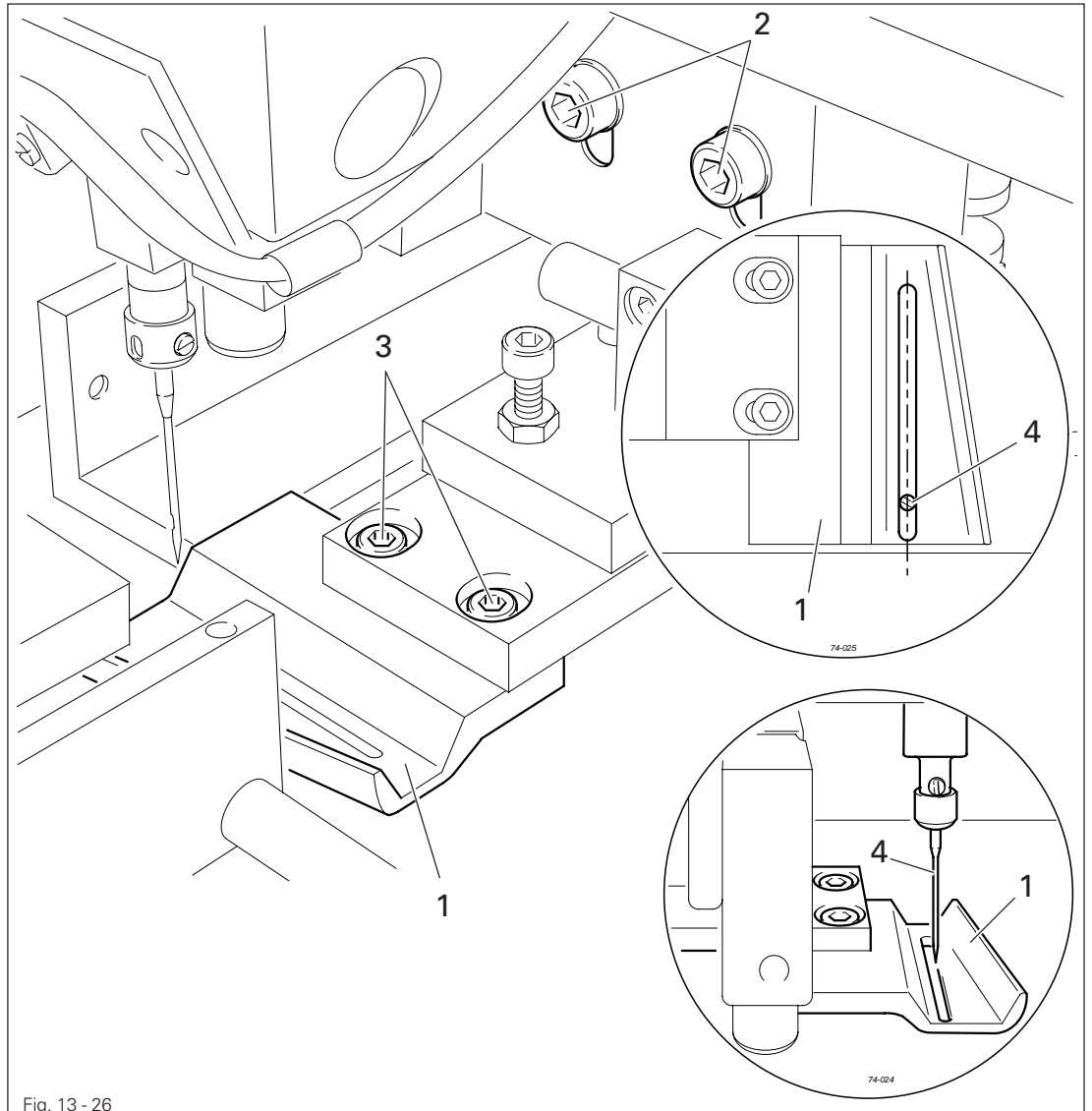
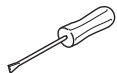

Fig. 13 - 26



- Adjust presser foot 1 (screws 2) in accordance with requirement 1.
- Adjust presser foot 1 (screws 3) in accordance with requirement 2.

		Chapter - Page
	Contents	
14	Control unit	14 - 1
14.01	Basic setting / Diagnosis / Pin assignment	14 - 1
14.01.01	Power unit A30	14 - 1
14.01.02	Basic control unit A20	14 - 3
14.01.03	Sewing drive A22	14 - 5
14.01.04	List of parameters - Sewing drive	14 - 6
14.01.05	Stepping motor drive A40	14 - 7
14.01.06	CAN node A10	14 - 8
14.02	Error description	14 - 10
14.02.01	Example of an error message	14 - 10
14.02.02	Sewing drive error	14 - 11
14.02.03	Errors – Stepping motor drive	14 - 12
14.02.04	Error during stitch generation	14 - 14
14.03	Tables	14 - 15
14.03.01	Tables for lock/release functions	14 - 15
14.03.02	Machine data table (MDAT)	14 - 18
14.03.03	Table of outputs	14 - 19
14.03.04	Table of inputs	14 - 19
15	Circuit diagrams	15 - 1

Control unit

14 Control unit

14.01 Basic setting / Diagnosis / Pin assignment

14.01.01 Power unit A30

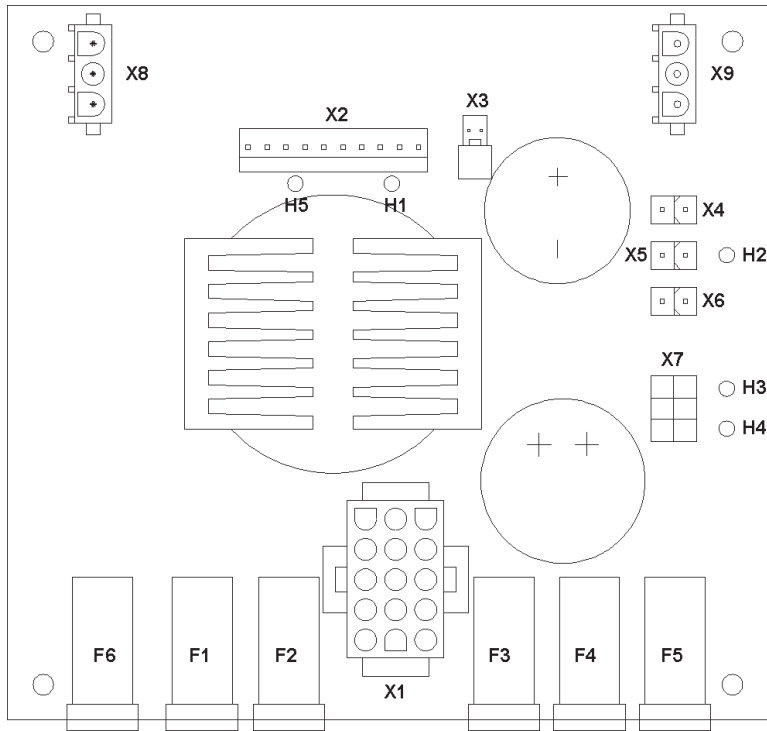

Voltage	Fuse	LED
230 V AC (mains)	F6 (6.3 A T)	-
5 V DC (processor)	F1 (2 A T)	H1
18 V DC (control panel)	F2 (500 mA T)	H5
24 V DC (I/O)	F3 (2.5 A T)	H2
80 V DC (stepping motor)	F4 (6.3 A T)	H3
24 V DC (stepping motor)	F5 (500 mA T)	H4

Pin assignment

X 1 (transformer secondary)

PIN	Signal	PIN	Signal
3	V1 18 V AC 1	7	V4 57 V AC 1
9	V1 18 V AC M	13	V4 57 V AC M
6	V1 18 V AC 2	10	V4 57 V AC 2
12	V2 18 V AC	11	V5 18 V AC
15	V2 18 V AC	14	V5 18 V AC
2	V3 18 V AC 1	5	
4	V3 18 V AC M	8	
1	V3 18 V AC 2		

X 2 (BS3)

PIN	Signal
1	GND 5 V
2	GND 5 V
3	GND 5 V
7	18 V AC
9	POWERF

PIN	Signal
4	5 V
5	5 V
6	5 V
8	18 V AC
10	V1 18 V

X 3 (Fan), X4, X5, X6

PIN	Signal
1	24 V (I/O)

PIN	Signal
2	GND 24 V

X 7 (sm-end phase)

PIN	Signal
1	24 V (SM)
2	80 V (SM)
3	80 V (SM)

PIN	Signal
4	GND 24 V (SM)
5	GND 80 V (SM)
6	GND 80 V (SM)

X 8 (Mains)

PIN	Signal
1	PE
3	L1

PIN	Signal
2	N

X 9 (Transformer primary)

PIN	Signal
1	PE
3	L1

PIN	Signal
2	N

X301 (X-axis / motor 1)

X302 (Y-axis / motor 2)

X303 (Depth / motor 3)

PIN	Signal	PIN	Signal
-----	--------	-----	--------

1	Pulse +	9	Pulse -
---------	---------	---------	---------

2	Direction +	10	Direction -
---------	-------------	----------	-------------

3	Gate/Enable +	11	Gate/Enable -
---------	---------------	----------	---------------

4	Current control +	12	Current control -
---------	-------------------	----------	-------------------

5	Vex +	13	Vex -
---------	-------	----------	-------

6			
---------	--	--	--

7	Input 2 +	14	Input 2 -
---------	-----------	----------	-----------

8	Input 1 +	15	Input 1 -
---------	-----------	----------	-----------

X208 (CAN-Bus)

PIN	Signal	PIN	Signal
-----	--------	-----	--------

1	P8HA +	6	
---------	--------	---	--

2	P8HA -	7	
---------	--------	---	--

3	DoRi +	8	DoRi -
---------	--------	---------	--------

4	GND	9	GND
---------	-----	---------	-----

5			
---	--	--	--

X400 (main drive)

PIN	Signal	PIN	Signal
-----	--------	-----	--------

1	Screening	14	A_A
---------	-----------	----------	-----

2	TxD_A	15	A_B
---------	-------	----------	-----

3	RxD_A	16	B_A
---------	-------	----------	-----

4	TxD_B	17	B_B
---------	-------	----------	-----

5	RxD_B	18	I_A
---------	-------	----------	-----

6		19	I_B
---	--	----------	-----

7	GND	20	GND
---------	-----	----------	-----

8		21	A_OC
---	--	----------	------

9	R1_A	22	B_OC
---------	------	----------	------

10	R1_B	23	I_OC
----------	------	----------	------

11	R2_A	24	V2
----------	------	----------	----

12	R2_B	25	GND
----------	------	----------	-----

13	GND	26	Vex
----------	-----	----------	-----

X401 (thread monitor)

PIN	Signal	PIN	Signal
-----	--------	-----	--------

1	+U_ULN	2	+U_ULN
---------	--------	---------	--------

3	POUT7	4	POUT8
---------	-------	---------	-------

14.01.03 Sewing drive A22



Before leaving the factory the sewing drive controller is equipped with the necessary operating software. This software may only be replaced by appropriately trained personnel.

The LED "Power on" shows that the unit is ready for operation. Diagnosis functions and fuses are not available. If error messages appear on the machine display, see **Chapter 14.02.02 Error in sewing drive**

Pin assignment

X2 (Synchronizer)

PIN	Signal	PIN	Signal
1	KA	6	
2	KB	7	
3	KC	8	
4	ADTC2	9	GND
5	+ 5V		

X3 (Interface)

PIN	Signal	PIN	Signal
1	GND	14	A
2	TxD	15	A\
3	RxD	16	B
4	TxD\	17	B\
5	RxD\	18	Index
6		19	Index\
7	GND	20	
8		21	
9	REF1	22	
10	REF1\	23	
11	REF2	24	
12	REF2\	25	
13	GND	26	

X6 (Mains)

PIN	Signal	PIN	Signal
1	PE	2	N
3	L1		

X14 (Motor)

PIN	Signal	PIN	Signal
1	PE	3	V
2	U	4	W

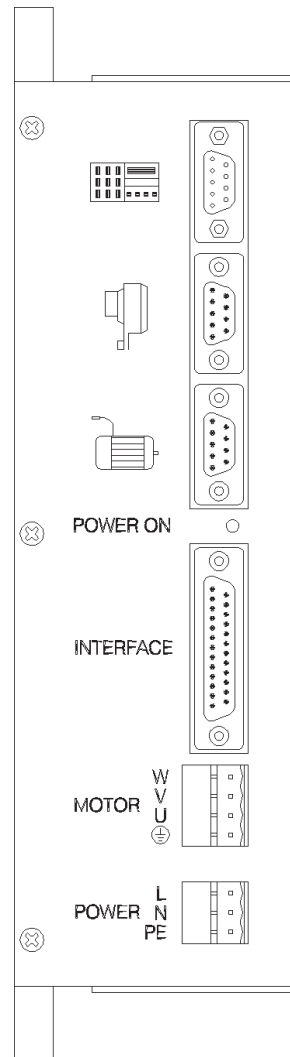

14.01.04 List of parameters - Sewing drive

Parameter	Denomination	Range		Default	
		min.	max.	(Quick)	3586
(606)OD _H	minimum speed (in 10 min ⁻¹)	3	64	(20)	3
(607)OE _H	maximum speed (in 100 min ⁻¹)	1	100	(15)	45
(609)10 _H	positioning speed (in 10 min ⁻¹)	3	25	(20)	20*
(718)07 _H	rest brake power	0	100	(0)	0
(722)11 _H	positive ramp (in ms ⁻¹)	1	50	(45)	45
(723)12 _H	negative ramp (in ms ⁻¹)	1	50	(30)	45
(804)15 _H	count position (in incr.)	0	239	(120)	0
(840)1C _H	time-out (in 10 ms)	1	100	(10)	10
(841)16 _H	reference signal 1 (in incr.)	0	239	(0)	60*
(842)17 _H	reference signal 2 (in incr.)	0	239	(0)	133*
(843)1F _H	machine code	0	255	(255)	2
(850)OF _H	max. motor speed (in 100 min ⁻¹)	20	60	(50)	50
(851)	steep brake ramp for path monitoring	see par. 08 _H		(Bit7 = 1)	Bit7 = 1
(852)18 _H	altern. pos. ramp (in 0.1 min)	1	250	(10)	-
(853)19 _H	altern. neg. ramp (in 0.1 min)	1	250	(10)	-
(854)	braking when power off	see par. 08 _H		(Bit3 = 1)	Bit3 = 1
(884)00 _H	P-quota speed controller	1	50	(12)	15
(885)01 _H	I-quota speed controller	0	100	(30)	60
(886)02 _H	P-quota position controller	1	50	(20)	20
(887)03 _H	D-quota position controller	1	100	(30)	30
(889)04 _H	time for position control (in 10 ms)	0	100	(40)	25
(890)05 _H	P-quota for rest brake	1	50	(25)	25
(891)06 _H	D-quota for rest brake	0	50	(20)	15
(894)	rotary direction synchronizer	see par.08 _H		(Bit1 = 1)	Bit1 = 1
(897)	commutating signal generator	see par. 08 _H		(Bit4 = 0)	Bit4 = 0
(898)	pole number motor	see par. 08 _H		(Bit5 = 0)	Bit5 = 0
(997)0A _H	winding resistance motor (in 100 mOhm)	10	99	(50)	50
(998)09 _H	constant of e.m.f. motor (in V/1000 rev.)	10	250	(60)	60
(999)13 _H	delay for path-optimized brakes (in ms ⁻¹)	20	50	(30)	20

* The parameter can be changed in the input and/or varies dependent on the machine type.

Special requirements for parameter 08_H

In the following byte some parameters are encrypted. These can only be changed by manipulating the corresponding bits. Bits 0, 2 and 6 may not be changed.

Bit: 7 6 5 4 3 2 1 0
1 1 0 0 1 0 1 0 (bit pattern 3586 class)

- (894) 0: rotary direction commutating signal generator
- (854) 0: motor slows down until it comes to a halt, when power off
1: motor is braked by means of e.m.f., when power off
- (897) 0: Quick commutating signal generator
1: other commutating signal generator
- (898) 0: 6-pole motor
1: 4-pole motor
- (851) 0: set value for flat ramps on stitch-counted seams (parameter 12_H < 20)
1: set value for steep ramps on stitch-counted seams (parameter 12_H > 20)

14.01.05 Stepping motor drive A40

The stepping motor controller has the following initial setting:

Motor 1: 3.5 A, SIN 8

Motor 2: 4 A, SIN 8

Motor 3: 2 A, semi-cut

Current reduction 50 %, with coupling of motor 1 and motor 2

These settings are loaded. Software number: 79-001 102-91/001



For information about LED status indications see Chapter 14.02.03 Errors - Stepping motor drive.

PIN assignment

X5 (bootstrap)

PIN	Signal	PIN	Signal
1	GND	2	BOOTSTRAP
3	RESIN	4	n.c.
5	TxD	6	RxD
7	12 Vin	8	Vpp Processor
9	5 V	10	n.c.

X10 (carriage control)

PIN	Signal	PIN	Signal
1	12 V	3	GND
2	Switch	4	n.c.

X1 (CAN-Bus)

PIN	Signal	PIN	Signal
1		6	
2		7	
3	DoRi +	8	DoRi -
4	GND	9	GND
5			

X6 (supply)

PIN	Signal	PIN	Signal
1	+24 VSM	4	GND 24 VSM
2	+80 VSM	5	GND 80 VSM
3	+80 VSM	6	GND 80 VSM

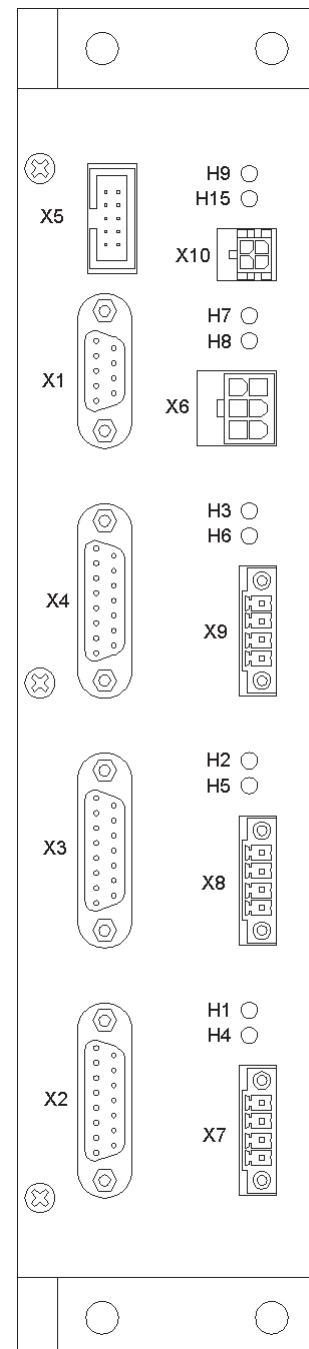

X2, X3, X4 (Drive motor 1 to 3)

PIN	Signal
1	Pulse +
2	Direction +
3G	Gate/Enable +
4	Current control +
5	n.c.
6	n.c.
7	Output + (not assigned)
8	Ready +

PIN	Signal
9	Pulse -
10	Direction -
11	Gate/Enable -
12	Current control -
13	n.c.
14	Output - (not assigned)
15	Ready -

X7, X8, X9 (motor connection motor 1 to 3)

PIN	Signal
1	Coil 1
2	Coil 1
3	Coil 2
4	Coil 2

14.01.06

CAN node A10

The CAN node has following basic setting: address (S200) = 1

Pin assignment

X300 (outputs)

PIN	Signal	PIN	Signal
1	OUT2	19	GND
2	OUT1	20	GND
3	OUT4	21	GND
4	OUT3	22	GND
5	OUT6	23	GND
6	OUT5	24	GND
7	OUT8	25	GND
8	OUT7	26	GND
9	OUT10	27	GND
10	OUT9	28	GND
11	OUT12	29	GND
12	OUT11	30	GND
13	OUT14	31	GND
14	OUT13	32	GND
15	OUT16	33	GND
16	OUT15	34	GND
17			
18			

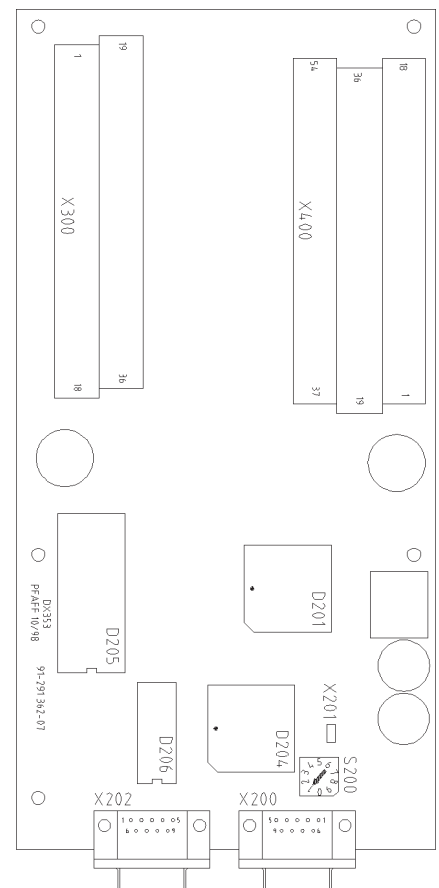

Control unit

X400 (Inputs)

PIN	Signal	PIN	Signal	PIN	Signal
1		19			
2		20			
3	IN1	21	GND	39	24 V
4	IN2	22	GND	40	24 V
5	IN3	23	GND	41	24 V
6	IN4	24	GND	42	24 V
7	IN5	25	GND	43	24 V
8	IN6	26	GND	44	24 V
9	IN7	27	GND	45	24 V
10	IN8	28	GND	46	24 V
11	IN9	29	GND	47	24 V
12	IN10	30	GND	48	24 V
13	IN11	31	GND	49	24 V
14	IN12	32	GND	50	24 V
15	IN13	33	GND	51	24 V
16	IN14	34	GND	52	24 V
17	IN15	35	GND	53	24 V
18	IN16	36	GND	54	24 V

X200 (CAN.Bus)

PIN	Signal	PIN	Signal
1	P8HA +	6	
2	P8HA -	7	
3	D0Ri +	8	DoRi -
4	GND	9	GND
5			

14.02 Error description

If an error occurs on the machine, the current operation is interrupted and an error message sent out. Depending on the gravity of the displayed error, an error-free operation can be achieved by adjusting, checking, different handling etc. If necessary, individual components must be replaced. For many of the error messages, the cause which led to the error is also displayed and will be helpful for error correction (see **Chapter 14.02.01 Example of an error message**).

14.02.01 Example of an error message

Below is an example of an error occurring when an output is activated:

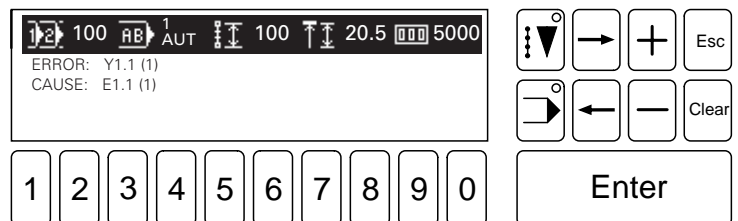

If an error occurs when switching an output, the respective output is displayed with the desired switching state, (0) or (1). (0) means that the output is to be switched off, (1) means that the output is to be switched on. The next line displays the cause which led to the error. In brackets the set condition for an error-free operation is displayed. In the example input E1.1 should therefore be switched on.

14.02.02 Sewing drive error

If an error occurs during an operation with the sewing motor, the operation is interrupted and an error message is displayed.

The error message is generated by the motor controller and appears on the display of the control panel; the index number is hexadecimal.

Number	Error
1	Transfer error
2	Time-out serial interface
3	Check sum error in received data
4	Time-out command
30h	Time-out slave expired (command string incomplete)
31h	Incorrect command code
32h	Framing or parity error
33h	Check sum incorrect
34h	Incorrect data on requests
35h	No parameter programmable (motor is in operation)
36h	Parameter does not exist
37h	Incorrect parameter value
38h	EEPROM is being programmed
39h	Incorrect machine speed
3Ah	Incorrect position
3Bh	Path for guided positioning too short
3Ch	Reset of position counter not possible (motor is in operation)
3Dh	Rotating in TDC after power-on not permissible
3Eh	Synchronization marker not detected
3Fh	Target position < 3 incr. from count position
40h – 4Fh	-
50h	Power monitoring (failure of 2 power half waves)
51h	Malfunction power electronics on initializing
52h	Short circuit in the motor
53h	Power off detected
54h	Malfunction in power electronics in operation
55h	No increments
56h	Motor blocks
57h	Commutating signal generator plug missing
58h	Increment signal generator plug missing
59h	Motor not running properly (set speed not achieved)
5Ah	-
5Bh	Feedback control algorithm is inhibited
5Ch – 69h	-
6Ah	EEPROM not programmable
6Bh	EEPROM missing
6Ch	Master Reset carried out
6Dh	-
6Eh	Remaining path for path-monitored, guided delay ramps too small
6Fh	Slave has received 5 garbled messages in a row
70h	Time monitoring system expired
71h – FFh	-

14.02.03 Errors – Stepping motor drive

If problems occur with the stepping motor drive during the operation, an error might have occurred in the stepping motor controller.

The error message is indicated by LEDs on the stepping motor controller.

LED	Meaning
H9 (red)	Temperature too high in end phase
H15 (red)	End phase ready
H7 (red)	80 V supply > 88 V
H8 (red)	80 V supply < 36 V
H3 (green)	motor 3 ready
H6 (red)	excess current motor 3
H2 (green)	motor 2 ready
H5 (red)	excess current motor 2
H1 (green)	motor 1 ready
H4 (red)	excess current motor 1

Additional problems

Problem	Cause	Correction
no LED are lit	- supply voltage missing	check supply voltage
	- supply voltage incorrect	connect properly
LED motor ready (H1, H2, H3) is not lit up	- signal input Enable not active	set input to active
motor is not rotating and does not have a holding torque	- signal input current controller active	set input to inactive
	- motor connected incorrectly	connect properly
motor is not rotating but does have a holding torque	- signal input pulse	correct timing and voltage level
motor is rotating unevenly	- signal inputs pulse and direction	correct timing and voltage level
	- overload	check load conditions
	- motor defective	replace motor
motor is rotating in the wrong direction	- motor phases connected the wrong way round	connect motor phases properly
	- signal input direction incorrectly set	correct rotary direction
motor has too little momentum current	- motor phase current incorrectly set	choose the correct phase

14.02.04 Error during stitch generation

If an error occurs during the calculation of the stitch data, operation is interrupted and an error message displayed. The error message appears in clear text and if necessary with a number in brackets. This number indicates the section, where the error has occurred.









Additionally errors may occur which have not been assigned a special text.

The meaning of the error number is shown in the following table:

Number	Error
0	No error
1	Wrong machine code in geometrical data record
2	Section clamp or section obstacle is missing or in the wrong place
3	Increment too large
4	Program end without trimming
5	Stitch length inadmissible
6	Wrong element in the geometrical record data
7	Fast slew although machine sewing
8	Stitch length inadmissible (line)
9	Stitch length inadmissible (circle)
10	Circle point = circle end point
11	Division by 0
12	Stitch length inadmissible (curve)
13	No coordinate section in front of the curve point
14	Sewing area exceeded
15	Curve without end point
16	Machine buffer functions full
17	Start sewing command in the loading position program
18	Wrong curve point
19	Wrong curve point
20	Wrong curve point
21	Wrong curve point
22	Stitch length not initialized
23	Load position program not finished
24	Stitch width command in the loading position program
25	Value not permissible for section stitch direction
26	Trimming command, although thread has been trimmed
27	Start sewing command, although machine is sewing
28	Trimming command in the Sewing-off area
29	Sewing-off command, although thread has been trimmed
30	Trimming command immediately after Start Sewing command

14.03 Tables

14.03.01 Tables for lock/release functions

Code number	Function
0	 Program number selection
1	 Sequence program number selection
2	 Modify selected program
91	 Create program
3	DART 1
4	DART 2
5	PLEAT 1
6	PLEAT 2
7	FREE PROGRAM
92	 Create/modify free program
8	 Seam parameter
9	STARTTACK
10	STITCH CONDENSING SEAM START
11	ENDTACK
12	STITCH CONDENSING SEAM END
13	ANGLE SEAM END
14	BASTING STITCH
15	 Bobbin thread functions
16	RESET STITCH COUNTER
17	BOBBIN THREAD PRESELECT
18	 Sewing head functions
19	MAXIMUM SPEED
20	SPEED TACK / REDUCTION
21	SPEED BASTING STITCH
22	INTERMITTENT STOP
23	MAX: DEPTH CORRECTION

Code number	Function
24	 Input menu
25	PROGRAM MANAGEMENT
26	DIRECTORY
27	DIRECTORY OF MEMORY
28	DIRECTORY OF DISK
29	READ/WRITE PROGRAM
30	READ ONE PROGRAM FROM DISK
31	READ ALL PROGRAMS FROM DISK
32	WRITE ONE PROGRAM TO DISK
33	WRITE ALL PROGRAMS TO DISK
34	DELETE PROGRAMS
35	DELETE ONE PROGRAM IN MEMORY
36	DELETE ALL PROGRAMS IN MEMORY
37	DELETE ONE PROGRAM ON DISK
38	DELETE ALL PROGRAMS ON DISK
39	FORMAT DISK
40	COUNTERS
41	RESET PIECE COUNTER
42	THREAD MONITOR
43	SUPPRESSED STITCHES NEEDLE THREAD MONITOR
44	REACTION TIME THREAD MONITOR
45	NUMBER OF SLOW START-STITCHES
46	CARRIAGE START (NIS)
47	START FOR THREAD TRIMMING
48	SWITCH FUNCTIONS
49	THREAD MONITOR
50	NEEDLE THREAD MONITOR
51	BOBBIN THREAD MONITOR
52	LANGUAGE SELECTION
53	GERMAN
54	ENGLISH
55	FRENCH
56	SPANISH
57	TURKISH
58	FREE
59	LOCK/RELEASE FUNCTIONS
60	OTHER FUNCTIONS
61	MOVE TAKE-OVER
62	THREADING POSITION

Control unit

Code number	Function
63	TIMES
64	AIR BLAST TIME
65	SERVICE
66	SEWING DRIVE FUNCTIONS
67	TURN SEWING MOTOR
68	THREAD TRIMMING PROCEDURE
69	CUTTING SPEED – PRESELECT
70	STEPPING MOTOR FUNCTIONS
71	STEPPING MOTOR 1
72	STEPPING MOTOR 2
73	STEPPING MOTOR 3
74	DISPLAY INPUTS/OUTPUTS
75	ADJUST ZERO POINT
76	CARRIAGE POSITION
77	DEPTH
78	NEEDLE POSITION
79	CORRECTION VALUE START POINT
80	ADJUSTMENTS READ/WRITE
81	READ MACHINE DATA FROM DISK
82	WRITE MACHINE DATA TO DISK
83	READ CONFIGURATION/ZERO POINTS FROM DISK
84	WRITE CONFIGURATION/ZERO POINTS TO DISK
85	OTHER FUNCTIONS
86	CARRY OUT COLD START
87	DISPLAY SOFTWARE STATUS
88	CONTRAST SETTING OF DISPLAY
89	CHANGE CODE NUMBER
90	INSTALL OPERATING SYSTEM

14.03.02 Machine data table (MDAT)

The following input functions are stored:

Program selection:	Program type (0 = standard/ 1 – sequence programs) Program number Sequence program number Index of active program (for sequences) Index of next program (for sequences) Array of program sequences Type of change to next sequence
Seam parameter:	Starttack Stitch condensing seam start End tack Stitch condensing seam end Angle seam end Basting stitch
Bobbin thread functions:	Bobbin thread preselect
Sewing head functions:	Maximum speed Speed tack / reduction Speed basting stitch Intermittent stop Maximum depth correction Array of depth correction
Counters:	Suppressed stitches needle thread monitor Reaction time needle thread monitor Slow start stitches Carriage start NIS Start for thread trimming
Switch functions:	Needle thread monitor Bobbin thread monitor Language selection Lock/release functions Move take-over Threading position
Times:	Air blast time
Service:	Cutting speed Code number

Control unit

14.03.03 Table of outputs

Nodes A10/X300

Output	Denomination		Index number
OUT1	Y1.1	Loading table backwards	0
OUT2	Y1.2	Loading table forwards	1
OUT3	Y2	Suction on	2
OUT4	Y3	Needle strip down	3
OUT5	Y4	Pressure bar down	4
OUT6	Y5	Sewing foot up	5
OUT7	Y6	Thread tension on	6
OUT8	Y7	Thread trimmer on	7
OUT9	Y8	Air blast on	8
OUT10	Y9.1	Material clamp down (optional)	9
OUT11	Y9.2	Material clamp up (optional)	10
OUT12	OUT1	Programmable output 1	11
OUT13	OUT 2	Programmable output 2	12
OUT14			13
OUT15			14
OUT16			15

14.03.04 Table of inputs

Nodes A10/X400

Input	Denomination	
IN1	IN1	programmable input 1
IN2	IN2	programmable input 2
IN3	E1.1	loading table back
IN4	E1.2	loading table forward
IN5	E1.3	loading table at centre (pushed back)
IN6	E5	sewing foot raised
IN7	SMXNULL	zero position SMX
IN8	SMYNULL	zero position SMY
IN9	SMTNULL	zero position SM material take-over (depth)
IN10	THERR	needle thread error
IN11	FKEY	key for secured functions
IN12	SMXLIMIT	impermissible position for SMX
IN13	E10	Bobbin flap closed
IN14	E11	U-bar attached
IN15		
IN16		

Reference list for the circuit diagrams

A10	CAN-nodes (DX 353)
A20	Controller BS 3
A21	Printed circuit board (MOPS 586)
A22	Quick controller (Q201MS)
A23	Board (FLOPPY STOP)
A24	Evaluation thread monitor
A25	Sensor thread monitor (MSF02)
A26	Control panel Vers. 3.0
A30	Power supply unit BS 3
A40	Controller SM-end phase
A50	Floppy-LW HD
E1.1	Initiator – loading table rear
E1.2	Initiator – loading table front
E1.3	Initiator – loading table centre
E5	Initiator – presser foot raised
E10	Switch bobbin latch closed
E11	Initiator – recognition U-bar attached
F1, F2	Fuse 6.3x32 10A inert
M1	Stepping motor X
M2	Stepping motor Y
M3	Stepping motor T
M4	Sewing motor Ministop MS2 QE 3760

Referenzliste

Q1	Main switch 71-111 003-07
SMXNULL	Initiator – zero position stepping motor X
SMYNULL	Initiator – zero position stepping motor Y
SMTNULL	Initiator – zero position stepping material takeover
SMXLIMIT	Initiator – impermissible position for stepping motor X
T1	Transformer 230V
Y1.1	Valve – loading table backwards
Y1.2	Valve – loading table forwards
Y2	Valve – suction on
Y3	Valve – needle strip off
Y4	Valve – workholder bar off
Y5	Valve – sewing foot on
Y6	Valve – thread tension on
Y7	Valve – thread trimming on
Y8	Valve – air blast on
Y9	Valve – air blast sewing foot on
Z1	Interference filter (10 VSK 1)

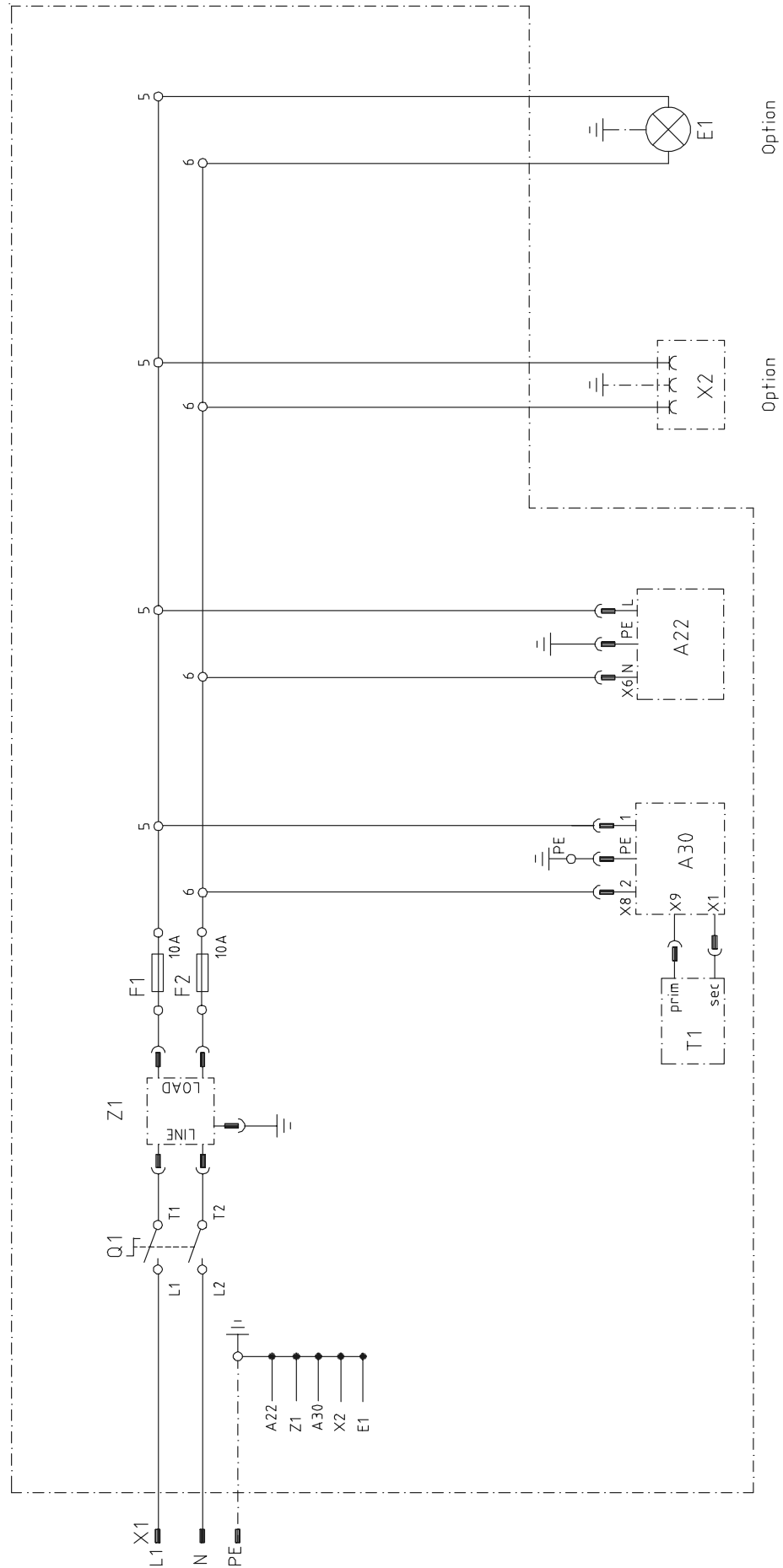

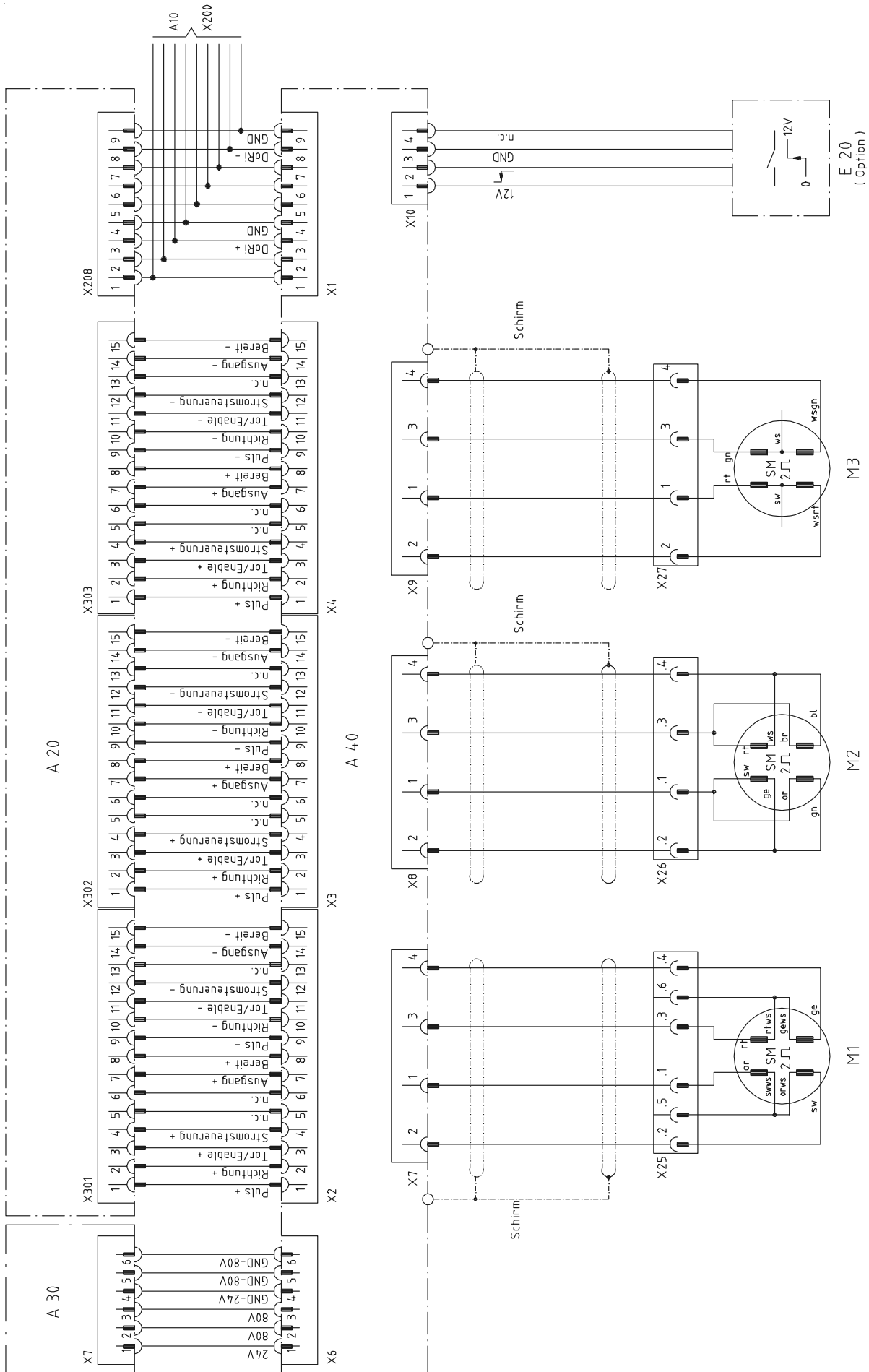

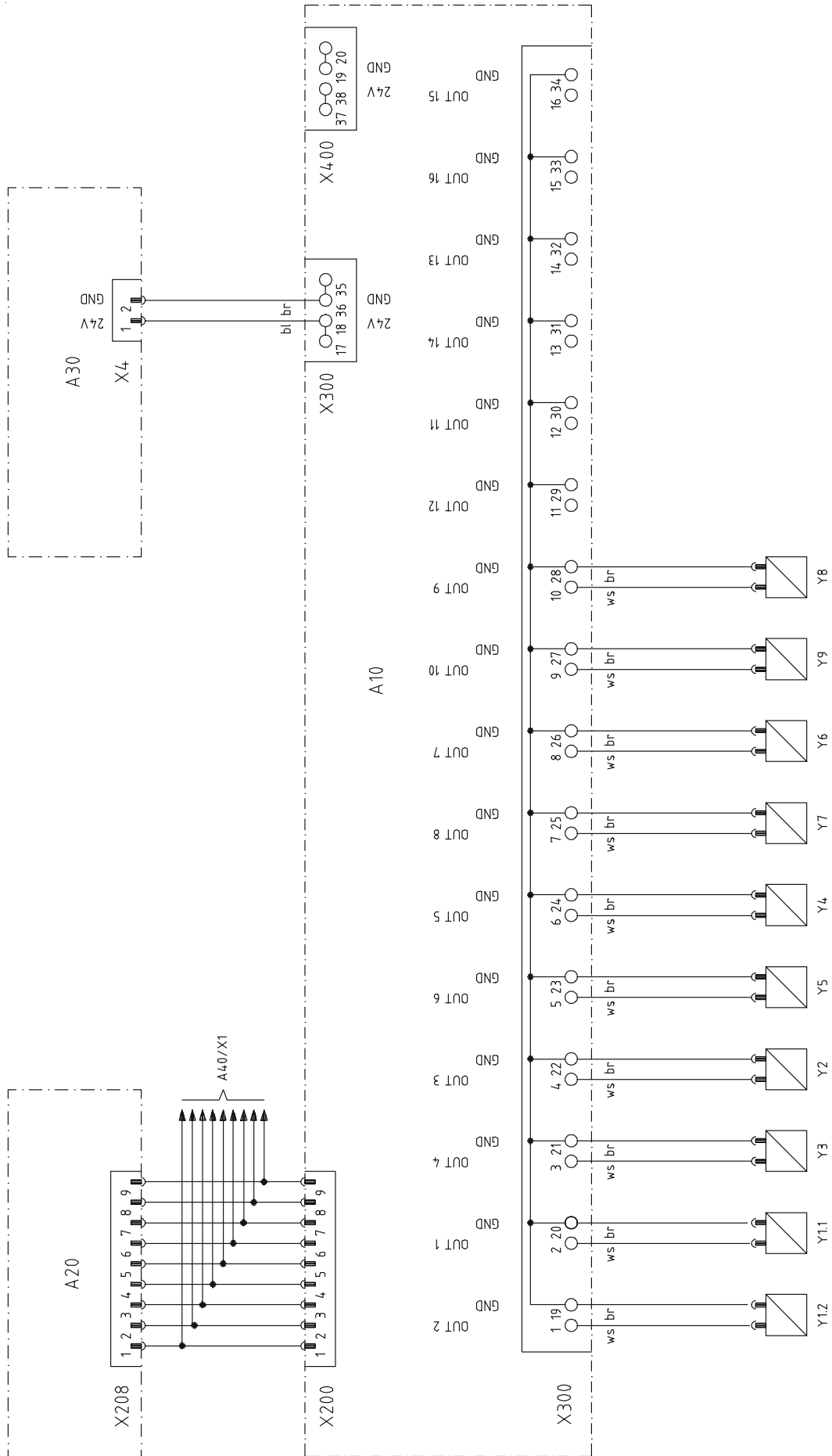

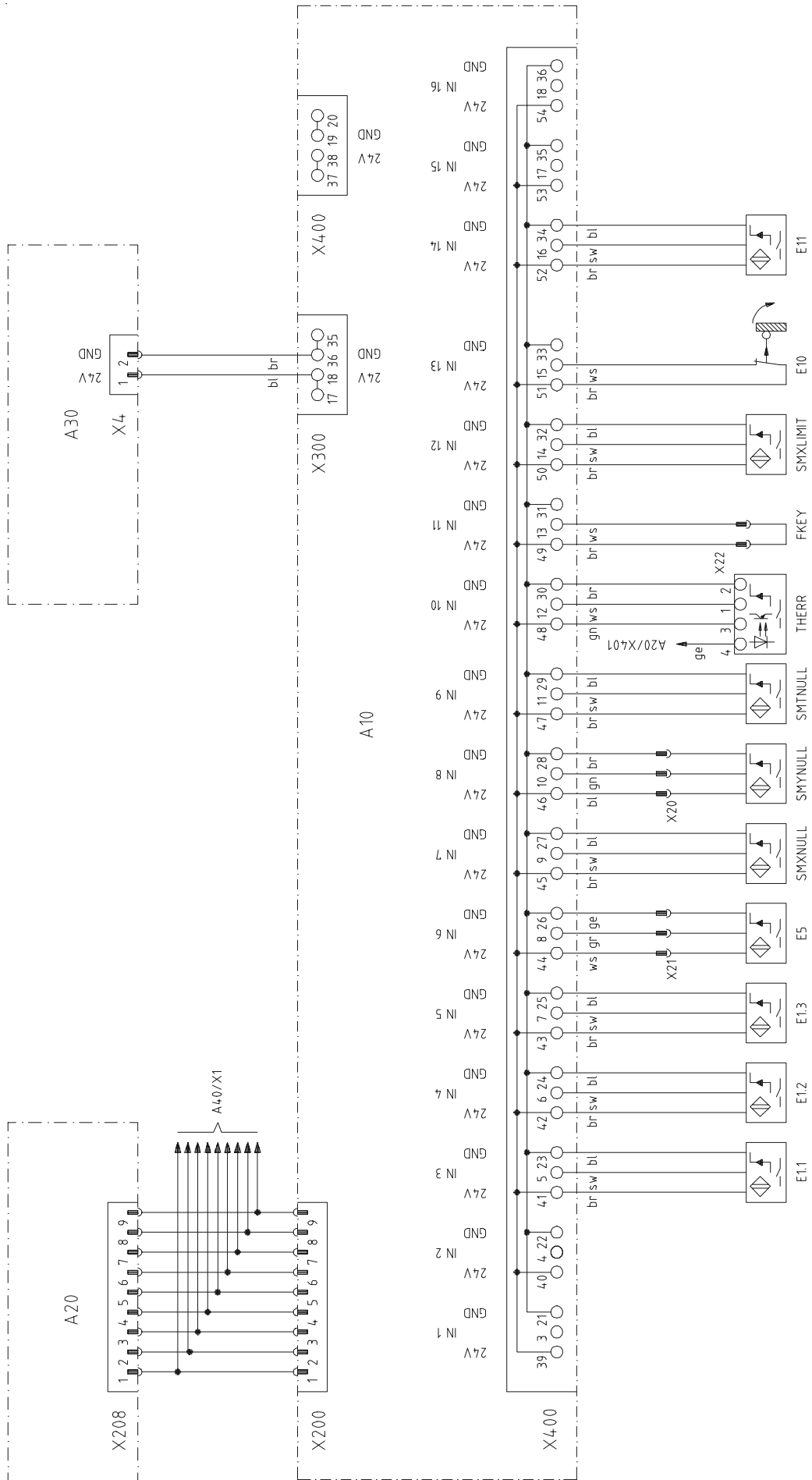

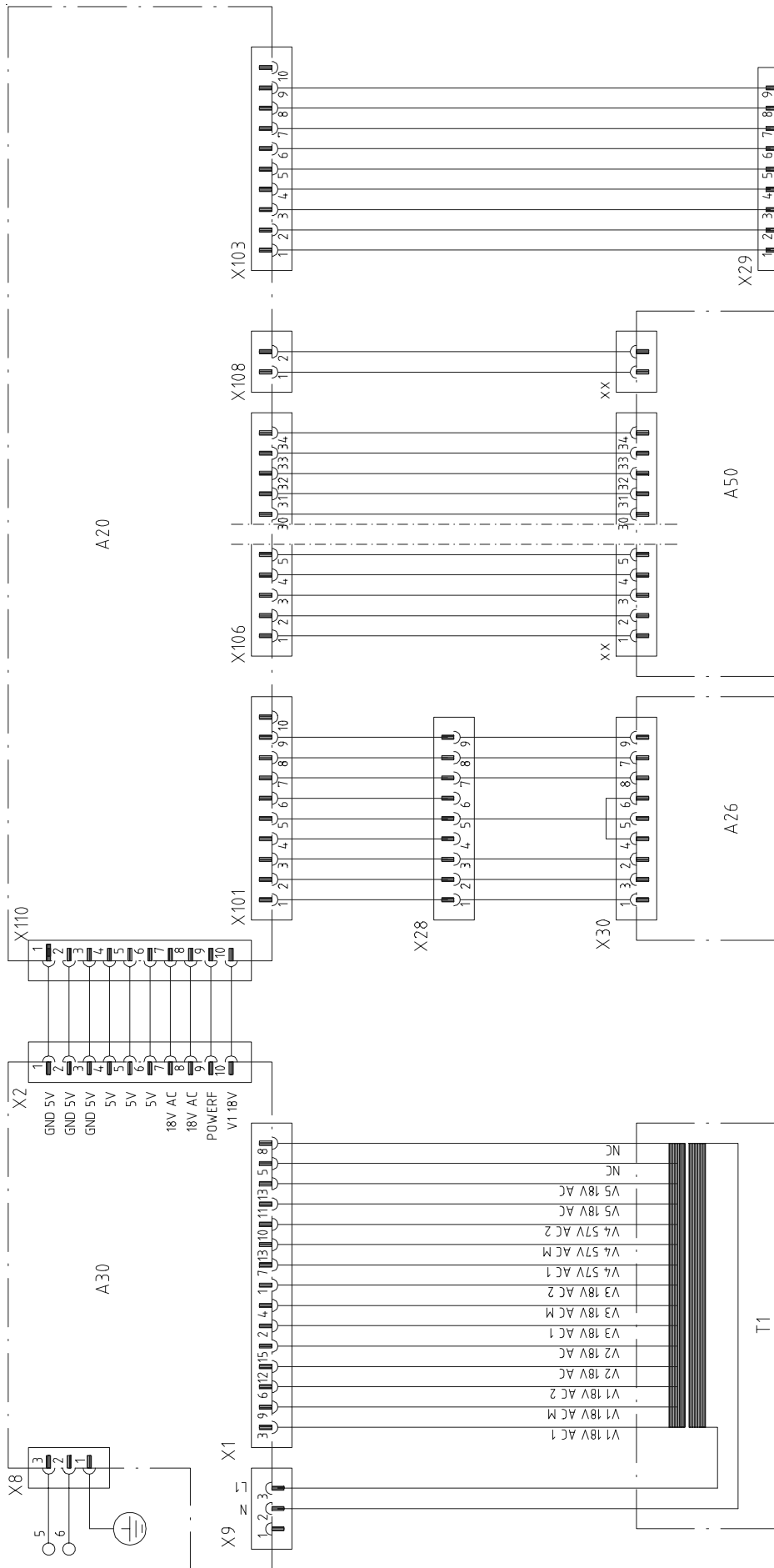

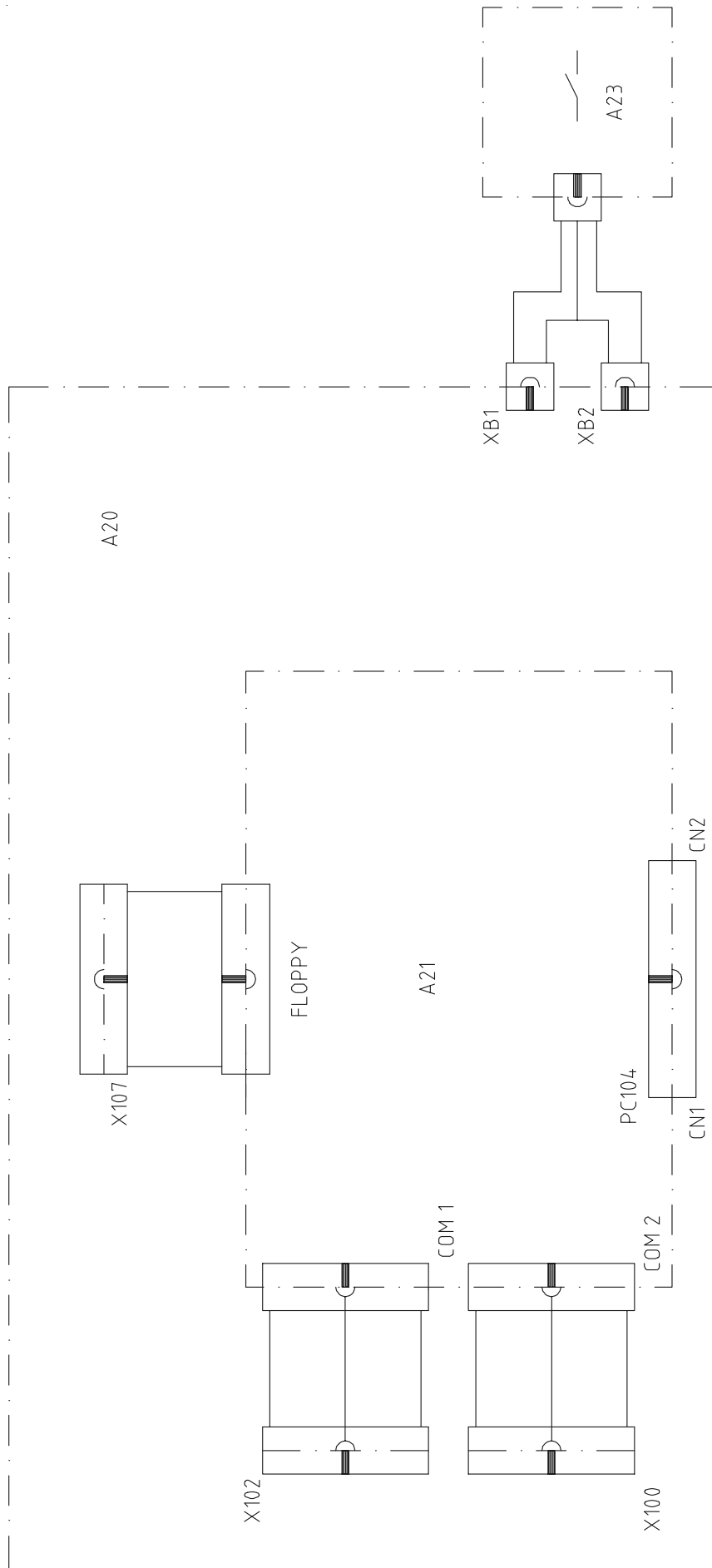

PFAFF

PFAFF Industrie Maschinen AG

Postfach 3020
D-67653 Kaiserslautern

Königstr. 154
D-67655 Kaiserslautern

Telefon: (0631) 200-0
Telefax: (0631) 17202
E-Mail: info@pfaff-industrial.com

Gedruckt in der BRD
Printed in Germany
Imprimé en R.F.A.
Impreso en la R.F.A.