

PFAFF

3834^{-4/11}_{-4/21}

Instruction Manual

This instruction manual applies to machines from the following serial numbers onwards:

482319 →

The reprinting, copying or translation of PFAFF Instruction Manuals, whether in whole or in part, is only permitted with our previous authorization and with written reference to the source.

PFAFF Industrie Maschinen AG

Postfach 3020

D-67653 Kaiserslautern

Königstr. 154

D-67655 Kaiserslautern

Editing / Illustrations

HAAS-Publikationen GmbH

D-53840 Troisdorf

| | | Chapter - Page |
|-------------|---|----------------|
| | Contents | |
| 1 | Safety | 1 - 1 |
| 1.01 | Directives | 1 - 1 |
| 1.02 | General notes on safety | 1 - 1 |
| 1.03 | Safety symbols | 1 - 2 |
| 1.04 | Important points for the user | 1 - 2 |
| 1.05 | Operating and specialist personnel | 1 - 3 |
| 1.05.01 | Operating personnel | 1 - 3 |
| 1.05.02 | Specialist personnel | 1 - 3 |
| 1.06 | Danger | 1 - 4 |
| 2 | Proper use | 2 - 1 |
| 3 | Specifications | 3 - 1 |
| 3.01 | PFAFF 3834-4/11; -4/21 | 3 - 1 |
| 3.02 | Model, needle and thread | 3 - 1 |
| 4 | Disposal of the machine | 4 - 1 |
| 5 | Transport, packaging and storage | 5 - 1 |
| 5.01 | Transport to the customer | 5 - 1 |
| 5.02 | Transport within the customer's premises | 5 - 1 |
| 5.03 | Disposal of the packaging | 5 - 1 |
| 5.04 | Storage | 5 - 1 |
| 6 | Explanation of the symbols | 6 - 1 |
| 7 | Controls | 7 - 1 |
| 7.01 | On/off switch | 7 - 1 |
| 7.02 | Keys on the machine head | 7 - 1 |
| 7.03 | Pedal | 7 - 2 |
| 7.04 | Knee switch | 7 - 2 |
| 7.05 | Lever for lifting the roller presser | 7 - 3 |
| 7.06 | Control panel | 7 - 4 |
| 7.06.01 | Display | 7 - 4 |
| 7.06.02 | Operation-mode keys | 7 - 5 |
| 7.06.03 | Function keys | 7 - 5 |
| 7.06.04 | Number keys | 7 - 5 |
| 8 | Mounting and commissioning the machine | 8 - 1 |
| 8.01 | Mounting | 8 - 1 |
| 8.01.01 | Adjusting the table-top height | 8 - 1 |
| 8.01.02 | Adjusting the V-belt tension | 8 - 2 |
| 8.01.03 | Mounting the upper V-belt guard | 8 - 2 |
| 8.01.04 | Mounting the lower V-belt guard | 8 - 3 |
| 8.01.05 | Mounting the synchronizer | 8 - 3 |
| 8.01.06 | Mounting the spool holder | 8 - 4 |
| 8.02 | Commissioning the machine | 8 - 4 |
| 8.03 | Turning the machine on/off | 8 - 4 |

| | Contents | Chapter - Page |
|--------------|---|----------------|
| 9 | Preparation | 9 - 1 |
| 9.01 | Inserting the needle | 9 - 1 |
| 9.02 | Winding the bobbin thread, adjusting the thread tension | 9 - 2 |
| 9.03 | Removing / Inserting the bobbin case | 9 - 3 |
| 9.04 | Threading the bobbin case / Adjusting the bobbin thread tension | 9 - 3 |
| 9.05 | Threading the needle thread / Adjusting the needle thread tension | 9 - 4 |
| 9.06 | Adjusting the stitch length | 9 - 5 |
| 9.07 | Selecting a language | 9 - 6 |
| 10 | Sewing | 10 - 1 |
| 10.01 | Manual sewing | 10 - 1 |
| 10.02 | Manual application of fullness | 10 - 2 |
| 10.03 | Changing the maximum fullness amount. | 10 - 3 |
| 10.04 | Sewing with the fixed programs | 10 - 4 |
| 10.05 | Programed sewing | 10 - 5 |
| 10.06 | Program interruption | 10 - 6 |
| 10.07 | Error messages | 10 - 7 |
| 11 | Programing | 11 - 1 |
| 11.01 | Symbols in the status bar | 11 - 1 |
| 11.02 | Symbols in the text and graphic fields | 11 - 2 |
| 11.02.01 | Text and graphic fields in the SEWING mode | 11 - 2 |
| 11.02.02 | Text and graphics fields in the INPUT mode | 11 - 3 |
| 11.03 | Symbols in the pictogram bar | 11 - 4 |
| 11.04 | Summary of the functions in SEWING mode | 11 - 5 |
| 11.05 | Summary of the functions in INPUT mode | 11 - 6 |
| 11.06 | Summary of the functions in program administration | 11 - 7 |
| 11.07 | Summary of the functions in the input menu | 11 - 7 |
| 11.08 | Summary of the service functions | 11 - 8 |
| 11.09 | Selection of functions from menu levels | 11 - 8 |
| 11.10 | Creating seam programs | 11 - 10 |
| 11.10.01 | Altering fixed programs | 11 - 10 |
| 11.10.02 | Programing | 11 - 12 |
| 11.10.03 | Teach In | 11 - 14 |
| 11.11 | Selecting the size | 11 - 16 |
| 11.11.01 | Selecting the basic size in the INPUT mode | 11 - 16 |
| 11.11.02 | Selecting the size in the SEWING mode | 11 - 17 |
| 11.12 | Programing examples | 11 - 18 |
| 11.12.01 | Example for programing a seam | 11 - 18 |
| 11.12.02 | Example of Teach In programing | 11 - 23 |
| 12 | Care and maintenance | 12 - 1 |
| 12.01 | Cleaning | 12 - 1 |
| 12.02 | Lubricating the hook | 12 - 2 |
| 12.03 | Filling the oil reservoir | 12 - 2 |
| 12.04 | Cleaning the air filter on the control box | 12 - 3 |
| 12.05 | Lubricating the bevel gears | 12 - 3 |

| | Contents | Chapter - Page |
|--------------|---|----------------|
| 13 | Adjustment | 13 - 1 |
| 13.01 | Notes on adjusting | 13 - 1 |
| 13.02 | Tools, gauges and other accessories for adjusting | 13 - 1 |
| 13.03 | Abbreviations | 13 - 1 |
| 13.04 | Adjusting the basic machine | 13 - 2 |
| 13.04.01 | Adjusting the synchronizer | 13 - 2 |
| 13.04.02 | Positioning the needle in the direction of sewing | 13 - 4 |
| 13.04.03 | Positioning the needle across the direction of sewing | 13 - 5 |
| 13.04.04 | Preadjusting the needle height | 13 - 6 |
| 13.04.05 | Needle rise, hook-to-needle clearance, needle height and needle guard | 13 - 7 |
| 13.04.06 | Bobbin case opener height | 13 - 9 |
| 13.04.07 | Bobbin case opener stroke | 13 - 10 |
| 13.04.08 | Feed wheel height | 13 - 11 |
| 13.04.09 | Clearance between the roller presser or band feed and the feed wheel | 13 - 12 |
| 13.04.10 | Roller presser (3834-4/11) | 13 - 13 |
| 13.04.11 | Band feed (3834-4/21) | 13 - 14 |
| 13.04.12 | Changing the band (3834-4/21) | 13 - 15 |
| 13.04.13 | Automatic presser-foot lifter | 13 - 16 |
| 13.04.14 | Holding-down clamp | 13 - 17 |
| 13.04.15 | Tension release | 13 - 18 |
| 13.04.16 | Thread check spring | 13 - 19 |
| 13.04.17 | Bobbin winder | 13 - 20 |
| 13.04.18 | Roller presser pressure | 13 - 21 |
| 13.05 | Adjusting the edge trimmer -900/53 | 13 - 22 |
| 13.05.01 | Removing the scissors | 13 - 22 |
| 13.05.02 | Control cam to bobbin opener and tripping lever | 13 - 23 |
| 13.05.03 | Radial position of the tripping lever | 13 - 24 |
| 13.05.04 | Engaging solenoid | 13 - 25 |
| 13.05.05 | Scissor drive lever | 13 - 26 |
| 13.05.06 | Adjusting the control cam with the adjustment gauge in relation to the bobbin opener and the scissor | 13 - 27 |
| 13.05.07 | Radial position of the control cam in relation to the bobbin opener | 13 - 28 |
| 13.05.08 | Scissor tripping-lever in relation to the control cam of the scissor | 13 - 29 |
| 13.05.09 | Control cam in relation to scissor | 13 - 30 |
| 13.05.10 | Scissor return lever | 13 - 31 |
| 13.05.11 | Scissor return control | 13 - 32 |
| 13.05.12 | Installing the scissor | 13 - 33 |
| 13.05.13 | Eccentric sleeve | 13 - 34 |
| 13.05.14 | Scissor drive bar | 13 - 35 |
| 13.05.15 | Scissor function test | 13 - 36 |
| 13.06 | Tension control | 13 - 37 |
| 13.07 | Parameter adjustments | 13 - 40 |
| 13.07.01 | Adjusting positions | 13 - 40 |
| 13.07.02 | Adjusting the counter | 13 - 41 |
| 13.07.03 | Adjusting speeds | 13 - 41 |

1 Safety

1.01 Directives

This machine is constructed in accordance with the European regulations contained in the conformity and manufacturer's declarations.

In addition to this Instruction Manual, also observe all generally accepted, statutory and other regulations and legal requirements and all valid environmental protection regulations!

The regionally valid regulations of the social insurance society for occupational accidents or other supervisory organizations are to be strictly adhered to!

1.02 General notes on safety

- This machine may only be operated by adequately trained operators and only after having completely read and understood the Instruction Manual!
- All Notes on Safety and Instruction Manuals of the motor manufacturer are to be read before operating the machine!
- The danger and safety instructions on the machine itself are to be followed!
- This machine may only be used for the purpose for which it is intended and may not be operated without its safety devices. All safety regulations relevant to its operation are to be adhered to.
- When exchanging sewing tools (e.g. needle, roller presser, needle plate and bobbin), when threading the machine, when leaving the machine unattended and during maintenance work, the machine is to be separated from the power supply by switching off the On/Off switch or by removing the plug from the mains!
- Everyday maintenance work is only to be carried out by appropriately trained personnel!
- Repairs and special maintenance work may only be carried out by qualified service staff or appropriately trained personnel!
- Work on electrical equipment may only be carried out by appropriately trained personnel!
- Work is not permitted on parts and equipment which are connected to the power supply! The only exceptions to this rule are found in the regulations EN 50110.
- Modifications and alterations to the machine may only be carried out under observance of all the relevant safety regulations!

- Only spare parts which have been approved by us are to be used for repairs!
We expressly point out that any replacement parts or accessories which are not supplied by us have not been tested and approved by us. The installation and/or use of any such products can lead to negative changes in the structural characteristics of the machine. We are not liable for any damage which may be caused by non-original parts.

1.03 Safety symbols



Danger!
Points to be observed.



Danger of injury for operating and specialist personnel!



Caution

Do not operate without finger guard and safety devices. Before threading, changing bobbin and needle, cleaning etc. switch off main switch.

1.04 Important points for the user

- This Instruction Manual is an integral part of the machine and must be available to the operating personnel at all times.
The Instruction Manual must be read before operating the machine for the first time.
- The operating and specialist personnel is to be instructed as to the safety equipment of the machine and regarding safe work methods.
- It is the duty of the user to only operate the machine in perfect running order.
- It is the obligation of the user to ensure that none of the safety mechanisms are removed or deactivated.
- It is the obligation of the user to ensure that only authorized persons operate and work on the machine.

Further information can be obtained from your PFAFF agent.

1.05 Operating and specialist personnel

1.05.01 Operating personnel

Operating personnel are persons responsible for the equipping, operating and cleaning of the machine as well as for taking care of problems arising in the sewing area.

The operating personnel is required to observe the following points and must:

- always observe the Notes on Safety in the Instruction Manual!
- never use any working methods which could adversely affect the safety of the machine!
- not wear loose-fitting clothing or jewelery such as chains or rings!
- also ensure that only authorized persons have access to the potentially dangerous area around the machine!
- always immediately report to the person responsible any changes in the machine which may limit its safety!

1.05.02 Specialist personnel

Specialist personnel are persons with a specialist education in the fields of electricians, electronics and mechanics. They are responsible for the lubrication, maintenance, repair and adjustment of the machine.

The specialist personnel is obliged to observe the following points and must:

- always observe the Notes on Safety in the Instruction Manual!
- switch off the On/Off switch before carrying out adjustments or repairs, and ensure that it cannot be switched on again unintentionally!
- never work on parts which are still connected to the power supply! Exceptions are explained in the regulations EN 50110.
- replace the protective coverings after all repairs or maintenance work and close the electrical control box after all repairs or maintenance work!

1.06

Danger



A working area of **1 meter** is to be kept free both in front of and behind the machine while it is in operation so that it is always easily accessible.



Never reach into the sewing area while sewing!
Danger of injury by the needle!



Never leave objects on the table while adjusting the machine settings!
Objects can become trapped or be slung away!
Danger of injury!

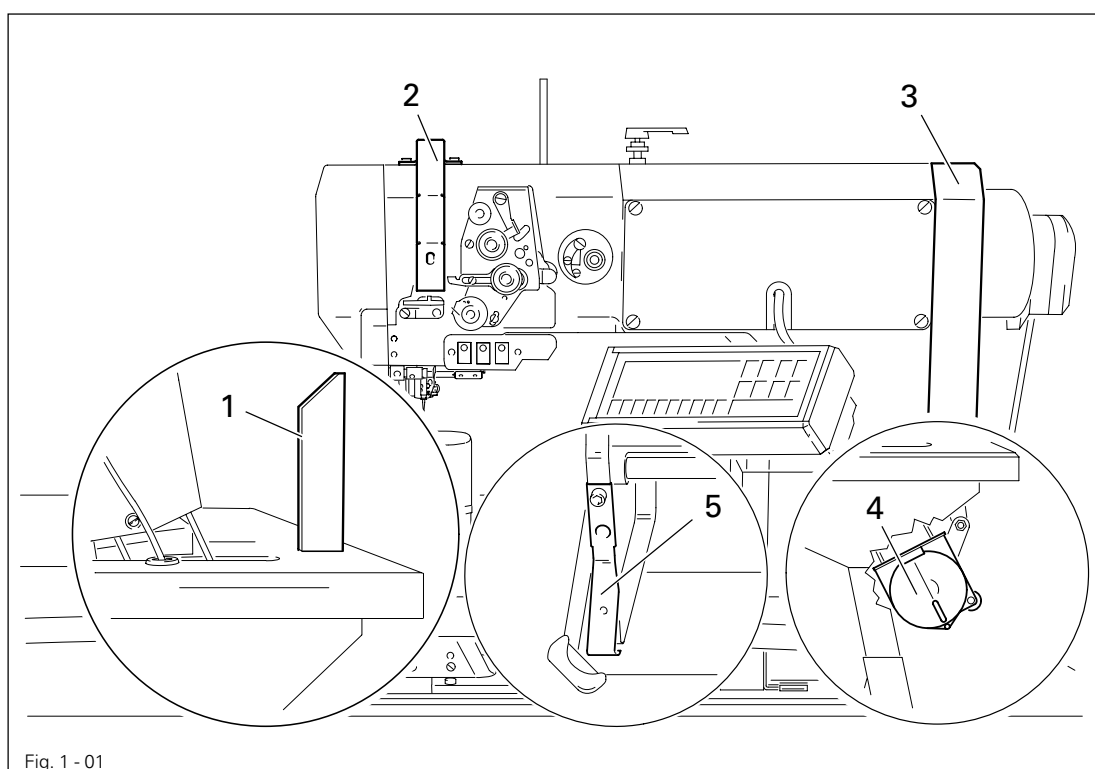

Fig. 1 - 01



Do not operate the machine without support **1!**
Danger due to top-heavy sewing head!
Machine can tip over backwards when tilted!



Do not operate the machine without its take-up lever guard **2!**
Danger of injury due to the motion of the take-up lever!



Do not operate the machine without the belt guards **3 and 4!**
Danger of injury due to the rotating V-belts!



Do not operate the machine without tilt lock **5!**
Danger of crushing between sewing head and table!

2 Proper use

The PFAFF 3834-4/11 is a high-speed, single needle, postbed sewing machine (post to the right of the needle) with forwards and reverse feeding feed-wheel and roller presser.

The PFAFF 3834-4/21 is a high-speed, single needle, postbed sewing machine (post to the right of the needle) with forwards and reverse feeding feed-wheel and band feed.

This machine is used for sewing lockstitch seams in the clothing industry.



Any and all uses of this machine which have not been approved of by the manufacturer are considered to be inappropriate! The manufacturer cannot be held liable for any damage caused by the inappropriate use of the machine! The appropriate use of the machine includes the observance of all operational, adjustment, maintenance and repair measures required by the manufacturer!

3 Specifications

3.01 PFAFF 3834-4/11 ▲
PFAFF 3834-4/21 ▲

Stitch type: 301 (lockstitch)

Handwheel eff. dia.: 65 mm

Fabric clearance: 9 mm

Clearance width: 245 mm

Clearance height: 115 mm

Post height: 180 mm

Dimensions of sewing head:

Length: approx. 615 mm

Width: approx. 240 mm

Height (above table): approx. 500 mm

Bedplate: 518 x 177 mm

Max. speed: 3200 spm ♦

Electrical data:

Operating voltage: 230 V ± 10%, 50/60 Hz

Max. output: 1.2 kVA

Fuse protection: 1 x 16 A, delayed action

Software: Version 79-0011 0200/010

Noise data:

Emission sound level at the workplace at a speed of 2700 spm: 80 dB(A)■

(Noise measurement in acc. with DIN 45 635-48-A-1, ISO 11204, ISO 3744, ISO 4871)

Net weight of machine head: approx. 61 kg

Gross weight of machine head: approx. 71 kg

▲ Subject to alternation

♦ Varies according to material, work process and stitch length

■ $K_{pA} = 2,5$ dB

3.02 Model, needle and thread

Type of model: A

Needle system: 134-35 R

Needle thickness in 1/100 mm: 70

Thread thickness max. synthetic *: 60 - 60

* or comparable thicknesses of other thread types

4 Disposal of machine

- The proper disposal of the machine is the responsibility of the customer.
- The materials used in the machines are steel, aluminium, brass and various plastics. The electrical equipment consists of plastics and copper.
- The machine is to be disposed of in accordance with the locally valid environmental protection regulations. If necessary, a specialist is to be commissioned.



Special care is to be taken that parts soiled with lubricants are separately disposed of in accordance with the locally valid pollution control regulations!

5 Transport, packaging and storage

5.01 Transport to the customer's premises

Within Germany, complete machines (with table and motor) are delivered without packaging. Machines which are to be exported are packaged.

5.02 Transport within the customer's premises

The manufacturer bears no liability for transport within the customer's premises or to the individual locations of use. Always ensure that the machine is only transported upright.

5.03 Disposal of the packaging

The packaging of these machines consists of paper, cardboard and VCE fiber. The proper disposal of the packaging is the responsibility of the customer.

5.04 Storage

The machine can be stored for up to 6 months if not in use. During this time it should be protected from dust and moisture.

For longer storage the individual parts of the machine, especially the moving parts, should be protected against corrosion, e.g. by a film of oil.

Explanation of the symbols

6 Explanation of the symbols

In the following section of this Instruction Manual, certain tasks or important pieces of information are accentuated by symbols.

The symbols used have the following meanings:



Note, information



Cleaning, care



Lubrication, greasing

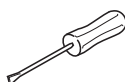

Servicing, repairing, adjustment, maintenance
(only to be carried out by specialist personnel)

7 Controls

7.01 On/Off switch

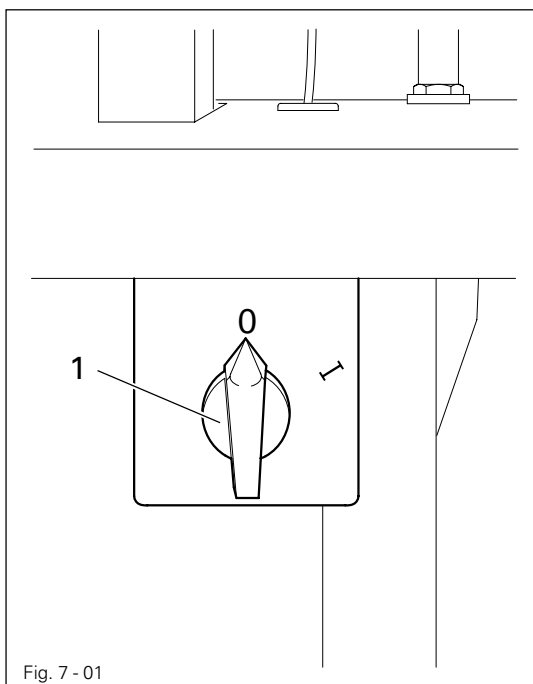

Fig. 7 - 01

- Turn the machine on/off by turning On/Off switch 1.

7.02 Keys on the machine head

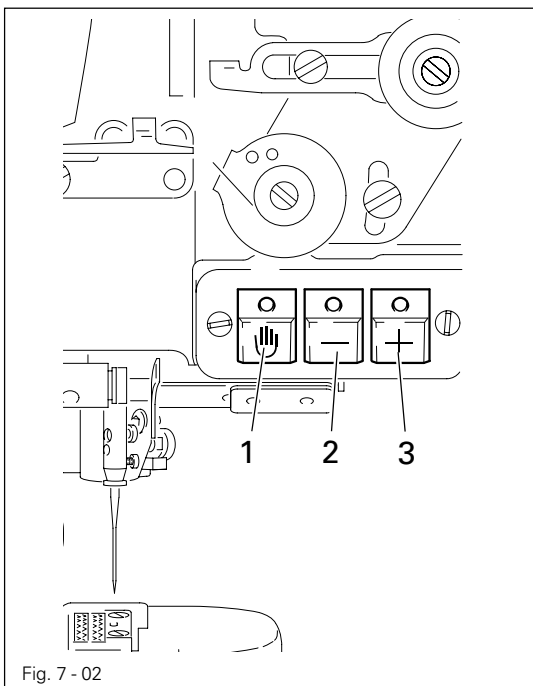
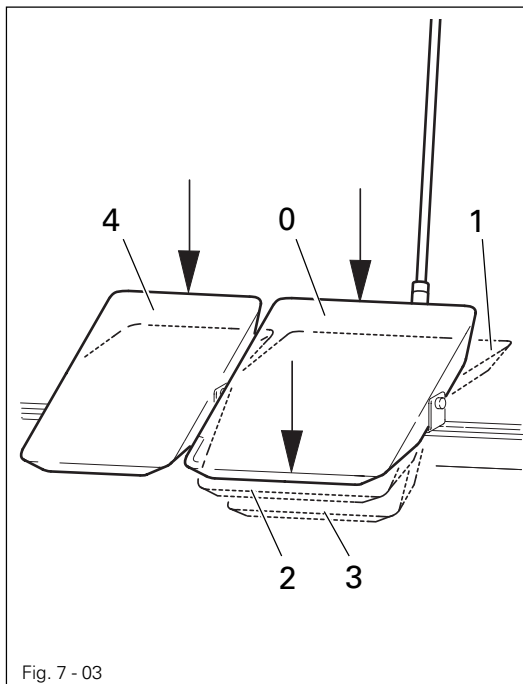

Fig. 7 - 02

- Different functions are triggered by pressing the different keys.
- Key 1: program interruption (see chapter 10.04 Program interruption) or reverse sewing (depending on setting).
- Key 2: - selecting function
- decreasing input values
- Key 3: - selecting function
- increasing input values

7.03 Pedal



- 0 = Machine stop
- 1 = Sew
- 2 = Raise roller presser
- 3 = Trim thread and raise roller presser
- 1 + 4 = Apply fullness



Other functions are described in **chapter 11 Programing**

7.04 Knee switch

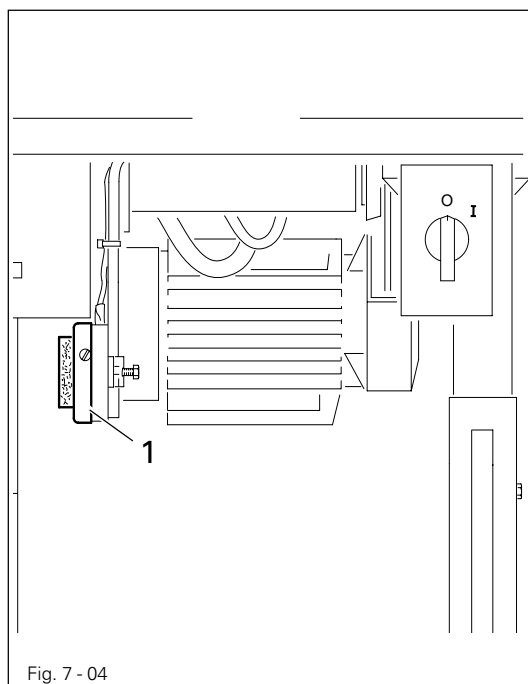

- By activating the knee switch **1** the end of the seam section can be signalized during **programed SEWING**.



The function of the knee switch **1** must be switched on using the control panel (see **chapter 11 Programing**).

7.05 Lever for lifting the roller presser

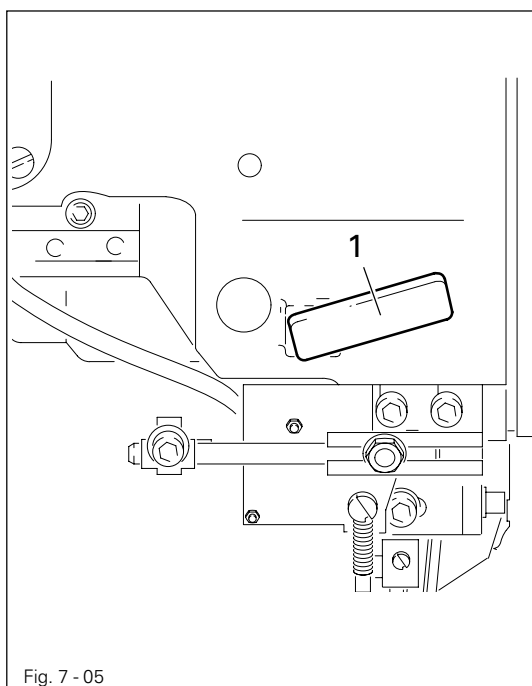

- The roller presser is raised by turning lever 1.

7.06 Control panel

The control panel consists of the display and two key panels.

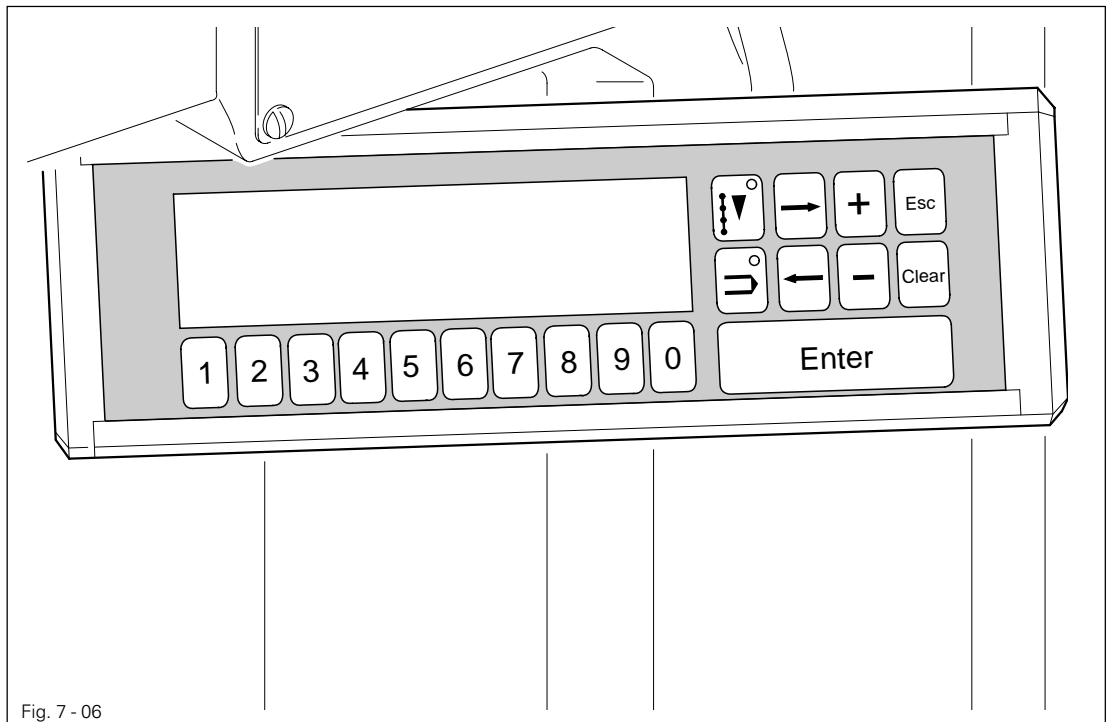

7.06.01 Display

In the basic screen the messages in the display are divided into three sections:

Status bar

The status bar is in the upper section of the display. Here, up to 5 pictograms with the corresponding values can be displayed (e.g. program number, number of seam section, stitch length etc.).

Text field

The text field is in the middle section of the screen, in which messages are displayed in 2 lines. Stylized seam sections can also be shown here with information about start and end bartacks, sewing direction and seam section end.

Pictogram bar

The pictogram bar can be found at the bottom of the display. Here, symbols are displayed whose corresponding functions can be called up via the **number keys**. Active functions are shown by a symbol displayed on a dark background.



Normal symbol (function not active)



Symbol on dark background (function active)

7.06.02 Operation-mode keys

There are two operation modes. The selected mode can be seen by the light emitting diode in the respective key.



SEWING mode



INPUT mode

7.06.03 Function keys

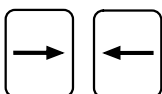

Arrow keys (right/left)

- Change menu pages
- for positioning the cursor when entering several values in one line

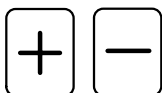

Plus/Minus keys

- selecting function
- for increasing and decreasing input values



Esc key

- for interrupting functions without taking on the value inputted
- for returning to superordinate menu functions
- for error acknowledgement after an error message



Clear key

- for returning the input value to 0
- for error acknowledgement after an error message



Enter key

- for confirming an input value
- for error acknowledgement after an error message

7.06.04 Number keys

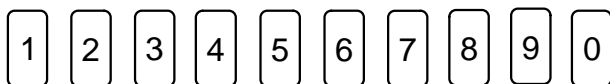

Below the display there is a row of number keys (1-0).

Depending on the current operating mode, these keys have the following functions:

- carrying out the function shown by the symbol displayed above the number key
- inputting a numerical value
- selecting functions or the next level of the menu



Double click = pressing a key twice in rapid succession

Mounting and commissioning the machine

8 Mounting and commissioning the machine



The machine must only be mounted and commissioned by qualified personnel!
All relevant safety regulations are to be observed!



If the machine is delivered without a table, it must be ensured that the frame and the table top which you intend to use can hold the weight of the machine and the motor. It must be ensured that the supporting structure is sufficiently sturdy, including during all sewing operations.

8.01 Mounting

The necessary electricity supply must be available at the machine's location.
There must be a stable and horizontal surface and adequate lighting at the machine's location.



The method of packaging used requires that the table top be lowered for transport. The following is a description of how to adjust the height of the table top.

8.01.01 Adjusting the table-top height

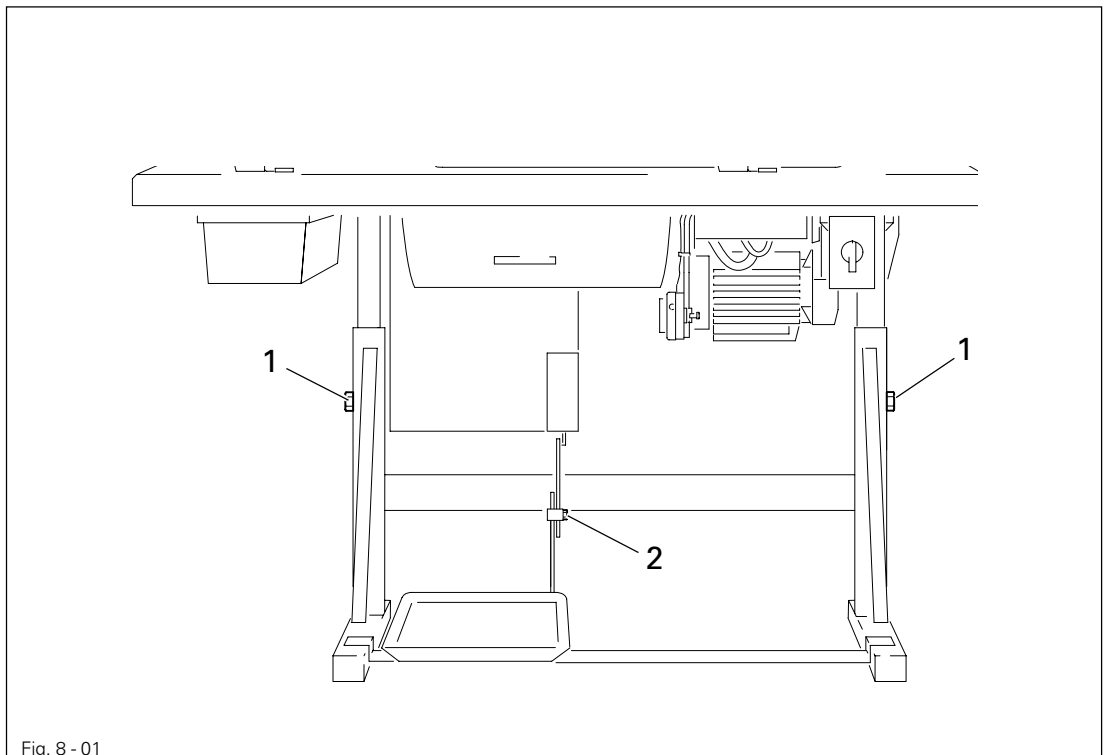
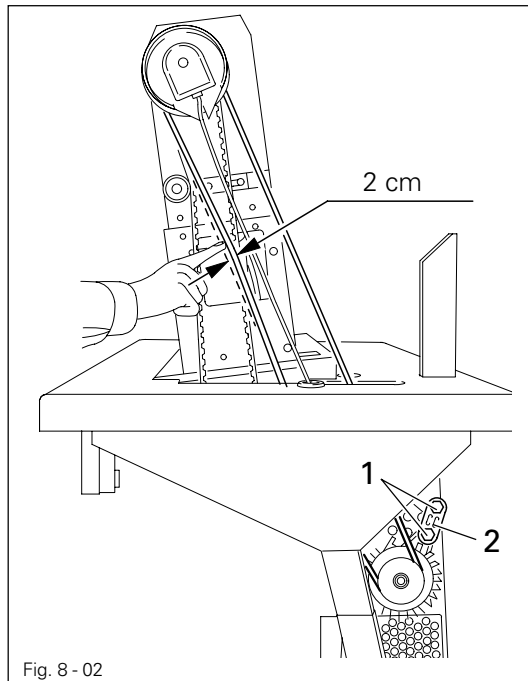

Fig. 8 - 01

- Loosen screws 1 and 2 and set the desired table-top height
- Tighten screws 1 well.
- Adjust the position of the pedal so that you can operate it comfortably and tighten screw 2.

8.01.02 Adjusting the V-belt tension



- Loosen nuts 1.
- Tighten the V-belt with belt take-up hanger 2.
- Tighten nuts 1.

8.01.03 Mounting the upper V-belt guard

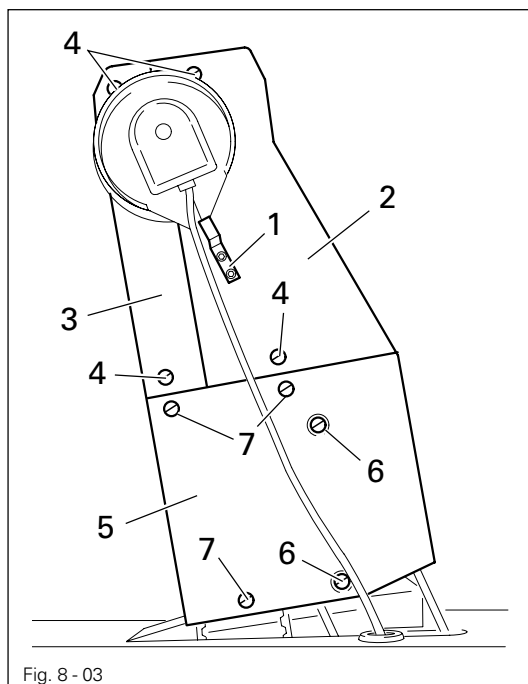

- Screw position stop 1 onto the right half of V-belt guard 2.
- Attach both halves 2 and 3 of the belt-guard with screws 4.
- Slide the lower section 5 of the V-belt guard with its slots behind the heads of retaining screws 6. Screw on with screws 7. Finally, tighten screws 6 through the holes.

Mounting and commissioning the machine

8.01.04 Mounting the lower V-belt guard

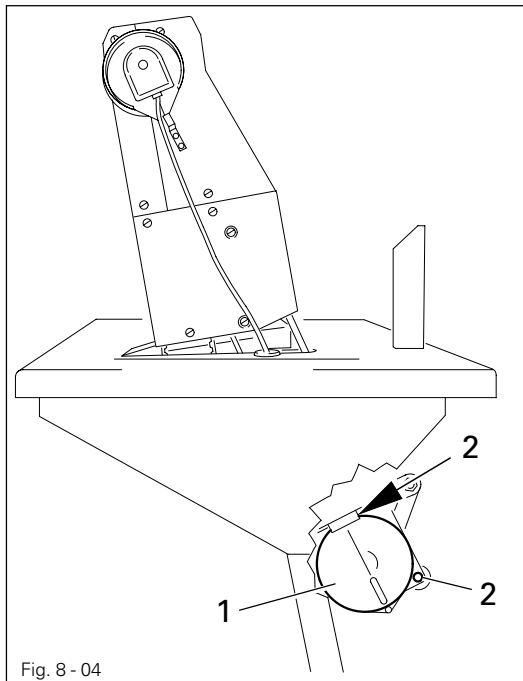

- Align belt-guard 1 in such a way that both the motor pulley and the V-belt run freely.
- Tighten screws 2.

8.01.05 Mounting the synchronizer

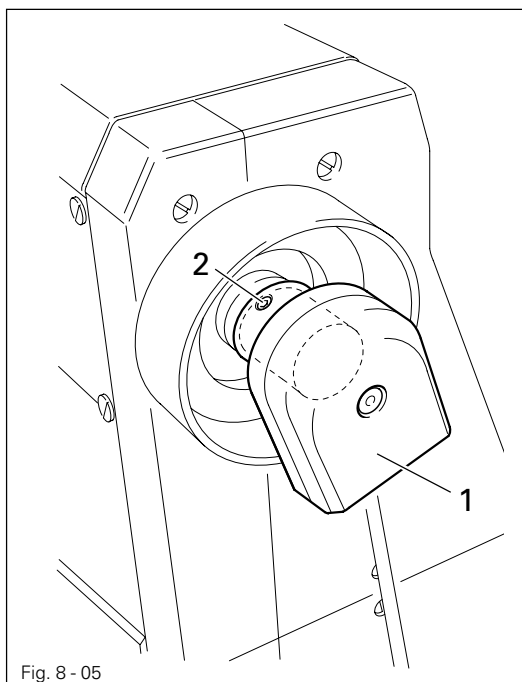

- Slide synchronizer 1 onto the shaft.
- Tighten screws 2 slightly.
- Plug the synchronizer plug into the electrical socket of the control box.
- Adjust the synchronizer (see **chapter 13.04.01 Adjusting the synchronizer**).

8.01.06 Mounting the spool holder

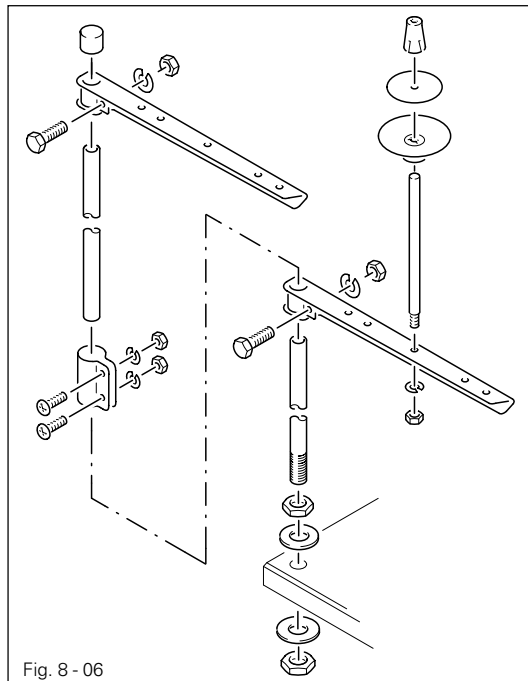

- Mount the spool holder as shown in Fig. 8 - 06.
- Insert the spool holder into the hole in the table top and affix it with the nuts enclosed.

8.02 Commissioning the machine

- Before commissioning the machine, check the electrical leads for any damage.
- Clean the machine thoroughly and oil it / fill with oil (see **chapter 12 Care and maintenance**).
- Have specialists ensure that the machine's motor can be operated with the available electricity supply and that it is connected correctly to the terminal box. If not, the machine must not be operated under any circumstances.

8.03 Turning the machine on/off

- Turn the machine on (see **chapter 7.01 On/Off switch**).

9

Preparation



All regulations and instructions in this Instruction Manual are to be observed!
Special attention is to be paid to the safety regulations!



All preparation work is only to be carried out by appropriately trained personnel.
Before all preparation work, the machine is to be separated from the electricity supply by removing the plug from the mains or switching off the On/Off switch!

9.01

Inserting the needle

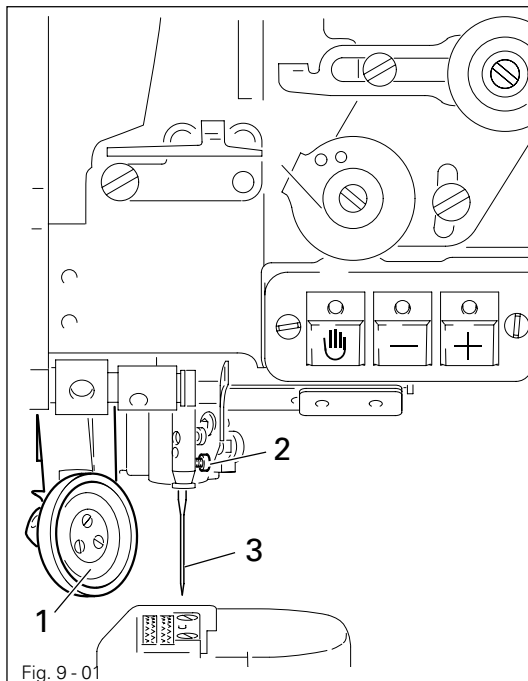

Turn the machine off!

Use only system 134-35R needles.

- Raise roller presser or band feed **1**.
- Pull roller presser or band feed **1** down slightly and swing it to the left.
- Loosen screw **2** and insert needle **3** until you feel it stop. The long groove must be facing the left.
- Tighten screw **2** and swing the roller presser back.



The selection of the correct needle depends on the model of the machine, as well as the material and threads being sewn (see chapter 3.02 Model, needle and thread).

9.02

Winding the bobbin thread, adjusting the thread tension

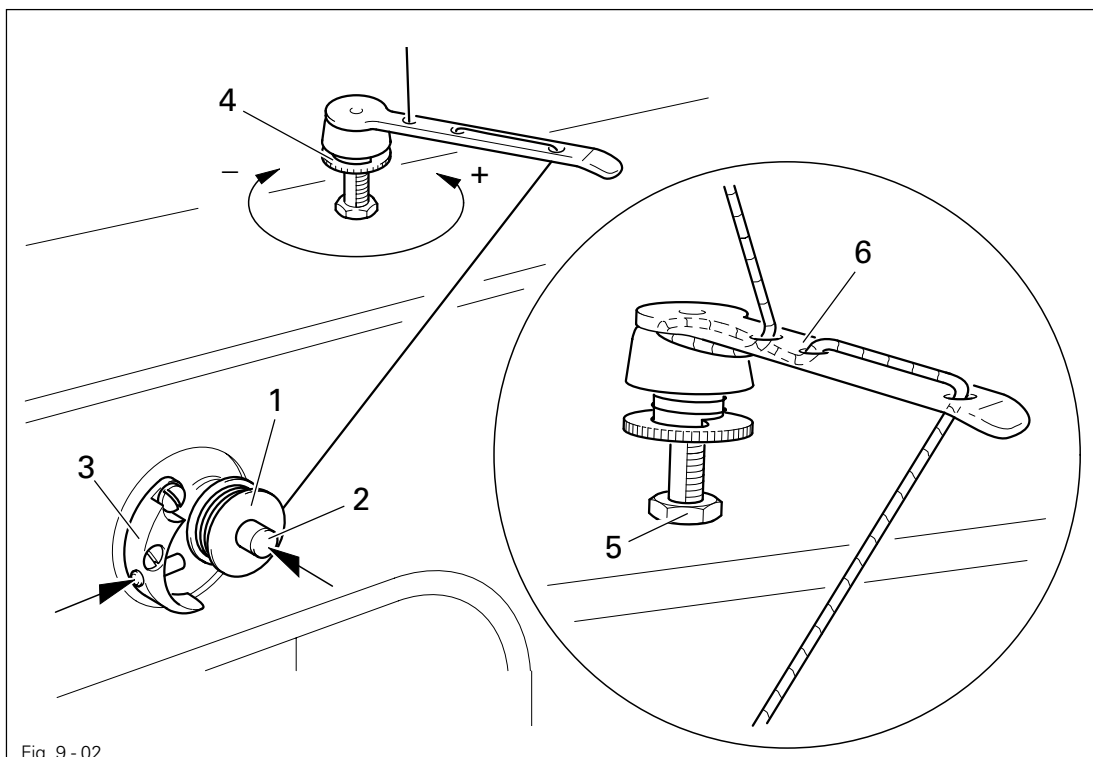

Fig. 9 - 02

- Place an empty bobbin 1 onto bobbin winder spindle 2.
- Thread the bobbin in accordance with Fig. 9 - 02 and wind it clockwise around bobbin 1 a few times.
- Switch on the bobbin winder by pressing the bobbin winder spindle 2 and lever 3 at the same time.



The bobbin fills up while you are sewing.

- The tension of the thread on bobbin 1 can be adjusted with knurled screw 4.
- The bobbin winder stops automatically when bobbin 1 is full.

If the thread is wound unevenly:

- Loosen nut 5.
- Turn thread guide 6 accordingly.
- Tighten nut 5.

9.03 Removing/Inserting the bobbin case

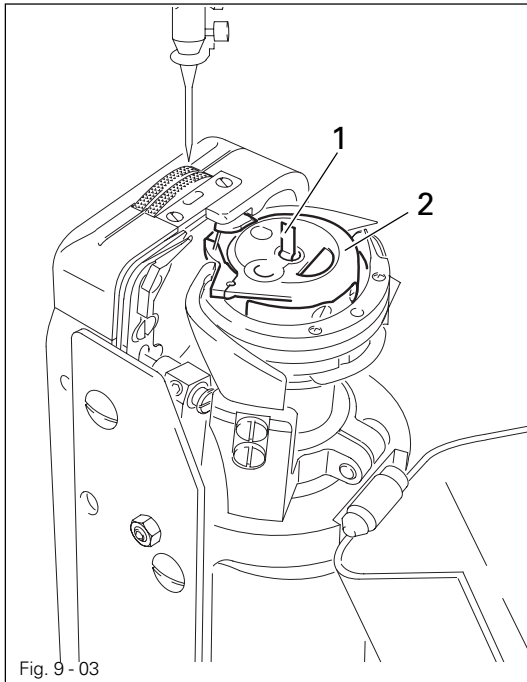

Turn the machine off!

Removing the bobbin case:

- Open the post cap.
- Raise latch 1 and remove bobbin case 2.

Inserting the bobbin case:

- Insert bobbin case 2.
- Close the latch and close the post cap.

9.04 Threading the bobbin case / Adjusting the bobbin thread tension

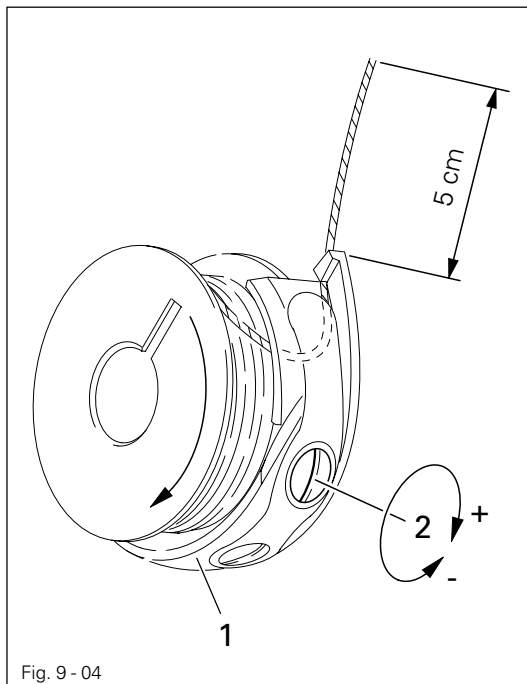

- Insert the bobbin into the bobbin case 1.
- Pass the thread through the slot under the spring.
- Pass the thread through the notch.
- Adjust the thread tension by turning screw 2.



When the thread is pulled, the bobbin must rotate in the direction of the arrow.

9.05

Threading the needle thread / Adjusting the needle thread tension

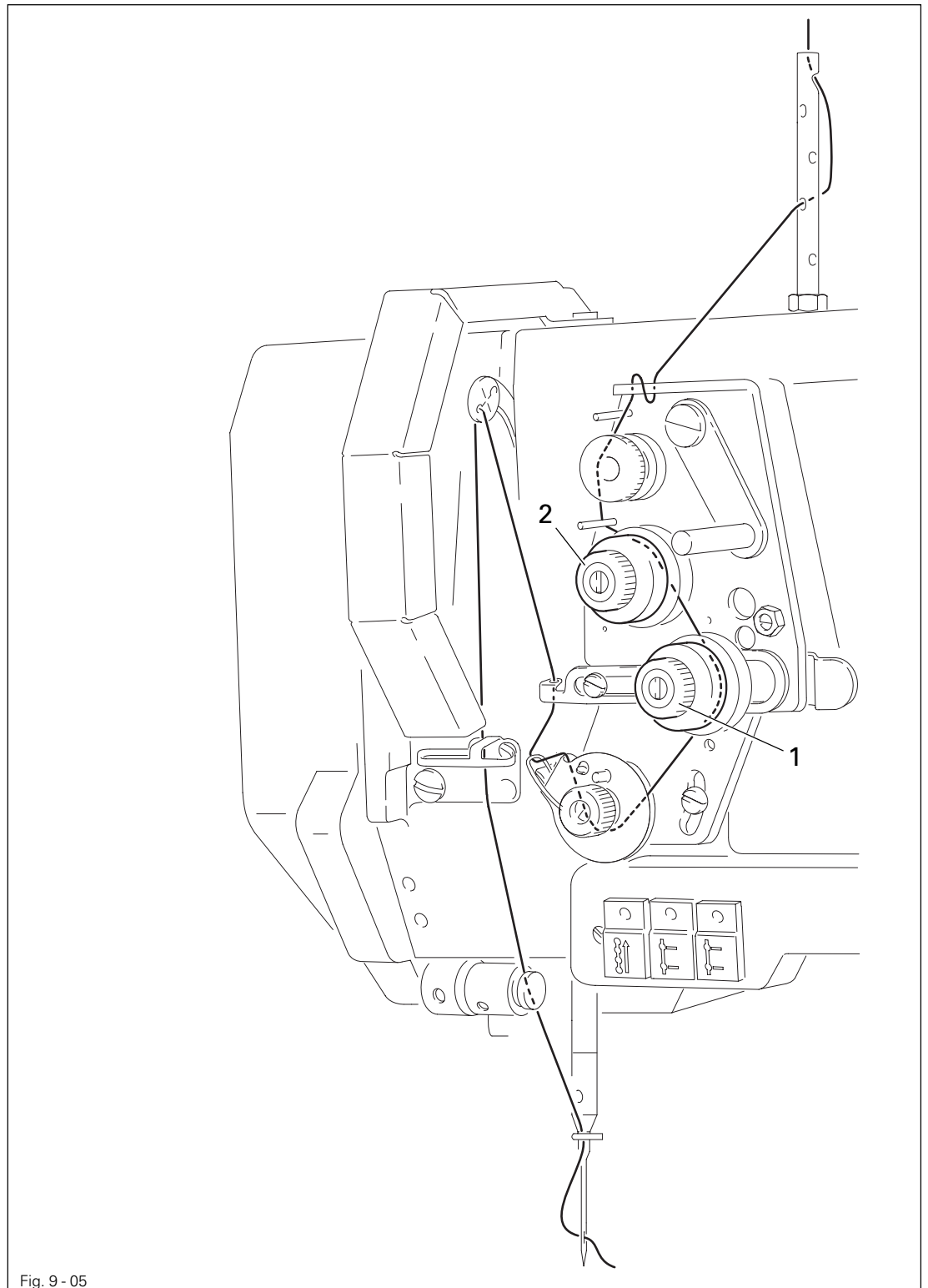

Turn the machine off!

- Thread the machine as shown in Fig. 9-05.
- Adjust the needle thread tension by turning knurled screws 1 and 2.

9.06 Adjusting the stitch length

- Turn the machine on.



- Select the function **SEWING**.

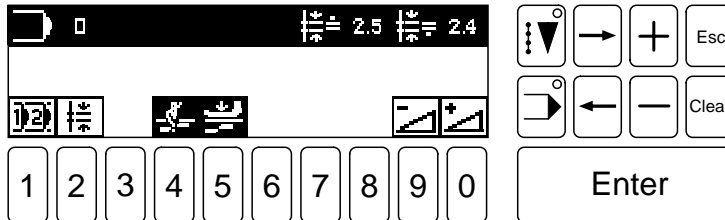

Fig. 9 - 06

If the display shown in Fig. 9-06 does not appear:



- Select the function **select program**.



- Enter program number **0**.

Enter

- Confirm with the **Enter** key.



- Select the function **stitch length** with **number key 2**.

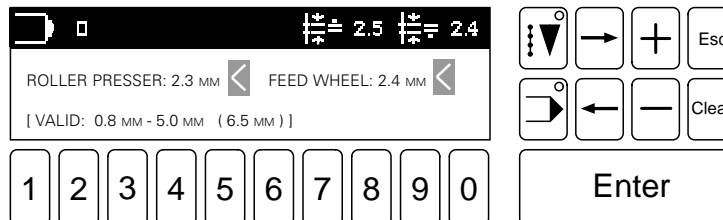

Fig. 9 - 07

- Using the **number keys**, input the desired stitch lengths.



The value inputted will also be assumed by the feed wheel and the roller presser.

If the values for the feed wheel and the roller presser are to vary, the feed wheel and the roller presser must be selected individually.

When inputting varying feed lengths:

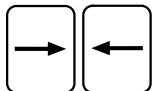

- Select the feed wheel or roller presser separately using the **arrow keys** (observe cursor).

Enter

- Input the required value and confirm with the **Enter** key.

9.07 Selecting a language

- Turn the machine on.



- Select INPUT mode

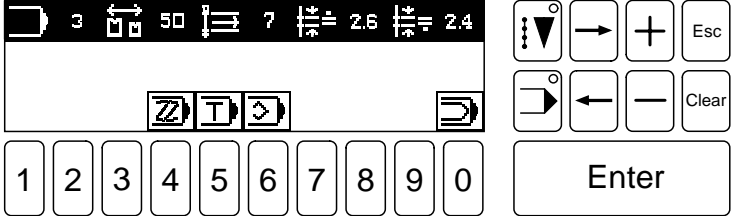

Fig. 9 - 08



- Select the function input menu with number key 0.



- Select the function SWITCH FUNCTIONS with number key 1.



- Select the function LANGUAGES with number key 3.

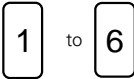

- Select the desired language with the number keys:

- 1 = (D)
- 2 = (GB)
- 3 = (F)
- 4 = (I)
- 5 = (E)
- 6 = (P)

- The language is taken on immediately once the corresponding number has been entered.

10 Sewing

10.01 Manual sewing

- Turn the machine on.



- Select **SEWING** mode.



- Select the function **select program**.



- Enter program number **0**.

Enter

- Confirm the input with the **Enter** key.

- After these inputs you can begin sewing.

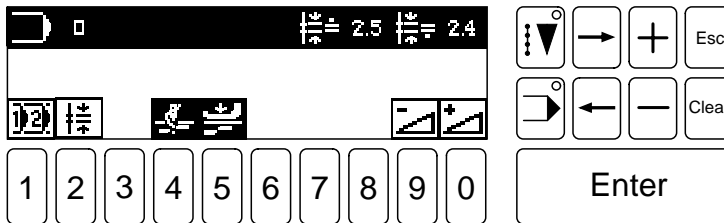

Fig. 10 - 01

Explanation of the symbols in the display:



Program selection

This function opens a direct menu for selecting the desired seam program.



Stitch length

This function opens a direct menu for inputting the desired value for the feed motion of the feed wheel and the roller presser.



Thread trimming

When this function is active, the thread is cut when the pedal is pressed backwards (see [chapter 7.03 Pedal](#)).



Roller presser down after trimming

When this function is active, the roller presser is lowered after the trimming process.



Correction value minus

When this function is active, the value for the fullness correction can be decreased.



Correction value plus

When this function is active, the value for the fullness correction can be increased.

10.02 Manual application of fullness

- Turn the machine on.



- Select **SEWING** mode.



- Select the function **select program**.



- Enter program number **0**.

Enter

- Confirm the input with the **Enter** key.

- After these inputs you can begin sewing.

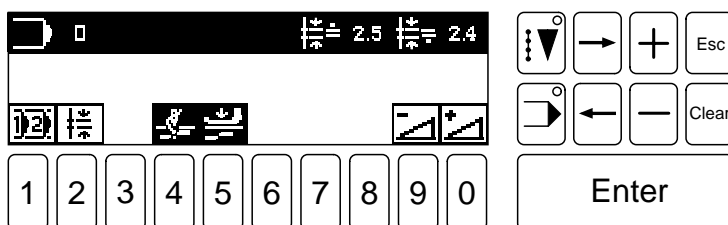

Fig. 10 - 02

- By operating the 2nd pedal, fullness can be applied to the top material ply.
- When the 2nd pedal is pressed, a bar diagram is indicated in the display.

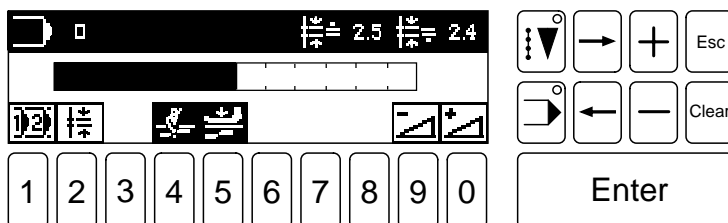

Fig. 10 - 03

- The fullness amount actually applied is indicated symbolically by the black bar in the display.
- The maximum amount of fullness is set at 4.0 mm and can be changed in input menu: "MAX. STITCH LENGTH, 2nd PEDAL" (see chapter 10.03).

10.03 Changing the maximum fullness amount.



- Select INPUT mode

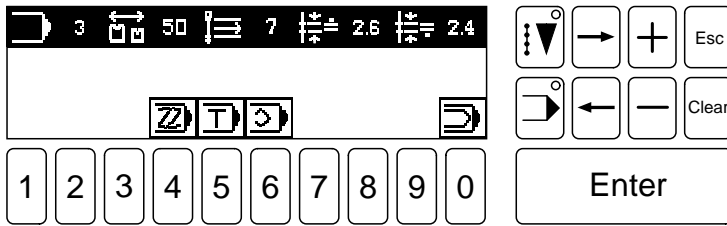

Fig. 10 - 04



- Select the input menu function (the first menu level appears in the display).

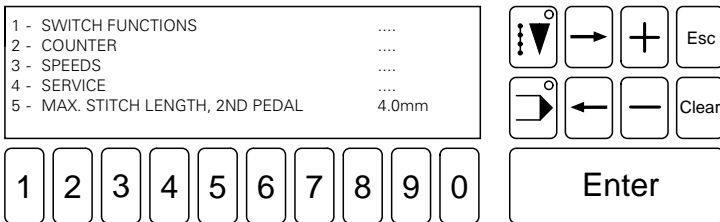

Fig. Fig. 10 - 05

5

- Select the function MAX. STITCHLENGHT 2ND PEDAL with number key 5.

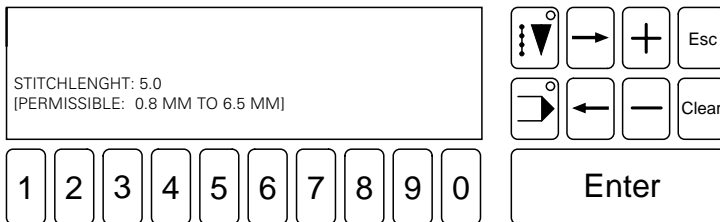

Fig. Fig. 10 - 06

10.04 Sewing with the fixed programs

Fixed programs are stored at program numbers **1** and **2**.

The fixed programs are used for the fast and comfortable sewing of seams with varying stitch lengths and/or levels of fullness.

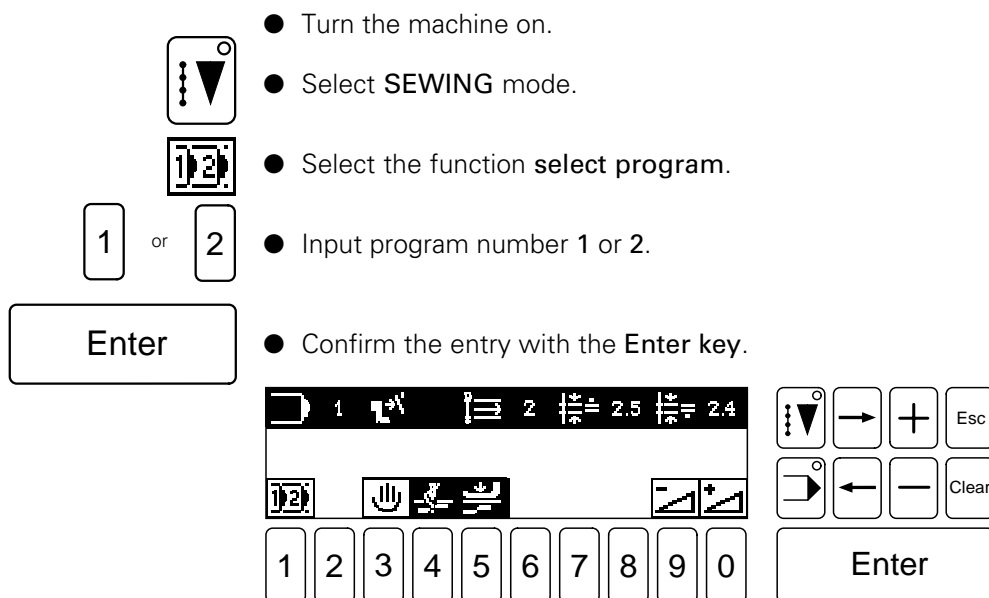

Fig. 10 - 07

Explanation of the symbols in the display:



Program selection

This function opens a direct menu for selecting the desired sewing program.



Program interruption

This function interrupts the sewing of the seam program (see **chapter 10.04 Program interruption**).



Thread trimming

When this function is active, the thread is cut when the pedal is pressed backwards (see **chapter 7.03 Pedal**)



Roller presser down after trimming

When this function is active, the roller presser is lowered after the trimming process.



Correction value minus

When this function is active, the value for the fullness correction can be decreased.



Correction value plus

When this function is active, the value for the fullness correction can be increased.



For information on altering fixed programs see **chapter 11.10.01 Altering fixed programs**.

10.05 Programed sewing

Pre-programed seams can be selected with the program numbers 3-49.

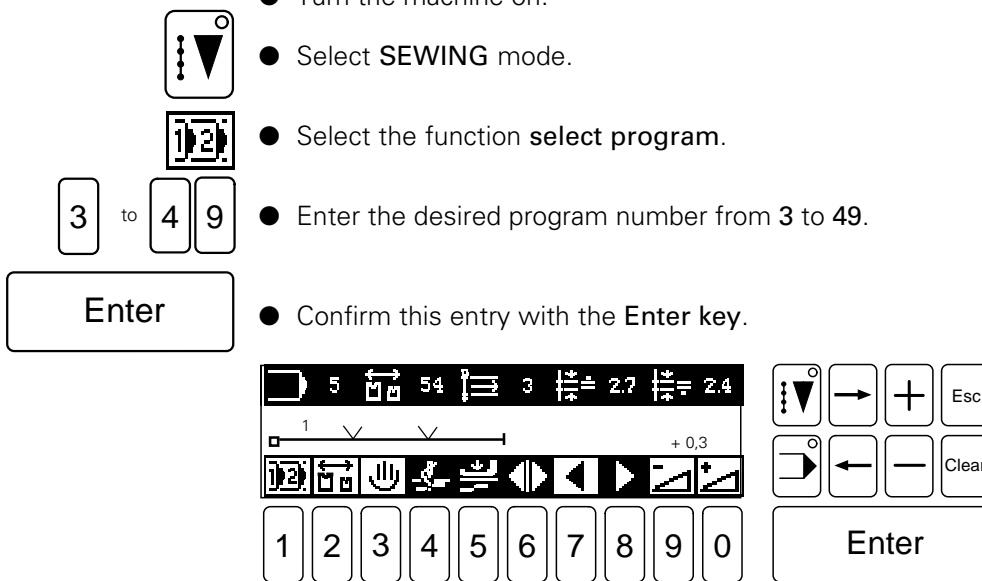

Fig. 10 - 08



In the text line you will see a stylized seam section with a classification of the current seam section. Furthermore, the value for the fullness change in the seam is displayed.

Explanation of the symbols:



Program selection

This function opens a direct menu for selecting the desired sewing program.



Size selection

Opens a direct menu for the selection of the desired size (see [chapter 11.11 Selecting the size](#)).



Program interruption

This function interrupts the sewing of the seam program (see [chapter 10.04 Program interruption](#)).



Thread trimming

When this function is active, the thread is cut when the pedal is pressed backwards (see [chapter 7.03 Pedal](#)).



Roller presser down after trimming

When this function is active, the roller presser is lowered after the trimming process.



Automatic seam change

When this function is activated, at the end of the seam the machine switches to the right or left seam, respectively.



Left seam

When this function is active, a left seam is sewn.



Right seam

When this function is active, a right seam is sewn.



Correction value minus

When this function is activated, the value for the fullness correction can be decreased.



Correction value plus

When this function is activated, the value for the fullness correction can be increased.

10.06 Program interruption



If the sewing of a program is to be interrupted (e.g. in the case of a thread breakage), the function **program interruption** must be activated.

- When pressed once, the machine switches to **manual SEWING**.
- If you continue sewing manually the stitch length values will be taken from the seam program (symbol in display appears on a dark background).

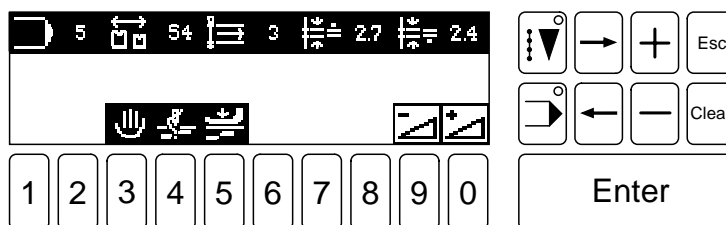
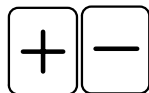

Fig. 10 - 09



- By using the **plus/minus keys** you can select the seam section in which the seam program is to be continued.
- When the key is pressed a second time, you enter the selected seam section. **Programed SEWING** is continued.

10.07 Error messages

In the case of an error message, the text and pictogram bars in the display are written over. An error message is triggered by false settings, false elements or seam programs or by overload.

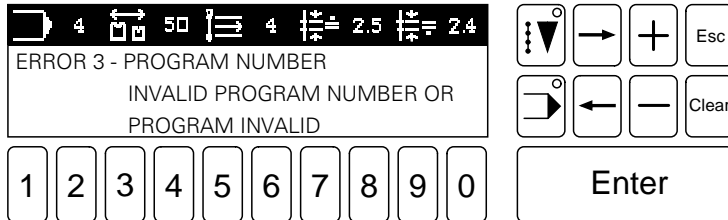

Fig. 10 - 10

- The error must be corrected before the machine can be operated.

To correct errors:

- By pressing the **Enter** key you skip back to the incorrect entry.
- Make the correct entry.



Information on correcting errors can be found in the corresponding service handbook. Errors may only be corrected by authorized specialists.

11 Programming

11.01 Symbols in the status bar

Information on the current seam section are displayed in the upper area of the display. Symbols with the corresponding values will also be displayed.

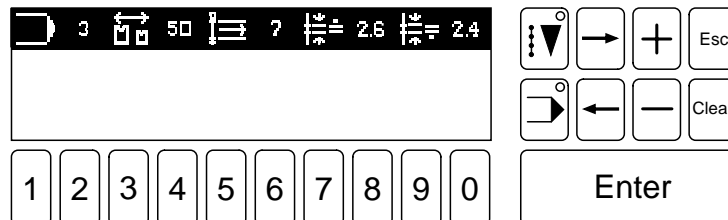

Fig. 11 - 01



Program number

The number of the selected seam program appears behind this symbol.



Current size

The current size is displayed behind this symbol.



Knee switch

The symbol indicates that the KNEE SWITCH function in the input menu is activated.



If the KNEE SWITCH function is activated, the symbol for knee switch appears in place of the current size symbol. (See **chapter 11.07 Summary of the functions in the input menu**).

When the function is active, the end of the seam section is signaled using the knee switch.

The **seam length** and **size selection** functions cannot be selected when the knee switch is activated.



Number of seam sections

The total number of seam sections contained in the current seam program is displayed behind this symbol.



Roller presser feed motion

The value of the stitch length in the current seam section for the top feed is displayed behind this symbol.



Stitch length (feed wheel)

The value of the stitch length in the current seam section for the bottom feed dog is displayed behind this symbol.

11.02 Symbols in the text and graphic fields

Corresponding to the operation mode, a stylized seam program or seam section is shown in the middle of the display.

11.02.01 Text and graphic fields in the SEWING mode

During **programed sewing**, a stylized seam program is displayed.

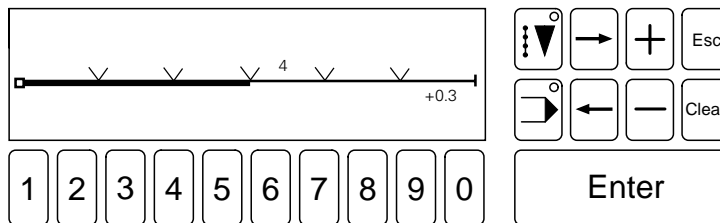

Fig. 11 - 02

In the example illustrated above, a seam program with 6 seam sections is displayed. For the entire seam, a fullness correction value of +0.3mm is used. The first three seam sections have already been sewn. The fourth seam section is currently being sewn (current seam section).

— Seam

∨ Notch

▣— Beginning of seam

∨—∨ Seam section already sewn

∨⁴—∨ Current seam section (incl. seam section number)

—→ End of seam

+0.3 Fullness correction value

This value is added to the feed motion of the roller presser.



The illustration in the display is not true to scale.

11.02.02 Text and graphics fields in the INPUT mode

In the **INPUT** mode a stylized seam section is displayed.

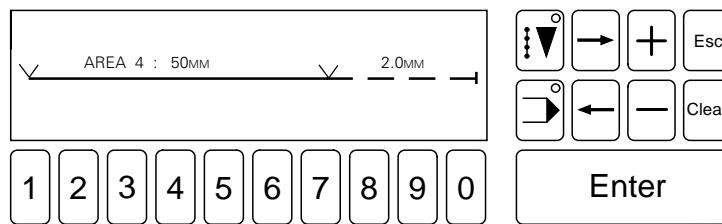

Fig. 11 - 03

In the above example, area 4 is shown as the current seam section. This seam section is 50 mm long and a graduation of 2 mm is being worked in.

—— Seam

∨ Notch

∨ AREA 4 : ∨ **Current seam section** (incl. seam section number and seam length)

∨ 2.0MM ∨ **Graduation section** (incl. graduation)



The illustration in the display is not true to scale.

11.03 Symbols in the pictogram bar

In this control concept, the functions are selected exclusively using the **number keys**. The available functions are displayed as symbols in the pictogram bar of the display. You select the function by pressing the **number key** which is below it.

Initial state **INPUT** mode:

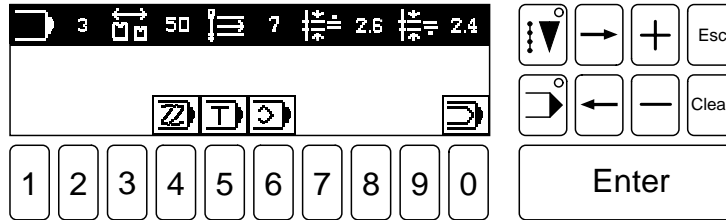

Fig. 11 - 04

Explanation of the symbols in the display:



Programming

Opens a direct menu for programming seams. The program is entered via the control panel.



Teach In

Opens a direct menu for programming seams. Here, the system "learns" the desired seam.



Program administration

Opens a menu with further functions for the administration of program data.



Input menu

This function opens a menu with special functions, selection of language, switch functions, parameter settings and service functions.

11.04 Summary of the functions in SEWING mode



The functions which can be selected in SEWING mode after the machine is switched on depend on the program number displayed in the status bar:

Program number 0 : manual SEWING

Program numbers 1 - 49 : programmed SEWING

(Program numbers 1 and 2 have fixed programs assigned to them.)



- By choosing the **program selection** function, you can switch between **manual** and **programed SEWING**.



SEWING mode



Program selection

0

selection of manual SEWING



program selection



stitch length



thread trimming



roller presser down after trimming



correction value minus



correction value plus

1 to 4 9

selection of programed SEWING



program selection



size selection (not applicable for fixed programs 1 and 2)



program interruption (switching to manual SEWING)



thread trimming



roller presser down after trimming



correction value minus



correction value plus



thread trimming



roller presser down after trimming



automatic seam change (not applicable for fixed programs 1 and 2)



left seam (not applicable for fixed programs 1 and 2)



right seam (not applicable for fixed programs 1 and 2)



correction value minus



correction value plus

11.05 Summary of the functions in INPUT mode



INPUT mode



Programming



program number



size selection



stitch length (feed wheel)



automatic seam change



left seam



right seam



input comment



programming



seam section



seam length



graduation



roller presser feed motion



INS



DEL



left seam



right seam



end of seam



Teach In



program selection



size selection



stitch length (feed wheel)



automatic seam change



left seam



right seam



input comment



Teach In



graduation



roller presser feed motion



left seam



right seam

● after pedal activation



notch



left seam



right seam



Program administration

see chapter 11.06



Input menu

see chapter 11.07

11.06 Summary of the functions in program administration



Program administration

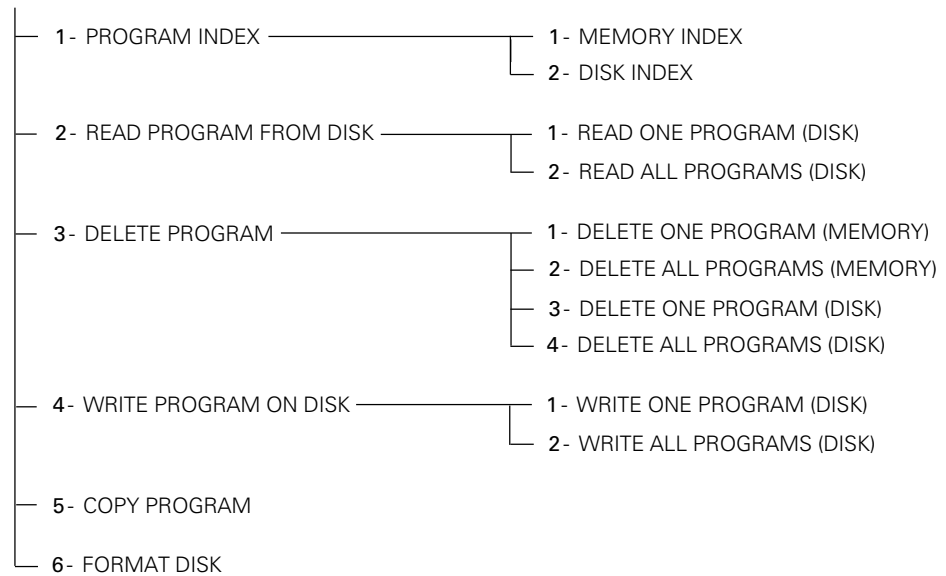

11.07 Summary of the functions in the input menu



Input menu

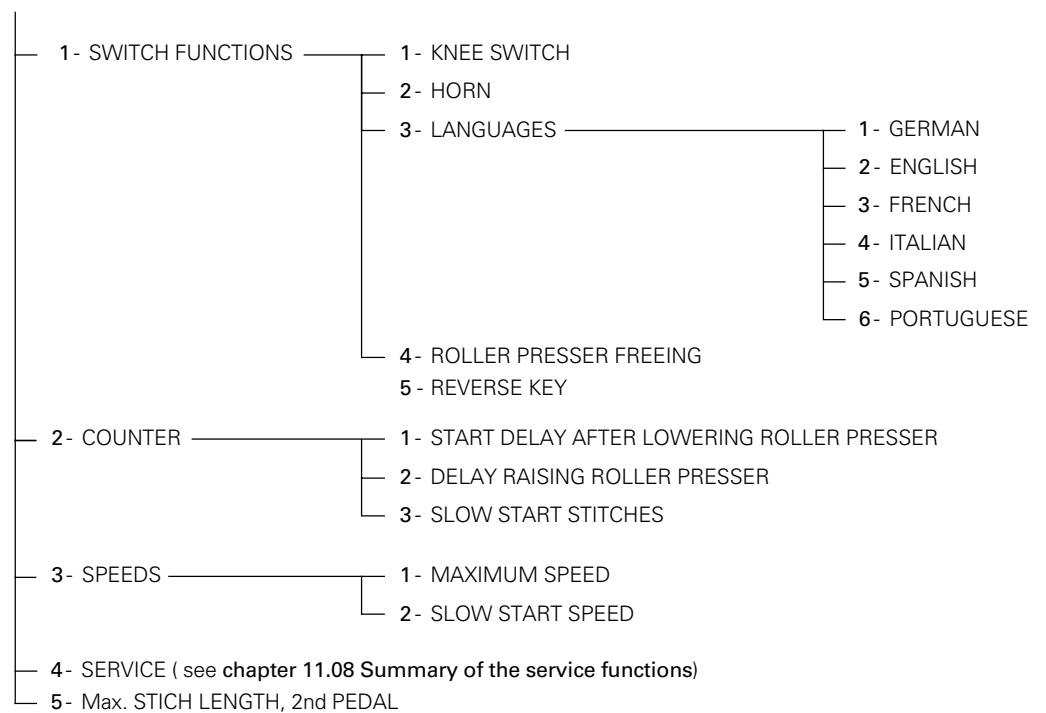

11.08 Summary of the service functions

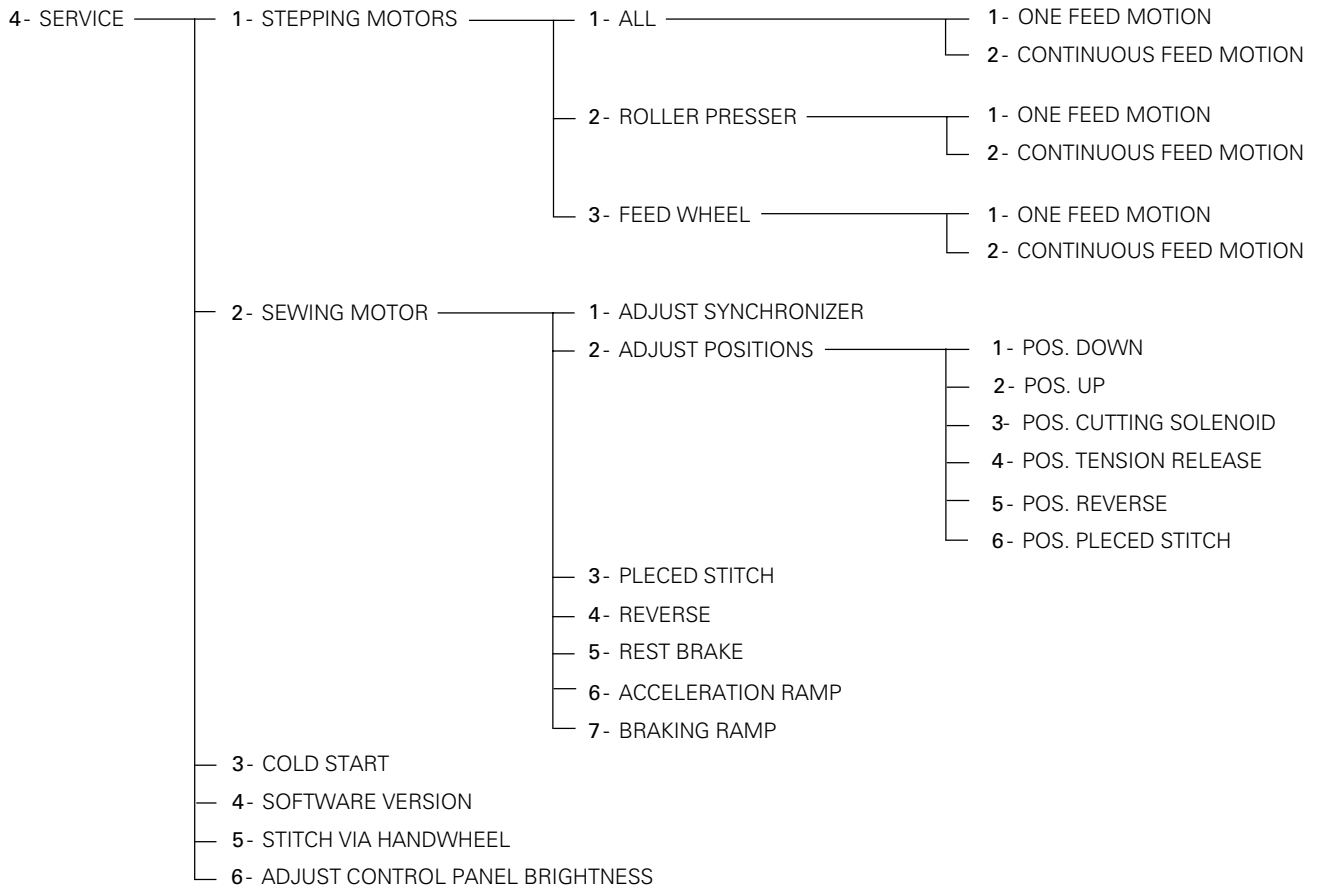

11.09 Selection of functions from menu levels



- Select INPUT mode

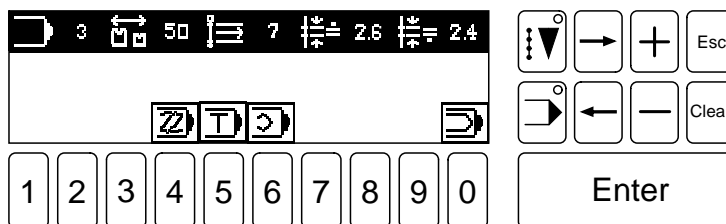

Fig. 11 - 05



- Select the input menu function (the first menu level appears in the display).

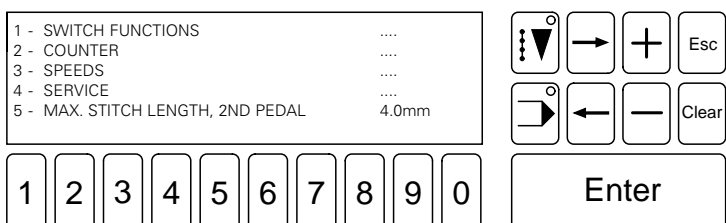

Fig. 11 - 06

- 4** ● Select the function SERVICE with **number key 4**.

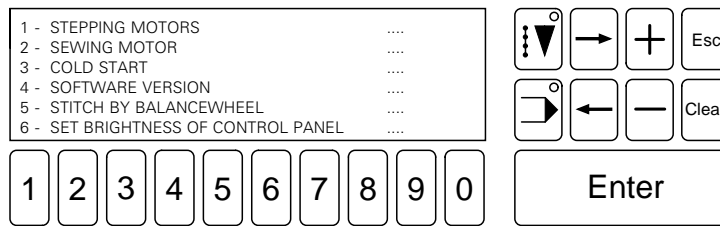

Fig. 11 - 07

- 2** ● Select the function SEWING MOTOR with **number key 2**.

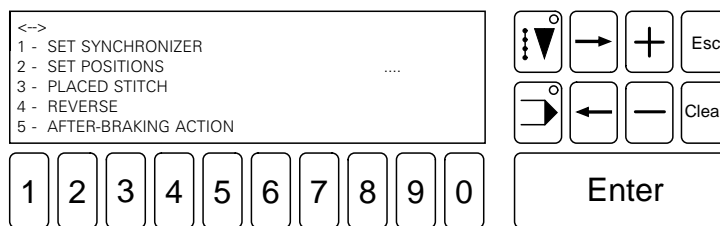

Fig. 11 - 08

- 1** ● Select the function ADJUST SYNCHRONIZER with **number key 1**.
 The display for adjusting the synchronizer appears:

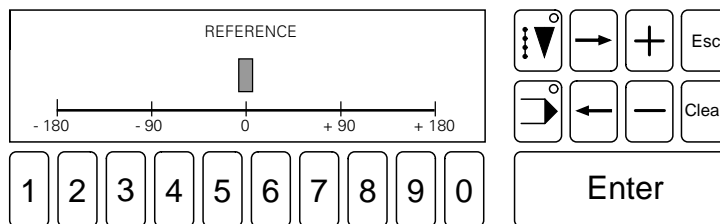

Fig. 11 - 09

Summary of the input steps:



INPUT mode



Function input menu

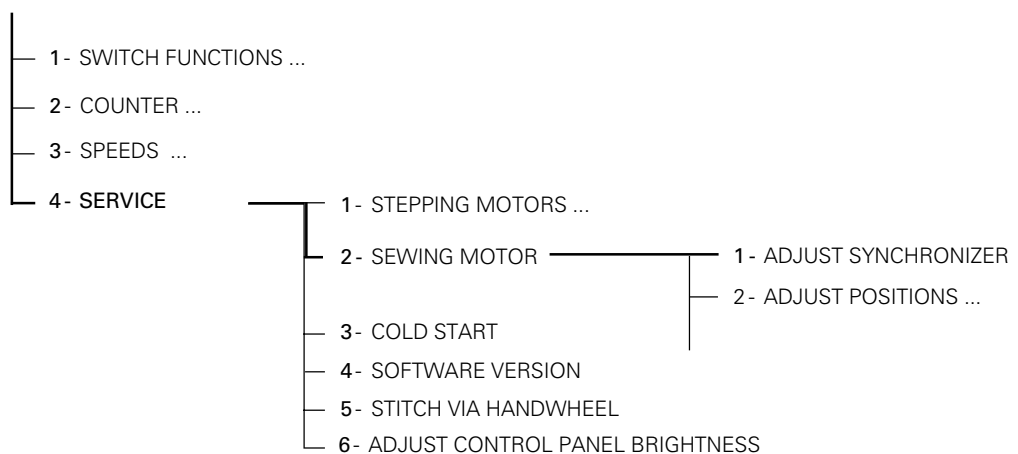

11.10 Creating seam programs

11.10.01 Altering fixed programs



- Select INPUT mode.

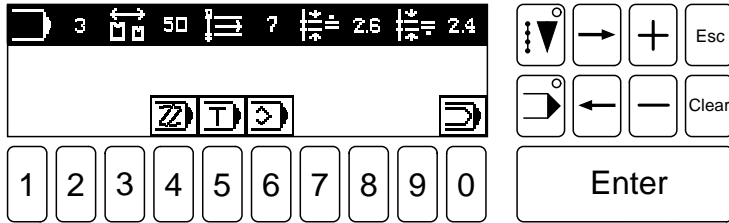

Fig. 11 - 10



- Select function Programming.

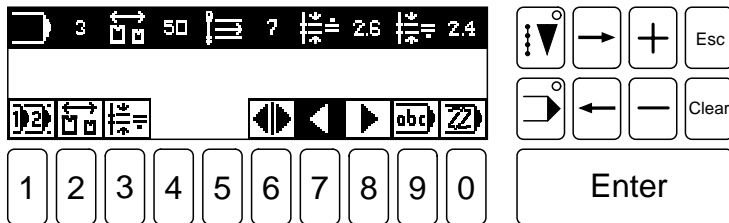

Fig. 11 - 11



- Select function Program selection.

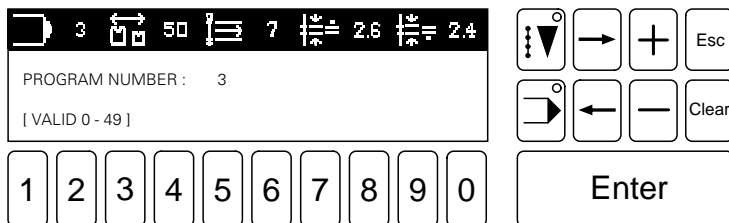

Fig. 11 - 12

Select fixed programs:

1

or

2

- Enter program number 1 or 2.

Enter

- Confirm the entry with the Enter key

The display for changing the basic data appears:

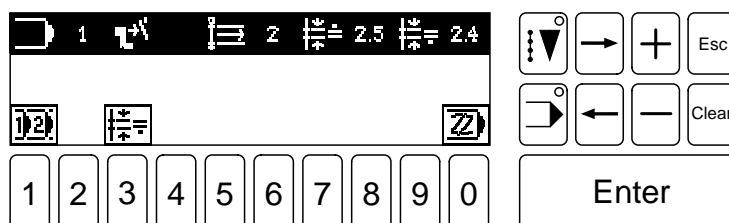

Fig. 11 - 13

Explanation of the symbols in the display:



Program selection

Opens a direct menu for selecting a desired seam program.



Stitch length (feed wheel)

This function opens a direct menu for inputting the desired values for the stitch lengths of the feed wheel in the entire seam program.

- The basic data of the sewing program can be changed using the above-named functions.



Programming

Opens a direct menu for inputting or changing seam sections of a fixed program.

Changing the individual seam sections of a fixed program:



- Select function **programming** again.

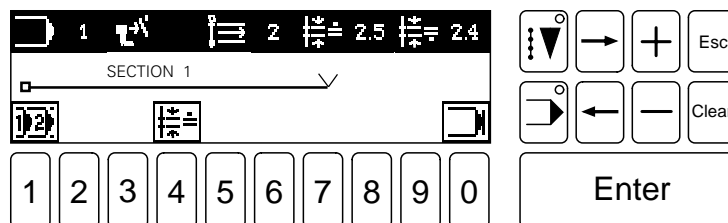

Fig. 11 - 14

Explanation of the symbols in the display:



Seam section selection

Opens a direct menu for selecting the desired seam section within the seam program.



Roller presser feed motion

Opens a direct menu for inputting the desired value for the feed motion of the roller presser in the current seam section.



Program end

The symbol indicates the end of the program (display function only).

11.10.02 Programming



- Select **INPUT** mode.

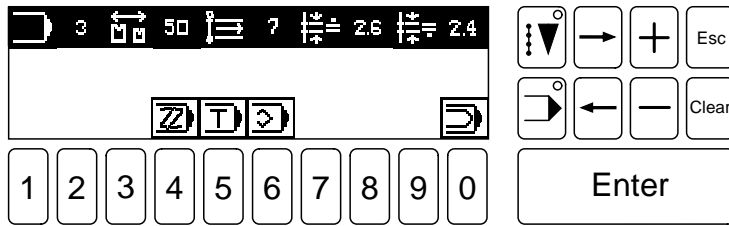

Fig. 11 - 15



- Select function **Programming**. The menu for inputting the basic data appears:

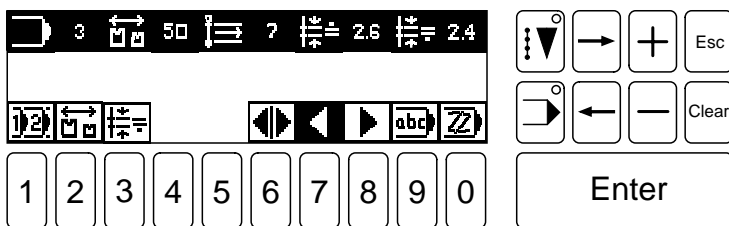

Fig. 11 - 16

Explanation of the symbols in the display:



Program selection

Opens a direct menu for selecting the desired seam program.



Size selection

Opens a direct menu for selecting the size (see **chapter 11.11 Selecting the size**).



Stitch length (feed wheel)

Opens a direct menu for inputting the desired value for the stitch length in the entire seam program.



Automatic seam change

When the function is active, the machine automatically switches to the left seam after having sewn the right seam, and vice versa.



Left seam

When the function is active, the left seam is sewn.



Right seam

When the function is active, the right seam is sewn.



Comment

Opens a menu for inputting a comment of up to 14 characters.

- Via the above-mentioned functions, the basic data of a seam program can be entered or changed.



Programming

Opens a direct menu for entering or changing seam sections of the seam program.

Inputting and/or changing the individual seam sections of a seam program:

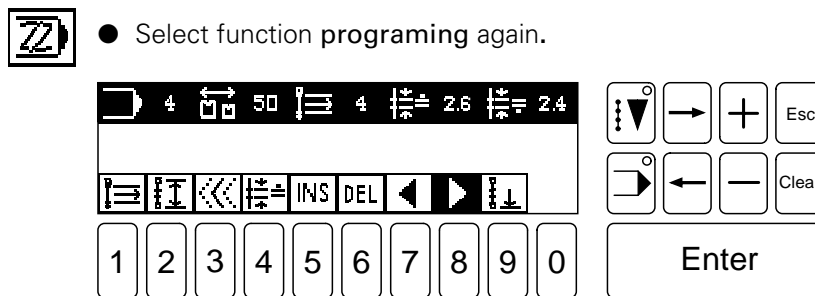











Fig. 11 - 17

Explanation of the symbols in the display:

- 
Seam section selection
 Opens a direct menu for selecting the desired seam section within the seam program.
- 
Seam length
 Opens a direct menu for inputting the desired value for the seam length in the current seam section. (The function KNEE SWITCH must not be activated.)
- 
Graduation
 Opens a direct menu for inputting the desired graduation in the current seam section.
- 
Roller presser feed motion
 Opens a direct menu for inputting the desired value for the feed motion of the roller presser in the current seam section.
- 
Insert
 Inserts a seam section into the current seam program. The current seam section is moved behind by one place.
- 
Delete
 Deletes the current seam section.
- 
Left seam
 When the function is active, the left seam is sewn.
- 
Right seam
 When the function is active, the right seam is sewn.
- 
End of seam
 Completes the current seam and switches over to entering the data for the second seam.
- 
End of program
 Ends inputting of the seam program.



The **end of seam** function is only displayed if you have chosen the **automatic change of seam** function when entering the basic data and while you are entering the data for the first seam. Otherwise, the function **end of program** is displayed.

11.10.03 Teach In

When this function is activated, the machine is able to "learn" a program during sewing.



The function KNEE SWITCH in the input menu must not be active (see **chapter 11.01 Symbols in the status bar**).



- Select INPUT mode.

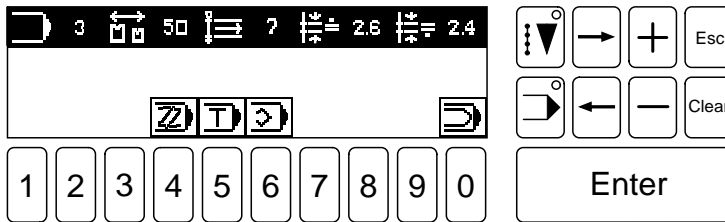

Fig. 11 - 18



- Choose the Teach In function. The display for entering the basic data appears:

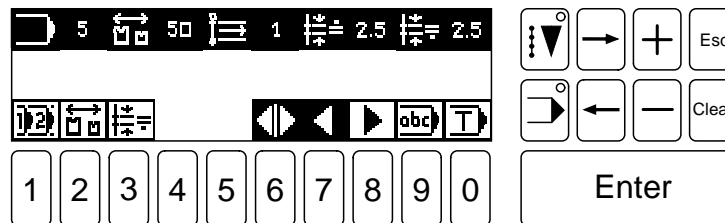

Fig. 11 - 19

Explanation of the symbols in the display:



Program selection

Opens a direct menu for selecting the desired seam program.



Basic size

Opens a direct menu for selecting the basic size of the garment. (See **chapter 11.11 Selecting the size**).



Stitch length (feed wheel)

Opens a direct menu for entering the desired value for the stitch length in the entire seam program.



Automatic seam change

When this function is activated, the machine automatically switches to the left seam after having programmed the right seam, and vice versa.



Left seam

When this function is activated, the left seam is sewn.



Right seam

When this function is activated, the right seam is sewn.



Comment

Opens a menu for inputting a comment of up to 14 characters.

- Via the above-mentioned functions, the basic data of a seam program can be entered or changed.



Teach In

Opens a direct menu for entering or changing seam sections in the seam program.

How to enter individual seam sections of the seam program:



- Select **Teach In** once again.

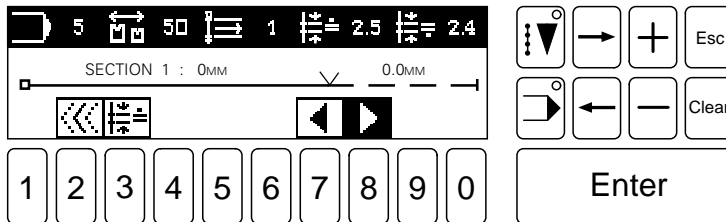

Fig. 11 - 20



Graduation

Opens a direct menu for inputting the desired graduation in the current seam section.



Roller presser feed motion

Opens a direct menu for inputting the desired value for the feed motion of the roller presser in the current seam section.



Left seam/right seam

The activated function marks the seam currently being sewn.

- Step on pedal.
The seam is sewn with the selected feed motion of the roller presser.
- After the machine comes to a standstill for the first time, the following display appears:

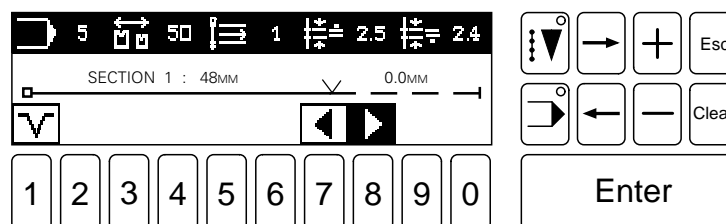

Fig. 12 - 21



Notch

Stores the seam section already sewn and switches to input of the next seam section.



Left seam/right seam

The activated function marks the seam currently being sewn.

- By trimming the thread (pedal position 3 - see **chapter 7.03 Pedal**), you end the entire seam program, and it is stored.

11.11 Selecting the size



The function KNEE SWITCH in the input menu must not be activated (see chapter 11.01 Symbols in the status bar).



Depending on the operation mode, the basic size or the size, respectively, may be selected using the **size selection** function. The following sizes are available:

- Men's sizes (German)

Basic size: **50**

Sizes: 44, 46, 48, **50**, 52, 54, 56, 58, 60, 62, 64, 66, 68, 70, 72, 74, 88, 90, 94, 98, **102**, 106, 110, 114, 118, 122, 126, 130, 134, 138, 142, 146, 22, 23, 24, **25**, 26, 27, 28, 29, 30, 31, 32, 33, 34, 35, 36, 37

- Men's sizes (American)

Basic size: **40**

Sizes: 34, 35, 36, 37, 38, 39, **40**, 41, 42, 43, 44, 45, 46, 47, 48, 49, 50, 51, 52, 53, 54, 55, 56, 57, 58, 59, 60

- Ladies' sizes (German)

Basic size: **38**

Sizes: 34, 36, **38**, 40, 42, 44, 46, 48, 50, 52

- Ladies' sizes (American - large)

Basic size: **20**

Sizes: 18, 19, **20**, 21, 22, 23, 24, 25, 26

- Ladies' sizes (American)

Basic size: **6**

Sizes: 2, 4, **6**, 8, 10, 12, 14, 16, 18, 20

11.11.01 Selecting the basic size in the INPUT mode



In the **INPUT** mode only basic sizes can be altered. The basic size determines the size system which is to be used. The size system is specifically assigned to the program to be programmed.



- Choose the **programming** or **Teach In** function in the **INPUT** mode.



- Select the **size selection** function.

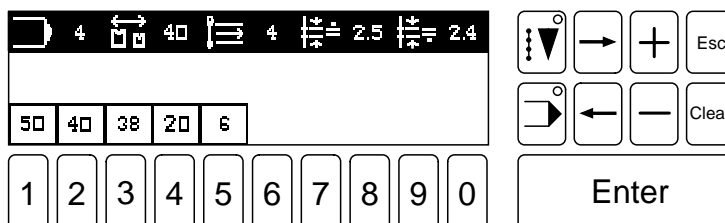

Fig. 11 - 22

- 1 to 5
- Choose the desired basic size.
- Enter
- Confirm selection by pressing the **Enter** key.

11.11.02 Selecting the size in the SEWING mode



In **programed SEWING** the sizes of the respective size system may be selected. The size system is determined by the selected program and has been assigned to the program during programming.



- Choose the **program selection** function in the **SEWING** mode.

- Call up an already programmed seam program (**number keys**).



- Select the **size selection** function.

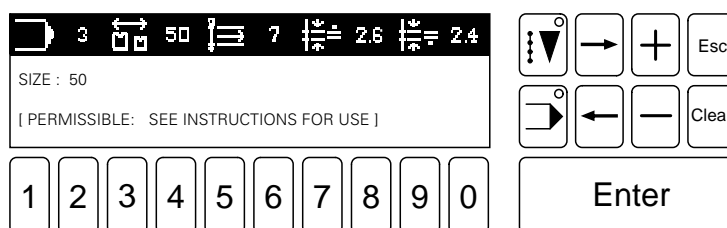

Fig. 11 - 23

- Enter the desired size using the **number keys**.



- Confirm by pressing the **Enter** key.

11.12 Programming examples

11.12.01 Example for programming a seam

- The seam to be programmed must
- consist of 2 seam sections
 - be saved under program number 4
 - with the comment "seam 1".
 - The stitch length must be 2.0 mm.



- Select INPUT mode.

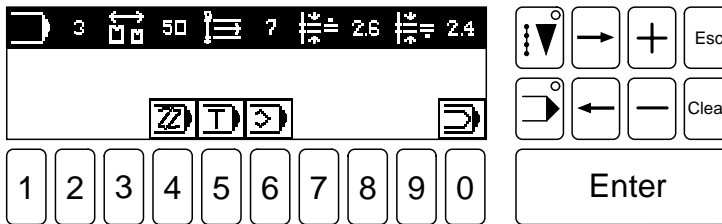

Fig. 11 - 24



- Select programming (number key 4).

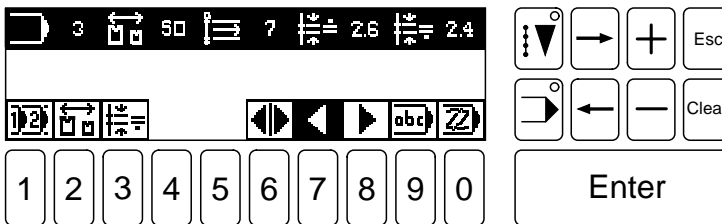

Fig. 11 - 25



- Call up the program selection function (number key 1).

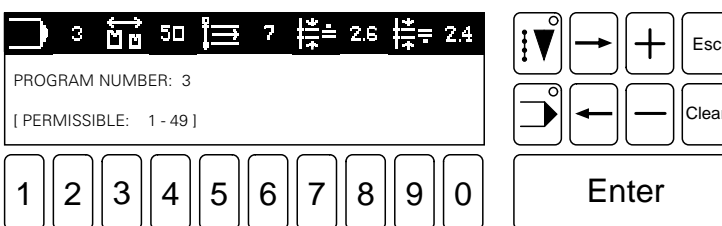

Fig. 11 - 26



- Enter program number 4.



- Confirm by pressing Enter.

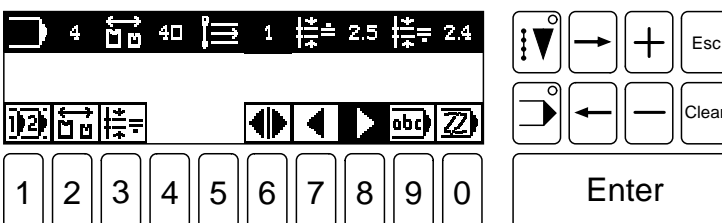

Fig. 11 - 27



- Select the **size selection** function (number key 2).

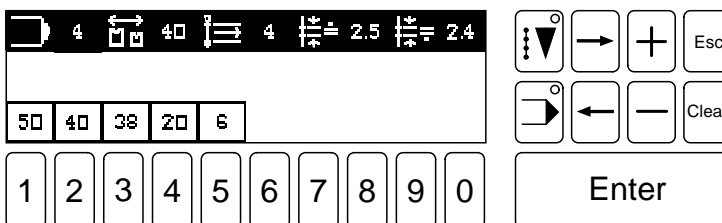

Fig. 11 - 28



- Choose basic size **50** (see chapter 11.11 Selecting the size).



- Confirm by pressing **Enter**.

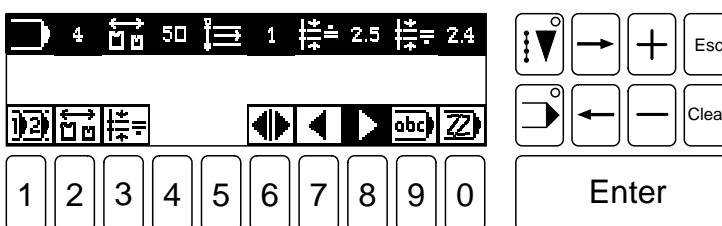

Fig. 11 - 29



- Select **stitch length** (feed wheel) function (number key 3).

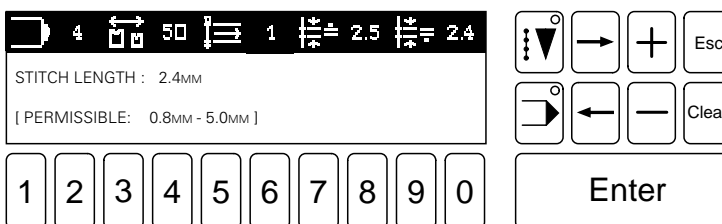

Fig. 11 - 30



- Enter value for the stitch length.



- Confirm by pressing **Enter**.

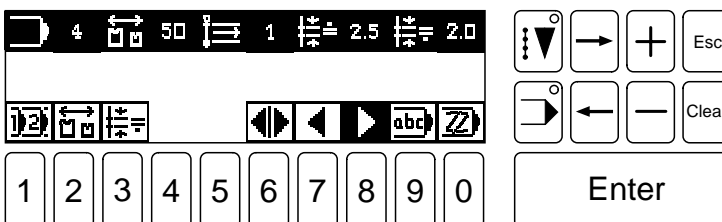

Fig. 11 - 31



- Select the **automatic seam change** function (number key 6).



By activating the **automatic seam change** function, when a seam program is entered, the right seam is first sewn.

After the seam program is completed, the machine switches automatically to input of the left seam.



- Select **comment** function (number key 9).

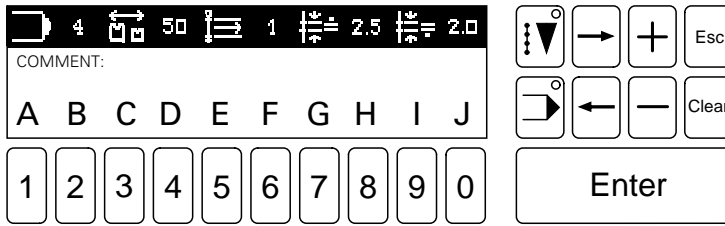

Fig. 11 - 32



- Press right arrow key.

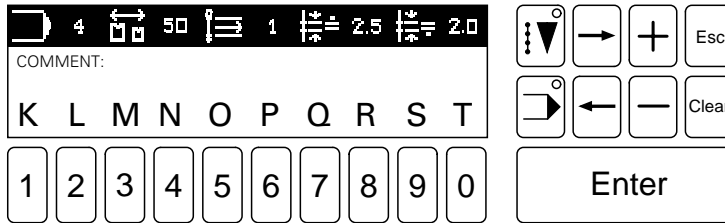

Fig. 11 - 33



- Select the letter N.



- Press left arrow key (display Fig.11-32 appears again).



- Select the letter A.
- Complete comment according to the system shown above.
- Confirm by pressing Enter.

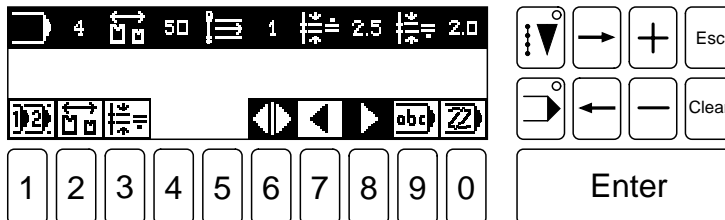

Fig. 11 - 34

After the basic data have been entered, the first seam section can be programmed:

In the first seam section

- the seam length is to be 50 mm
- and the roller presser is to utilize a feed motion of 2.6 mm.



- Select programming function (number key 0).

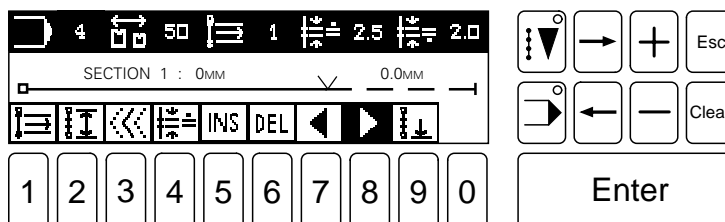

Fig. 11 - 35



- Select seam length function (number key 2).



Fig. 11 - 36



- Enter value for the seam length.

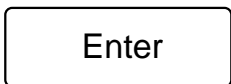

- Confirm by pressing Enter.

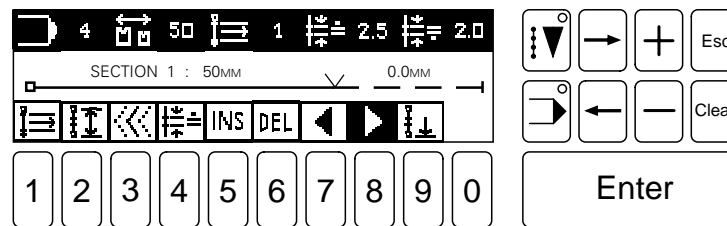

Fig. 11 - 37



- Select function roller presser feed motion (number key 4).

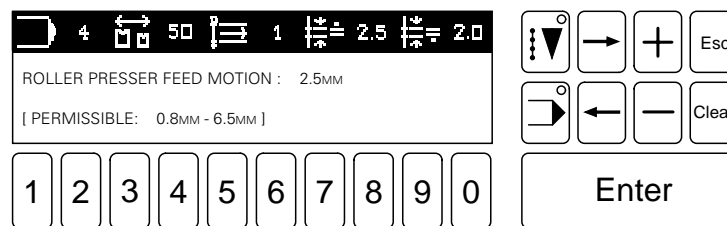
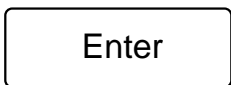

Fig. 11 - 38



- Enter value for the feed motion of the roller presser.



- Confirm by pressing Enter.

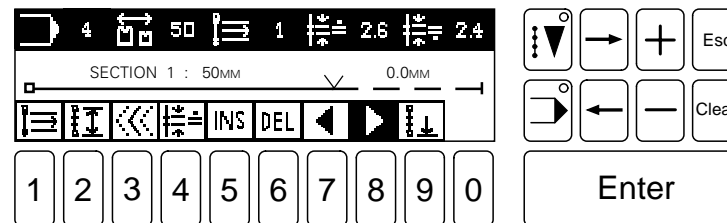

Fig. 11 - 39



- After the input is once again confirmed with **Enter**, the machine switches to input of the second seam section.

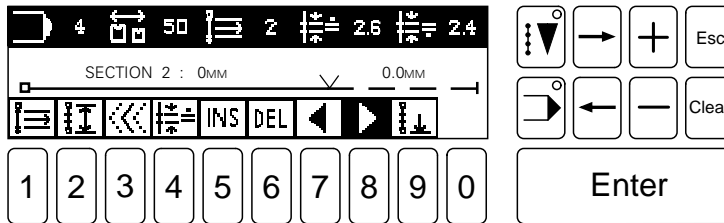

Fig. 11 - 40

In the second seam section

- the seam length is to be 30mm and
- a graduation of 4.0 mm is to be entered.
- The roller presser feed motion is to be taken over unchanged from seam section 1.



- Select **seam length** function.



- Enter value for **seam length**.



- Confirm by pressing **Enter**.



- Select **graduation** function (number key 3).

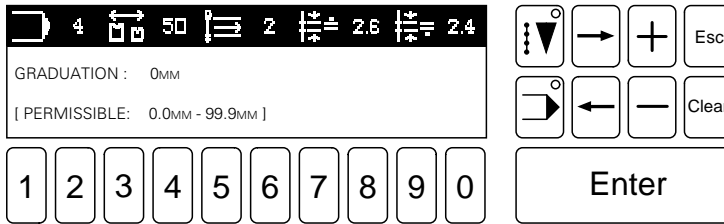

Fig. 11 - 41



- Enter **graduation**.



- Confirm by pressing **Enter**.

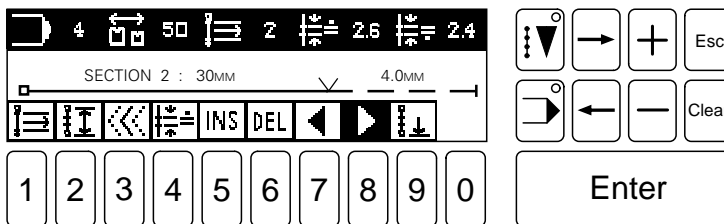

Fig. 11 - 42



- Select **end of seam** function (number key 9).



- By pressing the **Enter** key, you store the seam and jump to the left seam, since the **automatic seam change** function is activated.



- Continue with the inputs for the left seam according to the above example.

- Pressing **Enter** stores the entire seam program.

11.12.02 Example of Teach In programming

The seam to be programmed

- is to have 2 seam sections
- to be stored under program number 5
- with the comment "learn".
- The stitch length is to be 2.4 mm and the basic size 50.



- Select INPUT mode.

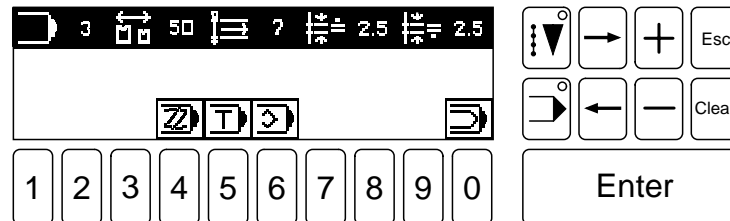

Fig. 11 - 43



- Select the Teach In function (number key 5).

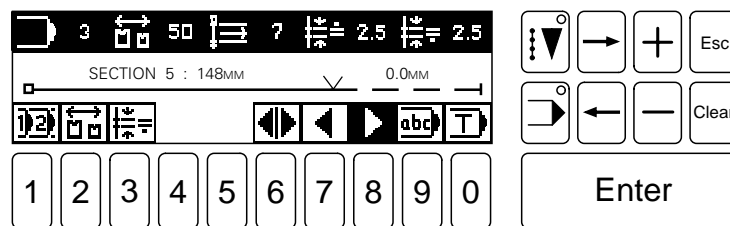

Fig. 11 - 44

- Select the program selection function (number key 1).

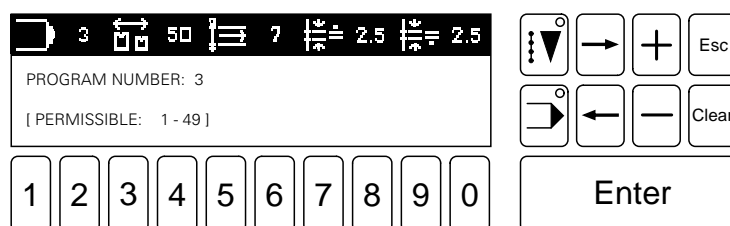

Fig. 11 - 45

- Enter the program number.

- Confirm by pressing Enter.

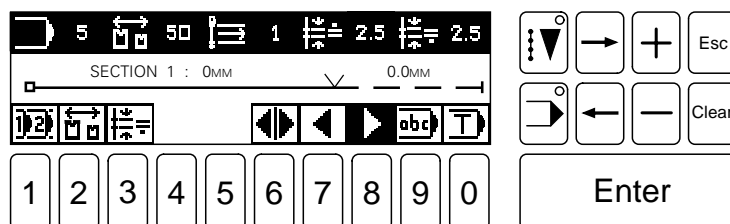
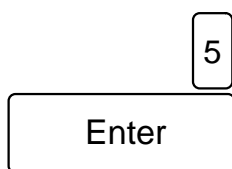

Fig. 11 - 46



- Select size selection function (number key 2).

50

- Select basic size 50 (also refer to chapter 11.11 Selecting the size).

Enter

- Confirm with Enter.



- Select **stitch length** function (feed wheel) (number key 3).

2 4

- Enter the value for the stitch length.

Enter

- Confirm with Enter.



- Select comment function (number key 9).

- Enter comment (see chapter 11.12.01 Example for programming a seam).

- Confirm with Enter.

Enter

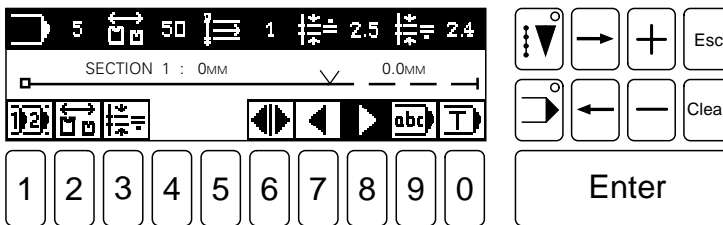

Fig. 11 - 47

After the basic data have been entered, the first seam section can be programmed:

In the first seam section

- the graduation is to be 3.5mm
- and the roller presser is to utilize a feed motion of 3.0 mm.



- Call up the **Teach In** function (number key 0).

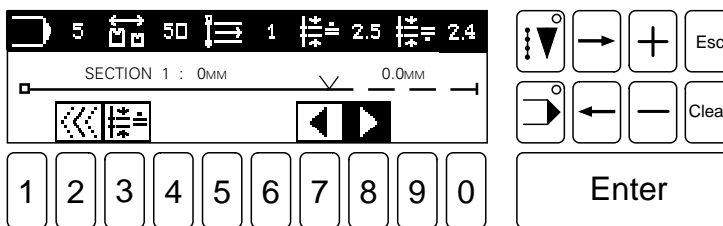

Fig. 11 - 48



- Select **roller presser feed motion** function (number key 3).

3 0

- Enter value for the feed motion.

Enter

- Confirm with Enter.

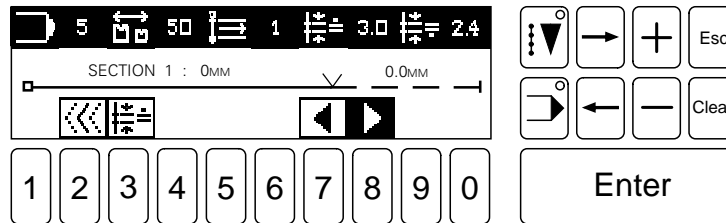

Fig. 11 - 49

- Select graduation function.
- Enter graduation.
- Confirm with Enter.

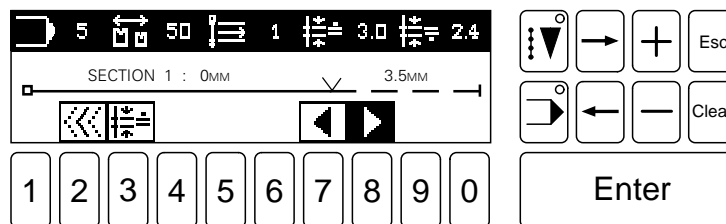

Fig. 11 - 50

- Sew the first seam section. The seam length is thus recorded; when the machine comes to a standstill, it is shown in the display.

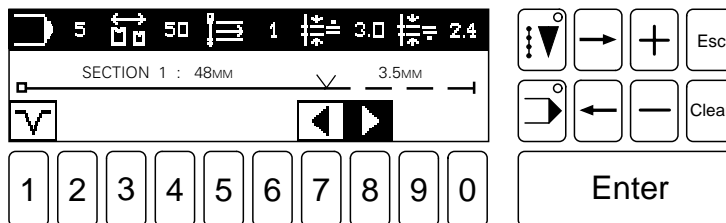

Fig. 11 - 51

- Activating the notch function completes the first seam section. The machine then switches to input of the second seam section.

In the second seam section, the graduation and feed motion remain unchanged.

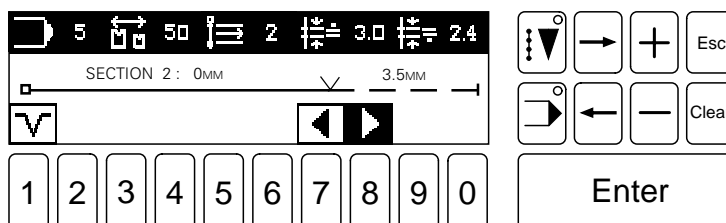

Fig. 11 - 52

- Sew the second seam section.
- After the machine is at a standstill, by trimming the thread (pedal position 3 - see chapter 7.03 Pedal), you end the entire seam program, and it is stored.

12 Care and maintenance

| | |
|---|--|
| Clean | daily, more often if in continuous operation |
| Oil level (lubricating the front parts) | daily, before use |
| Lubricate the hook | daily, before use |
| Lubricate the bevel gears | annually |
| Clean the air filter | once a week |



These maintenance intervals are calculated for the average running time of a single shift operation. If the machine is operated more than this, shorter intervals are recommended.

12.01 Cleaning

Clean the hook and hook compartment daily, more often if in continuous operation.

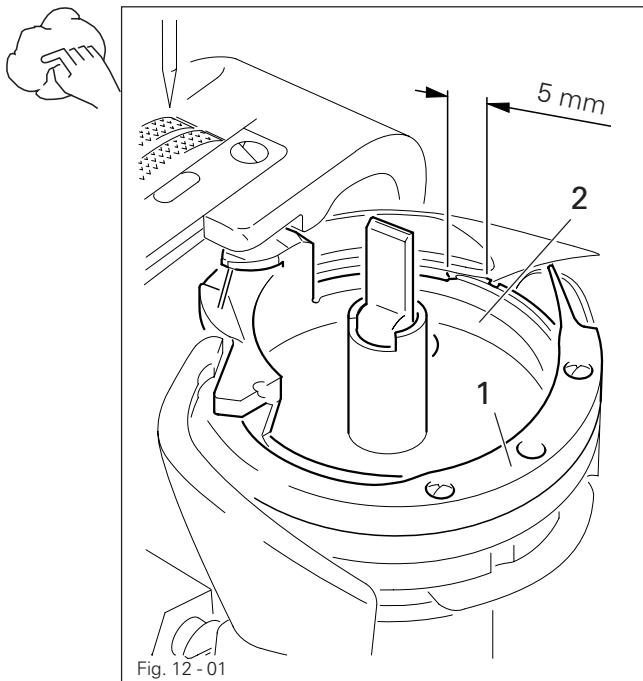

Turn the machine off!

- Bring the needle bar to its highest position.
- Open the post cap and remove the bobbin case cap and the bobbin.
- Unscrew hook gib 1.
- Turn the handwheel until the point of bobbin case 2 penetrates into the groove of the hook race approx. 5 mm.
- Remove bobbin case 2.
- Clean the hook race.
- When inserting the bobbin case 2, ensure that the horn of the bobbin case 2 meshes in the groove of the needle plate.
- Screw hook gib 1 back on and close the post cap.

12.02 Lubricating the hook

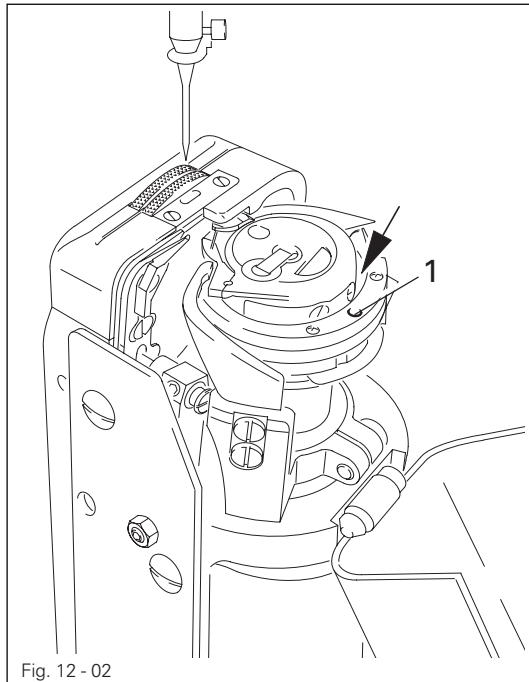

Turn the machine off!

- Apply 1-2 drops of oil into hole 1 of the hook gib every day.
- Before commissioning and after longer standstill periods, also apply a few drops of oil into the hook race. (see arrow in Fig. 12-02)

12.03 Filling the oil reservoir

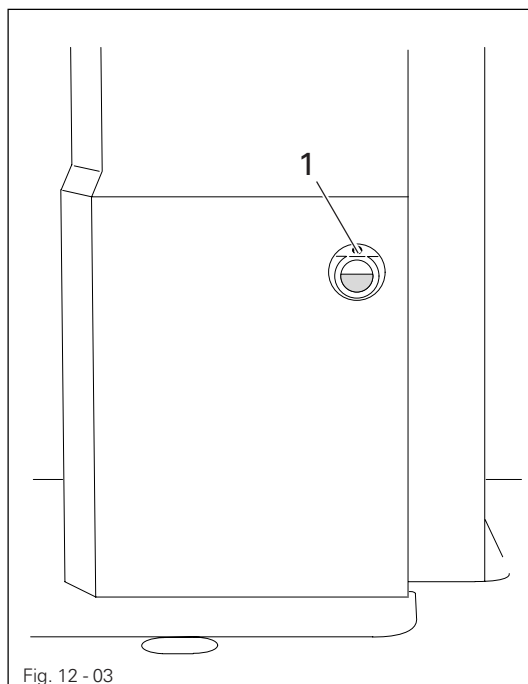

Check the oil level before every use.

- Fill oil through hole 1 into the reservoir as required.



There must always be oil in the oil reservoir.



Use only oil with a mean viscosity of 22.0 mm²/s at 40°C and a density of 0.865 g/cm³ at 15°C.

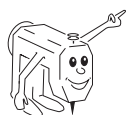

We recommend PFAFF sewing machine oil, part no. 280-1-120 144.

12.04 Cleaning the air filter on the control box

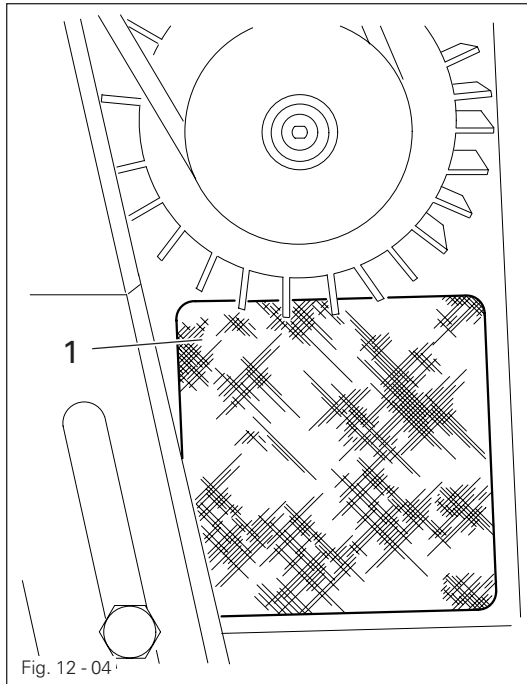

Turn the machine off!

- The filter must be cleaned at least once a week, or more often depending on how clean the air is.
- Dust which collects on the filter grate 1 is to be removed with a brush.



Avoid the use of compressed air which could blow the dust off the filter grate into the machine housing!

12.05 Lubricating the bevel gears

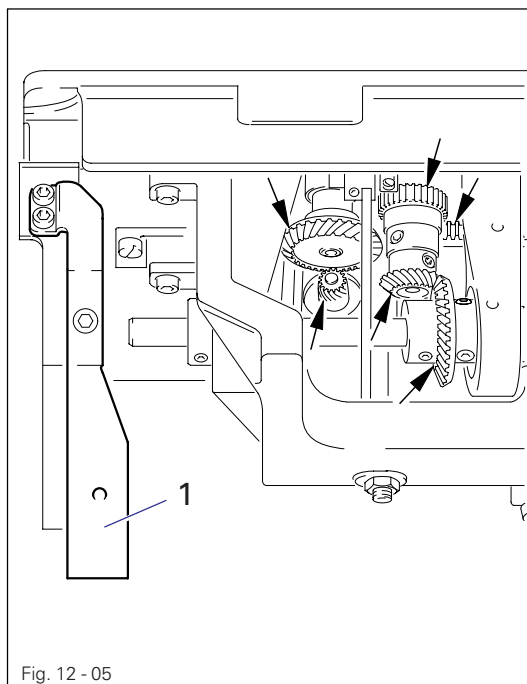

Turn the machine off!

- The bevel gears for driving the hook and the rack are to be greased once a year.
- Disassemble the power table.
- Lay the machine head backwards onto its support.
- Brush a little grease onto all of the tooth flanks and the rack (see arrows).
- To stand the machine head up again, press safety plate 1 to the rear and stand the machine head up using both hands.



Use both hands to return the machine to an upright position. Danger of being crushed between machine head and table top.

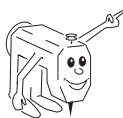

We recommend PFAFF hard soap grease with a dripping point of approx. 150°C
Part no. 280-1-120 243.

13 Adjustment

13.01 Notes on adjusting

All adjustments in these adjustment instructions are based on a completely installed machine and must only be carried out by appropriately trained specialists. Covers on the machine which have to be removed and replaced for checks and adjustment work are not mentioned here. The screws and nuts in brackets () are attachments of machine parts which are to be loosened before making the adjustment and tightened again after the adjustment is finished.

13.02 Tools, gauges and other accessories for adjusting

- 1 set of screwdrivers with blade widths from 2 to 10 mm
- 1 set of wrenches with jaw widths from 7 to 13 mm
- 1 set of Allan keys from 1.5 to 6 mm
- 1 adjustable clamp (Part No. 08-880 137-00)
- 1 metal rule (Part No. 08-880 218-00)
- 1 adjustment pin (needle position in sewing direction, Part No. 61-111 641-46)
- 1 adjustment gauge (Part No. 08-880 136-01)
- 1 adjustment gauge, (Part No. 61-111 643-33)
- 1 adjustment pin for needle bar rise, (Part No. 61-111 641-39)
- Needles, system 134-35 R
- Sewing thread and test material

13.03 Abbreviations

TDC = top dead center

BDC = bottom dead center

Adjustment

13.04 Adjusting the basic machine

13.04.01 Adjusting the synchronizer

Requirement

When the point of the needle is at the top edge of the needle plate, the reference point must be at "0".

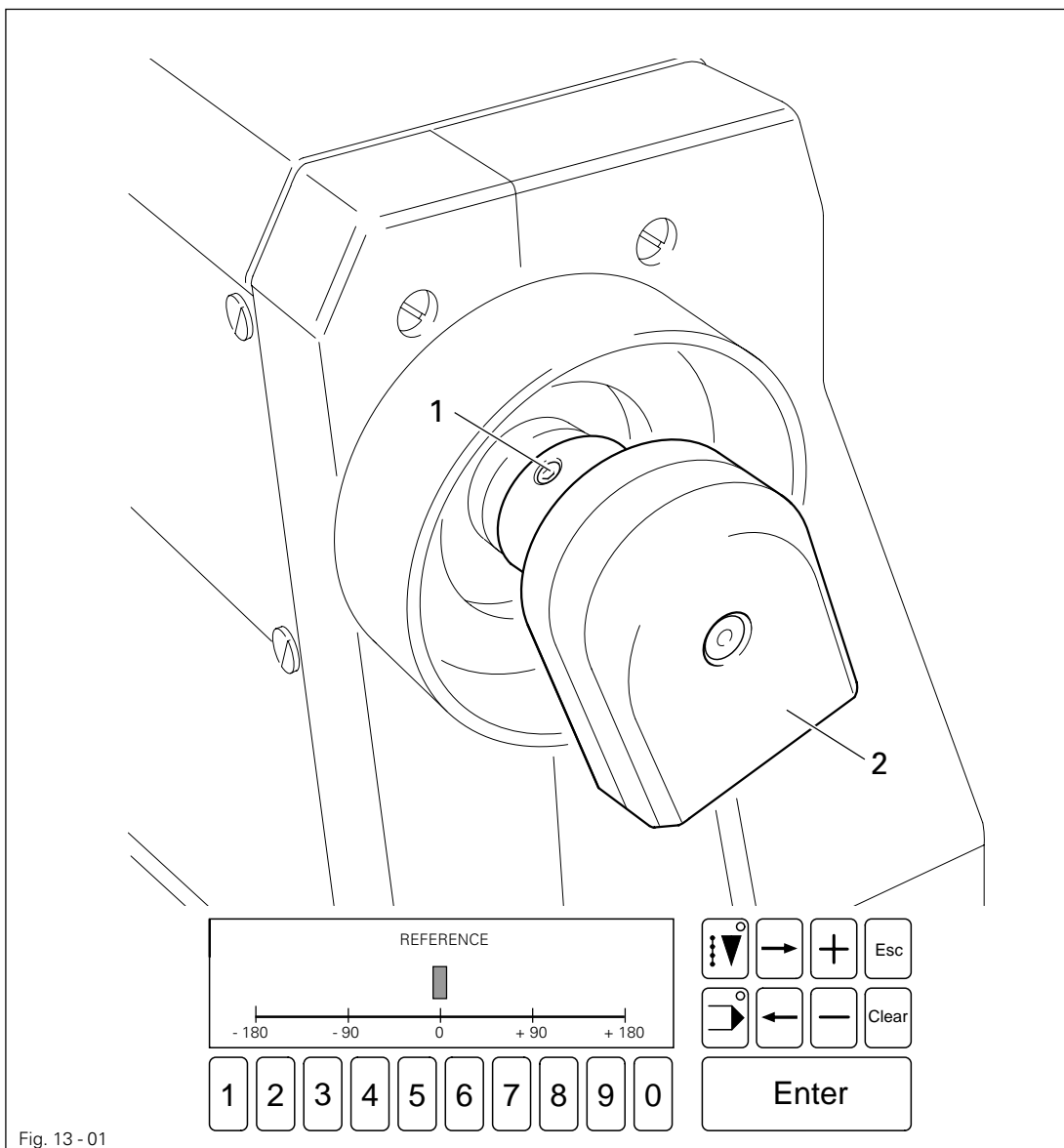
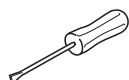

Fig. 13 - 01



- Switch the machine on and sew a few stitches.
- Loosen screws 1.



- Select INPUT mode.



- Select the **input menu** function (number key 0).



- Select the SERVICE function.

2

- Select the SEWING MOTOR function.

1

- Select the ADJUST SYNCHRONIZER function.
- Turn the handwheel in the direction of sewing until the point of the needle is at the top edge of the needle plate.
- With the needle in this position, turn synchronizer 2 until the cursor in the display is at "0".
- Tighten screws 1.



For other positioning options see the ADJUSTING POSITIONS function in **chapter 11.08 Summary of the service functions.**

Adjustment

13.04.02 Positioning the needle in the direction of sewing

Requirement

The needle must penetrate the middle of the needle hole as viewed in the direction of sewing.

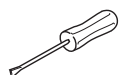
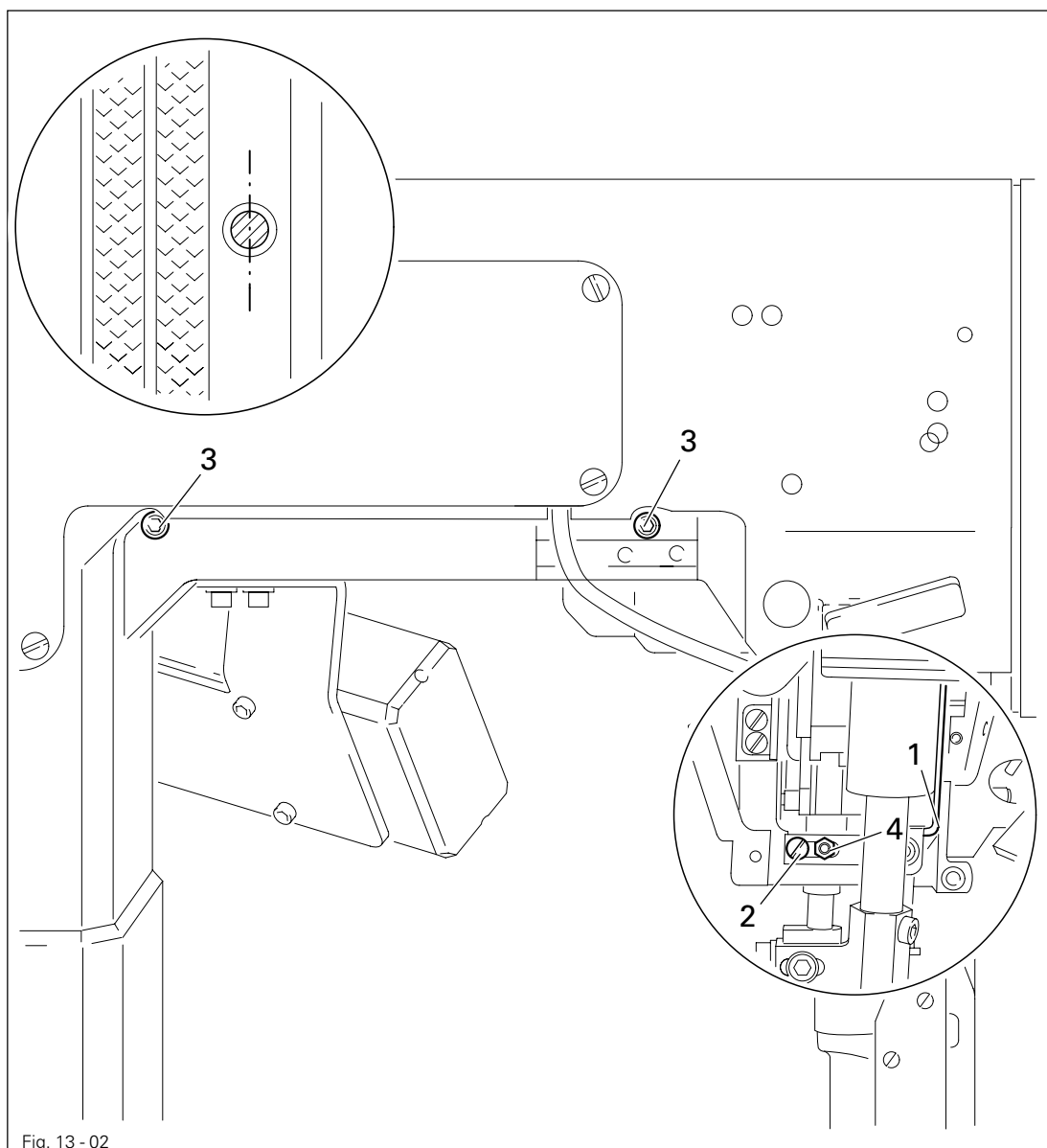

- Move the needle bar frame 1 (screws 2 and 3 and nut 4) in accordance with the requirement.



Screws 3 are accessible through the holes on the back of the housing.

13.04.03 Positioning the needle across the direction of sewing

Requirement

The needle must penetrate the middle of the needle hole as viewed across the direction of sewing.

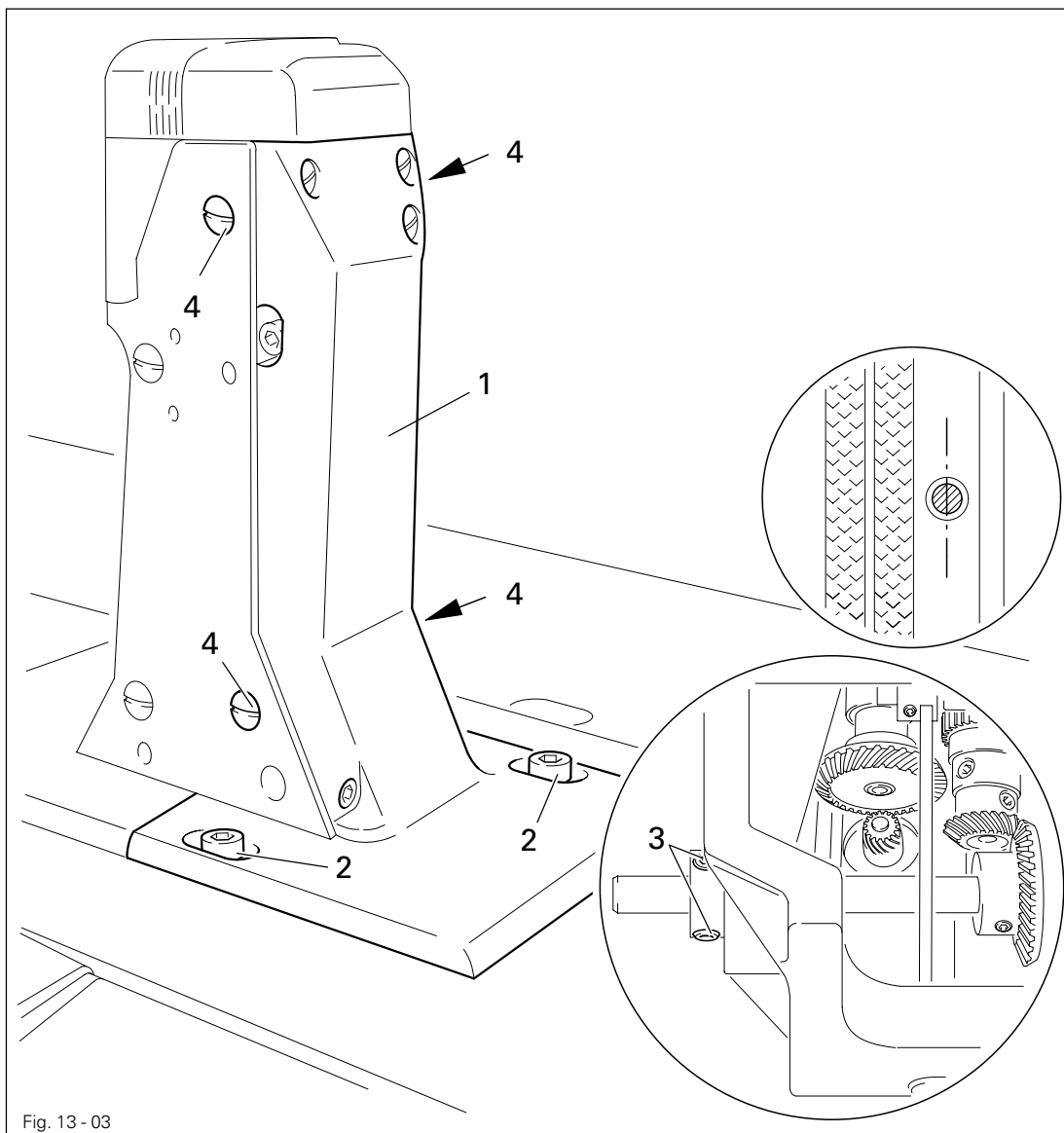
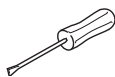

Fig. 13 - 03



- Move the feed wheel post 1 (screws 2, 3 and 4) in accordance with the **requirement**.



Screws 4 remain loosened for the following adjustments.

Adjustment

13.04.04 Preadjusting the needle height

Requirement

With the needle bar at TDC there must be approx. **22 mm** between the point of the needle and the needle plate.

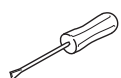
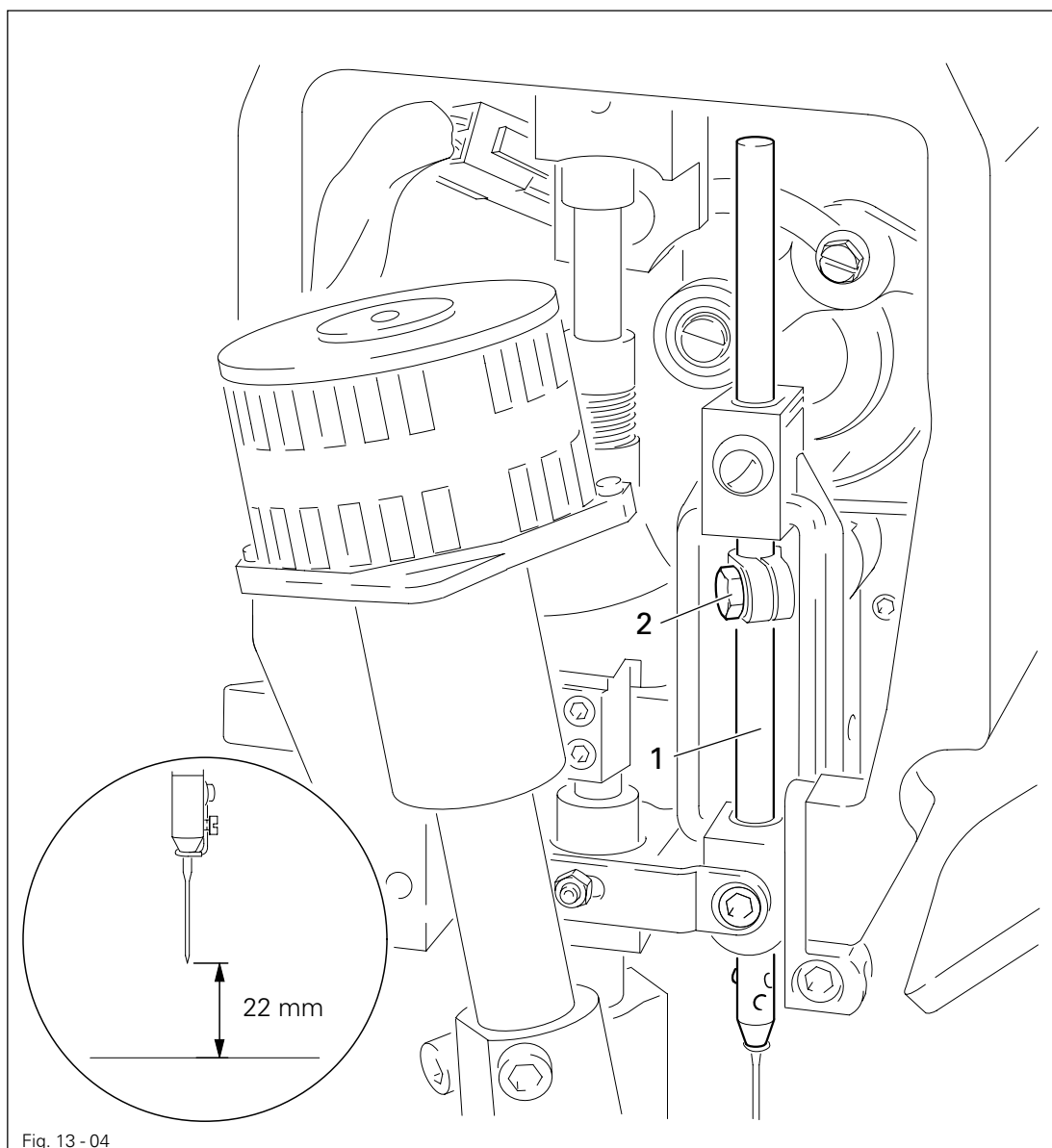

- Move the needle bar 1 (screw 2) in accordance with the requirement without turning it.

13.04.05 Needle rise, hook-to-needle clearance, needle height and needle guard

Requirement

With the needle at 1.8 after BDC

1. the hook point must point to the middle of the needle and be **0.05 to 0.1 mm** from the needle,
2. the top edge of the needle eye must be **0.8 to 1.0 mm** beneath the hook point and
3. the needle guard **9** must lightly touch the needle.

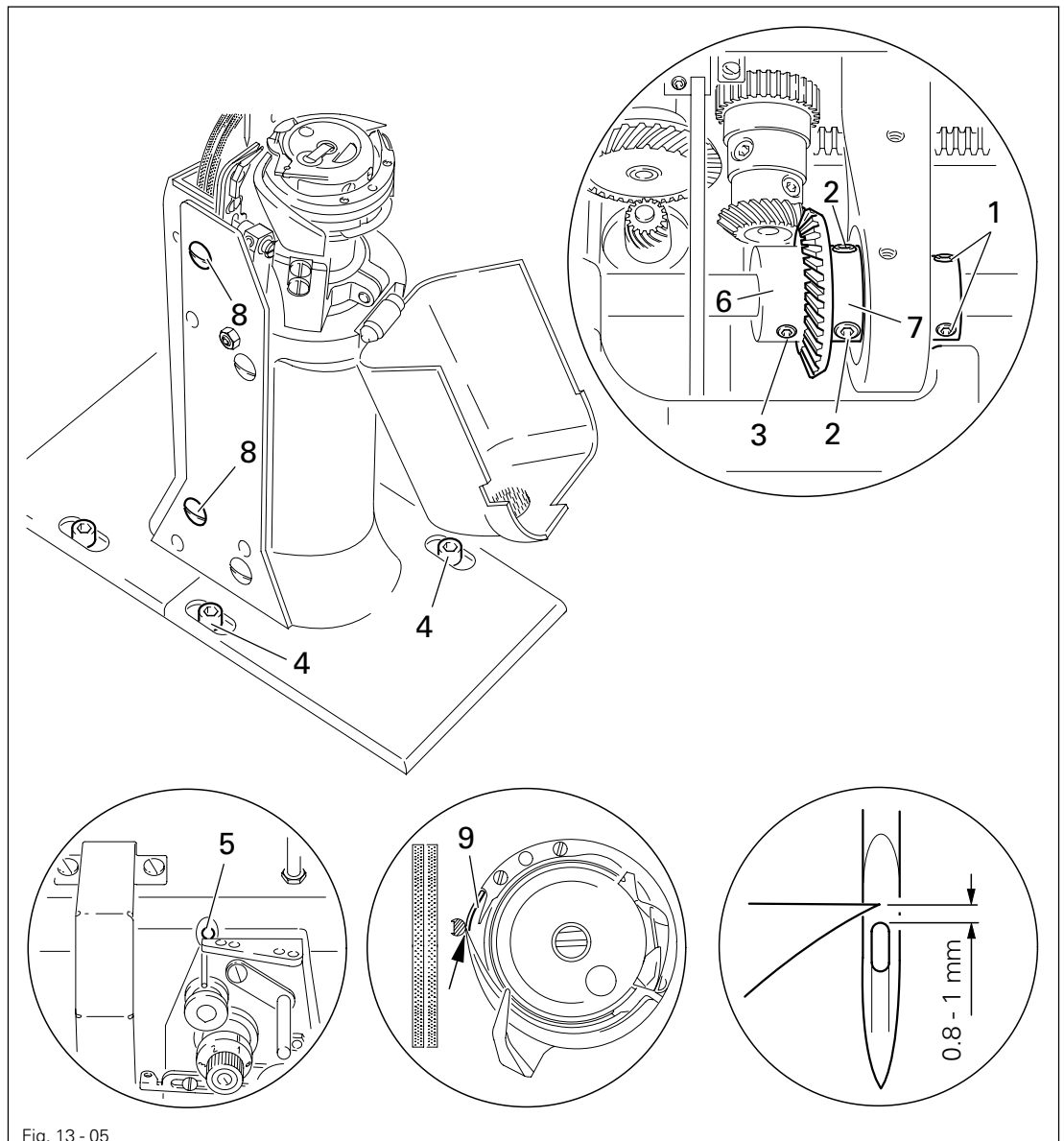
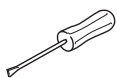

Fig. 13 - 05



- Loosen screws **1, 2, 3** and **4**.
- Position the needle bar **1.8** after BDC.
- Place the adjustment pin into hole **5** and place under pressure.
- Position the hook point at the middle of the needle, taking care to ensure that the needle is not pressed against by the needle guard **9**.
- Set the needle height in accordance with **requirement 2**.
- Move the hook post in accordance with **requirement 1** and tighten screws **4**.

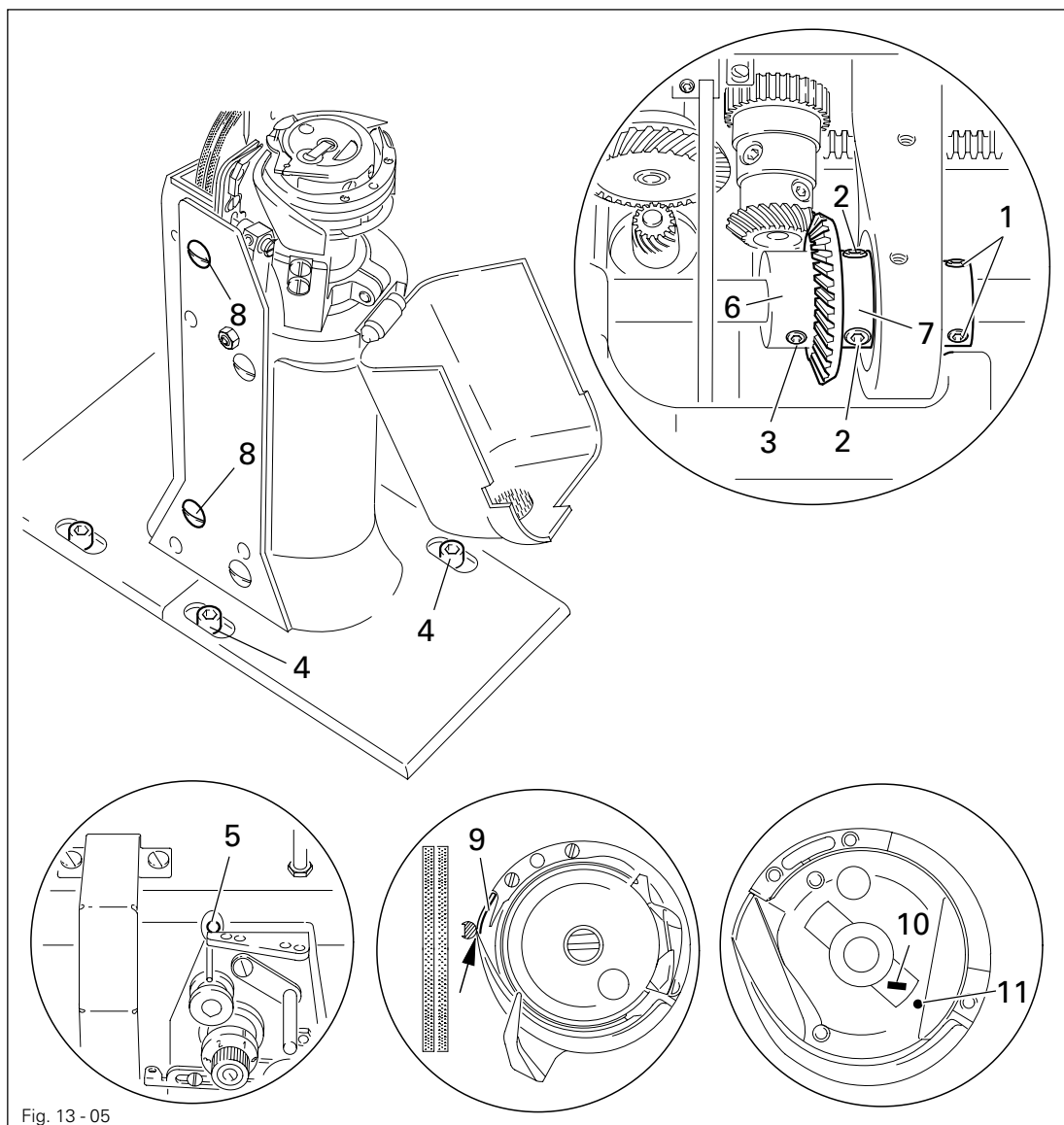

Fig. 13 - 05

- Pull the adjustment pin out of hole 5.
- Observing the bevel gear play, tighten screws 2.
- Bring retaining collar 6 to rest against bevel gear 7 and tighten screws 1 and 3.
- Tighten screws 8 on both sides of the post.
- Align needle guard 9 in accordance with **requirement 3**.



When changing the hook, ensure that markings 10 and 11 are both on the same side.

13.04.06 Bobbin case opener height

Requirement

The top edges of the bobbin case opener **1** and the bobbin case base **3** must be at the same height.

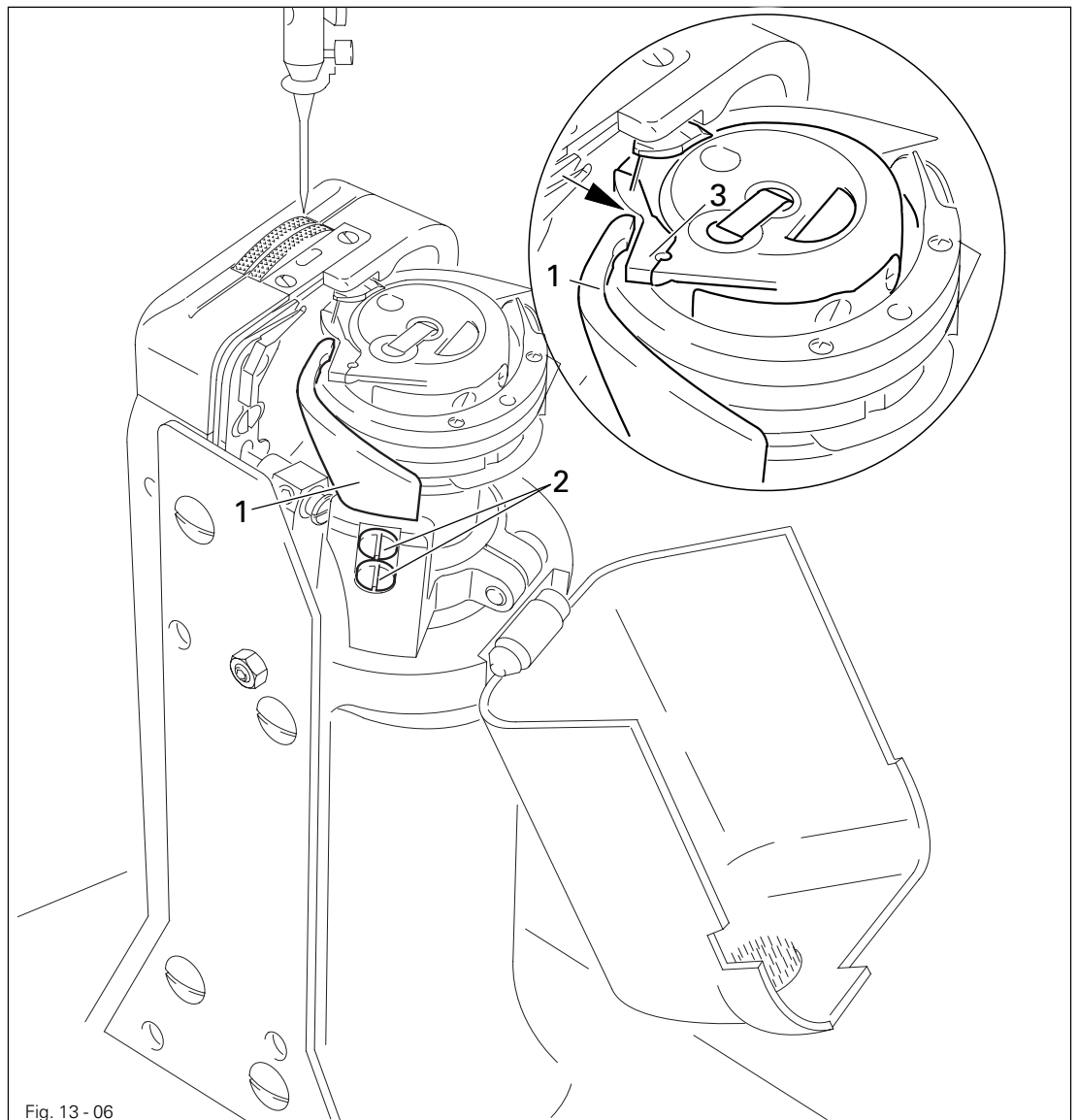
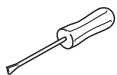

Fig. 13 - 06



- Move the bobbin case base **1** (screws **2**) in accordance with the **requirement**.

13.04.07 Bobbin case opener stroke

Requirement

When the bobbin case opener presses the bobbin case to the furthest extent, the projection of the bobbin case must protrude **0.3 - 0.5 mm** from the rear edge of the needle plate recess.

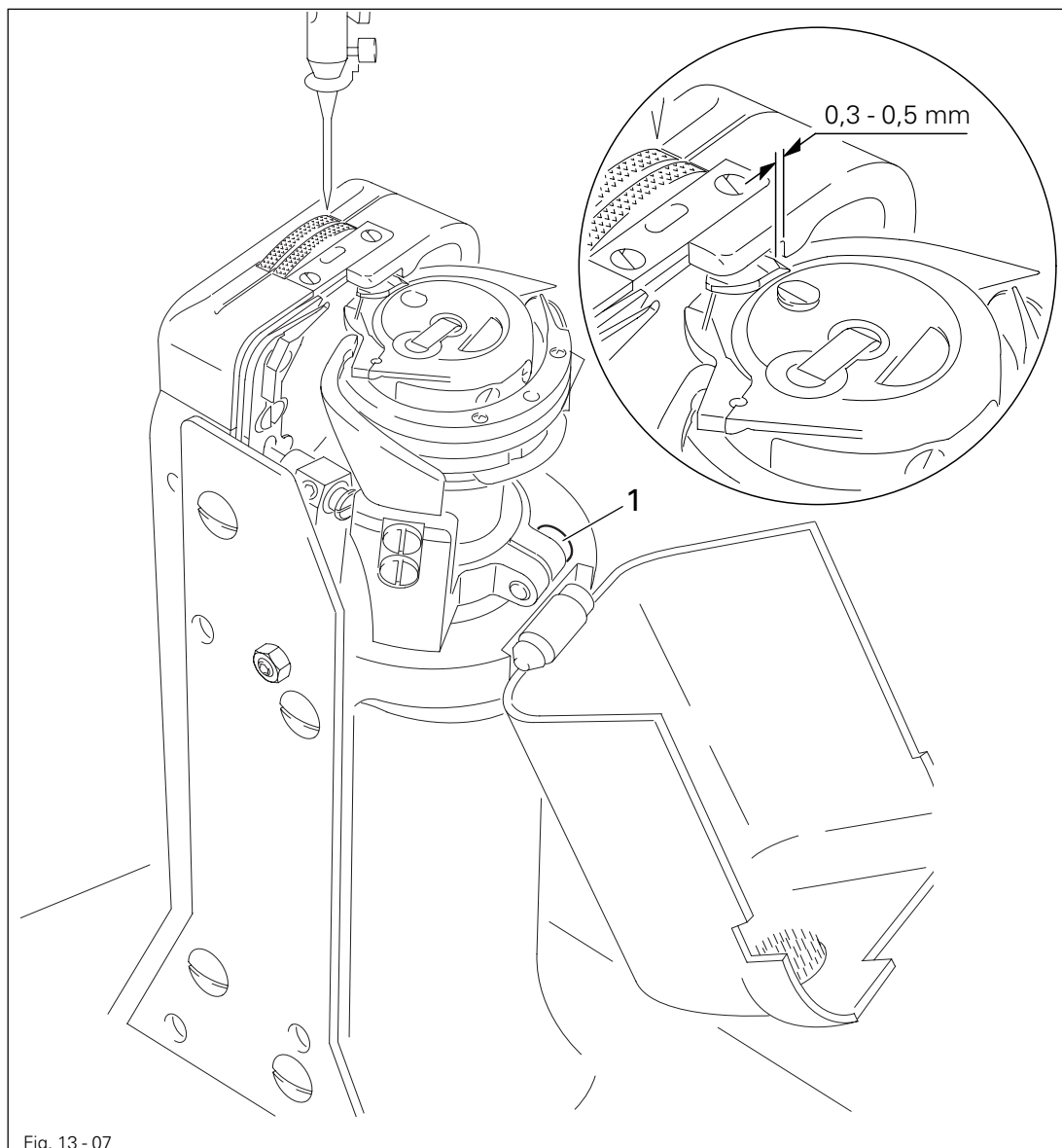
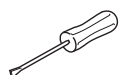

Fig. 13 - 07



- Turn the handwheel until the bobbin case opener presses against the bobbin case to the furthest extent.
- Move the bobbin case base (screw 1, accessible from the rear of the post) in accordance with the **requirement**.



This setting can vary according to the thickness of the thread.

13.04.08 Feed wheel height

Requirement

On the **3834-4/11** the feed wheel should project approx. **0.8 mm** from the needle plate and **0.4 mm** on the **3834-4/21**.

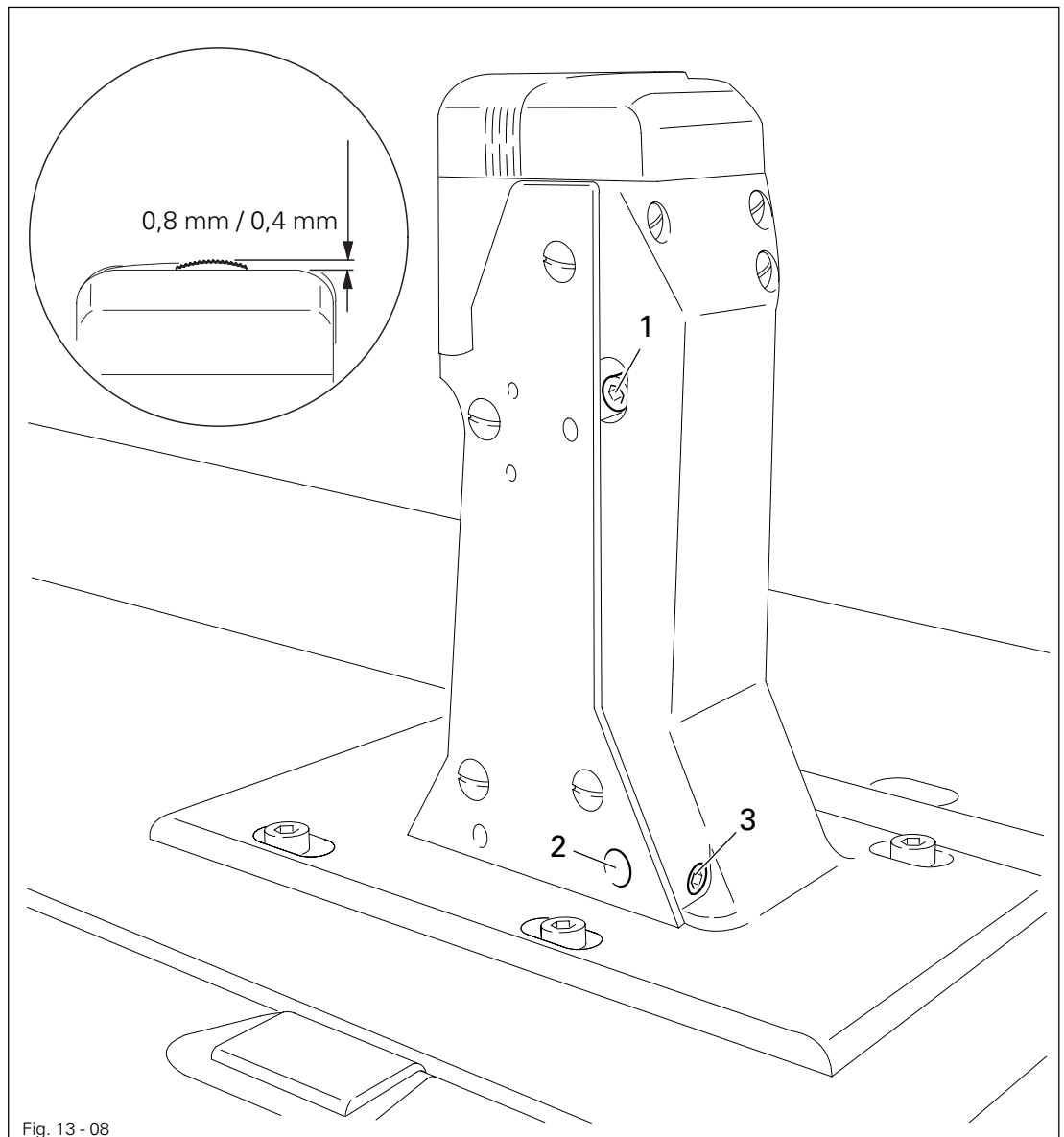
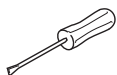

Fig. 13 - 08



- Swing out the roller presser.
- Loosen screw **1**.
- Turn the eccentric (screw **3**) which is accessible through hole **2** in accordance with the requirement.
- Tighten screw **1**.

13.04.09 Clearance between the roller presser or band feed and the feed wheel

Requirement

When lever 1 is raised, there should be a clearance of **7 mm** between the roller presser and the feed wheel or the band feed.

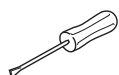
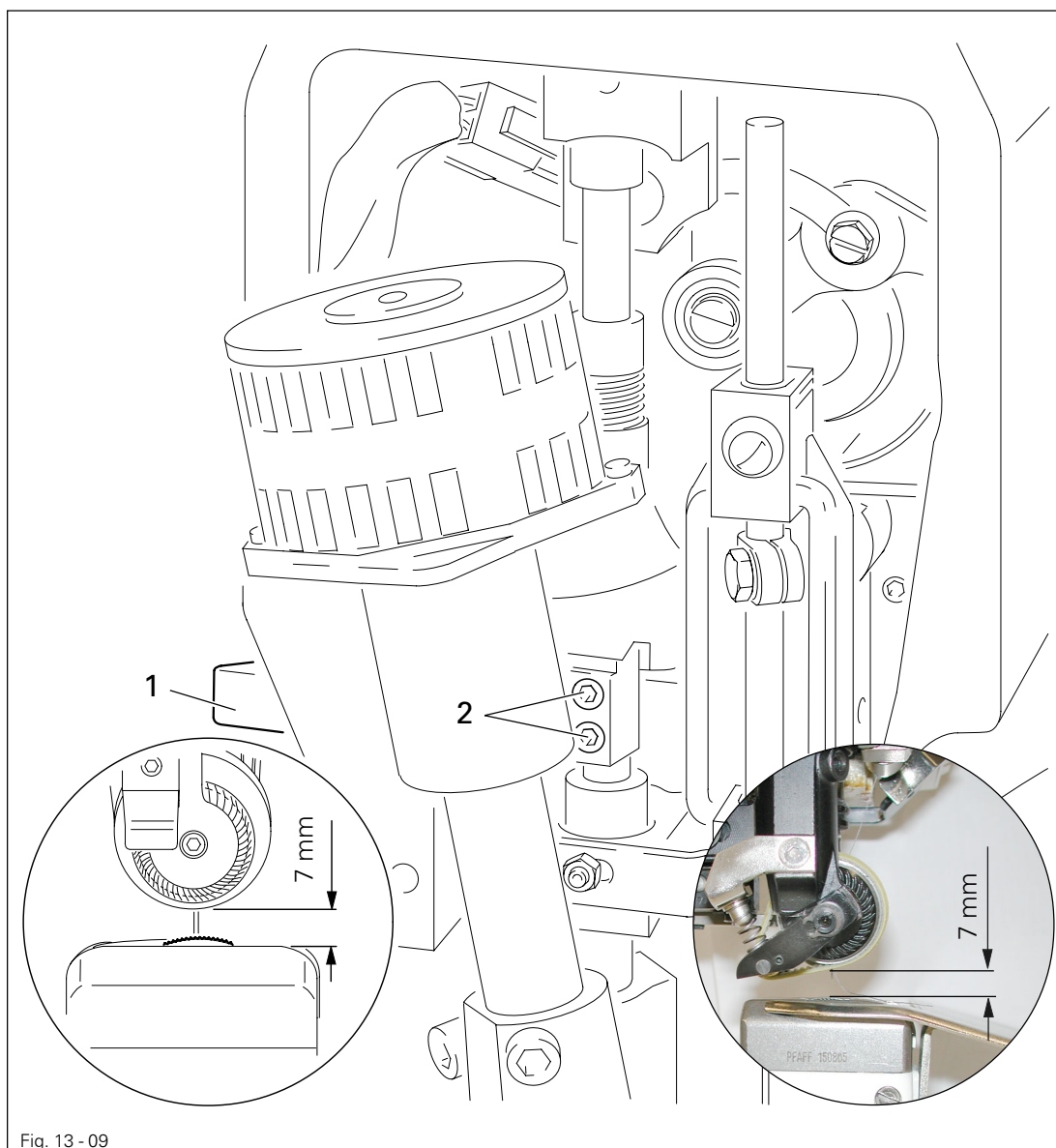

- Raise lever 1.
- Adjust the presser bar (screws 2) in accordance with the **requirement**. Make sure that the roller presser or the band feed is parallel to the feed wheel.

13.04.10 Roller presser (3834-4/11)

Requirement

When the roller presser **1** is resting on the feed wheel **5** it must

1. be parallel to the feed wheel **5** when viewed in the direction of sewing,
2. be centered with respect to the needle when viewed in the direction of sewing and
3. be as close as possible to the needle when viewed across the direction of sewing.

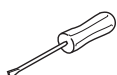
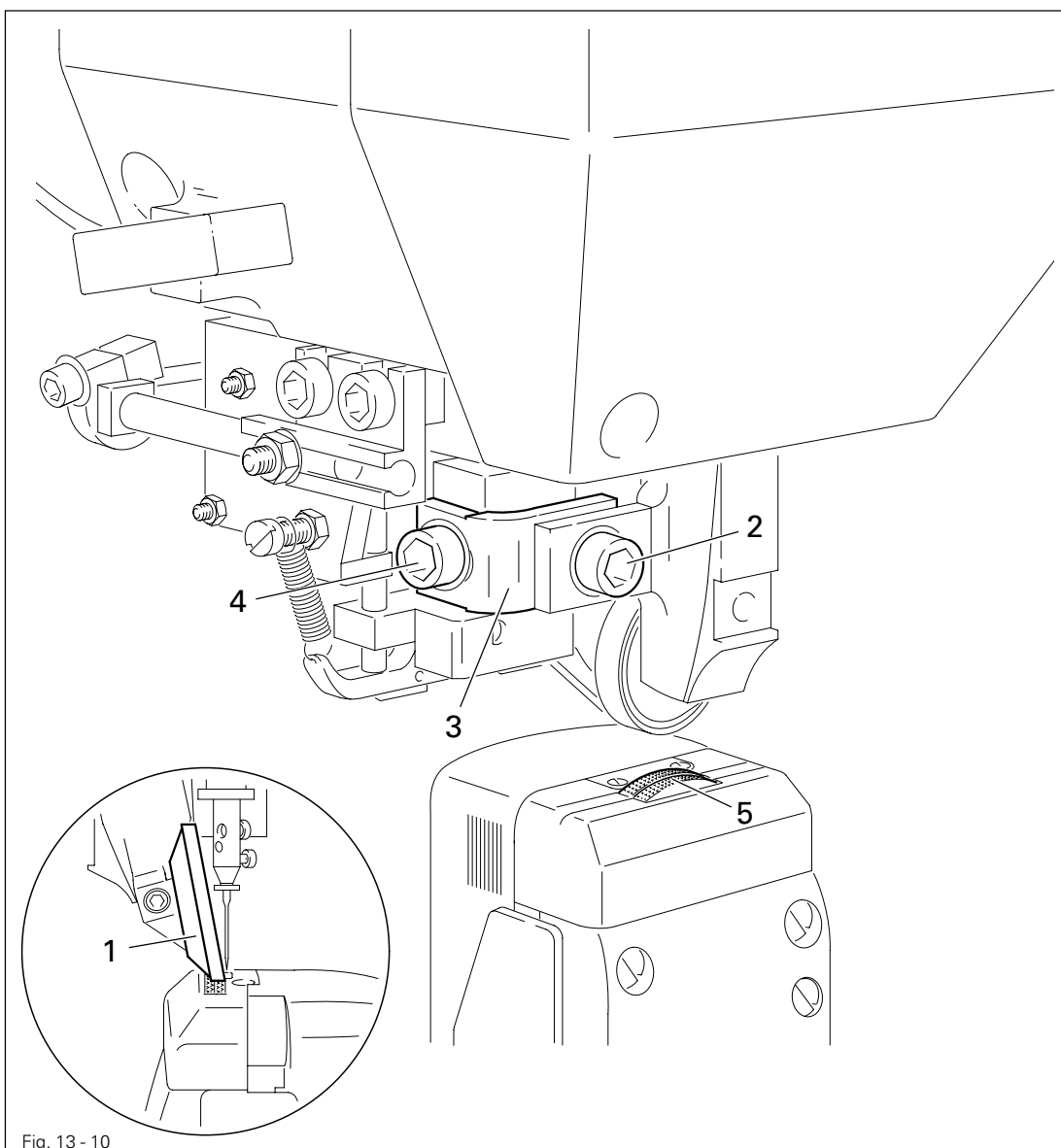

- Raise the roller presser **1**.
- Always observe **requirement 1** when carrying out the following adjustments.
- Move the roller presser **1** (screw **2**) in accordance with **requirement 2**.
- Allow the roller presser **1** to come to rest on the feed wheel **5**.
- Move the roller presser bracket **3** (screw **4**) in accordance with **requirement 3**.



When sewing very tight curves the roller presser **1** should be moved toward the operator slightly.

13.04.11 Band feed (3834-4/21)

Requirement

Band feed **5** should be set so that

1. The centre of roller **6** is approx. **2.5 mm** from the centre of feed wheel **7**
2. The band feed **5**, seen in the direction of sewing, is parallel to feed wheel **7** and the seam runs directly below O-ring **8**.

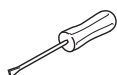
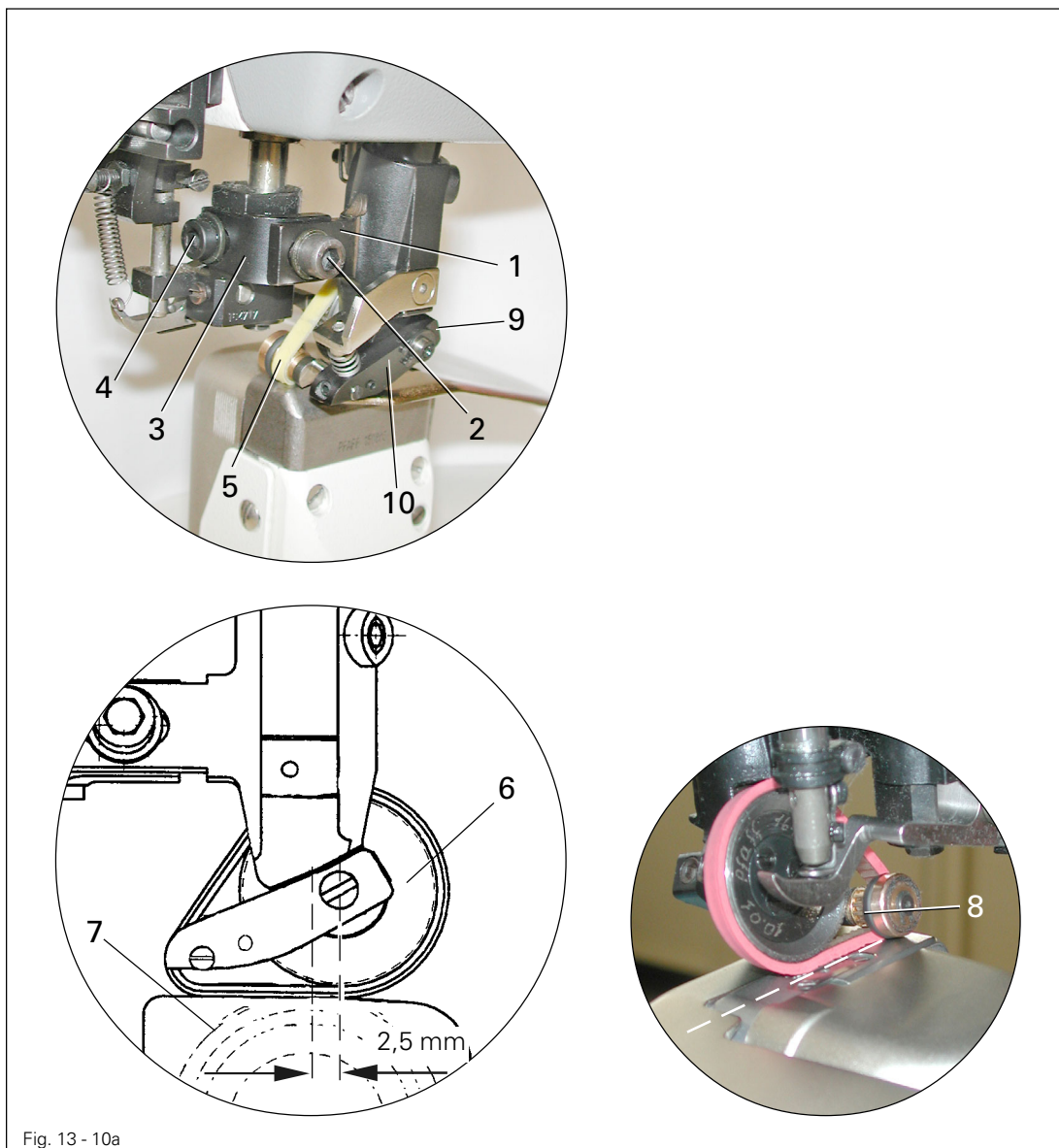

- Adjust holder **1** (screw **2**) in accordance with **requirement 1**.
- Adjust holder **3** (screw **4**) in accordance with **requirement 2**.

13.04.12 Changing the band (3834-4/21)

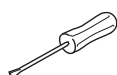

- Turn eccentric 1 (screw 2) towards the inside.
- Fit feed band 3 and tighten with eccentric 1.
- Tighten screw 2.

Part no.

Feed band 91-189 210-95

O-ring 15-120 723-05

Adjustment

13.04.13 Automatic presser-foot lifter

Requirement

When solenoid 1 is activated, lever 3 for the roller presser must drop automatically.

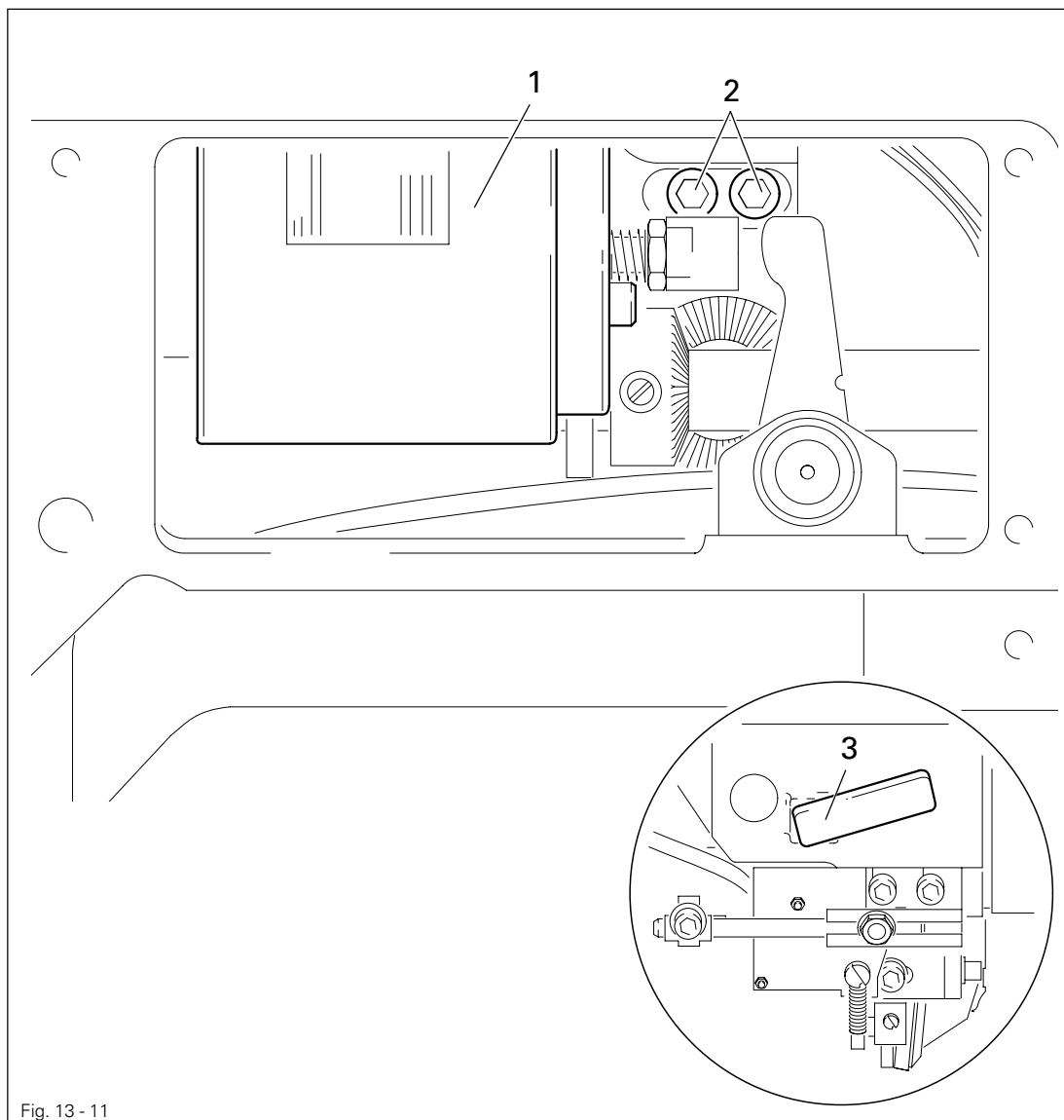
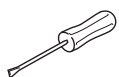

Fig. 13 - 11



- Move solenoid 1 (screws 2) in accordance with the **requirement**.
- Turn the machine on and check the **requirement**.
- Turn the machine off.



Depending on the thickness of the material, the clearance between the roller presser and the feed wheel can be increased to a maximum of **10 mm** by moving the solenoid 1 to the right.

13.04.14 Holding-down clamp

Requirement

The holding-down clamp **3** must lie flat on the material. The material must not start to flag when sewing.

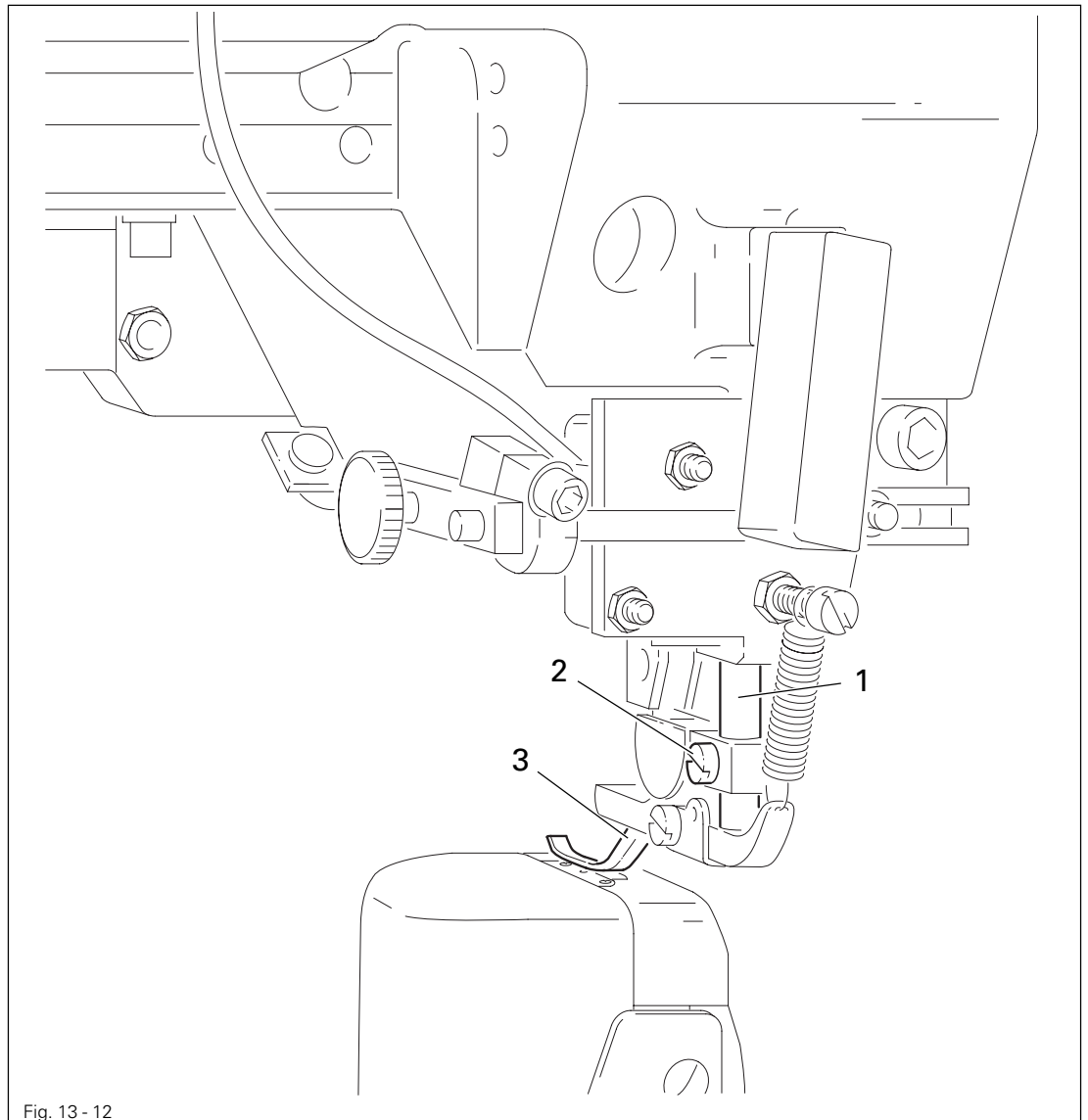
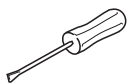

Fig. 13 - 12



- Adjust pin **1** (screw **2**) according to **requirement**.

Adjustment

13.04.15 Tension release

Requirement

With lever 1 raised or the automatic presser foot lifter activated, both tension discs 6 must be at least 0.5 mm apart.

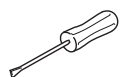
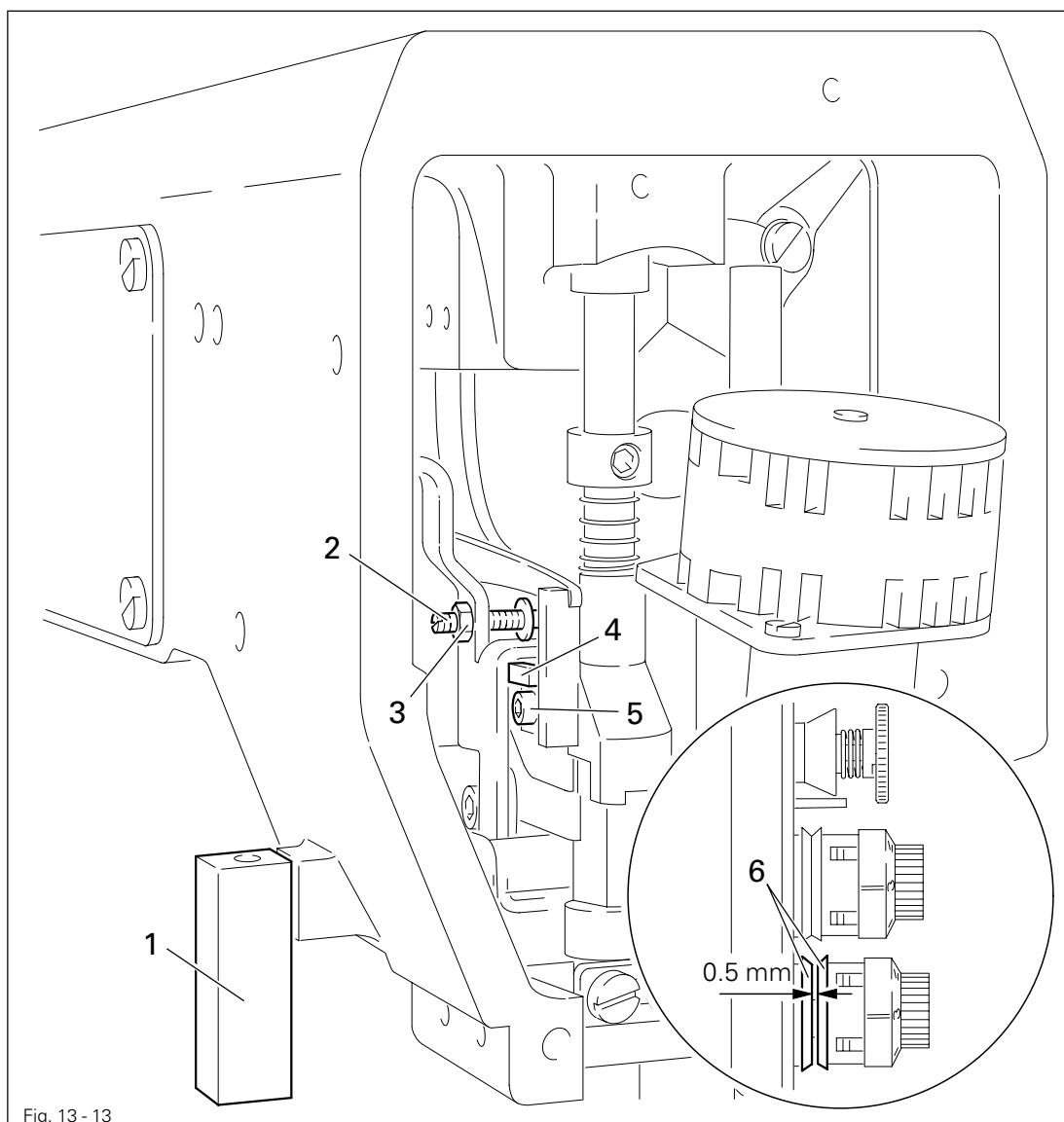

- Raise the roller presser using lever 1.
- Adjust screw 2 (nut 3) according to the **requirement**.
- Raise the roller presser using the automatic presser foot lifter or the knee lever.
- Move the drive dog 4 (screw 5) according to the **requirement**.

13.04.16 Thread check spring

Requirement

1. The motion of the thread check spring **7** must be completed when the needle point enters the material (spring stroke approx. **7 mm**).
2. With the thread loop at its largest when it is guided around the hook, the thread check spring must be raised slightly above the workpiece rack **1**.

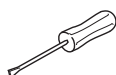
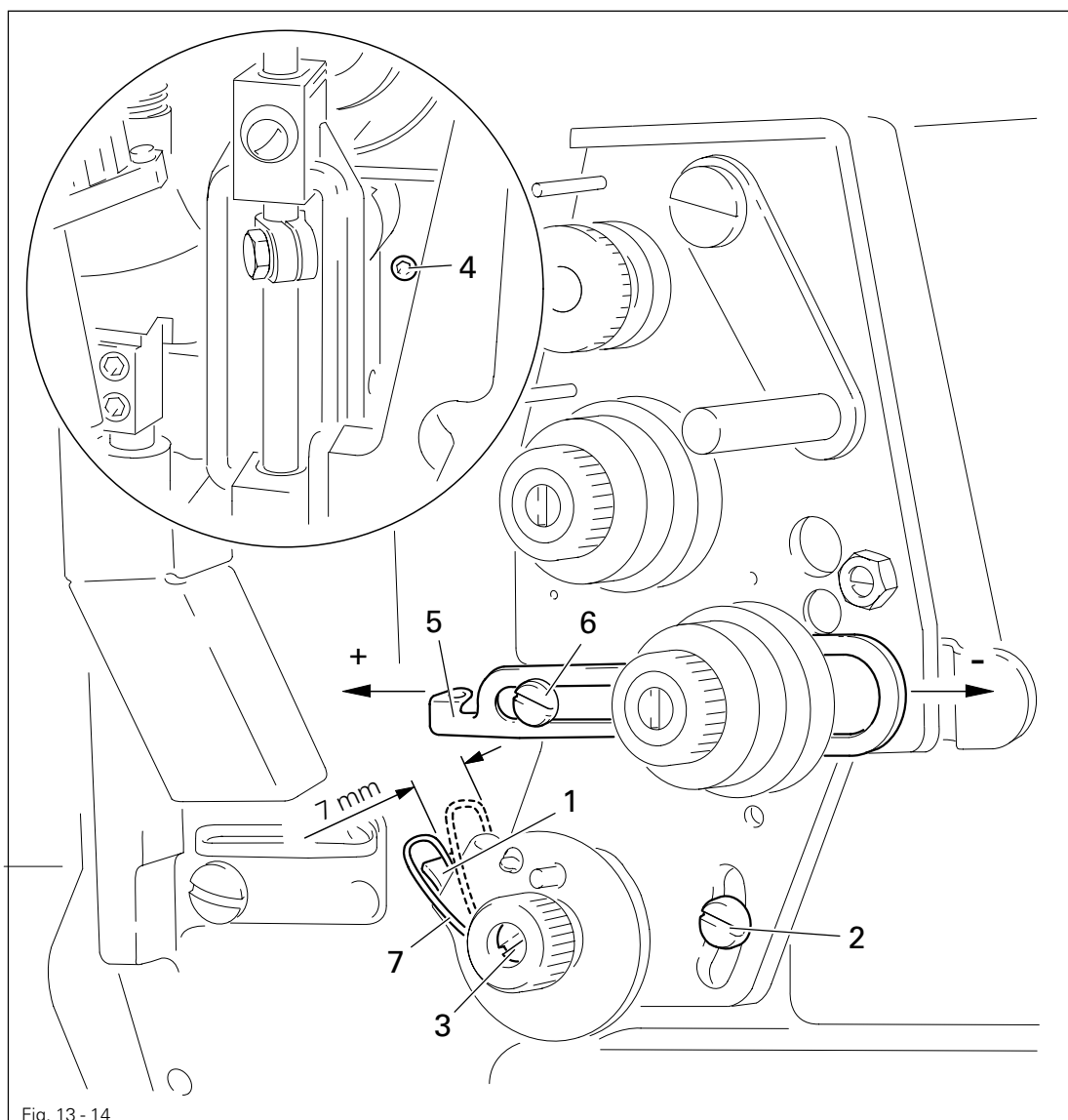

- Move workpiece rack **1** (screw **2**) in accordance with **requirement 1**.
- Turn screw **3** (screw **4**) to adjust the tension of the spring.
- Move the slack thread regulator **5** (screw **6**) in accordance with **requirement 2**.



Due to technical sewing reasons it may be necessary to deviate from the spring stroke / spring tension described above.

Adjust the slack thread regulator **5** (screw **6**) in the direction of the " + " (= more thread) or the " - " (= less thread).

13.04.17 Bobbin winder

Requirement

1. With the bobbin winder on, the bobbin winder spindle must engage reliably. With the bobbin winder off, the friction wheel **5** must not engage the drive wheel **1**.
2. The bobbin winder must turn off automatically when the thread level is approx. **1 mm** from the edge of the bobbin.

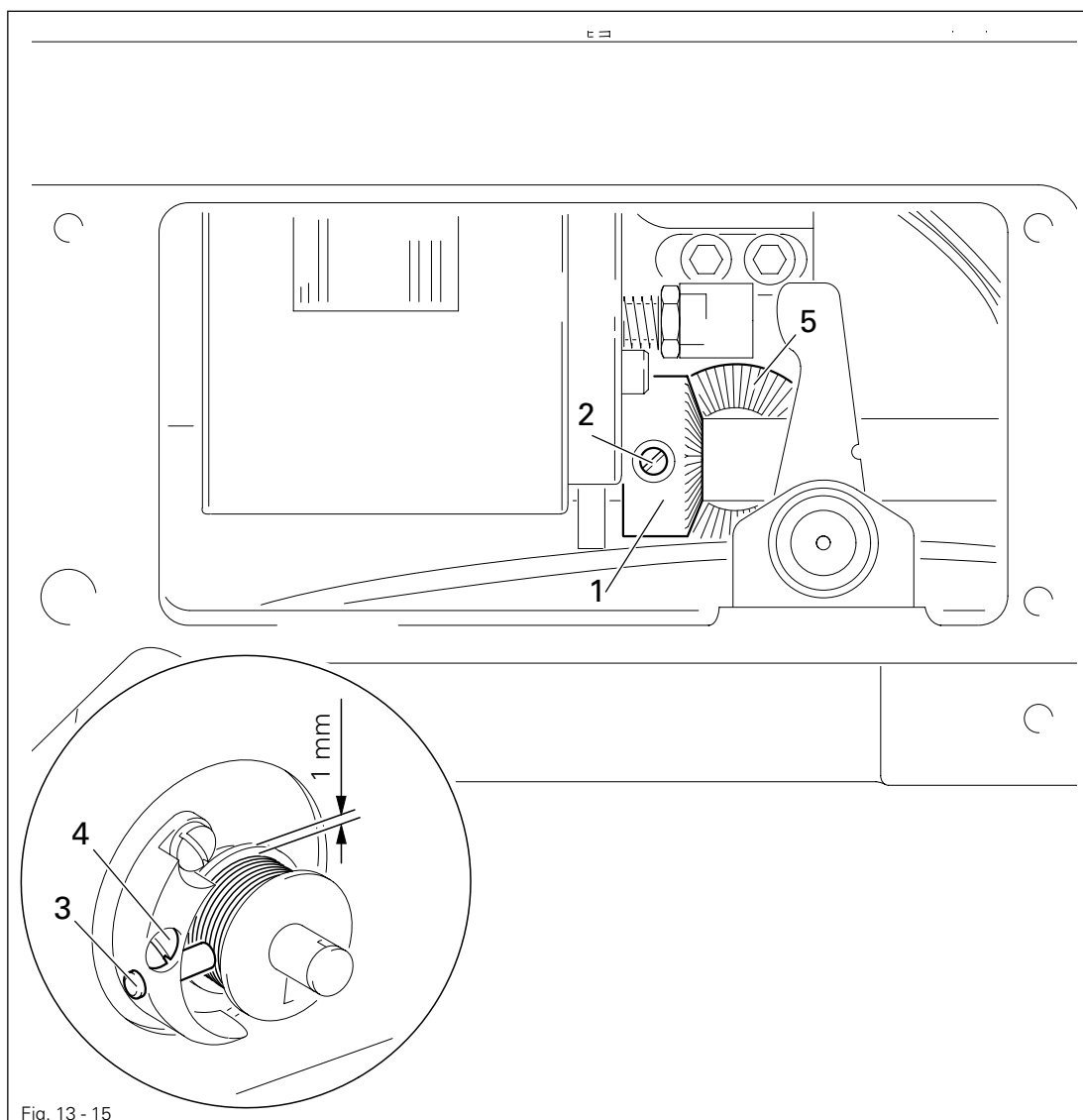
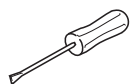

Fig. 13 - 15



- Move drive wheel **1** (screws **2**) in accordance with **requirement 1**.
- Move pin **3** (screw **4**) in accordance with **requirement 2**.

13.04.18 Roller presser pressure

Requirement

The material must be fed reliably. There must not be any pressure marks on the material.



On the 3834-4/21 the maximum pressure is 25N.

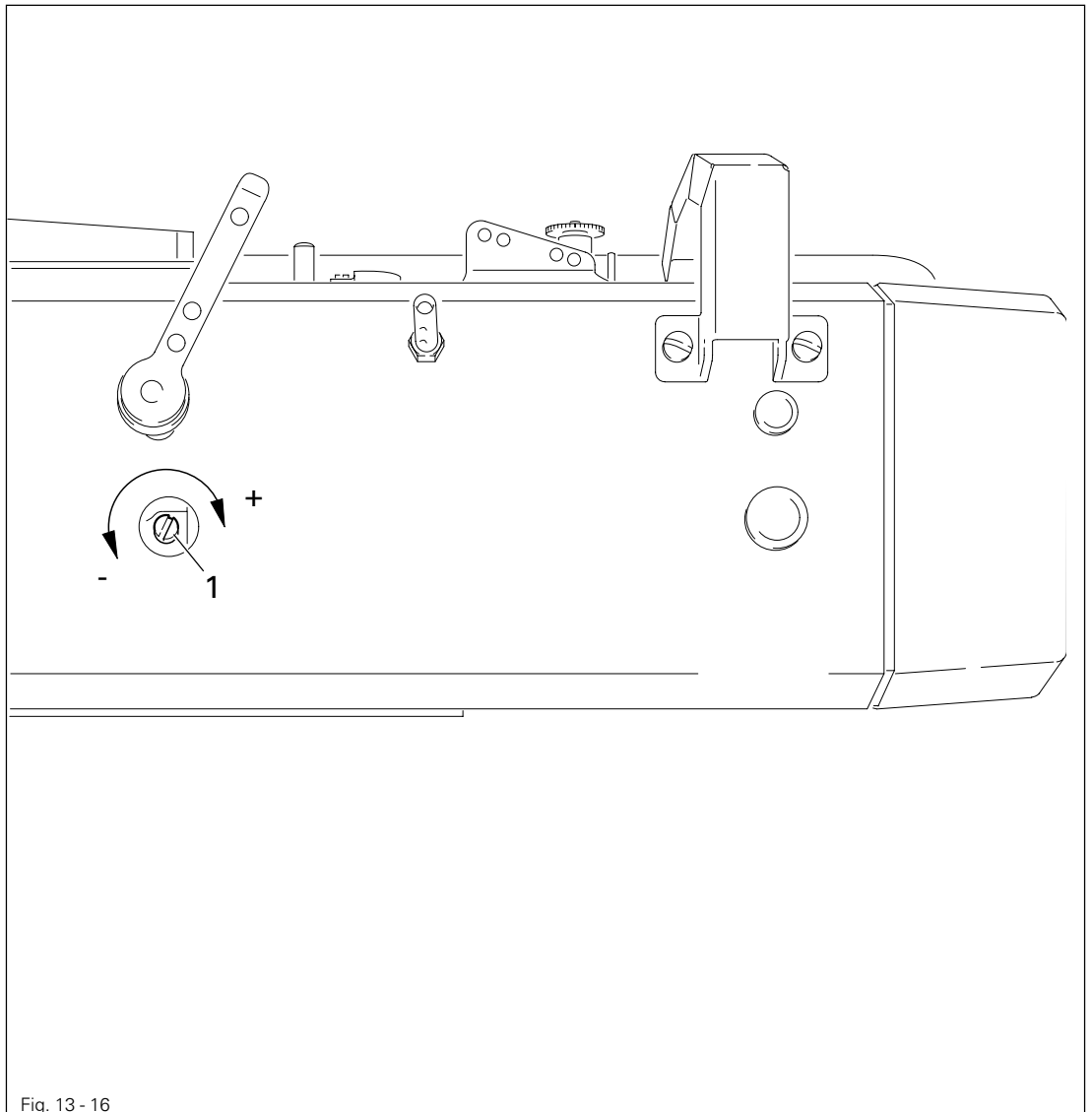
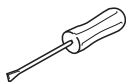

Fig. 13 - 16



- Adjust the roller presser pressure with screw 1 according to the **requirement**.



Screw 1 is underneath a cover.



When the roller presser pressure is low, the lowering speed of the roller presser can be increased by switching on the function ROLLER PRESSER DE-ENERGIZER. See chapter 11.05 Summary of the functions in INPUT mode

Adjustment

13.05 Adjusting the thread trimmer -900/53

13.05.01 Removing the scissors

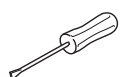
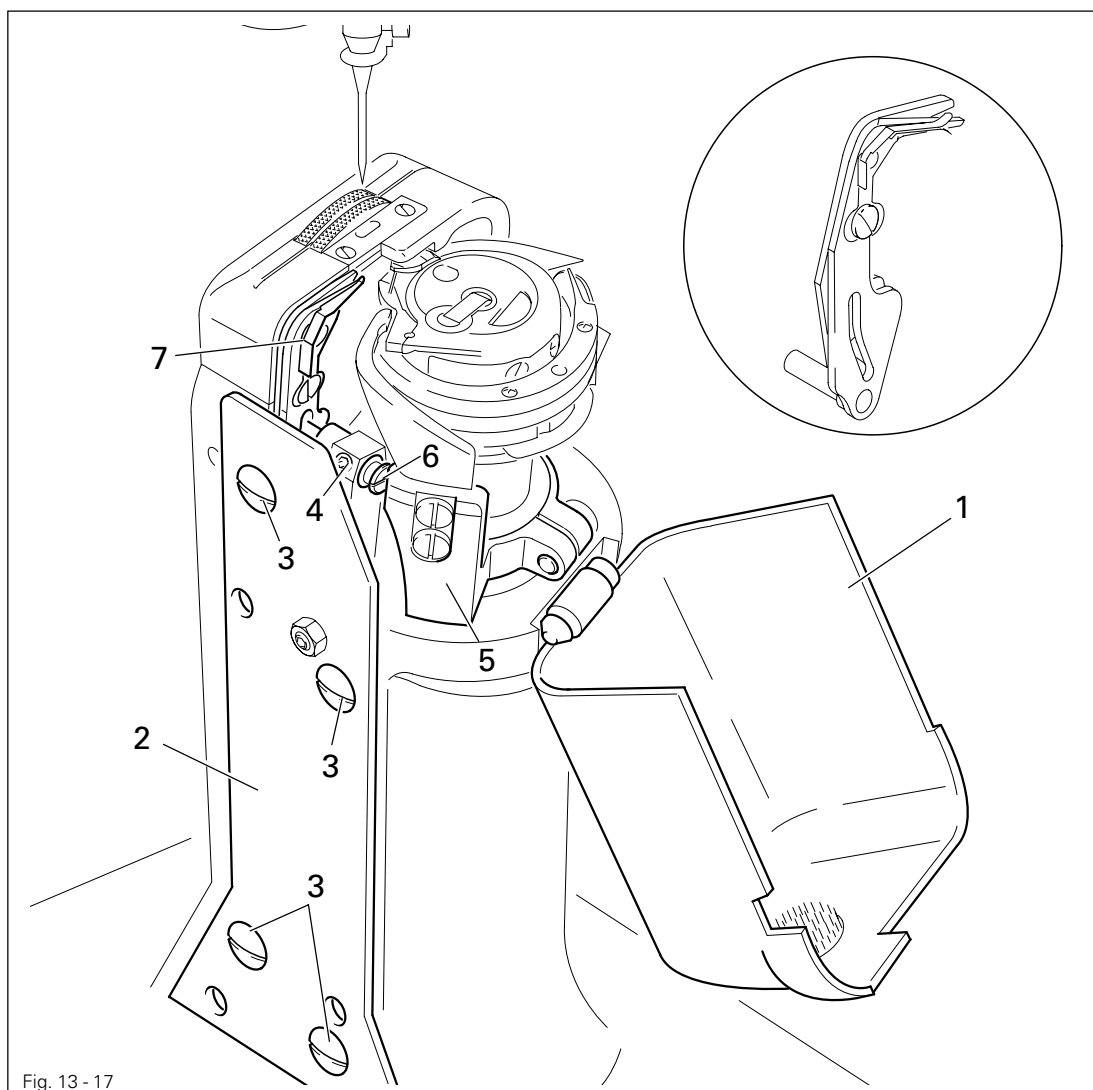

- Open post cover 1 and unscrew post cover plate 2 (screws 3).
- Loosen screw 4.
- Swing out bobbin case base 5 by hand and hold it in this position.
- Remove bolt 6.
- Open the scissor drive bar and remove scissor 7.
- Allow bobbin case base 5 to swing in and close the scissor drive bar.



Post cover plate 2 remains dismounted for further adjustments.

13.05.02 Control cam to bobbin opener and tripping lever

Requirement

1. Control cam 2 must be touching bearing collar 3.
2. The roller of tripping lever 6 must fall slightly into the path of control cam 2.

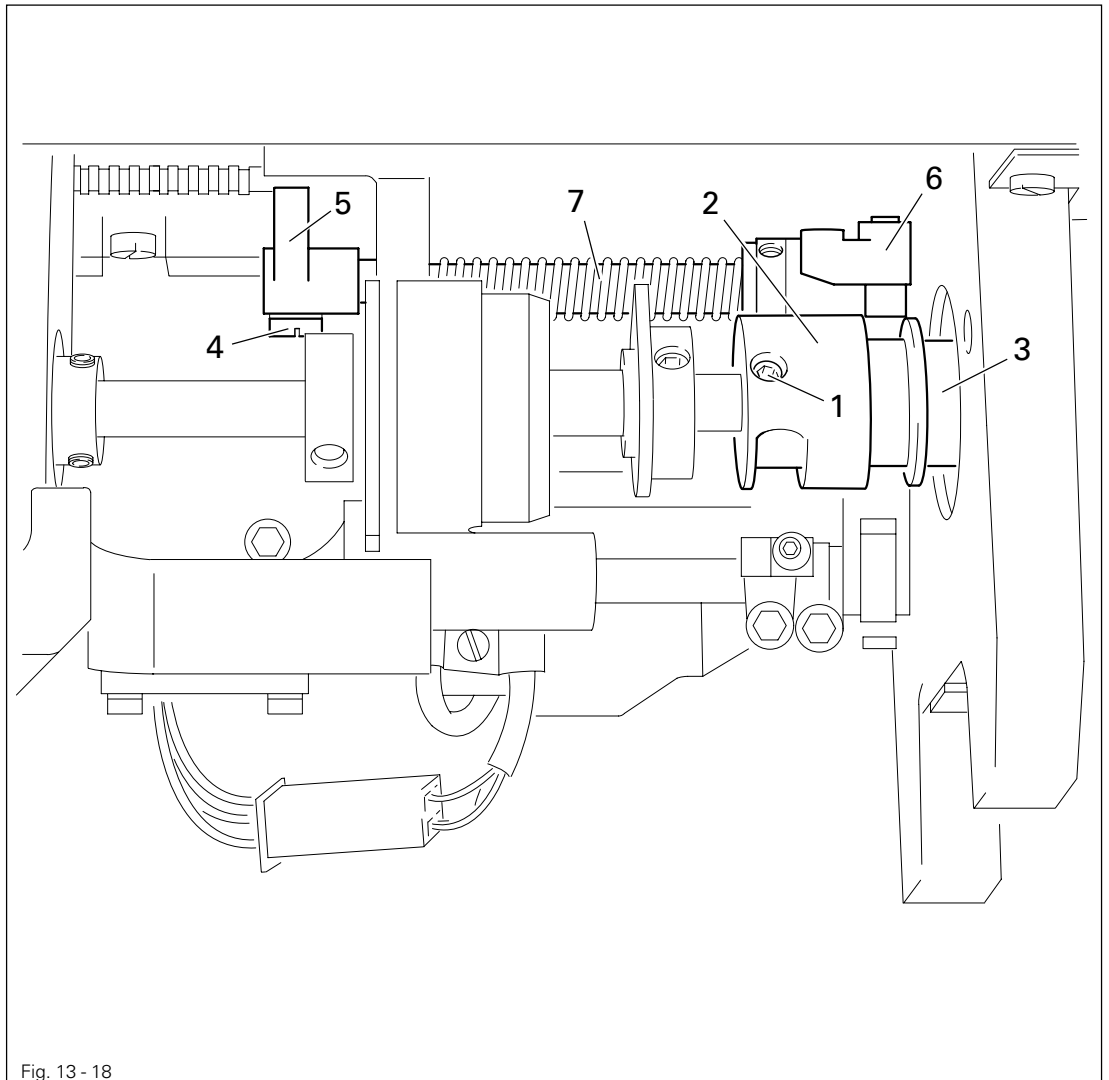
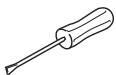

Fig. 13 - 18



- Loosen screws 1 and bring control cam 2 to rest against bearing collar 3.
- In this position tighten one of the screws 1 slightly so that control cam 2 can still be turned.
- Loosen screw 4.
- Bring the needle bar to BDC and position the straight section of the cam track under the roller of tripping lever 6.
- Activate the engaging lever by hand.
- Move tripping lever 6 together with shaft 7 in accordance with **requirement 2**.
- Taking care to ensure that connecting link 5 engages completely in the groove of the rack, bring connecting link 5 to rest on the right and tighten screw 4.



Tighten screws 1 only slightly for the following adjustment.

Adjustment

13.05.03 Radial position of the tripping lever

Requirement

With the tripping lever **3** in resting position, there must be a clearance of **0.3 mm** between its roller and the circumference of the control cam **4**.

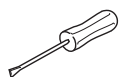
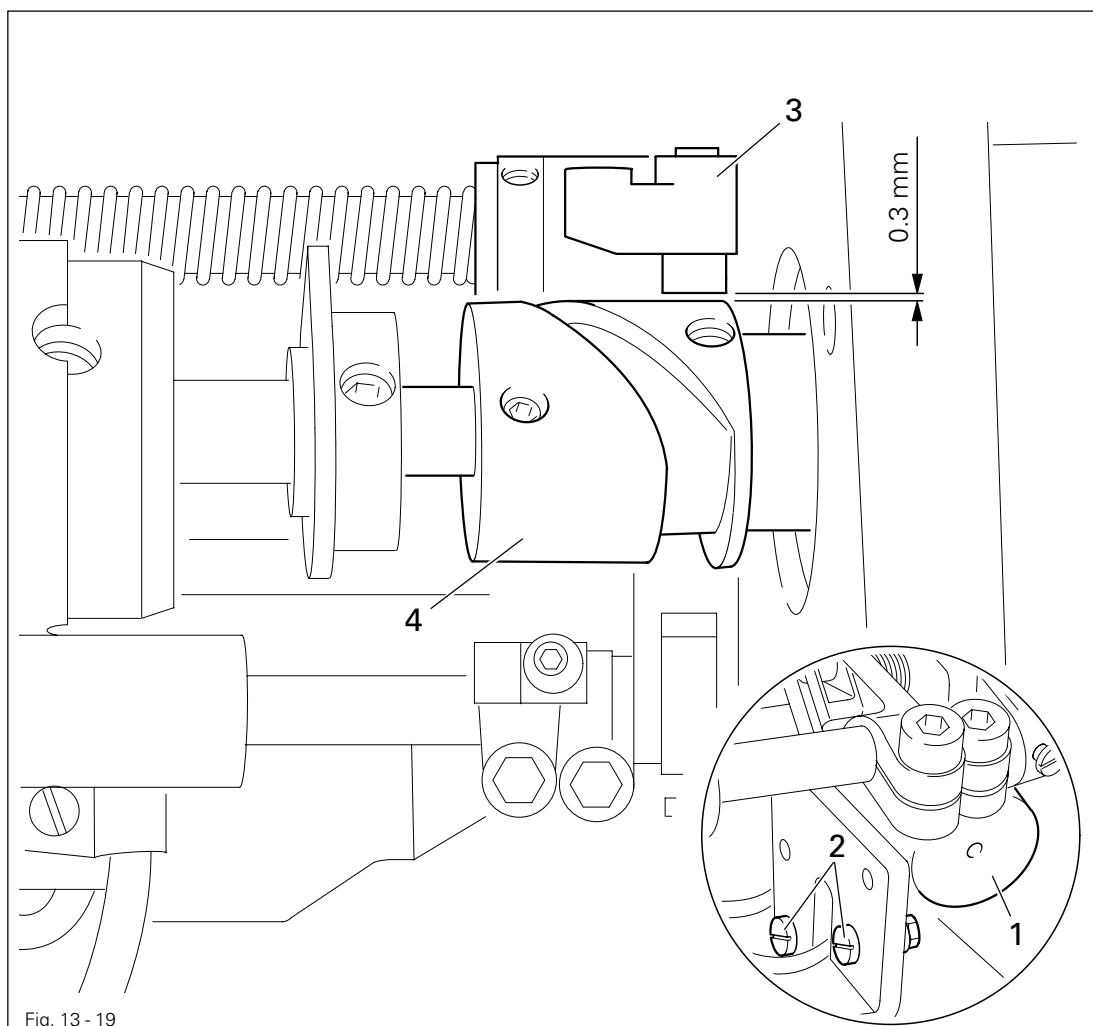

- Bring the needle bar to BDC.
- Move solenoid carrier **1** (nuts of screws **2**) in accordance with the **requirement**.

13.05.04 Engaging solenoid

Requirement

With the trimming device switched on, the field core must be positioned **1 mm** before its lower stop.

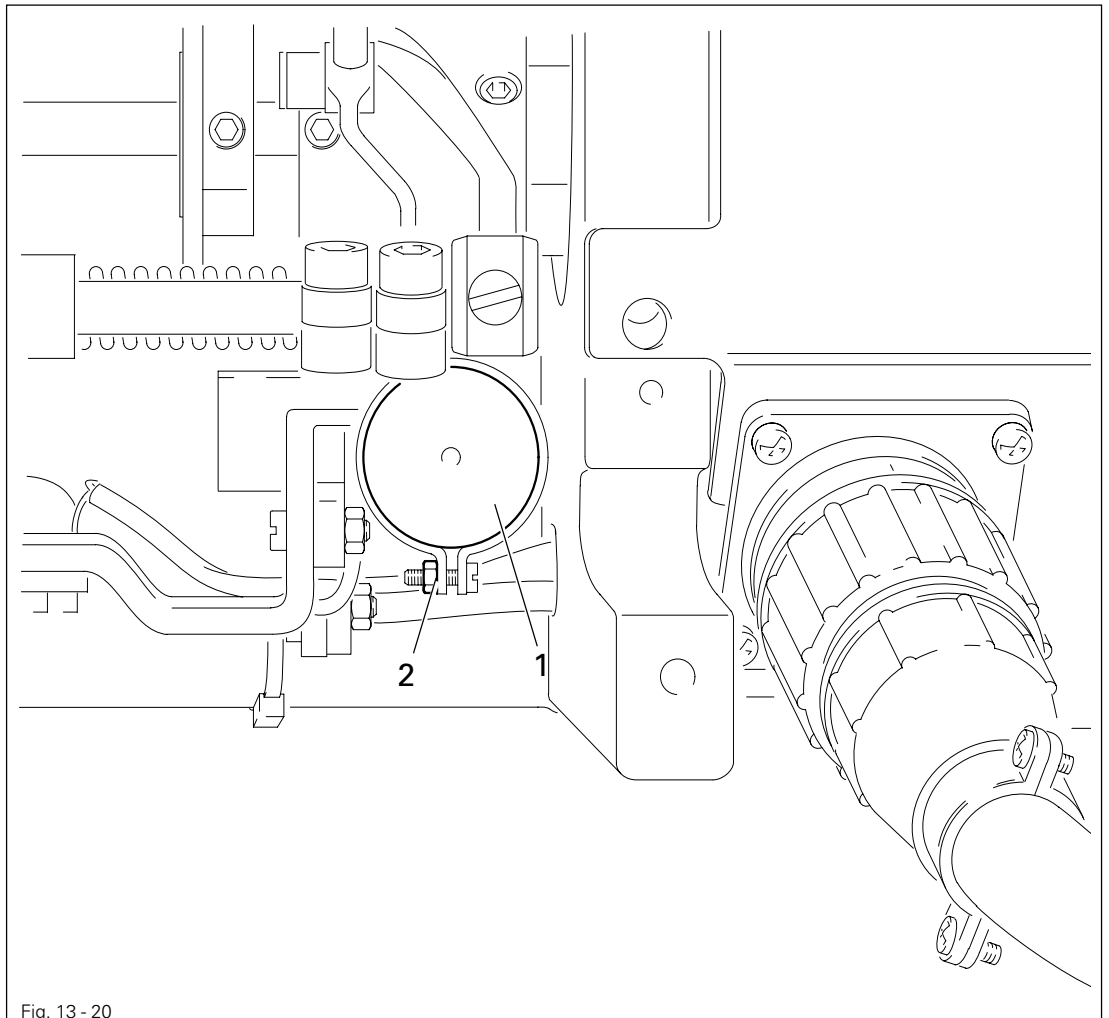
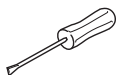

Fig. 13 - 20



- Bring the needle bar to BDC and activate the tripping lever by hand.
- Push solenoid housing **1** (screw **2**) up as far as possible and then move it in accordance with the **requirement**.
- Lift the tripping lever out of the control cam by hand.

Adjustment

13.05.05 Scissor drive lever

Requirement

The top edge of screw 1 must protrude approx. **9 mm** from the recess on the housing.

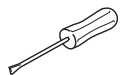
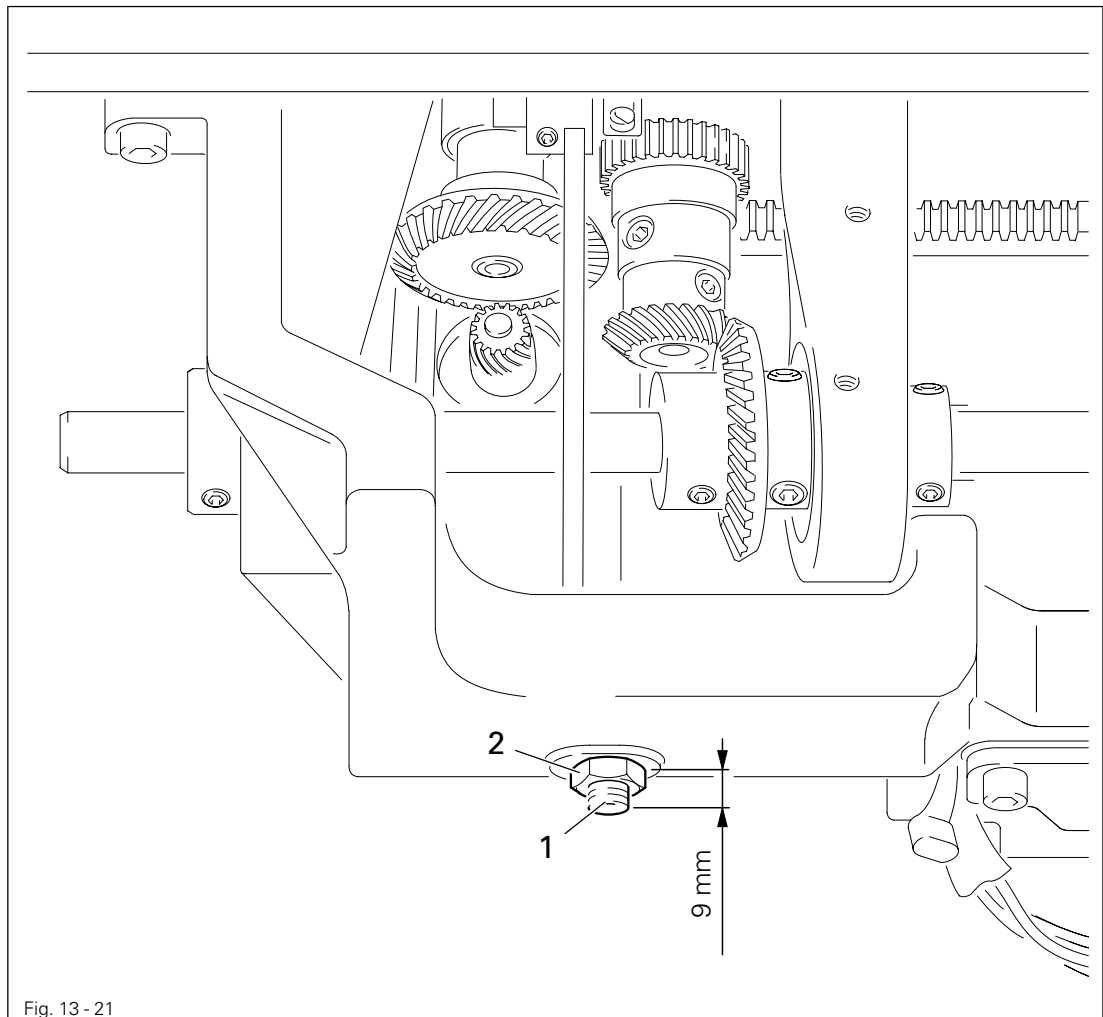

- Turn screw 1 (nut 2) in accordance with the **requirement**.

13.05.06 Adjusting the control cam with the adjustment gauge in relation to the bobbin opener and the scissor

Requirement

With the needle bar at BDC, both control cams must be positioned in such a way that

1. adjustment gauge 5 can be slid into the grooves of both control cams,
2. both cams are on the rests of adjustment gauge 5 and
3. the bent section of adjustment gauge 5 is touching roller 3.

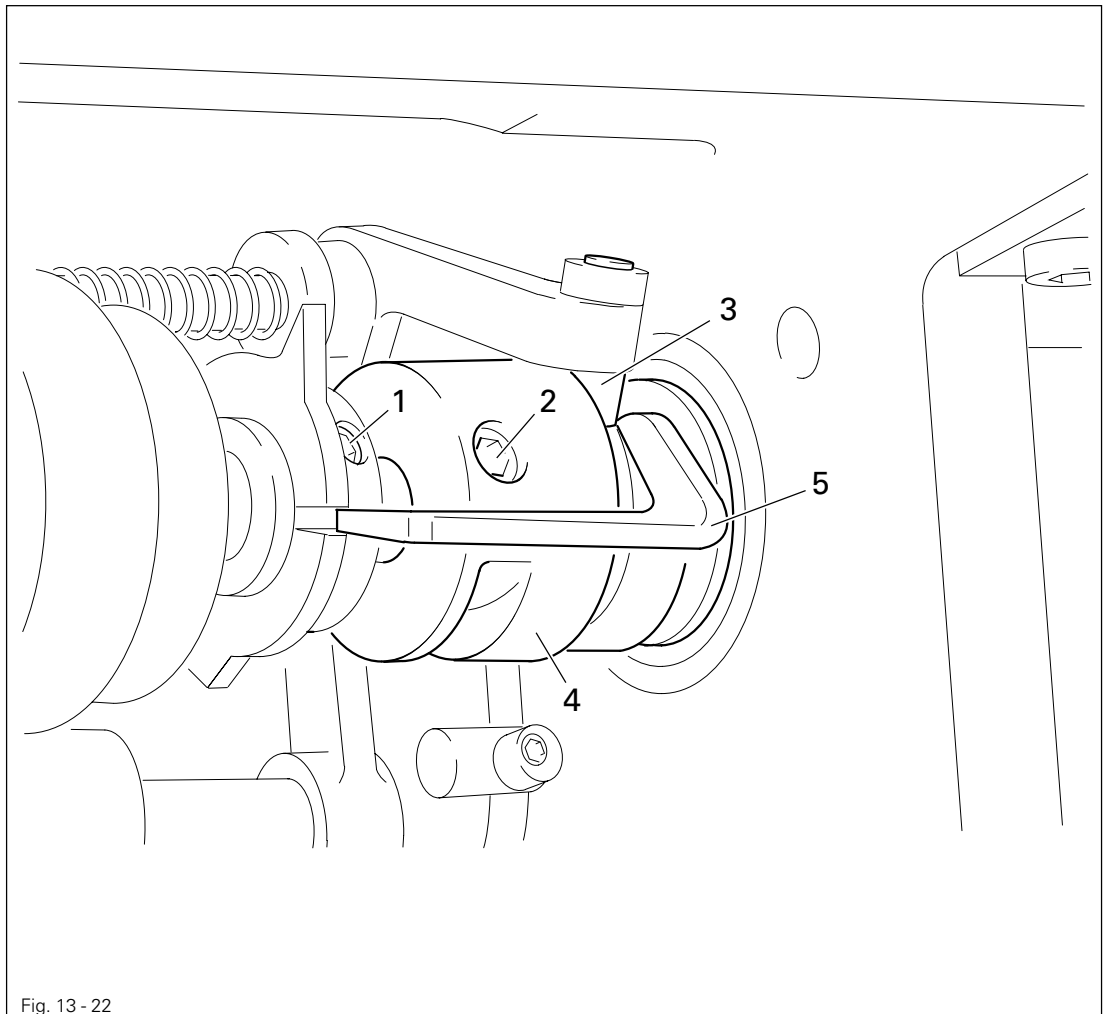
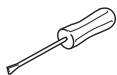

Fig. 13 - 22



- Loosen screws 1 and 2.
- Bring the needle bar to BDC and activate the tripping lever by hand (roller 3 engaged).
- Adjust the control cams in accordance with the **requirement** and insert adjustment gauge 5.
- Turn control curve 4 in accordance with the **requirement**.
- Taking care to ensure that control cam 4 is touching the bearing collar, tighten the accessible screws 1 and 2.
- Remove adjustment gauge 5 and tighten the remaining screws 1 and 2.



For adjustment without the gauge see chapter 13.05.07 Radial position of the control cam in relation to the bobbin opener and chapter 13.05.09 Control cam in relation to scissor.

Adjustment

13.05.07 Radial position of the control cam in relation to the bobbin opener

Requirement

The retracting motion of the bobbin opener must begin when the needle bar is 4 mm after BDC.

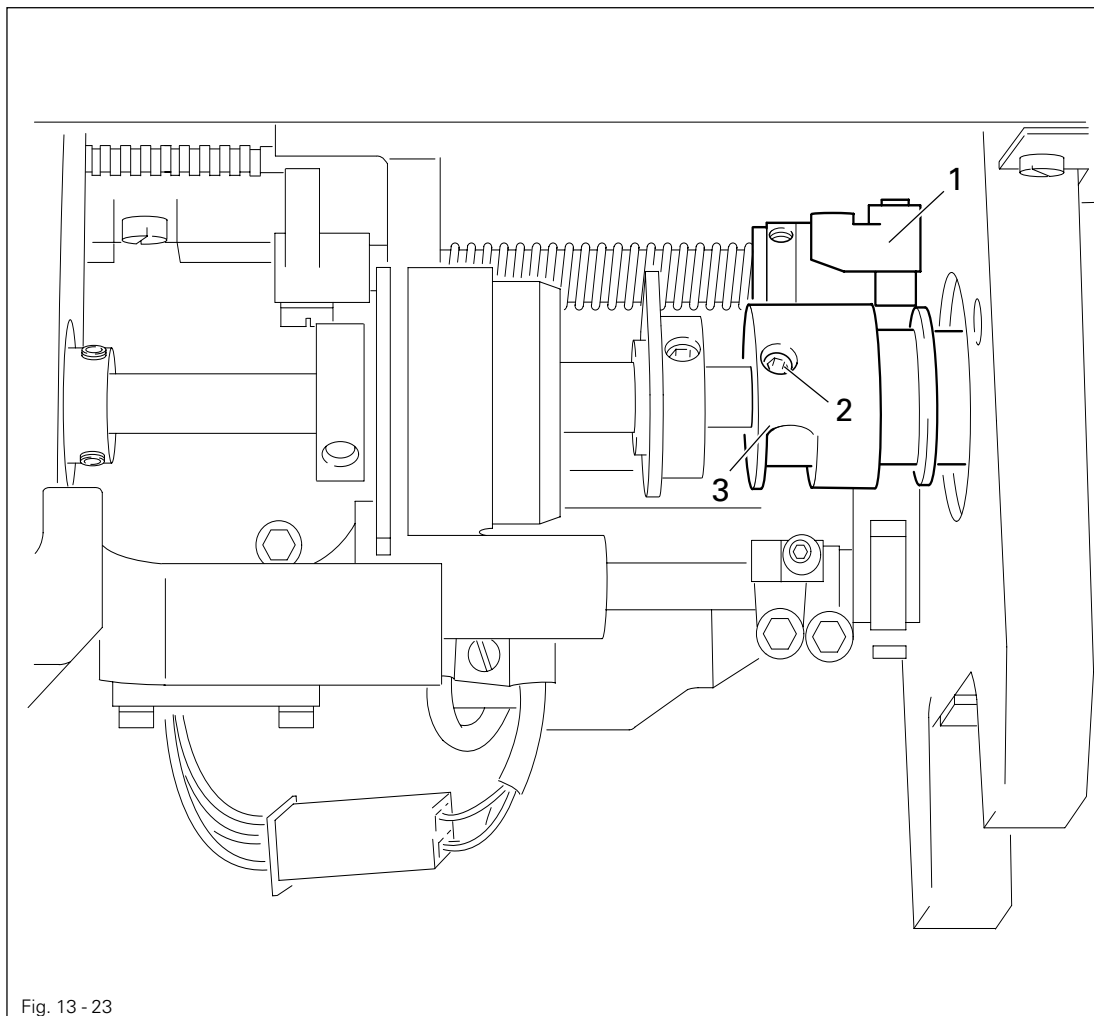
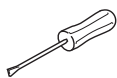

Fig. 13 - 23



- Activate the tripping lever by hand. The roller of the tripping lever 1 must engage easily and without obstruction in the cam track.
- Bring the needle bar to 4 mm after BDC (use adjustment gauge and C-clamp).
- Turn control cam 3 in the direction of rotation until you feel resistance (start of the retracting motion).
- In this position tighten the accessible screw 2.
- Remove tripping lever 1 out of the control cam 3 by hand.
- Remove the C-clamp and tighten the remaining screws 2.

13.05.08 Scissor tripping-lever in relation to the control cam of the scissor

Requirement

At the left point of reversal of the rock shaft 3

1. the roller of tripping lever 4 and the roller of return lever 5 must be in the middle of control cam 6 and
2. there must be a distance of 0.3 mm between the roller of tripping lever 4 and the external circumference of control cam 6.

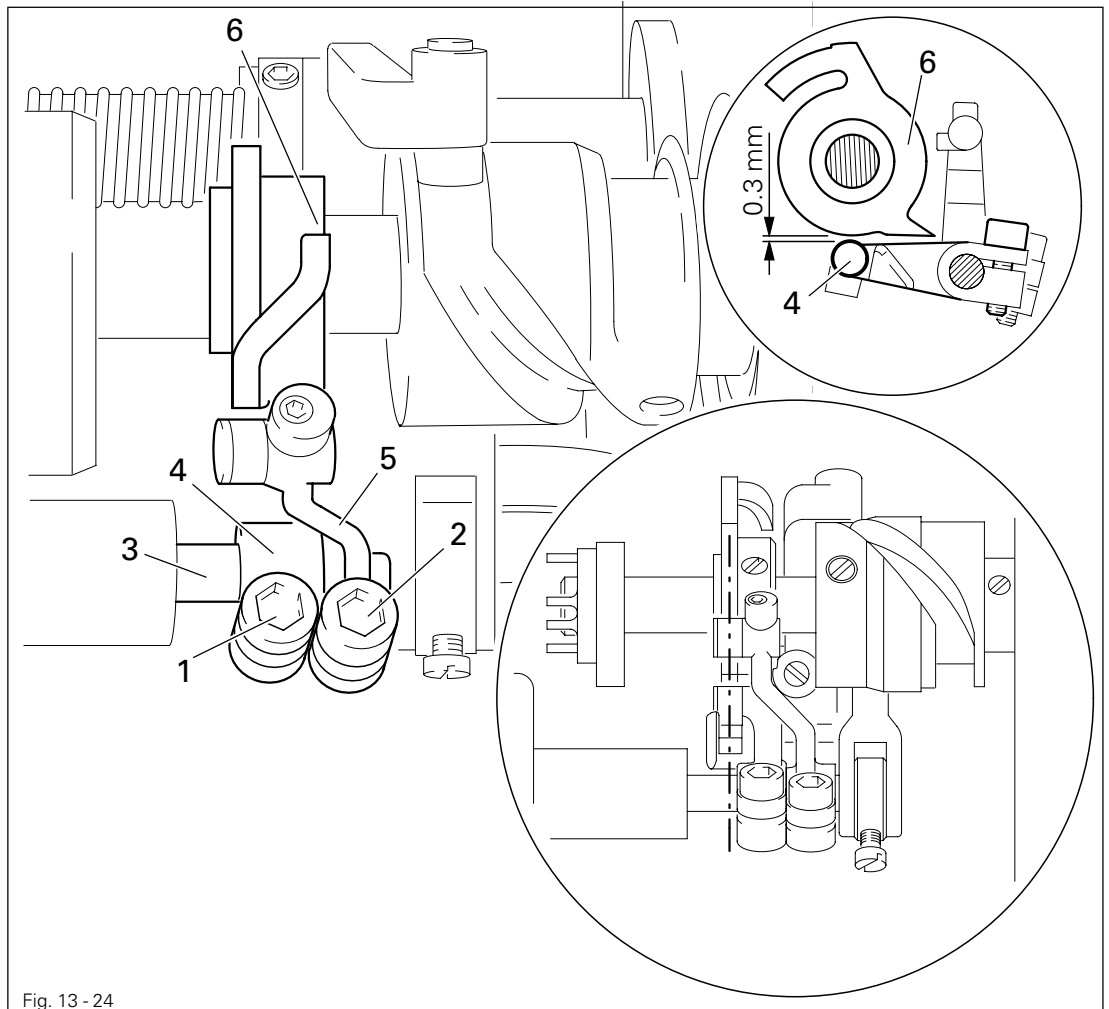
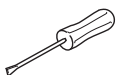

Fig. 13 - 24



- Bring the needle bar to BDC and activate the tripping lever by hand.
- Loosen screws 1 and 2.
- Turn the handwheel in the direction of rotation until rock shaft 3 is at its left point of reversal.
- Move tripping lever 4 and return lever 5 in accordance with **requirement 1**.
- Turn tripping lever 4 in accordance with **requirement 2**.
- In this position and observing **requirement 1**, tighten screw 1.



Screw 2 remains loosened for the following adjustment.

13.05.09 Control cam in relation to scissor

Requirement

1. The cutting motion must begin when the needle bar is positioned at 0.6 mm after TDC.
2. There must be a clearance of 9 mm between control cams 2 and 4.

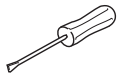
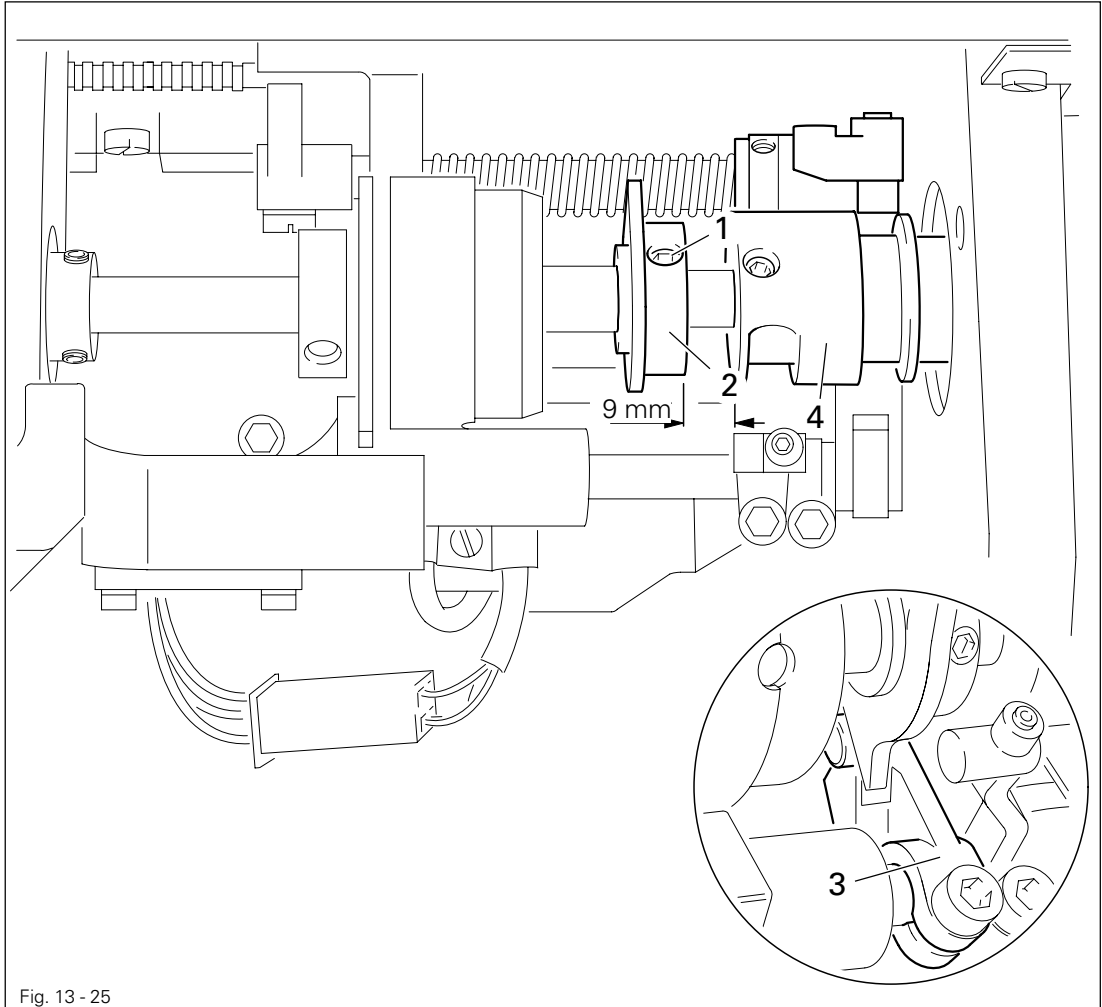

- Loosen screws 1.
- Bring the needle bar to BDC and activate the engaging lever by hand.
- Bring the needle bar to 0.6 mm after TDC (use adjustment gauge and C-clamp).
- Turn control cam 2 until the trip is touching the roller of the tripping lever 3.
- Taking care that control cam 2 is 9 mm from retractor cam 4, tighten one of the screws 1.
- Remove the C-clamp, make the second screw 1 accessible and tighten it.



When using elastic sewing threads it may be necessary to set the relationship between the control cam and the bobbin opener and the scissors somewhat "later".

A thread tension control (subclass 906/10) is available for automatic tension-release when highly elastic sewing threads are used.

13.05.10 Scissor return lever

Requirement

When the roller of tripping lever **3** is exactly at the point of the trip of control cam **2** the maximum distance between the roller of return lever **4** and control cam **2** must be **0.2 mm**.

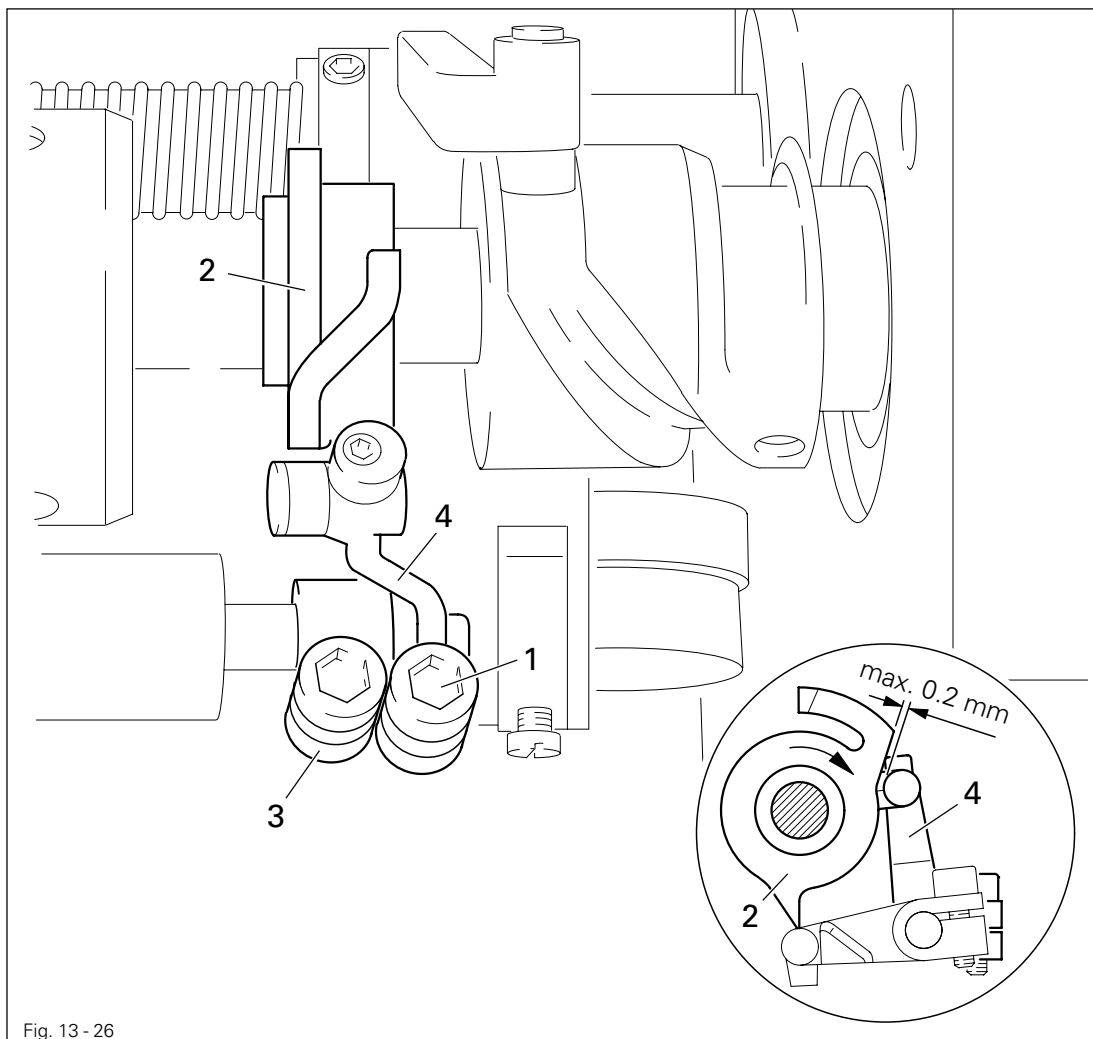
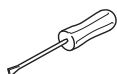

Fig. 13 - 26



- Loosen screw 1.
- Bring the needle bar to BDC and activate the engaging lever by hand.
- Position the point of the trip of control cam **2** exactly at the middle of the roller of tripping lever **3** by turning the handwheel in the direction of sewing.
- Maintaining this position, bring the return lever **4** to rest against the side of tripping lever **3** and turn it radially in accordance with the **requirement**.
- Tighten screw 1.

13.05.11 Scissor return control

Requirements

1. When the point of the trip of control cam 1 is exactly at the roller of tripping lever 2 and trip 3 is touching the beginning of the angular edge of guide plate 5 (see arrow) there must be a clearance of approx. **0.6 mm** between trip 3 and guide plate 5.
2. When the rock shaft has sprung back to its starting position the maximum clearance between trip 3 and guide plate 5 must be **0.3 mm**.

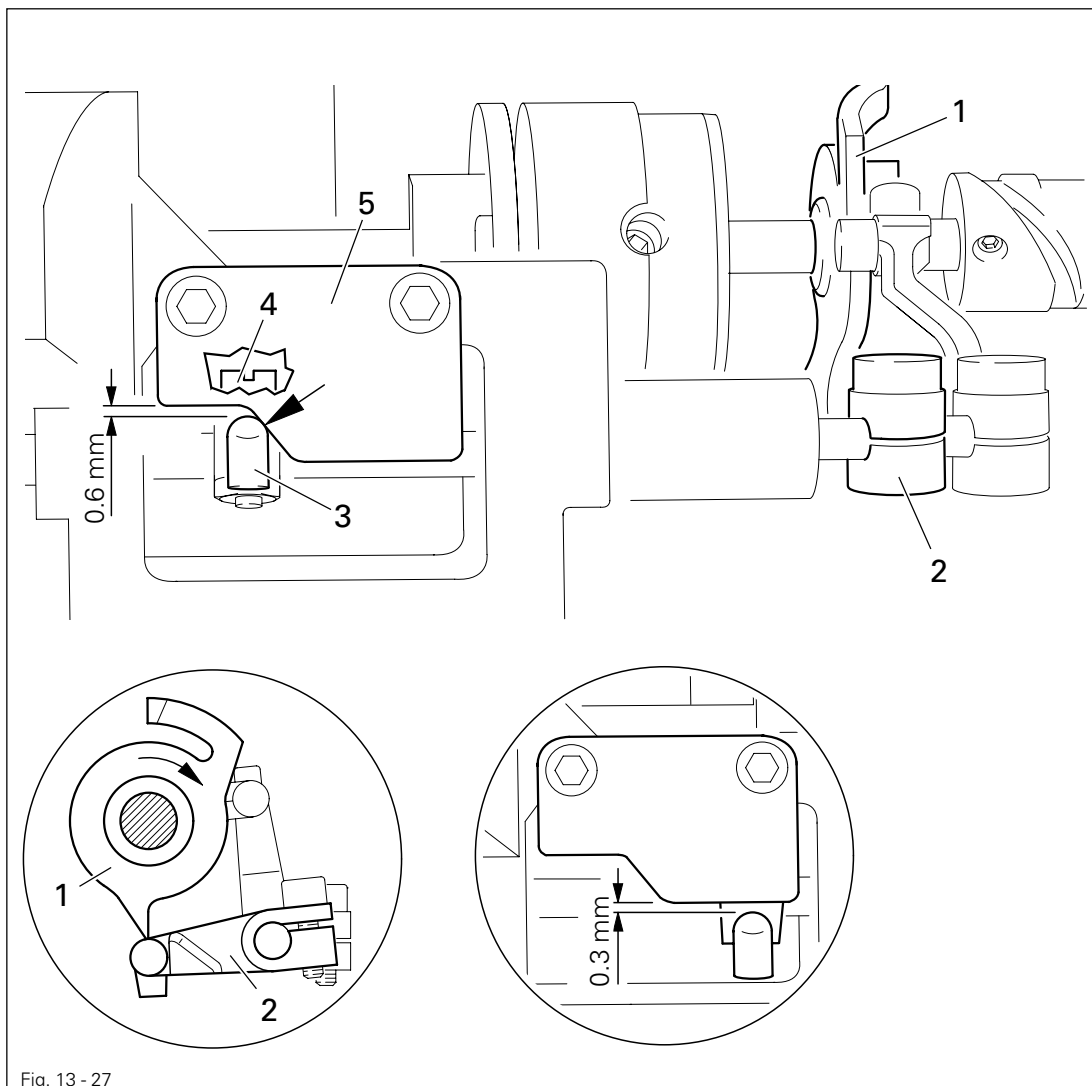
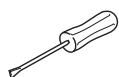

Fig. 13 - 27



- Position the point of the trip of control cam 1 exactly at the roller of tripping lever 2 by turning the handwheel.
- Move trip 3 (screw 4) in accordance with **requirement 1**.
- Bring rock shaft back to its starting position.
- Check **requirement 2**. If necessary, position guide plate 5 appropriately.

13.05.12 Installing the scissor

Requirements

1. The pin of bolt 4 must protrude into the cam tracks of the scissor halves.
2. The scissor must work with as little lateral play as possible.

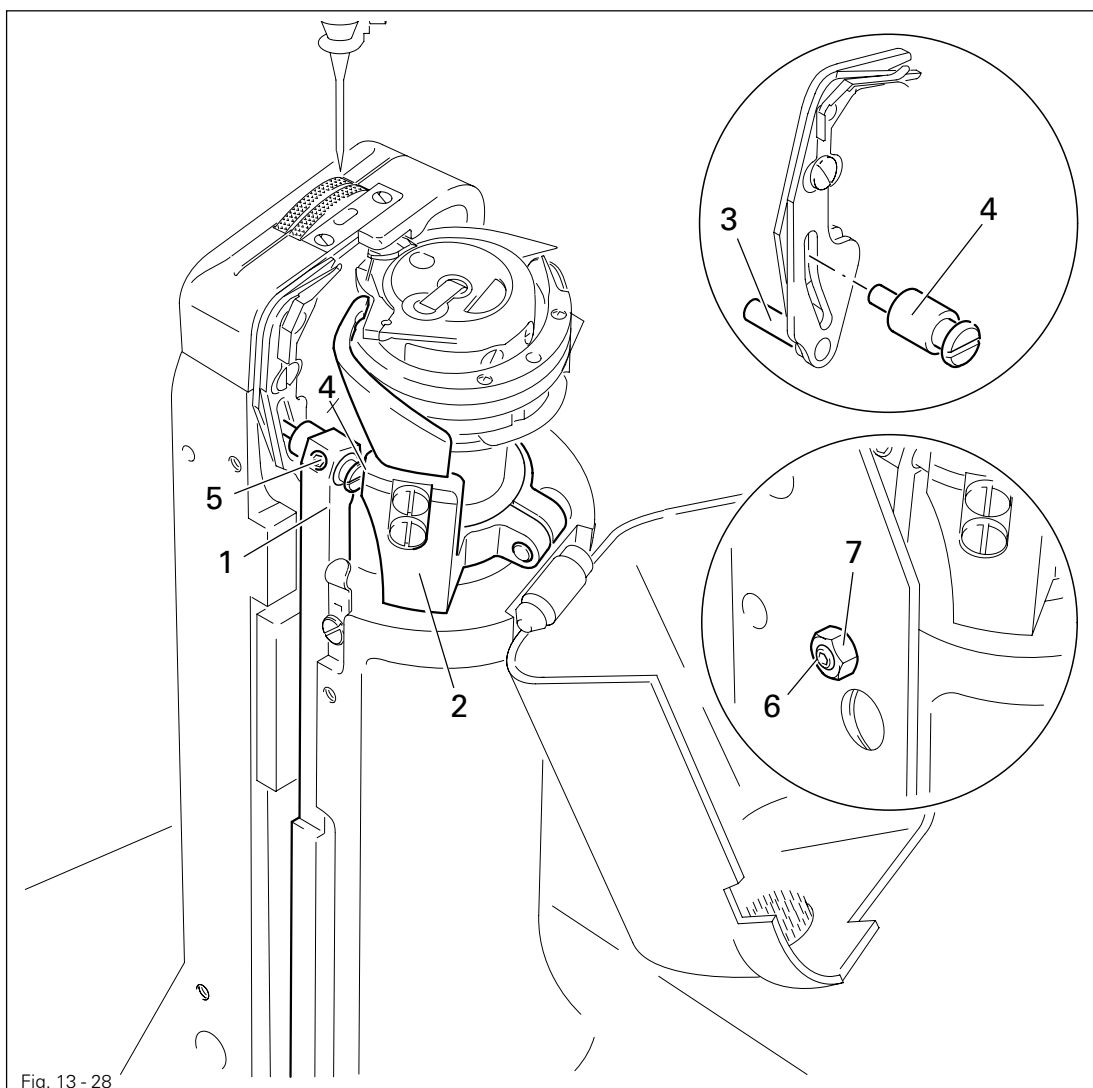
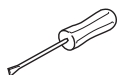

Fig. 13 - 28



- Swing out drive bar 1.
- Swing out bobbin opener 2 by hand and hold it.
- Insert the scissor with its bearing pin 3 into the bearing bushing of the feed wheel post.
- Swing in drive bar 1 and insert pin 4 in accordance with **requirement 1**.
- Position the eccentricity of pin 4 so that it faces upwards.
- Tighten screw 5 and screw on the post cover plate.
- Check drive bar 1 for free movement and friction-free running. If necessary, adjust with screw 6 (nut 7).

13.05.13 Eccentric sleeve

Requirements

1. In its starting position the scissor must be flush with the contour of the needle plate.
2. The scissor must lightly touch the needle plate and the eccentric sleeve 2.

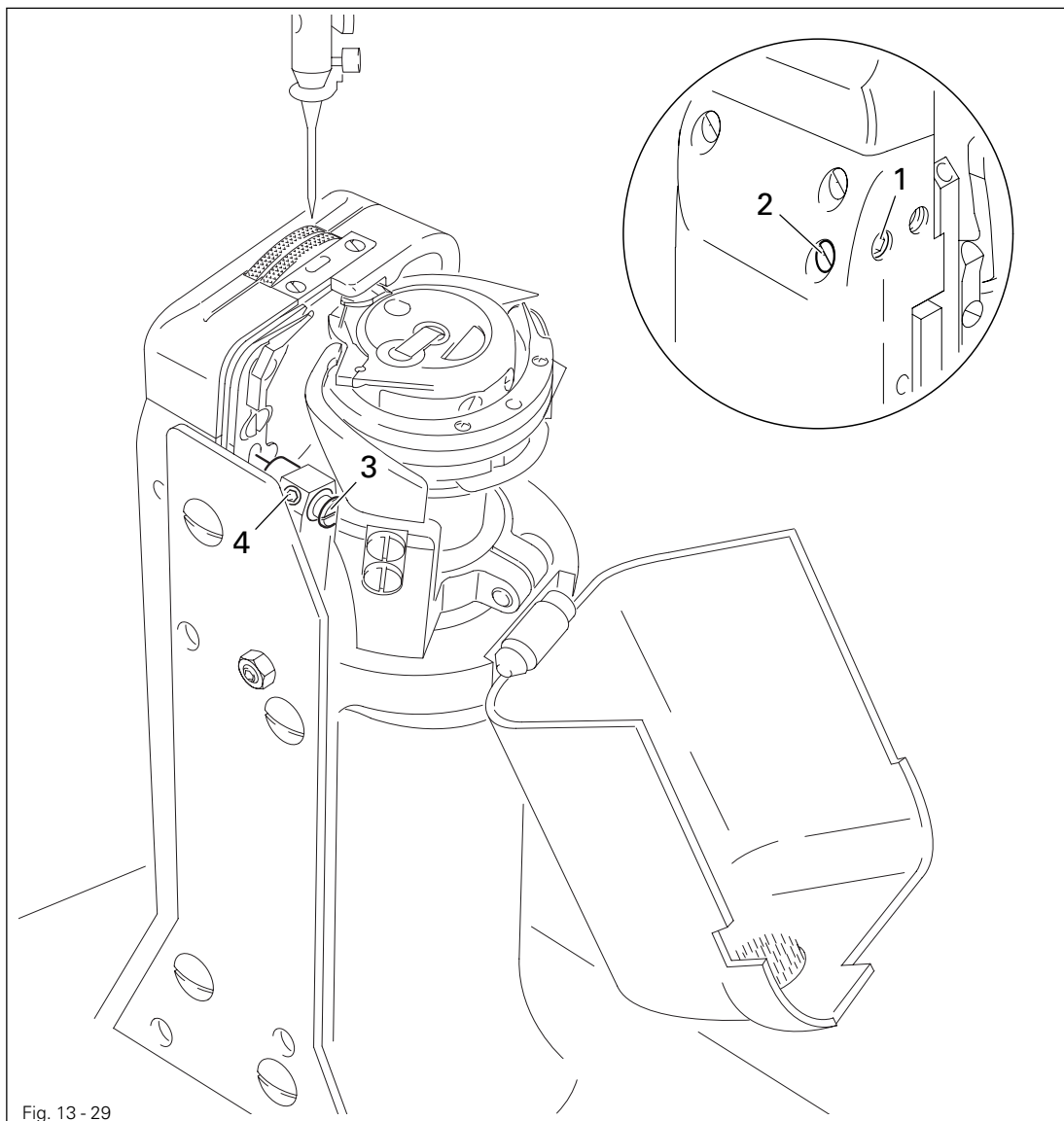
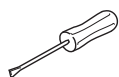

Fig. 13 - 29



- Loosen screw 1 enough so that eccentric sleeve 2 can still be turned.
- Turn eccentric sleeve 2 until the scissor is flush with the needle plate.
- While maintaining this position, move eccentric sleeve 2 laterally in accordance with the **requirement**.
- Tighten screw 1.
- Press pin 3 (screw 4) lightly against the scissor.

13.05.14 Scissor drive bar

Requirements

1. In its starting position the scissor must be flush with the needle plate contour.
2. At the TDC of the drive bar **2** there must be a safety clearance of at least **0.3 mm** between pin **4** and the top end of the cam guide.

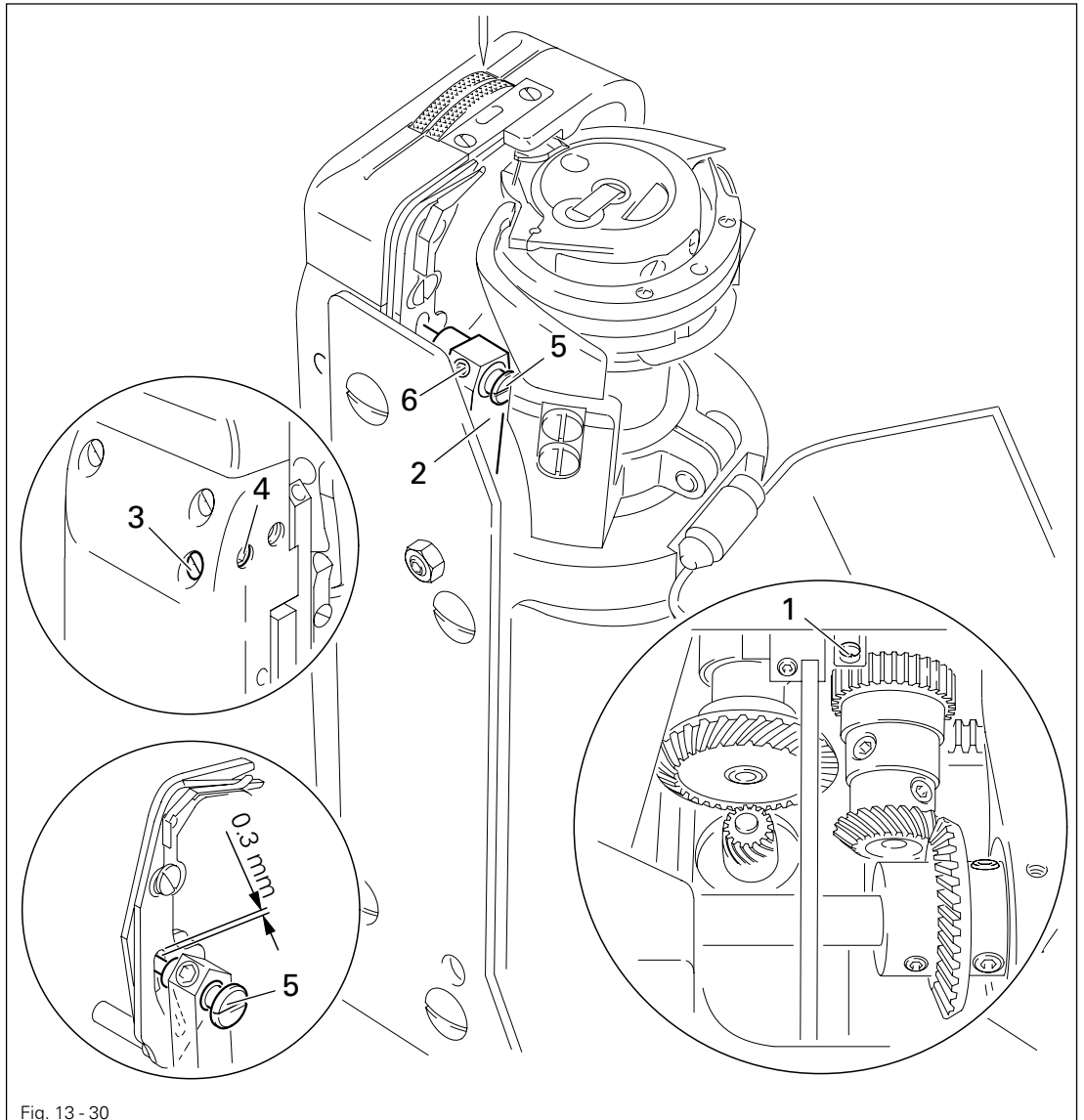
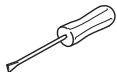

Fig. 13 - 30



- Bring the needle bar to BDC and activate the engaging lever by hand.
- Bring drive bar **2** to its top point of reversal by turning the handwheel.
- Carry out the alteration on the drive bar **2** (screw **1**), the eccentric sleeve **3** (screw **4**) and/or the eccentric pin **5** (screw **6**) in accordance with the **requirement**.
- Check the **requirement** from **chapter 13.05.13 Eccentric sleeve**.
- Bring the thread trimmer to its starting position using the handwheel.

13.05.15 Scissor function test

Requirements

1. The threads must be cut neatly.
2. After being trimmed, the bobbin thread must be held securely by the thread trapper.

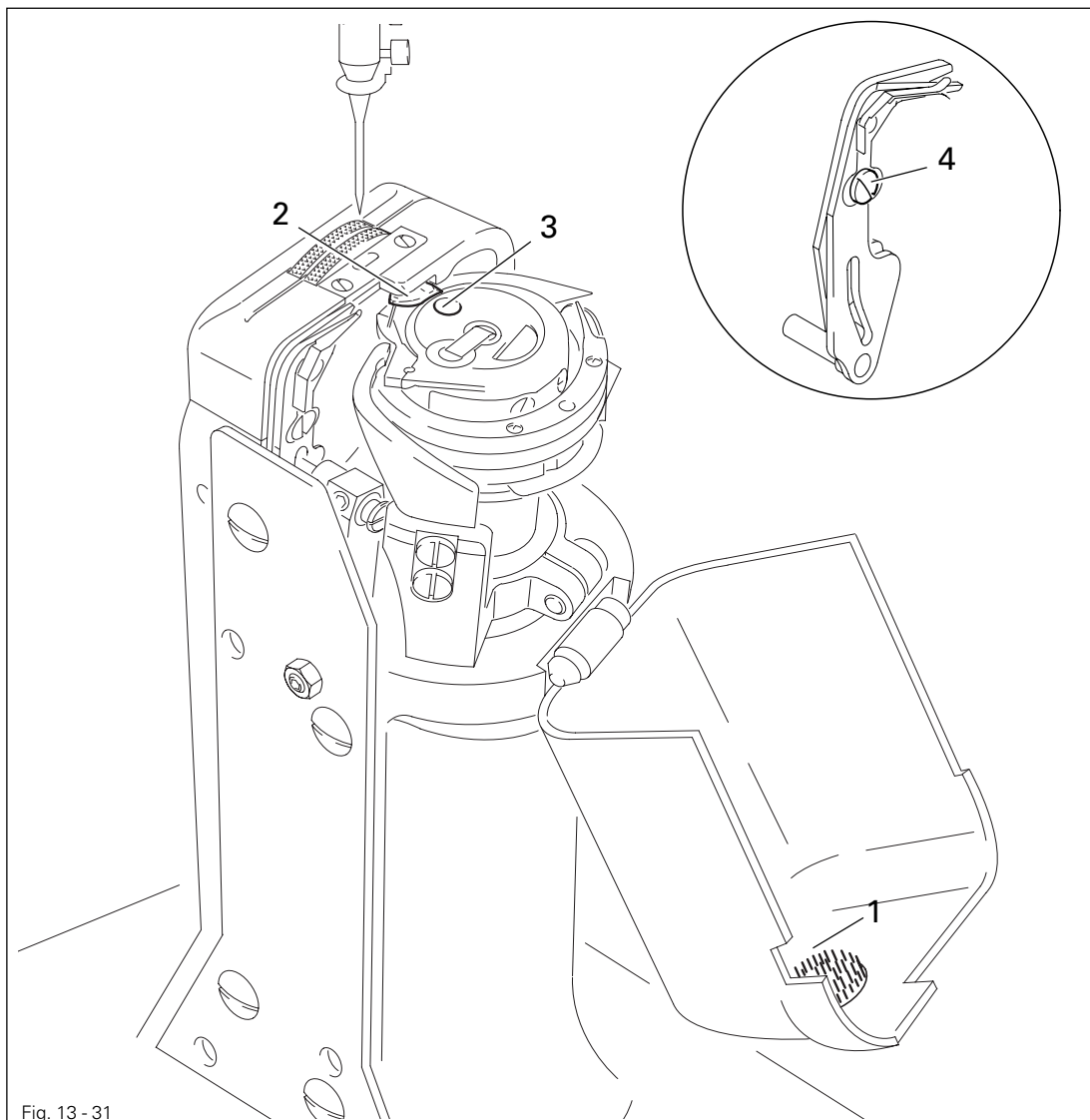
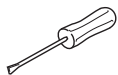

Fig. 13 - 31



- Turn the machine on.
- Sew a few stitches and turn the on/off switch off.
- Activate the engaging lever by hand and close the post cover while ensuring that pressure disk 1 is affixed in the post cap.
- Bring the needle bar to TDC by turning the handwheel and open the post cover.
- In this position the needle and bobbin threads must be held by the catching lug of bobbin case 2 and the needle thread must be held by the catching lug of bobbin 3.
- If the needle thread is not held, affix a new pressure disk 1 (Part no. 91-119 492-91).
- While turning the handwheel, observe the cutting process.

- When the scissor is advancing, the thread trapper must first trap and hold the threads on the scissor (if necessary adjust the thread trapper as required after loosening retaining screw 4).
- As the process continues, both the bobbin thread and the part of the thread loop closest to the scissor which is held by the catching lug must be cut correctly.
- If the threads are not cut or not cut cleanly check **chapter 13.05.14 Scissor drive bar** again.
- Conduct a check according to the **requirement**.

Requirement

When the roller presser is positioned on the material:

1. One source of tension (magnet active) must be active for material thicknesses up to 2 mm.
2. The second source of tension must also be active for material thicknesses of more than 2 mm (magnet not active).

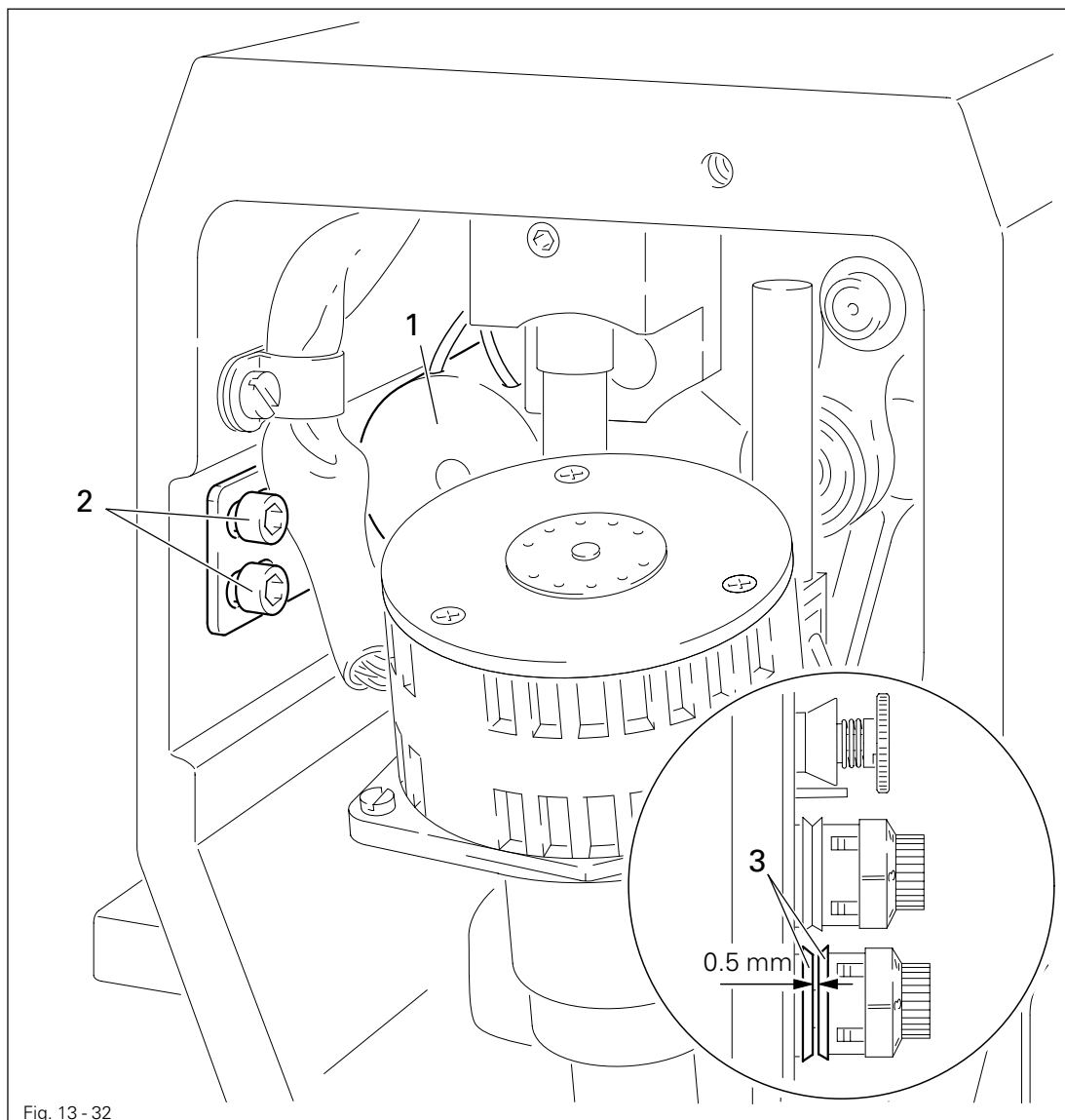
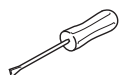

Fig. 13 - 32



- Actuate magnet 1.
- Adjust magnet 1 (screws 2) according to **requirement 1**.
- Adjust switch vane 4 (screw 5) according to **requirement 2**.



This adjustment is a basic setting which can be deviated from depending on the material thickness.

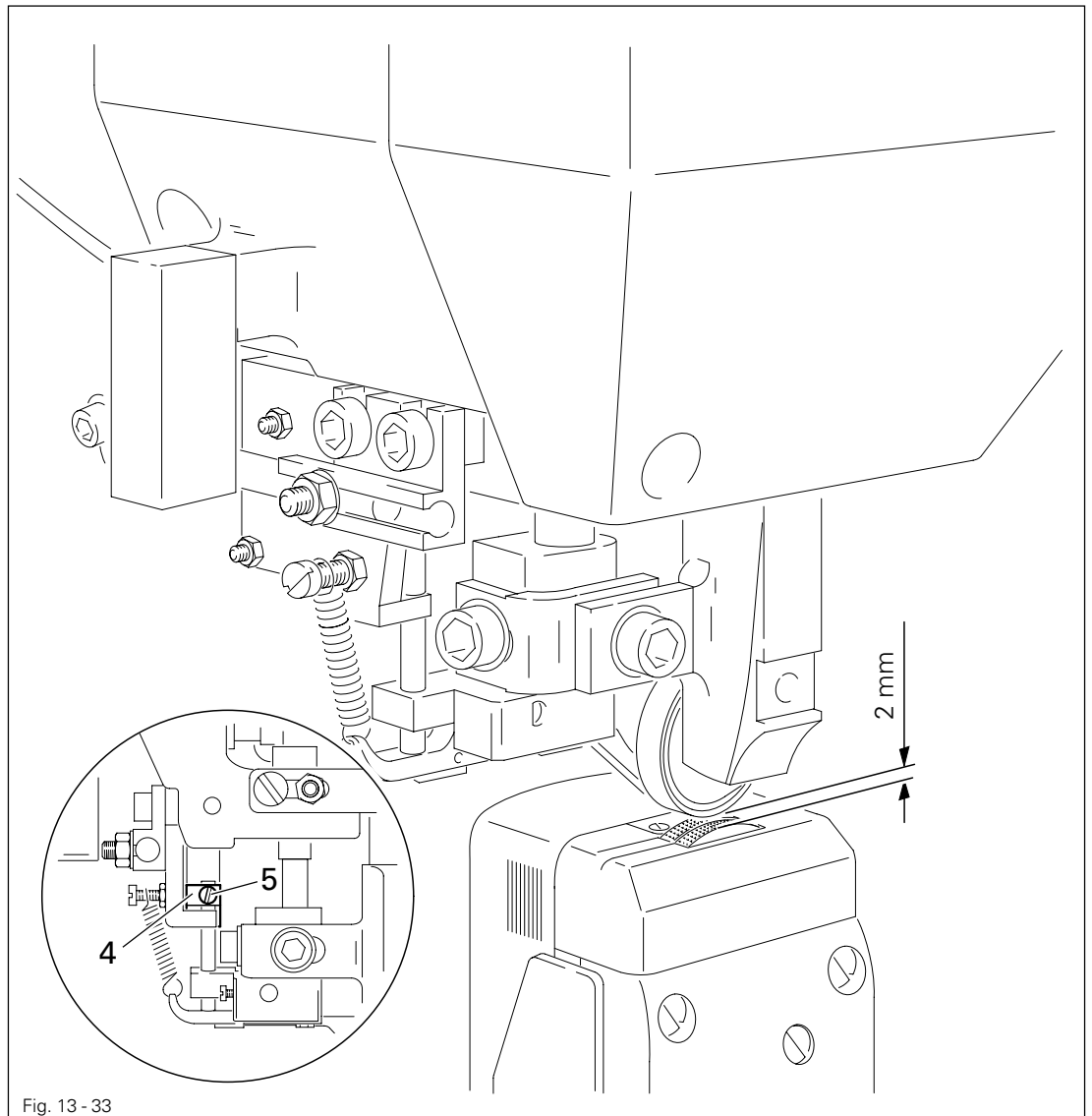

Fig. 13 - 33

13.07 Parameter adjustments

13.07.01 Adjusting positions

- Turn the machine on and sew one stitch.



- Select INPUT mode.



- Select the input menu function (**number key 0**).



- Select the SERVICE function.



- Select the SEWING MOTOR function.



- Select the ADJUST POSITIONS function.

(The current parameter settings are shown in the display.)

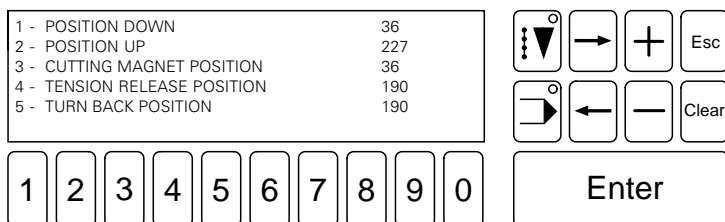

Fig. 13 - 34



The positions shown in **Fig. 13 -34** comply with the standard settings. If these parameter settings are altered, an optimum sewing result cannot be guaranteed.

Adjusting the parameters:



to



- Select the parameter to be altered with the corresponding number key.

- Change the position by turning the handwheel.

Enter

- Confirm the changes made with the **Enter key**.

13.07.02 Adjusting the counter

- Turn the machine on.



- Select INPUT mode.



- Select the input menu function (number key 0).

3

- Select the COUNTER function.

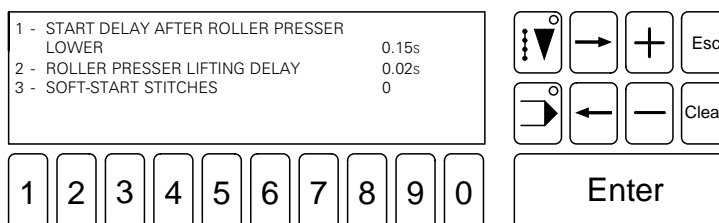

Fig. 13 - 35

Adjusting the parameters:

1 to 3

- Select the parameter to be altered with the corresponding number key.

- Enter the new value via the number keys (observe permissible values).

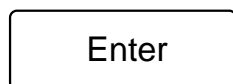

- Confirm the changes with the **Enter** key.

13.08.03 Adjusting speeds

- Turn the machine on.



- Select INPUT mode.



- Select the input menu function (number key 0).

4

- Select the SPEED function.

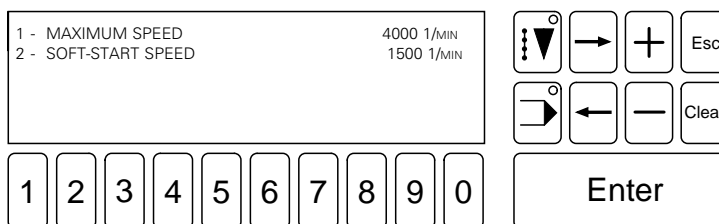

Fig. 13 - 36

- The speeds can be adjusted according to the description found in **13.08.02 Adjusting the counter**.

PFAFF

PFAFF Industrie Maschinen AG

Postfach 3020
D-67653 Kaiserslautern

Königstr. 154
D-67655 Kaiserslautern

Telefon: (0631) 200-0
Telefax: (0631) 17202
E-Mail: info@pfaff-industrial.com

Gedruckt in der BRD
Printed in Germany
Imprimé en R.F.A.
Impreso en la R.F.A.