

PFAFF



Supplement to the
instruction manual and parts list
for machines with
-948/51

1 Supplement to the instruction manual

1.01 Puller -948/51

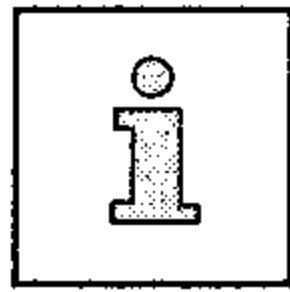

By permanently turning the puller roller, the puller enables to a great extent sewing without the workpiece shifting and puckering. The linear motor of the puller enables individual clearance space between the needle plate and puller roller.

All adjustments such as puller feed motion, clearance under the puller roller etc. can be made by changing the parameters (see Chap. 1.06 and 1.07).

1.02 Puller functions

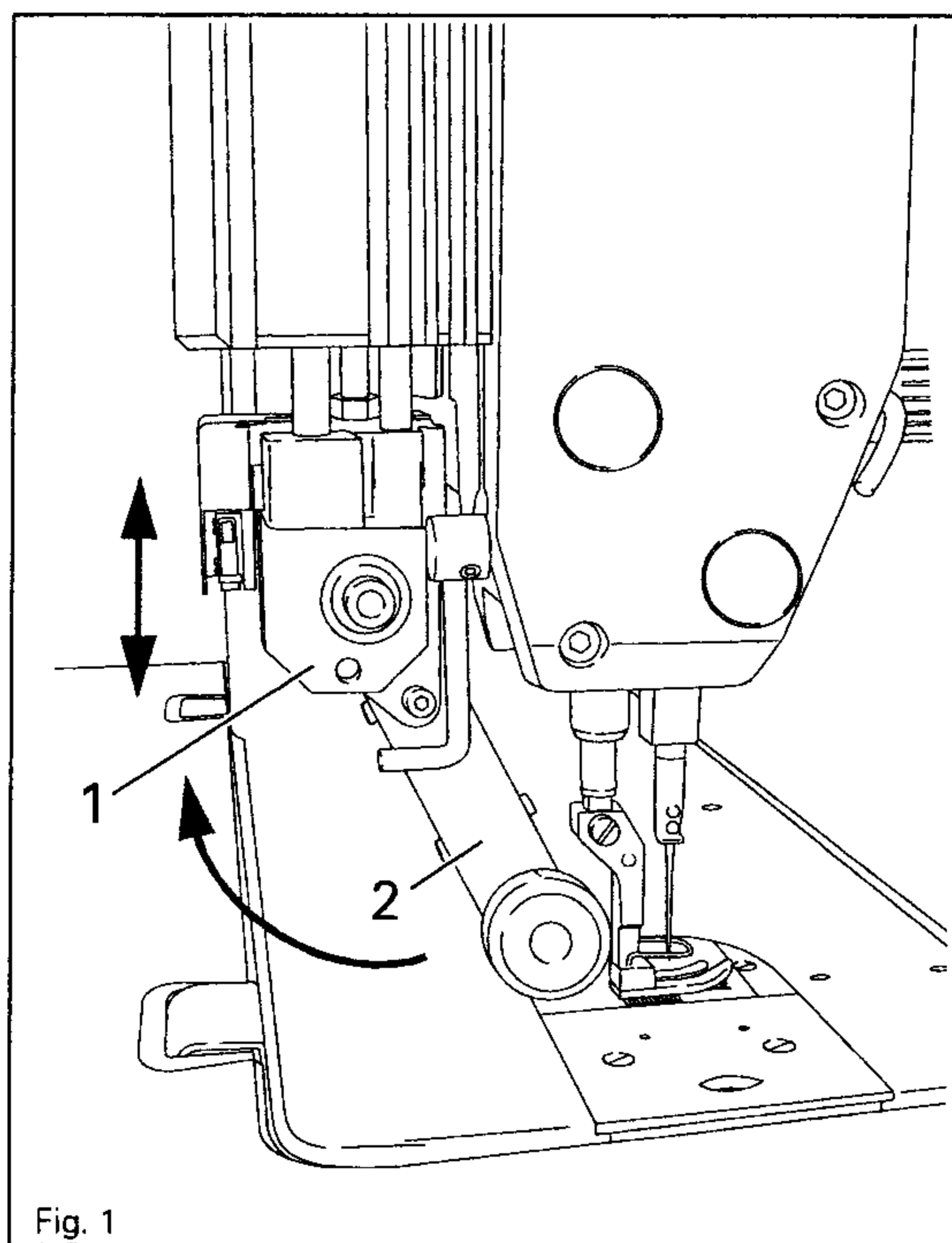

Engaging/disengaging the puller

- Raise the puller drive unit 1 until it locks into place and swing puller arm 2 back as far as possible. To engage the puller, follow the instructions in the reverse order.

Switching the puller on/off

- The puller is automatically switched on or off when the puller unit is engaged or disengaged.

Setting the puller feed motion

- The feed motion of the puller is set by means of parameters (see Chap. 1.07 List of parameters and the Motor Instruction Manual)

1.03 Functions of keys F1, F2, F3 and F5 (from control unit P52 MS)

The feed motion of the puller roller can be adapted to the workpiece material or the stitch length with the function keys F1-F3.

The values of the function keys F1-F3 can be programmed freely and set with the parameters 278 (F1), 279 (F2) and 280 (F3).

When the machine is restarted the F1-F3 value last used is reloaded and displayed on the operating panel. The function key which is actual use is made visible by an LED signal.

1.04 Programming example for the function key F1 with a stitch length of 2 mm

- Set the desired stitch length on the machine.



- Press the **Parameter input** key (LED is on)

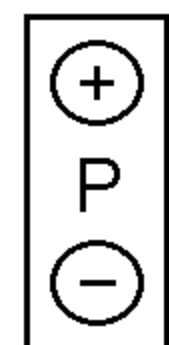

- Select the parameter group "200" by pressing +/- on the **P** key.

200 II

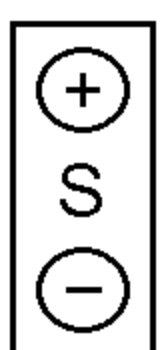
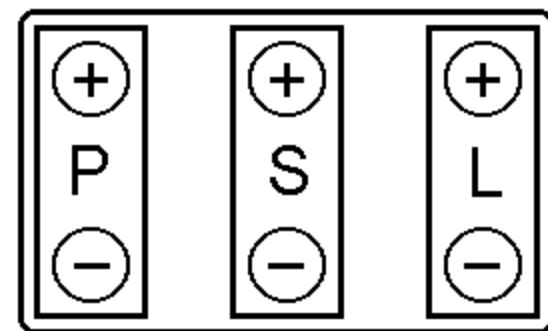

- Select parameter "278" for key F1 by pressing +/- on the **S** key.

278 10

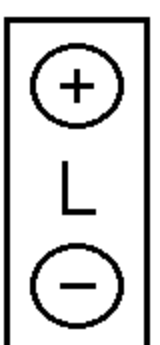
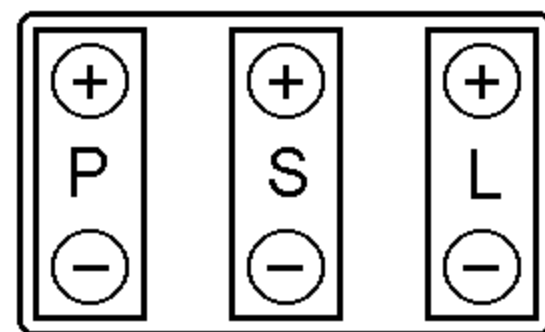

- Set a value of "20" which corresponds to the preset stitch length of 2mm by pressing +/- on the **L** key.

278 20

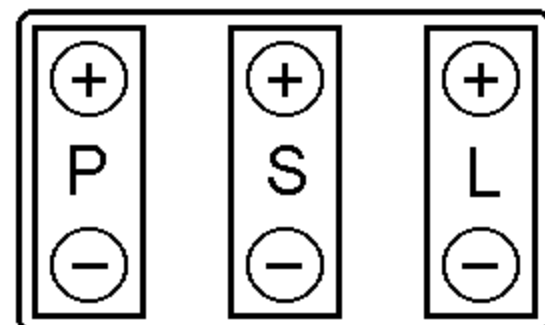

- Save the input by ending the parameter input (LED is off)
- Sew a test seam.
- If necessary increase or reduce the feed speed, i.e. **increase** or **reduce** the value "20" of parameter 278 (for the F1 key).
- Further stitch lengths or material differences can be programmed and requested for the F2 and F3 keys as described in this example.
- The F1-F3 keys can only be requested when the F5 key is activated.



For the puller -948/51 the presser foot pressure must be adapted to the sewing speed with adequate drag for the light pulling action of the puller wheel. If the presser foot pressure is too low, this has a negative influence on the stitch length.

1.05 Using standard presser feet

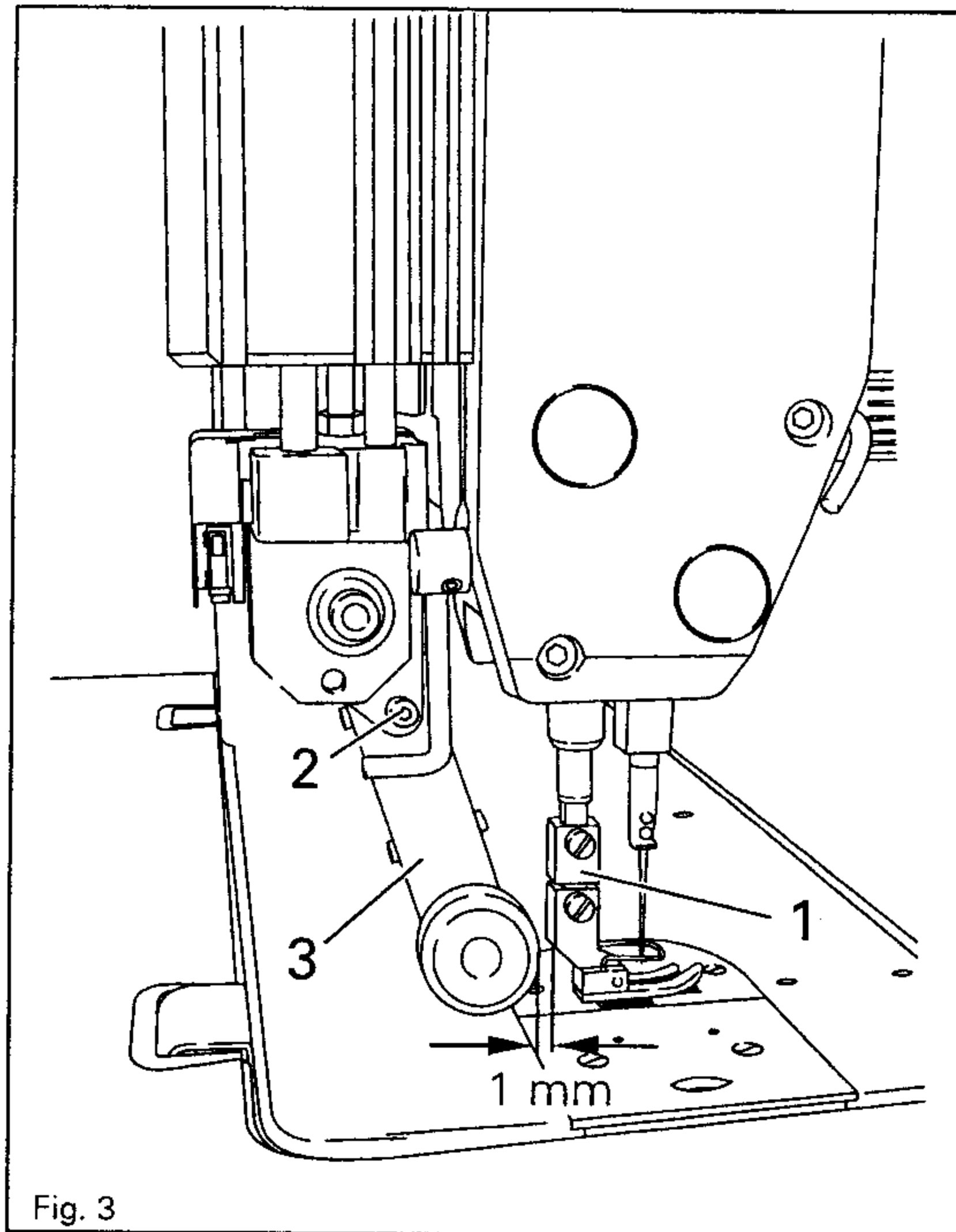

- With the adapter 1, which belongs to the accessories, standard presser feet can also be used.
- Mount adapter 1 as shown in Fig. 3.
- Loosen screw 2 and push puller arm 3 back.
- Screw the presser foot onto adapter 1.
- Adjust puller arm 3 so that there is a clearance of approx. 1 mm between the puller roller and the presser foot.
- Tighten screw 2.

1.06 Selecting and altering parameters



- Press and hold key PE and TE simultaneously.
- Switch on the machine.

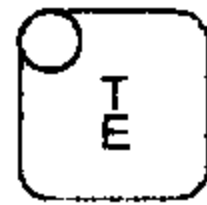

- Press the Parameter input key (LED on).

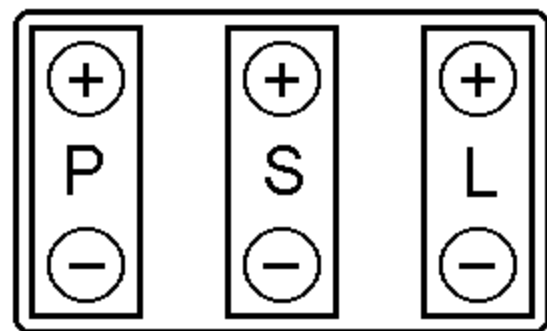

- By pressing +/- on the P key select the desired group, e.g. "200".

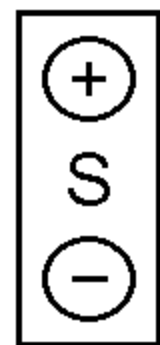
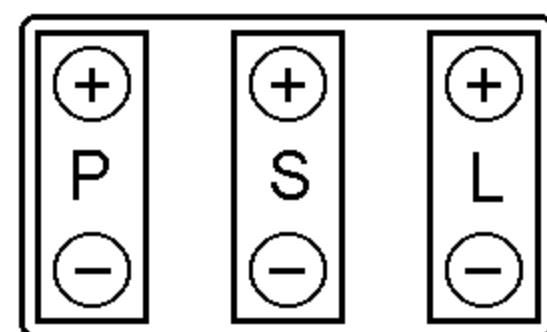
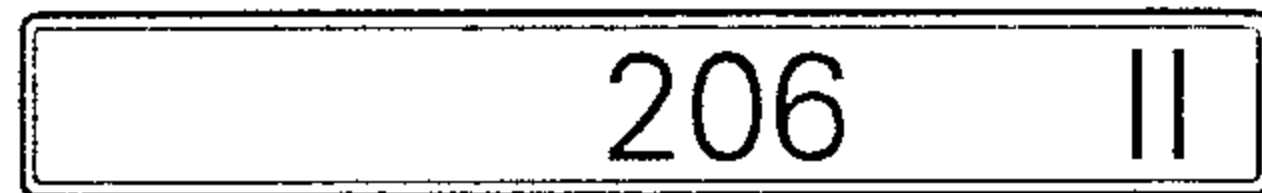

- By pressing +/- on the S key select the desired parameter, e.g. "252".

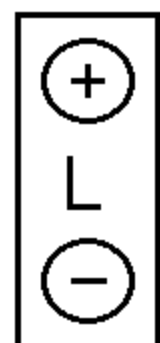
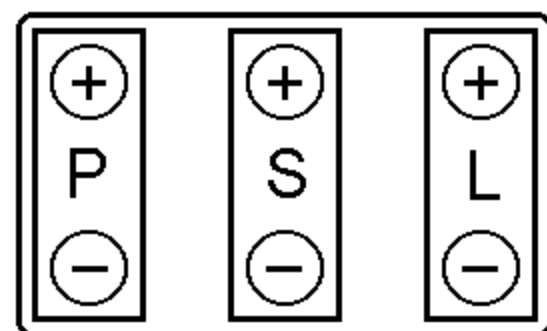
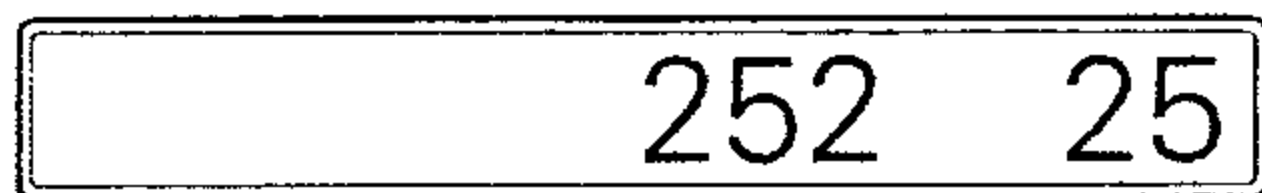

- Set the desired value (e.g. clearance under puller roller) by pressing +/- (key L).



- Save the input by ending the parameter input (LED off).

1.07

List of parameters

Group	Parameter	Description	Access level	Standard value
2	252	Clearance under puller roller on starting back tack approx. 4 mm	A, B, C	25
	253	Puller starting time in intermittent range (on the PFAFF 1051 and 1181) (on the PFAFF 1053 and 1183)	B, C	10
			B, C	70
	254	Throughput under the puller roller after cutting approx. 7 mm	B, C	35
	256	Basic presser of puller during sewing	B, C	8
	261	Starting properties of the puller roller	B, C	45
	262	Advance of the puller roller in intermittent operation	B, C	40
	278	Feed motion of the puller roller (F1 key) plus F5	A, B, C	20
	279	Feed motion of the puller roller (F2 key) plus F5	A, B, C	30
	280	Feed motion of the puller roller (F3 key) plus F5	A, B, C	50
289	Clearance under the puller roller during the inseam backtack (approx 4mm)	A, B, C	30	
3	302	Holding power of puller roller in the up position.	B, C	100
4	445	No. of stitches after the machines starts before the puller roller makes contact	B, C	0

Height of puller after trimming

If the down presser on the puller roller is too much, the motor driving the puller is not strong enough to overcome this stalling the puller and error (63 occurs)

The amount or rotation of the puller at speeds below 500 rpm.

Timing of the puller turning when sewing under 500 rpm

The tabular mentioned standard settings are basic settings and can be changed on request.

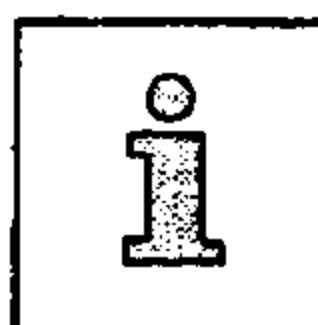

After an EPROM change carry out a master reset (please refer to the motor instruction manual).

For more information and displays see the motor instruction manual.