

SINGER
133W102,W103

21

USE ONLY SINGER OILS and LUBRICANTS

*They insure freedom from lubricating trouble and
give longer life to sewing equipment*

“Singer Oil for High Speed Sewing Machines”

(Cloth and Leather)

For all manufacturing sewing machines except where a stainless oil is desired.

“Singer Stainless Oil for High Speed Sewing Machines”

For all manufacturing sewing machines where a stainless oil is desired.

“Singer Motor Oil”

For oil-lubricated motors, power tables, transmitters and machinery in general.

“Singer Stainless Thread Lubricant”

For lubricating the needle thread of sewing machines for stitching fabrics or leather where a stainless thread lubricant is required.

NOTE: All of the above oils are available in 1 quart, 2 quart, 1 gallon and 5 gallon cans or in 55 gallon drums, and can also be supplied in customer's containers.

“Singer Gear Lubricant”

This specially prepared grease is recommended for gear lubrication on manufacturing sewing machines.

“Singer Ball Bearing Lubricant”

This pure grease is specially designed for the lubrication of ball bearings and ball thrust bearings of motors and electric transmitters, ball bearing hangers of power tables, etc.

NOTE: The above greases are furnished in ¼ lb. tubes and 1 lb. and 4 lb. tins.

Copyright, U. S. A., 1914, 1915, 1922, 1930, 1940 and 1941.
by The Singer Manufacturing Company
All Rights Reserved for all Countries

Form 2813w

INSTRUCTIONS

FOR USING AND ADJUSTING

SINGER SEWING MACHINES

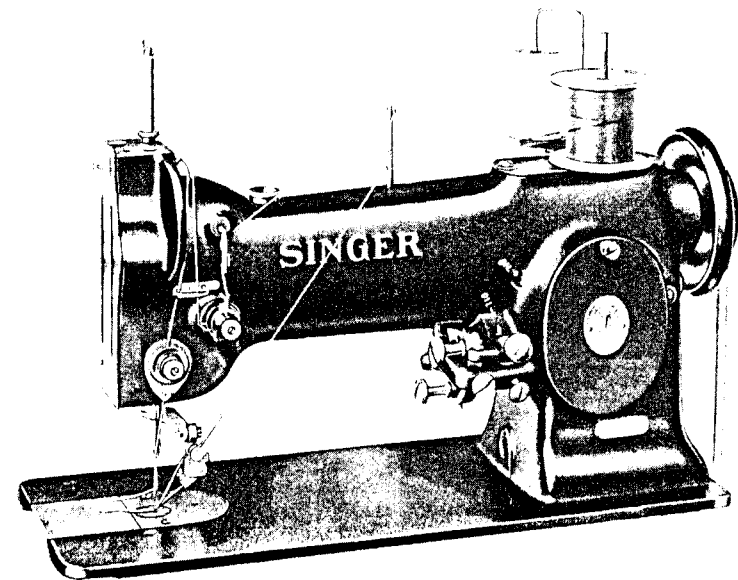

Machine 133w103 fitted with Cording Attachment

133w102 and 133w103

THE SINGER MANUFACTURING CO.

To all whom it may concern:

The placing or renewal of the name "Singer" (Reg. U. S. Pat. Off.) or any of the trade marks of The Singer Manufacturing Company on any machine that has been repaired, rebuilt, reconditioned, or altered in any way whatsoever outside a Singer factory or an authorized Singer agency is forbidden.

THE IMPORTANCE OF USING
GENUINE SINGER PARTS AND NEEDLES
IN SINGER MACHINES

The successful operation of Singer machines can only be assured if genuine Singer parts and needles are used. Supplies are available at all Singer Shops for the Manufacturing Trade and mail orders will receive prompt attention.

Genuine Singer Needles should be used
in Singer Machines.
These Needles and their Containers
are marked with the
Company's Trade Mark "SIMANCO." 1

Needles in Containers marked
"For Singer Machines"
are not Singer made needles. 2

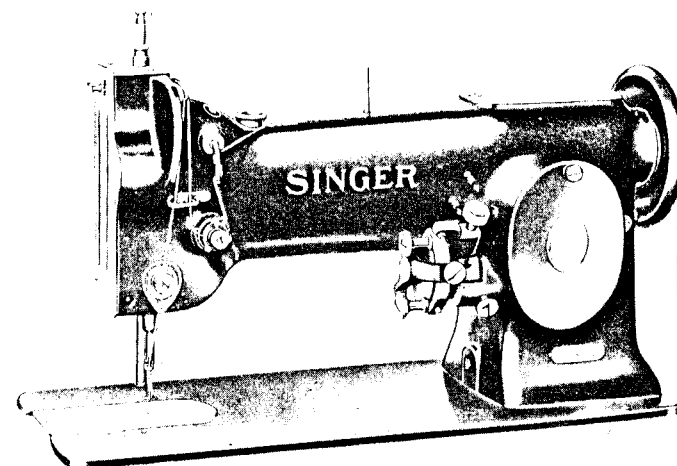

Machine 133W102 fitted for Flat stitch Embroidery

DESCRIPTION

Machine 133W102 is designed for producing flat stitch embroidery, Madeira eyelets, French knots, seed stitch, scallops, etc.

Machine 133W103 is fitted for flat stitch embroidery only, and has a cording attachment; otherwise it is the same as Machine 133W102.

These machines have a gear-driven rotary sewing hook and a bobbin case which are especially constructed to sew with left twist artificial silk. The sewing hook revolves in the opposite direction to that in machines designed for right twist thread.

The work is clamped in embroidery hoops which are passed under the needle and moved in the desired direction by the operator, there being no feeding mechanism.

The needle vibrates alternately to and from the operator, forming zigzag lock stitches. It can be made to vibrate up to $\frac{3}{16}$ inch, $\frac{3}{32}$ inch on each side of a zero line, as shown in Fig. 15, the width of the stitching being readily varied by the knee lever.

By shifting the hand lever (R, Fig. 17), the zero position of the needle can be moved forward $\frac{3}{32}$ inch and the stitching can then be varied any width up to $\frac{3}{16}$ inch to the rear of the zero position (see Fig. 16).

When desired, the needle vibrating mechanism can be locked to produce any width of stitching within the capacity of the machine, by tightening the thumb screw (U, Fig. 17).

The two stop screws (W and X, Fig. 17) are provided for limiting the extent of the vibrations of the needle when it is desired to produce varying widths of stitches within predetermined limits (up to $\frac{3}{16}$ inch).

To Oil the Machine

When the machine is received from the factory, it should be thoroughly cleaned and oiled.

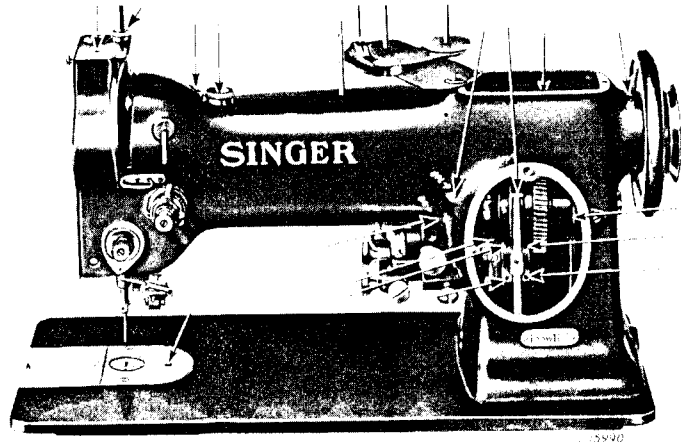

Fig. 3. Oiling Points at the Front of the Machine

Oil should be applied at each of the places indicated by arrows in Figs. 3, 4, 5 and 6. When the machine is in continuous use, it should be oiled at least twice each day.

Swing back the cover which is on top of the machine and oil the bearings which are thus uncovered, then replace the cover.

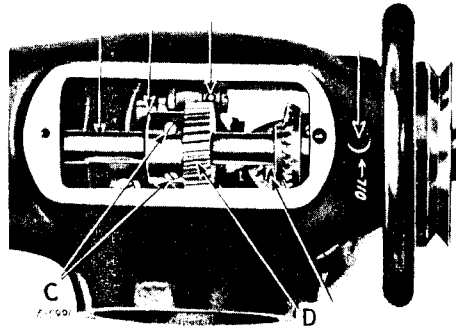

Fig. 4. Oiling Points Inside Arm of Machine
Also Adjustments on the Machine

Move the face plate aside and oil the wick and bearings shown in Fig. 5, then replace the face plate.

Occasionally apply a drop of oil to the bobbin case raceway in the hook.

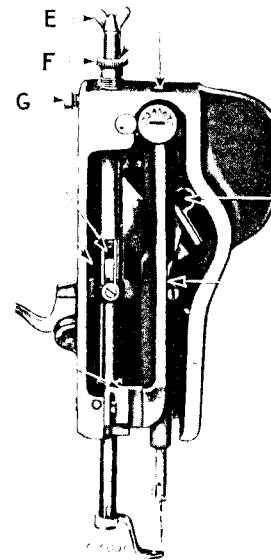

Fig. 5. End View of Machine,
Showing Oiling Points Also
Adjustments on Machine 133W102

Turn the machine back on its hinges and apply oil at the places shown by arrows in Fig. 6.

Occasionally remove the large screw (L, Fig. 6) and fill the gear case (M, Fig. 6) with Singer Gear Lubricant, a grease which is especially prepared for this purpose, then replace the screw (L).

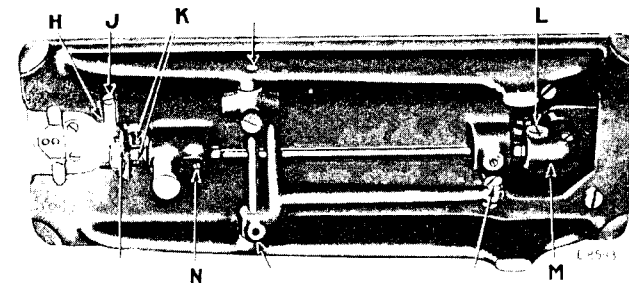

Fig. 6. Base of Machine, Showing Oiling Points
Also Adjustments on the Machine

Speed

The maximum speed recommended for Machines 133W102 or 133W103 is 2000 stitches per minute. The machine should be run slower than the maximum speed until the parts which are in movable contact have become thoroughly glazed by their action upon each other. When the machine is in operation, the balance wheel should turn over toward the operator.

Needles

Needles for Machines 133w102 and 133w103 are of Class and Variety 135x23 and are furnished in sizes 7, 8, 9, 10, 12, 14, 16, 18, 20 and 22.

The size of the needle to be used should be determined by the size of the thread which should pass freely through the eye of the needle.

Orders for needles must specify the quantity required, the size number, also the Class and Variety numbers separated by the letter x.

The following is an example of an intelligible order:

"100 No. 12, 135x23 Needles."

The best results will be obtained in using the needles furnished by the Singer Sewing Machine Company.

Thread

Use left twist artificial silk for the needle. Either right or left twist thread may be used for the bobbin.

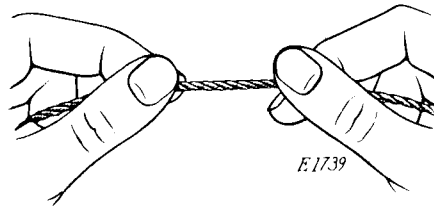

Fig. 7. How to Determine the Twist

Hold the thread as shown above. Then turn the thread over toward you between the thumb and forefinger of the right hand; if left twist, the strands will wind tighter; if right twist, the strands will unwind.

To produce a smooth stitch, soft finished thread of the same size should be used for both the needle and the bobbin.

To Remove the Bobbin

Turn the balance wheel over toward you until the needle moves up to its highest point. Reach under the bed of the machine with

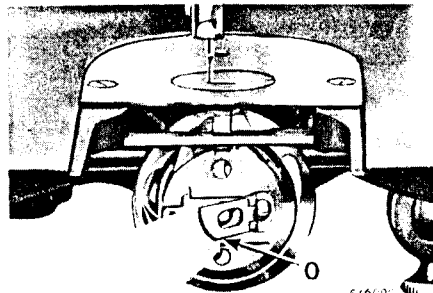

Fig. 8. Removing the Bobbin Case

the left hand, open the bobbin case latch (0, Fig. 8) and lift out the bobbin case. While the latch remains open, the bobbin is retained in the bobbin case. Release the latch, turn the open end of the bobbin case downward and the bobbin will drop out.

To Wind the Bobbin

(See Fig. 9)

Fasten the bobbin winder to the table with its driving pulley in front of the machine belt, so that the pulley will drop away from the belt when sufficient thread has been wound upon the bobbin.

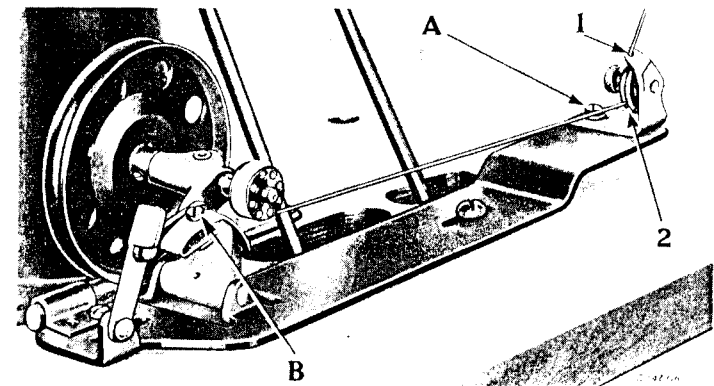

Fig. 9. Winding the Bobbin

Place the bobbin on the bobbin winder spindle and push it on as far as it will go.

Pass the thread down through the thread guide (1) in the tension bracket, around the back and between the tension discs (2). Then wind the end of the thread around the bobbin a few times, push the bobbin winder pulley over against the machine belt and start the machine.

When sufficient thread has been wound upon the bobbin, the bobbin winder will stop automatically.

If the thread does not wind evenly on the bobbin, loosen the screw (A) in the tension bracket and move the bracket to the right or left as may be required, then tighten the screw.

The amount of thread wound on the bobbin is regulated by the screw (B). To wind more thread on the bobbin, turn the screw inwardly. To wind less thread on the bobbin, turn the screw outwardly.

Bobbins can be wound while the machine is stitching.

To Thread the Bobbin Case

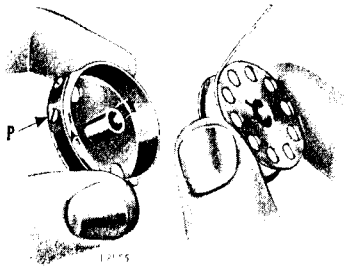

Fig. 10.

Hold the bobbin between the thumb and forefinger of the right hand, the thread drawing on top from the left toward the right.

With the left hand, hold the bobbin case open side

up, the tension spring being at the front (see Fig. 10) and place the bobbin into it.

Then pull the thread towards the left into the slot in the edge of the bobbin case, as shown in Fig. 11, draw the thread under the tension spring and into the second slot in the edge of the bobbin case; then pull the thread between the bobbin and

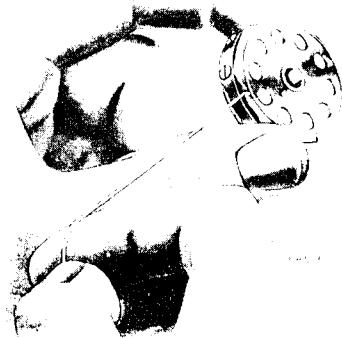

Fig. 11.

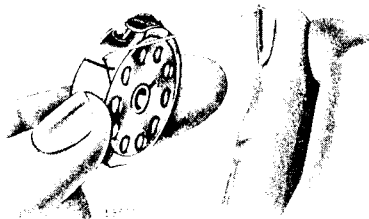

Fig. 12.

bobbin case and into the third slot in the edge of the bobbin case, then into the delivery eye, as shown in Fig. 12.

To Replace the Bobbin Case

After threading, take the bobbin case by the latch, holding it between the thumb and forefinger of the left hand, place the

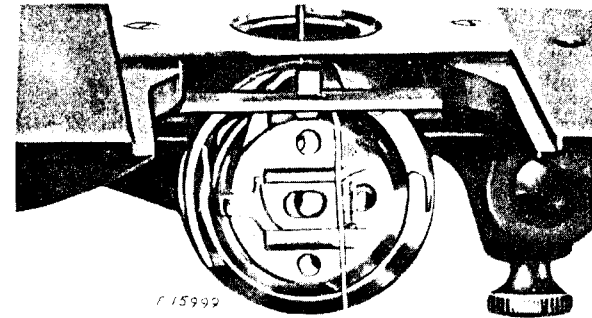

Fig. 13. Bobbin Case Threaded and Replaced

bobbin case on the center stud of the bobbin case holder, release the latch and press the bobbin case back until the latch catches the groove near the end of the stud. Allow about two inches of thread to hang free. (See Fig. 13).

To Set the Needle

Turn the balance wheel over toward you until the needle bar moves up to its highest point. Loosen the screw in the lower end of the needle bar and put the needle up into the bar as far as it will go, with the long groove of the needle toward the right, then tighten the set screw.

Upper Threading

(See Fig. 14)

Pass the thread from the unwinder or spool, from back to front through the hole (1) in the thread guide pin on top of the machine,

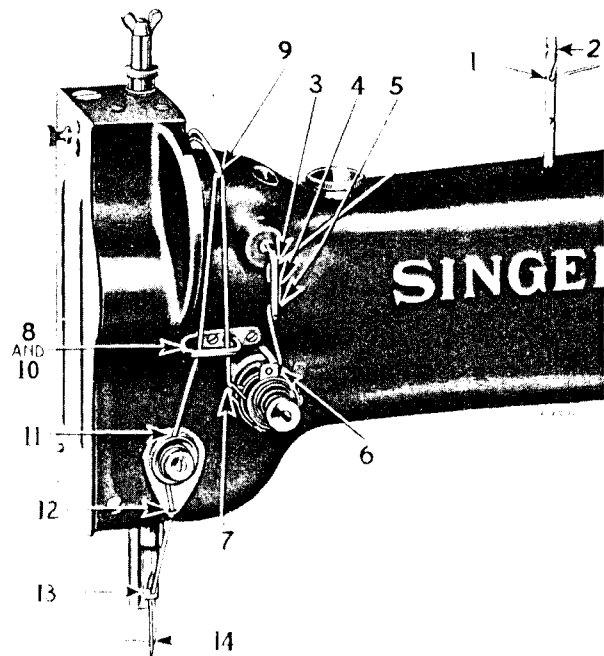

Fig. 14. Upper Threading

from right to left through the top hole (2) in the pin, from right to left through the top hole (3) in the thread retainer, from left to right through the middle hole (4) and from right to left through the bottom hole (5) in the retainer, around between the tension discs (6), under the thread controller spring (7), up through the thread guide (8), from right to left through the hole (9) in the thread take-up lever, back down through the guide (10), between the felt and the tension disc (11), down through hole (12) in the tension plate, through the guide (13) at the lower end of the needle bar, and from right to left through the eye of the needle (14). Draw about two inches of thread through the eye of the needle with which to commence sewing.

For threading of corder on Machine 133W103, see page 21.

To Adjust the Machine for Flat Stitch Embroidery

Two different forms of overseams can be produced with the zigzag stitching, namely: seams varying in width equally on each side of a line central of the stitching, as shown in Fig. 15, and seams varying in width from a straight line at the extreme front edge of the seam, as shown in Fig. 16.



Fig. 15. Flat Stitch Embroidery Produced with Needle Adjusted to Vibrate Equally on Each Side of a Center Line

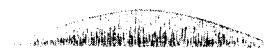

Fig. 16. Flat Stitch Embroidery Produced with Needle Adjusted to Vibrate to the Rear of a Zero Line

Each form of seam is governed by the lever (R, Fig. 17) at the right of the machine. To move this lever, loosen the set screw (T, Fig. 17), pull out the lever plunger (S, Fig. 17) and move the lever (R) up or down, as desired, allowing the plunger (S) to enter the hole in the arm, then tighten the set screw (T).

When the plunger (S) is in the lower hole (Y, Fig. 18) in the arm, the vibrations of the needle can be increased or decreased equally on each side of a line central of the stitching (see Fig. 15).

When the plunger (S) is in the upper hole (Q, Fig. 17) in the arm, the zero position of the needle is moved forward $\frac{5}{32}$ inch from the center line and the width of the stitching can then be increased or decreased from a straight line at the front edge of the seam (see Fig. 16).

To Regulate the Width of Zigzag Stitch

The width of zigzag stitch or extent of the vibrations of the needle is regulated by the knee lever which can be operated to make each form of seam any width varying from a straight line up to $\frac{3}{16}$ inch.

To Make Seams of Continuous Widths

Loosen the set screw (T, Fig. 17) and place the lever plunger (S, Fig. 17) in the lower hole (Y, Fig. 18) in the arm of the machine and press the knee lever until the needle vibrates to the desired width of seam, then tighten the large thumb screw (U, Fig. 17) in the lever (V, Fig. 17).

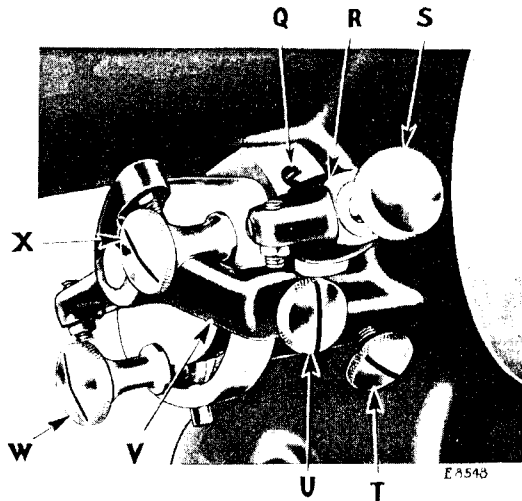

Fig. 17. Machine Adjusted for Flat Stitch Embroidery with Needle Vibrating Equally on Each Side of a Center Line

The two stop screws (W and X, Fig. 17) are provided for limiting the extent of the vibrations of the needle when it is desired to produce varying widths of stitches within predetermined limits less than $\frac{3}{16}$ inch wide. For example: If the extreme width of the seam is not to exceed $\frac{1}{16}$ inch, adjust the lower stop screw (W) as follows: Press the knee lever until the needle vibrates up to $\frac{1}{16}$ inch, hold the knee lever in this position and loosen the stop screw (W) and move it until it comes into contact with the lever (V, Fig. 17), then tighten the stop screw (W), and release the knee lever.

When it is desirable not to have the needle return to the zero position, adjust the upper stop screw (X, Fig. 18) as follows: Press

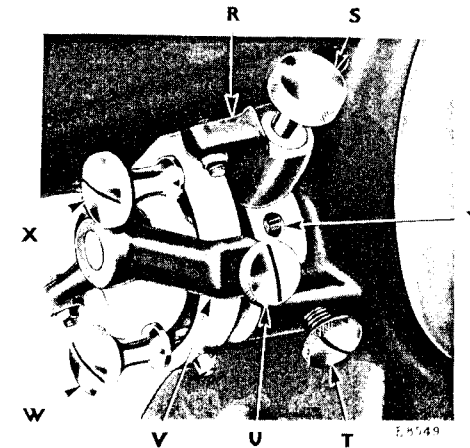

Fig. 18. Machine Adjusted for Flat Stitch Embroidery with Needle Vibrating to Rear of Zero Line Also Showing Machine Adjusted for Making Madeira Eyelets and Scallops

the knee lever until the needle vibrates the desired distance from its zero position, hold the knee lever in this position and loosen the stop screw (X) and move it until it comes into contact with the lever (V, Fig. 18), then tighten the stop screw (X) and release the knee lever. This will prevent the needle returning to its zero position.

Plunger "S"

Always tighten the set screw (T, Fig. 17) after moving the plunger (S, Fig. 17) in the lever (R, Fig. 17).

To Remove and Replace the Flat Needle Plate

To remove the flat needle plate (A₂, Fig. 19), draw the bed slide (Z, Fig. 19) to the left, as shown in Fig. 19. This will unlock the flat needle plate so that it can be lifted out of the recess in the throat plate.

To replace the flat needle plate (A2), have the bed slide (Z) withdrawn, as shown in Fig.19. Place the needle plate in the recess

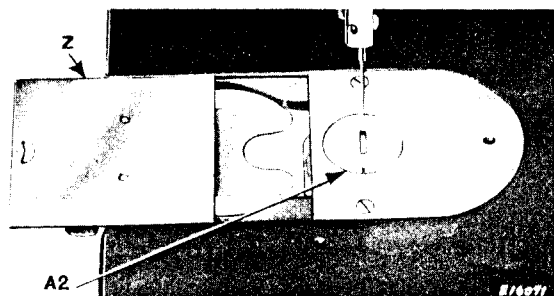

Fig. 19. Showing Bed Slide Withdrawn for Removal or Replacement of Flat Needle Plate

in the throat plate, having the pin in the throat plate enter the slot in the edge of the needle plate, then close the bed slide which will lock the needle plate in place. When the needle plate is in the proper position, it should be flush with the top of the throat plate.

To Operate the Machine for Flat Stitch Embroidery

Clamp the embroidery design in the embroidery hoops. The goods should be stretched smoothly and held firmly between the hoops.

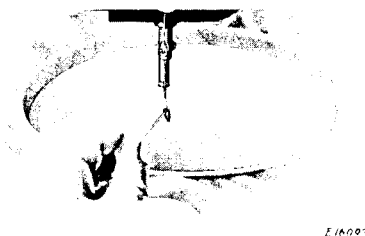

Fig. 20. Drawing up Bobbin Thread for Flat Stitch Embroidery

Place the goods under the needle as shown in Fig.20. With the left hand, hold the end of the needle thread, leaving it slack from the hand to the needle, turn the balance wheel over toward you until the needle moves down and up again to its highest point, thus catch-

ing the bobbin thread; draw up the needle thread and the bobbin thread will come up with it through the goods, as shown in Fig.20.

Hold both threads flat on the goods with the finger, as shown in Fig.21, then start the machine. After making a few stitches,



Fig. 21. Holding Threads for First Stitch for Flat Stitch Embroidery the threads can be cut close to the goods. Continue to run the machine, at the same time feeding the work from right to left with the hands. As the knee is pressed to the right against the knee lever, the needle will commence to vibrate until the desired width of stitch is obtained.

To Remove the Work

Let the thread take-up lever rest at its highest point, draw the work back and cut the threads close to the goods.

Relative Sizes of Spur Plates, Presser Feet and Punches for Madeira Eyelet Embroidery with Machine 133WI02

The following sizes of spur plates, presser feet and punches are recommended according to the size of eyelet:

Diameter of Eyelet Hole	Spur Plate	Presser Foot	Punch
$\frac{3}{32}$ inch	240858	240851	234470 or 234463
$\frac{7}{64}$ inch	234446	240852	234463 or 234462
$\frac{11}{64}$ inch	240859	240853	234467 or 234464
$\frac{1}{4}$ inch	234513	240854	234465

Note: Where two punches are recommended for the same size spur plate, better results can be obtained by using the first or smaller punch for light weight fabrics, and the second or larger punch for heavier fabrics.

To Remove and Replace the Eyelet Spur Plate

Follow the instructions given on pages 13 and 14, for removing and replacing the flat needle plate.

To Remove and Replace the Presser Foot

Loosen the wing nut (E, Fig. 5) at the top of the presser bar, and remove the presser foot by drawing it toward the left. In replacing the presser foot, press it toward the right as far as it will go, then tighten the wing nut.

To Adjust the Machine for Making Eyelets

Select the size spur plate and corresponding presser foot according to the size of eyelet required, as shown in the table on page 15, and place them in the machine as instructed on page 14 and above.

Loosen the set screw (T, Fig. 17) pull out the lever plunger (S, Fig. 17) and move the lever (R, Fig. 17) upwardly, allowing the plunger (S) to enter the upper hole (Q, Fig. 17) in the arm of the machine, then tighten the set screw (T).

Care must be taken at this time not to break the needle by having it come into contact with the eyelet spur plate.

Before starting the machine, move the knee lever alternately right and left and at the same time turn the balance wheel over toward you slowly until the needle vibrates toward the spur. When the needle is at the center of the spur, hold it in this position by means of the knee lever and at the same time loosen the lower stop screw (W, Fig. 18) and move it upwardly until it touches the lever (V, Fig. 18), then tighten the stop screw (W) and release the knee lever. The stop screw (W) will then act as a stop to prevent the needle striking the spur.

To Regulate the Outside Diameter of the Eyelets

The outside diameter of the eyelets can be increased or decreased by turning the indexed stud (B2, Fig. 22) at the left of the machine so as to bring the stitching closer to or farther from the center of the spur, as desired. This stud is marked with arbitrary numbers which appear through the hole in the face plate to indicate the position in which the needle is adjusted to vibrate.

To increase the outside diameter of the eyelet, loosen the set screw (C2, Fig. 22) and turn the stud (B2) until the number 1 is visible

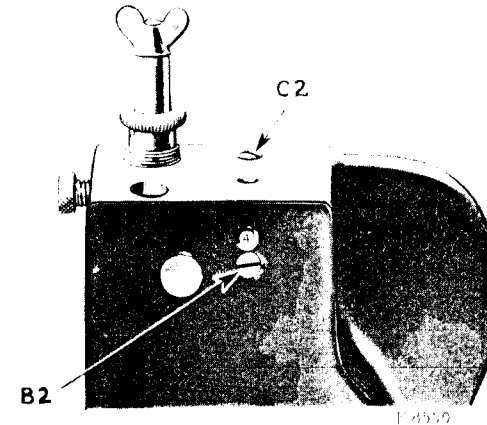

Fig. 22. Adjustment for Changing the Position of the Needle Vibrations or Regulating the Outside Diameter of the Eyelets

through the hole in the face plate. The needle will then move farthest forward (toward the operator) for making eyelets of the maximum outside diameter. To decrease the outside diameter of the eyelets, turn the stud (B2) until one of the higher numbers, as desired, appears through the hole in the face plate. When the number 8 is visible through the hole in the face plate, the needle will vibrate in the innermost position (toward the spur) and the outside diameter of the eyelet will be decreased to the minimum. When the needle is adjusted to vibrate for the desired diameter of eyelet, securely tighten the set screw (C2).

To Operate Machine 133w102 for Making Eyelets

For practice, place spur plate 234446 and presser foot 240852 in the machine. Clamp the goods in the embroidery hoops furnished with the machine. The goods should be stretched smoothly and held firmly between the hoops. Then make several holes in the piece of goods with punch 234463, using the mallet which is furnished with the machine for the purpose.

With the left hand grasp the presser foot and raise it as high as it will go, then place the goods under the presser foot so that the spur in the spur plate will enter one of the holes in the goods, then lower the presser foot upon the goods.

With the left hand hold the end of the needle thread, leaving it slack from the hand to the needle, turn the balance wheel over

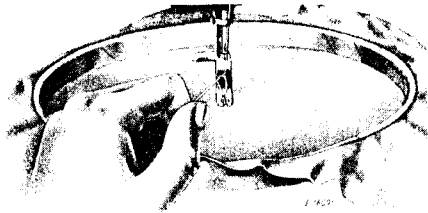

Fig. 23. Drawing Up the Bobbin Thread for Eyelet Work

toward you until the needle moves down and up again to its highest point, thus catching the bobbin thread; draw up the needle thread and the bobbin thread will come up with it through the goods, as shown in Fig. 23.

Hold both threads flat on the goods with the fingers as shown in Fig. 24; then start the machine. After making a few stitches,

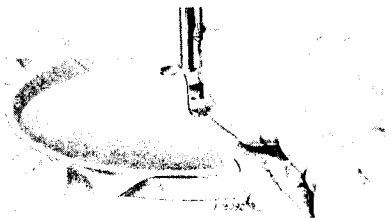

Fig. 24. Holding Threads for First Stitch of Eyelet

the threads can be cut close to the eyelet. Press the knee lever to the right as far as it will go. Continue to run the machine, at the same time turning the goods slowly in the direction followed by the hands of a clock. One or more revolutions of the work may be made to produce the desired effect, after which, without stopping the machine, release the pressure on the knee lever which will cause the needle to stop vibrating on the outer edge of the eyelet and produce a fastening or tying stitch. The knee should be held away from the knee lever until the machine is stopped.

To Adjust Machine 133w102 for Making Eyelets of Various Shapes

Remove the presser foot, lower the presser bar and place the flat needle plate in the machine, as instructed on page 14.

Adjust the machine the same as for eyelet embroidery, as instructed on page 16.

To Operate Machine 133w102 for Making Eyelets of Various Shapes

Clamp the fabric in the embroidery hoops furnished with the machine. The goods should be stretched smoothly and held firmly between the hoops.

Place the goods under the needle and turn the balance wheel over toward you with the right hand until the needle enters the goods on the outline of the eyelet which has been traced upon the material, then draw up the bobbin thread, as instructed on page 18.

Hold both threads flat on the goods as instructed on page 18, and start the machine. After making a few stitches, the ends of the threads can be cut close to the goods.

Continue to sew along the outline of the eyelet with a straight stitch, at the same time turning the work in the direction followed by the hands of a clock.



Fig. 25. Stages in Making Various Shapes of Eyelets

After outlining the eyelet with the straight stitch, as shown by A, Fig. 25, the fabric inside the stitching should be cut out with scissors as shown by B, Fig. 25.

Place the work under the needle and turn the balance wheel over toward you until the needle enters the goods on the line of straight stitching for the eyelet, then draw up the bobbin thread, as instructed on page 18.

Hold both threads flat on the goods as instructed on page 18, and start the machine. After making a few stitches, the ends of the threads can be cut close to the goods. Zigzag stitches can then be made across the line of straight stitching as shown by C, Fig. 25; and the work is also moved in a circular, clockwise direction until the straight stitching is completely covered. The eyelet can be worked around a second time with the zigzag stitch, if desired, as shown by D, Fig. 25.

To Regulate the Pressure on the Material for Eyelet Embroidery

The pressure on the material is regulated by the thumb screw (F, Fig.5) at the upper end of the presser bar. To increase the pressure, loosen the set screw (G, Fig.5) and turn the thumb screw (F) over to the right. To decrease the pressure, turn the thumb screw (F) over to the left. When the required amount of pressure is obtained, tighten the set screw (G).

To Adjust the Machine for Making Knots

Remove the spur plate and place the flat needle plate (A2, Fig.19) in the machine as instructed on page 14. Remove the presser foot and lower the presser bar.

Adjust the machine the same as for flat stitch embroidery, as instructed on page 11.

Clamp the fabric in the embroidery hoops furnished with the machine. The goods should be stretched smoothly and held firmly between the hoops.

Place the work under the needle as shown in Fig.20. With the left hand hold the end of the needle thread, leaving it slack from the hand to the needle, turn the balance wheel over toward you until the needle moves down and up again to its highest point, thus catching the bobbin thread; draw up the needle thread and the bobbin thread will come up with it through the goods, as shown in Fig.20.

Hold both threads flat on the goods with the finger, as shown in Fig.21; then start the machine. After making a few stitches, the threads can be cut close to the goods. Continue to run the machine, at the same time moving the work with the hands until the knot is the desired thickness.

To Adjust Machine 133w103 for Cording or Festoon Work

Adjust the machine for making seams of continuous widths as instructed on page 12.

Place the flat needle plate (A2, Fig.19) in position in the machine as instructed on page 14.

To Adjust Corder on Machine 133w103

Loosen the knurled thumb nut (02, Fig.26) and turn the adjusting screw (P2) to the right or left to bring the cord guide tube (D) in line with the center of the needle bar vibration, after which securely tighten the thumb nut (02).

Loosen the screw (R2, Fig.26) and set the end of the cord guide tube (D) flush with the right hand side of the needle slot in the needle plate, then securely tighten the set screw (R2).

To raise or lower the cord guide tube (D), turn the thumb screw (Q2, Fig.26) until the cord guide tube is set at the required height.

The corder may be moved upward out of operating position when not in use.

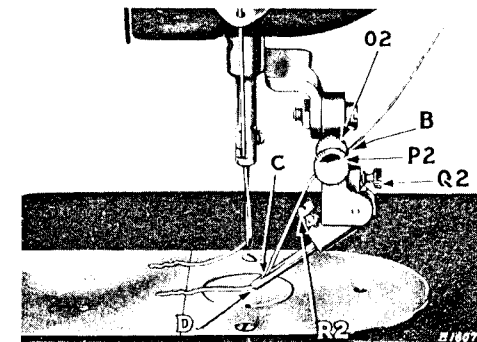

Fig. 26. Cord Guide Tube Threaded
Also Adjustments on Cording Attachment
(Machine No. 133w103)

To Thread the Cord Guide

Pass the cord from the thread unwinder or cord holder through the bottom hole in the thread guide pin on top of the machine, through the hole (B, Fig.26) in the cord tube holder, through the opening (C) in the cord guide tube and out through the hole (D) in the end of the tube. Draw enough cord through the tube so that it will be caught by the needle when commencing to sew.

To Operate the Machine for Cording

Clamp the goods in the embroidery hoops furnished with the machine and draw up the bobbin thread as instructed on page 14. Then start the machine and guide the work so that the cord will lie centrally under the zigzag stitching.

To Regulate the Tensions

The tension on the needle thread is regulated by the thumb nut (J2, Fig. 27) at the front of the tension discs on the front of the arm of the machine. To increase the tension, turn this thumb nut over to the right. To decrease the tension, turn this thumb nut over to the left.

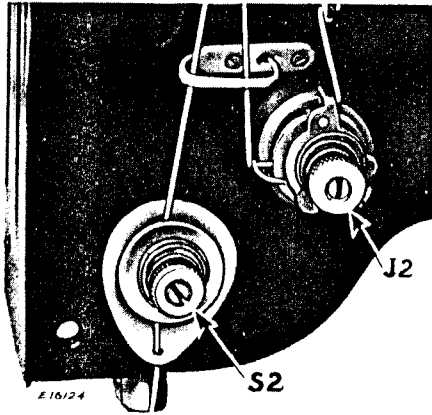

Fig. 27. Adjustment of Tension and Thread Check

When artificial silk is used the tension on the thread check, controlled by nut (S2, Fig. 27), should be set as lightly as possible to start, and may then be increased until the desired effect is obtained.

The tension on the bobbin thread is regulated by the screw (P, Fig. 10) near the center of the tension spring on the outside of the bobbin case. To increase the tension, turn this screw over to the right. To decrease the tension, turn this screw over to the left.

INSTRUCTIONS

FOR

ADJUSTERS AND MACHINISTS

To Time the Sewing Hook

Loosen the set screw (C2, Fig. 22) and turn the eccentric stud (B2, Fig. 22) until the number 4 on the stud is visible in the hole in the face plate, as shown in Fig. 22.

Remove the throat plate and turn the balance wheel over toward you until the lower timing mark across the needle bar is just visible at the bottom end of the needle bar frame on the upward stroke of the needle bar, as shown at F2, Fig. 29. If the needle bar and sewing hook are correctly timed, the point of the hook will be at the center of the needle and about 1/16 inch above the eye when the machine is adjusted with the needle in the zero position for flat stitch embroidery as instructed on page 11.

In case the sewing hook is not correctly timed, see that the eccentric stud (B2, Fig. 22) is set so that the number 4 is visible through the hole in the face plate, as instructed above. Then turn the balance wheel over toward you until the needle bar has descended to its lowest point and has risen until the lower timing mark across the needle bar is just visible at the end of the needle bar frame, as shown at F2 in Fig. 29. Now loosen the two screws (K, Fig. 6) in the hook and turn the hook until its point is at the center of the needle, as shown at G2 in Fig. 29, after which securely tighten the two screws in the hook.

To Set the Sewing Hook To or From the Needle

The point of the sewing hook should run as close as possible to the needle without touching it.

Turn the balance wheel over toward you until the point of the hook is at the center of the needle. Loosen the two screws (K, Fig. 6) in the hook, also loosen the screw (N, Fig. 6) which holds the hook shaft bushing. Then, holding the hook firmly against the bushing, move the hook and bushing to the right or left, as required, until the point of the hook is as close to the needle as possible without touching it, then securely tighten the screws (K and N).

To Remove the Sewing Hook

Remove the screw (J, Fig. 6) from the bobbin case stop and remove the bobbin case stop (H, Fig. 6). Then loosen the two screws (K, Fig. 6) in the sewing hook and remove the hook from the hook shaft, being careful to have the needle bar raised to its highest point.

To Time the Needle Vibrating Cam

The needle vibrating cam should be timed so that the needle moves forward and backward only when it is out of the goods.

In case the needle vibrating cam is not correctly timed, swing back the cover at the top of the machine as shown in Fig. 4 and loosen the two screws (C, Fig. 4). Then press the knee lever to obtain the maximum throw of the needle and at the same time turn the balance wheel over toward you until the point of the needle rises about 1/4 inch above the needle plate. When the needle is in this position, hold the balance wheel stationary and turn the gear (D, Fig. 4) which drives the needle vibrating cam, so that the needle will commence its vibrating movement at this point, then securely tighten the two screws (C).

Thread Controller

The function of the thread controller spring (N2, Fig. 30) is to hold back the slack of the needle thread until the eye of the needle

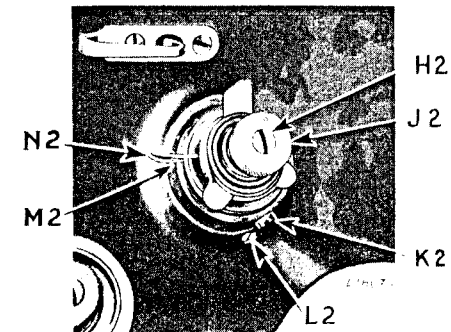

Fig. 30. Adjustment of Thread Controller

nearly reaches the goods in its descent, as without this controlling action of the spring, the slack thread or silk (more especially silk) will sometimes be penetrated by the point of the needle as the needle is descending.

The thread controller spring (N2) should be set so that when the eye of the needle nearly reaches the goods on the downward stroke of the needle bar, the spring will rest against the stop (M2, Fig. 30). To adjust the thread controller spring stop (M2), loosen the screw (K2, Fig. 30) and turn the stop (M2) around to the desired position, then tighten the screw (K2).

To regulate the tension on the thread controller spring (N2), loosen the set screw (L2, Fig. 30) and using a screwdriver, turn the tension stud (H2, Fig. 30) over to the right or left, as required, then tighten the set screw (L2). If a tight stitch is desired, the tension on the thread controller spring should be heavy. If a loose stitch is desired, the tension on the thread controller spring should be light.