

Yamato[®]

Instruction Manual

HIGH SPEED FLAT BED CHAINSTITCH MACHINE

VF2300M CLASS

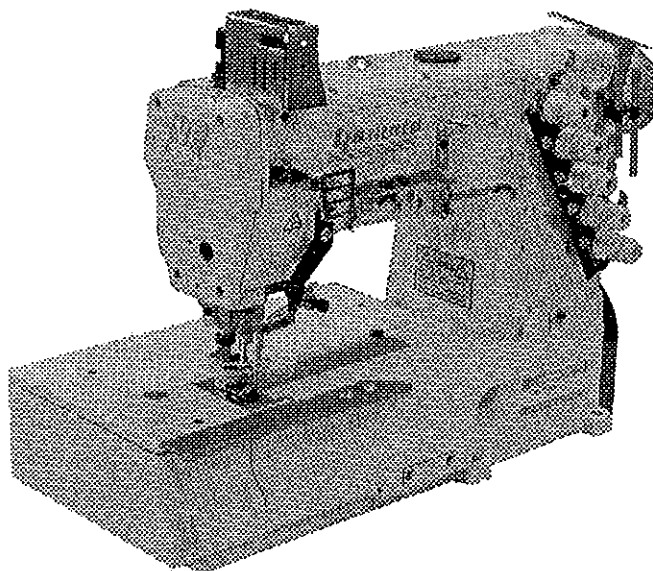

Thank you for having purchased the Model VF2300M series.

Before using your VF2300M series, please read this instruction manual and understand the contents well.

After reading this instruction manual, please keep it in a location where it is easy to access for operators.

CONTENTS

1. Installation	1
1-1 Diagram for cutting Table (semi-submerged type)	1
1-2 Installing Supporting Board(semi-submerged type)	2
1-3 Fixing Belt Cover	2
1-4 Motor and Belt	3
2. Sewing speed and turning direction	4
3. Lubrication	5
3-1 Lubricating oil to be used	5
3-2 Feeding oil	5
3-3 Oil Sight Gauge and Oil Sight Top Nozzle	5
3-4 Changing oil	5
3-5 Checking and replacing Oil Filter	6
4. Proper operation	7
4-1 Needle system	7
4-2 Fixing Needle	7
4-3 Threading	7
4-4 Thread tension	8
4-5 Pressure of Presser Foot	8
4-6 Adjusting Presser Foot	8
4-7 Adjusting stitch length	9
4-8 Adjusting differential feed	10
4-9 "HR" and "SP" Devices	11
5. Adjusting Sewing Machine	12
5-1 Needle thread tension	12
5-2 Top cover thread tension	13
5-3 Looper thread tension	13
5-4 Position of Looper Thread Take-up	14
5-5 Removing Presser Foot and amount of Presser Foot	15
5-6 Relation between Needle and Stitch Plate	15
5-7 Fixing angle and height of Looper	16
5-8 Movement of Looper to the right	16
5-9 Using Timing Gauge	17
5-10 Height of Needle Bar	17
5-11 Longitudinal position of Needle and Looper	18
5-12 Needle and Needle Guard(Rear)	19
5-13 Needle and Needle Guard(Front)	19
5-14 Height of Feed Dogs	20
5-15 Needle and Spreader	20
6. Specifications	22

1. Installation

1-1 Diagram for cutting Table (semi-submerged type)

Applicable models: VF2300M class

Note: Refer to the instruction manual of motor for the dimension of motor installation hole: A, B, C, and D.

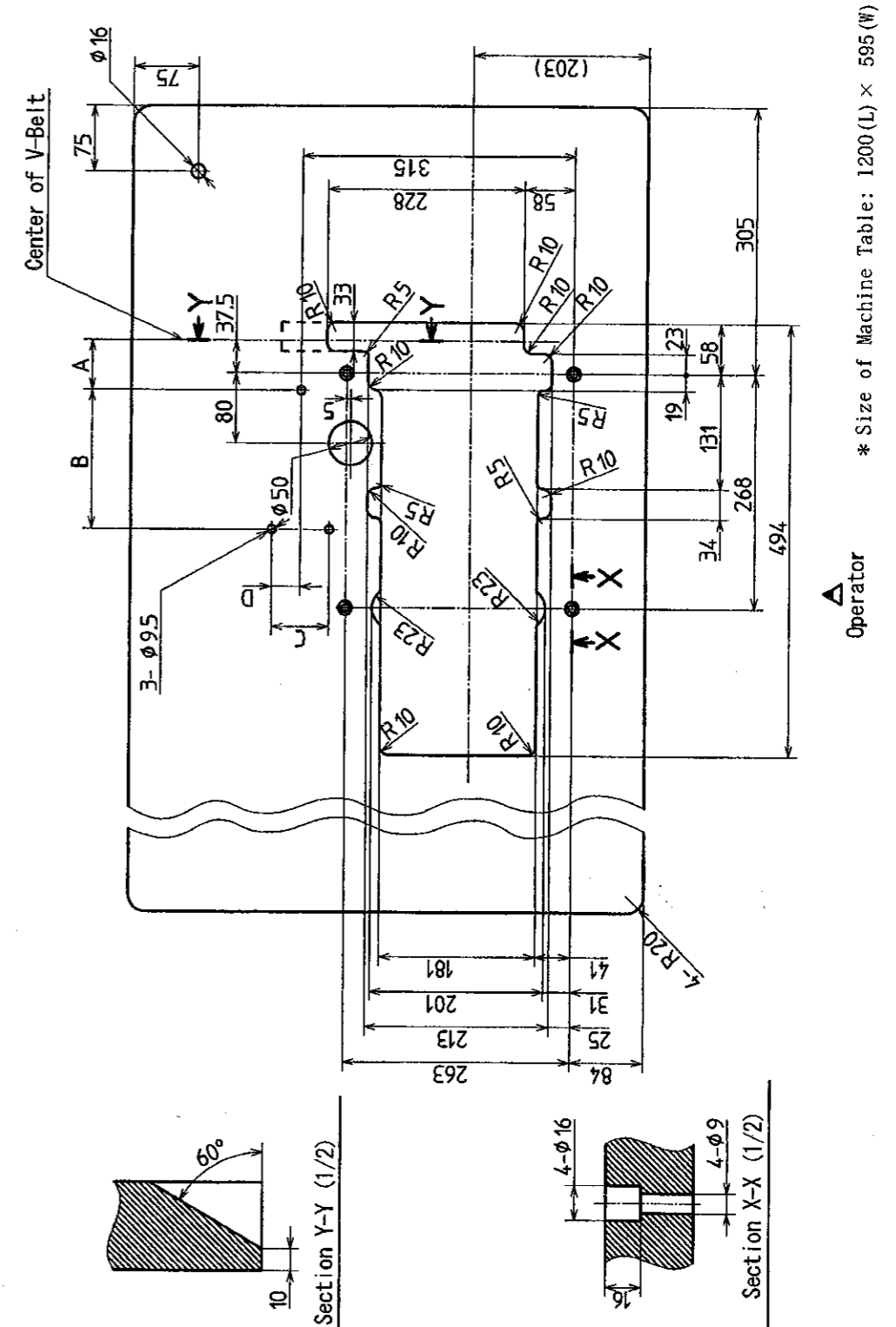

1-2 Installing Supporting Board (semi-submerged type)

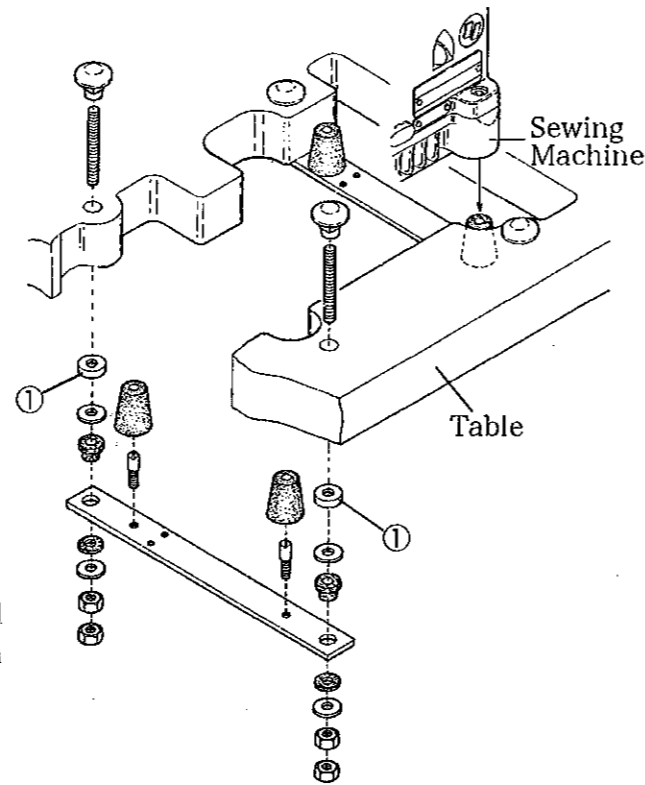
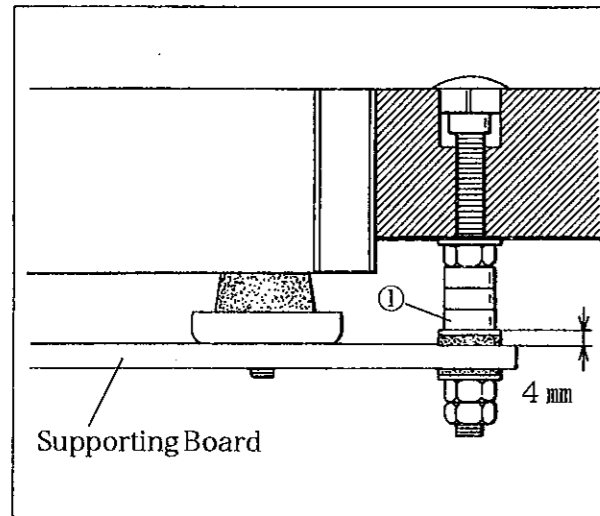

Referring to the figure, install the machine correctly. After fixing Screws on Supporting Board, fix the Board to Table. Then put Rubber Cushions on the Screws on which mount the machine securely.

☆Required number of Spacer①

VF2300M class

thickness of Table	number of Spacer ①
40mm	3pcs. × 4=12pcs.
45mm	2pcs. × 4=8pcs.
50mm	1pc. × 4=4pcs.

1-3 Fixing Belt Cover

Fix Belt Cover as shown in the figure.

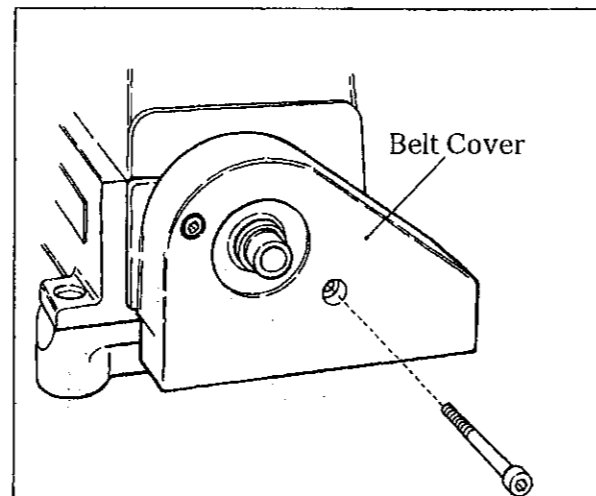

1-4 Motor and Belt

Use Clutch Motor of 3-phase, 2-pole 550W (3/4HP) and V-Belt of M-type. Position Motor so that its center aligns with the center of Machine Pulley when the Pulley is shifted to the left by treading Pedal.

Diameter of Motor Pulley (mm)	Rotation per minute of Machine (rpm)	
	50Hz	60Hz
85mm		4600
90mm		4900
95mm		5200
100mm	4500	5500
105mm	4700	5700
110mm	5000	6000
115mm	5200	
120mm	5400	
125mm	5600	
130mm	5800	

* The diameters of Pulleys on the market are at intervals of 5 mm; the above measurements are the nearest ones to the calculated value.

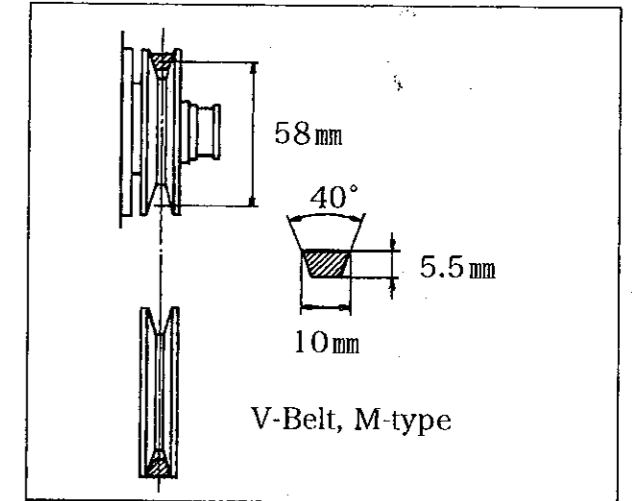

2. Sewing speed and turning direction

The maximum sewing speed and ordinary speed are shown in the table below.

To ensure your machines optimal performance long life, it is recommended to rotate at the speed about 15 - 20% lower than max. speed for initial 200 hours (about 1 month) and then at ordinary speed.

The turning direction of Pulley① is clockwise like Handwheel② as shown in the figure.

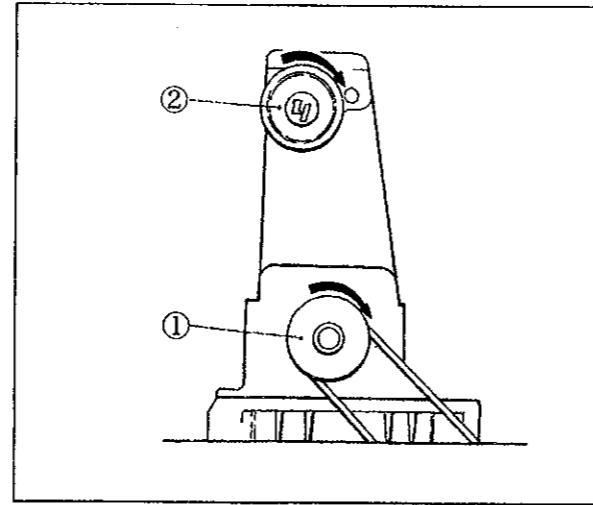

model	max. sewing speed	ordinary sewing speed
VF2300M class (with Top Cover Thread Mechanism)	6000 rpm	5500 rpm

3. Lubrication

3-1 Lubricating oil to be used

The YAMATO SF OIL No. 28 should be used as lubricating oil.

3-2 Feeding oil

Be sure to replenish it with oil up to the upper line of Oil Sight Gauge③ by removing rubber Seal Plug① indicated "OIL-IN" before operation.

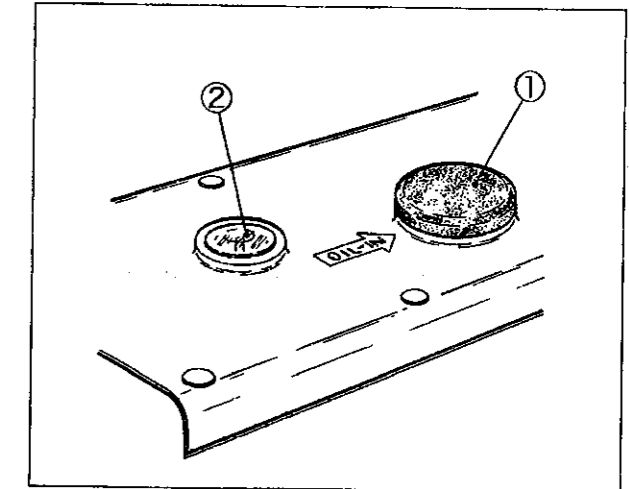

3-3 Oil Sight Gauge and Oil Sight Top Nozzle

Check Oil Sight Gauge③ everyday before operating machine and if the oil is below the lower line, supply oil.

Make sure that oil comes out of Nozzle②.

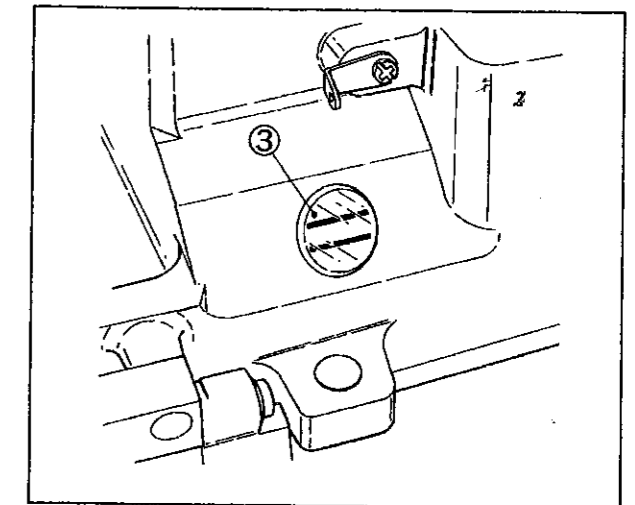

3-4 Changing oil

To ensure your machine optimal performance long life, oil must be changed completely after 250-hour operation.

Change oil as follows:

- (1) Remove V-Belt from Pulley and remove machine from table.
- (2) After removing Screw④, drain oil. Take care not to smear V-Belt with oil.
- (3) After draining oil, be sure to tighten Screw④.
- (4) For replenishing oil, refer to 5-2 "Feeding oil".

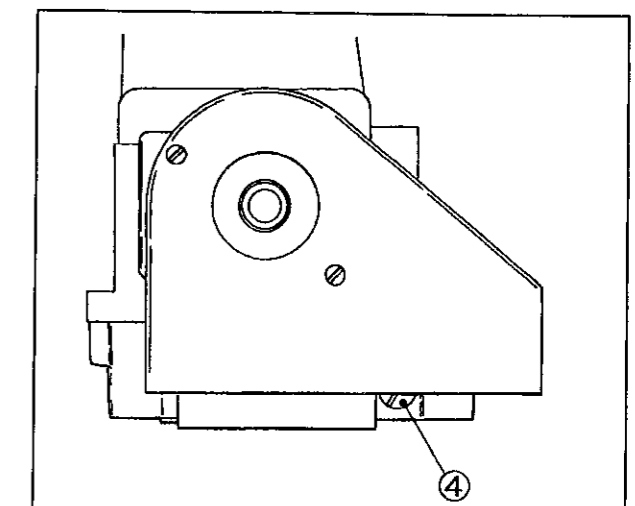

3-5 Checking and replacing Oil Filter

When Oil Filter ① is clogged with dirt, the proper lubrication is impossible.

Check Filter every 6 months. When the oil does not or very little comes out of Nozzle though sufficient oil is in reservoir, check the Filter.

To check Oil Filter, remove Oil Filter Cap ②.

When Oil Filter is clogged, replace it.

Note: Be careful not to spill the oil on Filter when removing Oil Filter Cap.

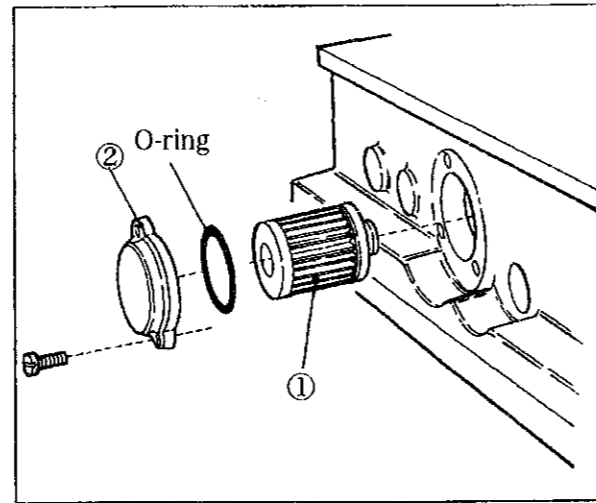

4. Proper operation

4-1 Needle system

Needle to be used is Schmetz or Organ UY128GAS. There are many Needle sizes and most suited size should be selected depending on thickness and kind of material.

Japanese sizes	9	10	11	12	13	14
Metric sizes	65	70	75	80	85	90

4-2 Fixing Needle

When replacing Needle, fix it correctly with its scarf just facing backward as shown in the figure.

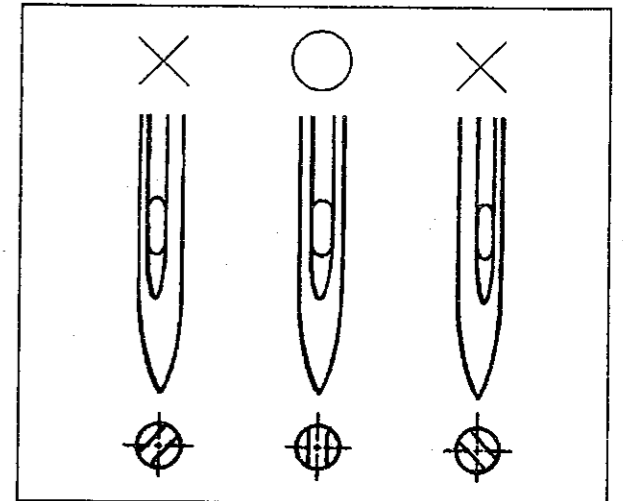

4-3 Threading

Thread correctly referring to the figure.

Incorrect threading may cause troubles such as skipping stitch, thread breakage, uneven seam.

A, B, C: needle thread, D: top cover thread, E: looper thread

* The figure shows the threading for 3-needle machine. (For 2-needle machine, 2 needle threads are required.)

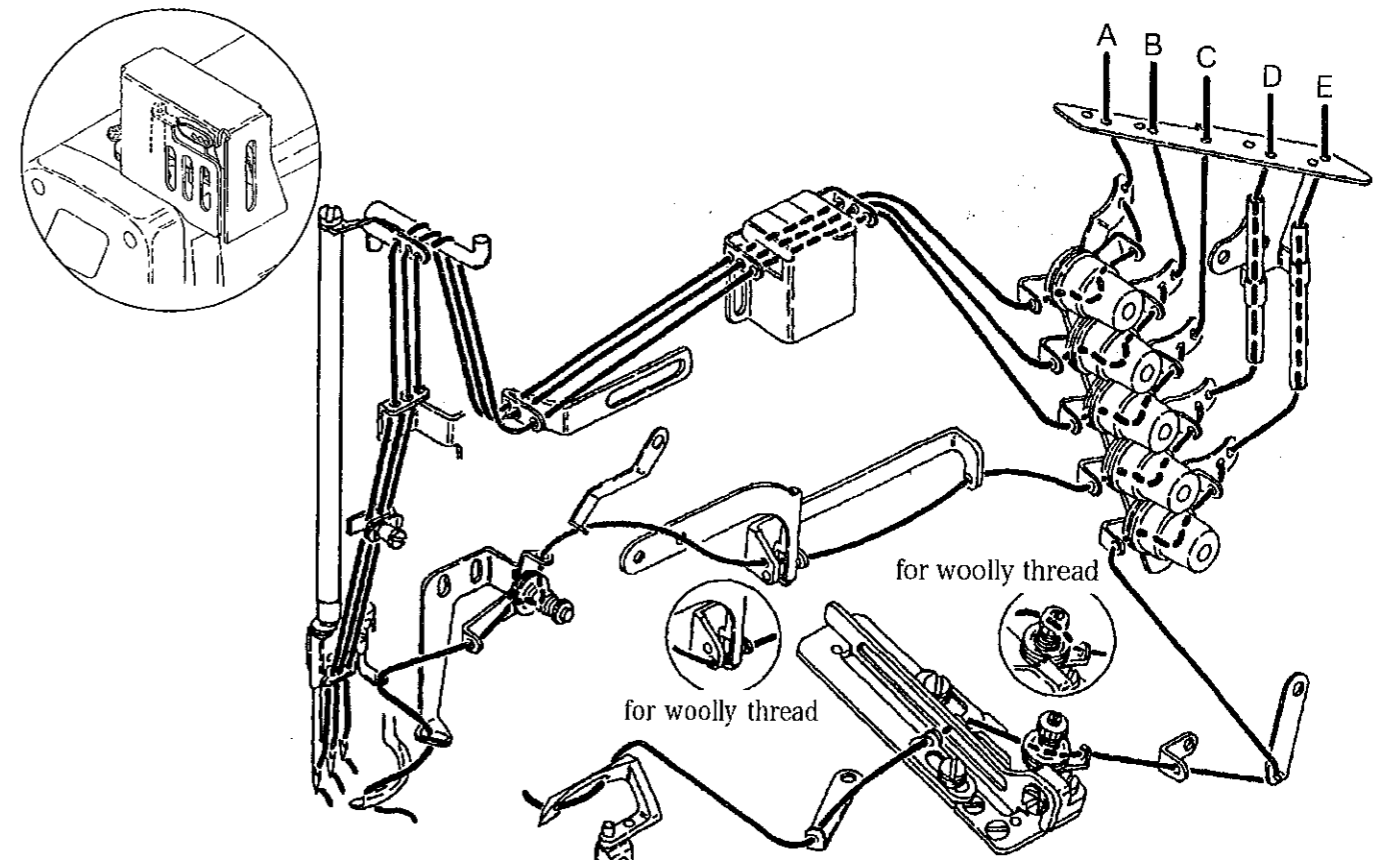

4-4 Thread tension

Thread tension changes according to the thread to be used, needle distance, stitch length, etc.

Minimize thread tension according to the sewing condition so long as stable stitches can be formed.

Note: Refer to the clause regarding thread tension of "Adjusting Sewing Machine" on pages 12 -14.

4-5 Pressure of Presser Foot

6-5 Pressure of Presser Foot

To increase pressure, loosen Lock Nut ① and turn Adjusting Screw ② to clockwise.

To decrease, turn the Screw ② to counterclockwise.

The pressure should be minimized so long as stable stitches can be formed.

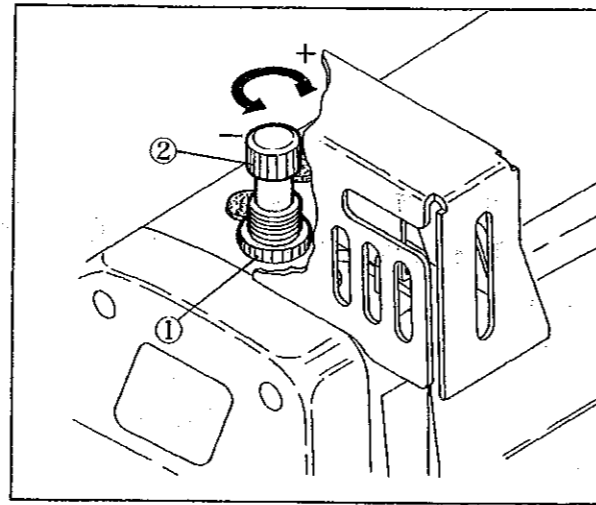

4-6 Adjusting Presser Foot

For adjusting lateral position of needle drop point of Presser Foot ③, loosen Screw ④ and move the tip of Presser Foot laterally against it so that the needle drops into the center of needle drop point and then tighten Screw ④.

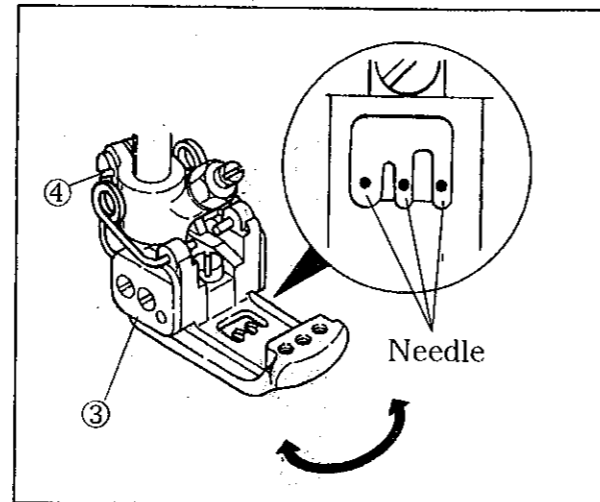

4-7 Adjusting stitch length

⚠ CAUTION

Whenever stitch length is adjusted, be sure to turn OFF the power and check that the motor has stopped completely. Otherwise, you may be injured.

Stitch length can be adjusted continuously from 1.4mm to 3.6mm.

The table below shows a number of stitch per inch and per 30mm.

stitch length (mm)	stitches per	
	inch	30mm
3.6	7	8
2.4	10.5	12.5
1.4	18	21

☆ Changing stitch length

Press Push-button ① with left hand lightly until its tip can be noticed to touch inner parts.

Keep pressing lightly, turn Handwheel ② with right hand until the Pushbutton drops in, then press in the Pushbutton strongly and turn Handwheel ②.

When getting graduation "L" closer to the dot ③ by turning Handwheel to clockwise, the stitch length becomes long.

At the position "L", the stitch length is about 3.6mm.

When getting graduation "S", closer to the dot ③ by turning Handwheel ② to counterclockwise, the stitch length becomes short. At the position "S" the stitch length is about 1.4mm.

Even with the same graduation, the stitch length varies according to the kind and thickness of fabrics and amount differential, etc.

In that case, readjust Handwheel ② for proper position.

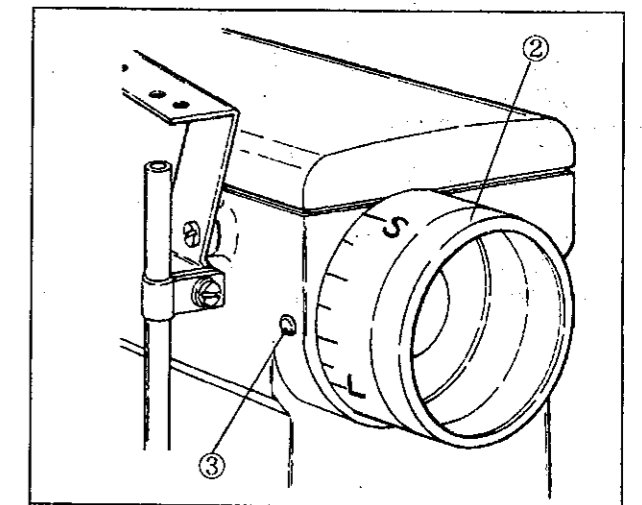
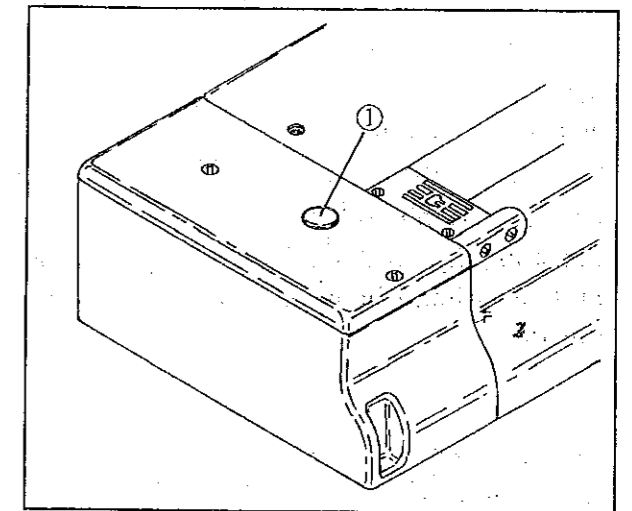

4-8 Adjusting differential feed

- (1) Normal differential feed (gather sewing)

Loosen Nut① and move Lever② up and down and set it at the desired position by tightening Nut①.
When Lever is set at graduation (Long)③, the ratio of main feed to differential feed is 1 : 1.
To obtain normal differential feed, raise the Lever above the graduation③.
Graduations of upper part show 1 : 1.25, 1 : 1.5, 1 : 1.75, 1 : 2 in order from the bottom.
- (2) Reverse differential feed (stretch sewing)

To obtain reverse differential feed, lower the Lever below the graduation③.
When it is set at "S", the ratio of main feed to differential feed is 1 : 0.7.
- (3) Adjustment of differential feed during operation

To adjust differential feed during operation, connect a Chain to Lever.
Fix Stop④(2pcs.) at the desired position to set upper and lower limits between which Lever is moved up and down.

☆ The range of differential ratio varies according to the stitch length.
Please refer to the table below.

stitch length	max. normal differential ratio	max. reverse differential ratio
3.6mm	1:1.2	1:0.7
2.5mm	1:1.6	1:0.7
2.0mm	1:1.8	1:0.7
1.4mm	1:2	1:0.7

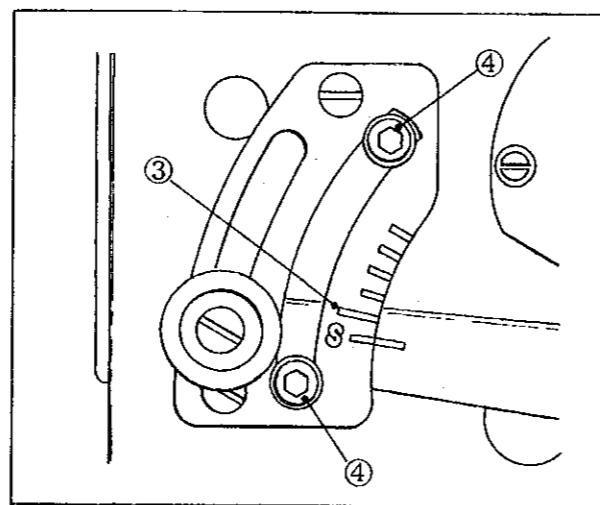
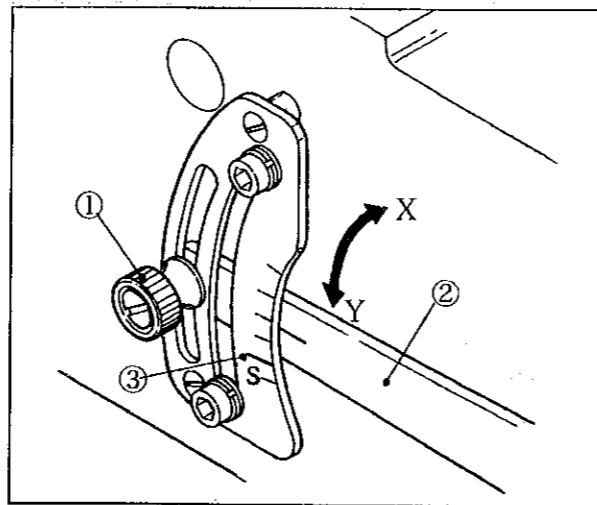

4-9 "HR" and "SP" Devices

Sometimes heat generated on the needle by the friction with the material at high speed operation causes such troubles as thread breakage, skipping stitch and enlargement of needle hole on the fabrics especially when using synthetic threads and fabrics.
To reduce these troubles, "HR" Device (Needle Point Cooling Device) and "SP" Device (Needle Thread Oiling Device) are attached as the standard equipment.
Most effective oil is silicone system.

Note: Open Seal Plug① of HR Container and Lid② of SP Container and check the oil quantity.
If it is running short, supply it.

We recommend to use "HR" and "SP" Devices with oil.
If the oiling is not necessary judging from sewing condition, it will be better for thread and needle not to touch dry Felt in the containers.

CAUTION

- ◇ When the device is not used, remove the felt③ ④ from the device. If it is left in the device, the sewing condition may be adversely affected.
- ◇ When silicone oil is adhered to other than the device, be sure to wipe it off. If this precaution is not observed, a failure may result in the machine.

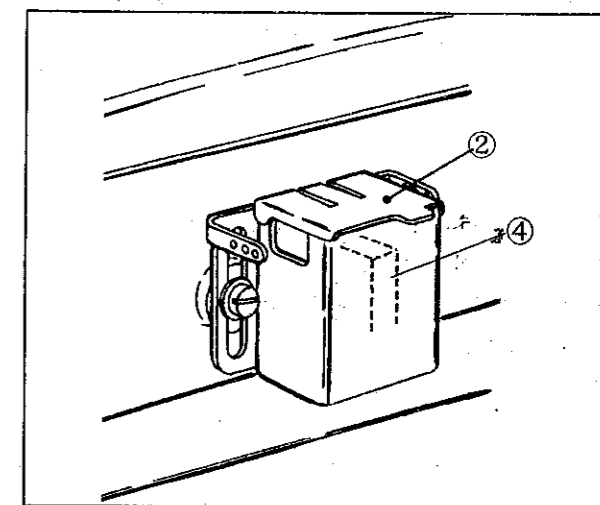
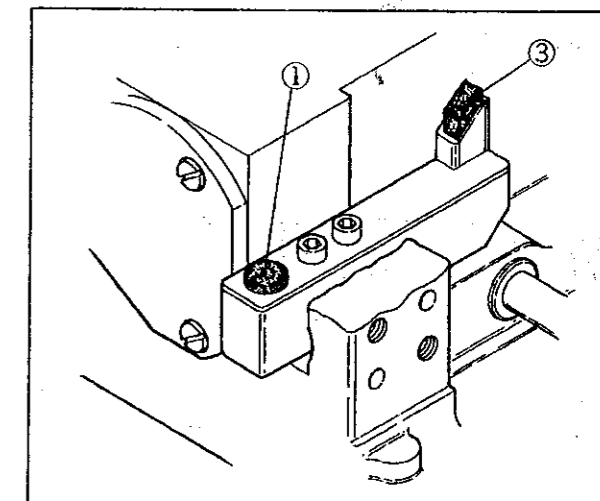

5. Adjusting Sewing Machine

⚠ WARNING

ALWAYS turn OFF the motor switch and check that the motor has already stopped before the work. Otherwise, you may be injured.

5-1 Needle thread tension

The standard distance between the left end of Needle Thread Take-up ① and the center of Screw ② (Left) is 52mm. The standard condition is that the top surface (a) of ① is level, when Needle Bar is at the top of its travel.

- (1) Loosen Screws ②.
- (2) To tighten needle thread, slide ① toward (T).
To loosen, slide ① toward (L).
- (3) Tighten Screws ②.

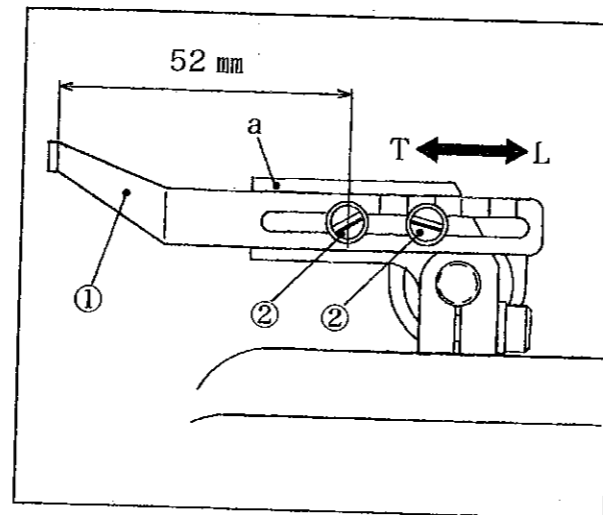

If this adjustment is not effective:

- (1) Loosen Screw ③.
- (2) To tighten, slide ④ toward (T). To loosen, slide ④ toward (L).
- (3) Tighten Screw ③.

Note: The standard distance is 8mm between the eye of ④ and the center of Screw ③.

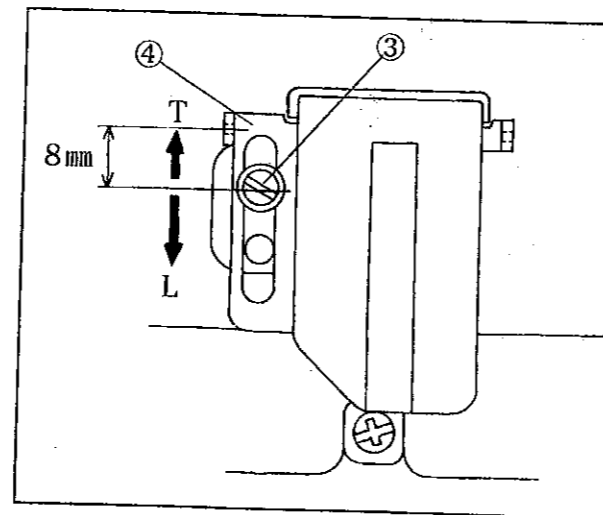

☆ When a loop of needle thread can not be formed by using stretchable thread like synthetic thread, Needle Thread Guide should be used.

- (1) Loosen Screw ⑦.
- (2) The standard condition is that the center of eye of Needle Bar Thread Eyelet ⑤ is the same height with the top surface of Needle Thread Guide ⑥ and ⑤ is parallel with ⑥, when Needle Bar is at the bottom.
- (3) Tighten Screw ⑦.

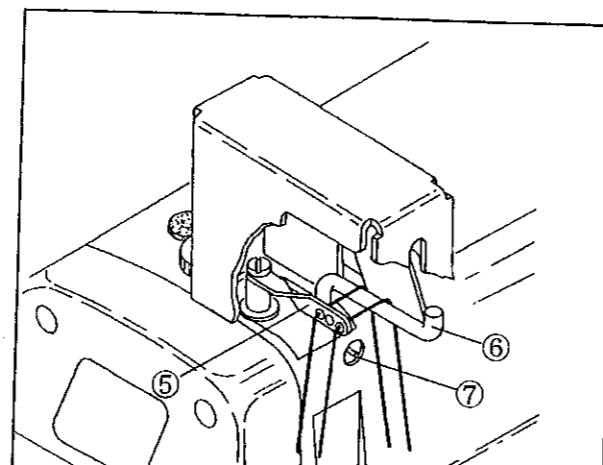

5.Adjusting Sewing Machine

5-2 Top cover thread tension

- (1) To decrease the feed of thread, raise Top Cover Thread Eyelet(Right) ① toward (T).
- (2) To increase, lower ① toward (L).

Notes

- (1) When using stretchable thread like woolly, loosen Screw ② to lower ① toward (L).
- (2) When using woolly thread, thread the lower eye.

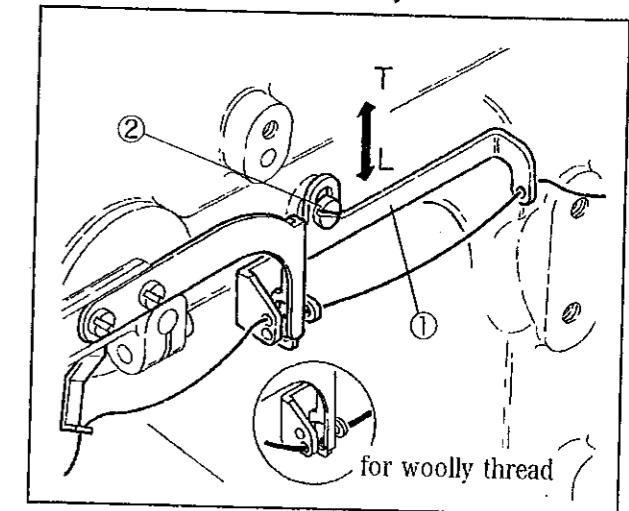

5-3 Looper thread tension

The figure shows Looper Thread Take-up area. The standard adjustment is that the holes of Eyelets ⑤ and ⑥ are aligned with the dot ④ on Cast-off Plate ③. To increase feed of thread, loosen Screws ⑧ of the Eyelets ⑤ and ⑥ and move the Eyelets toward operator. To decrease, move it away from operator.

Note: Take care not to increase feed of looper thread too much because it may cause skipping stitch.

When using woolly thread, move Eyelets ⑤ and ⑥ toward operator fully and do not pass the thread through Supplementary Tension Disc ⑦.

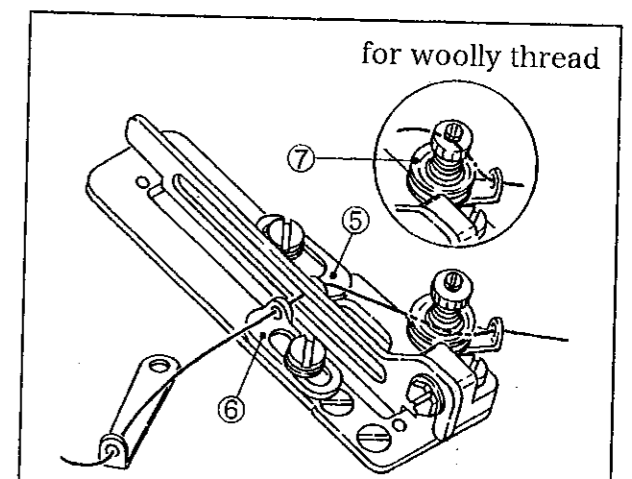
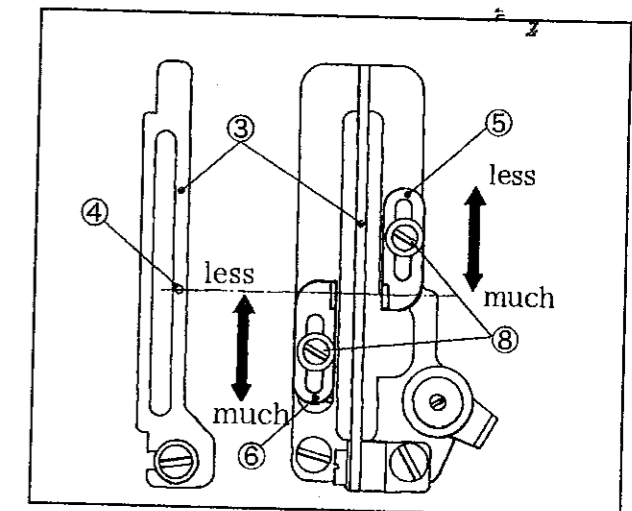

5-4 Position of Loper Thread Take-up

Looper Thread Take-up seen from Needle Bar side is shown below at left.

- (1) Loosen Screws②.
- (2) When the left Needle reaches at the half of Loper by lowering Needle Bar as shown at right, adjust so that thread is taken off at the highest point of Loper Thread Take-up①.
- (3) Tighten Screws②.

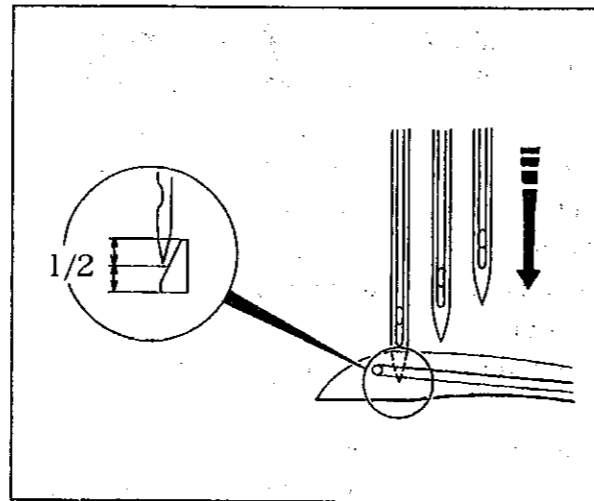
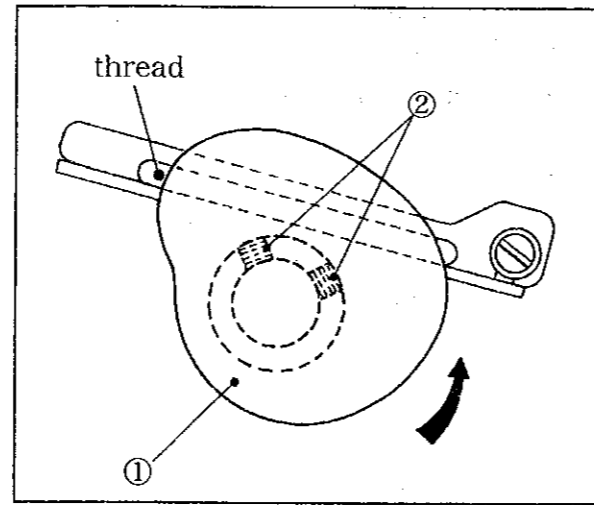

5-5 Removing Presser Foot and amount of Presser Foot

To remove:

- (1) Loosen Screw② of Lifter Lever Stop① and Screws ④ of Collar③.
- (2) Press down Lifter Lever⑤.

To adjust Presser Foot lift:

- (1) Press down ⑤ to make a space of 7.0 mm (for using Spreader⑦) between Stitch Plate and Presser Foot.
- (2) Tighten Screw②.
- (3) Make a space of 0.2 mm between Presser Bar Bushing⑥ and ③.
- (4) Tighten Screws④.

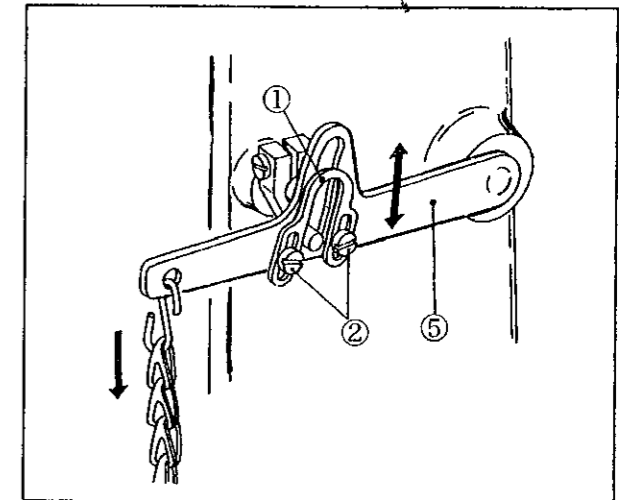

After above adjustment, press down Lifter Lever⑤ to the limit and check Presser Foot Height.

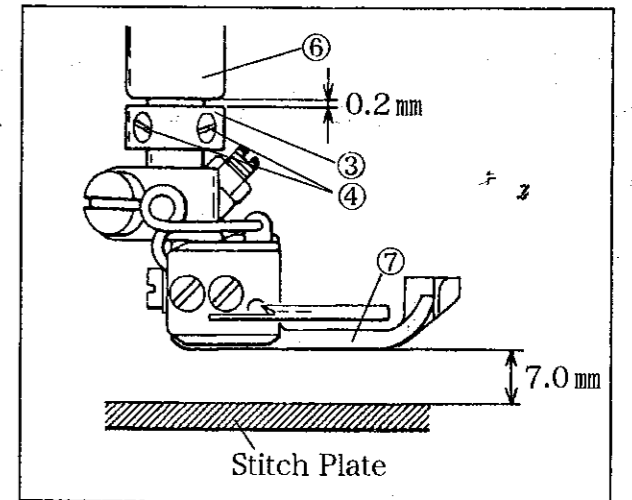

5-6 Relation between Needle and Stitch Plate

After adjusting the height of Needle Bar, Needles must be correctly aligned as shown by solid line. Take care not to be in the condition as shown by dotted line.

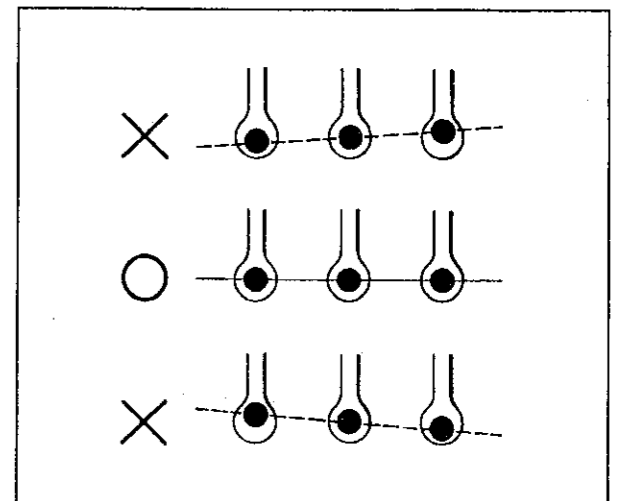

5-7 Fixing angle and height of Looper

- (1) Insert Looper① into Looper Holder ②fully.
 - (2) Tighten Screw③.
- The angle of 3° and the height are set accordingly.

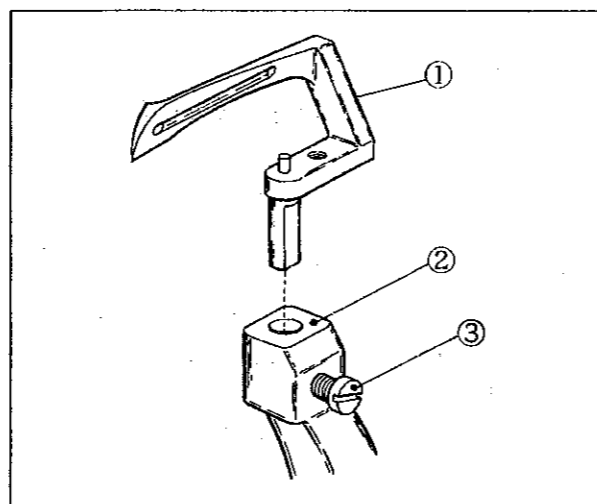

5-8 Movement of Looper to the right

When Needles are at the bottom of their travel and Looper is at the rightmost position, the distance (M) is made between the center line of the right Needle and the point of Looper. According to the needle distance, the distance(M) is different. See the following table.

- (1) To adjust, loosen Screw④ of Looper Holder.
- Note: Even when the needle distance is different, the distance between the center of Needle Bar and the point of Looper is 6mm.

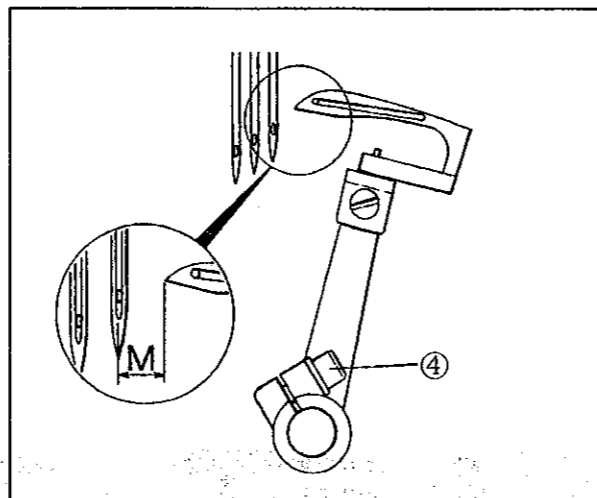

Needle Distance (Mark)	Movement of Looper to the right (M)
3.2mm (A)	4.4mm
4.0mm (B)	4.0mm
4.8mm (C)	3.6mm
5.6mm (D)	3.2mm
6.4mm (E)	2.8mm

☆ For easy adjustment of the distance(M), Timing Gauge should be used. Timing Gauge is an extra part. Please place an order with our agents or directly with us, if required.

5-9 Using Timing Gauge

Timing Gauge has the marks (A,B,C,D,E) for each needle distance.

- (1) Loosen Screw④ of Looper Holder.
- (2)When Looper is at the rightmost, fit the corresponding "V"groove of Timing Gauge into the right Needle and fit the point of Looper to Timing Gauge.
- (3) Tighten Screw④.

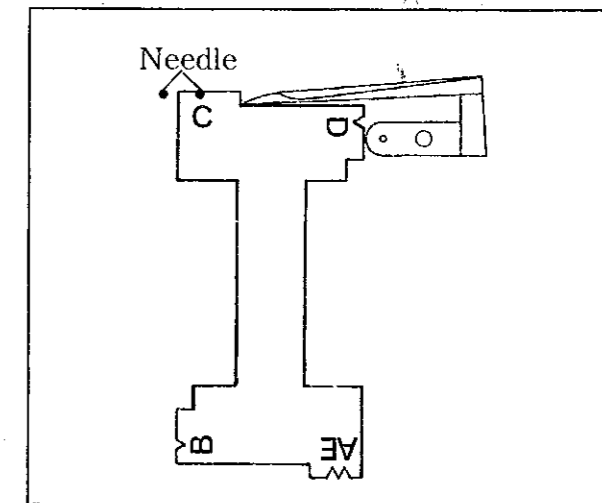

5-10 Height of Needle Bar

Notes:

- (1) Needle must be inserted into Needle Clamp fully to be screwed.
- (2) Looper must be inserted into Looper Holder fully to be screwed.

The height of Needle is fixed on the basis of Looper. When the point of Looper is at the center of the left Needle, the height of Looper must be 0.5 - 1.0 mm above the needle eye.

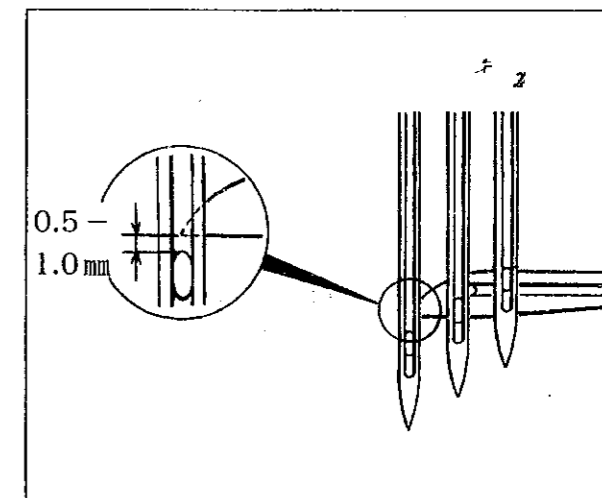

To adjust:

- (1) Insert a screwdriver into the hole① of Head Cover.
- (2) Loosen Screw② of Needle Bar Bracket.
- (3) Move Needle Bar up and down to adjust the height.
- (4) Tighten Screw②.

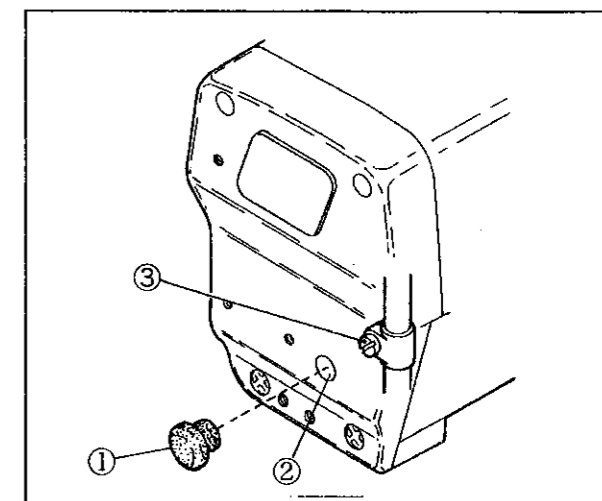

5-11 Longitudinal position of Needle and Loper

☆ for 3 Needles

- (1) Loosen Screw of Loper Holder.
 - (2) When the point① of Loper meets the left Needle ②, the clearance between them must be 0.1 – 0.2 mm.
 - (3) When the point① of Loper meets the center Needle③, a clearance between them must be 0 – 0.05 mm.
- When the point① of Loper meets the right Needle④, they contact slightly (about 0.2mm).
- (4) Make a clearance of 0 – 0.05mm between the point of Loper and Needle④ by pushing Needle Guard (Rear) against Needle④.

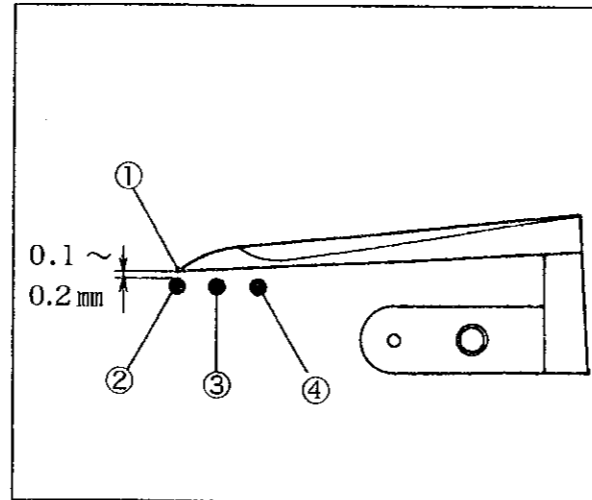

☆ for 2 Needles

- (1) Loosen Screw of Loper Holder.
- (2) When the point① of Loper meets the left Needle ⑤, the clearance between them must be 0.1 – 0.2 mm.
- (3) When the point① of Loper meets the right Needle ⑥, they contact slightly (about 0.2mm).
- (4) Make a clearance of 0 – 0.05mm between the point of Loper and Needle⑥ by pushing Needle Guard (Rear).

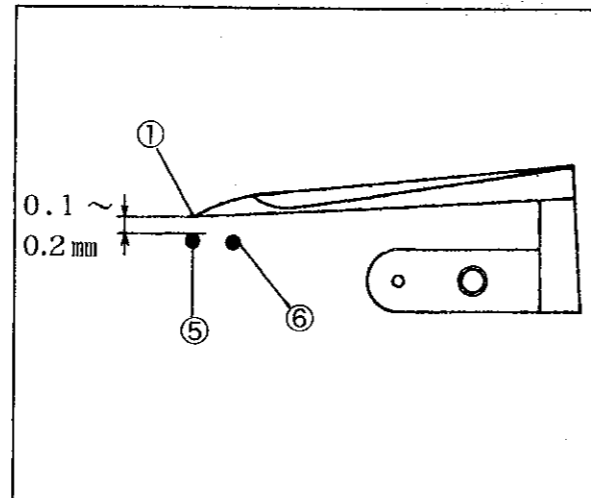

5-12 Needle and Needle Guard(Rear)

☆ The height of Needle Guard(Rear)

When the Needle is at its bottom position, align the line(a) on Needle Guard(Rear)① with the center of needle eye.

☆ Longitudinal position of Needle Guard (Rear)

- (1) Loosen Screws② and ③.
- (2) When the point of Loper comes to the center of the right Needle, make a clearance of 0 – 0.05 mm between Needle and Loper by pressing Needle Guard(Rear) on Needle.
- (3) Adjust a clearance of 0 – 0.05 mm between the left Needle and Needle Guard(Rear). (Refer to the clause 7-11).

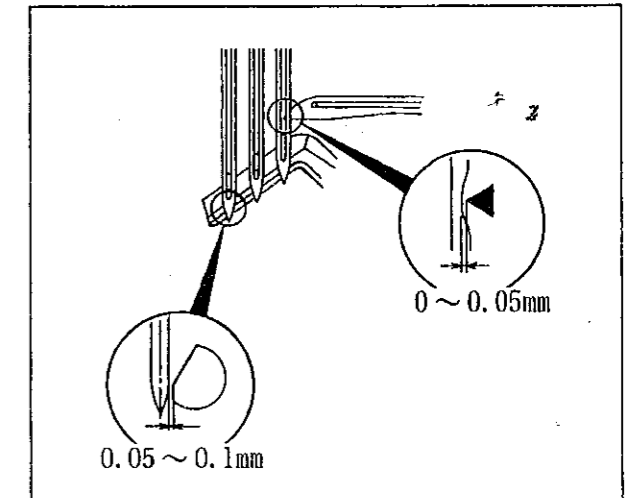
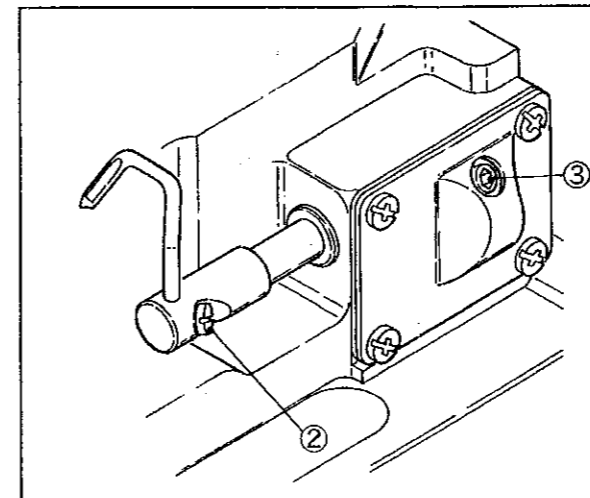
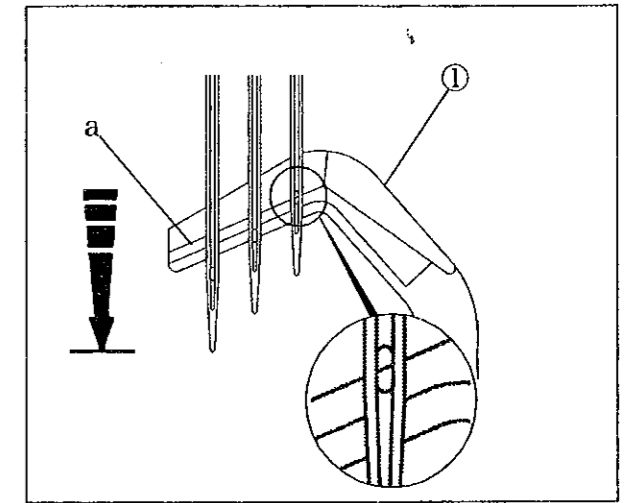

5-13 Needle and Needle Guard(Front)

When the point of Loper comes to the center of left and right Needles, loosen Screw⑤ and make the clearances of 0 – 0.3 mm between those Needles and Needle Guard(Front)④.

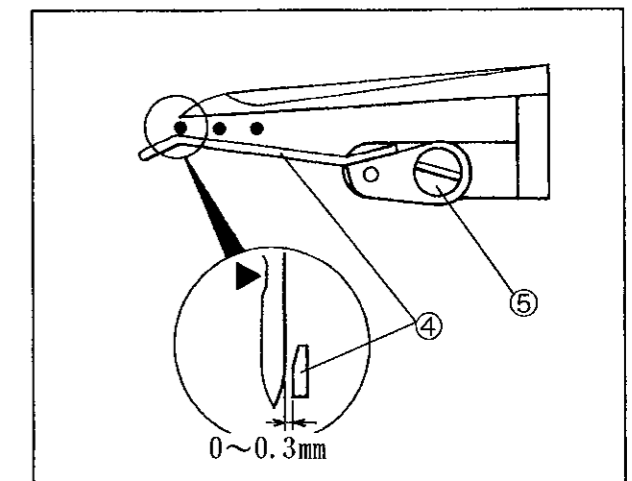

5-14 Height of Feed Dogs

When Feed Dogs are at the top position, the surface of Feed Dogs and the surface of Stitch Plate are parallel with each other.

- (1) Make Differential Feed Dog① and Main Feed Dog② to be at the same height.
- (2) Make a distance of 1.0 - 1.2mm from the surface of Stitch Plate to the surface of Feed Dogs.

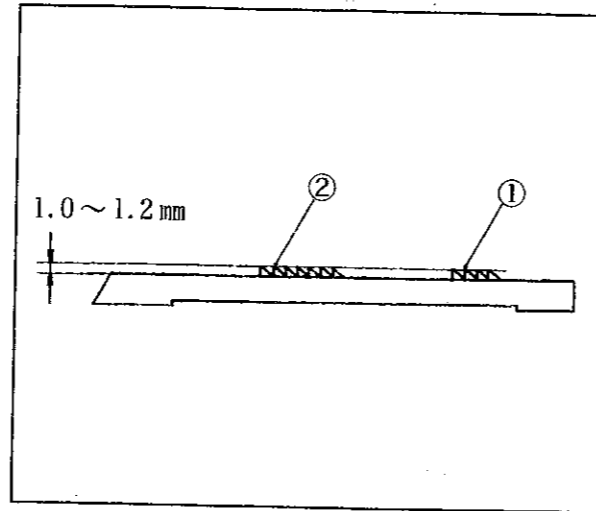

5-15 Needle and Spreader

5-15-1 Installing Spreader

- To make a space of 0.5 - 0.8 mm between the left Needle and the hook(a) of Spreader①, loosen Screw② and adjust.

To make a distance of 9 - 11 mm from Stitch Plate to Spreader①, loosen Screw② and adjust.

- To make a distance of 4.5 - 5.5 mm from the hook(a) to the center line of the left Needle, when reaching Spreader① to its leftmost loosen Screw③ and adjust.

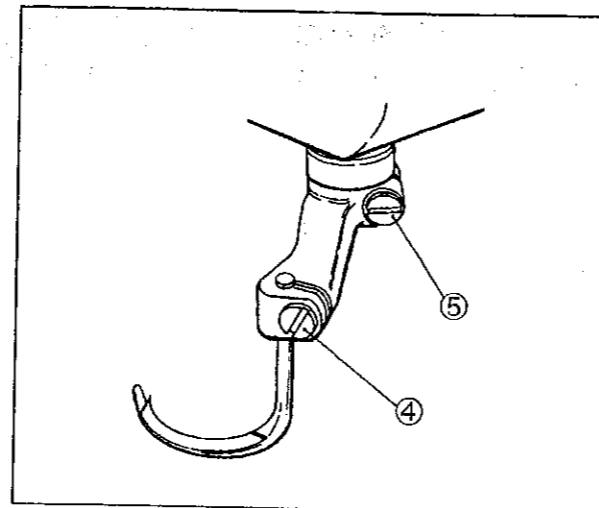
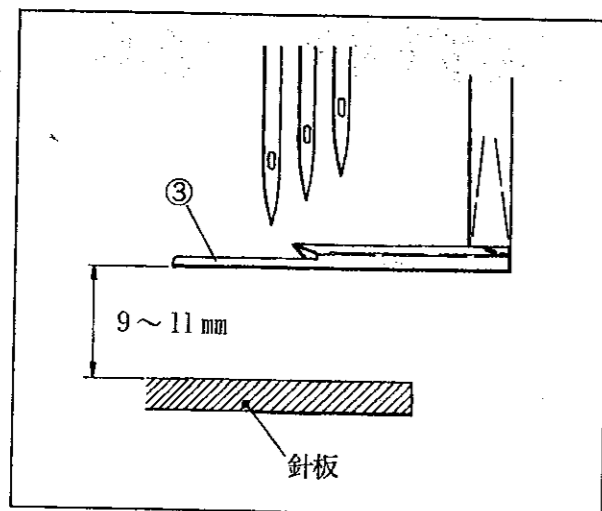
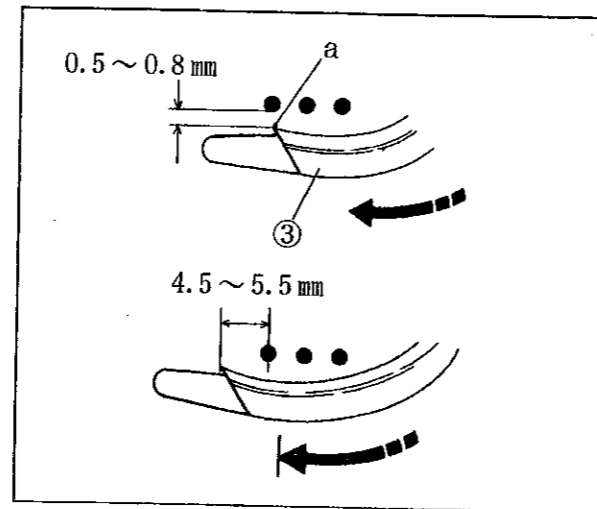

5-15-2 Installing Top Cover Thread Guide

- (1) Loosen Screws⑥ to make a space of 0.5mm between Top Cover Thread Guide⑤ and Spreader③.
- (2) When reaching Spreader③ to the rightmost (at the position that thread can be hooked smoothly), tighten Screws⑥.

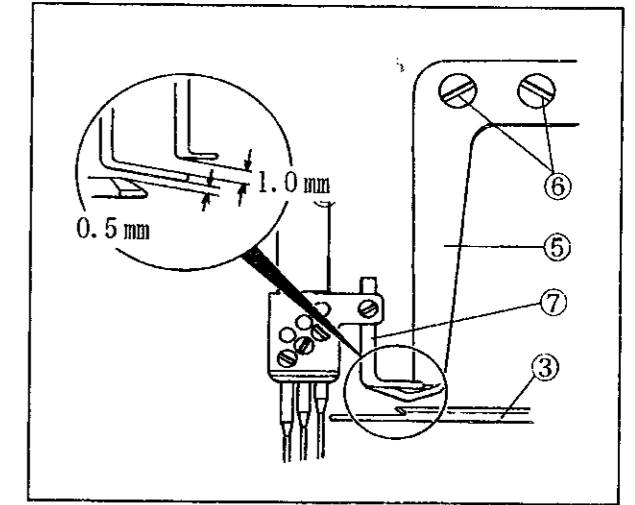

5-15-3 Installing Top Cover Thread Eyelet

- (1) Loosen Screw⑧.
- (2) When Needle Bar is at the bottom of its travel, make a space of 1.0mm between Top Cover Thread Guide⑤ and Top Cover Thread Eyelet⑦.
- (3) Position the eye of Top Cover Thread Eyelet⑦ on the prolongation of slot of Top Cover Thread Guide⑤.
- (4) Tighten Screw⑧.

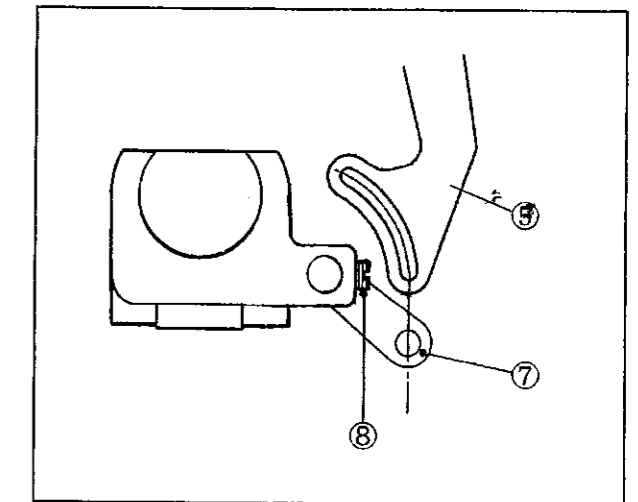

※ Adjust above Spreader, Top Cover thread Guide, and Top Cover Thread Eyelet properly depending on the thread.

6. Specifications

Dimensions	500 (L) ×250 (W) ×430 (H) mm
Weight	41kg
Stitch Type	I S O 406,407,602,605
Applications	Covering seam of knitted wear, etc.
Sewing Speed	Up to 6000rpm (during intermittent operation)
Stitch Length	1.4~3.6mm number of stitch : 7 - 18 stitch/inch 8 - 21 stitch/30mm
Needle System	Schmetz or Organ UY128GAS #65 - #90
Needle Distance	2 needles : 3.2, 4.0, 4.8mm
	3 needles : 4.8, 5.6, 6.4mm
Needle Stroke	31mm
Presser Foot Lift	7.0mm (with Top Cover Thread Mechanism)
Feed Regulation	By Pushbutton
Differential Ratio	Max. normal differential ratio : 1 : 2 Max. reverse differential ratio : 1 : 0.7
Differential Feed Regulation	Adjustment during operation is possible by moving Lever up and down from the outside.
Lubrication	Automatic Lubrication by Oil Pump
Lubricating Oil	YAMATO SF OIL NO. 28
Capacity of Oil Reservoir	1100cc
Installation	Semi-submerged type